

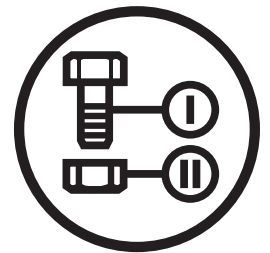

Parts Manual

M-ZT 52

Zero Turn Mower / 967177006-01



Please read the operator manual carefully and make sure you understand the instructions before using the machine.

When you need spare parts or support in service questions, warranty issues, etc., please consult the following professional:

This manual belongs to the machine with the manufacturing number:	Engine	Transmission

Manufacturing Number

The machine's manufacturing number can be found on the printed plate affixed to the engine compartment.

Stated on the plate, from the top are:

- The machine's type designation (I.D.).
- The manufacturer's type number (Model).
- The machine's serial number (Serial no.)

Please have the type designation and serial number available when ordering spare parts.

The engine's manufacturing number is stamped on one of the valve covers.

The plate states:

- The engine's model.
- The engine's type.
- Code

Please have these available when ordering spare parts.

The wheel motors and hydrostatic pumps have a barcode decal affixed at the rear.

Accessories Available

Collection System.....	966 79 30-02
Mulch Kit.....	965 89 40-02

CONTENTS

FRAME.....	4
ENGINE PLATE.....	6
STEERING	8
IGNITION.....	10
PARKING BRAKE	12
HYDRAULIC PUMP-MOTOR	14
WHEELS	16
MOWER LIFT / DECK LIFT	18
MOWER DECK / CUTTING DECK.....	20
SEAT	22
DECALS.....	24
PROTECTION FRAME	26
ACCESSORIES	
BLOWER ASSEMBLY.....	28
CHUTES	30
BAGGER.....	32
MOUNT, GUARD, BELT	34
MULCH KIT	36

Illustrations may or may not represent the actual assemblies and it is not recommended to use this manual as a guide to assemble or disassemble the mower.

NOTE: All fasteners are Grade 5 unless otherwise specified.

FRAME

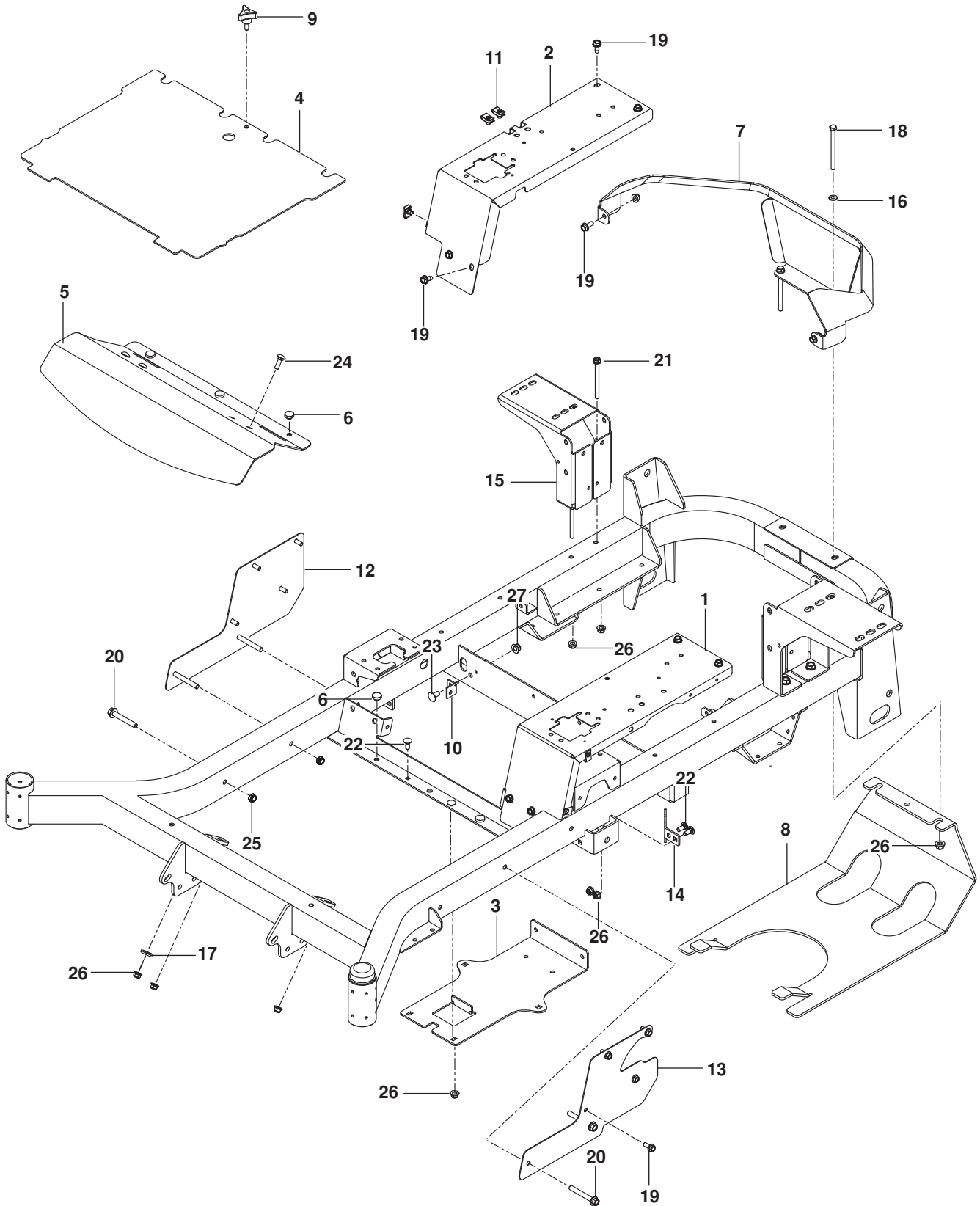

FRAME

ITEM	PART NO.	QTY.	DESCRIPTION	ITEM	PART NO.	QTY.	DESCRIPTION
1..	577 25 68-02.....	1	PANEL, FILLER LT ORG	15..	575 53 36-02.....	2	MOUNT, TANK BLK
2..	577 25 69-02.....	1	PANEL, FILLER RT ORG	16..	819 11 11-16.....	2	WASHER ⁵ / ₁₆ SAE FLT
3..	575 01 72-02.....	1	PLATE, BATTERY ORG	17..	539 10 95-54.....	1	WASHER 1/2 FLT
4..	539 13 27-44.....	1	PLATE w/ SAFTY DECAL ORG	18..	539 10 23-35.....	2	BOLT ⁵ / ₁₆ -18 x 4 HEX HD
5..	539 13 23-80.....	1	PLATE, FOOTREST ORG	19..	525 46 47-01.....	16	BOLT ⁵ / ₁₆ -18 x 3/4 HEX FLG HD
6..	539 10 25-87.....	7	GROMMET, BUMPER	20..	539 13 17-81.....	5	BOLT ³ / ₈ -16 x 2 3/4 HEX FLG HD
7..	575 34 84-02.....	1	GUARD, REAR	21..	874 49 05-60.....	4	BOLT ⁵ / ₁₆ -18 x 3 3/4 HEX FLG HD
8..	521 92 18-05.....	1	GUARD, SKID	22..	539 99 03-16.....	6	BOLT ⁵ / ₁₆ -18 x 3/4 RD HD SQNK
9..	539 10 44-11.....	1	KNOB w/ STUD	23..	872 05 06-06.....	2	BOLT ³ / ₈ -16 x 3/4 RD HD SQNK
10..	575 24 52-02.....	2	BRACKET, DAMPENER BLK	24..	539 99 02-08.....	3	BOLT ⁵ / ₁₆ -18 x 1 RD HD SQNK
11..	539 10 47-63.....	8	RETAINER-U TYPE	25..	539 20 02-82.....	5	NUT ³ / ₈ -16 HEX JAM NYLOC
12..	577 25 98-01.....	1	SIDE, LT BLK	26..	539 11 28-99.....	17	NUT ⁵ / ₁₆ -18 HEX FLG NYLOC
13..	577 25 97-01.....	1	SIDE, RT BLK	27..	521 99 65-01.....	2	NUT ³ / ₈ -16 HEX FLG NYLOC
14..	505 25 64-01.....	2	STOP, DECK				

ENGINE PLATE

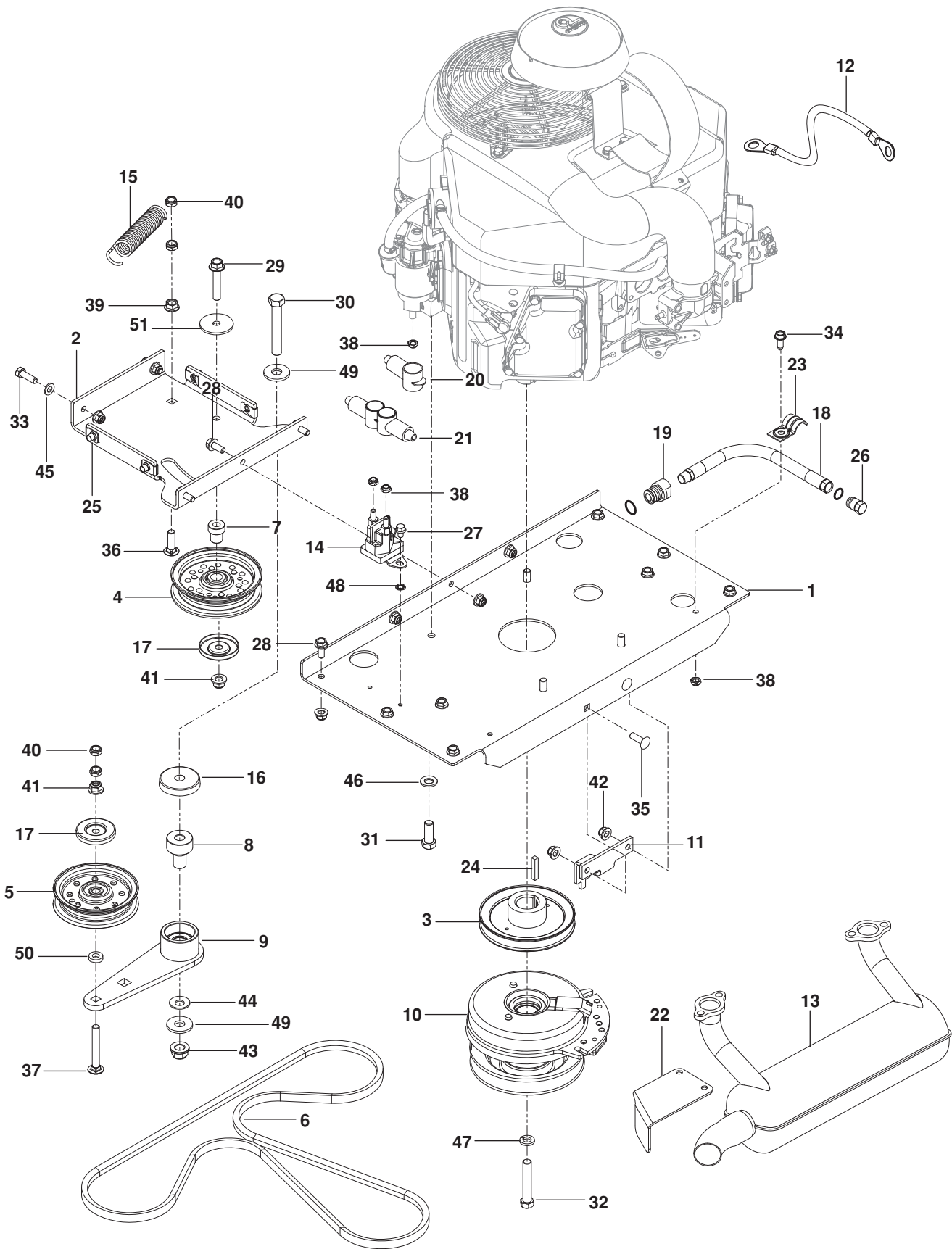

ENGINE PLATE

ITEM	PART NO.	QTY.	DESCRIPTION	ITEM	PART NO.	QTY.	DESCRIPTION
1..	574 84 63-02.....	1	PLATE, ENGINE BLK	28..	874 49 05-12.....	11	BOLT $\frac{5}{16}$ -18 x $\frac{3}{4}$ HEX FLG HD
2..	574 84 64-02.....	1	PLATE, IDLER BLK	29..	874 49 06-32.....	1	BOLT $\frac{3}{8}$ -16 x 2 HEX FLG HD
3..	574 81 10-01.....	1	PULLEY, V $1\frac{1}{8}$ BORE	30..	874 78 08-52.....	1	BOLT $\frac{1}{2}$ -13 x $3\frac{1}{4}$
4..	539 97 66-88.....	1	PULLEY, IDLER	31..	874 78 06-16.....	4	BOLT $\frac{3}{8}$ -16 x 1
5..	532 17 58-20.....	1	PULLEY, IDLER SECONDARY	32..	581 33 28-02.....	1	BOLT $\frac{7}{16}$ -20 x $2\frac{1}{2}$
6..	574 87 09-01.....	1	BELT	33..	874 78 05-16.....	2	BOLT $\frac{5}{16}$ -18 x 1
7..	525 43 56-01.....	1	PIVOT, IDLER	34..	874 78 04-08.....	1	BOLT $\frac{1}{4}$ -20 x $\frac{1}{2}$
8..	510 20 63-01.....	1	PIVOT, BEARING	35..	872 11 05-08.....	2	BOLT $\frac{5}{16}$ -18 x 1 RD HD SQNK
9..	510 04 16-03.....	1	ARM, IDLER w/ BEARINGS	36..	872 14 06-10.....	1	BOLT $\frac{3}{8}$ -16 x $1\frac{1}{4}$ RD HD SQNK
10..	574 60 70-01.....	1	CLUTCH, 200 FT-LB	37..	872 14 06-22.....	1	BOLT $\frac{3}{8}$ -16 x $2\frac{3}{4}$ RD HD SQNK
11..	575 01 73-02.....	1	STOP, CLUTCH	38..	539 10 81-20.....	4	NUT $\frac{1}{4}$ -20 HEX THIN
12..	539 10 27-57.....	1	CABLE, POSITIVE	39..	873 40 06-00.....	1	NUT $\frac{3}{8}$ -16 HEX WHIZLK
13..	525 75 02-01.....	1	MUFFLER	40..	539 20 02-82.....	4	NUT $\frac{3}{8}$ -16 HEX JAM NYLOC
14..	532 19 25-07.....	1	SOLENOID	41..	521 99 65-01.....	2	NUT $\frac{3}{8}$ -16 HEX FLG NYLOC
15..	510 25 44-01.....	1	SPRING, PUMP	42..	539 11 28-99.....	15	NUT $\frac{5}{16}$ -18 HEX FLG NYLOC
16..	539 11 46-62.....	1	SHIELD, DUST	43..	521 99 11-01.....	1	NUT $\frac{1}{2}$ -13 HEX FLG NYLOC
17..	510 25 45-01.....	2	SHIELD, DUST	44..	539 11 55-28.....	1	WASHER $\frac{1}{2}$ " BELLEVILLE
18..	584 82 55-01.....	1	HOSE, DRAIN	45..	819 11 11-16.....	2	WASHER $\frac{5}{16}$ SAE FLAT
19..	539 11 96-80.....	1	ADAPTER, OIL DRAIN	46..	810 03 06-00.....	4	WASHER $\frac{3}{8}$ SPLT LK
20..	539 10 27-59.....	1	INSULATOR	47..	810 03 07-00.....	1	WASHER $\frac{7}{16}$ SLW
21..	539 13 15-63.....	2	INSULATOR	48..	539 99 00-53.....	1	WASHER $\frac{1}{4}$ INT TOOTH LK
22..	579 15 09-01.....	1	SHIELD, MUFFLER	49..	819 18 22-12.....	2	WASHER $\frac{1}{2}$ FLT
23..	539 10 13-63.....	1	CLAMP	50..	539 10 95-62.....	1	WASHER $\frac{3}{8}$ x $\frac{3}{4}$
24..	539 91 27-57.....	1	KEY $\frac{1}{4}$ SQ x $1\frac{1}{4}$	51..	539 11 18-97.....	1	WASHER, SPECIAL
25..	539 10 47-63.....	4	RETAINER, U TYPE	NOT SHOWN			
26..	585 80 71-01.....	1	PLUG, HOSE	522 59 86-01.....	1	KAWASAKI PIGTAIL	
27..	817 49 04-06.....	1	SCREW $\frac{1}{4}$ -20 x $\frac{3}{8}$ THD FRM	586 83 97-01.....	2	GASKET, EXHAUST	

STEERING

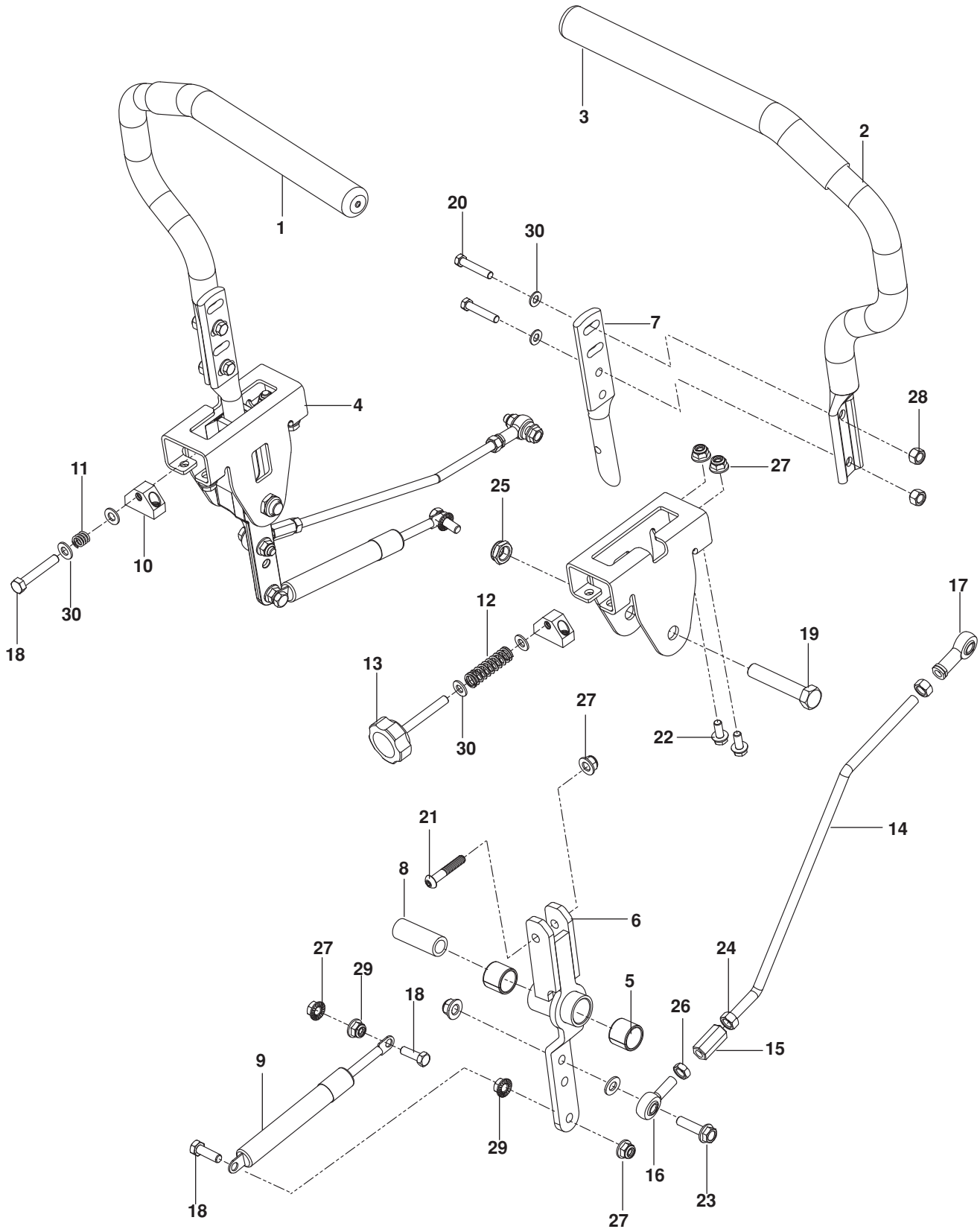

STEERING

ITEM	PART NO.	QTY.	DESCRIPTION	ITEM	PART NO.	QTY.	DESCRIPTION
1..	539 13 20-09.....	1	LEVER w/ GRIP RT	16..	539 11 66-90.....	2	ROD END LT
2..	539 13 20-10.....	1	LEVER w/ GRIP LT	17..	539 11 57-29.....	2	ROD END RT
3..	539 13 08-94.....	2	GRIP, FOAM	18..	874 78 05-20.....	5	BOLT $\frac{5}{16}$ -18 x 1 $\frac{1}{4}$ HEX HD
4..	586 73 72-02.....	2	BRACKET, CONTROL	19..	874 78 08-44.....	2	BOLT $\frac{1}{2}$ -13 x 2 $\frac{3}{4}$ HEX HD
5..	532 43 82-82.....	4	BEARING, FLG	20..	539 97 69-35.....	4	BOLT $\frac{5}{16}$ -18 x 1 $\frac{1}{2}$ HEX HD
6..	587 18 77-01.....	2	LEVER, CONTROL	21..	576 85 04-02.....	2	SCREW $\frac{5}{16}$ -18 X 1 $\frac{3}{4}$ BTN HD
7..	577 42 00-01.....	2	LEVER, HANDLE	22..	525 46 47-01.....	8	BOLT $\frac{5}{16}$ -18 X $\frac{3}{4}$ HEX FLG HD
8..	584 92 72-01.....	2	SPACER, PIVOT CONTROL	23..	525 54 40-01.....	4	BOLT $\frac{5}{16}$ -18 x 1 $\frac{1}{4}$ HEX FLG HD
9..	539 10 27-20.....	2	DAMPENER	24..	539 99 02-23.....	4	NUT $\frac{5}{16}$ -24 HEX
10..	581 43 75-01	2	BLOCK, TRACKING	25..	539 10 80-10.....	2	NUT $\frac{1}{2}$ -13 HEX JAM NYL GR2
11..	539 10 28-45.....	1	SPRING	26..	539 99 10-73.....	2	NUT $\frac{5}{16}$ -24 HEX JAM LH
12..	576 85 03-01.....	1	SPRING	27..	539 11 28-99.....	10	NUT $\frac{5}{16}$ -18 HEX FLG NYLOC
13..	539 13 17-99.....	1	KNOB	28..	539 99 07-17.....	6	NUT $\frac{5}{16}$ -18 HEX NYLOC
14..	574 81 14-01.....	2	ROD, MOTION CONTROL	29..	539 99 05-85.....	4	NUT $\frac{5}{16}$ -18 HEX WHIZLK
15..	539 11 66-89.....	2	COUPLER, ROD END	30..	819 11 11-16.....	12	WASHER $\frac{5}{16}$ SAE FLT

IGNITION

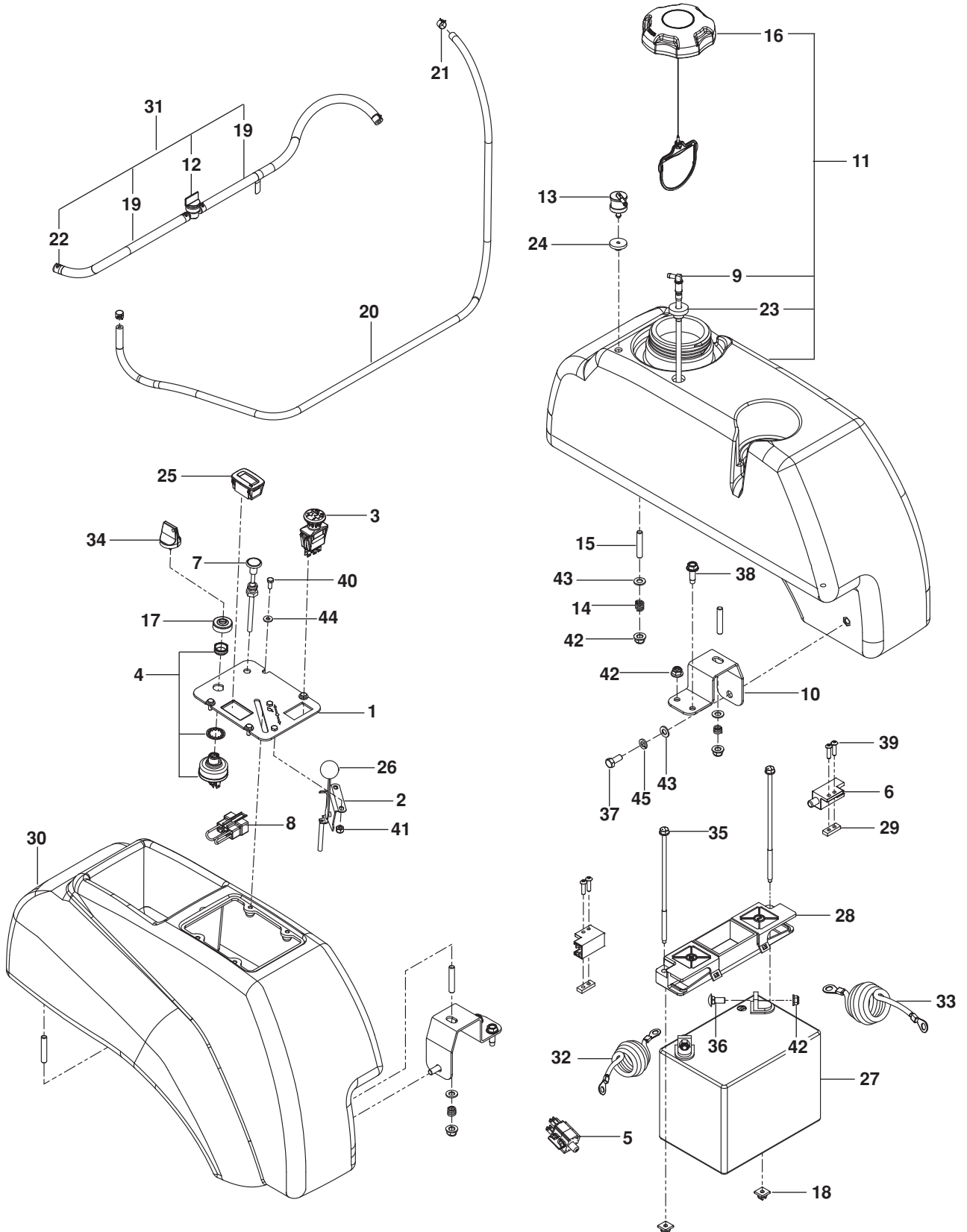

IGNITION

ITEM	PART NO.	QTY.	DESCRIPTION	ITEM	PART NO.	QTY.	DESCRIPTION
1..	574 84 12-04.....	1	PLATE, CONSOLE, BLK	25..	586 16 18-01.....	1	MINDER, SERVICE
2..	539 11 24-38.....	1	CABLE, THROTTLE	26..	539 13 30-49.....	1	KNOB
3..	539 13 16-27.....	1	SWITCH, PTO 10 AMP	27..	539 10 24-36.....	1	BATTERY
4..	574 45 54-01.....	1	SWITCH, IGNITION	28..	539 10 76-28.....	1	BATTERY HOLD DOWN
5..	539 11 37-92.....	1	SWITCH, BRAKE	29..	539 10 26-78.....	2	PLATE, TAPPED
6..	532 10 95-53.....	2	SWITCH, INTERLOCK	30..	539 10 75-93.....	1	CONSOLE, RT GRY
7..	574 20 69-03.....	1	CHOKE CONTROL	31..	576 54 78-02.....	1	ASSY, FUEL LINE
8..	575 32 10-01.....	1	PLUG, TIMER	32..	539 10 49-74.....	1	CABLE, POSITIVE 31"
9..	576 46 92-01.....	1	FITTING, FUEL	33..	539 10 76-45.....	1	CABLE, NEGATIVE 32"
10..	539 13 16-71.....	2	SUPPORT, TANK, BLK	34..	574 45 55-01.....	1	KEY, IGNITION
11..	578 36 81-02.....	1	TANK ASSY LT GRY	35..	539 10 76-32.....	2	BOLT 1/4 x 7 1/2
12..	539 91 63-25.....	1	VALVE, FUEL	36..	539 99 03-16.....	2	BOLT 5/16-18 x 3/4 RD HD SQNK
13..	576 61 81-01.....	1	VALVE, FUEL CHECK	37..	874 78 05-12.....	2	BOLT 5/16-18 x 3/4 HEX HD
14..	539 10 28-45.....	6	SPRING	38..	817 49 05-16.....	3	SCREW 5/16-18 x 1 THD FRM
15..	539 10 25-02.....	6	STUD 5/16-18	39..	574 82 27-01.....	4	SCREW #10-24 x 3/4 SKT HD
16..	575 01 81-01.....	1	FUEL CAP w /TETHER	40..	539 99 04-11.....	6	SCREW #10-24 x 1/2 SLT
17..	539 10 31-78.....	1	CAP, IGNITION SWITCH NUT	41..	574 82 27-01.....	4	SCREW #10-24 x 3/4 SKT HD
18..	539 10 76-29.....	2	PUSHNUT 1/4 NYLON	42..	539 11 28-99.....	12	NUT 5/16-18 HEX FLG NYLOC
19..	539 93 29-56.....	2	HOSE, FUEL 10"	43..	819 11 11-16.....	8	WASHER 5/16 SAE FLT
20..	576 66 06-11.....	1	HOSE 3/16 VAPOR 36"	44..	819 07 08-18.....	4	WASHER #10
21..	575 43 65-01.....	2	CLAMP, HOSE	45..	810 03 05-00.....	2	WASHER 5/16 SLW
22..	539 91 22-22.....	4	CLAMP, HOSE				NOT SHOWN
23..	539 10 52-45.....	1	GROMMET, RUBBER		585 99 97-01.....	1	HARNESS, MAIN
24..	584 64 82-01.....	1	GROMMET, CHECK VALVE				

PARKING BRAKE

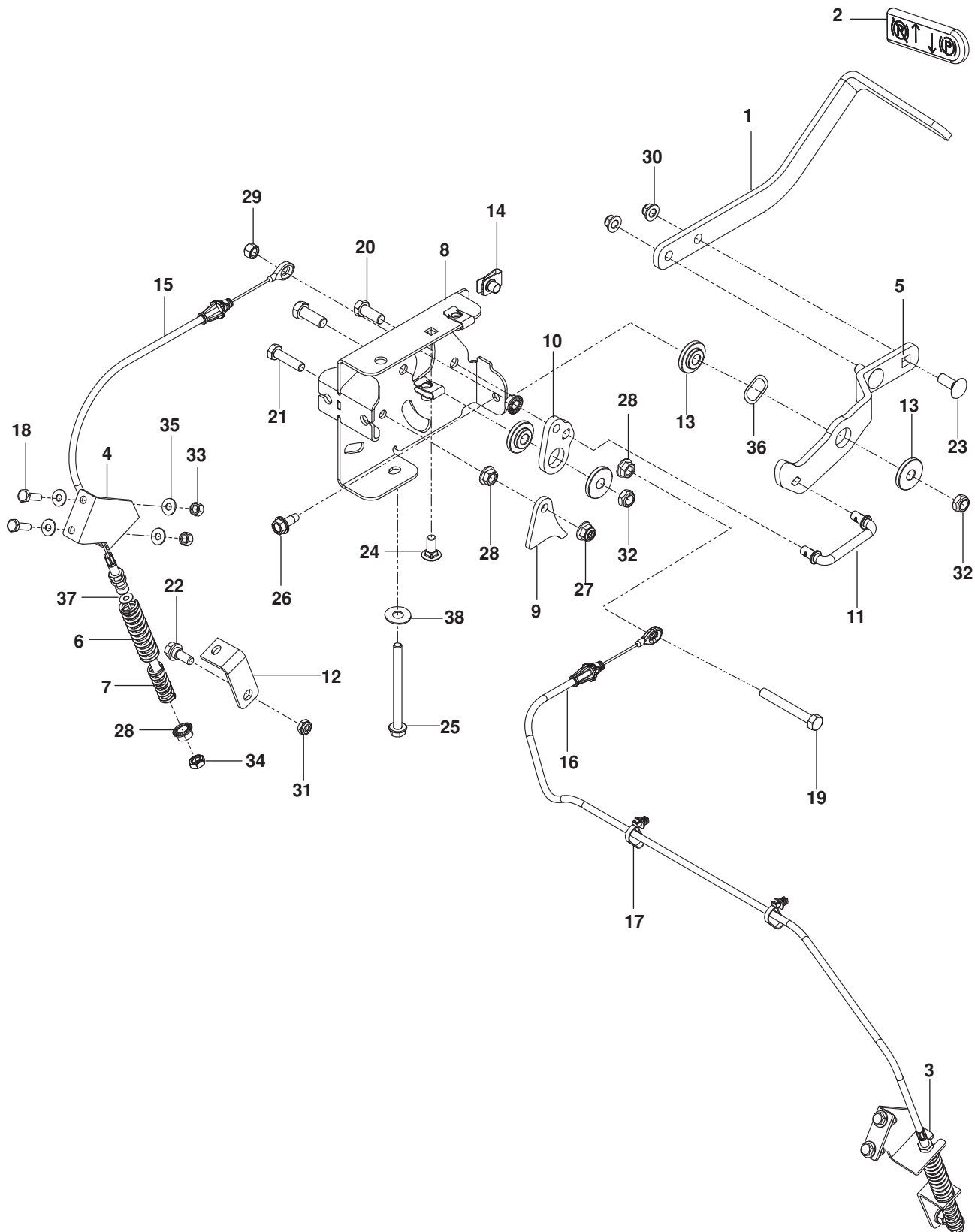

PARKING BRAKE

ITEM	PART NO.	QTY.	DESCRIPTION	ITEM	PART NO.	QTY.	DESCRIPTION
1..	539 13 21-51.....	1	ARM, BRAKE	20..	539 99 05-63.....	2	BOLT 3/8-16 x 1 HEX HD
2..	539 10 50-36.....	1	GRIP, BRAKE HANDLE	21..	539 99 02-09.....	1	BOLT 5/16-18 x 1 HEX HD
3..	575 22 96-02.....	1	BRACKET, RT BLK	22..	539 11 03-03.....	2	BOLT 5/16 SHOULDER
4..	575 22 97-02.....	1	BRACKET, LT BLK	23..	539 99 06-45.....	2	BOLT 3/8-16 x 1 RD HD SQNK
5..	539 13 24-23.....	1	LEVER, BRAKE	24..	539 99 03-16.....	1	BOLT 5/16-18 x 3/4
6..	575 23 02-01.....	2	SPRING, RETURN	25..	539 13 17-80.....	1	BOLT 5/16-18 x 3 3/4 HEX FLG HD
7..	575 23 03-01.....	2	SPRING, ENGAGEMENT	26..	539 10 74-75.....	1	BOLT 5/16-18 x 3/4 THD FRM
8..	539 13 21-58.....	1	MOUNT, BRAKE	27..	539 11 28-99.....	4	NUT 5/16-18 HEX FLG NYLOC
9..	539 13 21-54.....	1	ACTUATOR, SWITCH	28..	539 99 05-85.....	5	NUT 5/16-18 HEX WHIZLK
10..	539 13 21-53.....	1	BELLCRANK, BRAKE	29..	539 99 07-17.....	1	NUT 5/16-18 HEX NYLOC
11..	539 13 24-24.....	1	LINKAGE, BRAKE	30..	521 99 65-01.....	2	NUT 3/8-16 HEX FLG NYLOC
12..	575 22 98-02.....	2	BRACKET, BRAKE	31..	539 11 56-17.....	2	NUT 5/16 HEX NYLOC
13..	539 13 21-61.....	4	BUSHING, BRAKE	32..	539 20 02-82.....	2	NUT 3/8-16 HEX JAM NYLOC
14..	539 10 47-63.....	3	RETAINER, U TYPE 5/16-18	33..	539 97 69-78.....	4	NUT 1/4-20 HEX NYLOC
15..	539 13 21-73.....	1	CABLE, BRAKE SHORT	34..	539 10 78-97.....	2	NUT 5/16-18 HEX JAM
16..	539 13 21-74.....	2	CABLE, BRAKE LONG	35..	539 99 00-55.....	8	WASHER 1/4 SAE FLT
17..	505 28 00-01.....	2	TIE WRAP w/ CLIP	36..	539 13 30-07.....	1	WASHER .825 WAVE
18..	539 99 06-43.....	4	BOLT 1/4-20 x 7/8 HEX HD	37..	539 99 01-22.....	2	WASHER 3/8 SAE
19..	539 10 83-96.....	1	BOLT 5/16-18 x 2 1/2 TPBLT HX HD	38..	539 10 95-54.....	1	WASHER 1/2 FLT

HYDRAULIC PUMP-MOTOR

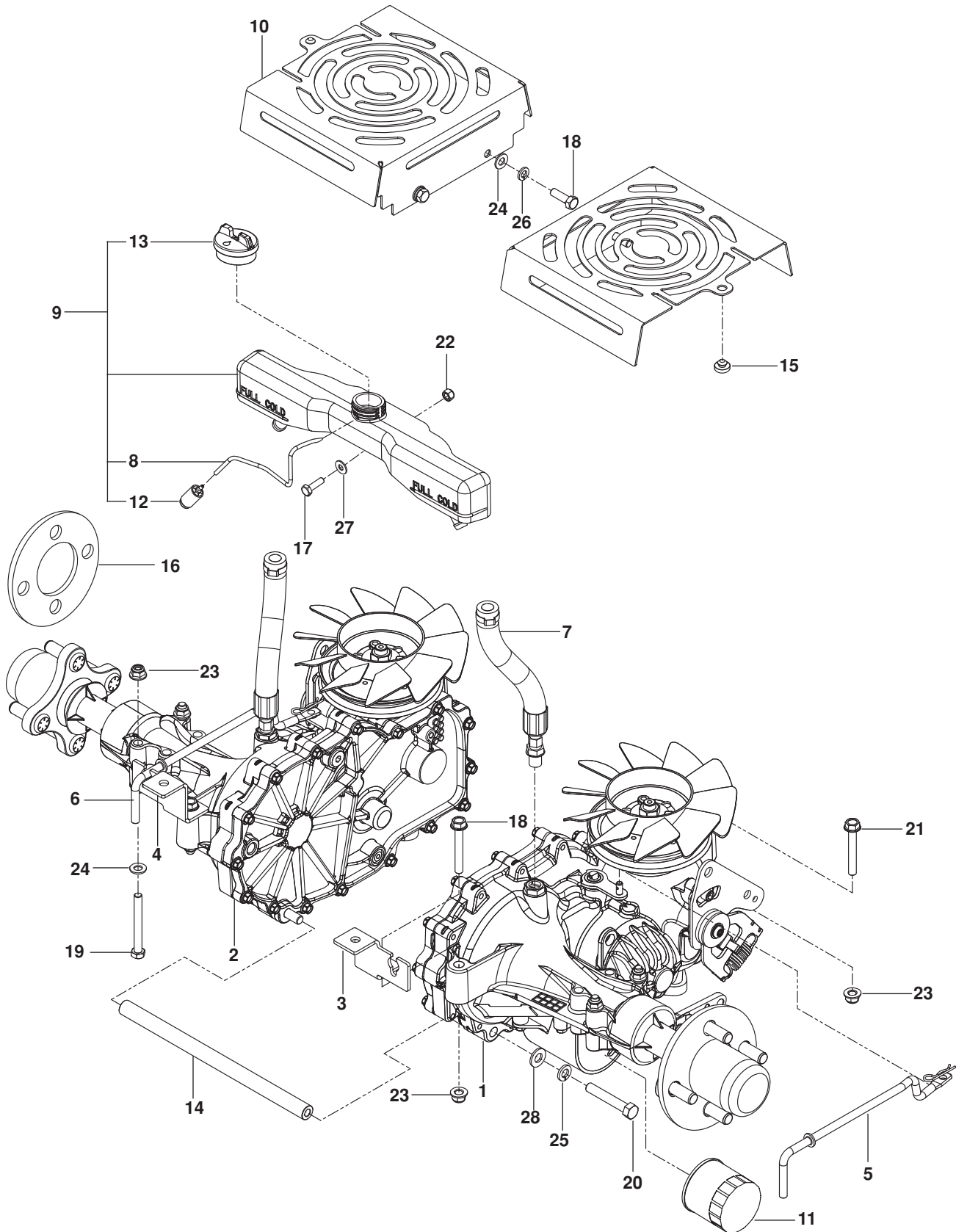

HYDRAULIC PUMP-MOTOR

ITEM	PART NO.	QTY.	DESCRIPTION	ITEM	PART NO.	QTY.	DESCRIPTION
1..	574 56 91-01.....	1	TRANS, ZT-3400, LT	15..	539 10 25-87.....	2	GROMMET, BUMPER
2..	574 56 91-02.....	1	TRANS, ZT-3400, RT	16..	580 90 62-01.....	2	SPACER, WHEEL
3..	575 01 71-02.....	1	BRACKET, TRANS, LT	17..	539 99 06-43.....	1	BOLT 1/4-20 x 7/8 HEX HD
4..	575 01 70-02.....	1	BRACKET, TRANS, RT	18..	539 99 02-09.....	4	BOLT 5/16-18 x 1 HEX HD
5..	539 13 16-16.....	1	LINKAGE, BYPASS LT	19..	539 10 17-21.....	4	BOLT 5/16-18 x 2 3/4 HEX HD
6..	539 13 16-18.....	1	LINKAGE, BYPASS RT	20..	539 10 85-51.....	2	BOLT 3/8-16 x 2 1/2 HEX HD GR8
7..	574 89 21-01.....	2	HOSE, EXPANSION	21..	574 23 38-01.....	4	BOLT 5/16-18 x 2 1/4 HEX FLG HD
8..	586 06 75-01.....	1	HOSE, FUEL	22..	539 97 69-78.....	1	NUT 1/4-20 HEX NYLOC
9..	585 31 82-01.....	1	TANK, EXPANSION	23..	539 11 28-99.....	8	NUT 5/16-18 HEX FLG NYLOC
10..	575 77 82-02.....	2	COVER, FAN	24..	819 11 11-16.....	8	WASHER 5/16 SAE FLT
11..	539 11 34-66.....	2	FILTER, HYDRO	25..	539 99 01-18.....	2	WASHER 3/8 SPLT LK
12..	530 09 56-46.....	1	FILTER	26..	810 03 05-00.....	4	WASHER 5/16 SLW
13..	586 07 27-01.....	1	CAP, TANK	27..	539 99 00-55.....	1	WASHER 1/4 SAE FLT
14..	574 86 85-01.....	1	TUBE 10 3/8" SPACER	28..	539 99 01-22.....	2	WASHER 3/8 SAE FLT

WHEELS

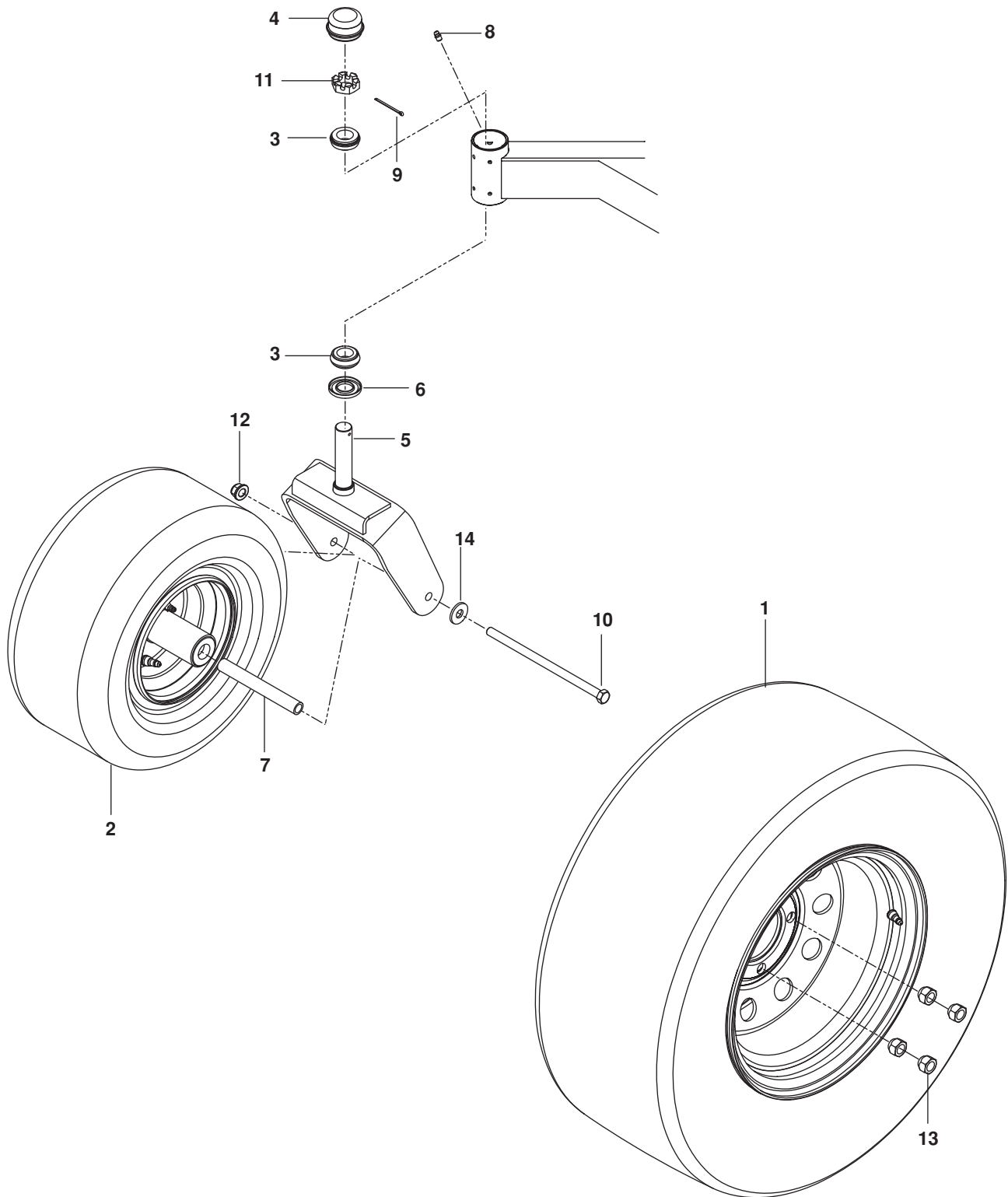

WHEELS

ITEM	PART NO.	QTY.	DESCRIPTION	ITEM	PART NO.	QTY.	DESCRIPTION
1..	586 95 54-01.....	2.....	WHEEL ASSY, 23 x 10.5-12	8..	539 10 14-74.....	2.....	ZERK
2..	581 19 95-01.....	2.....	WHEEL ASSY 13 x 6.5	9..	539 10 28-89.....	2.....	COTTER PIN 1/8 x 2
3..	539 10 25-43.....	4.....	BEARING	10..	539 10 55-17.....	2.....	BOLT 1/2-13 x 9 1/2 HEX HD
4..	539 10 25-35.....	2.....	CAP, GREASE	11..	539 10 28-52.....	2.....	NUT 1"-14 SLOTTED JAM
5..	575 32 92-02.....	2.....	YOKE, CASTER, ORG	12..	521 99 11-01	2.....	NUT 1/2-13 HEX FLG NYLOC
6..	539 10 28-51.....	2.....	SEAL	13..	539 10 11-73.....	8.....	NUT 1/2-20 LUG
7..	575 33 49-01.....	2.....	SPACER, PIVOT	14..	539 10 95-54.....	2.....	WASHER 1/2 FLT

MOWER LIFT / DECK LIFT

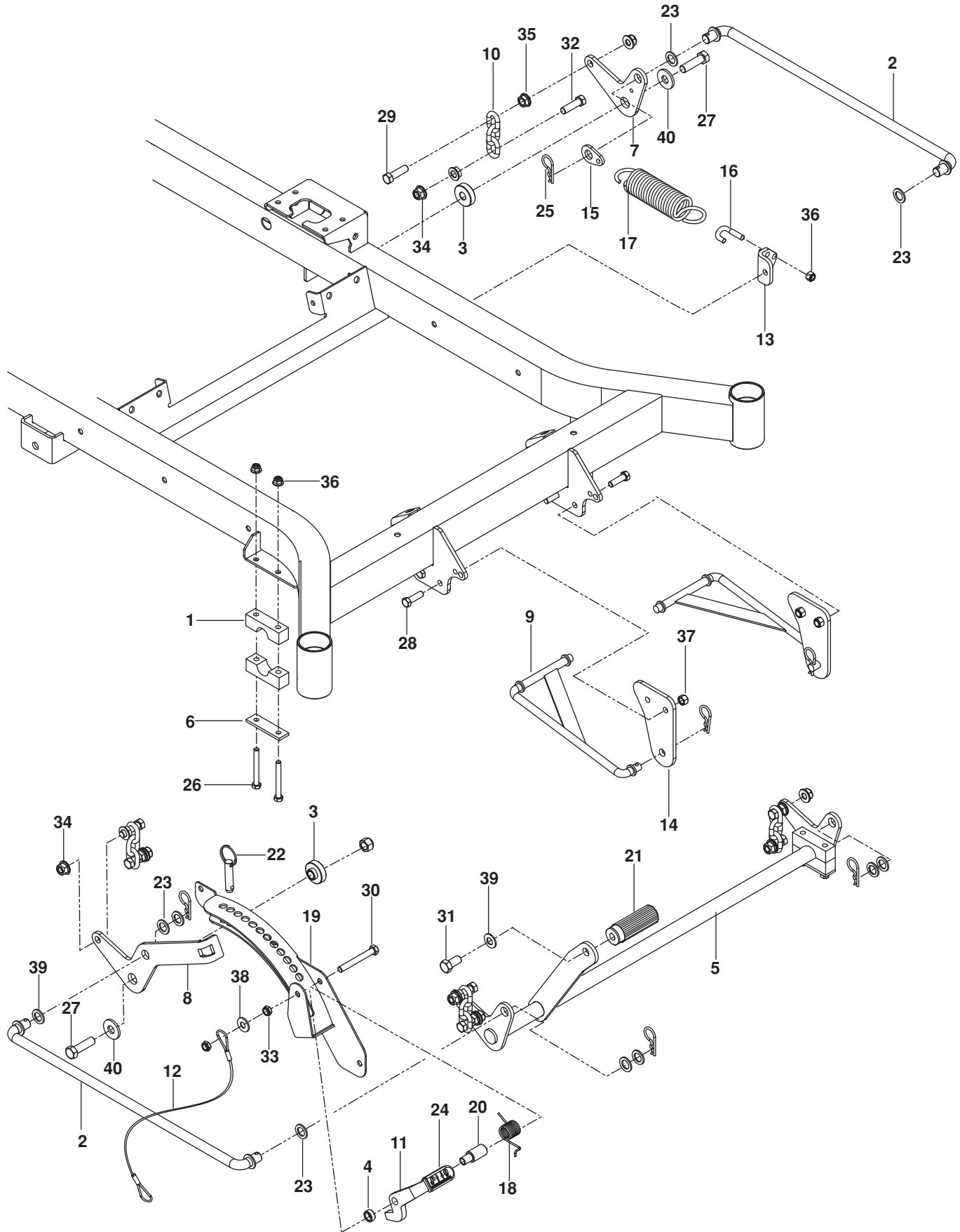

MOWER LIFT / DECK LIFT

ITEM	PART NO.	QTY.	DESCRIPTION	ITEM	PART NO.	QTY.	DESCRIPTION
1..	539 10 48-08.....	4.....	PILLOW BLOCK	21..	510 40 83-01.....	1.....	PEDAL, FOOT
2..	539 11 08-08.....	2.....	LINK, DECK LIFT	22..	539 13 21-82.....	1.....	PIN ½ x 1½ DETENT RING
3..	586 70 17-01.....	2.....	SPACER, IDLER	23..	539 99 10-43.....	10.....	BUSHING .625
4..	539 13 18-61.....	1.....	SPACER	24..	539 13 28-51.....	1.....	GRIP
5..	581 21 52-02.....	1.....	SHAFT, FRONT LIFT BLK	25..	539 11 55-01.....	6.....	PIN, COTTER 1¾
6..	539 10 48-07.....	2.....	REINFORCEMENT BAR	26..	539 10 17-21.....	4.....	BOLT 5/16-18 x 2¾ HEX HD
7..	539 13 18-97.....	1.....	BELLCRANK, RR, LIFT BLK	27..	539 10 81-81.....	2.....	BOLT ½-13 x 1¾ GR 8 HEX HD
8..	539 13 18-53.....	1.....	BELLCRANK, RR, RT BLK	28..	539 97 69-41.....	4.....	BOLT 3/8-16 X 1¼ HEX HD
9..	539 11 22-23.....	2.....	LINKAGE, STRUT	29..	539 10 11-75.....	4.....	BOLT 7/16-14 x 1½ HEX HD
10..	539 10 96-93.....	4.....	LIFT CHAIN-3 LINK	30..	874 78 06-48.....	1.....	BOLT 3/8-16 x 3 HEX HD
11..	539 13 15-66.....	1.....	LATCH, TRANSPORT	31..	539 99 06-46.....	1.....	BOLT ½-13 x 1 HEX HD
12..	539 10 50-59.....	1.....	LANYARD	32..	539 10 80-73.....	4.....	BOLT 7/16-14 x 1¾ HEX HD
13..	539 13 17-91.....	1.....	MOUNT, SPRING	33..	539 20 02-82.....	2.....	NUT 3/8-16 HEX JAM NYLOC
14..	539 13 20-17.....	2.....	MOUNT, STRUT	34..	539 13 20-19.....	8.....	NUT 7/16-14 HEX WHIZ LK
15..	539 13 17-92.....	1.....	TAB, SPRING	35..	539 10 25-82.....	8.....	NUT 7/16-14 HEX WHIZ LK
16..	539 11 28-96.....	1.....	J-BOLT	36..	539 11 28-99.....	5.....	NUT 5/16-18 HEX FLG NYLOC
17..	539 10 26-42.....	1.....	SPRING	37..	539 97 69-79.....	4.....	NUT 3/8-16 HEX NYLOC
18..	539 13 27-34.....	1.....	SPRING, TORSION	38..	819 14 14-16.....	1.....	WASHER 3/8 FLT
19..	539 13 18-50.....	1.....	HEIGHT ADJUST, DECK	39..	539 10 28-43.....	1.....	WASHER 7/16 SPRING
20..	539 13 18-60.....	1.....	PIVOT LATCH, TRANSPORT	40..	539 10 95-54.....	2.....	WASHER ½ FLT

MOWER DECK / CUTTING DECK

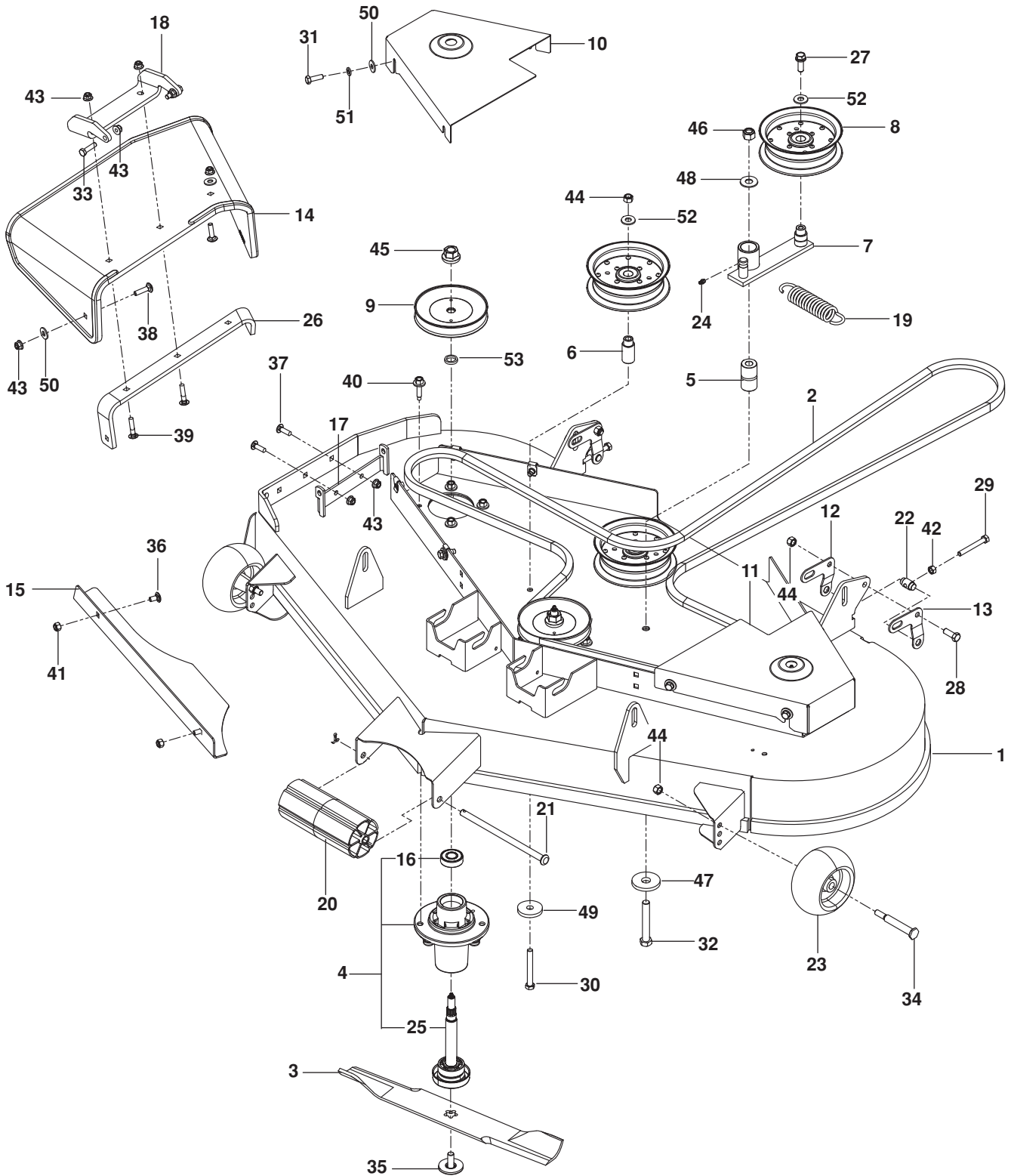

MOWER DECK / CUTTING DECK

ITEM	PART NO.	QTY.	DESCRIPTION	ITEM	PART NO.	QTY.	DESCRIPTION
1..	581 50 53-01.....	1	DECK w/ SAFETY DECALS	28..	874 78 06-16.....	2	BOLT 3/8-16 x 1 HEX HD
2..	522 81 13-01.....	1	BELT, DECK	29..	874 78 05-40.....	2	BOLT 5/16-18 x 2 1/2 TPBLT HX HD
3..	539 11 20-79.....	3	BLADE, 18"	30..	874 78 06-48.....	2	BOLT 3/8-16 x 3 HEX HD
4..	539 13 18-98.....	3	HOUSING ASSY	31..	874 78 05-16.....	8	BOLT 5/16-18 x 1 HEX HD
5..	539 10 34-27.....	1	BUSHING, PIVOT	32..	539 10 34-33.....	1	BOLT 1/2-13 x 3 1/4 HEX HD
6..	539 11 21-69.....	2	BUSHING, IDLER	33..	874 78 05-20.....	2	BOLT 5/16-18 x 1 1/4 HEX HD
7..	539 11 21-98.....	1	ARM, IDLER	34..	532 13 76-44.....	2	BOLT 3/8-16 SHOULDER
8..	539 13 27-28.....	3	PULLEY, IDLER	35..	532 19 30-03.....	3	BOLT 7/16 BLADE
9..	532 17 34-36.....	3	PULLEY	36..	872 11 05-05.....	2	BOLT 5/16-18 x 5/8 RD HD SQNK
10..	539 11 22-42.....	1	BELT SHIELD, RT ORG	37..	872 11 05-08.....	2	BOLT 5/16-18 x 1 RD HD SQNK
11..	539 11 22-44.....	1	BELT SHIELD, LT ORG	38..	539 10 04-72.....	2	BOLT 5/16-18 x 1 1/4 RD HD SQNK
12..	584 85 94-02.....	2	PITCH, ADJUST, RT	39..	872 14 05-12.....	2	BOLT 5/16-18 x 1 1/2 RD HD SQNK
13..	584 85 94-04.....	2	PITCH, ADJUST, LT	40..	584 95 39 01.....	12	SCREW 5/16-18 WSH HD
14..	539 13 09-01.....	1	CHUTE, DISCHARGE	41..	873 80 05-00.....	2	NUT 5/16-18 HEX NYLOC
15..	539 11 24-17.....	1	PLATE, CONFINEMENT	42..	873 22 05-00.....	2	NUT 5/16-18 HEX
16..	532 11 04-85.....	3	BEARING, BALL	43..	539 11 28-99.....	8	NUT 5/16-18 HEX FLG NYLOC
17..	581 60 61-02.....	1	BRACKET ORG	44..	539 97 69-79.....	6	NUT 3/8-16 HEX NYLOC
18..	539 13 09-17.....	1	BRACKET	45..	532 40 02-34.....	3	NUT 9/16 TOP CENTER LOCK
19..	539 10 32-56.....	1	SPRING, TORSION	46..	873 80 08-00.....	1	NUT 1/2 HEX NYLOC
20..	532 17 60-66.....	1	ROLLER, NOSE	47..	539 10 22-43.....	1	WASHER, SUPPORT
21..	532 17 91-27.....	1	ROD, ROLLER, NOSE	48..	539 99 05-50.....	1	WASHER 1/2 STD FLT
22..	539 13 18-59.....	2	TRUNION, PITCH	49..	539 10 65-04.....	2	WASHER, HEAVY
23..	532 13 39-57.....	2	WHEEL, GAUGE	50..	819 12 14-14.....	11	WASHER 5/16 STD FLT
24..	539 97 69-98.....	1	ZERK	51..	810 03 05-00.....	8	WASHER 5/16 SLW
25..	532 18 72-91.....	1	SHAFT	52..	819 14 16-14.....	2	WASHER 3/8 STD FLT
26..	539 13 09-20.....	1	REINFORCEMENT, BRKT	53..	532 18 76-90.....	3	WASHER-SPACER
27..	539 99 05-82.....	1	BOLT 3/8-16 x 1 WHIZLK HX HD				

SEAT

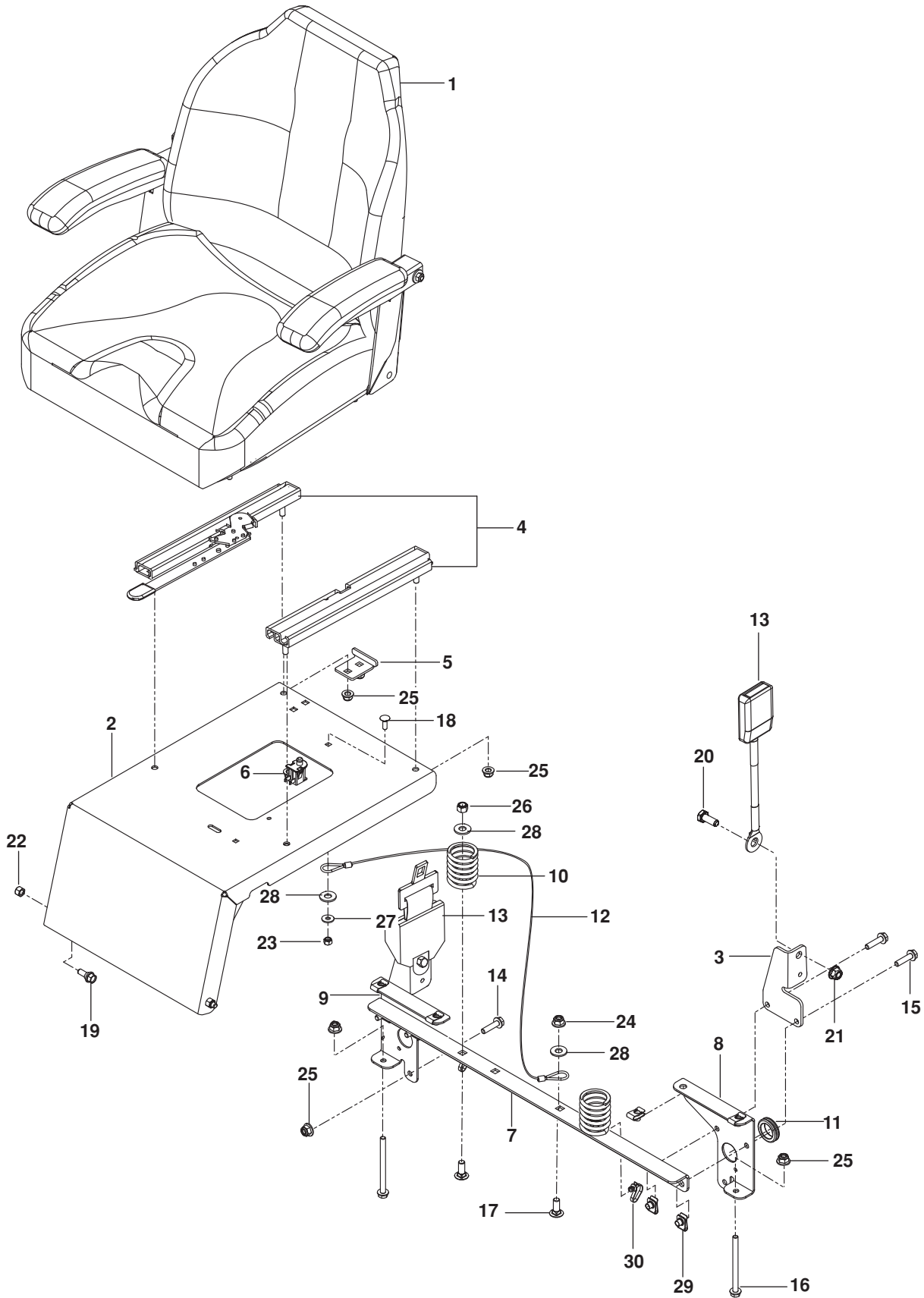

SEAT

ITEM	PART NO.	QTY.	DESCRIPTION	ITEM	PART NO.	QTY.	DESCRIPTION
1..	576 70 20-01.....	1	SEAT	16..	874 49 05-60.....	2	BOLT $\frac{5}{16}$ -18 x $3\frac{3}{4}$ HEX FLG HD
2..	575 60 86-01.....	1	MOUNT, w/ SAFETY DECAL	17..	872 14 06-08.....	3	BOLT $\frac{3}{8}$ -16 x 1 RD HD SQNK
3..	584 91 68-02.....	2	MOUNT, SEAT BELT	18..	872 11 04-06.....	1	BOLT $\frac{1}{4}$ -20 x $\frac{3}{4}$ RD HD SQNK
4..	576 70 20-04.....	1	ASSY, ADJUSTMENT TRACK	19..	539 13 08-96.....	2	BOLT $\frac{5}{16}$ -18 SHOULDER
5..	539 13 07-93.....	1	DECK STOP	20..	539 12 47-75.....	2	BOLT $\frac{7}{16}$ -20 x 1 HEX HD
6..	539 11 97-41.....	1	SWITCH, SEAT	21..	539 99 03-94.....	2	NUT $\frac{7}{16}$ -20 HEX LK
7..	539 13 16-56.....	1	SUPPORT, SEAT BLK	22..	873 80 05-00.....	2	NUT $\frac{5}{16}$ -18 HEX NYLOC
8..	575 22 40-02.....	1	SUPPORT, RT BLK	23..	873 80 04-00.....	1	NUT $\frac{1}{4}$ -20 HEX NYLOC
9..	575 22 41-02.....	1	SUPPORT, LT BLK	24..	521 99 65-01.....	1	NUT $\frac{3}{8}$ -16 HEX FLG NYLOC
10..	532 12 41-81.....	2	SPRING, SEAT BLK	25..	539 11 28-99.....	10	NUT $\frac{5}{16}$ -18 HEX FLG NYLOC
11..	539 10 59-74.....	1	GROMMET RUBBER	26..	873 80 06-00.....	2	NUT $\frac{3}{8}$ -16 HEX NYLOC
12..	539 10 32-47.....	1	LANYARD, SEAT	27..	819 09 12-16.....	1	WASHER $\frac{1}{4}$ FLT
13..	539 13 03-59.....	1	SEAT BELT ASSY	28..	819 14 16-14.....	4	WASHER $\frac{3}{8}$ FLT STD
14..	525 46 47-01.....	2	BOLT $\frac{5}{16}$ -18 x $\frac{3}{4}$ HEX FLG HD	29..	539 10 47-63.....	8	RETAINER, U TYPE $\frac{5}{16}$ -18
15..	525 54 40-01.....	4	BOLT $\frac{5}{16}$ -18 x $1\frac{1}{4}$ HEX FLG HD	30..	505 28 00-01.....	2	TIE WRAP w/ CLIP

DECALS

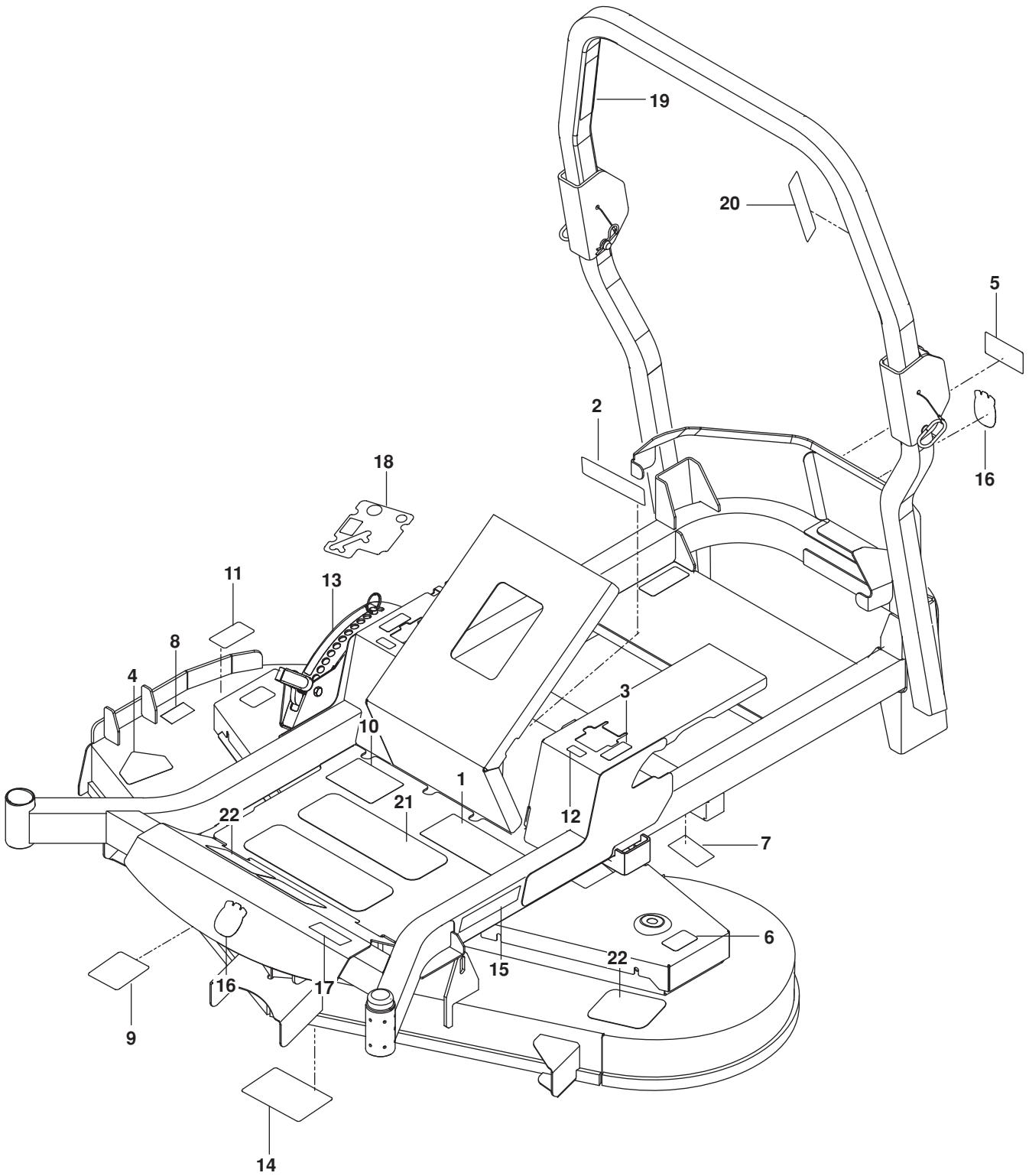

DECALS

ITEM	PART NO.	QTY.	DESCRIPTION	ITEM	PART NO.	QTY.	DESCRIPTION
1..	539 10 79-59.....	1	DECAL, WARNING	12..	539 11 09-74.....	2	DECAL, TRACKING
2..	539 10 57-45.....	1	DECAL, BATTERY WARNING	13..	539 13 20-39.....	1	DECAL, HEIGHT ADJUST
3..	539 10 33-33.....	2	DECAL, MOTION CONTROL	14..	539 13 21-87.....	1	DECAL, SERVICE
4..	584 90 46-01.....	1	DECAL, BLADE WARNING	15..	532 42 91-96.....	2	DECAL, HUSQVARNA
5..	539 10 57-44.....	1	DECAL, DANGER BLT DRIVE	16..	532 42 86-76.....	2	DECAL, CROWN H
6..	539 10 57-43.....	2	DECAL, NO STEP	17..	581 51 36-01.....	1	DECAL, M-ZT52
7..	581 51 37-01.....	1	DECAL, HYDROGEAR	18..	574 84 11-03.....	1	DECAL, CONSOLE
8..	539 10 57-46.....	1	DECAL, SEVERING	19..	574 56 90-02.....	1	DECAL, ROPS, WARNING
9..	539 11 26-20.....	1	DECAL, BELT ROUTING	20..	574 56 90-05.....	1	DECAL.ROPS
10..	586 34 25-01.....	1	DECAL, START	21..	539 97 77-78.....	2	PAD, ABRASIVE LG
11..	581 72 44-01.....	1	DECAL, DEFLECTOR	22..	539 12 13-22.....	3	PAD, ABRASIVE SM

PROTECTION FRAME

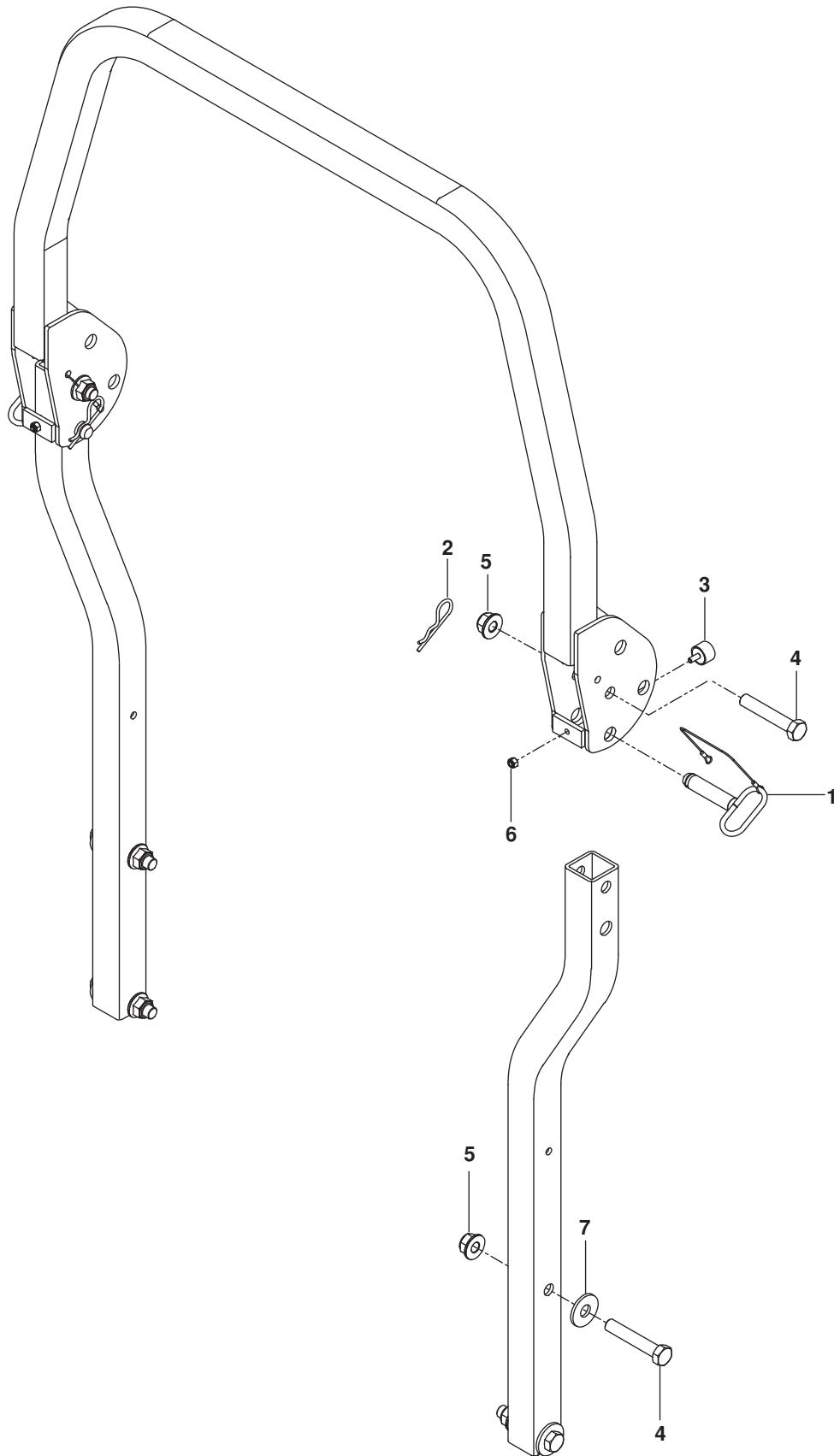

PROTECTION FRAME

ITEM	PART NO.	QTY.	DESCRIPTION	ITEM	PART NO.	QTY.	DESCRIPTION
1..	574 38 80-01.....	2.....	PIN w/ CABLE	5..	525 82 91-01.....	6.....	NUT $\frac{5}{8}$ -11 FLG NYLOC
2..	539 20 07-15.....	2.....	HAIR PIN #210	6..	873 80 04-00.....	2.....	NUT $\frac{1}{4}$ -20 HEX NYLOC
3..	522 80 14-01.....	2.....	BUMPER, MALE STUD $\frac{1}{4}$ -20	7..	539 10 26-53.....	4.....	WASHER $\frac{5}{8}$ STD FLT
4..	580 75 46-01.....	6.....	BOLT $\frac{5}{8}$ -11 x $3\frac{1}{2}$ HEX HD				

ACCESSORIES

BLOWER ASSEMBLY

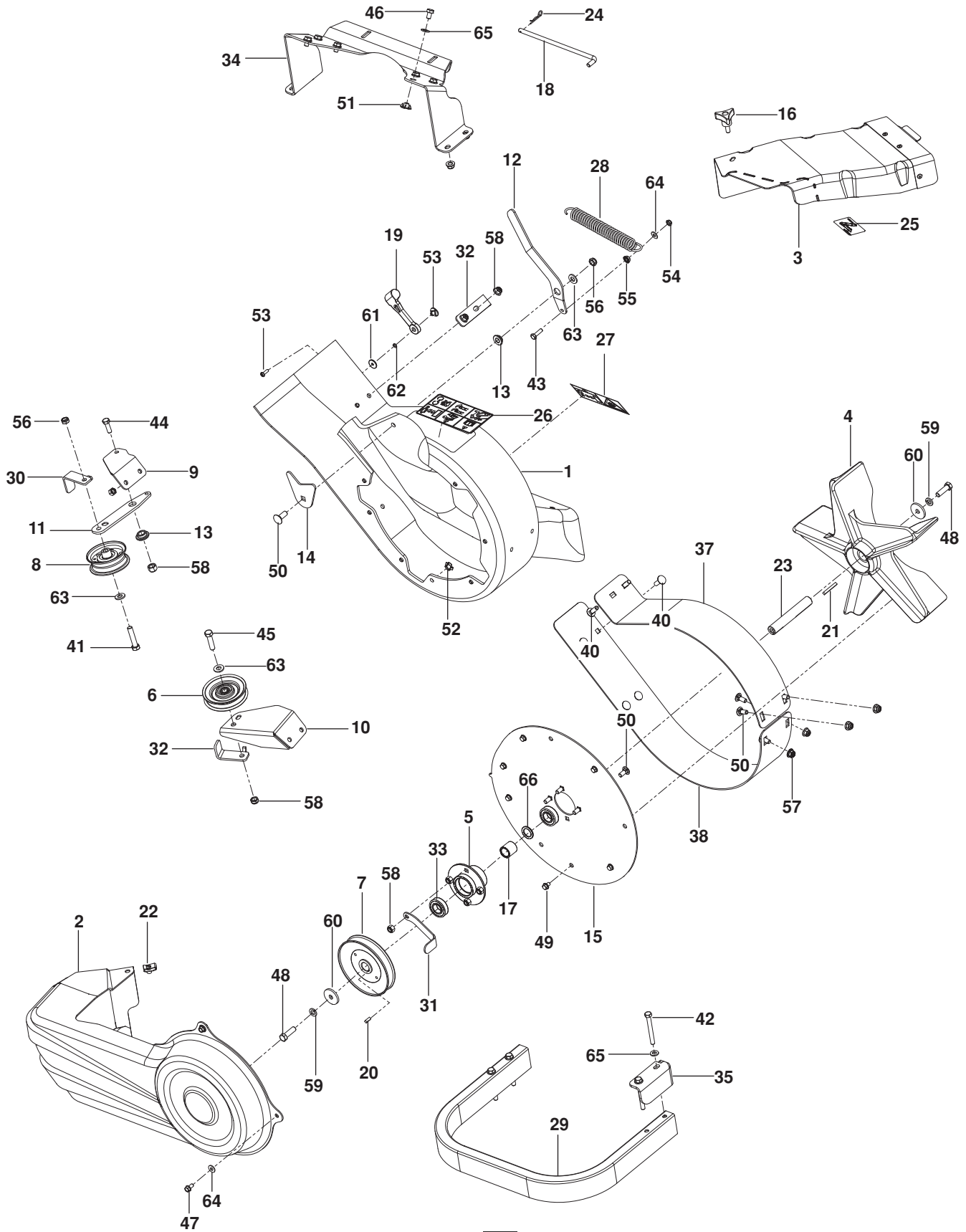

ACCESSORIES

ITEM	PART NO.	QTY.	DESCRIPTION	ITEM	PART NO.	QTY.	DESCRIPTION
1..	539 13 03-44.....	1	HOUSING w/DECALS	34..	522 90 96-02.....	1	BRACKET, MOUNT
2..	539 13 02-93.....	1	COVER, BELT	35..	522 90 95-02.....	1	BRACKET, RETENTION
3..	574 41 15-01.....	1	COVER, BELT	36..	525 61 83-02.....	1	SAND LINER, TOP
4..	539 13 02-92.....	1	IMPELLER	37..	522 90 97-02.....	1	SAND LINER, BOTTOM
5..	539 13 02-95.....	1	HUB	38..	539 99 06-45.....	1	BOLT $\frac{3}{8}$ -16 x 1 RD HD SQNK
6..	539 11 36-83.....	1	PULLEY, V-IDLER	39..	539 99 03-16.....	6	BOLT $\frac{5}{16}$ -18 x $\frac{3}{4}$ RD HD SQNK
7..	539 13 03-24.....	1	PULLEY	40..	539 99 02-08.....	6	BOLT $\frac{5}{16}$ -18 x 1 RD HD SQNK
8..	579 15 08-02.....	1	PULLEY, IDLER	41..	539 97 69-49.....	1	BOLT $\frac{3}{8}$ -16 x 1 $\frac{3}{4}$ HEX HD
9..	579 13 74-02.....	1	MOUNT, UPPER BLK	42..	539 10 17-21.....	4	BOLT $\frac{5}{16}$ -18 x 2 $\frac{3}{4}$ HEX HD
10..	579 13 75-02.....	1	MOUNT, LOWER BLK	43..	539 99 06-43.....	1	BOLT $\frac{1}{4}$ -20 x $\frac{7}{8}$ HEX HD
11..	579 13 73-02.....	1	ARM, IDLER	44..	539 99 02-09.....	1	BOLT $\frac{5}{16}$ -18 x 1 HEX HD
12..	539 13 03-38.....	1	ARM, TENSION	45..	539 99 06-55.....	1	BOLT $\frac{3}{8}$ -16 x 1 $\frac{1}{2}$ HEX HD
13..	539 13 03-01.....	2	BUSHING	46..	539 13 03-15.....	6	BOLT $\frac{5}{16}$ -18 x $\frac{1}{2}$ HEX HD
14..	539 13 21-24.....	1	PLATE, BACKING	47..	539 10 84-61.....	3	BOLT $\frac{1}{4}$ -20 x $\frac{1}{2}$ HWST
15..	539 13 03-41.....	1	PLATE, OUTER	48..	539 11 03-21.....	2	BOLT $\frac{3}{8}$ -24 x 1 $\frac{1}{4}$ HEX GR 8
16..	539 10 44-11.....	1	KNOB w/ STUD	49..	539 99 03-02.....	8	SCREW $\frac{1}{4}$ -20 x $\frac{3}{8}$ THD FRM
17..	539 13 03-23.....	1	SPACER	50..	539 97 69-52.....	1	SCREW #10-24 x $\frac{5}{8}$ MACH
18..	522 90 98-01.....	1	PIN, RETENTION	51..	539 13 03-13.....	6	NUT $\frac{5}{16}$ -18 TEE
19..	539 10 80-88.....	1	LATCH, HOOD	52..	539 13 03-14.....	9	NUT $\frac{1}{4}$ -20 TEE
20..	539 11 56-67.....	1	KEY $\frac{3}{16}$ x $\frac{1}{2}$	53..	539 10 80-89.....	1	WELDNUT, PLATED
21..	539 12 52-29.....	1	KEY 1 $\frac{1}{2}$	54..	539 10 81-20.....	1	NUT $\frac{1}{4}$ -20 HEX THIN NYLOC
22..	539 10 47-63.....	1	RETAINER, U TYPE	55..	539 10 87-35.....	1	NUT $\frac{1}{4}$ -20 HEX FLG LK
23..	539 13 03-16.....	1	SHAFT, IMPELLER	56..	539 20 02-82.....	3	NUT $\frac{3}{8}$ -16 HEX JAM NYLOC
24..	539 97 69-88.....	1	HAIRPIN COTTER	57..	539 11 28-99.....	10	NUT $\frac{5}{16}$ -18 HEX FLG NYLOC
25..	539 13 03-49.....	1	DECAL, BELT ROUTING	58..	539 99 07-17.....	9	NUT $\frac{5}{16}$ -18 HEX NYLOC
26..	539 10 57-85.....	1	DECAL, WARNING	59..	539 99 01-18.....	2	WASHER $\frac{3}{8}$ SLW
27..	539 10 67-41.....	1	DECAL, SEVERING	60..	532 14 02-96.....	2	WASHER, HARDENED
28..	539 10 19-77.....	1	SPRING, TRACTION	61..	539 10 80-84.....	1	WASHER $\frac{3}{16}$ x $\frac{3}{4}$ x 16 GA
29..	522 90 94-02.....	1	TUBE, RUB	62..	539 10 95-52.....	1	WASHER $\frac{3}{16}$ SLW
30..	579 13 76-02.....	1	KEEPER, BELT REAR BLK	63..	539 99 01-22.....	3	WASHER $\frac{3}{8}$ SAE FLT
31..	539 13 10-85.....	1	KEEPER, BELT OUTER BLK	64..	539 99 00-55.....	4	WASHER $\frac{1}{4}$ FLT SAE
32..	579 13 77-02.....	1	KEEPER	65..	819 11 11-16.....	10	WASHER $\frac{5}{16}$ SAE FLT
33..	539 13 02-96.....	2	BEARING				

ACCESSORIES

CHUTES

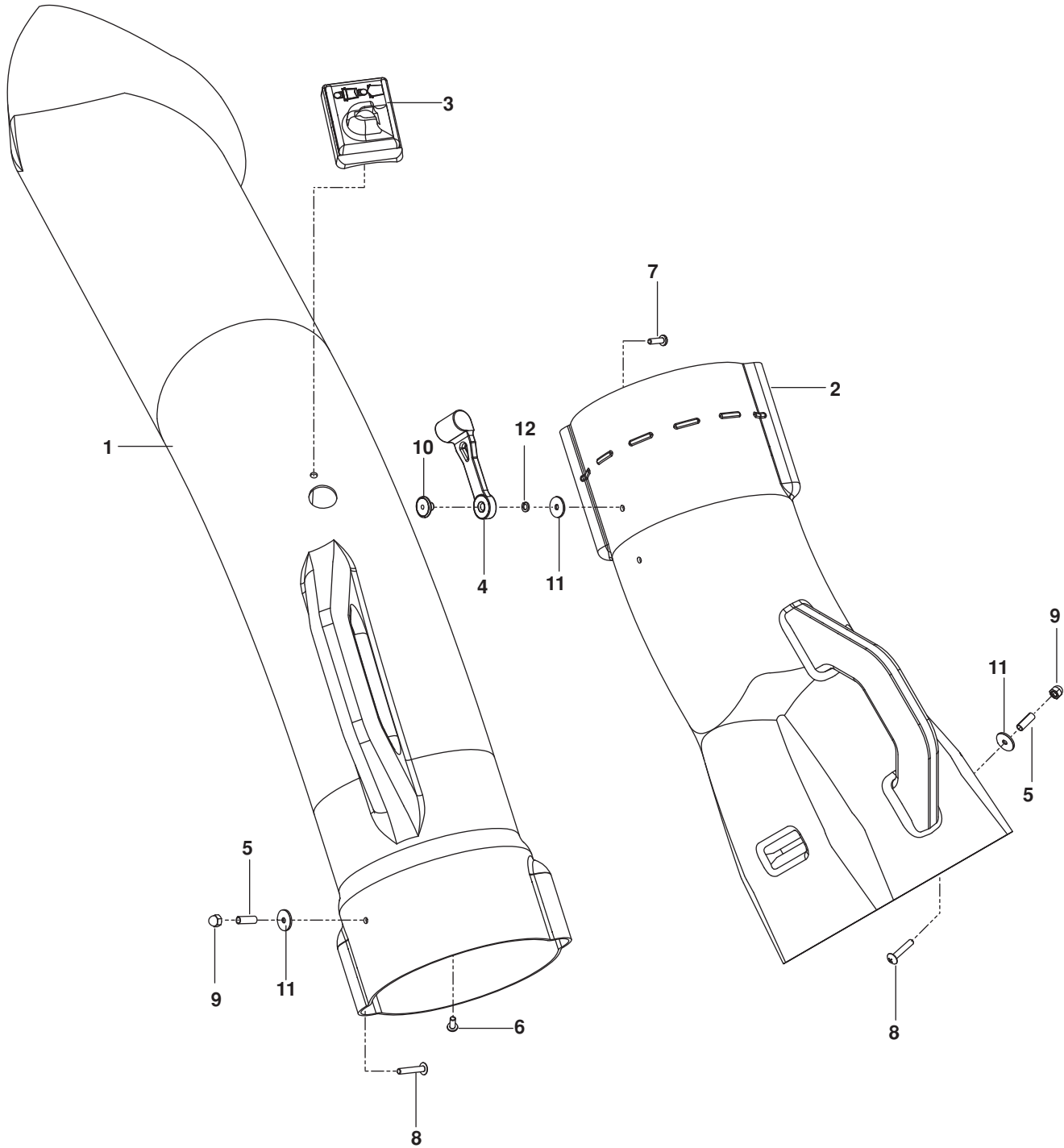

ACCESSORIES

ITEM	PART NO.	QTY.	DESCRIPTION	ITEM	PART NO.	QTY.	DESCRIPTION
1..	539 10 81-41.....	1	CHUTE, UPPER	7..	539 97 69-52.....	1	SCREW #10-24 x 5/8
2..	539 13 02-94.....	1	CHUTE, MIDDLE	8..	539 10 80-83.....	2	SCREW #10-24 x 1 1/8
3..	539 13 09-33.....	1	INDICATOR, BAG DUMP	9..	539 10 80-86.....	2	NUT #10-24 ACORN
4..	539 10 80-88.....	1	LATCH, HOOD	10..	539 10 80-89.....	1	WELDNUT, PLATED
5..	539 10 80-85.....	2	SPACER, SPLIT	11..	539 10 80-84.....	3	WASHER 3/16 x 3/4 x 16 GA
6..	539 10 80-81.....	1	SCREW #10-14 x 1/2	12..	539 10 95-52.....	2	WASHER 3/16 LOCK

ACCESSORIES

BAGGER

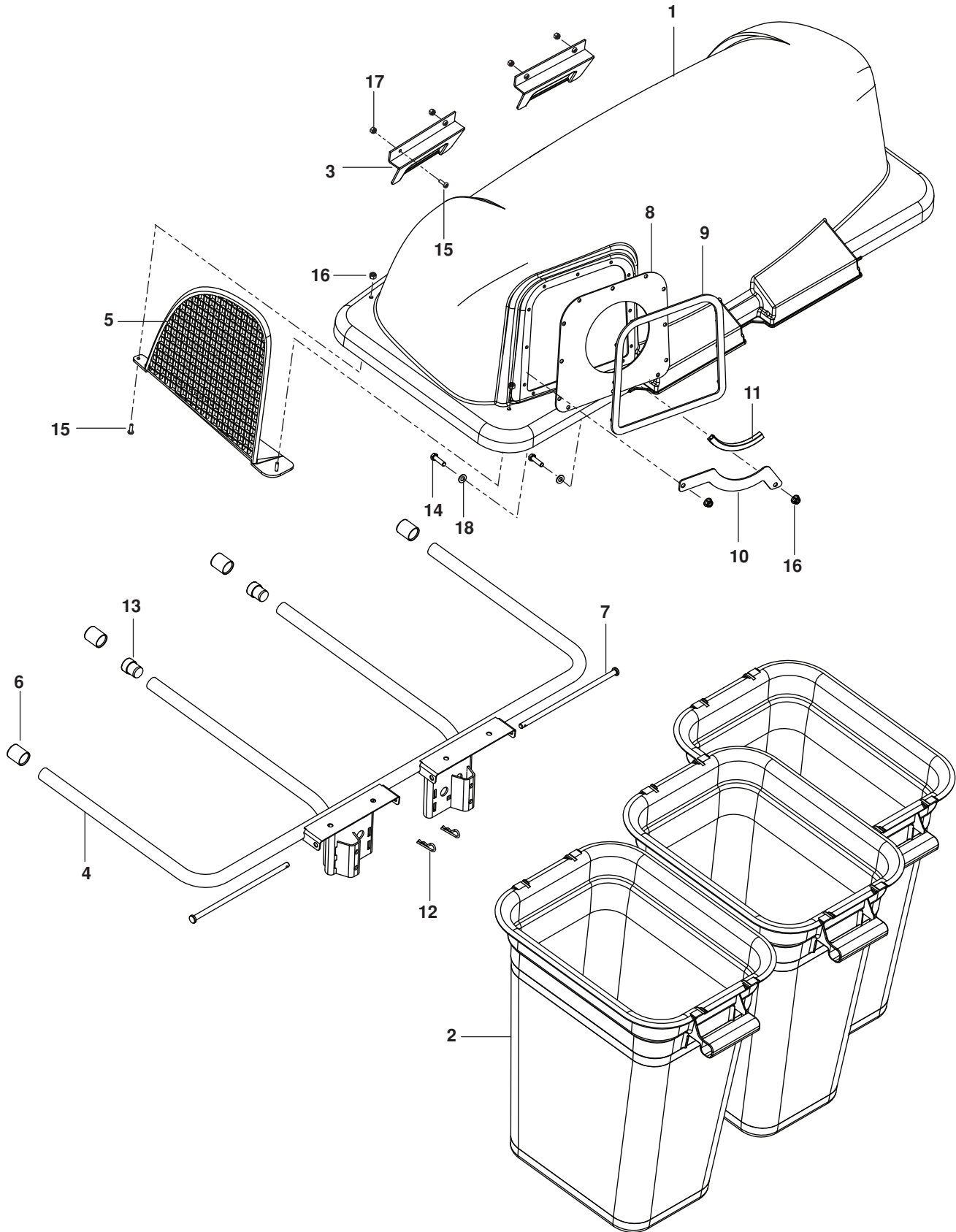

ACCESSORIES

ITEM	PART NO.	QTY.	DESCRIPTION	ITEM	PART NO.	QTY.	DESCRIPTION
1..	532 19 53-73.....	1	COVER	10..	539 11 02-81.....	1	SUPPORT, CHUTE
2..	532 40 02-26.....	3	CONTAINER, SOFT BAG	11..	539 11 22-94.....	1	FLEX TRIM
3..	532 13 08-95.....	2	HANDLE, BAGGER COVER	12..	539 10 80-96.....	2	HAIR PIN
4..	532 17 69-90.....	1	FRAME, BAGGER	13..	522 80 13-01.....	2	PLUG
5..	532 19 27-09.....	1	SCREEN, COVER	14..	539 99 06-27.....	2	BOLT $\frac{5}{16}$ -18 x $1\frac{1}{4}$ HEX HD
6..	532 17 40-83.....	2	PLUG, SPACER	15..	539 97 69-52.....	6	SCREW #10-24 x $\frac{5}{8}$
7..	532 19 27-86.....	2	PIN, HINGE	16..	539 11 28-99.....	2	NUT $\frac{5}{16}$ -18 HEX FLG NYLOC
8..	532 19 25-50.....	1	SEAL, COVER	17..	539 97 69-77.....	6	NUT #10-24 CROWNLOCK
9..	532 19 26-03.....	1	GASKET, COVER	18..	819 11 11-16.....	4	WASHER $\frac{5}{16}$ SAE FLT

ACCESSORIES

MOUNT, GUARD, BELT

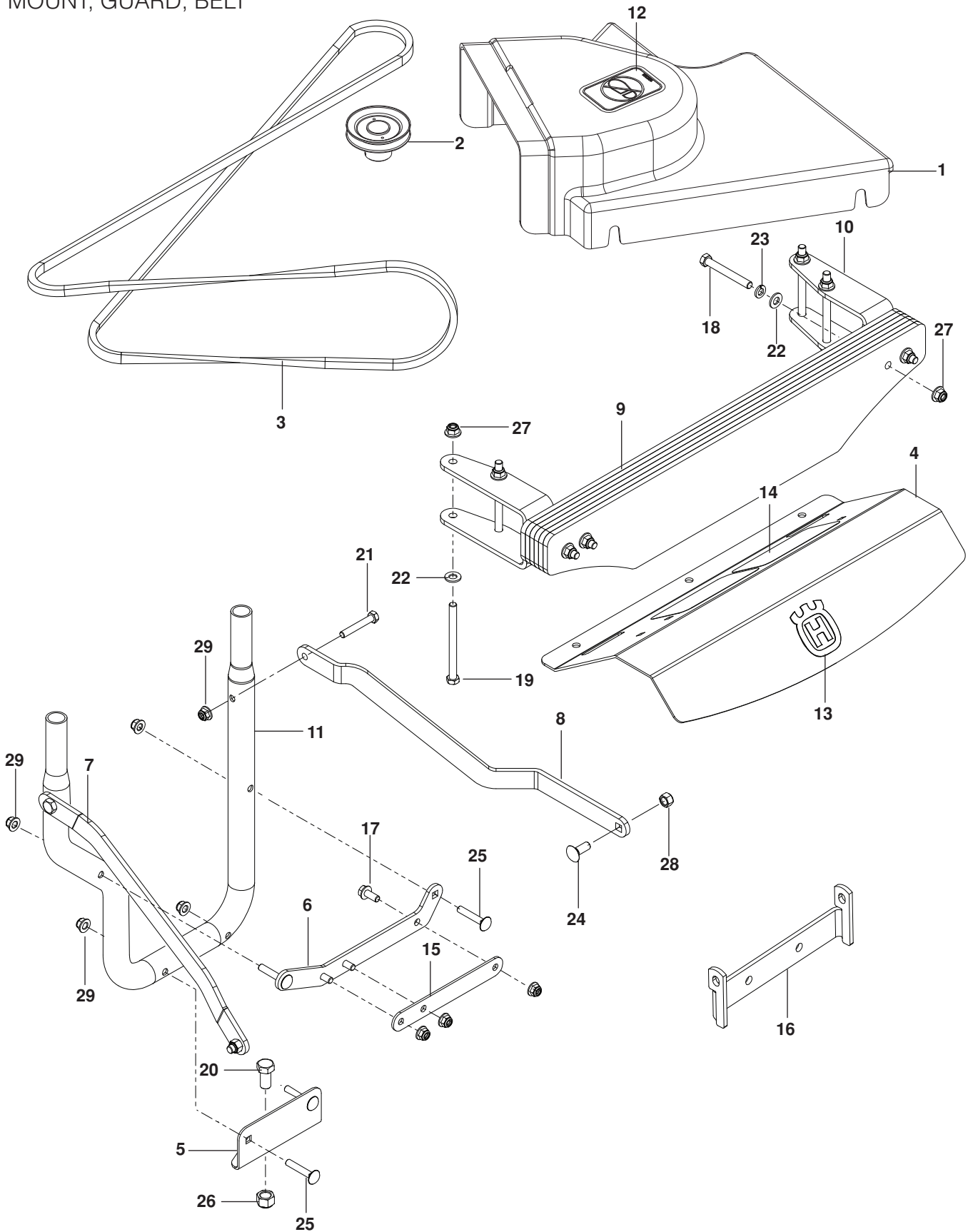

ACCESSORIES

ITEM	PART NO.	QTY.	DESCRIPTION	ITEM	PART NO.	QTY.	DESCRIPTION
1..	539 13 03-07.....	1SHIELD, BELT	17..	525 46 47-01	3BOLT $\frac{5}{16}$ -18 x $\frac{3}{4}$ HEX FLG HD
2..	539 13 03-20.....	1PULLEY	18..	539 10 13-41.....	4BOLT $\frac{3}{8}$ -16 x 3 HEX HD
3..	539 13 03-47.....	1BELT	19..	539 10 23-34.....	4BOLT $\frac{3}{8}$ -16 x $4\frac{1}{2}$ HEX HD
4..	584 81 20-02.....	1FOOT REST	20..	539 99 06-46.....	1BOLT $\frac{1}{2}$ -13 x 1 HEX HD
5..	539 13 21-92.....	1MOUNT, HITCH	21..	539 97 69-37	2BOLT $\frac{5}{16}$ -18 x 2 HEX HD
6..	576 22 14-02.....	1BRACKET, SUPPORT	22..	539 99 01-22	8WASHER $\frac{3}{8}$ SAE FLT
7..	539 13 21-98	1STRAP, RT BLK	23..	539 99 01-18	4WASHER $\frac{3}{8}$ LK
8..	575 95 33-02.....	1STRAP, LT BLK	24..	539 99 06-45.....	2BOLT $\frac{3}{8}$ -16 x 1 RD HD SQNK
9..	539 11 32-32.....	6PLATE, WEIGHT	25..	539 99 08-61.....	4BOLT $\frac{5}{16}$ -18 x $1\frac{3}{4}$ RD HD SQNK
10..	522 98 90-02.....	2BRACKET, WEIGHT	26..	539 10 13-31.....	1NUT $\frac{1}{2}$ -13 HEX NYLOC
11..	539 13 10-91	1TUBE, MOUNT	27..	521 96 65-01.....	8NUT $\frac{3}{8}$ -16 HEX FLG NYLOC
12..	539 10 57-43.....	1DECAL, NO STEP	28..	539 976979.....	2NUT $\frac{3}{8}$ -16 HEX NYLOC
13..	532 42 86-76.....	1DECAL, CROWN	29..	539 11 28-99.....	9NUT $\frac{5}{16}$ -18 HEX FLG NYLOC
14..	539 12 13-22.....	2ABRASIVE PAD	NOT SHOWN			
15..	576 22 15-02.....	1SPACER		539 11 02-90.....	1BLOCK, FOAM
16..	581 60 61-04.....	1BRACKET, CHUTE BLK				

ACCESSORIES

MULCH KIT

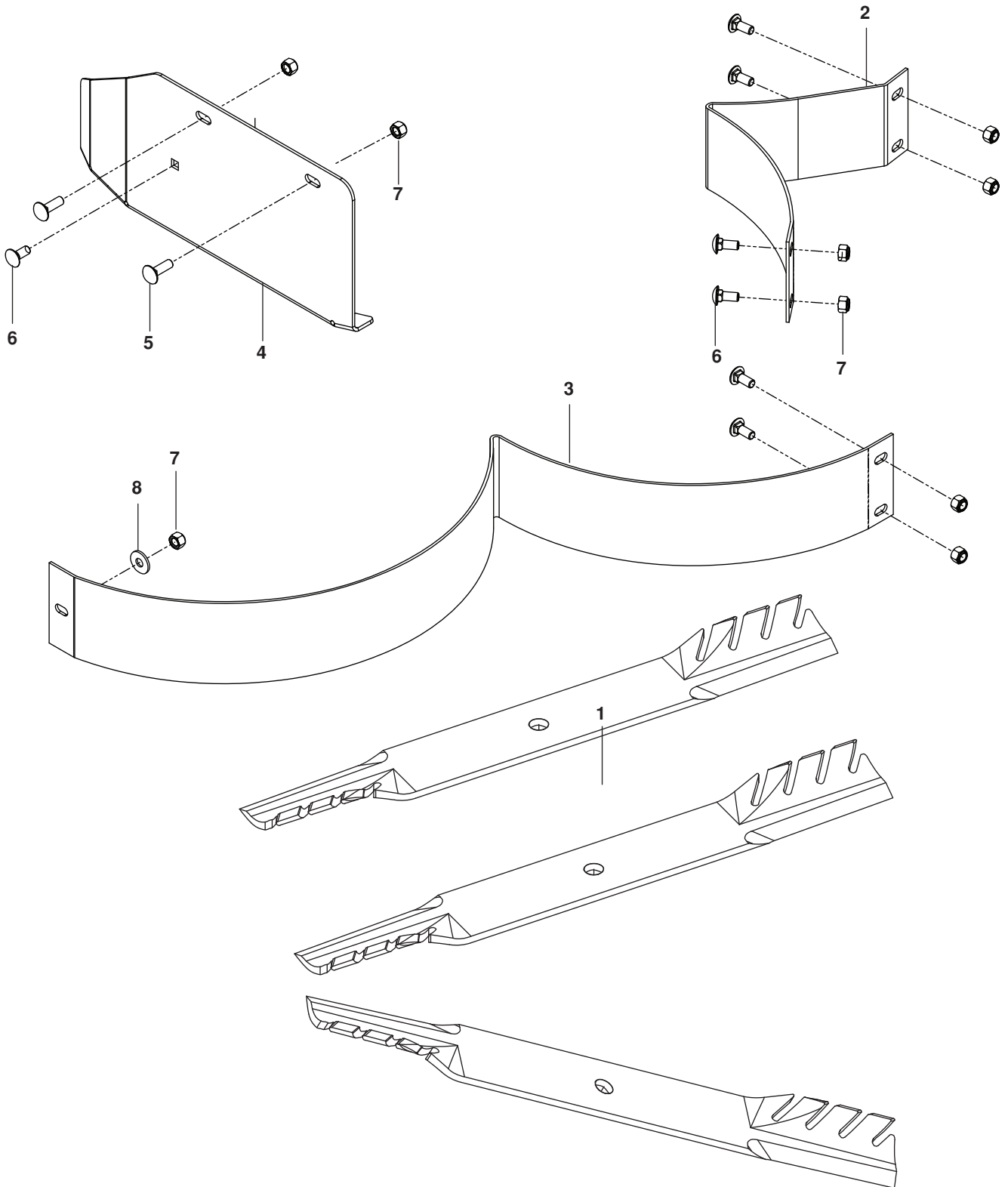

ACCESSORIES

ITEM	PART NO.	QTY.	DESCRIPTION
1..	521 98 15-01.....	3.....	BLADE, 21" GATOR
2..	539 11 24-21.....	1.....	BAFFLE, LEFT
3..	539 11 24-35.....	1.....	BAFFLE, RIGHT
4..	539 11 23-44.....	1.....	MULCH CAP

ITEM	PART NO.	QTY.	DESCRIPTION
5..	539 99 02-08.....	2.....	BOLT ⁵ / ₁₆ -18 x 1 RD HD SQNK
6..	539 99 03-16.....	7.....	BOLT ⁵ / ₁₆ -18 x ³ / ₄ RD HD SQNK
7..	539 99 07-17.....	9.....	NUT ⁵ / ₁₆ -18 NYLOC
8..	539 99 06-92.....	1.....	WASHER ⁵ / ₁₆

www.husqvarna.com

115 71 64-27 Rev A
2014-09-01