

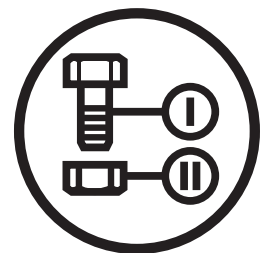

Parts Manual

MZ 61

Zero Turn Mower / 967277502-01



Please read the operator manual carefully and make sure you understand the instructions before using the machine.

When you need spare parts or support in service questions, warranty issues, etc., please consult the following professional:

This manual belongs to the machine with the manufacturing number:	Engine	Transmission

Manufacturing Number

The machine's manufacturing number can be found on the printed plate affixed to the engine compartment.

Stated on the plate, from the top are:

- The machine's type designation (I.D.).
- The manufacturer's type number (Model).
- The machine's serial number (Serial no.)

Please have the type designation and serial number available when ordering spare parts.

The engine's manufacturing number is stamped on one of the valve covers.

The plate states:

- The engine's model.
- The engine's type.
- Code

Please have these available when ordering spare parts.

The wheel motors and hydrostatic pumps have a barcode decal affixed at the rear.

Accessories Available	
Collection System -----	966 79 31-01
Mulch Kit -----	965 89 40-02

CONTENTS

FRAME.....	4
ENGINE PLATE.....	6
STEERING	8
IGNITION.....	10
PARK BRAKE.....	12
HYDRAULIC PUMP-MOTOR.....	14
WHEELS	16
MOWER LIFT / DECK LIFT	18
MOWER DECK / CUTTING DECK.....	20
SEAT	22
DECALS.....	24
ACCESSORIES.....	26
Blower.....	26
Bagger.....	28
Guard, Mount and Belt	30
Mulch Kit.....	32

Illustrations may or may not represent the actual assemblies and it is not recommended to use this manual as a guide to assemble or disassemble the mower.

NOTE: All fasteners are Grade 5 unless otherwise specified.

FRAME

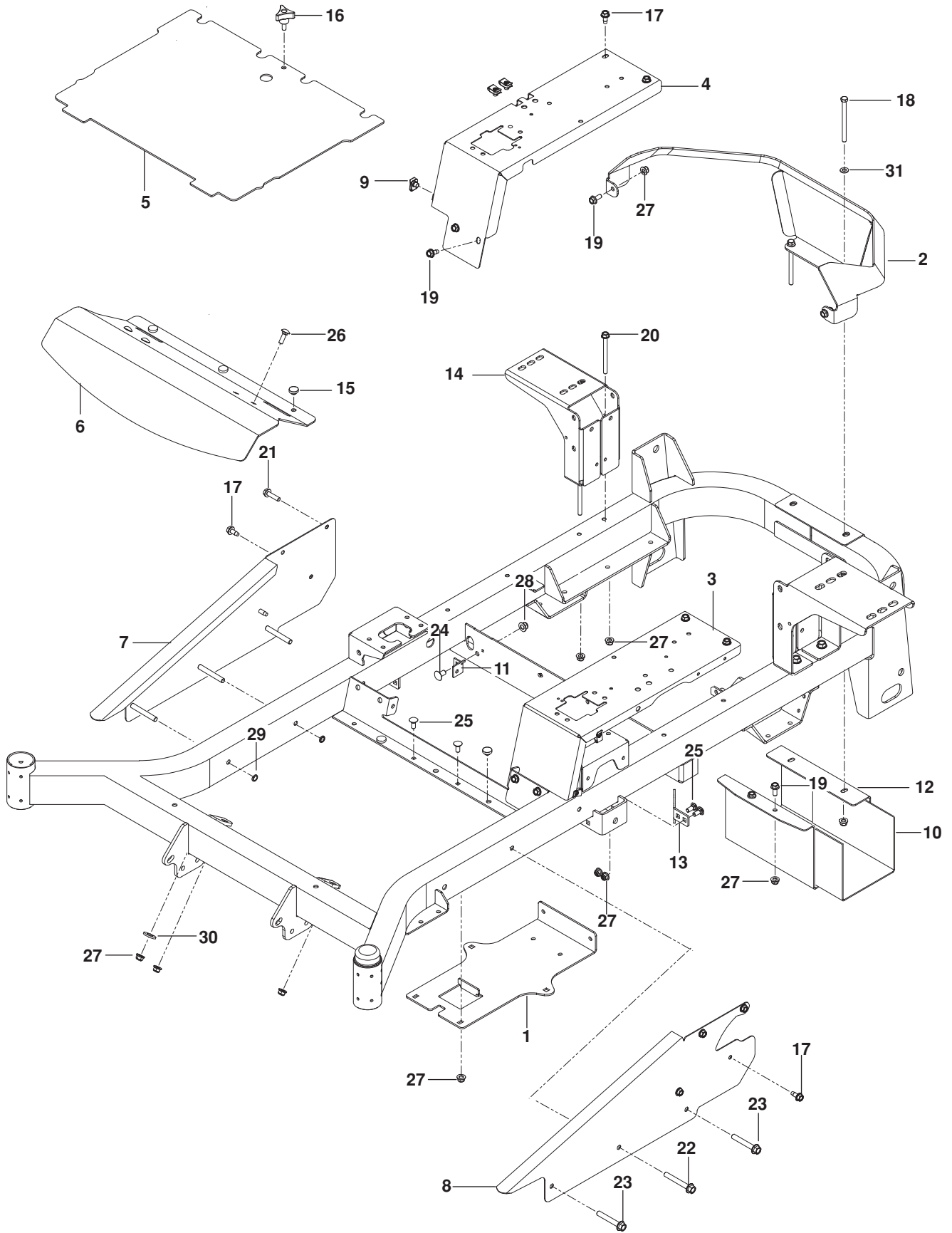

FRAME

ITEM	PART NO.	QTY.	DESCRIPTION	ITEM	PART NO.	QTY.	DESCRIPTION
1..	575 01 72-02.....	1	PLATE, BATTERY, BLK	17..	539 10 74-75.....	12	BOLT $\frac{5}{16}$ -18 x $\frac{3}{4}$ THD FRM
2..	575 34 84-02.....	1	GUARD, REAR GRY	18..	539 10 23-35.....	2	BOLT $\frac{5}{16}$ -18 x 4 HEX HD
3..	577 25 68-02.....	1	PANEL, LT ORG	19..	525 46 47-01.....	5	BOLT $\frac{5}{16}$ -18 x $\frac{3}{4}$ HEX FLG HD
4..	577 25 69-02.....	1	PANEL, RT ORG	20..	874 49 05 60.....	4	BOLT $\frac{5}{16}$ -18 x $3\frac{3}{4}$ HEX FLG HD
5..	539 13 27-44.....	1	PLATE w/ SAFTY DECAL	21..	525 54 40-01.....	1	BOLT $\frac{5}{16}$ -18 x $1\frac{1}{4}$ HEX FLG HD
6..	539 13 23-80.....	1	PLATE, FOOTREST ORG	22..	539 13 17-81.....	2	BOLT $\frac{3}{8}$ -16 x $2\frac{3}{4}$ HEX FLG HD
7..	539 13 15-79.....	1	SIDE, RT ORG	23..	539 13 30-06.....	4	BOLT $\frac{3}{8}$ -16 x $2\frac{1}{2}$ HEX FLG HD
8..	539 13 15-77.....	1	SIDE, LT ORG	24..	539 10 91-17.....	2	BOLT $\frac{3}{8}$ -16 x $\frac{3}{4}$ RD HD SQNK
9..	539 10 47-63.....	8	RETAINER, U TYPE $\frac{5}{16}$ -18	25..	539 99 03-16.....	6	BOLT $\frac{5}{16}$ -18 x $\frac{3}{4}$ RD HD SQNK
10..	539 13 28-59.....	1	SHIELD, HEAT	26..	539 99 02-08.....	3	BOLT $\frac{5}{16}$ -18 x 1 RD HD SQNK
11..	575 24 52-02.....	2	BRACKET, DAMPENER	27..	539 11 28-99.....	12	NUT $\frac{5}{16}$ -18 HEX FLANGE NYL
12..	575 23 04-02.....	1	SHIELD, MUFFLER BLK	28..	521 99 65-01.....	2	NUT $\frac{3}{8}$ -16 HEX FLG NYLOC
13..	505 25 64-01.....	2	STOP, DECK	29..	539 20 02-82.....	6	NUT $\frac{3}{8}$ -16 HEX JAM NYLOC
14..	575 53 36-02.....	2	MOUNT, TANK BLK	30..	539 99 02-50.....	1	WASHER
15..	539 10 25-87.....	5	BUMPER	31..	819 11 11-16.....	2	WASHER $\frac{5}{16}$ SAE FLAT
16..	539 10 44-11.....	1	KNOB w/ STUD				

ENGINE PLATE

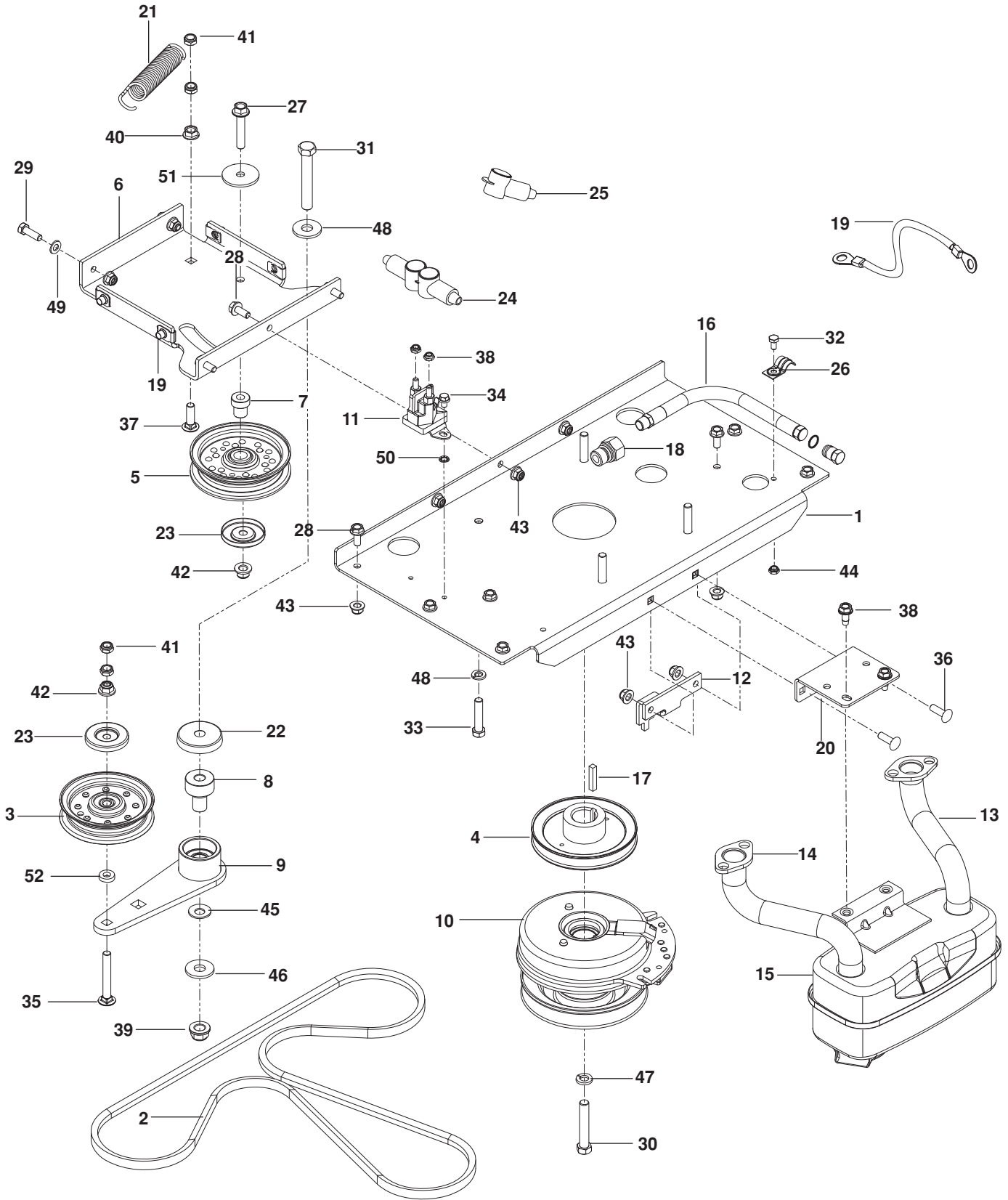

ENGINE PLATE

ITEM	PART NO.	QTY.	DESCRIPTION	ITEM	PART NO.	QTY.	DESCRIPTION
1..	575 60 88-01.....	1	PLATE, ENGINE w/ DECAL	31..	874 78 08-52.....	1	BOLT 1/2-13 x 3/4
2..	574 87 09-01.....	1	BELT	32..	874 78 04-08.....	1	BOLT 1/4-20 x 1/2
3..	532 17 58-20.....	1	PULLEY, IDLER SECONDARY	33..	874 78 06-16.....	4	BOLT 3/8-16 x 1
4..	574 81 10-01.....	1	PULLEY, V 1 1/8 BORE	34..	817 49 04-06.....	1	SCREW 1/4-20 x 8 THD FRM
5..	539 97 66-88.....	1	PULLEY, IDLER	35..	872 14 06-22.....	1	BOLT 3/8-16 x 2 3/4 RD HD SQNK
6..	574 84 64-02.....	1	PLATE, IDLER SUPPORT	36..	872 11 05-08.....	2	BOLT 5/16-18 x 1 RD HD SQNK
7..	525 43 56-01.....	1	PIVOT, IDLER	37..	872 14 06-10.....	1	BOLT 3/8-16 x 1 1/4 RD HD SQNK
8..	510 20 63-01.....	1	PIVOT, BEARING	38..	817 49 05-12.....	2	SCREW 5/16-18 x 3/4 THD FRM
9..	510 04 16-03.....	1	ARM, IDLER w/ BEARINGS	39..	521 99 11-01.....	1	NUT 1/2-13 HEX FLG NYLOC
10..	574 60 70-01.....	1	CLUTCH, 200 FT-LB	40..	873 40 06-00	1	NUT 3/8-16 HEX WHIZLK
11..	532 19 25-07.....	1	SOLENOID	41..	539 20 02-82.....	4	NUT 3/8-16 HEX JAM NYLOC
12..	575 01 73-02.....	1	STOP, CLUTCH	42..	521 99 65-01.....	2	NUT 3/8-16 HEX FLG NYLOC
13..	583 95 57-01.....	1	EXHAUST TUBE, RT	43..	539 11 28-99.....	15	NUT 5/16-18 HEX FLG NYLOC
14..	583 95 56-01.....	1	EXHAUST TUBE, LT	44..	539 10 81-20.....	3	NUT 1/4-20 HEX THIN NYLOC
15..	539 13 16-04.....	1	MUFFLER ASM TWIN	45..	539 11 55-28.....	1	WASHER 1/2" BELLEVILLE
16..	584 82 55-01.....	1	HOSE, DRAIN	46..	819 18 22-12.....	2	WASHER 1/2 FLT
17..	539 91 27-57.....	1	KEY 1/4 SQ x 1 1/4	47..	810 03 07-00.....	1	WASHER 7/16 SLW
18..	522 59 90-01.....	1	ADAPTER	48..	810 03 06-00.....	4	WASHER 3/8 SPLT LK
19..	539 10 27-57.....	1	CABLE	49..	819 11 11-16.....	2	WASHER 5/16 SAE FLAT
20..	575 22 99-02.....	1	BRACKET, MUFFLER, BLK	50..	539 99 00-53.....	1	WASHER 1/4 INT TOOTH LK
21..	510 25 44-01.....	1	SPRING, PUMP	51..	539 11 18-97.....	1	WASHER, SPECIAL
22..	539 11 46-62.....	1	SHIELD, DUST	52..	539 10 95-62.....	1	WASHER 3/8 x 3/4
23..	510 25 45-01.....	2	SHIELD, DUST	NOT SHOWN			
24..	539 13 15-63.....	2	INSULATOR	575 01 83-01.....	1	PIGTAIL	
25..	539 10 27-59.....	1	INSULATOR	586 83 97-01.....	2	GASKET, MUFFLER KAW	
26..	539 10 13-63.....	1	CLAMP	-----	1	ENGINE, Kawasaki FR730V 24 HP For engine service and replacement parts, see a Kawasaki dealer	
27..	874 49 06-32.....	1	BOLT 3/8-16 x 2 HEX FLG HD				
28..	874 49 05-12.....	11	BOLT 5/16-18 x 3/4 HEX FLG HD				
29..	874 78 05-16.....	2	BOLT 5/16-18 x 1				
30..	581 33 28-02.....	1	BOLT 7/16-20 x 2 1/2				

STEERING

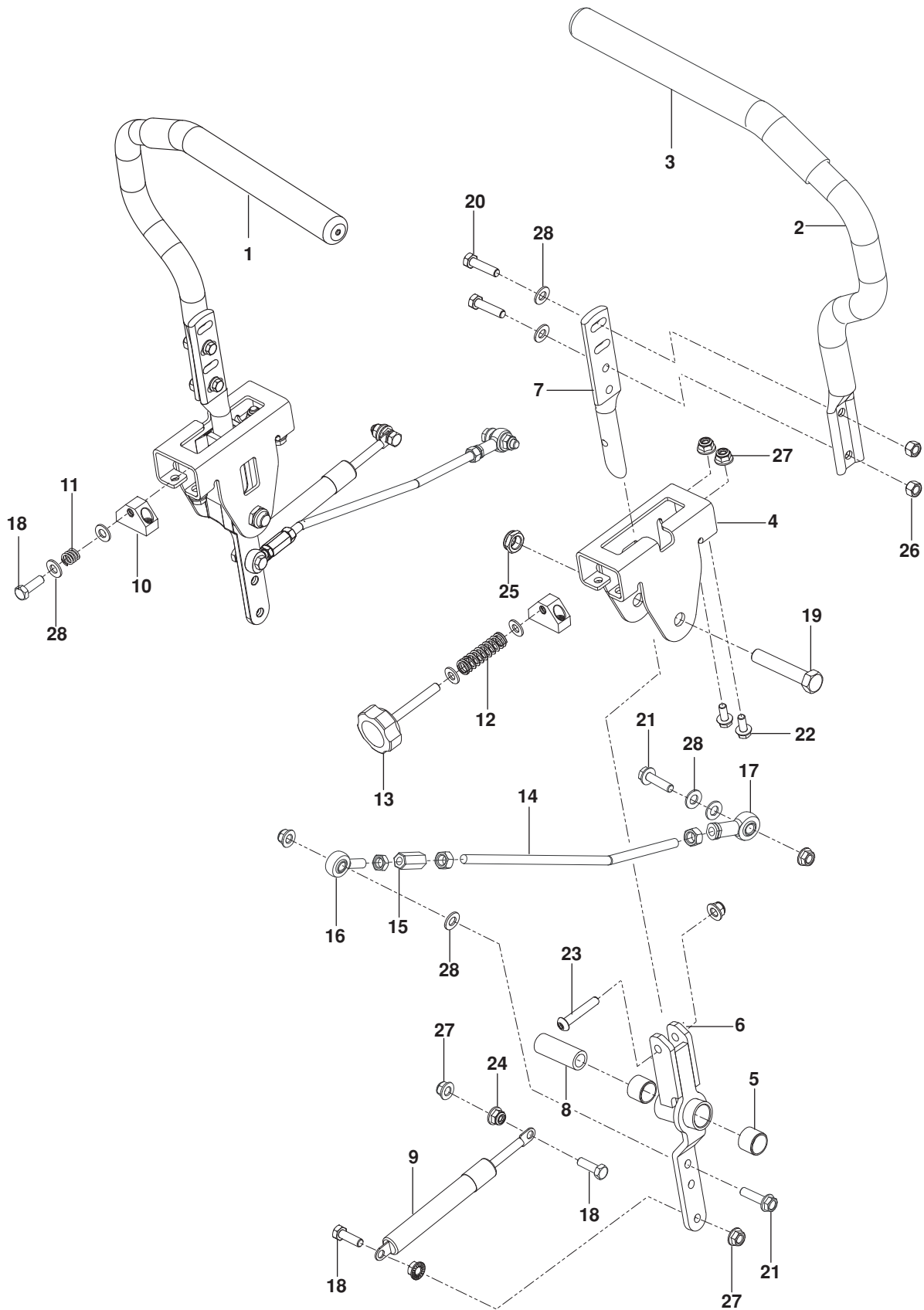

STEERING

ITEM	PART NO.	QTY.	DESCRIPTION	ITEM	PART NO.	QTY.	DESCRIPTION
1..	539 13 20-09.....	1	LEVER w/ GRIP RT	15..	539 11 66-89.....	2	COUPLER, ROD END
2..	539 13 20-10.....	1	LEVER w/ GRIP LT	16..	539 11 66-90.....	2	ROD END LT
3..	539 13 08-94.....	2	GRIP, FOAM	17..	539 11 57-29.....	2	ROD END RT
4..	586 73 72-02.....	2	BRACKET, CONTROL	18..	874 78 05-20.....	5	BOLT $\frac{5}{16}$ -18 x $1\frac{1}{4}$ HEX HD
5..	532 43 82-82.....	4	BUSHING	19..	874 78 08 44.....	2	BOLT $\frac{1}{2}$ -13 x $2\frac{3}{4}$ HEX HD
6..	587 18 77 01.....	2	LEVER, CONTROL	20..	539 97 69-35.....	4	BOLT $\frac{5}{16}$ -18 x $1\frac{1}{2}$ HEX HD
7..	577 42 00-01.....	2	LEVER, HANDLE	21..	525 54 40-01.....	4	BOLT $\frac{5}{16}$ -18 x $1\frac{1}{4}$ TPBLT
8..	584 92 72-01.....	2	SPACER, PIVOT CONTROL	22..	874 49 05 12.....	8	BOLT $\frac{5}{16}$ -18 X $\frac{3}{4}$ HEX FLG HD
9..	539 10 27-20.....	2	DAMPENER	23..	576 85 04-02.....	2	SCREW $\frac{5}{16}$ -18 X $1\frac{3}{4}$ BTN HD
10..	581 43 75-01	2	BLOCK, TRACKING	24..	539 99 05-85.....	4	NUT $\frac{5}{16}$ -18 HEX WHIZLK
11..	539 10 28-45.....	1	SPRING	25..	539 10 80-10.....	2	NUT $\frac{1}{2}$ -13 HEX JAM NYL GR2
12..	576 85 03-01.....	1	SPRING	26..	539 99 07-17.....	6	NUT $\frac{5}{16}$ -18 HEX NYLOC
13..	539 13 17-99.....	1	KNOB	27..	539 11 28-99.....	10	NUT $\frac{5}{16}$ -18 HEX FLG NYLOC
14..	574 81 14-01.....	2	ROD, MOTION CONTROL	28..	819 11 11-16.....	12	WASHER $\frac{5}{16}$ SAE FLT

IGNITION

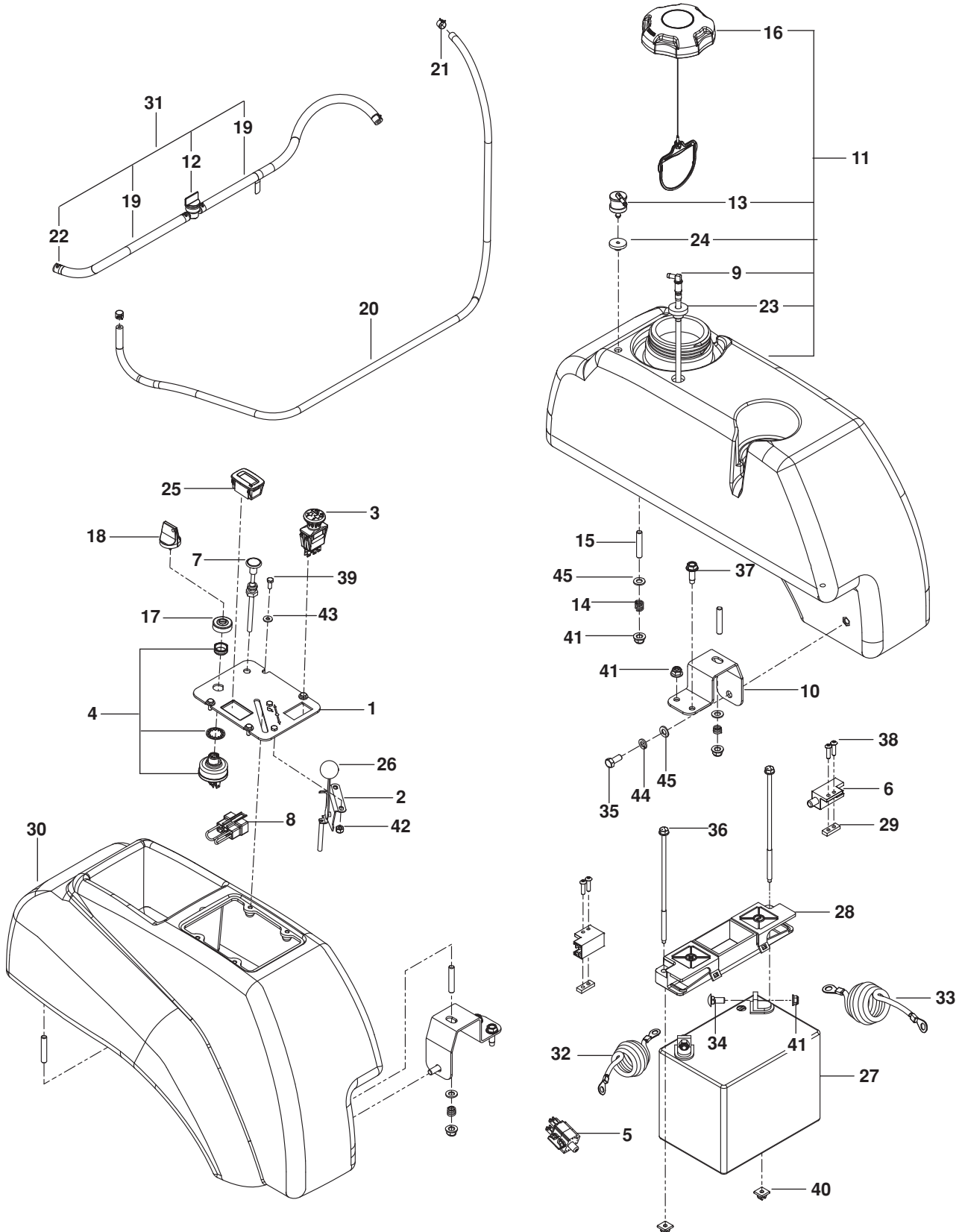

IGNITION

ITEM	PART NO.	QTY.	DESCRIPTION	ITEM	PART NO.	QTY.	DESCRIPTION
1..	574 84 12-04.....	1	PLATE, CONSOLE, BLK	25..	586 16 18-01.....	1	METER, SERVICE
2..	539 10 27-32.....	1	CABLE, THROTTLE	26..	539 13 30-49.....	1	KNOB
3..	539 13 16-27.....	1	SWITCH, PTO 10 AMP	27..	539 10 24-36.....	1	BATTERY
4..	574 45 54-01.....	1	SWITCH, IGNITION	28..	539 10 76-28.....	1	BATTERY HOLD DOWN
5..	539 11 37-92.....	1	SWITCH, BRAKE	29..	539 10 26-78.....	2	PLATE, TAPPED
6..	532 10 95-53.....	2	SWITCH, INTERLOCK	30..	539 10 75-93.....	1	CONSOLE, RT GRY
7..	539 11 34-58.....	1	CHOKE CONTROL	31..	586 12 39-03.....	1	ASSY, FUEL LINE
8..	575 32 10-01.....	1	PLUG, TIMER	32..	539 10 49-74.....	1	CABLE, POSITIVE 31"
9..	576 46 92-01.....	1	FITTING, FUEL	33..	539 10 76-45.....	1	CABLE, NEGATIVE 32"
10..	539 13 16-71.....	2	SUPPORT, TANK, BLK	34..	539 99 03-16.....	2	BOLT ⁵ / ₁₆ -18 x ³ / ₄ RD HD SQNK
11..	585 72 23-01.....	1	TANK ASSY LT GRY	35..	874 78 05-12.....	2	BOLT ⁵ / ₁₆ -18 x ³ / ₄ HEX HD
12..	539 91 63-25.....	1	VALVE, FUEL	36..	539 10 76-32.....	2	BOLT ¹ / ₄ x 7 ¹ / ₂
13..	576 61 81-01.....	1	VALVE, FUEL CHECK	37..	817 49 05-16.....	3	SCREW ⁵ / ₁₆ -18 x 1 THD FRM
14..	539 10 28-45.....	6	SPRING	38..	574 82 27-01.....	4	SCREW #10-24 x ³ / ₄ SKT HD
15..	539 10 25-02.....	6	STUD ⁵ / ₁₆ -18	39..	539 99 04-11.....	6	SCREW #10-24 x ¹ / ₂ SLT
16..	575 01 81-01.....	1	FUEL CAP w /TETHER	40..	539 10 76-29.....	2	NUT ¹ / ₄ PUSH NYLON
17..	539 10 31-78.....	1	CAP, IGNITION SWITCH NUT	41..	539 11 28-99.....	12	NUT ⁵ / ₁₆ -18 HEX FLANGE NYL
18..	574 45 55-01.....	1	KEY, IGNITION	42..	539 976977	2	NUT #10-24 NYLOC
19..	587 04 48 10.....	2	HOSE, FUEL 10"	43..	819 07 08-18.....	4	WASHER #10
20..	587 04 45-27.....	1	HOSE ³ / ₁₆ VAPOR 27"	44..	810 03 05-00.....	2	WASHER ⁵ / ₁₆ SLW
21..	575 43 65-01.....	2	CLAMP, HOSE	45..	819 11 11-16.....	8	WASHER ⁵ / ₁₆ SAE
22..	539 91 22-22.....	4	CLAMP, HOSE	NOT SHOWN			
23..	539 10 52-45.....	1	GROMMET, RUBBER	585 99 97-01.....	1	HARNESS, MAIN	
24..	576 61 82-01.....	1	GROMMET, CHECK VALVE				

PARK BRAKE

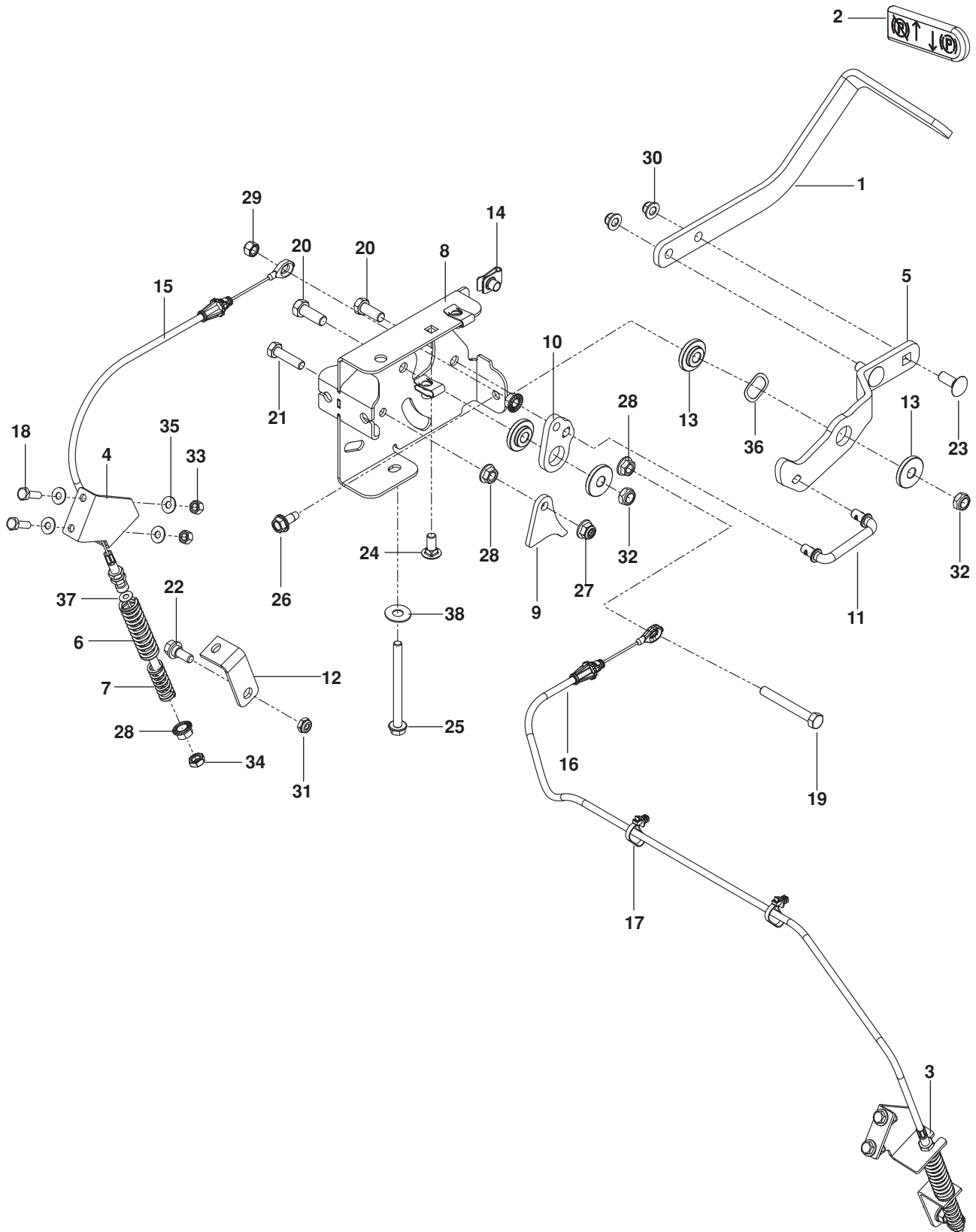

PARK BRAKE

ITEM	PART NO.	QTY.	DESCRIPTION	ITEM	PART NO.	QTY.	DESCRIPTION
1..	539 13 21-51.....	1	ARM, BRAKE	21..	539 99 02-09.....	1	BOLT $\frac{5}{16}$ -18 x 1 HEX HD
2..	539 10 50-36.....	1	GRIP, BRAKE HANDLE	22..	539 11 03-03.....	2	BOLT $\frac{5}{16}$ SHOULDER
3..	575 22 96-02.....	1	BRACKET, RT BLK	23..	539 99 06-45.....	2	BOLT $\frac{3}{8}$ -16 x 1 RD HD SQNK
4..	575 22 97-02.....	1	BRACKET, LT BLK	24..	539 99 03-16.....	1	BOLT $\frac{5}{16}$ -18 x $\frac{3}{4}$ RD HD SQNK
5..	539 13 24-23.....	1	LEVER, BRAKE	25..	539 13 17-80.....	1	BOLT $\frac{5}{16}$ -18 x $3\frac{3}{4}$ HEX FLG HD
6..	575 23 02-01.....	2	SPRING, RETURN	26..	539 10 74-75.....	1	BOLT $\frac{5}{16}$ -18 x $\frac{3}{4}$ THD FRM
7..	575 23 03-01.....	2	SPRING, ENGAGEMENT	27..	539 11 28-99.....	4	NUT $\frac{5}{16}$ -18 FLANGE NYLOC
8..	539 13 21-58.....	1	MOUNT, BRAKE	28..	539 99 05-85.....	5	NUT $\frac{5}{16}$ -18 HEX WHIZLK
9..	539 13 21-54.....	1	ACTUATOR, SWITCH	29..	539 99 07-17.....	1	NUT $\frac{5}{16}$ -18 HEX NYLOC
10..	539 13 21-53.....	1	BELLCRANK, BRAKE	30..	521 99 65-01.....	2	NUT $\frac{3}{8}$ -16 HEX FLG NYLOC
11..	539 13 24-24.....	1	LINKAGE, BRAKE	31..	539 11 56-17.....	2	NUT $\frac{5}{16}$ HEX NYLOC
12..	575 22 98-02.....	2	BRACKET, BRAKE	32..	539 20 02-82.....	2	NUT $\frac{3}{8}$ -16 HEX JAM NYLOC
13..	539 13 21-61.....	4	BUSHING, BRAKE	33..	539 97 69-78.....	4	NUT $\frac{1}{4}$ -20 HEX NYLOC
14..	539 10 47-63.....	3	RETAINER, U TYPE $\frac{5}{16}$ -18	34..	539 10 78-97.....	2	NUT $\frac{5}{16}$ -18 HEX JAM
15..	539 13 21-73.....	1	CABLE, BRAKE SHORT	35..	539 99 00-55.....	8	WASHER $\frac{1}{4}$ SAE FLT
16..	539 13 21-74.....	2	CABLE, BRAKE LONG	36..	539 13 30-07.....	1	WASHER .825 WAVE
17..	505 28 00-01.....	2	TIE w/ CLIP	37..	539 99 01-22.....	2	WASHER $\frac{3}{8}$ SAE
18..	539 99 06-43.....	4	BOLT $\frac{1}{4}$ -20 x $\frac{7}{8}$ HEX HD	38..	539 10 95-54.....	1	WASHER $\frac{1}{2}$ FLAT
19..	539 10 83-96.....	1	BOLT $\frac{5}{16}$ -18 x $2\frac{1}{2}$ HEX HD				
20..	539 99 05-63.....	2	BOLT $\frac{3}{8}$ -16 x 1 HEX HD				

HYDRAULIC PUMP-MOTOR

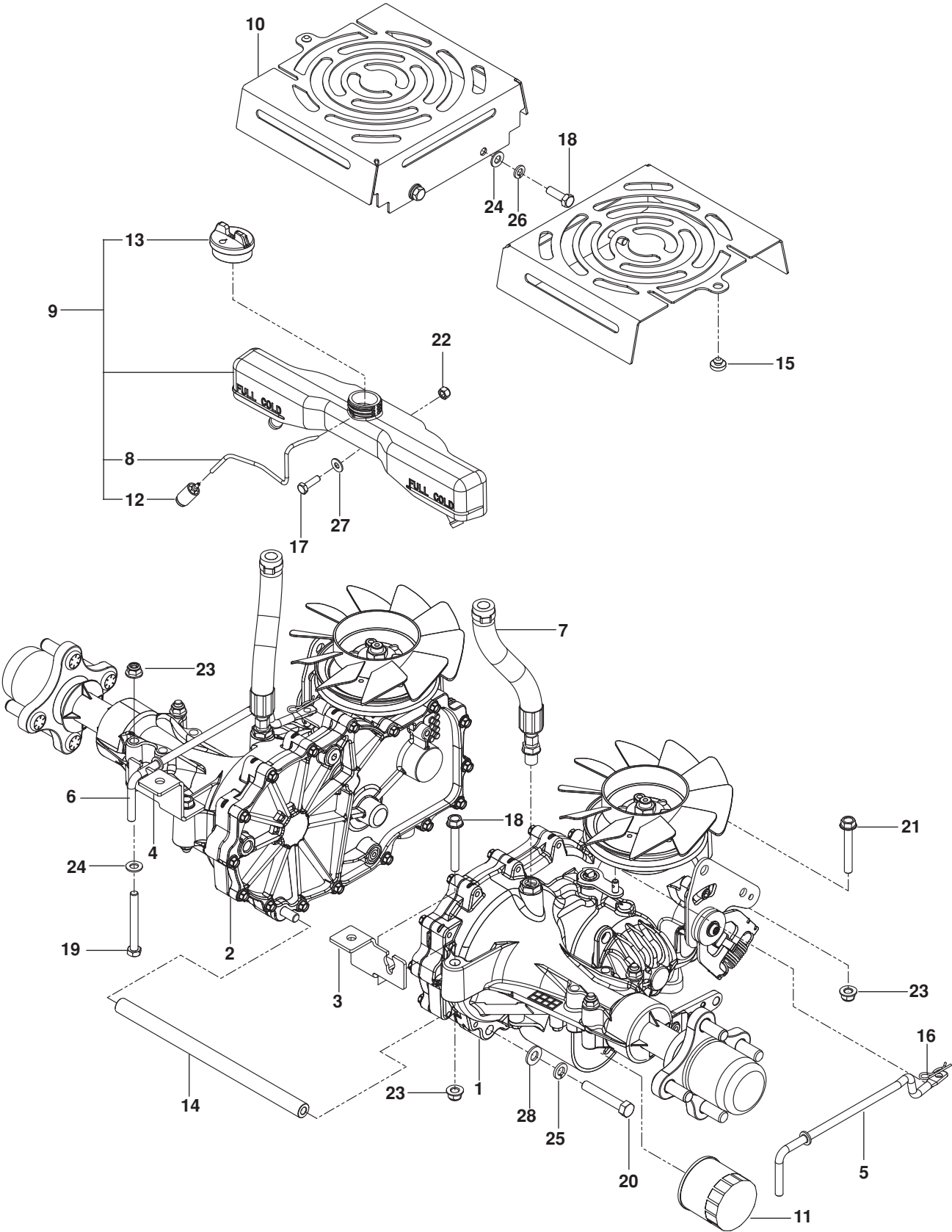

HYDRAULIC PUMP-MOTOR

ITEM	PART NO.	QTY.	DESCRIPTION	ITEM	PART NO.	QTY.	DESCRIPTION
1..	577 22 77-02.....	1	TRANS, ZT-3100, LT	15..	539 10 25-87.....	2	GROMMET, BUMPER
2..	577 22 77-01.....	1	TRANS, ZT-3100, RT	16..	539 97 69-88.....	2	HAIRPIN COTTER
3..	575 01 71-02.....	1	BRACKET, TRANS, LT	17..	539 99 06-43.....	1	BOLT 1/4-20 x 7/8 HEX HD
4..	575 01 70-02.....	1	BRACKET, TRANS, RT	18..	539 99 02-09.....	4	BOLT 5/16-18 x 1 HEX HD
5..	539 13 16-16.....	1	LINKAGE, BYPASS LT	19..	539 10 17-21.....	4	BOLT 5/16-18 x 2 3/4 HEX HD
6..	539 13 16-18.....	1	LINKAGE, BYPASS RT	20..	539 10 85-51.....	2	BOLT 3/8-16 x 2 1/2 HEX HD GR8
7..	574 89 21-01.....	2	HOSE, EXPANSION	21..	574 23 38-01.....	4	BOLT 5/16-18 x 2 1/4 HEX FLG HD
8..	586 06 75-01.....	1	HOSE, FUEL	22..	539 97 69-78.....	1	NUT 1/4-20 HEX NYLOC
9..	585 31 82-01.....	1	TANK, EXPANSION	23..	539 11 28-99.....	8	NUT 5/16-18 HEX FLG NYLOC
10..	584 99 42-02.....	2	COVER, FAN	24..	819 11 11-16.....	8	WASHER 5/16 SAE FLT
11..	539 11 34-66.....	2	FILTER, HYDRO	25..	539 99 01-18.....	2	WASHER 3/8 SPLT LK
12..	530 09 56-46.....	1	FILTER	26..	539 99 01-87.....	4	WASHER 5/16 SLW
13..	586 07 27-01.....	1	CAP, TANK	27..	539 99 00-55.....	1	WASHER 1/4 SAE FLT
14..	574 86 85-01.....	1	TUBE 10 3/8" SPACER	28..	539 99 01-22.....	2	WASHER 3/8 SAE FLT

WHEELS

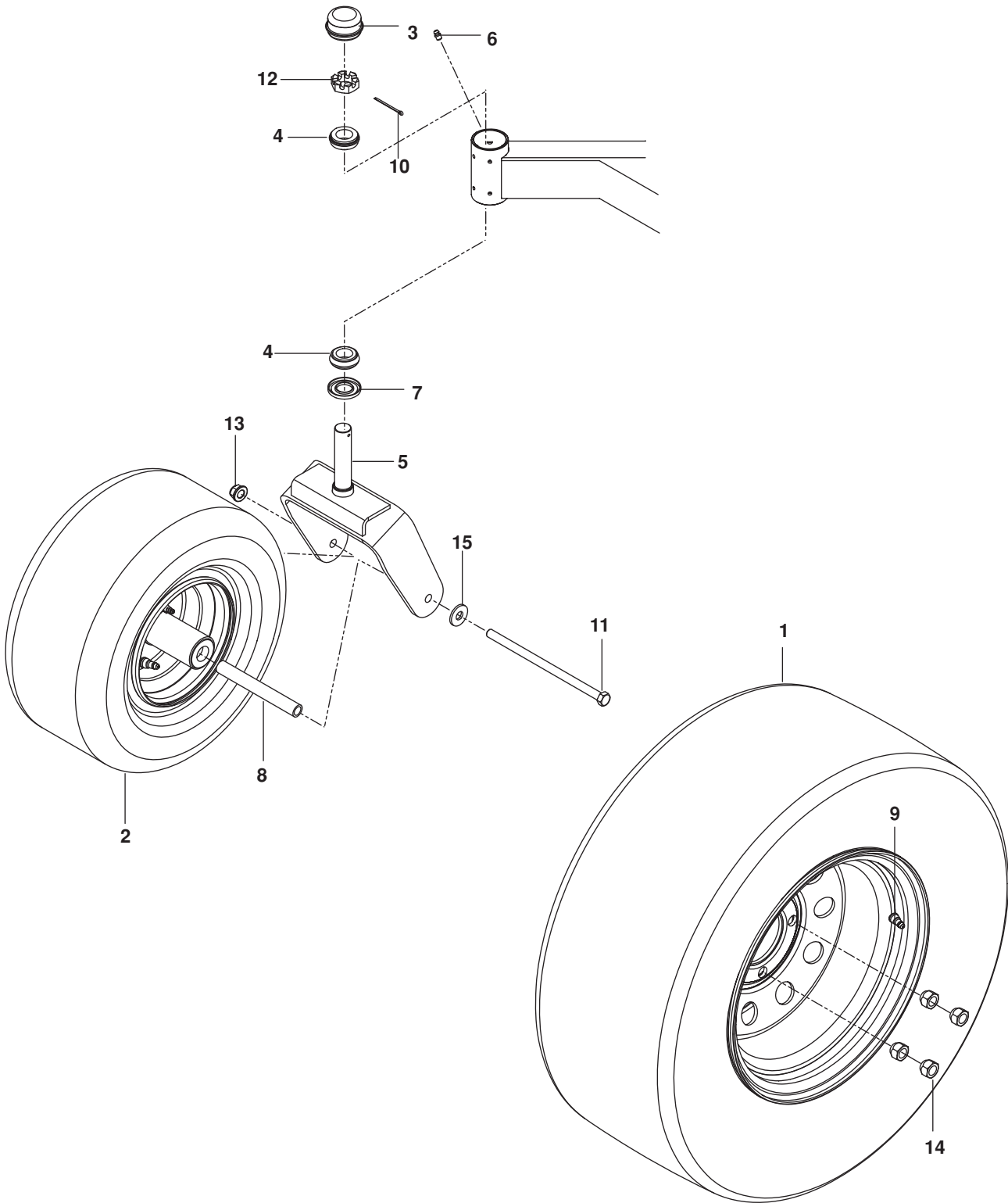

WHEELS

ITEM	PART NO.	QTY.	DESCRIPTION	ITEM	PART NO.	QTY.	DESCRIPTION
1..	580 74 70-01.....	2.....	WHEEL ASSY 22 x 10-10	9..	539 91 22-34.....	2.....	AIR VALVE
2..	581 19 95-01.....	2.....	WHEEL ASSY 13 x 6.5	10..	539 10 28-89.....	2.....	COTTER PIN 1/8 x 2
3..	539 10 25-35.....	2.....	CAP, GREASE	11..	539 10 55-17.....	2.....	BOLT 1/2-13 x 9 1/2 HEX HD
4..	539 10 25-43.....	4.....	BEARING, ROLLER TAPERED	12..	539 10 28-52.....	2.....	NUT 1"-14 SLOTTED JAM
5..	575 32 92-02.....	2.....	YOKE, CASTER, ORG	13..	521 99 11-01	2.....	NUT 1/2-13 HEX FLG NYLOC
6..	539 10 14-74.....	2.....	ZERK	14..	539 10 11-73.....	8.....	NUT 1/2-20 LUG
7..	539 10 28-51.....	2.....	SEAL	15..	539 10 95-54.....	2.....	WASHER 1/2 FLT
8..	575 33 49-01.....	2.....	SPACER, PIVOT				

MOWER LIFT / DECK LIFT

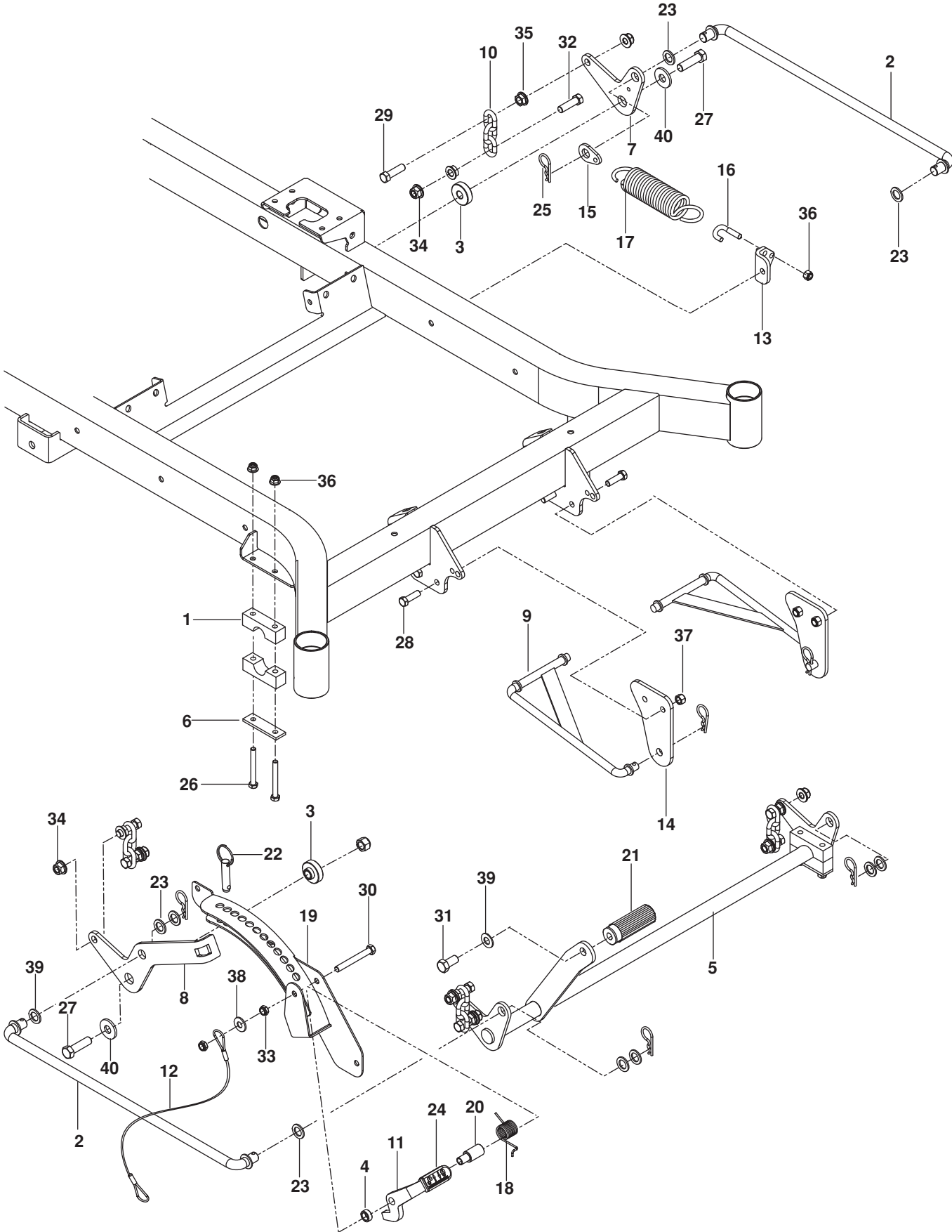

MOWER LIFT / DECK LIFT

ITEM	PART NO.	QTY.	DESCRIPTION	ITEM	PART NO.	QTY.	DESCRIPTION
1..	539 10 48-08.....	4.....	PILLOW BLOCK	21..	510 40 83-01.....	1.....	PEDAL, FOOT
2..	539 11 08-08.....	2.....	LINK, DECK LIFT	22..	539 13 21-82.....	1.....	PIN ½ x 1½ DETENT RING
3..	586 70 17-01.....	2.....	SPACER, IDLER	23..	539 99 10-43.....	10.....	BUSHING .625
4..	539 13 18-61.....	1.....	SPACER	24..	539 13 28-51.....	1.....	GRIP
5..	581 21 52-02.....	1.....	SHAFT, FRONT LIFT BLK	25..	539 11 55-01.....	6.....	PIN, COTTER 1¾
6..	539 10 48-07.....	2.....	REINFORCEMENT BAR	26..	539 10 17-21.....	4.....	BOLT 5/16-18 x 2¾ HEX HD
7..	539 13 18-97.....	1.....	BELLCRANK, RR, LIFT BLK	27..	539 10 81-81.....	2.....	BOLT ½-13 x 1¾ GR 8 HEX HD
8..	539 13 18-53.....	1.....	BELLCRANK, RR, RT BLK	28..	539 97 69-41.....	4.....	BOLT 3/8-16 X 1¼ HEX HD
9..	539 11 22-23.....	2.....	LINKAGE, STRUT	29..	539 10 11-75.....	4.....	BOLT 7/16-14 x 1½ HEX HD
10..	539 10 96-93.....	4.....	LIFT CHAIN-3 LINK	30..	874 78 06-48.....	1.....	BOLT 3/8-16 x 3 HEX HD
11..	539 13 15-66.....	1.....	LATCH, TRANSPORT	31..	539 99 06-46.....	1.....	BOLT ½-13 x 1 HEX HD
12..	539 10 50-59.....	1.....	LANYARD	32..	539 10 80-73.....	4.....	BOLT 7/16-14 x 1¾ HEX HD
13..	539 13 17-91.....	1.....	MOUNT, SPRING	33..	539 20 02-82.....	2.....	NUT 3/8-16 HEX JAM NYLOC
14..	539 13 20-17.....	2.....	MOUNT, STRUT	34..	539 13 20-19.....	8.....	NUT 7/16-14 HEX WHIZ LK
15..	539 13 17-92.....	1.....	TAB, SPRING	35..	539 10 25-82.....	8.....	NUT 7/16-14 HEX WHIZ LK
16..	539 11 28-96.....	1.....	J-BOLT	36..	539 11 28-99.....	5.....	NUT 5/16-18 HEX FLG NYLOC
17..	539 10 26-42.....	1.....	SPRING	37..	539 97 69-79.....	4.....	NUT 3/8-16 HEX NYLOC
18..	539 13 27-34.....	1.....	SPRING, TORSION	38..	819 14 14-16.....	1.....	WASHER 3/8 FLT
19..	539 13 18-50.....	1.....	HEIGHT ADJUST, DECK	39..	539 10 28-43.....	1.....	WASHER 7/16 SPRING
20..	539 13 18-60.....	1.....	PIVOT LATCH, TRANSPORT	40..	539 10 95-54.....	2.....	WASHER ½ FLT

MOWER DECK / CUTTING DECK

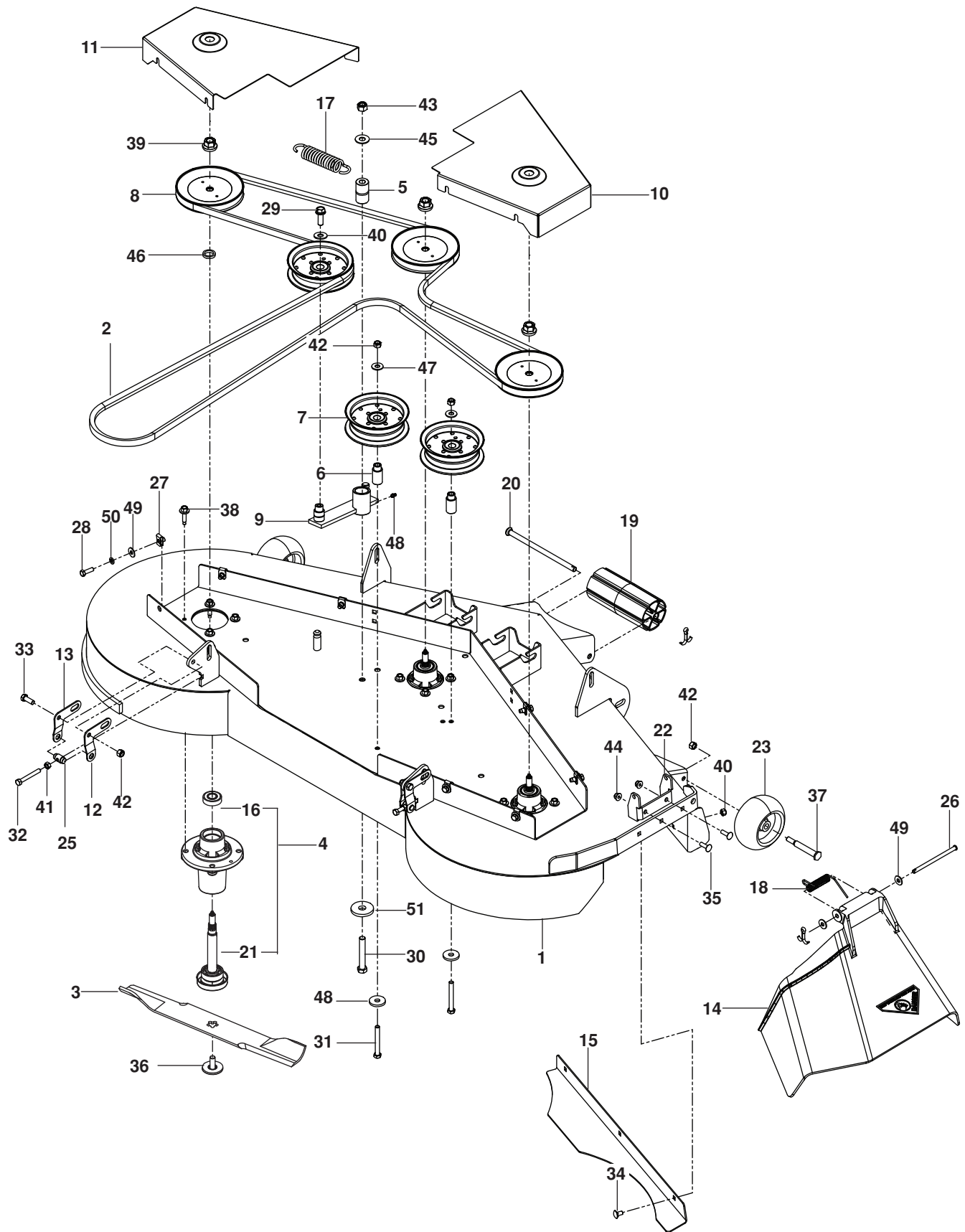

MOWER DECK / CUTTING DECK

ITEM	PART NO.	QTY.	DESCRIPTION	ITEM	PART NO.	QTY.	DESCRIPTION
1..	581 50 54-01.....	1	DECK w/ SAFETY DECALS	27..	539 10 47-63.....	8	RETAINER, U TYPE $\frac{5}{16}$ -18
2..	539 10 43-35.....	1	BELT, DECK	28..	539 97 69-34.....	8	BOLT $\frac{5}{16}$ -18 x $\frac{3}{4}$ HEX HD
3..	539 113312.....	3	BLADE, 21"	29..	539 99 05-82.....	1	BOLT $\frac{3}{8}$ -16 x 1 HEX WHIZLK
4..	539 13 18-98.....	3	HOUSING ASSEMBLY	30..	539 10 34-33.....	1	BOLT $\frac{1}{2}$ -13 x $3\frac{1}{4}$ HEX HD
5..	539 10 34-27.....	1	BUSHING, PIVOT	31..	874 78 06-48.....	2	BOLT $\frac{3}{8}$ -16 x 3 HEX HD
6..	539 11 21-69.....	2	BUSHING, IDLER	32..	539 10 83-96.....	2	BOLT $\frac{5}{16}$ -18 x $2\frac{1}{2}$ HEX TPBLT
7..	539 13 27-28.....	3	PULLEY, IDLER	33..	539 99 05-63.....	2	BOLT $\frac{3}{8}$ -16 x 1 HEX HD
8..	539 11 33-00.....	3	PULLEY	34..	539 99 07-99.....	3	BOLT $\frac{5}{16}$ -18 x $\frac{5}{8}$ RD HD SQNK
9..	539 11 21-98.....	1	ARM, IDLER	35..	872 11 05-08.....	2	BOLT $\frac{5}{16}$ -18 x 1 RD HD SQNK
10..	539 11 33-21.....	1	BELT SHIELD, RT ORG	36..	532 19 30-03.....	3	BOLT $\frac{7}{16}$ BLADE
11..	539 11 33-24.....	1	BELT SHIELD, LT ORG	37..	532 13 76-44.....	2	BOLT, SHOULDER
12..	584 85 94-02.....	2	PITCH ADJUST, RT	38..	539 10 76-30.....	12	SCREW, WSH HD
13..	584 85 94-04.....	2	PITCH ADJUST, LT	39..	532 40 02-34.....	3	NUT $\frac{9}{16}$ TOP CENTER LOCK
14..	539 11 07-34.....	1	CHUTE, DISCHARGE	40..	539 99 07-17.....	3	NUT $\frac{5}{16}$ -18 HEX NYLOC
15..	539 11 33-17.....	1	PLATE, CONFINEMENT	41..	539 99 01-96.....	2	NUT $\frac{5}{16}$ -18 HEX
16..	532 11 04-85.....	3	BEARING, BALL	42..	539 97 69-79.....	6	NUT $\frac{3}{8}$ -16 HEX NYLOC
17..	539 10 32-56.....	1	SPRING	43..	539 10 13-31.....	1	NUT $\frac{1}{2}$ HEX NYLOC
18..	539 11 07-35.....	1	SPRING, TORSION	44..	539 11 28-99.....	2	NUT $\frac{5}{16}$ -18 HEX FLG NYLOC
19..	532 17 60-66.....	1	ROLLER, NOSE	45..	539 99 05-50.....	1	WASHER $\frac{1}{2}$ STD FLT
20..	532 17 91-27.....	1	ROD, ROLLER, NOSE	46..	532 18 76-90.....	3	WASHER-SPACER
21..	532 18 72-91.....	3	SHAFT	47..	539 99 05-17.....	2	WASHER $\frac{3}{8}$ FLAT STD
22..	581 60 60-02.....	1	BRACKET ORG	48..	539 10 65-04.....	2	WASHER, HEAVY
23..	532 13 39-57.....	2	WHEEL, GAUGE	49..	539 99 06-92.....	10	WASHER $\frac{5}{16}$ STD FLT
24..	539 97 69-98.....	1	ZERK	50..	539 10 96-00.....	8	WASHER $\frac{5}{16}$ SPRING
25..	539 13 18-59.....	2	TRUNION, PITCH	51..	539 10 22-43.....	1	WASHER, SUPPORT
26..	539 11 07-36.....	1	PIN $\frac{5}{16}$ CLEVIS				

SEAT

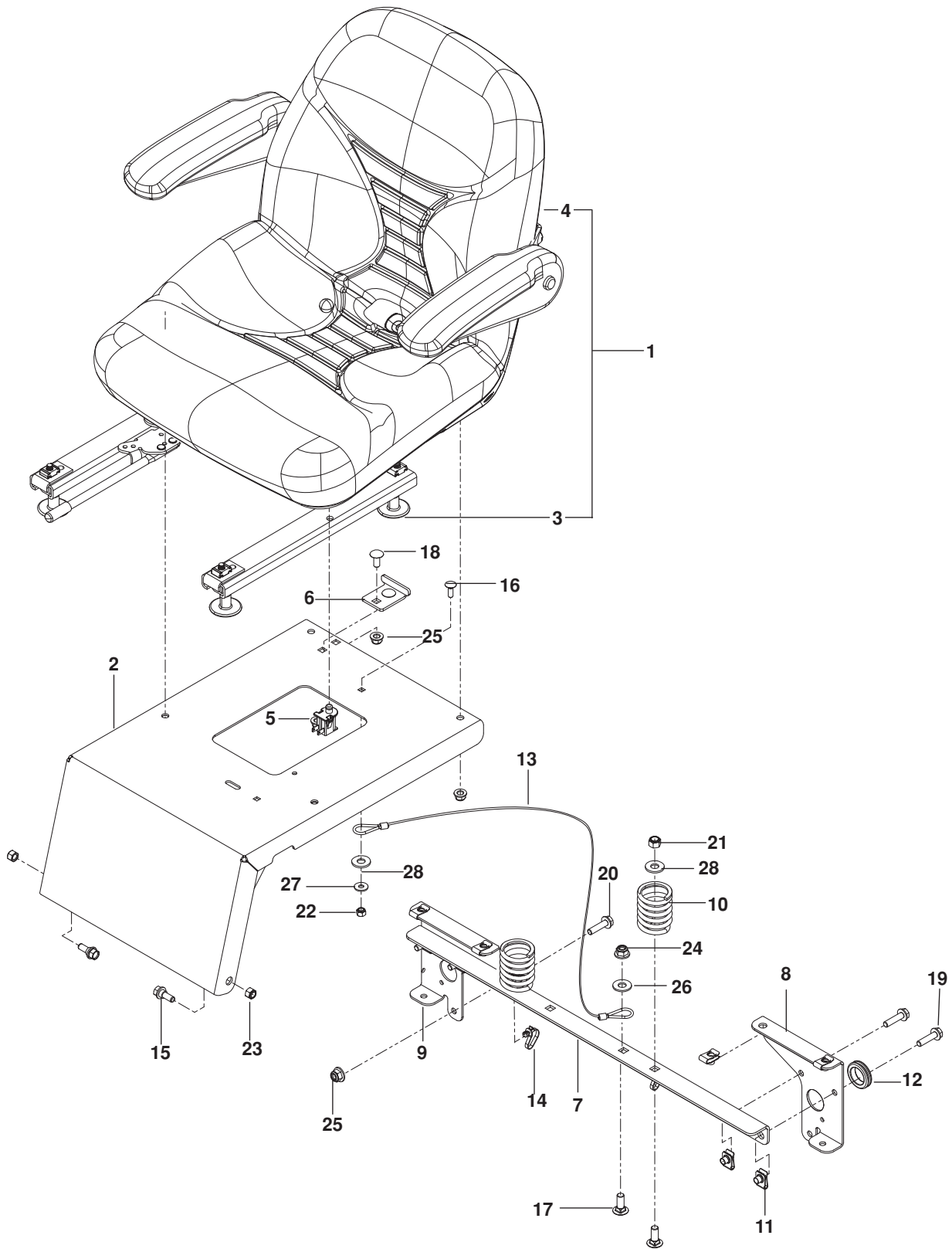

SEAT

ITEM	PART NO.	QTY.	DESCRIPTION	ITEM	PART NO.	QTY.	DESCRIPTION
1..	539 13 08-73.....	1	SEAT ASSY	14..	505 28 00-01.....	2	TIE WRAP w/ CLIP
2..	575 60 86-01.....	1	MOUNT, SEAT w/ DECAL	15..	539 13 08-96.....	2	BOLT $\frac{5}{16}$ -18 SHOULDER
3..	539 11 20-37.....	1	RAIL SET, SEAT	16..	539 99 00-74.....	1	BOLT $\frac{1}{4}$ -40 x $\frac{3}{4}$ RD HD SQNK
4..	539 11 20-36.....	1	ARM REST, LT	17..	539 99 06-45.....	3	BOLT $\frac{3}{8}$ -16 x 1 RD HD SQNK
	539 11 20-35.....	1	ARM REST, RT	18..	872 05 05-06.....	2	BOLT $\frac{5}{16}$ -18 x $\frac{3}{4}$ RD HD SQNK
5..	532 42 10-62.....	1	SWITCH, SEAT	19..	525 54 40-01.....	4	BOLT $\frac{5}{16}$ -18 x $1\frac{1}{4}$ HEX FLG HD
6..	539 13 07-93.....	1	DECK STOP	20..	525 46 47-01.....	2	BOLT $\frac{5}{16}$ -18 x $\frac{3}{4}$ HEX FLG HD
7..	539 13 16-56.....	1	SUPPORT, SEAT	21..	539 97 69-79.....	2	NUT $\frac{3}{8}$ -16 HEX NYLOC
8..	584 99 02-02.....	1	SUPPORT, LT	22..	539 97 69-78.....	1	NUT $\frac{1}{4}$ -20 HEX NYLOC
9..	584 99 01-02.....	1	SUPPORT, RT	23..	539 99 07-17.....	2	NUT $\frac{5}{16}$ -18 HEX NYLOC
10..	532 12 41-81.....	2	SPRING, SEAT	24..	521 99 65-01.....	1	NUT $\frac{3}{8}$ -16 HEX FLG NYLOC
11..	539 10 47-63.....	8	RETAINER, U TYPE	25..	539 11 28-99.....	8	NUT $\frac{5}{16}$ -18 HEX FLG NYLOC
12..	539 10 59-74.....	1	GROMMET RUBBER	26..	539 99 05-17.....	4	WASHER $\frac{3}{8}$ FLAT STD
13..	539 10 32-47.....	1	LANYARD, SEAT	27..	539 99 05-98.....	1	WASHER $\frac{1}{4}$ FLAT

DECALS

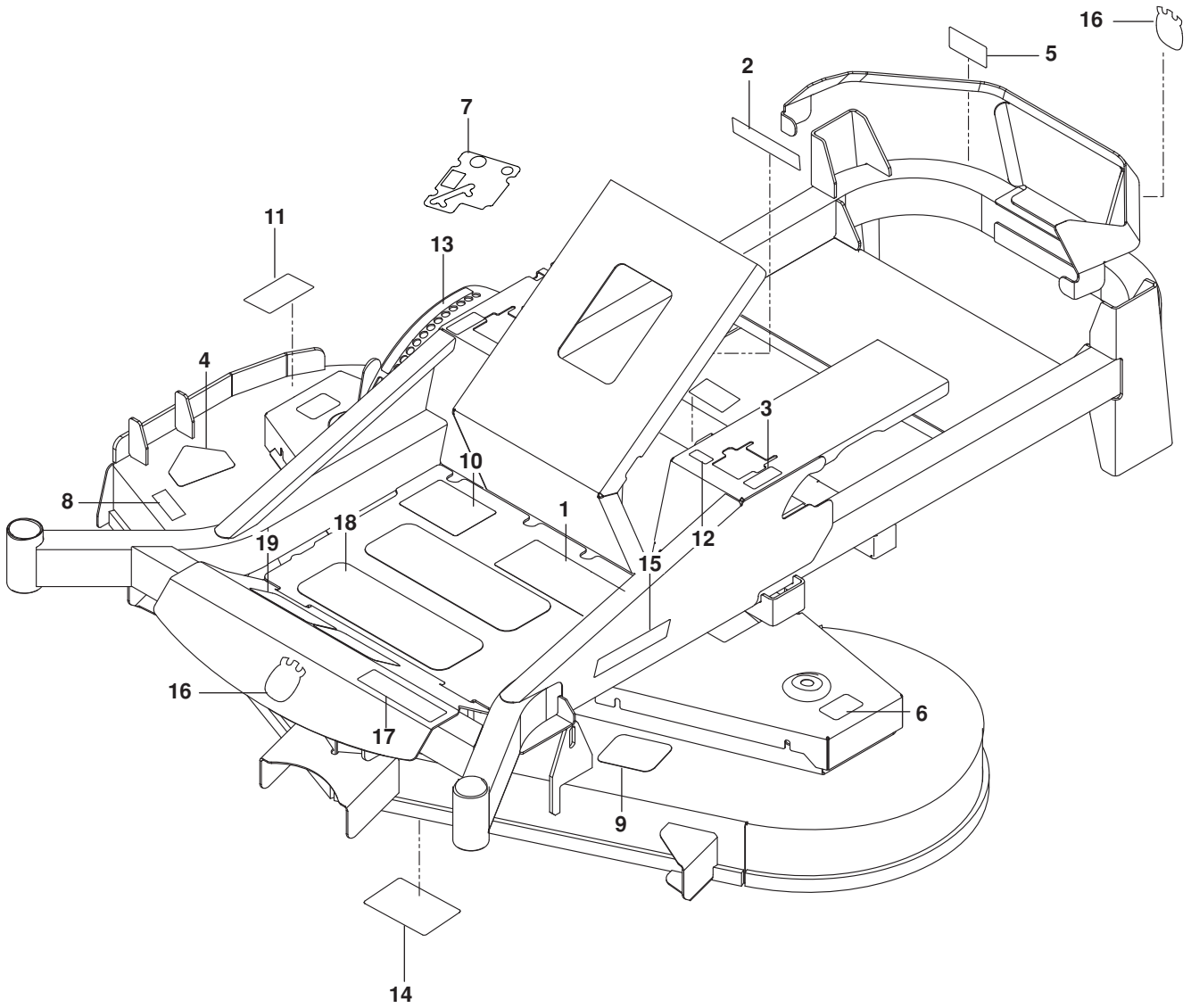

DECALS

ITEM	PART NO.	QTY.	DESCRIPTION	ITEM	PART NO.	QTY.	DESCRIPTION
1..	539 10 79-59 1DECAL, WARNING	11..	581 72 44-01 1DECAL, DEFLECTOR
2..	539 10 57-45 1DECAL, BATTERY WARNING	12..	539 11 09-74 2DECAL, TRACKING
3..	539 10 33-33 2DECAL, MOTION CONTROL	13..	539 13 20-39 1DECAL, HEIGHT ADJUST
4..	584 90 46-01 1DECAL, BLADE WARNING	14..	539 13 21-87 1DECAL, SERVICE
5..	539 10 57-44 1DECAL, DANGER BLT DRIVE	15..	532 42 91-96 2DECAL, HUSQVARNA
6..	581 72 43-01 2DECAL, NO STEP	16..	532 42 86-76 2DECAL, CROWN H
7..	574 84 11-03 1DECAL, CONSOLE	17..	585 65 90-01 1DECAL, MZ61
8..	539 10 57-46 1DECAL, SEVERING	18..	539 97 77-78 2PAD, ABRASIVE LG
9..	539 11 26-20 1DECAL, BELT ROUTING	19..	539 12 13-22 2PAD, ABRASIVE SM
10..	586 34 25-01 1DECAL, START				

ACCESSORIES

Blower

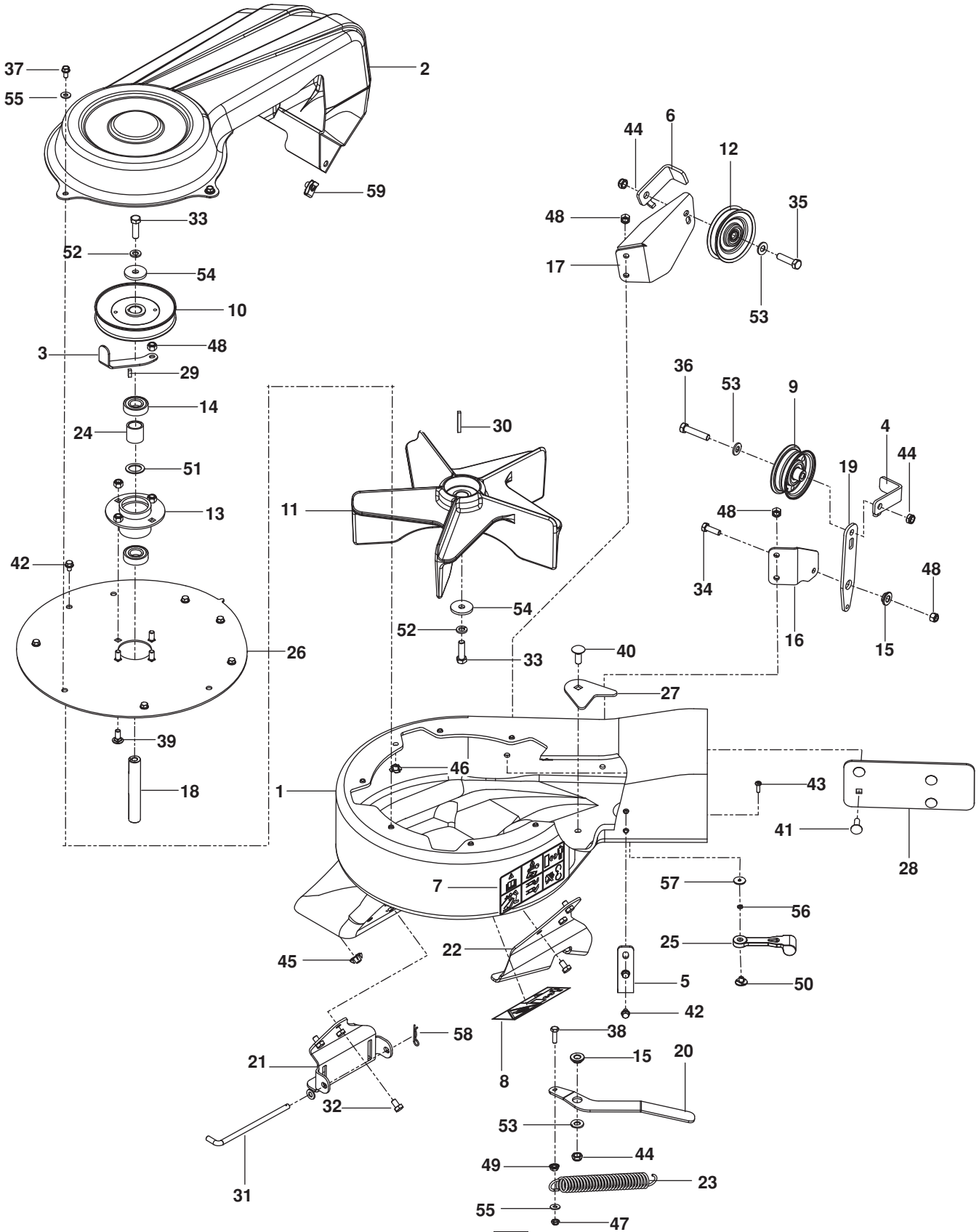

ACCESSORIES

ITEM	PART NO.	QTY.	DESCRIPTION	ITEM	PART NO.	QTY.	DESCRIPTION
1..	539 13 03-44.....	1	HOUSING w/DECALS	31..	539 13 03-17.....	1	PIN
2..	539 13 02-93.....	1	COVER, BELT	32..	874 78 05-08.....	6	BOLT $\frac{5}{16}$ -18 x $\frac{1}{2}$
3..	539 13 10-85.....	1	KEEPER, BELT OUTER	33..	532 85 08-57.....	2	BOLT $\frac{3}{8}$ -24 x $1\frac{1}{4}$ GR 8
4..	579 13 76-02.....	2	KEEPER, BELT REAR	34..	874 78 05-16.....	1	BOLT $\frac{5}{16}$ -18 x 1
5..	539 13 03-46.....	1	KEEPER	35..	874 78 06-24.....	1	BOLT $\frac{3}{8}$ -16 x $1\frac{1}{2}$
6..	579 13 77-02.....	1	KEEPER	36..	539 97 69-49.....	1	BOLT $\frac{3}{8}$ -16 x $1\frac{3}{4}$
7..	539 10 57-85.....	1	DECAL, WARNING	37..	817 49 04-08.....	3	BOLT $\frac{1}{4}$ -20 x $\frac{1}{2}$
8..	539 10 67-41.....	1	DECAL, SEVERING	38..	874 78 04-14.....	1	BOLT $\frac{1}{4}$ -20 x $\frac{7}{8}$
9..	579 15 08-02.....	1	PULLEY, IDLER	39..	872 14 05-06.....	4	BOLT $\frac{5}{16}$ -18 x $\frac{3}{4}$ RDHD SQNK
10..	539 13 03-24.....	1	PULLEY	40..	872 14 06-08.....	1	BOLT $\frac{3}{8}$ -16 x 1 RDHD SQNK
11..	539 13 02-92.....	1	IMPELLER	41..	872 14 05-08.....	4	BOLT $\frac{5}{16}$ -18 x 1 RDHD SQNK
12..	539 11 36-83.....	1	V-IDLER	42..	539 99 03-02.....	8	SCREW $\frac{1}{4}$ x $\frac{3}{8}$ THD FRM
13..	539 13 02-95.....	1	HUB, BEARING	43..	871 08 10-10.....	1	SCREW #10-24 x $\frac{5}{8}$
14..	539 13 02-96.....	2	BEARING	44..	539 20 02-82.....	3	NUT $\frac{3}{8}$ -16 HEX JAM NYLOC
15..	539 13 03-01.....	2	BUSHING	45..	539 13 03-13.....	6	NUT $\frac{5}{16}$ -18 TEE
16..	579 13 74-02.....	1	MOUNT, IDLER, UPPER	46..	539 13 03-14.....	11	NUT $\frac{1}{4}$ -20 TEE
17..	579 13 75-02.....	1	MOUNT, IDLER, LOWER	47..	539 10 81-20.....	1	NUT $\frac{1}{4}$ -20 HEX NYLOC
18..	539 13 03-16.....	1	SHAFT, IMPELLER	48..	873 80 05-00.....	9	NUT $\frac{5}{16}$ -18 HEX NYLOC
19..	579 13 73-02.....	1	ARM, IDLER	49..	532 43 81-30.....	1	NUT $\frac{1}{4}$ -20 HEX FLANGE
20..	539 13 03-38.....	1	ARM, TENSION	50..	539 10 80-89.....	1	WELD NUT, PLATED
21..	539 13 03-39.....	1	BRACKET, MOUNT, FRONT	51..	539 91 09-35.....	1	WASHER
22..	539 13 03-40.....	1	BRACKET, MOUNT, REAR	52..	810 03 06-00.....	2	WASHER $\frac{3}{8}$ SPLT LOCK
23..	539 10 19-77.....	1	SPRING, TRACTION	53..	819 13 13-16.....	3	WASHER $\frac{3}{8}$ SAE FLT
24..	539 13 03-23.....	1	SPACER	54..	539 11 03-23.....	2	WASHER, HARDENED
25..	532 10 98-08.....	1	LATCH, HOOD	55..	819 09 10-16.....	4	WASHER $\frac{1}{4}$ FLAT SAE
26..	539 13 03-41.....	1	PLATE, OUTER	56..	539 10 95-52.....	2	WASHER $\frac{3}{16}$ LOCK
27..	539 13 21-24.....	1	PLATE, BACKING	57..	539 10 80-84.....	2	WASHER $\frac{3}{16}$ x $\frac{3}{4}$ x 16 GA
28..	539 13 21-22.....	1	PLATE, BACKING	58..	539 97 69-88.....	1	HAIRPIN
29..	539 11 56-67.....	1	KEY $\frac{3}{16}$ x $\frac{1}{2}$	59..	539 10 47-63.....	1	RETAINER U TYPE
30..	539 12 52-29.....	1	KEY $\frac{3}{16}$ x $1\frac{1}{2}$				

ACCESSORIES

Bagger

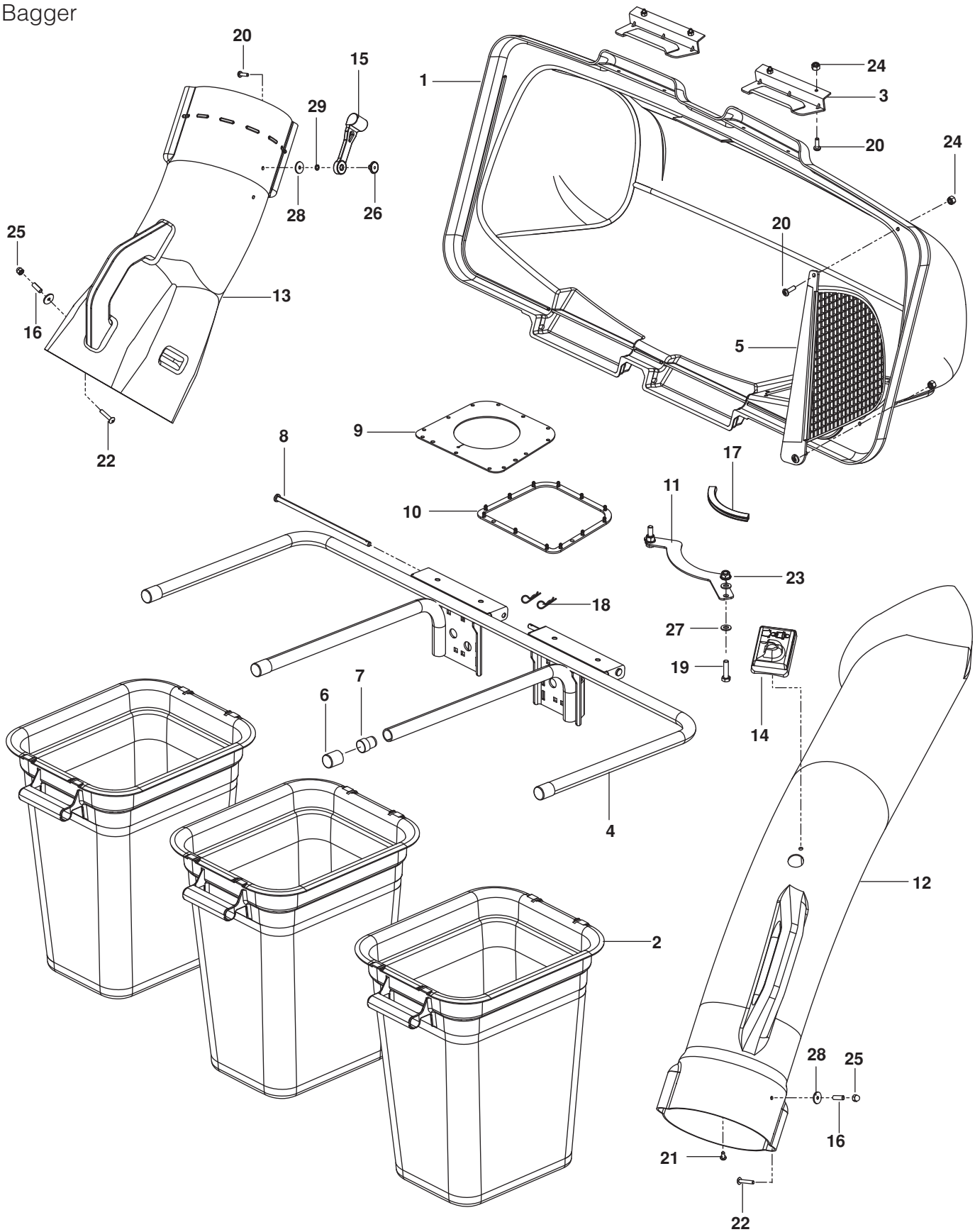

ACCESSORIES

ITEM	PART NO.	QTY.	DESCRIPTION	ITEM	PART NO.	QTY.	DESCRIPTION
1..	532 19 53-73.....	1	COVER	16..	539 10 80-85.....	2	SPACER, SPLIT
2..	532 40 02-26.....	3	CONTAINER, SOFT BAG	17..	539 11 22-94.....	1	FLEX TRIM
3..	532 13 08-95.....	2	HANDLE, BAGGER COVER	18..	539 10 80-96.....	2	HAIR PIN
4..	539 10 80-98.....	1	FRAME, BAGGER	19..	539 99 06-27.....	2	BOLT $\frac{5}{16}$ -18 x $1\frac{1}{4}$ HEX HD
5..	532 19 27-09.....	1	SCREEN, COVER	20..	539 97 69-52.....	7	SCREW #10-24 x $\frac{5}{8}$
6..	539 10 80-97.....	4	PLUG, TUBING END	21..	539 10 80-81.....	1	SCREW #10-14 x $\frac{1}{2}$
7..	522 80 13-01.....	2	PLUG, SPACER	22..	539 10 80-83.....	2	SCREW #10-24 x $1\frac{1}{8}$
8..	532 19 27-86.....	2	PIN, HINGE	23..	539 11 28-99.....	2	NUT $\frac{5}{16}$ -18 HEX FLG NYLOC
9..	532 19 25-50.....	1	SEAL, COVER	24..	539 97 69-77.....	6	NUT #10-24 CROWNLOCK
10..	532 19 26-03.....	1	GASKET, COVER	25..	539 10 80-86.....	2	NUT #10-24 ACORN
11..	539 11 02-81.....	1	SUPPORT, CHUTE	26..	539 10 80-89.....	1	WELD NUT, PLATED
12..	539 10 81-41.....	1	CHUTE, UPPER	27..	819 11 11-16.....	4	WASHER $\frac{5}{16}$ SAE
13..	539 13 02-94.....	1	CHUTE, MIDDLE	28..	539 10 80-84.....	3	WASHER $\frac{3}{16}$ x $\frac{3}{4}$ x 16 GA
14..	539 10 80-82.....	1	INDICATOR, BAG DUMP	29..	539 10 95-52.....	2	WASHER $\frac{3}{16}$ LOCK
15..	539 10 80-88.....	1	LATCH, HOOD				

ACCESSORIES

Guard, Mount and Belt

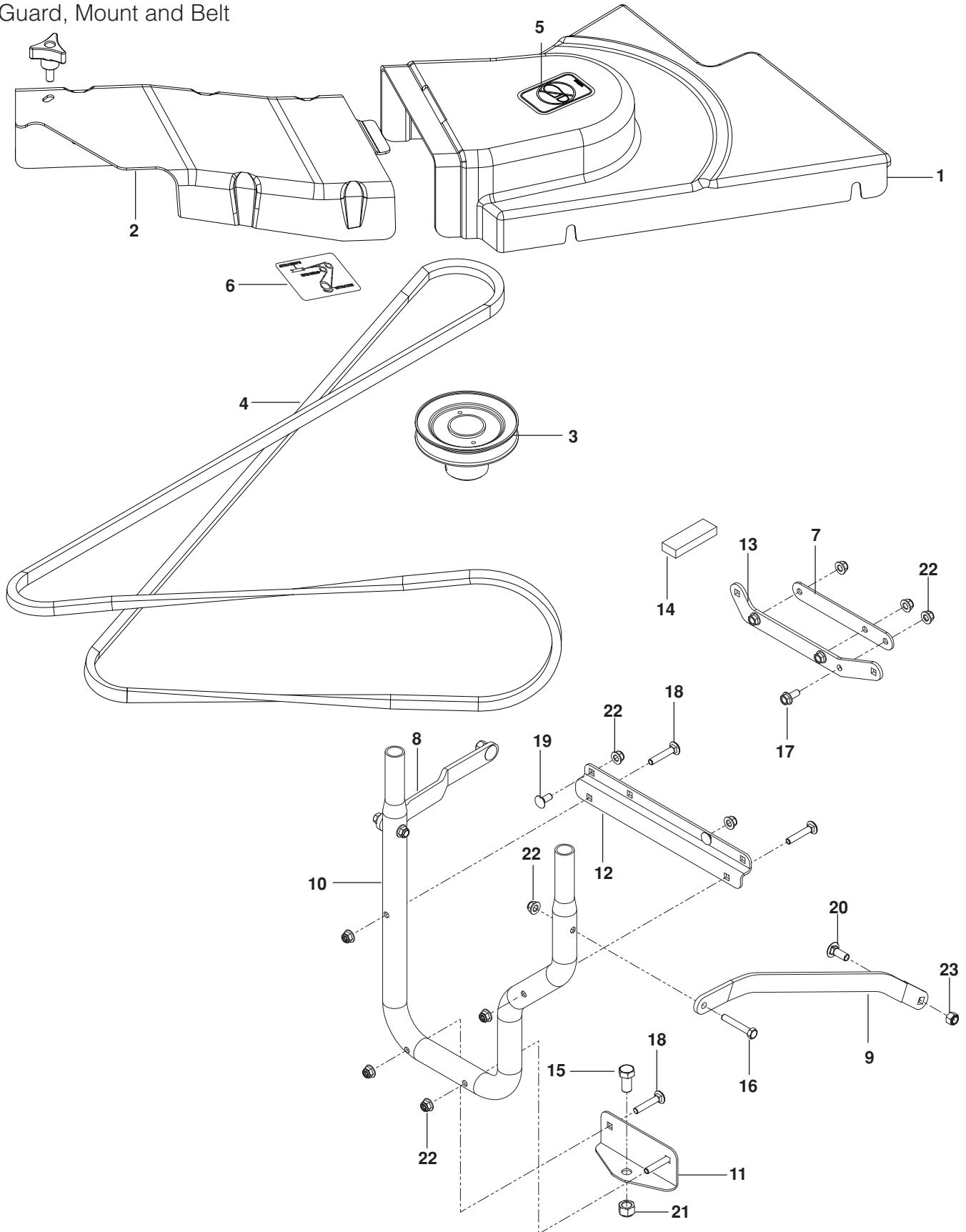

ACCESSORIES

ITEM	PART NO.	QTY.	DESCRIPTION	ITEM	PART NO.	QTY.	DESCRIPTION
1..	539 13 03-08.....	1SHIELD, BELT	13..	576 22 14-02.....	1BRACKET, SUPPORT, BLK
2..	539130309.....	1COVER, BELT	14..	539 11 02-90.....	1STRIP, FOAM
3..	539 13 03-21.....	1PULLEY	15..	874 78 06-16.....	1BOLT 1/2 -13 x 1 HEX HD
4..	539 13 03-48.....	1BELT	16..	874 78 05-32	2BOLT 5/16-18 x 2 HEX HD
5..	539 10 57-43.....	1DECAL, NO STEP	17..	525 46 47-01.....	3BOLT 5/16 -18 x 3/4 HEX FLG HD
6..	539130349.....	1DECAL, BELT ROUTING	18..	539 99 08-61.....	4BOLT 5/16 -16 x 1 3/4 RDHD SQNK
7..	576 22 15-02.....	1SPACER PLATE, BLK	19..	872 14 05-06.....	2BOLT 5/16 -18 x 3/4 RDHD SQNK
8..	575 95 33-02.....	1STRAP, LT, BLK	20..	872 14 06-08.....	2BOLT 3/8 -16 x 1 RDHD SQNK
9..	539 13 21-98.....	1STRAP, RT, BLK	21..	873 80 08-00.....	1NUT 1/2 NYLOC
10..	539 13 10-91	1TUBE, MOUNT	22..	539 11 28-99.....	11NUT 5/16 NYLOC
11..	539 13 21-92.....	1MOUNT HITCH, LOWER	23..	539 97 69-79.....	2NUT 3/8-16 NYLOC
12..	539 13 21-94.....	1MOUNT HITCH, UPPER				

ACCESSORIES

Mulch Kit

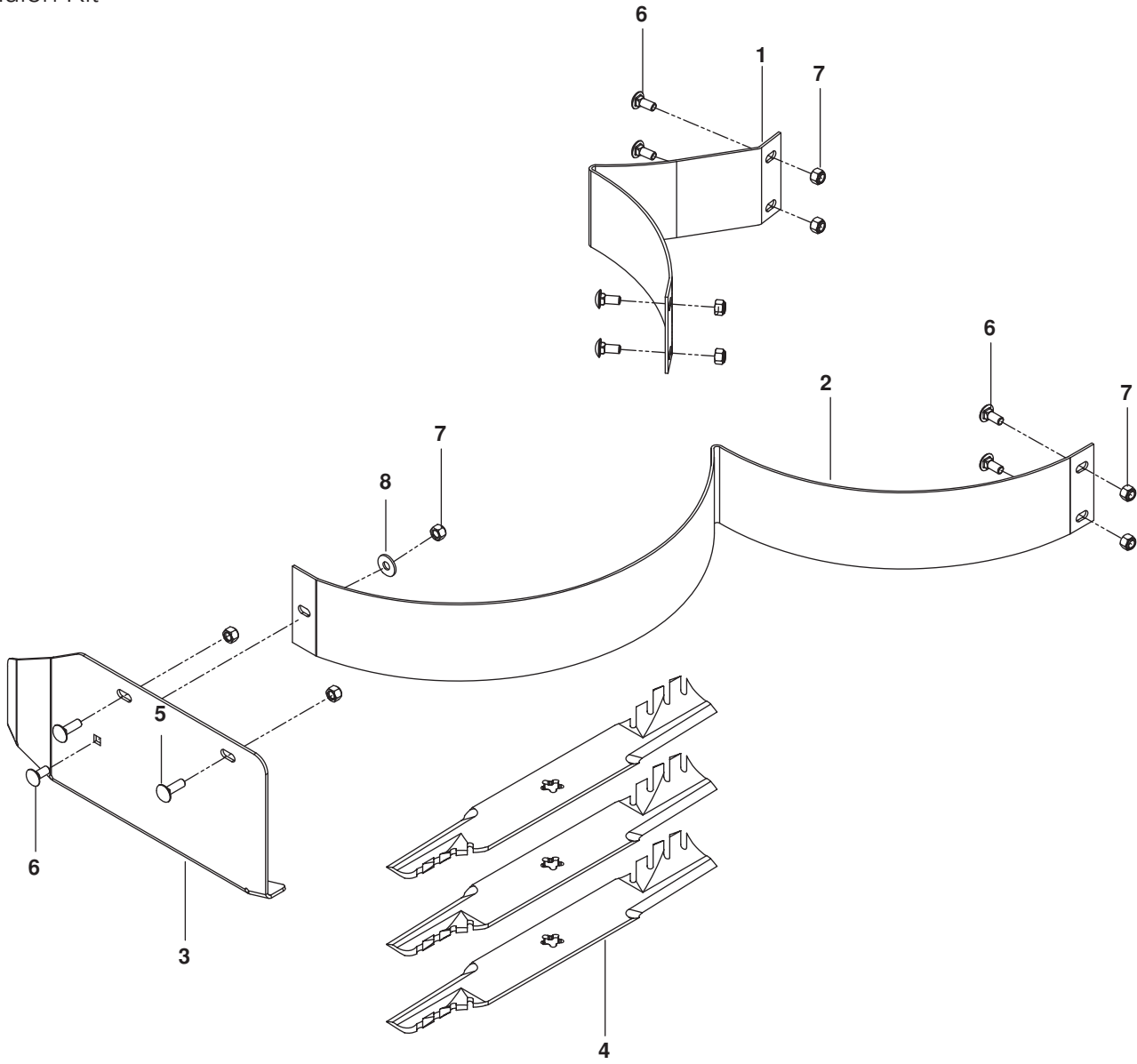

ACCESSORIES

ITEM PART NO. QTY. DESCRIPTION

- 1.. 539 11 24-21..... 1BAFFLE, LEFT
- 2.. 539 11 24-35..... 1BAFFLE, RIGHT
- 3.. 539 11 23-44..... 1MULCH CAP
- 4.. 521 98 15-01..... 3BLADE, 18" GATOR

ITEM PART NO. QTY. DESCRIPTION

- 5.. 539 99 02-08..... 2BOLT $\frac{5}{16}$ -18 x 1 RDHD SQNK
- 6.. 539 99 03-16..... 7BOLT $\frac{5}{16}$ -18 x $\frac{3}{4}$ RDHD SQNK
- 7.. 539 99 07-17..... 9HEX NUT $\frac{5}{16}$ -18 NYLOC
- 8.. 539 99 06-92..... 1WASHER $\frac{5}{16}$ STD FLT

www.husqvarna.com

115 71 58-27 Rev A
2014-09-15