

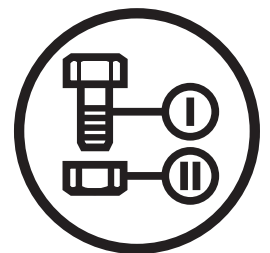

Parts Manual

P-ZT 54

Zero Turn Mower / 966613403-02



Please read the operator manual carefully and make sure you understand the instructions before using the machine.

When you need spare parts or support in service questions, warranty issues, etc., please consult the following professional:

This manual belongs to the machine with the manufacturing number:	Engine	Transmission

Manufacturing Number

The machine's manufacturing number can be found on the printed plate affixed to the engine compartment.

Stated on the plate, from the top are:

- The machine's type designation (I.D.).
- The manufacturer's type number (Model).
- The machine's serial number (Serial no.)

Please have the type designation and serial number available when ordering spare parts.

The engine's manufacturing number is stamped on one of the valve covers.

The plate states:

- The engine's model.
- The engine's type.
- Code

Please have these available when ordering spare parts.

The wheel motors and hydrostatic pumps have a barcode decal affixed at the rear.

Accessories Available

DFS Collection System	967 32 25-01
Drive Kit for DFS	966 40 71-01
Mulch Kit.....	966 05 04-01

CONTENTS

FRAME.....	4
ENGINE PLATE.....	6
STEERING	8
IGNITION.....	10
PARKING BRAKE	12
HYDRAULIC PUMP-MOTOR.....	14
HYDRAULIC FRAME	16
WHEELS	18
MOWER LIFT / DECK LIFT	20
MOWER DECK / CUTTING DECK.....	22
SEAT	24
DECALS.....	26
PROTECTION FRAME.....	28
ACCESSORIES	
BLOWER.....	30
CLAMSHELL REAR	32
CLAMSHELL FRONT.....	34
WEIGHTS, GUARDS, BLADES.....	36
MULCH KIT	38

NOTE: ALL FASTENERS ARE GRADE 5 UNLESS OTHERWISE SPECIFIED.

FRAME

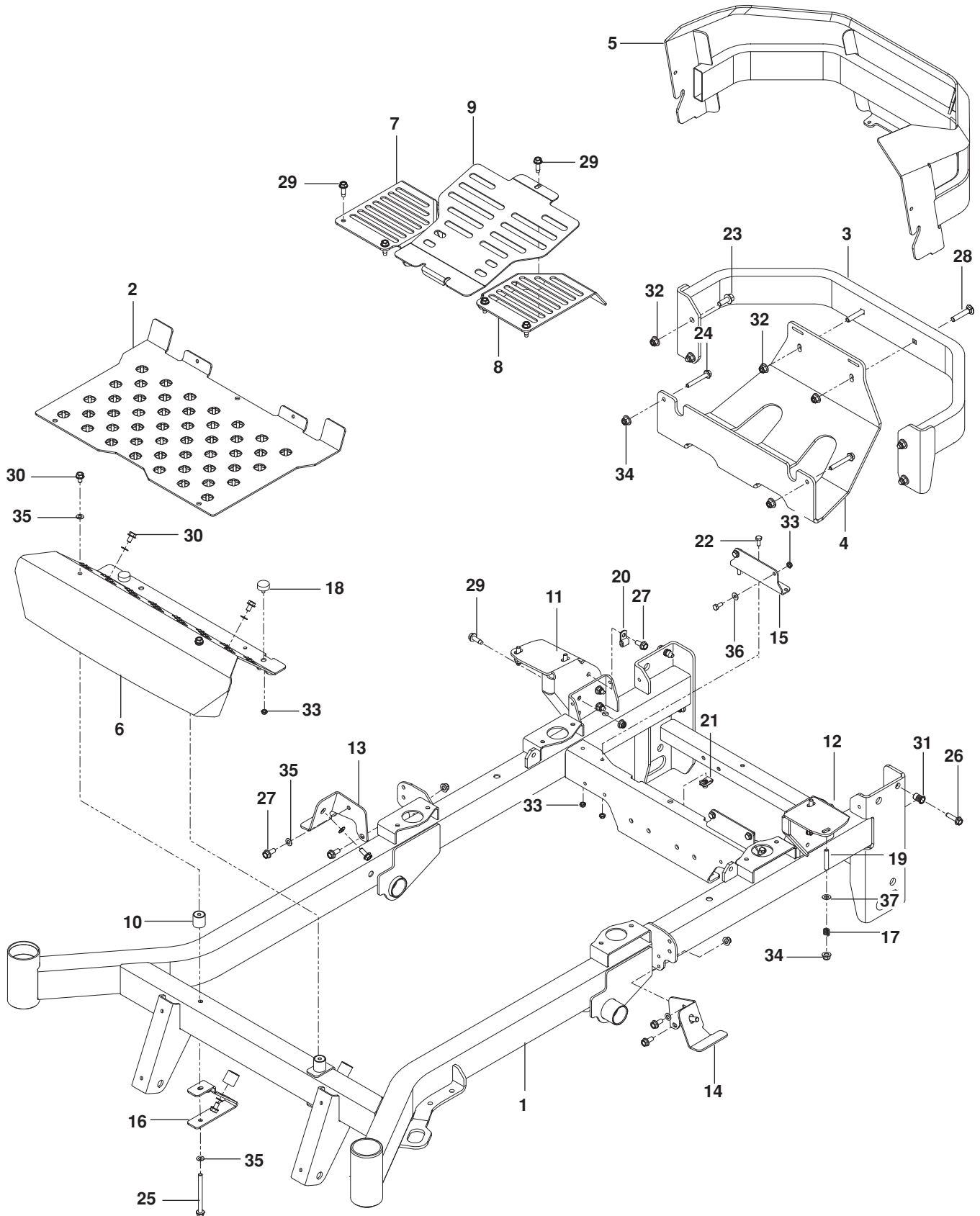

FRAME

ITEM	PART NO.	QTY.	DESCRIPTION	ITEM	PART NO.	QTY.	DESCRIPTION
1..	574 48 28-01.....	1	FRAME w/ SFTY DECAL ORG	20..	539 10 98-67.....	1	CLAMP, DOUBLE TUBE
2..	576 70 13-02.....	1	FLOOR PAN ORG	21..	539 10 47-63.....	1	RETAINER, U TYPE
3..	522 73 89-02.....	1	BUMPER, REAR ORG	22..	874 78 04-12.....	8	BOLT 1/4-20 X 5/8 HEX HD
4..	576 70 14-02.....	1	PLATE, SKID GRY	23..	525 61 28-01.....	4	BOLT 3/8-16 x 1 HEX FLG HD
5..	584 85 93-02.....	1	GUARD, REAR GRY	24..	574 23 38-01.....	2	BOLT 5/16-18 x 2 1/4 HEX FLG HD
6..	574 21 57-02.....	1	FOOTREST ORG	25..	539 13 17-80.....	2	BOLT 5/16-18 x 3 3/4 HEX FLG HD
7..	576 70 15-02.....	1	COVER, FAN RT BLK	26..	525 54 40-01.....	2	BOLT 5/16-18 x 1 1/4 TPBLT
8..	576 70 16-02.....	1	COVER, FAN LT BLK	27..	874 49 05-12.....	7	BOLT 5/16-18 x 3/4 HEX FLG HD
9..	576 70 17-02.....	1	COVER, CENTER BLK	28..	539 10 01-45.....	2	BOLT 3/8-16 x 2 RD HD SQNK
10..	510 08 32-01.....	4	MOUNT, F/F INSERT	29..	539 11 32-26.....	11	BOLT 5/16-18 x 1 THD FRM
11..	529 27 96-03.....	1	MOUNT, TANK RT RR	30..	539 99 08-58.....	6	SCREW 5/16-18 x 1/2 SLF TAP
12..	529 27 97-03.....	1	MOUNT, TANK LT RR	31..	539 11 10-28.....	2	NUTSERT 5/16-18
13..	529 27 99-03.....	1	MOUNT, TANK RT FRT	32..	521 99 65-01.....	2	NUT 3/8-16 HEX FLG NYLOC
14..	529 28 00-03.....	1	MOUNT, TANK LT FRT	33..	539 10 81-20.....	10	NUT 1/4-20 HEX THIN NYLOC
15..	576 45 36-02.....	2	MOUNT, TANK BLK	34..	539 11 28-99.....	14	NUT 5/16-18 HEX FLG NYLOC
16..	510 04 03-01.....	2	BRACKET, REST MOUNT	35..	539 10 96-00.....	8	WASHER 5/16 DISC SPRING
17..	539 10 28-45.....	4	SPRING, TANK MOUNT	36..	539 99 00-55.....	4	WASHER 1/4 SAE FLAT
18..	575 81 15-01.....	2	BUMPER, 1/4-20 STUD 3/8"	37..	819 11 11-16.....	4	WASHER 5/16 SAE FLAT
19..	539 10 25-02.....	4	STUD, FUEL TANK				

ENGINE PLATE

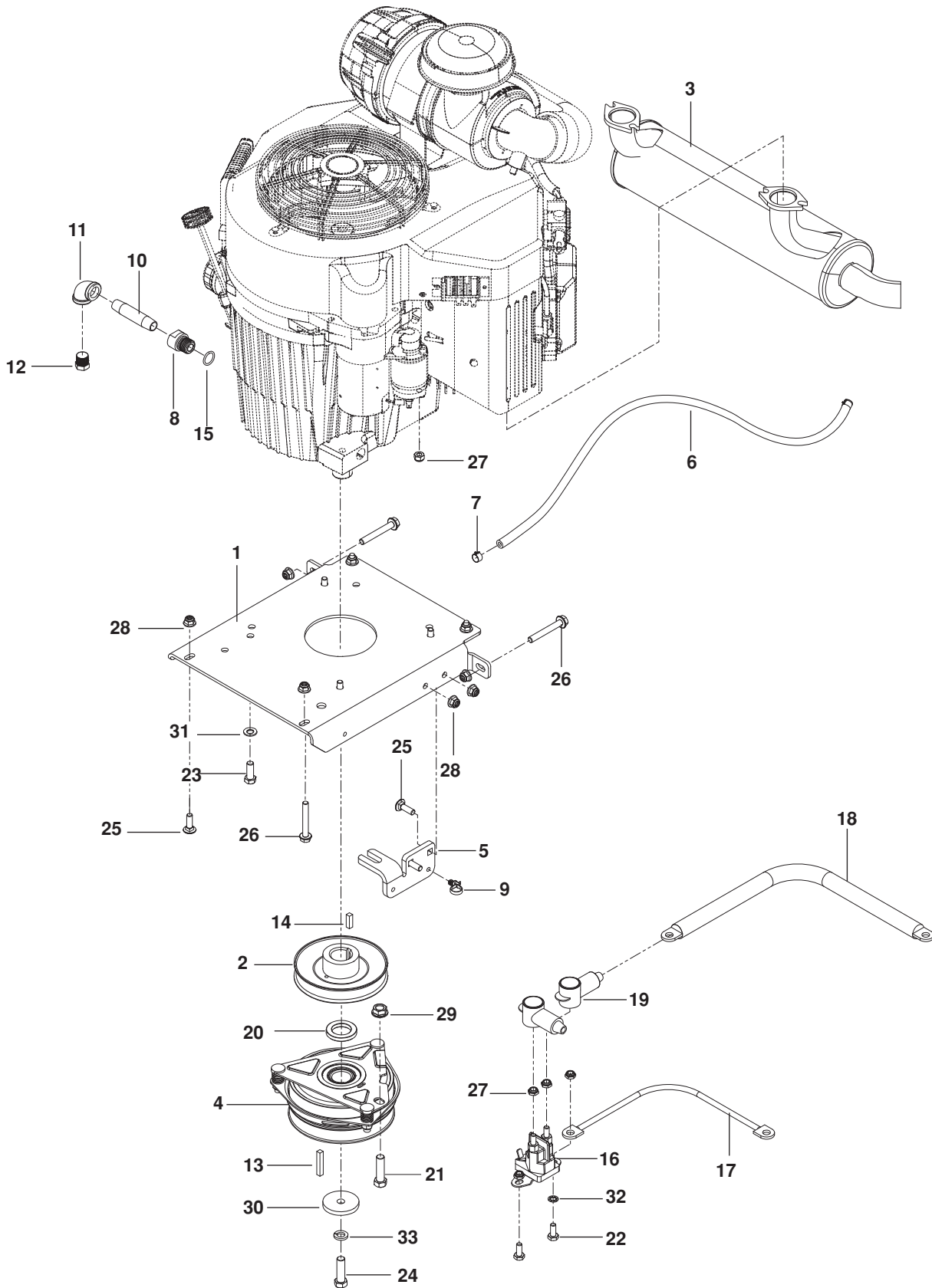

ENGINE PLATE

ITEM	PART NO.	QTY.	DESCRIPTION	ITEM	PART NO.	QTY.	DESCRIPTION
1..	510 00 46-02.....	1	PLATE, ENGINE BLK	20..	525 31 39-01.....	1	SPACER
2..	510 01 98-01.....	1	PULLEY, ENGINE	21..	539 10 48-67.....	1	BOLT 7/16-14 x 1 1/4 HEX HD
3..	525 75 02-01.....	1	MUFFLER	22..	539 99 00-72.....	2	BOLT 1/4-20 x 5/8 HEX HD
4..	539 11 34-37.....	1	CLUTCH, GT 3.5	23..	539 99 05-63.....	4	BOLT 3/8-16 x 1 HEX HD
5..	522 67 67-02.....	1	STOP, CLUTCH	24..	539 10 01-41.....	1	BOLT 7/16-20 x 1 1/2 HEX HD
6..	539 10 55-26.....	1	FUEL LINE 18"	25..	539 99 02-08.....	4	BOLT 5/16-18 x 1 RD HD SQNK
7..	539 91 22-22.....	2	CLAMP	26..	574 23 38-01.....	3	BOLT 5/16-18 x 2 1/4 HEX FLG
8..	539 11 96-80.....	1	ADAPTOR, OIL DRAIN	27..	539 10 81-20.....	5	NUT 1/4-20 HEX THIN NYLOC
9..	505 28 00-01.....	1	TIE WRAP w/ CLIP	28..	539 11 28-99.....	8	NUT 5/16-18 HEX FLG NYLOC
10..	539 11 89-11.....	1	PIPE 3/8 NPT x 3"	29..	539 10 25-82.....	1	NUT 7/16-14 HEX WHIZ LK
11..	539 10 50-72.....	1	ELBOW 90°	30..	539 12 56-26.....	1	WASHER, BLADE
12..	522 83 70-01.....	1	PLUG 3/8 NPTF DRAIN	31..	539 10 25-93.....	4	WASHER 3/8 SPRING
13..	539 91 02-10.....	1	KEY 1/4 SQ x 2	32..	539 99 00-53.....	1	WASHER 1/4 INT TOOTH LK
14..	539 10 53-08.....	1	KEY 1/4 SQ x 1	33..	539 99 02-47.....	1	WASHER 7/16 SLW
15..	539 10 96-18.....	1	O-RING	NOT SHOWN			
16..	539 10 17-14.....	1	SOLENOID	525 55 42-01.....	1	ENGINE HARNESS, KAW	
17..	539 10 54-09.....	1	GROUND WIRE	574 82 58-01.....	1	KIT, SPARK ARRESTOR	
18..	539 10 27-57.....	1	CABLE, POSITIVE	586 83 97-01.....	2	GASKET, EXHAUST	
19..	539 10 27-59.....	2	INSULATOR	-----	1	ENGINE, KAWASAKI FX751V 24.5 HP For engine service and replacement parts, see a Kawasaki dealer	

STEERING

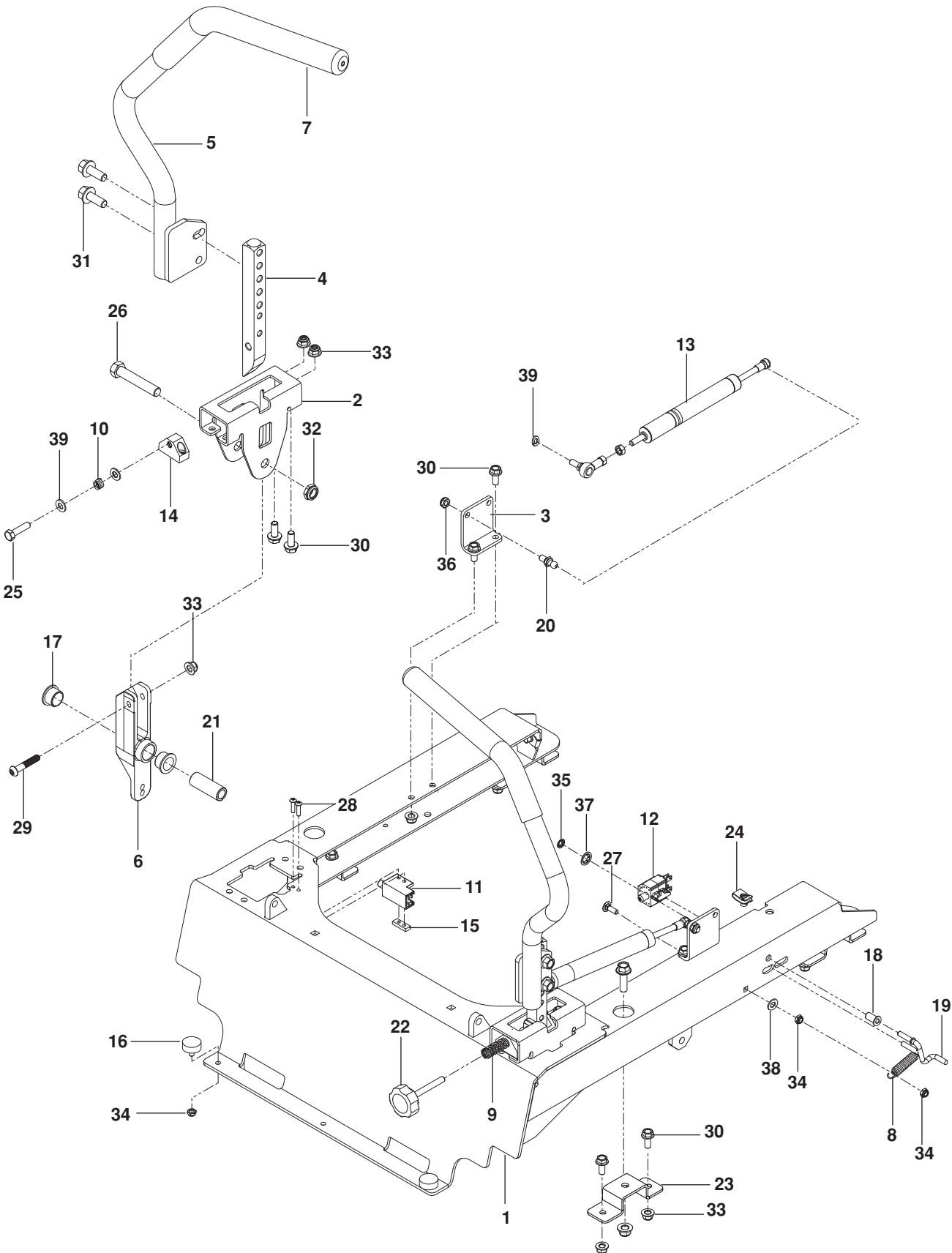

STEERING

ITEM	PART NO.	QTY.	DESCRIPTION	ITEM	PART NO.	QTY.	DESCRIPTION
1..	577 32 77-02.....	1	FRAME, SEAT MOUNT ORG	20..	539 11 06-07.....	2	BALL STUD 10MM
2..	586 73 72-02.....	2	BRACKET, CONTROL	21..	577 25 24-01.....	2	SPACER, PIVOT
3..	577 26 58-01.....	2	BRACKET, DAMPENER	22..	539 13 17-99.....	1	KNOB
4..	574 26 94-01.....	2	LEVER, MOTION	23..	522 84 97-02.....	4	MOUNT, BLK
5..	577 04 24-03.....	1	LEVER, w/ GRIP, RT	24..	539 10 47-63.....	4	RETAINER, U TYPE
	577 04 23-03.....	1	LEVER, w/ GRIP, LT	25..	874 78 05-20.....	1	BOLT $\frac{5}{16}$ -18 x $1\frac{1}{4}$ HEX HD TPBLT
6..	576 14 03-02.....	2	LEVER, CONTROL	26..	874 78-08 44.....	2	BOLT $\frac{1}{2}$ -13 x $2\frac{3}{4}$ HEX HD
7..	539 13 08-94.....	2	GRIP, LEVER	27..	872 11 04-06.....	1	BOLT $\frac{1}{4}$ -20 x $\frac{3}{4}$ RD HD SQNK GR2
8..	539 02 00-35.....	1	SPRING	28..	574 82 27-01.....	4	SCREW 10-24 x $\frac{3}{4}$ SKT HD
9..	576 85 03-01.....	1	SPRING	29..	576 85 04-02.....	2	SCREW $\frac{5}{16}$ -18 x $1\frac{3}{4}$ BTN HD
10..	539 10 28-45.....	1	SPRING	30..	874 49 05-12.....	20	BOLT $\frac{5}{16}$ -18 x $\frac{3}{4}$ HEX FLG HD
11..	539 10 95 53.....	2	SWITCH N.C.	31..	525 61 28-01.....	4	BOLT $\frac{3}{8}$ -16 x 1 HEX FLG HD
12..	539 11 37-92.....	1	SWITCH, BRAKE (3-POLE)	32..	539 10 80-10.....	2	NUT $\frac{1}{2}$ -13 HEX JAM NYL GR2
13..	516 02 03-01.....	2	DAMPENER ASSY	33..	539 11 28-99.....	20	NUT $\frac{5}{16}$ -18 HEX FLG NYLOC
14..	581 43 75-01.....	2	BLOCK, TRACKING	34..	539 10 81-20.....	4	NUT $\frac{1}{4}$ -20 HEX THIN NYLOC
15..	539 13 15-19.....	2	PLATE, TAPPED	35..	539 10 22-34.....	1	NUT $\frac{1}{4}$ PUSH
16..	575 81 15-01.....	2	BUMPER	36..	873 80 05-00.....	2	NUT $\frac{5}{16}$ -18 HEX NYLOC
17..	539 13 15-18.....	4	BEARING, FLANGE	37..	539 91 38-47.....	2	NUT $\frac{3}{8}$ RETAINER
18..	511 59 49-01.....	1	BUSHING $\frac{1}{4}$ FLANGE	38..	819 11 11-16.....	3	WASHER $\frac{5}{16}$ SAE FLAT
19..	511 59 50-01.....	1	LINK, SWITCH	39..	810 03 05-00.....	2	WASHER $\frac{5}{16}$ SLW

IGNITION

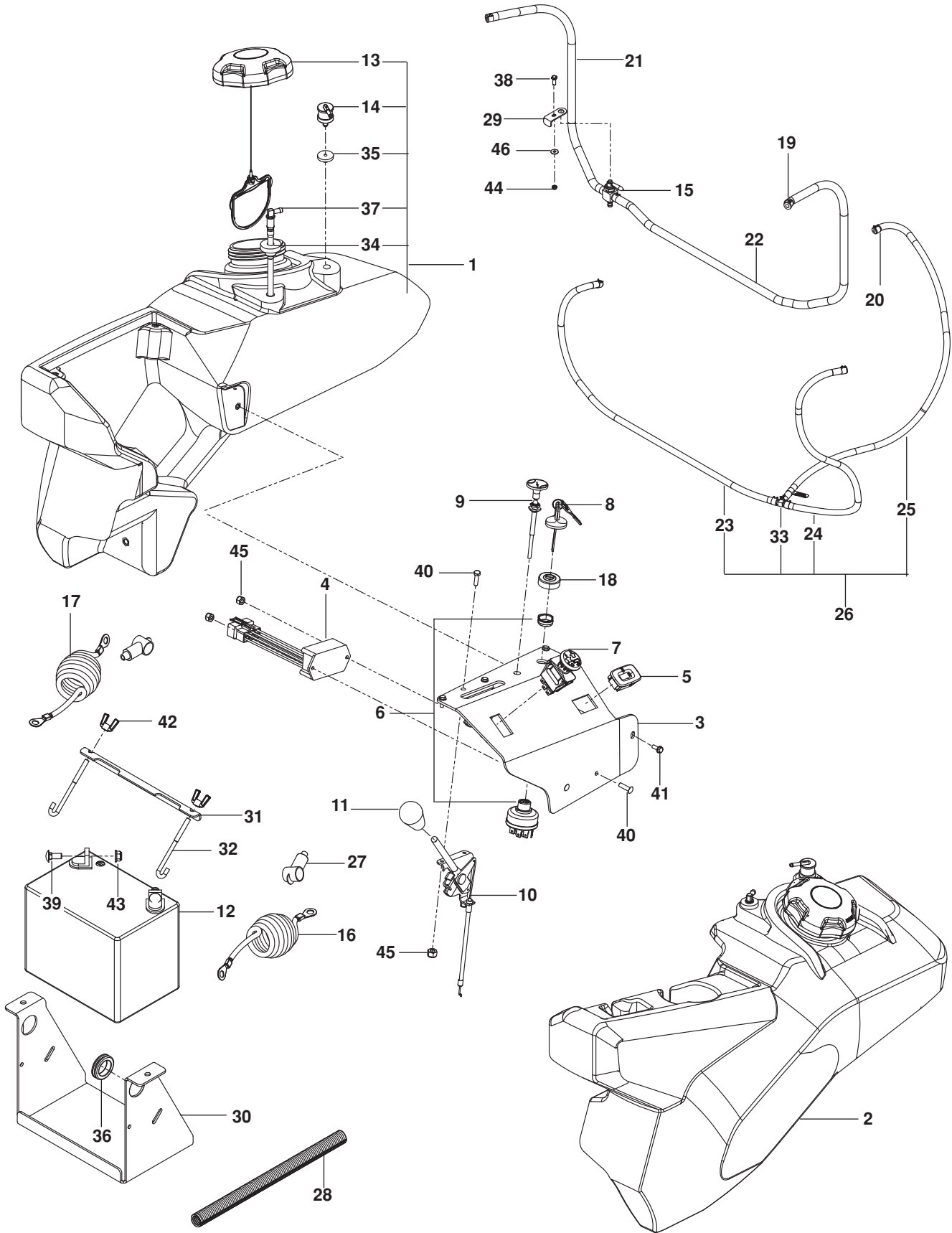

IGNITION

ITEM	PART NO.	QTY.	DESCRIPTION	ITEM	PART NO.	QTY.	DESCRIPTION
1..	584 28 04-01.....	1	TANK ASSY, RT GRY	24..	576 66 06-03.....	1	HOSE 3/16 x 38"
2..	584 28 03-01.....	1	TANK ASSY, LT GRY	25..	576 66 06-04.....	1	HOSE 3/16 30"
3..	529 28 02-02.....	1	PANEL, CONTROL	26..	576 54 77-01.....	1	VAPOR LINE ASSY
4..	574 51 40-01.....	1	TIMER, SEAT	27..	539 10 27-59.....	2	INSULATOR
5..	586 16 18-01.....	1	METER, SERVICE	28..	574 23 53-01.....	1	LOOM 5/8 SPLIT
6..	574 45 54-01.....	1	SWITCH, IGNITION	29..	577 10 40-02.....	1	BRACKET, VALVE
7..	539 13 16-27.....	1	SWITCH, PTO 10 AMP	30..	510 02 99-02.....	1	BRACKET, BATTERY BLK
8..	574 45 55-01.....	1	KEY, IGNITION	31..	510 03 00-01.....	1	BRACKET, BATTERY MOUNT
9..	574 20 69-01.....	1	CABLE, CHOKE	32..	510 06 40-01.....	2	J HOOK
10..	574 20 70-01.....	1	CABLE, THROTTLE	33..	574 20 66-02.....	1	TEE 3/16 FUEL LINE
11..	539 13 26-24.....	1	KNOB	34..	539 10 52-45.....	2	GROMMET, RUBBER
12..	539 10 24-36.....	1	BATTERY	35..	576 61 82-01.....	2	GROMMET, CHECK VALVE
13..	575 01 81-01.....	2	CAP w/ TETHER, FUEL	36..	539 10 59-74.....	1	GROMMET
14..	576 61 81-01.....	2	VALVE, FUEL CHECK	37..	525 86 54-01.....	2	FITTING, FUEL
15..	539 10 26-79.....	1	VALVE, FUEL	38..	539 99 05-80.....	1	BOLT 1/4-20 x 3/4
16..	522 71 87-01.....	1	CABLE, POSITIVE	39..	872 14 05-06.....	2	BOLT 5/16-18 x 3/4 RD HD SQNK
17..	522 71 07-01.....	1	CABLE, NEGATIVE	40..	574 82 27-01.....	4	SCREW 10-24 x 3/4 SKT HD
18..	539 10 31-78.....	1	CAP, IGNITION SWITCH	41..	539 11 43-41.....	3	SCREW 10-24 x 3/8 SKT HD
19..	539 91 22-22.....	4	CLAMP, HOSE	42..	539 99 09-97.....	2	WINGNUT 1/4-20 NYLOC
20..	575 43 65-01.....	6	CLAMP, HOSE	43..	539 11 28-99.....	2	NUT 5/16-18 HEX FLG NYLOC
21..	587 04 48-22.....	1	HOSE 1/4 x 22"	44..	539 10 81-20.....	1	NUT 1/4-20 HEX THIN NYLOC
22..	587 04 48-38.....	1	HOSE 1/4 x 38"	45..	539 97 69-77.....	4	NUT 10-24 HEX NYLOC
23..	576 66 06-01.....	1	HOSE 3/16 x 39"	46..	539 99 05-98.....	1	WASHER 1/4 FLAT

PARKING BRAKE

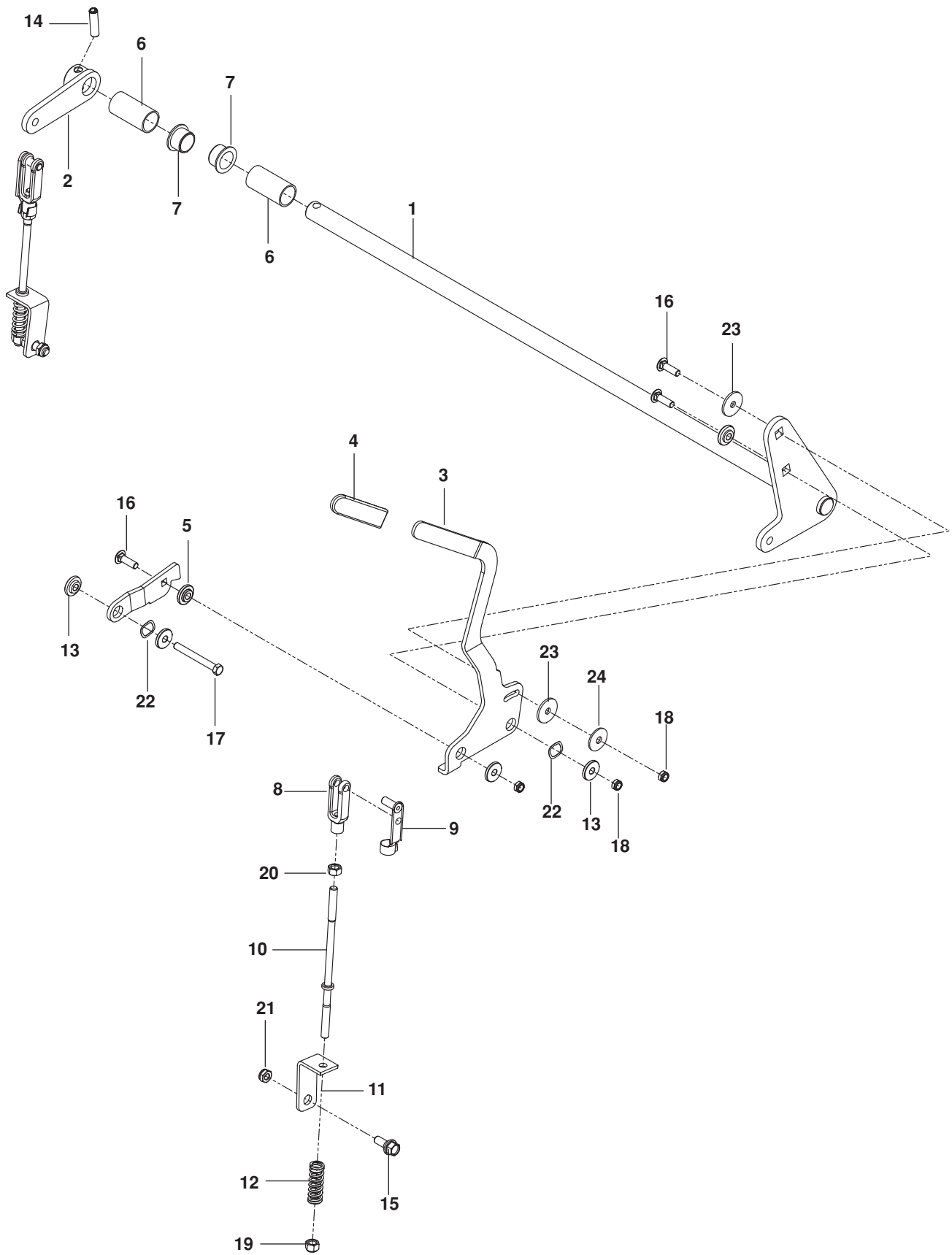

PARKING BRAKE

ITEM	PART NO.	QTY.	DESCRIPTION	ITEM	PART NO.	QTY.	DESCRIPTION
1..	576 41 63-01.....	1	SHAFT, BRAKE	13..	539 13 21-61.....	6	BUSHING, BRAKE
2..	576 41 64-01.....	1	ARM, RT BRAKE	14..	539 11 06-31.....	1	ROLL PIN ⁵ / ₁₆ " DIA.
3..	515 98 00-02.....	1	LEVER, BRAKE	15..	539 11 03-03.....	2	BOLT ⁵ / ₁₆ SHOULDER
4..	539 97 65-26.....	1	GRIP, LEVER	16..	539 10 04-13.....	3	BOLT ³ / ₈ -16 x 1¼ RD HD SQNK
5..	515 98 03-01.....	1	LINK, FOLLOWER	17..	539 92 34-63.....	1	BOLT ³ / ₈ -16 x 3¼
6..	576 76 40-01.....	2	SPACER, SHAFT	18..	539 20 02-82.....	3	NUT ³ / ₈ -16 HEX JAM NYLOC
7..	539 13 15-18.....	2	BEARING, FLANGE	19..	539 11 09-43.....	2	NUT ⁵ / ₁₆ -24 HEX NYLOC
8..	539 97 64-81.....	2	YOKE	20..	539 99 02-23.....	2	NUT ⁵ / ₁₆ -24 HEX
9..	522 70 59-01.....	2	PIN ³ / ₈ CLEVIS SPRING	21..	539 11 56-17.....	2	NUT ⁵ / ₁₆ -18 HEX NYLOC
10..	576 45 95-01.....	2	LINKAGE, BRAKE	22..	539 13 30-07.....	2	WASHER, WAVE
11..	575 22 98-02.....	2	BRACKET, BRAKE	23..	525 49 09-01.....	2	WASHER, FRICTION
12..	575 23 03-01.....	1	SPRING	24..	539 91 20-63.....	1	WASHER, CONE

HYDRAULIC PUMP-MOTOR

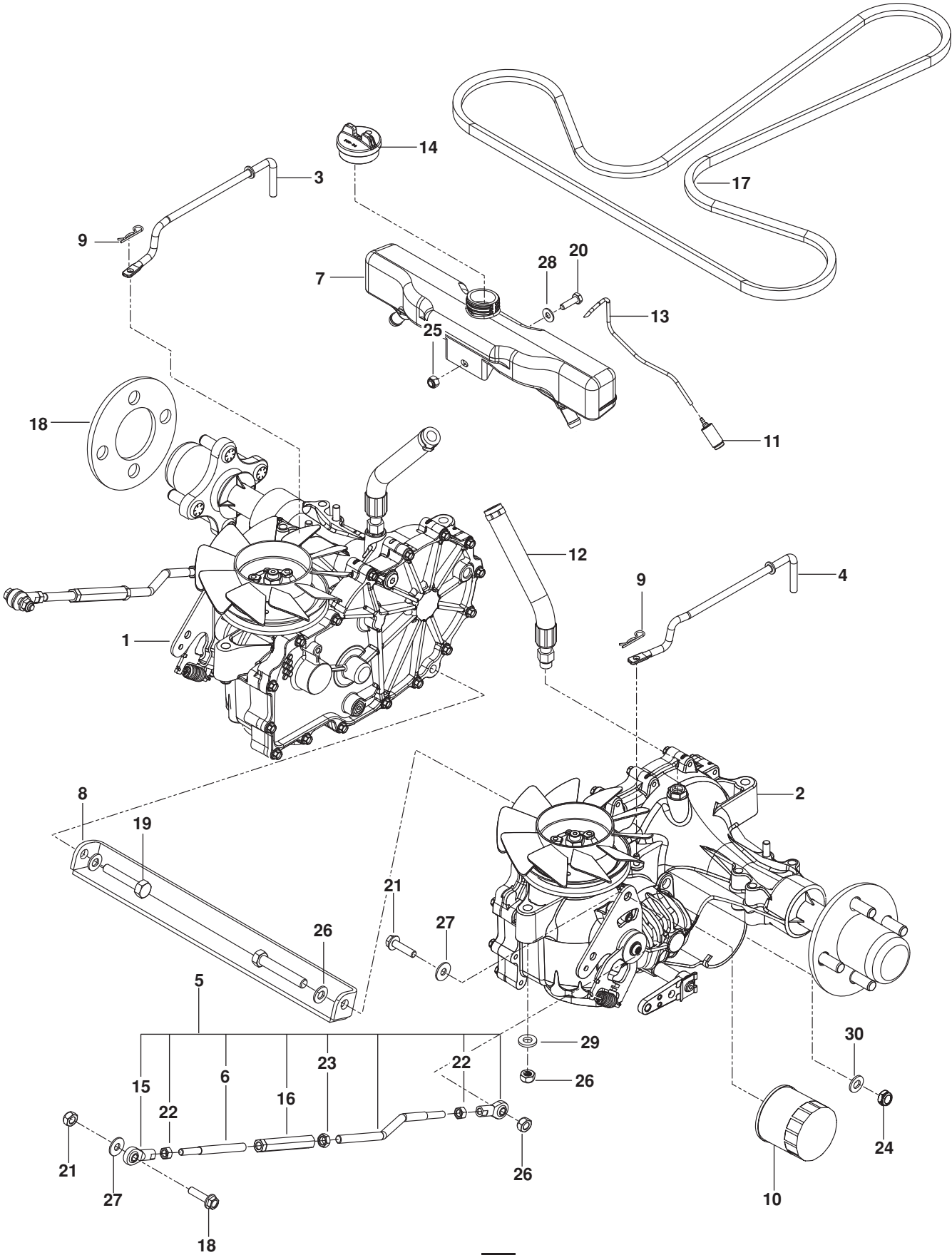

HYDRAULIC PUMP-MOTOR

ITEM	PART NO.	QTY.	DESCRIPTION	ITEM	PART NO.	QTY.	DESCRIPTION
1..	574 56 91-02.....	1	TRANS, ZT-3400, RT	16..	539 10 91-49.....	2	TURNBUCKLE $\frac{3}{8}$
2..	574 56 91-01.....	1	TRANS, ZT-3400, LT	17..	576 66 72-01.....	1	BELT
3..	539 13 16-18.....	1	LINKAGE, RT BYPASS	18..	580 90-62-02	2	SPACER, WHEEL
4..	539 13 16-16.....	1	LINKAGE, LT BYPASS	19..	539 10 85-51.....	2	BOLT $\frac{3}{8}$ -16 x $2\frac{1}{4}$ GR 8 HEX HD
5..	576 41 57-01.....	2	LINKAGE, CONTROL ASSY	20..	539 99 06-42.....	1	BOLT $\frac{1}{4}$ -20 x $\frac{7}{8}$ HEX HD
6..	522 55 92-01.....	2	LINKAGE, CONTROL FT	21..	525 54 40-01.....	4	BOLT $\frac{5}{16}$ -18 x $1\frac{1}{4}$ TPBLT
7..	584 80 75-01.....	1	TANK, EXPANSION	22..	539 99 02-23.....	4	NUT $\frac{5}{16}$ -24 HEX
8..	851 82 02-02.....	1	BRACKET	23..	539 10 87-32.....	2	NUT $\frac{3}{8}$ -24 HEX JAM
9..	539 97 69-88.....	2	HAIRPIN COTTER	24..	581 84 81-01.....	2	NUT $\frac{3}{8}$ -16 LK GR C
10..	539 11 34-66.....	2	FILTER, HYDRO	25..	539 97 69-78.....	1	NUT $\frac{1}{4}$ -20 HEX NYL
11..	530 09 56-46.....	1	FILTER	26..	585 47 68-01.....	4	NUT $\frac{5}{16}$ -18 HEX LK
12..	574 89 21-01.....	2	HOSE, EXPANSION	27..	539 99 06-92.....	4	WASHER $\frac{5}{16}$ STD FLT
13..	586 06 75-01.....	1	HOSE, FUEL LINE	28..	539 99 00-55.....	1	WASHER $\frac{1}{4}$ SAE FLT
14..	586 07 27-01.....	1	CAP, TANK	29..	585 47 70-01.....	2	WASHER $\frac{5}{16}$ SAE FLAT
15..	539 10 25-90.....	4	BALL END, RT	30..	539 99 01-22.....	4	WASHER $\frac{3}{8}$ SAE FLT

HYDRAULIC FRAME

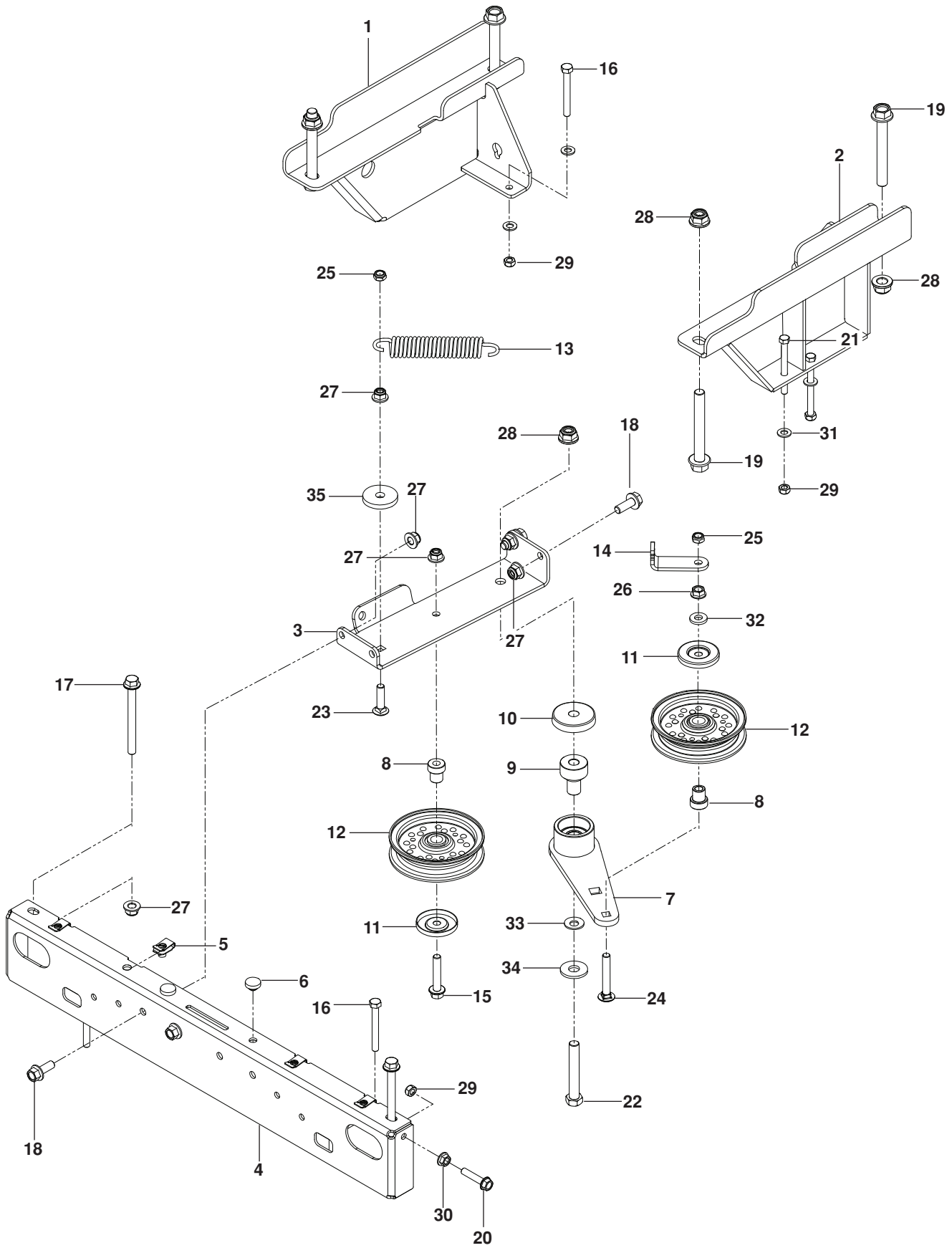

HYDRAULIC FRAME

ITEM	PART NO.	QTY.	DESCRIPTION	ITEM	PART NO.	QTY.	DESCRIPTION
1..	581 82 13-02.....	1	MOUNT, TRANS RT BLK	19..	525 54 48-01.....	4	BOLT 1/2-13 x 4 GR 8
2..	581 82 12-02.....	1	MOUNT, TRANS LT BLK	20..	525 46 54-01.....	4	BOLT 5/16-18 x 1 1/2
3..	576 45 99-02.....	1	MOUNT, IDLER BLK	21..	585 47 67-01.....	4	BOLT HEX HD 5/16-18 x 3
4..	581 81 30-02.....	1	MOUNT, FT BLK	22..	539 10 34-33.....	1	BOLT HEX HD 1/2-13 x 3 1/4
5..	539 10 47-63.....	4	RETAINER, U TYPE	23..	539 10 93-45.....	1	BOLT RD HD SQNK 3/8-16 x 1 1/2
6..	539 10 25-87.....	2	GROMMET, BUMPER	24..	539 12 81-01.....	1	BOLT 3/8-16 x 2 1/2 CARRIAGE
7..	510 04 16-03.....	1	ARM, IDLER w/ BEARINGS	25..	539 20 02-82.....	2	NUT 3/8-16 HEX JAM NYLOC
8..	525 43 56-01.....	2	PIVOT, IDLER	26..	539 99 06-13.....	1	NUT 3/8-16 HEX WHIZLK
9..	510 20 63-01.....	1	PIVOT, BEARING	27..	521 99 65-01.....	8	NUT 3/8-16 HEX FLG NYLOC
10..	539 11 46-62.....	1	SHIELD, DUST	28..	521 99 11-01.....	5	NUT 1/2-13 HEX FLG NYLOC
11..	510 25 45-01.....	2	SHIELD, DUST	29..	585 47 68-01.....	5	NUT 5/16-18 HEX LK
12..	539 97 66-88.....	2	PULLEY, IDLER	30..	539 99 05-85.....	1	NUT 5/16-18 HEX WHIZLK
13..	575 47 09-01.....	1	SPRING, EXTENSION	31..	585 47 70-01.....	3	WASHER 5/16 SAE FLAT
14..	576 45 98-01.....	1	BRACKET, SPRING	32..	522 02 34-01.....	1	WASHER 3/8 THICK
15..	874 49 06-32.....	1	BOLT 3/8-16 x 2	33..	539 11 55-28.....	1	WASHER 1/2 BELLEVILLE
16..	585 47 66-01.....	4	BOLT 5/16-18 x 2 1/2 HEX FLG	34..	539 10 95-54.....	1	WASHER 1/2 FLAT
17..	521 99 66-01.....	2	BOLT 3/8-16 x 4	35..	539 10 65-04.....	1	WASHER, HEAVY
18..	525 61 28-01.....	4	BOLT 3/8-16 x 1				

WHEELS

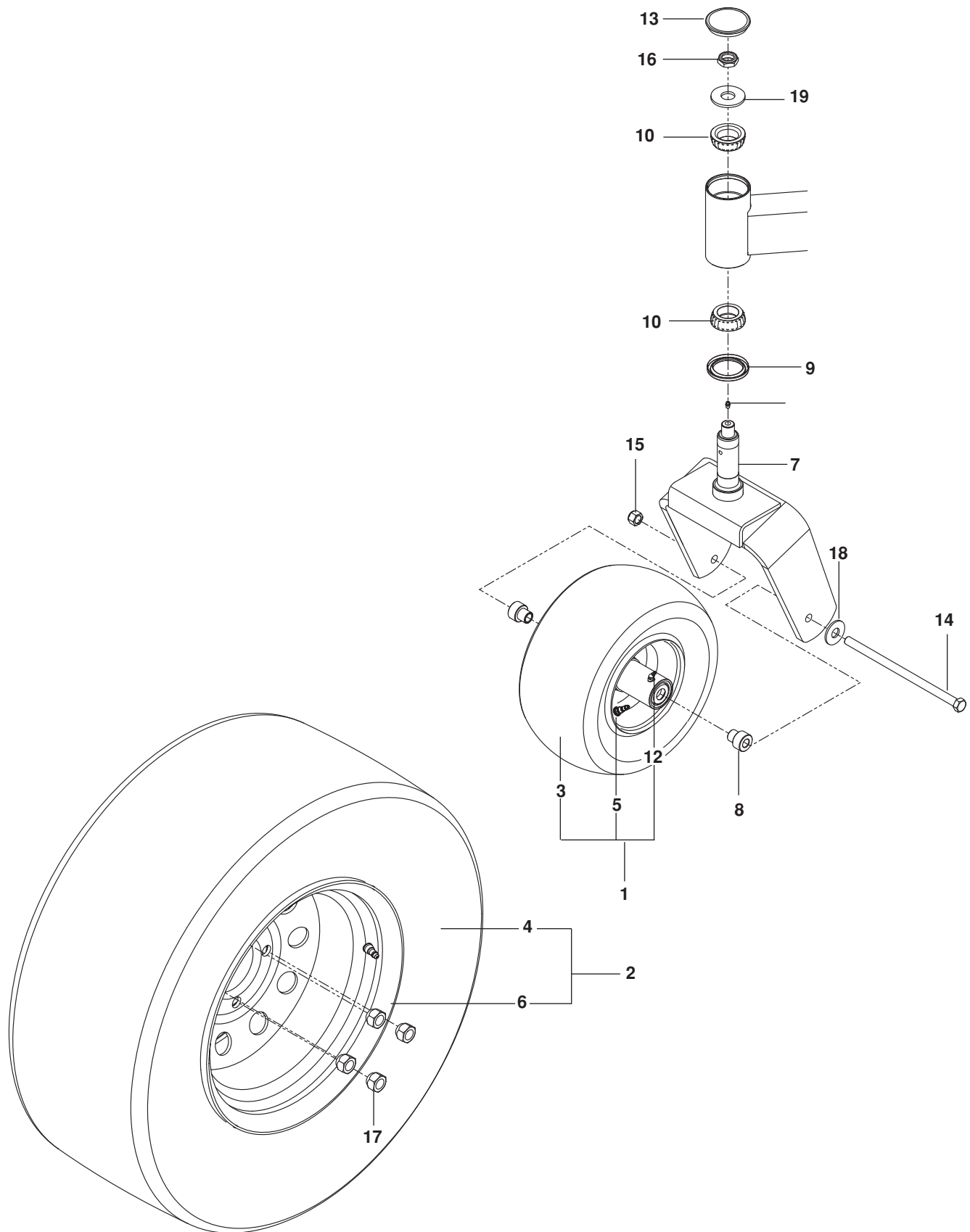

WHEELS

ITEM	PART NO.	QTY.	DESCRIPTION	ITEM	PART NO.	QTY.	DESCRIPTION
1..	539 10 55-21.....	2.....	ASSY, TIRE 13 x 6.5	11..	539 10 14-74.....	2.....	ZERK
2..	522 90 51-01.....	2.....	ASSY, TIRE 23 x 10.5	12..	539 10 33-00.....	2.....	ZERK ¼ -28 ANGLED
3..	539 10 74-31.....	2.....	TIRE 23 x 10.5 TURF MASTER	13..	510 03 40-01.....	2.....	CAP, DUST
4..	539 10 55-22.....	2.....	TIRE	14..	539 10 55-17.....	2.....	BOLT ½-13 x 9½ HEX NYLOC
5..	575 62 21-01.....	2.....	RIM	15..	521 99 11-01.....	2.....	NUT ½-13 HEX FLG NYLOC
6..	522 90 51-02.....	2.....	RIM	16..	522 84 26-01.....	2.....	NUT ¾-16 HEX THIN NYLOC
7..	525 61 19-02.....	2.....	YOKE, CASTER, BLUE	17..	539 10 11-73.....	8.....	NUT, LUG
8..	539 10 55-18.....	4.....	SPACER, AXLE	18..	539 99 02-50.....	2.....	WASHER ½ SAE
9..	510 03 43-01.....	2.....	SEAL, BEARING	19..	574 82 47-01.....	2.....	WASHER ¾ HARDENED
10..	510 03 44-03.....	4.....	CONE				

MOWER LIFT / DECK LIFT

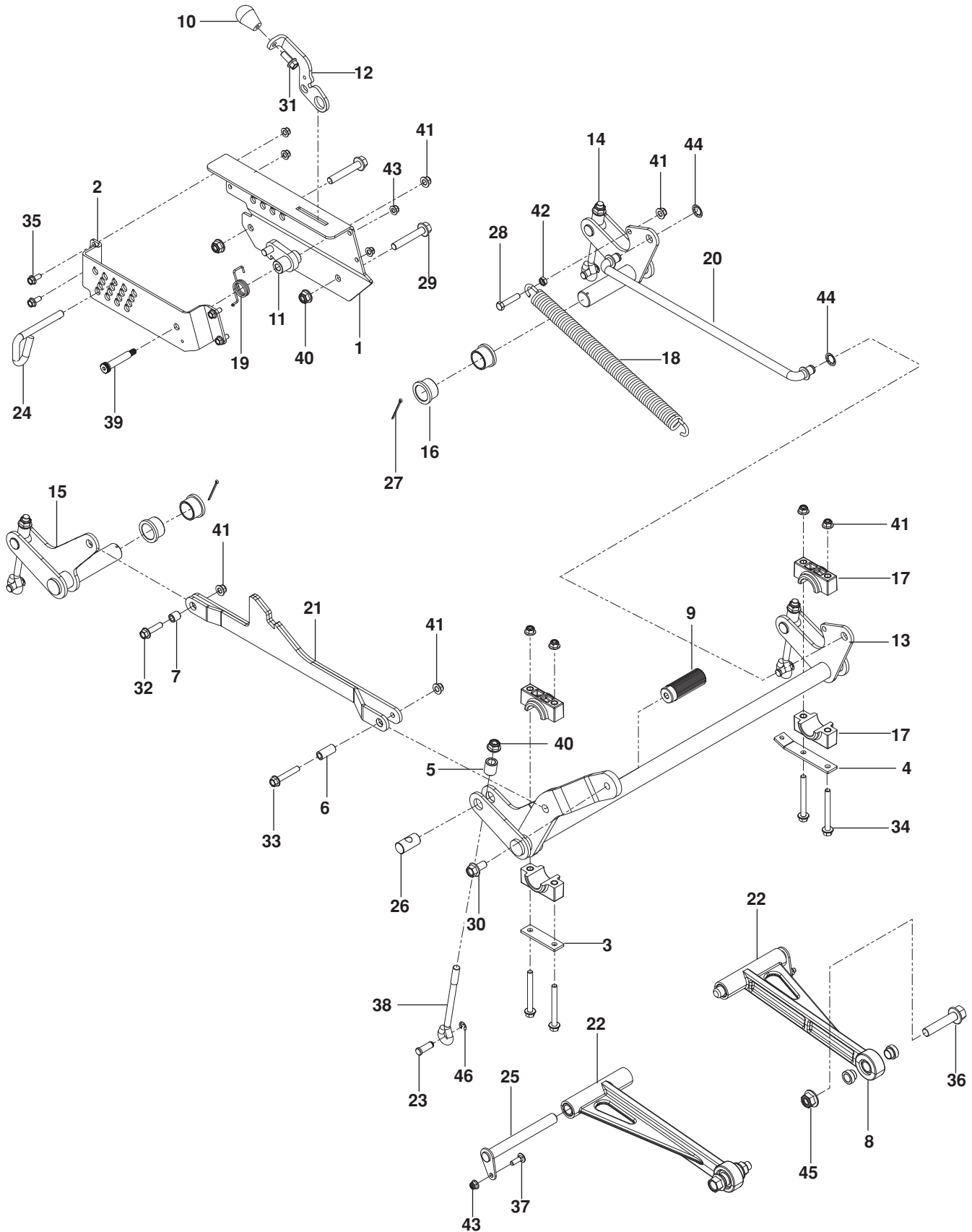

MOWER LIFT / DECK LIFT

ITEM	PART NO.	QTY.	DESCRIPTION	ITEM	PART NO.	QTY.	DESCRIPTION
1..	576 48 00-02.....	1	PLATE, HEIGHT, INNER ORG	24..	510 01 65-01.....	1	PIN, HEIGHT
2..	576 48 01-02.....	1	PLATE, HEIGHT, OUTER ORG	25..	515 98 82-01.....	2	PIN, STRUT
3..	525 82 22-01.....	1	PLATE, PILLOW BLOCK	26..	576 48 56-01.....	4	PIN, TRUNION
4..	576 64 67-01.....	1	PLATE, SPRING ANCHOR	27..	539 10 28-89.....	2	PIN 1/8 x 2 COTTER
5..	576 48 58-01.....	4	SPACER, EYEBOLT	28..	539 99 07-30.....	1	BOLT 3/8-16 x 1 3/4 HEX HD
6..	576 62 31-01.....	1	SPACER, FRT LIFT STRAP	29..	874 49 08-48.....	2	BOLT 1/2-13 x 3 HEX FLG HD
7..	576 62 30-01.....	1	SPACER, RR LIFT STRAP	30..	574 21 06-01.....	1	BOLT 1/2-13 x 1 HEX FLG HD
8..	510 36 25-01.....	4	SPACER, STRUT	31..	525 61 28-01.....	1	BOLT 3/8-16 x 1 HEX FLG HD
9..	510 40 83-01.....	1	PEDAL, DECK HEIGHT	32..	576 62 16-01.....	1	BOLT 3/8-16 x 1 1/2 HEX FLG HD
10..	539 13 26-24.....	1	KNOB	33..	874 49 06-36.....	1	BOLT 3/8-16 x 2 1/4 HEX FLG HD
11..	510 40 68-01.....	1	LATCH, TRANSPORT	34..	874 49 06-52.....	4	BOLT 3/8-16 x 3 1/2 HEX FLG HD
12..	576 63 89-01.....	1	LEVER, RELEASE	35..	874 49 05-12.....	4	BOLT 5/16-18 x 3/4 HEX FLG HD
13..	576 47 92-01.....	1	SHAFT, DECK LIFT FT	36..	874 45 10-48.....	2	BOLT 5/8-11 x 3 HEX FLG HD GR 8
14..	576 47 99-01.....	1	SHAFT, LIFT LT RR	37..	539 99 02-08.....	2	BOLT 5/16-18 x 1 RD HD SQNK
15..	576 47 94-01.....	1	SHAFT, LIFT RT RR	38..	576 47 90-01.....	4	EYEBOLT, DECK LIFT
16..	510 08 94-01.....	4	BUSHING, FLANGED	39..	516 03 55-01.....	1	BOLT 3/8-16 x 2 1/4 SHLDR
17..	510 02 39-02.....	4	BLOCK, PILLOW	40..	521 99 11-01.....	6	NUT 1/2-13 HEX FLG NYLOC
18..	576 67 66-01.....	1	SPRING, EXTENSION	41..	521 99 65-01.....	8	NUT 3/8-16 HEX FLG NYLOC
19..	510 37 66-01.....	1	SPRING, TORSION	42..	539 10 93-32.....	1	NUT 3/8-16 HEX JAM
20..	510 08 98-01.....	1	ROD, LIFT	43..	539 11 28-99.....	6	NUT 5/16-18 HEX FLG NYLOC
21..	576 62 26-01.....	1	STRAP, DECK	44..	539 10 93-04.....	2	NUT 5/8 PUSH
22..	510 10 65-01.....	2	STRUT ASSY	45..	525 82 91-01.....	2	NUT 5/8-11 FLG NYLOC
23..	510 09 01-01.....	4	PIN 7/16 CLEVIS	46..	522 70 52-01.....	4	E RING 7/16

MOWER DECK / CUTTING DECK

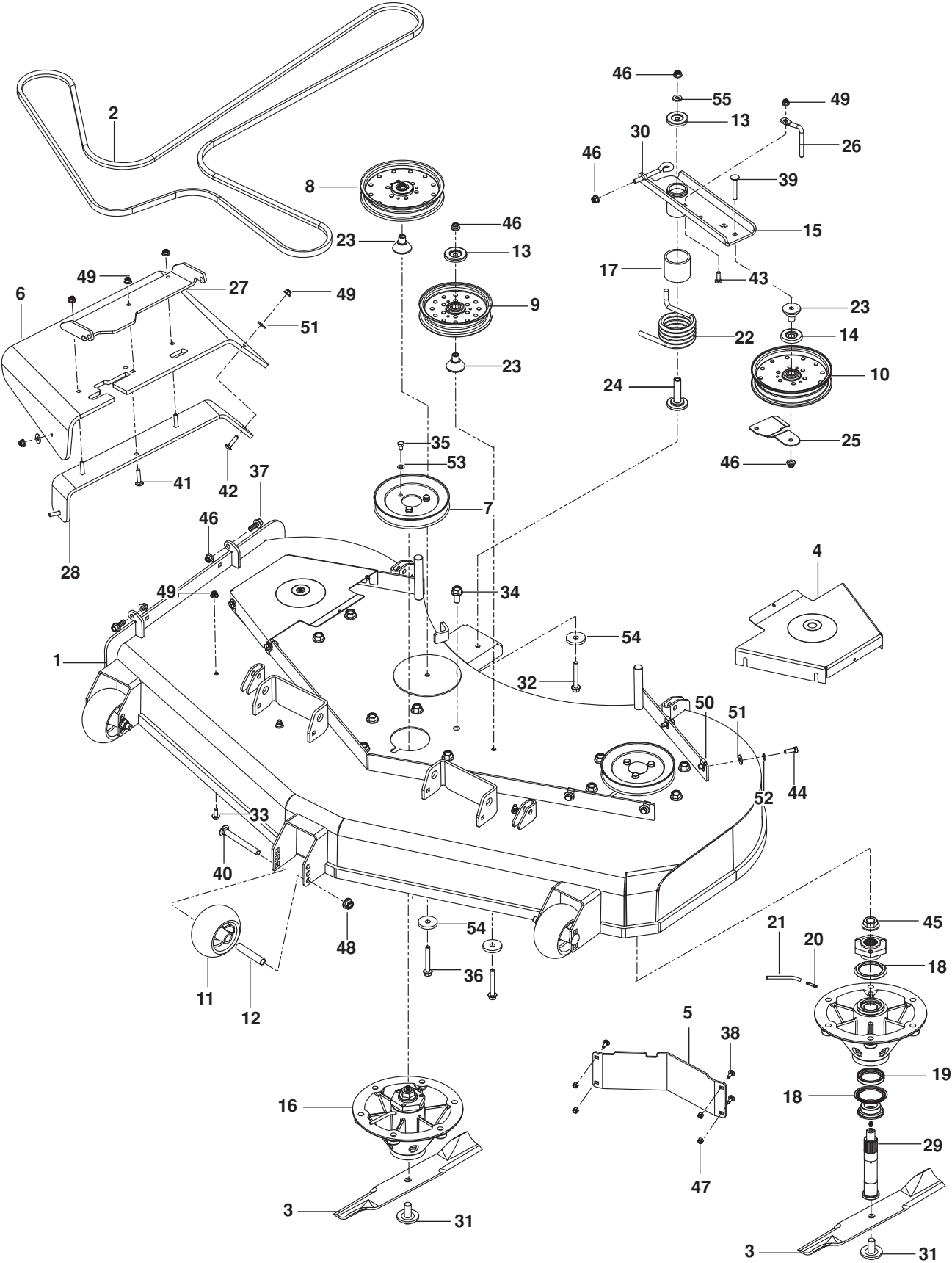

MOWER DECK / CUTTING DECK

ITEM	PART NO.	QTY.	DESCRIPTION	ITEM	PART NO.	QTY.	DESCRIPTION
1..	581 49 78-02.....	1	DECK w/ SAFETY DECALS	29..	580 94 21-01.....	3	SHAFT
2..	575 65 84-01.....	1	BELT	30..	574 20 20-01.....	1	EYE BOLT
3..	581 05 55-02.....	3	BLADE	31..	539 11 90-07.....	3	BLADE BOLT
4..	510 13 12-02.....	2	BELT SHIELD	32..	874 88 06-72.....	1	BOLT 3/8-16 x 4 1/2 HEX HD
5..	510 43 75-02.....	1	BAFFLE DIVERTER LT	33..	874 49 05-12.....	4	BOLT 5/16-18 x 3/4 HEX FLG HD
6..	525 48 58-01.....	1	CHUTE, DISCHARGE	34..	574 21 06-01.....	18	BOLT 1/2-13 x 1 HEX FLG HD
7..	521 97 97-01.....	3	PULLEY	35..	539 13 03-15.....	9	BOLT 5/16-18 x 1/2 HX HD
8..	525 59 82-01.....	1	PULLEY, IDLER 7" NARROW	36..	539 13 17-81.....	2	BOLT 3/8-16 x 2 3/4 HEX FLG HD
9..	510 01 96-01.....	1	PULLER, IDLER 6" NARROW	37..	525 61 28-01.....	2	BOLT WSH HEAD 3/8-16 x 1
10..	510 01 51-01.....	1	PULLEY, IDLER 7"	38..	539 11 56-20.....	4	BOLT 1/4-20 x 3/4 CARRIAGE
11..	574 16 96-01.....	3	ROLLER, GAUGE	39..	539 12 81-01.....	1	BOLT 3/8-16 x 2 1/2 CARRIAGE
12..	574 19 64-01.....	2	TUBE ROLLER AXLE	40..	510 02 23-01.....	2	BOLT 1/2-13 x 4 3/4 RD HD SQNK
13..	510 25 45-01.....	3	SHIELD DUST	41..	539 10 29-33.....	3	BOLT 5/16-18 x 1 1/2 RD HD SQNK
14..	510 26 22-01.....	1	SHIELD, DUST	42..	539 10 04-72.....	2	BOLT 5/16-18 x 1 1/4 RD HD SQNK
15..	525 46 44-03.....	1	ARM, IDLER w/ SPCR, BRGS	43..	872 11 05-08.....	1	BOLT 5/16-18 x 1 RD HD SQNK
16..	580 94 33-01.....	3	SPINDLE ASSY	44..	874 78 05-16.....	8	SCREW 5/16-18 x 1 HEX
17..	525 46 56-01.....	1	SPACER, IDLER PIVOT	45..	539 13 06-53.....	3	NUT 3/4-16 FLANGE
18..	580 94 27-01.....	6	SEAL, V-RING	46..	521 99 65-01.....	5	NUT 3/8-16 HEX FLG NYLOC
19..	580 94 26-01.....	6	SEAL, SHAFT	47..	539 97 69-78.....	4	NUT 1/4-20 HEX NYLOC
20..	580 94 30-01.....	3	ADAPTER	48..	521 99 11-01.....	2	NUT 1/2-13 HEX FLG NYLOC
21..	582 94 31-01.....	3	TUBE	49..	539 11 28-99.....	9	NUT 5/16-18 HEX FLG NYLOC
22..	525 31 09-01.....	1	SPRING, TORSION, IDLER	50..	539 10 47-63.....	8	RETAINER, U TYPE
23..	510 26 37-01.....	3	BEARING, IDLER ARM	51..	819 12 14-14.....	10	WASHER 5/16 STD FLT
24..	522 72 97-01.....	1	BEARING, IDLER PIVOT	52..	810 03 05-00.....	8	WASHER 5/16 SLW
25..	574 26 21-02.....	1	BELT GUIDE, BLK	53..	539 10 96-00.....	9	WASHER 5/16 DISC SPRING
26..	574 26 22-01.....	1	BELT KEEPER	54..	539 10 65-04.....	3	WASHER, HEAVY
27..	574 19 70-02.....	1	BRACKET, CHUTE PIVOT BLK	55..	522 02 34-01.....	1	WASHER 3/8 THICK
28..	525 48 60-02.....	1	SUPPORT, BRACKET BLK				

SEAT

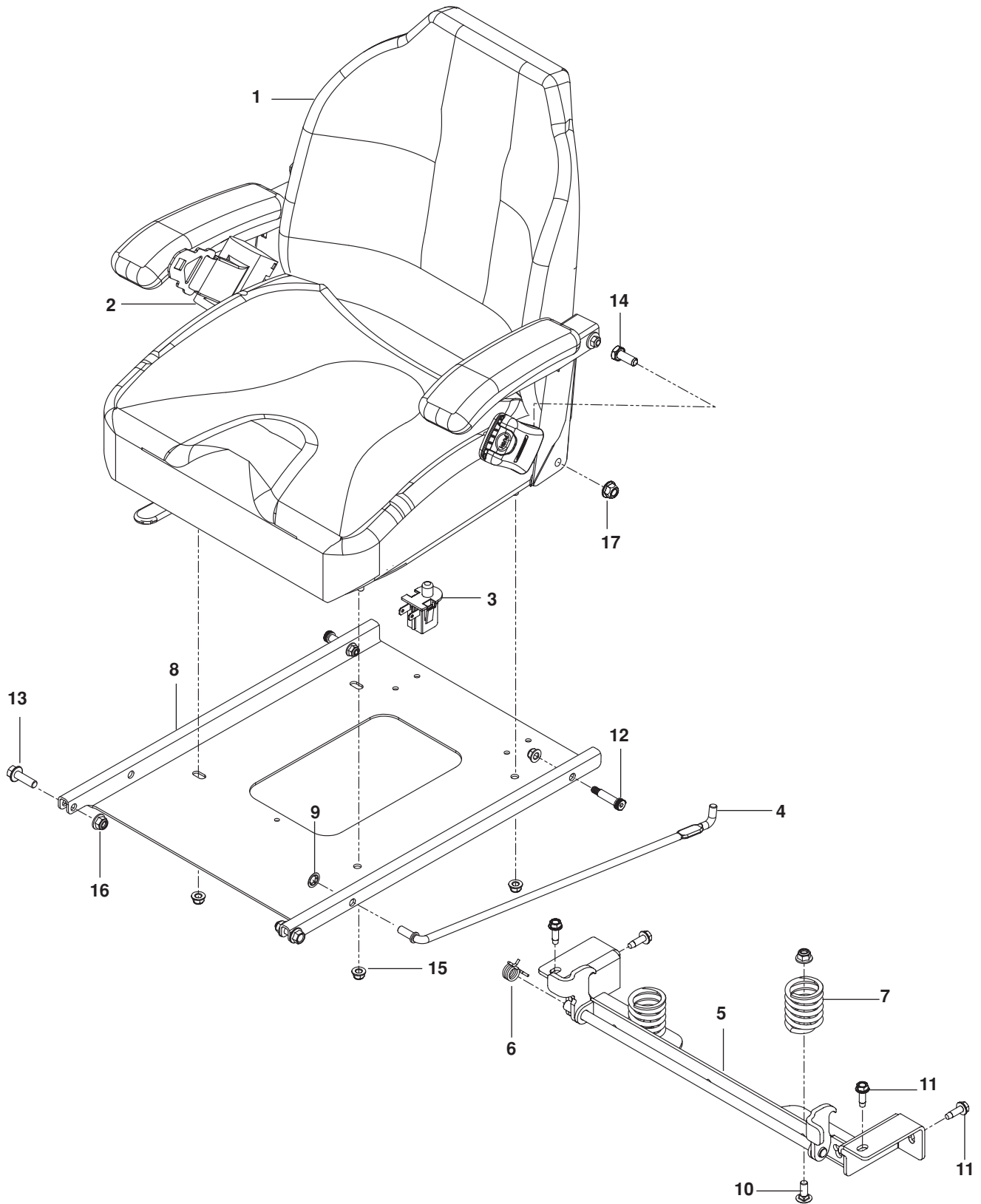

SEAT

ITEM	PART NO.	QTY.	DESCRIPTION	ITEM	PART NO.	QTY.	DESCRIPTION
1..	576 70 20-01.....	1	SEAT ASSY	10..	539 99 06-45.....	2	BOLT $\frac{3}{8}$ -16 x 1 RD HD SQNK
2..	576 78 34-01.....	1	SEAT BELT ASSY	11..	539 11 32-26.....	4	BOLT $\frac{5}{16}$ -18 x 1 THD FRM
3..	539 11 97-41.....	1	SWITCH, SEAT	12..	515 99 06-01.....	2	BOLT $\frac{3}{8}$ x $1\frac{1}{4}$ $\frac{5}{16}$ -18 SHLDR
4..	510 06 41-01.....	1	ROD, SEAT	13..	525 83 42-01.....	2	BOLT $\frac{3}{8}$ -16 x $1\frac{1}{4}$ HEX FLG HD
5..	585 85 74-02.....	1	LATCH, SEAT	14..	539 10 01-43.....	2	BOLT $\frac{7}{16}$ -14 x 1 HEX HD
6..	520 28 31-01.....	1	SPRING, TORSION	15..	539 11 28-99.....	6	NUT $\frac{5}{16}$ -18 HEX FLG NYLOC
7..	539 11 03-00.....	2	SPRING, SEAT	16..	521 99 65-01.....	2	NUT $\frac{3}{8}$ -16 HEX FLG NYLOC
8..	510 03 93-02.....	1	PAN, SEAT	17..	539 13 20-19.....	2	NUT $\frac{7}{16}$ -14 WHZ LK
9..	539 91 38-47.....	2	RETAINER $\frac{3}{8}$ NUT				

DECALS

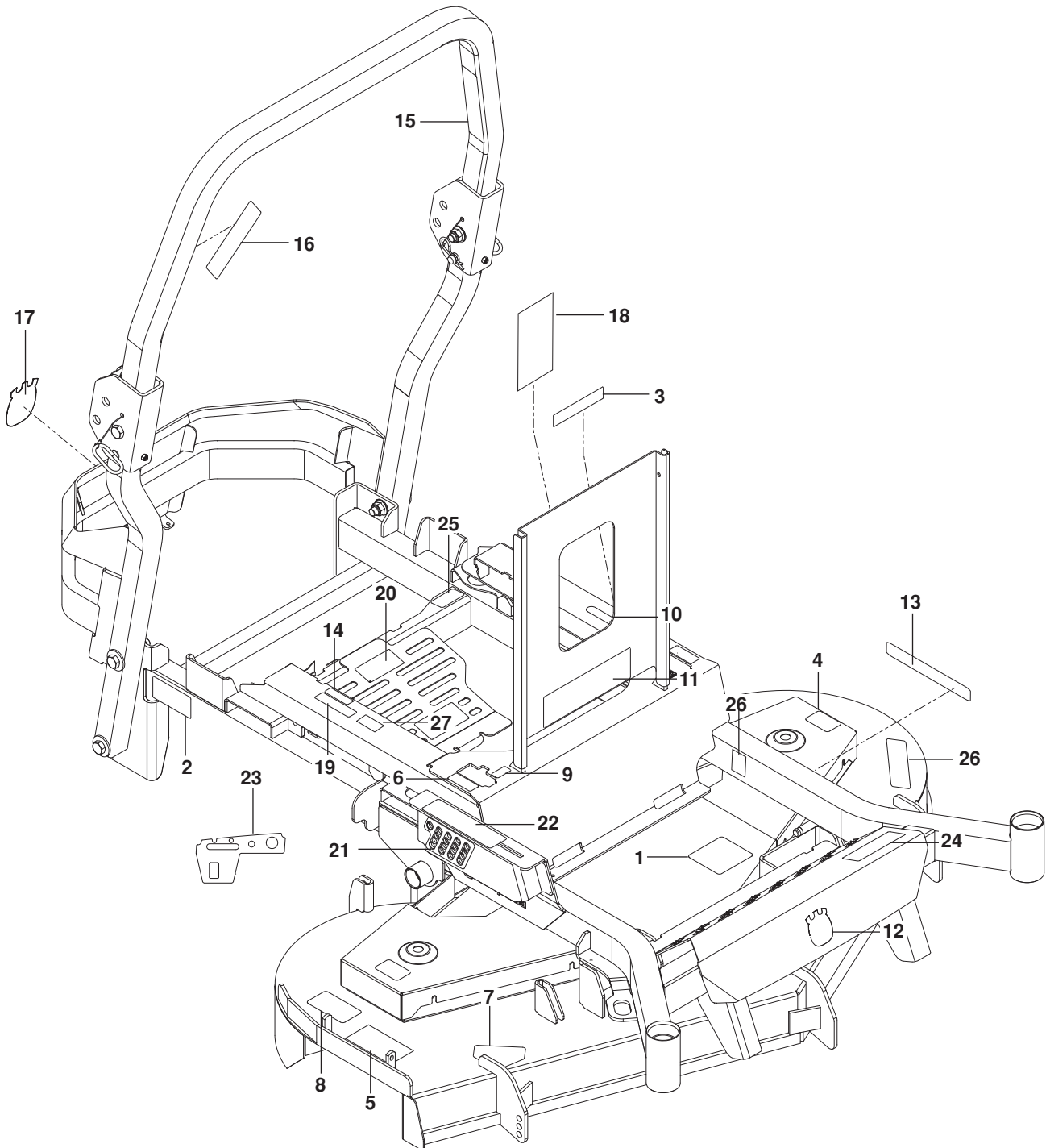

DECALS

ITEM	PART NO.	QTY.	DESCRIPTION
1..	574 43 73-01.....	1	DECAL, BELT ROUTE
2..	539 10 57-44.....	1	DECAL, BELT DRIVE WARN
3..	539 10 57-45.....	1	DECAL, BATTERY WARNING
4..	581 72 43-01.....	2	DECAL, NO STEP
5..	539 10 57-46.....	1	DECAL, SEVERING
6..	539 10 33-33.....	2	DECAL, MOTION CONTROL
7..	584 90 46-01.....	1	DECAL, BLADE WARNING
8..	581 72 44-01.....	1	DECAL, DEFLECTOR
9..	539 11 09-74.....	2	DECAL, TRACKING
10..	539 12 00-06.....	1	DECAL, PARK BRAKE
11..	539 10 79-59.....	1	DECAL, WARNING
12..	532 42 86-76.....	1	DECAL, CROWN H SM
13..	532 42 91-96.....	2	DECAL, HUSQVARNA
14..	574 56 94-01.....	1	DECAL, FUSE

ITEM	PART NO.	QTY.	DESCRIPTION
15..	574 56 90-06.....	1	DECAL, ROPS
16..	574 56 90-02.....	1	DECAL, ROPS WARNING
17..	574 45 50-01.....	1	DECAL, CROWN LG
18..	574 82 59-01.....	1	DECAL, SERVICE
19..	532 42 41-02.....	1	DECAL, SPARK ARRESTOR
20..	574 81 55-01.....	1	DECAL, ZT-3400
21..	576 75 53 01.....	1	DECAL, HEIGHT
22..	576 76 38-01.....	1	DECAL, RELEASE LEVER
23..	510 24 66-02.....	1	DECAL, CONTROL
24..	576 75 52 07.....	1	DECAL, P-ZT54
25..	577 15 01-01.....	1	DECAL, FUEL
26..	581 72 41-02.....	1	DECAL, DB80
27..	539 11 02-79.....	1	DECAL, ECM AUSTRALIA
28..	539 12 13-22.....	1	FOOT PAD

PROTECTION FRAME

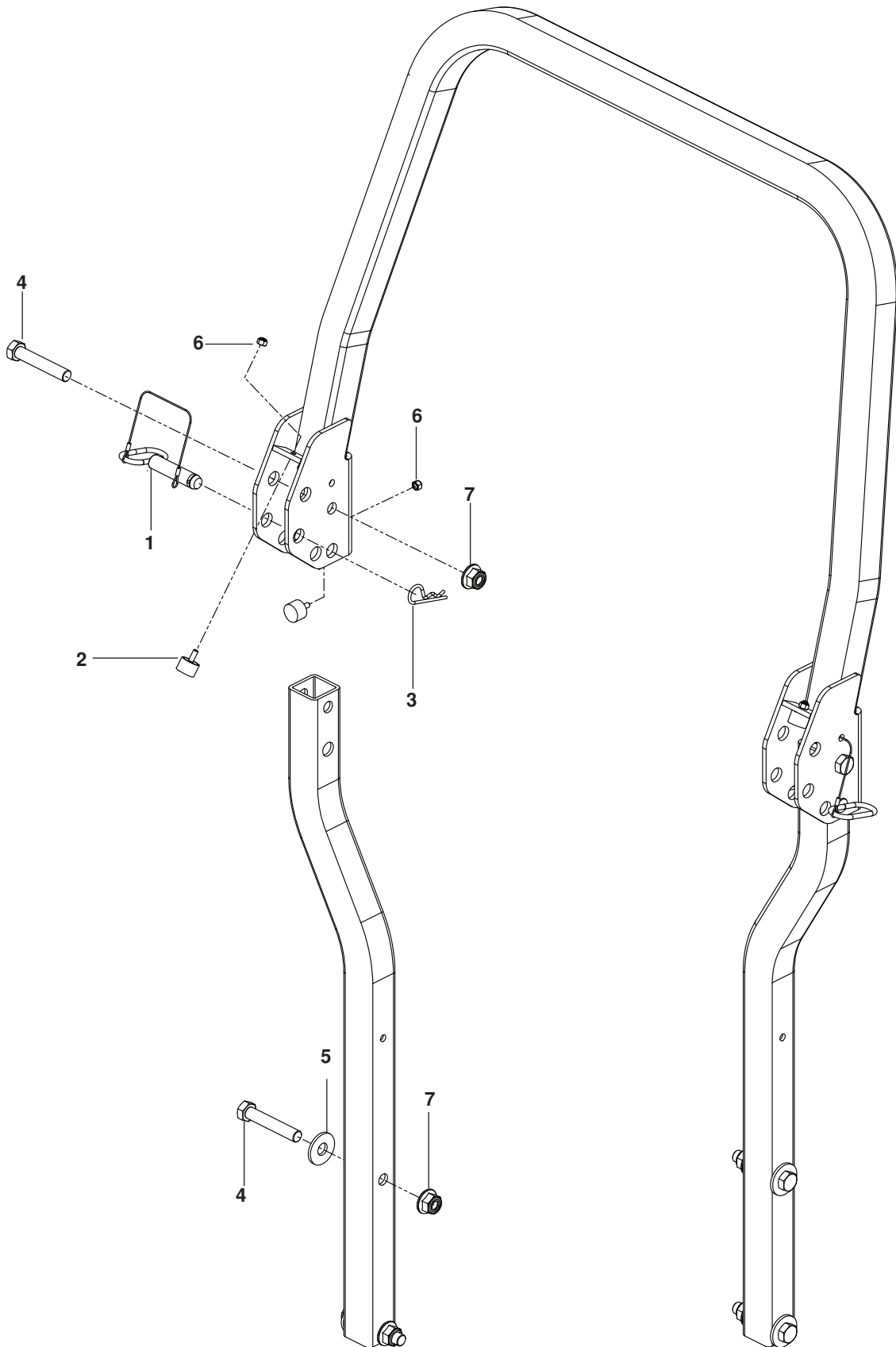

PROTECTION FRAME

ITEM	PART NO.	QTY.	DESCRIPTION	ITEM	PART NO.	QTY.	DESCRIPTION
1..	574 38 80-01.....	2.....	LATCH PIN w/ LANYARD	5..	539 10 26-53.....	4.....	WASHER ⁵ / ₈ STD FLAT
2..	522 80 14-01.....	4.....	BUMPER, MALE STUD ¹ / ₄ -20	6..	873 80 04-00.....	4.....	NUT ¹ / ₄ -20 HEX NYLOC
3..	539 20 07-15.....	2.....	PIN, HAIR	7..	525 82 91-01.....	6.....	NUT ⁵ / ₈ -11 FLG NYLOC
4..	580 75 46-01.....	6.....	BOLT ⁵ / ₈ -11 x 3 ¹ / ₂ HEX HD				

ACCESSORIES

BLOWER

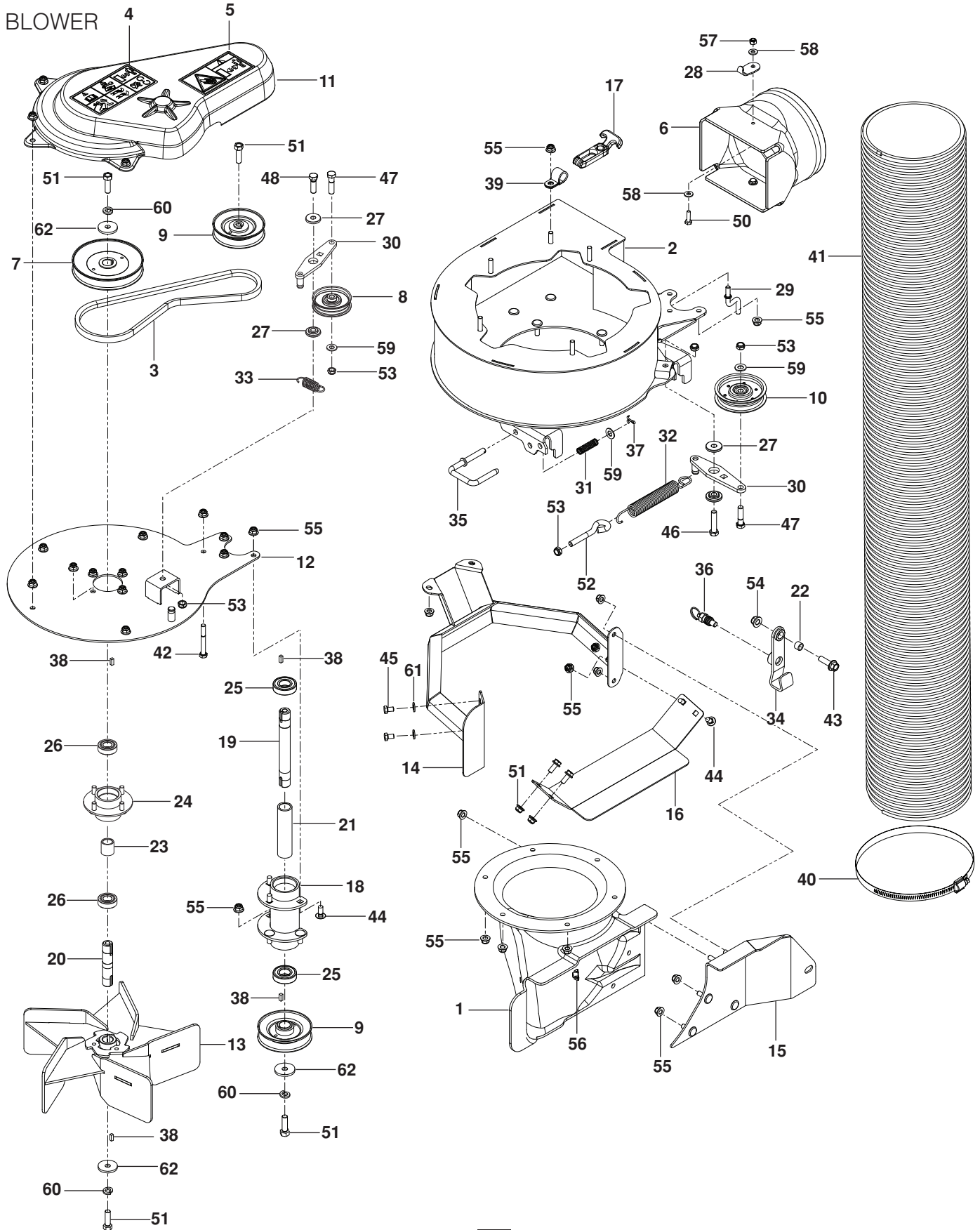

ACCESSORIES

ITEM	PART NO.	QTY.	DESCRIPTION	ITEM	PART NO.	QTY.	DESCRIPTION
1..	522 59 33-01.....	1	HOUSING, BLOWER LOWER	32..	532 19 61-05.....	1	SPRING, DECK DRIVE
2..	585 85 60-02.....	1	HOUSING, BLOWER UPPER	33..	522 59 51-01.....	1	SPRING, IDLER
3..	539 10 13-86.....	1	BELT	34..	585 37 65-01.....	1	LATCH, RR LOWER
4..	539 10 57-85.....	1	DECAL, WARNING	35..	586 08 22-01.....	2	PIN, LATCH
5..	539 10 67-41.....	1	DECAL, IMPELLER	36..	585 37 68-01.....	1	PIN, SPRING
6..	585 23 68-02.....	1	CONNECTOR, HOSE	37..	539 97 68-99.....	2	PIN, COTTER 1/8 x 3/4
7..	539 13 03-24.....	1	PULLEY	38..	539 11 56-67.....	4	KEY 3/16 x 1/2
8..	539 10 67-21.....	1	PULLEY, IDLER	39..	539 10 26-85.....	2	CLAMP, TUBE
9..	522 59 46-01.....	2	PULLEY, DRIVE	40..	574 38 66-01.....	1	CLAMP, HOSE
10..	579 60 46-01.....	1	PULLEY, IDLER	41..	578 25 79-01.....	1	HOSE
11..	585 37 38-01.....	1	SHIELD, BELT TOP	42..	874 78 05-40.....	1	BOLT 5/16-18 x 2 1/2
12..	585 37 46-02.....	1	PLATE, TOP BLK	43..	525 83 42-01.....	1	BOLT 3/8-16 x 1 1/4 HEX FLANGE
13..	585 58 78-01.....	1	IMPELLER	44..	872 14 05-06.....	7	BOLT 5/16-18 x 3/4 RD HD SQNK
14..	585 37 57-02.....	1	GUARD, BLK	45..	874 78 05-08.....	2	BOLT 5/16-18 x 1/2
15..	585 37 62-02.....	1	BRACKET, BLOWER RR BLK	46..	539 97 69-49.....	1	BOLT 3/8-16 x 1 3/4
16..	585 37 64-02.....	1	SKID PLATE, BLK	47..	874 78 06-24.....	2	BOLT 3/8-16 x 1 1/2
17..	586 18 47-01.....	2	LATCH, DRAW T-HANDLE	48..	874 78 06-20.....	1	BOLT 3/8-16 x 1 1/4
18..	522 59 50-01.....	1	TUBE, SPINDLE	49..	874 49 05-12.....	1	BOLT 5/16-18 x 3/4
19..	585 37 54-01.....	1	SHAFT, SPINDLE	50..	539 99 06-43.....	2	SCREW 1/4-20 x 7/8 HEX CAP
20..	585 37 56-01.....	1	SHAFT, IMPELLER	51..	532 85 08-57.....	4	SCREW 3/8-24 x 1 1/4 HEX HD
21..	585 37 55-01.....	1	SPACER	52..	539 10 74-84.....	1	EYEBOLT 3/8-16 x 2 1/4 SPEC
22..	579 61 33-01.....	1	SPACER	53..	539 20 02-82.....	5	NUT 3/8-16 HEX NYLON THIN
23..	585 37 53-01.....	1	SPACER	54..	521 99 65-01.....	1	NUT 3/8-16 HEX FLG NYLOC
24..	585 37 49-01.....	1	HOUSING, HUB	55..	539 11 28-99.....	38	NUT 5/16-18 HEX FLG NYLOC
25..	539 13 02-96.....	2	BEARING	56..	539 13 03-13.....	2	NUT 5/16-18 TEE
26..	585 37 52-01.....	2	BEARING	57..	539 97 69-78.....	2	NUT 1/4-20 HEX NYLOC
27..	539 13 21-61.....	4	BUSHING, BRAKE	58..	819 09 10-16.....	4	WASHER
28..	586 08 23-01.....	2	KEEPER, LATCH	59..	819 13 13-16.....	3	WASHER FLAT
29..	522 59 52-01.....	1	KEEPER, BELT	60..	810 03 06-00.....	4	WASHER LOCK HVY 3/8
30..	522 59 48-02.....	2	IDLER, BLK	61..	819 11 11-16.....	2	WASHER 16 GA
31..	525 81 60-01.....	1	SPRING, COMPRESSION	62..	532 14 02-96.....	4	WASHER, BLADE

ACCESSORIES

CLAMSHELL REAR

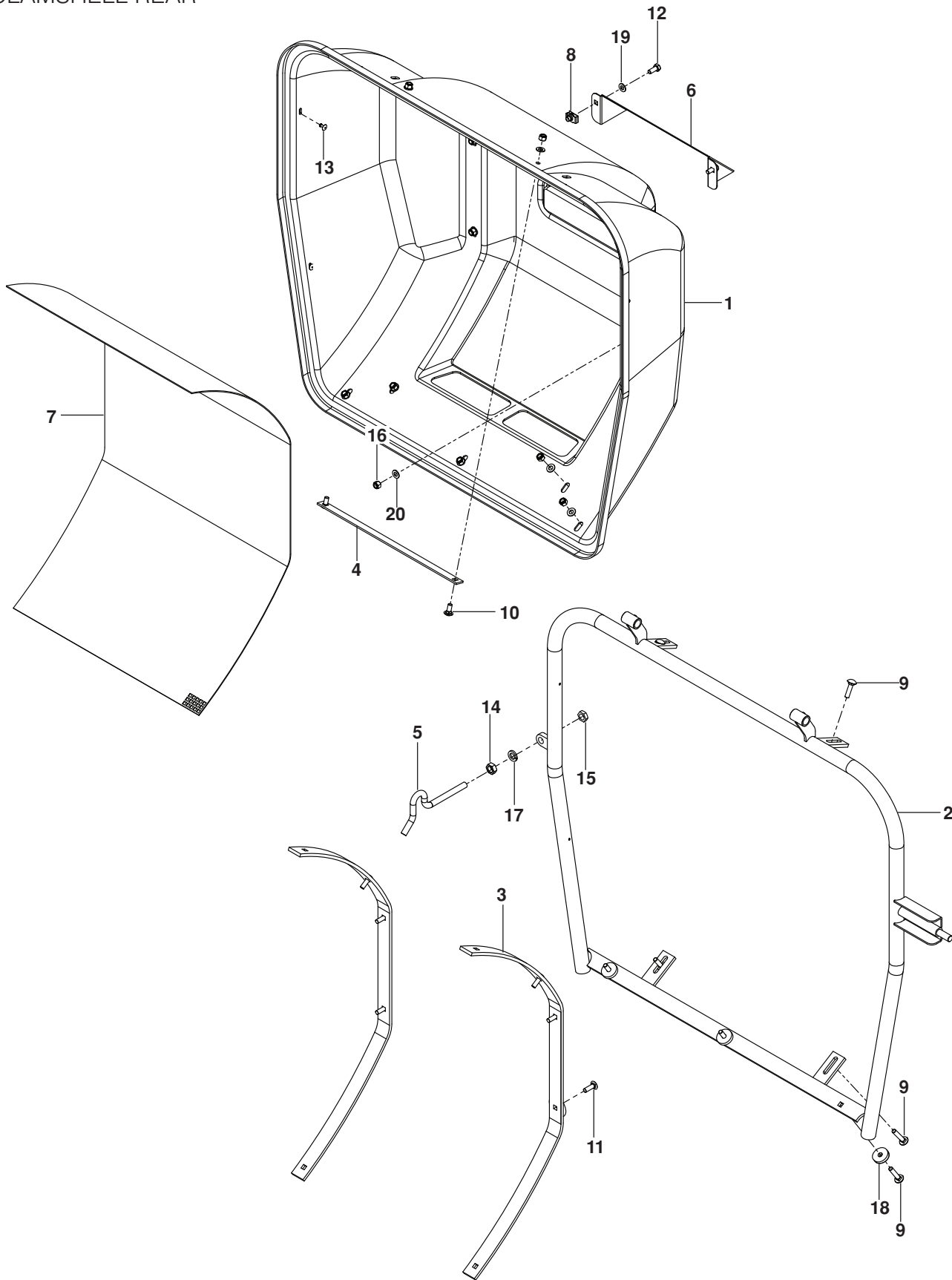

ACCESSORIES

ITEM	PART NO.	QTY.	DESCRIPTION	ITEM	PART NO.	QTY.	DESCRIPTION
1..	539 11 93-77.....	1	CLAMSHELL BACK	11..	539 10 72-71.....	6	BOLT $\frac{5}{16}$ 18 x 1 RD HD SQNK
2..	539 11 79-87.....	1	FRAME, REAR	12..	539 99 02-06.....	2	BOLT $\frac{5}{16}$ -18 x $\frac{3}{4}$
3..	539 11 93-96.....	2	STRAP	13..	539 11 94-13.....	6	RIVET
4..	539 11 94-58.....	1	STRAP	14..	539 11 56-09.....	1	NUT $\frac{1}{2}$ -13 THIN NYLOC
5..	539 11 93-67.....	1	HOOK LATCH	15..	539 99 06-25.....	1	NUT $\frac{1}{2}$ -13 HEX JAM
6..	539 11 75-43.....	1	VENT, CLAMSHELL	16..	539 99 07-17.....	15	NUT $\frac{5}{16}$ -18 NYLOC
7..	581 53 29-01.....	1	SCREEN, VENT	17..	539 99 02-54.....	1	WASHER $\frac{1}{2}$ LOCK
8..	539 11 56-77.....	2	RETAINER, U TYPE	18..	539 11 57-89.....	3	WASHER, NYLON
9..	539 10 04-72.....	7	BOLT $\frac{5}{16}$ -18 x $1\frac{1}{4}$ RD HD SQNK	19..	539 99 01-88.....	2	WASHER $\frac{5}{16}$ SAE
10..	539 99 03-16.....	2	BOLT $\frac{5}{16}$ -18 x $\frac{3}{4}$ RD HD SQNK	20..	539 99 06-92.....	15	WASHER $\frac{5}{16}$ STD

ACCESSORIES

CLAMSHELL FRONT

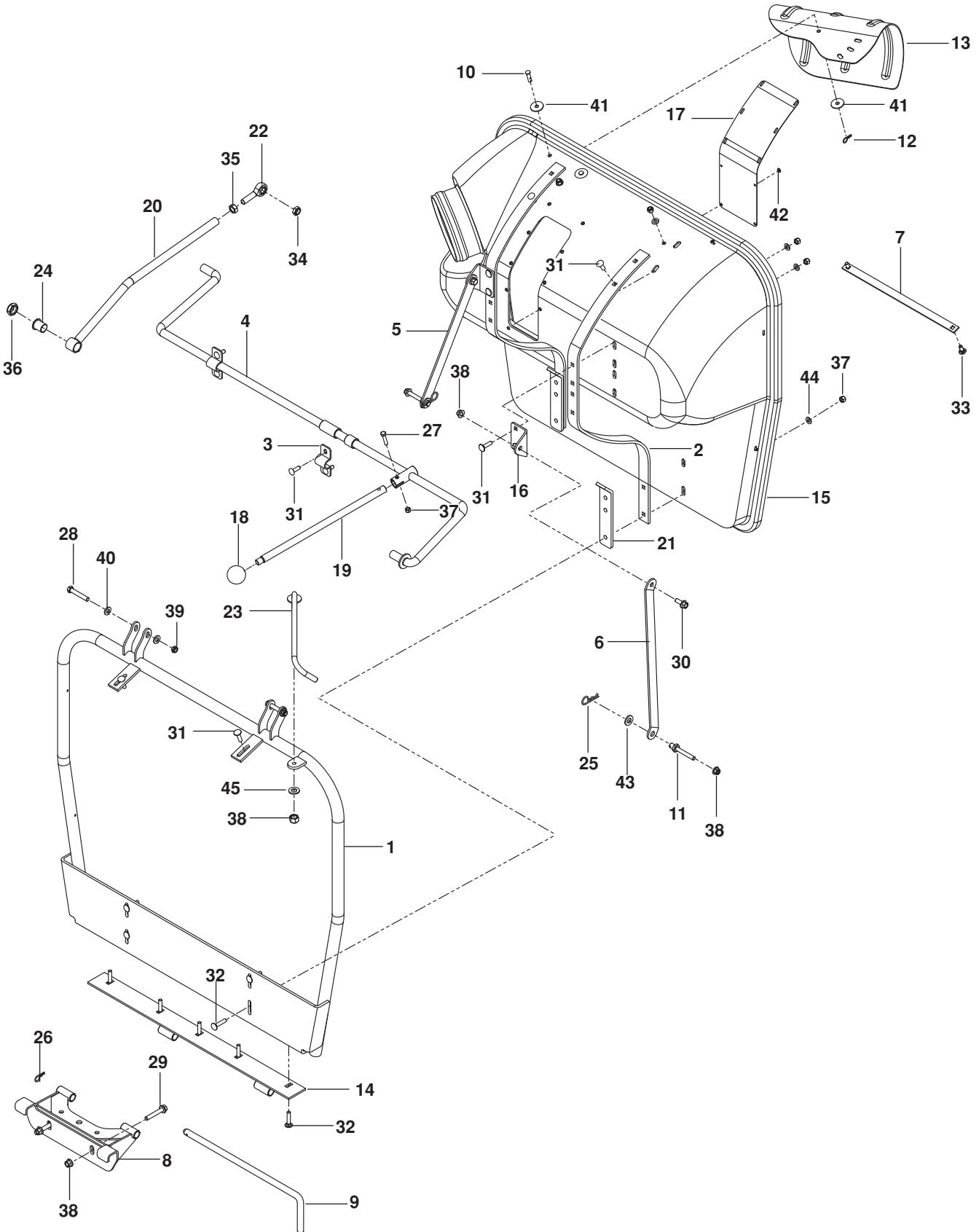

ACCESSORIES

ITEM	PART NO.	QTY.	DESCRIPTION	ITEM	PART NO.	QTY.	DESCRIPTION
1..	539 11 94-10.....	1	FRONT FRAME	24..	539 11 59-72.....	2	BUSHING
2..	539 11 94-09.....	2	STRAP	25..	539 97 69-89.....	2	HAIRPIN 2½
3..	539 11 93-68.....	2	STRAP	26..	539 11 55-01.....	1	HAIRPIN 1¾
4..	580 98 00-01.....	1	SHAFT, LIFT	27..	539 97 69-35.....	1	BOLT 5/16-18 x 1½
5..	580 97 95-02.....	1	STRAP, MOUNTING, LT BLK	28..	539 99 06-29.....	2	BOLT 3/8-18 x 2¼
6..	580 97 96-02.....	1	STRAP, MOUNTING, RT BLK	29..	577 09 83-01.....	2	BOLT 3/8-16 x 2¼ HEX FLG GR8
7..	539 11 94-58.....	1	STRAP	30..	525 61 28-01.....	2	BOLT 3/8-16 x 1 HEX FLG HD
8..	580 97 91-02.....	1	HITCH, BLK	31..	539 10 04-72.....	12	BOLT 5/16-18 x 1¼ RDHD SQNK
9..	539 11 93-72.....	1	PIN, HINGE	32..	539 10 29-33.....	9	BOLT 5/16-18 x 1½ RDHD SQNK
10..	539 11 55-96.....	2	PIN 5/16 CLEVIS	33..	539 99 03-16.....	2	BOLT 5/16-18 x ¾ RDHD SQNK
11..	525 44 50-01.....	2	PIN, MOUNT	34..	539 10 80-10.....	1	NUT ½-13 THIN NYLOC
12..	532 00 49-39.....	2	PIN, RETAINER	35..	539 10 87-63.....	1	NUT ½-20 JAM
13..	539 11 94-33.....	1	DEFLECTOR	36..	522 84 26-01.....	1	NUT ¾-16 THIN NYLOC
14..	539 11 47-79.....	1	MOUNT, LOWER	37..	539 99 07-17.....	23	NUT 5/16-18 NYLOC
15..	580 97 83-01.....	1	CLAMSHELL, FRONT	38..	521 99 65-01.....	6	NUT 3/8-16 HEX FLG NYLOC
16..	580 97 97-02.....	2	BRACKET, MOUNTING	39..	539 20 02-82.....	2	NUT 3/8-16 HEX JAM NYLOC
17..	539 11 54-41.....	1	WINDOW	40..	539 99 01-22.....	4	WASHER 3/8 SAE FLT
18..	580 98 06-01.....	1	KNOB, BLK	41..	539 11 54-95.....	4	WASHER 11/32
19..	580 98 05-01.....	1	ARM, DUMP	42..	539 11 00-33.....	10	WASHER
20..	539 11 48-16.....	1	ARM, LIFT	43..	539 99 02-50.....	2	WASHER, SAE
21..	539 11 79-88.....	2	PLATE, SPACER	44..	539 99 06-92.....	23	WASHER 5/16 STD
22..	539 11 72-44.....	1	ROD END	45..	539 99 01-88.....	1	WASHER 5/16 SAE
23..	539 11 48-16.....	1	LINKAGE, LATCH				

ACCESSORIES

WEIGHTS, GUARDS, BLADES

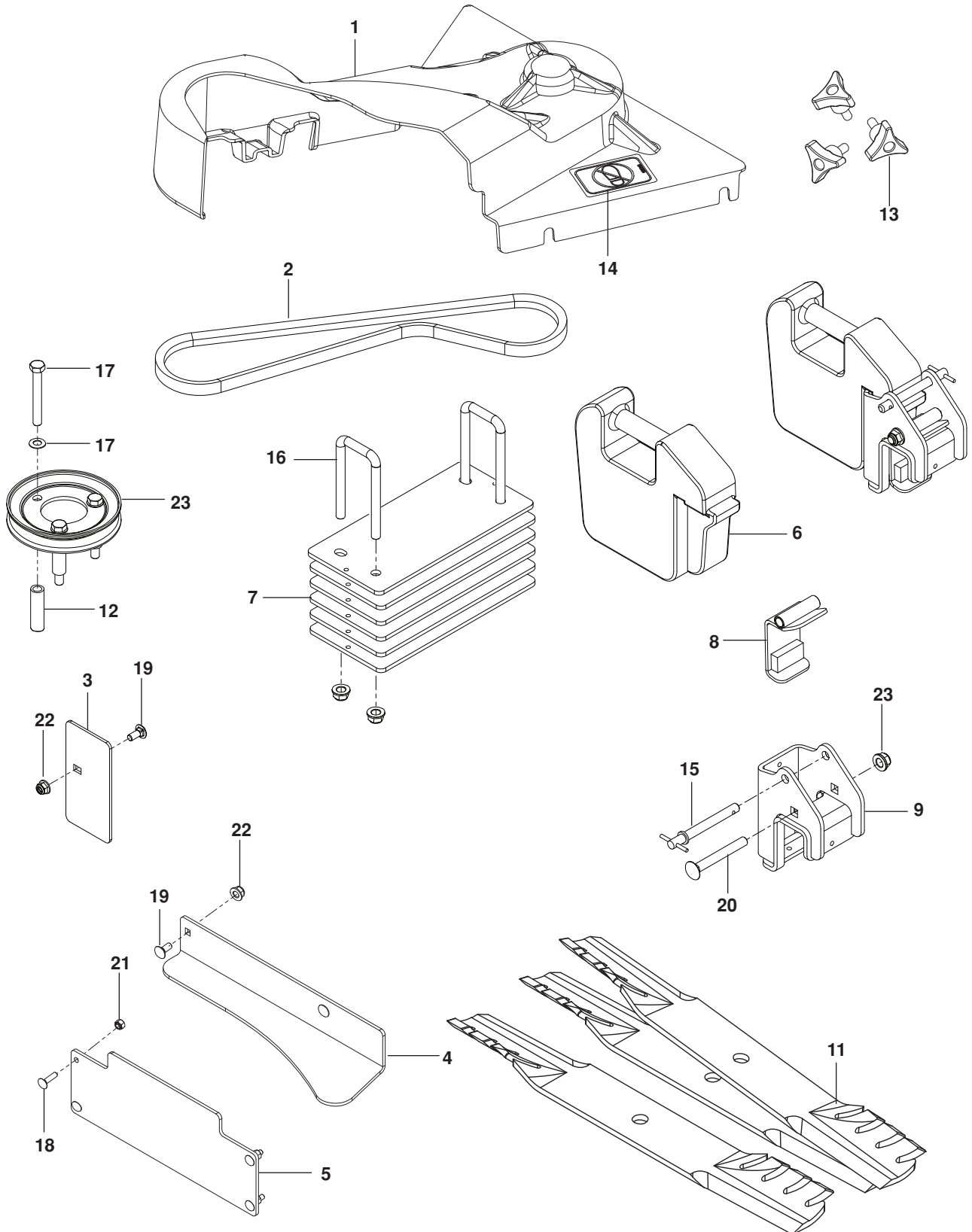

ACCESSORIES

ITEM	PART NO.	QTY.	DESCRIPTION	ITEM	PART NO.	QTY.	DESCRIPTION
1..	522 59 58-02.....	1	SHIELD, BELT, 54"	13..	539 10 44-11.....	3	KNOB w/ STUD
2..	539 10 04-39.....	1	BELT, BLOWER 54"	14..	539 10 57-43.....	1	DECAL, NO STEP
3..	525 79 87-01.....	1	PLATE, BLOCK OFF	15..	575 50 99-01.....	2	PIN, DETENT
4..	575 59 41-02.....	1	BAFFLE, RT	16..	575 88 06-01.....	2	U BOLT
5..	575 59 36-02.....	1	BAFFLE, LT	17..	539 99 10 46.....	3	BOLT $\frac{5}{16}$ -18 x 2 $\frac{1}{2}$
6..	539 09 25-31.....	2	WEIGHT CAST, FRONT	18..	539 10 98-00.....	4	BOLT $\frac{1}{4}$ -20 x 1 RD HD SQNK
7..	575 88 05-01.....	6	WEIGHT PLATE	19..	539 99 03-16.....	3	BOLT $\frac{5}{16}$ -18 x $\frac{3}{4}$ RD HD SQNK
8..	575 50 95-01.....	2	LATCH	20..	539 10 84-84.....	2	BOLT $\frac{1}{2}$ -13 x 4 RD HD SQNK
9..	575 50 98-02.....	2	BRACKET, WEIGHT, BLK	21..	539 97 69-78.....	4	NUT $\frac{1}{4}$ -20 HEX NYLOC
10..	522 59 45-02.....	1	PULLEY, DRIVE 54"	22..	539 11 28-99.....	3	NUT $\frac{5}{16}$ -18 HEX FLG NYLOC
11..	525 52 59-01.....	3	BLADE, GATOR 54"	23..	521 99 11-01.....	6	NUT $\frac{1}{2}$ -13 HEX FLG NYLOC
12..	573 98 27-01.....	3	SPACER, PULLEY	24..	539 10 96-00.....	3	WASHER $\frac{5}{16}$ DISC SPRING

ACCESSORIES

MULCH KIT

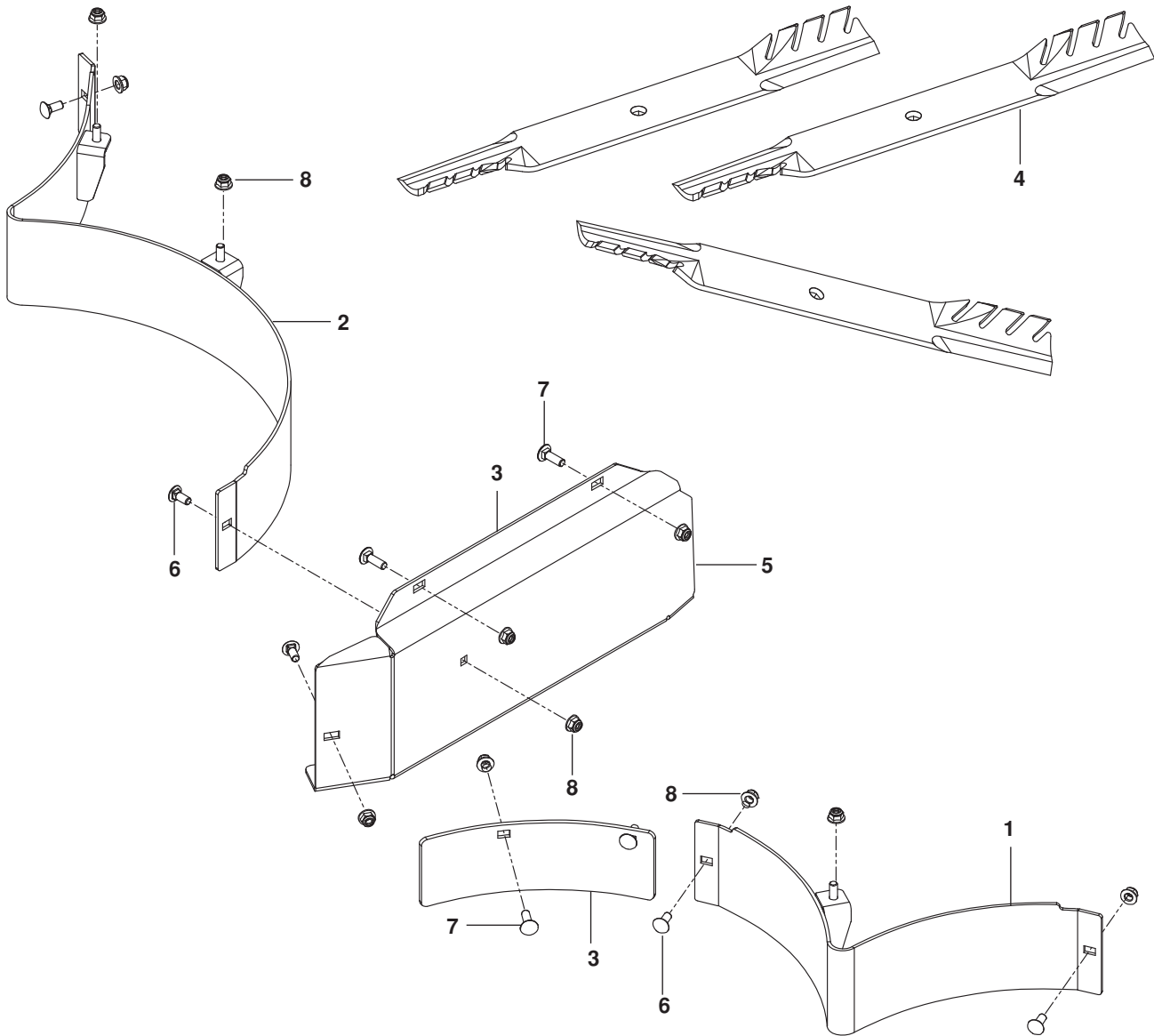

ITEM	PART NO.	QTY.	DESCRIPTION
------	----------	------	-------------

- | | | | |
|-----|-------------------|---|------------------------|
| 1.. | 525 52 54-02..... | 1 |BAFFLE, MULCH LH |
| 2.. | 525 52 55-02..... | 1 |BAFFLE, MULCH RH |
| 3.. | 525 52 58-02..... | 1 |BAFFLE, LH CORNER |
| 4.. | 525 52 59-01..... | 3 |BLADE, 19" GATOR |

ITEM	PART NO.	QTY.	DESCRIPTION
------	----------	------	-------------

- | | | | |
|-----|-------------------|----|---|
| 5.. | 525 53 39-02..... | 1 |CAP, MULCH |
| 6.. | 539 99 03-16..... | 5 |BOLT $\frac{5}{16}$ -18 x $\frac{3}{4}$ RD HD SQNK |
| 7.. | 539 99 02-08..... | 4 |BOLT $\frac{5}{16}$ -18 x 1 RD HD SQNK |
| 8.. | 539 11 28-99..... | 12 |NUT $\frac{5}{16}$ -18 HEX FLG NYLOC |

www.husqvarna.com

115 72 09-28 Rev A
2014-08-01