

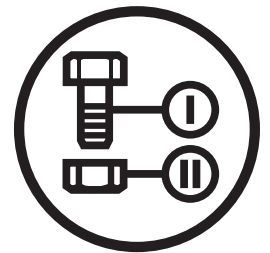

Parts Manual

RZ3016

Zero Turn Mower / 966612302-04



Please read the operator manual carefully and make sure you understand the instructions before using the machine.

When you need spare parts or support in service questions, warranty issues, etc., please consult the following professional:

This manual belongs to the machine with the manufacturing number:	Engine	Transmission

Manufacturing Number

The machine's manufacturing number can be found on the printed plate affixed to the engine compartment.

Stated on the plate, from the top are:

- The machine's type designation (I.D.).
- The manufacturer's type number (Model).
- The machine's serial number (Serial no.)

Please have the type designation and serial number available when ordering spare parts.

The engine's manufacturing number is stamped on one of the valve covers.

The plate states:

- The engine's model.
- The engine's type.
- Code

Please have these available when ordering spare parts.

The wheel motors and hydrostatic pumps have a barcode decal affixed at the rear.

Accessories Available

Collection System.....	966 47 69-01
Mulch Kit.....	960 17 00-25

CONTENTS

FRAME.....	4
ENGINE PLATE.....	6
STEERING	8
IGNITION SYSTEM.....	10
HYDRAULIC PUMP / MOTOR	12
WHEELS / TIRES	14
BRAKE / DECK LIFT	16
MOWER DECK / CUTTING DECK.....	18
SEAT	20
DECALS.....	22
ACCESSORIES	
BAGGER.....	24
MOUNTS, CHUTES, WEIGHTS	26
MULCH KIT	28

Illustrations may or may not represent the actual assemblies and it is not recommended to use this manual as a guide to assemble or disassemble the mower.

NOTE: All fasteners are Grade 5 unless otherwise specified.

FRAME

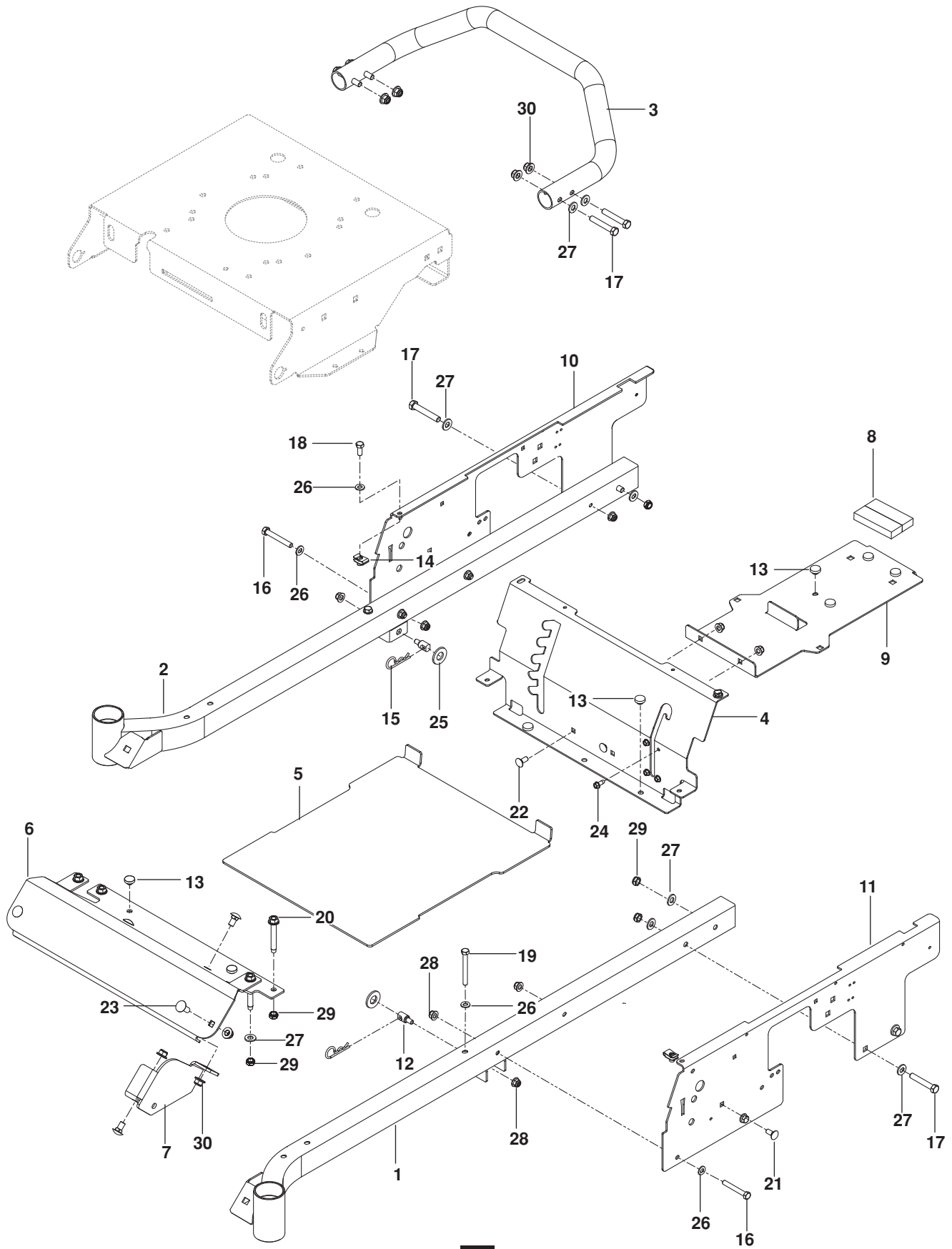

FRAME

ITEM	PART NO.	QTY.	DESCRIPTION	ITEM	PART NO.	QTY.	DESCRIPTION
1..	525 45 47-02.....	1	FRAME TUBE, LT ORG	16..	874 78 05-36.....	4	BOLT $\frac{5}{16}$ -18 x 2 $\frac{1}{4}$ HEX HD
2..	525 45 49-02.....	1	FRAME TUBE, RT ORG	17..	874 78 06-36.....	8	BOLT $\frac{3}{8}$ -16 x 2 $\frac{1}{4}$ HEX HD
3..	525 86 59-02.....	1	BAR, IMPACT ORG	18..	874 78 05-12.....	2	BOLT $\frac{5}{16}$ -18 x $\frac{3}{4}$ HEX HD
4..	575 85 21-02.....	1	PANEL, SEAT SUPPORT ORG	19..	874 78 05-44.....	2	BOLT $\frac{5}{16}$ -18 x 2 $\frac{3}{4}$ HEX HD
5..	576 45 24-01.....	1	FOOT PLATE w/DECALS ORG	20..	874 49 06-44.....	4	BOLT $\frac{3}{8}$ -16 x 2 $\frac{3}{4}$ HEX FLG HD
6..	525 83 59-02.....	1	FOOT REST ORG	21..	872 14 06-06.....	2	BOLT $\frac{3}{8}$ -16 x $\frac{3}{4}$ RD HD SQNK
7..	525 60 55-02.....	1	BRACKET, FRONT DECK BLK	22..	872 14 05-06.....	2	BOLT $\frac{5}{16}$ -18 x $\frac{3}{4}$ RD HD SQNK
8..	539 11 02-90.....	2	FOAM STRIP	23..	872 14 06-08.....	2	BOLT $\frac{3}{8}$ -16 x 1 RD HD SQNK
9..	525 79 84-02.....	1	SUPPORT, TANK BLK	24..	817 49 04-10.....	4	SCREW $\frac{1}{4}$ -20 x $\frac{5}{8}$ SLF TAP
10..	575 32 84-02.....	1	PLATE, RT ORG	25..	819 21 21-13.....	2	WASHER $\frac{5}{8}$ SAE FLT
11..	575 32 83-02.....	1	PLATE, LT ORG	26..	819 11 11-16.....	10	WASHER $\frac{5}{16}$ SAE FLT
12..	532 19 51-61.....	2	STUD w/ ANTI-ROTATE	27..	819 13 13-16.....	16	WASHER $\frac{3}{8}$ SAE FLT
13..	539 10 25-87.....	8	GROMMET, BUMPER	28..	539 11 28-99.....	4	NUT $\frac{5}{16}$ -18 HEX FLG NYLOC
14..	539 10 47-63.....	2	RETAINER, U TYPE	29..	539 20 02-82.....	8	NUT $\frac{3}{8}$ -16 HEX JAM NYLOC
15..	539 97 69-89.....	2	HAIRPIN	30..	521 99 65-01.....	7	NUT $\frac{3}{8}$ -16 HEX FLG NYLOC

ENGINE PLATE

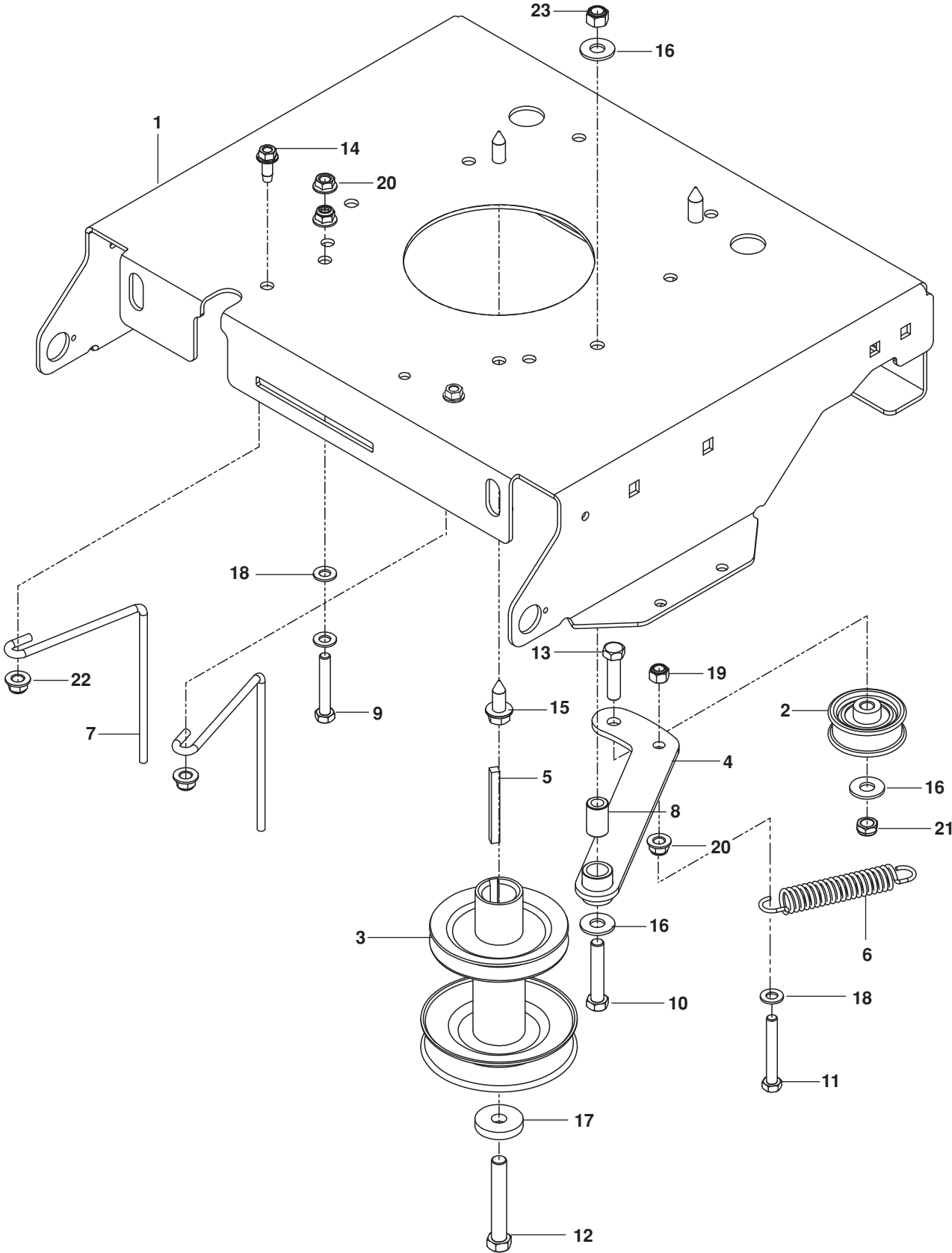

ENGINE PLATE

ITEM	PART NO.	QTY.	DESCRIPTION	ITEM	PART NO.	QTY.	DESCRIPTION
1..	525 46 26-06.....	1	PLATE, ENGINE ORG	13..	874 78 06-24.....	1	BOLT ³ / ₈ -16 x 1½ HEX HD
2..	539 12 08-12.....	1	PULLEY, IDLER	14..	817 49 06-16.....	2	BOLT ³ / ₈ -16 x 1 THD FRM
3..	574 87 28-01.....	1	PULLEY, ENGINE	15..	817 12 06-16.....	3	SCREW ³ / ₈ -16 x 1 THD FRM
4..	539 12 09-90.....	1	IDLER, BLK	16..	819 14 16-14.....	3	WASHER ³ / ₈ FLT STD
5..	539 91 70-33.....	1	KEY ¼ SQ x 2½ LG	17..	539 11 55-46.....	1	WASHER
6..	539 11 63-50.....	1	SPRING 3½	18..	819 11 11-16.....	3	WASHER ⁵ / ₁₆ SAE FLT
7..	574 17 29-01.....	2	GUIDE, BELT	19..	873 80 05-00.....	1	NUT ⁵ / ₁₆ -18 HEX NYLOC
8..	539 11 52-70.....	1	BUSHING, METAL	20..	539 99 05-85.....	2	NUT ⁵ / ₁₆ -18 HEX WHIZLK
9..	539 10 83-95.....	1	BOLT ⁵ / ₁₆ -18 x 2 HEX HD	21..	539 20 02-82.....	1	NUT ³ / ₈ -16 HEX JAM NYLOC
10..	874 78 06-32.....	1	BOLT ³ / ₈ -16 x 2 HEX HD	22..	521 99 65-01.....	2	NUT ³ / ₈ -16 HEX FLG NYLOC
11..	874 78 05-36.....	1	BOLT ⁵ / ₁₆ -18 x 2¼ HEX HD	23..	539 97 69-79.....	1	NUT ³ / ₈ -16 HEX NYLOC
12..	539 11 00-65.....	1	BOLT ⁷ / ₁₆ -20 x 2¾ HEX HD				NOT SHOWN
				----- 1			
				ENGINE, B&S 16.5 HP			
				For engine service and			
				replacement parts, see			
				a Briggs & Stratton dealer			

STEERING

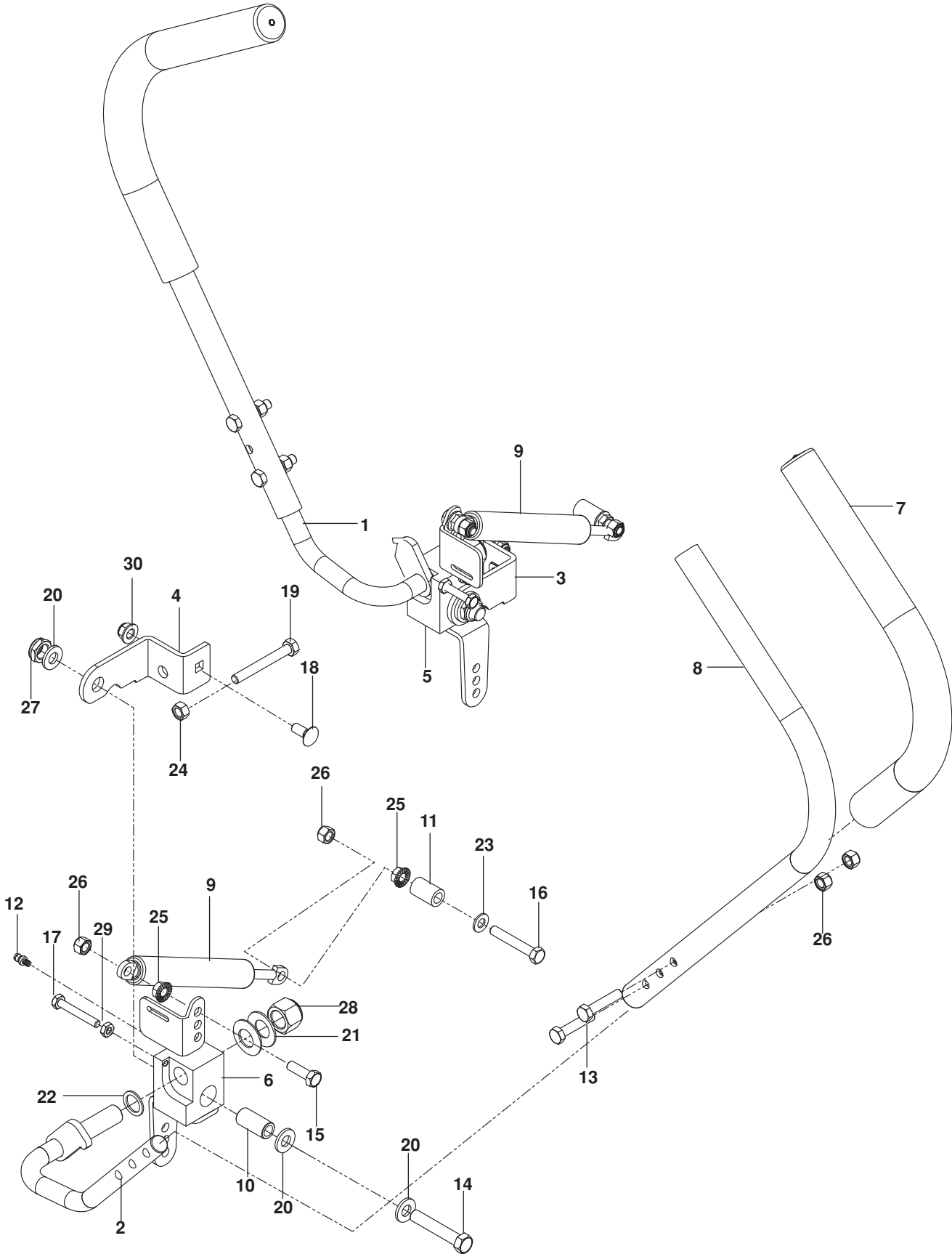

STEERING

ITEM	PART NO.	QTY.	DESCRIPTION	ITEM	PART NO.	QTY.	DESCRIPTION
1..	539 12 01-59.....	1LOWER LEVER, RT	16..	539 10 83-95.....	2BOLT $\frac{5}{16}$ -18 x 2 HEX HD
2..	539 12 01-62.....	1LOWER LEVER, LT	17..	874 78 04-28.....	2BOLT $\frac{1}{4}$ -20 x $1\frac{3}{4}$ HEX HD
3..	539 11 79-49.....	1STOP, STEER CNTRL RT	18..	872 14 05-06.....	2BOLT $\frac{5}{16}$ -18 x $\frac{3}{4}$ RD HD SQNK
4..	539 11 79-50.....	1STOP, STEER CNTRL LT	19..	874 78 05-40.....	2BOLT $\frac{5}{16}$ -18 x $2\frac{1}{2}$ HEX TPBLT
5..	539 12 09-84.....	1PIVOT, RT	20..	819 17 17-13.....	6WASHER $\frac{1}{2}$ SAE
6..	539 12 09-83.....	1PIVOT, LT	21..	539 91 11-21.....	4WASHER $\frac{5}{8}$ BELLEVILLE
7..	539 12 08-99.....	2GRIP	22..	539 11 55-70.....	2WASHER, SPECIAL
8..	539 12 01-60.....	2LEVER, UPPER	23..	819 11 11-16.....	2WASHER $\frac{5}{16}$ SAE FLT
9..	539 11 44-53.....	2DAMPENER	24..	873 22 05-00.....	2NUT $\frac{5}{16}$ -18 HEX
10..	539 12 09-56.....	2BUSHING $\frac{1}{2}$ ID x $\frac{3}{4}$ OD	25..	539 99 05-85.....	2NUT $\frac{5}{16}$ -18 HEX WHIZLK
11..	539 11 90-87.....	2BUSHING	26..	873 80 05-00.....	8NUT $\frac{5}{16}$ -18 HEX NYLOC
12..	539 11 56-38.....	2ZERK	27..	539 10 80-10.....	2NUT $\frac{1}{2}$ -13 JAM NYLOC GR 2
13..	874 78 05-24.....	4BOLT $\frac{5}{16}$ -18 x $1\frac{1}{2}$ HEX HD	28..	539 11 03-40.....	2NUT $\frac{5}{8}$ -11 NYLOC
14..	874 78 08-44.....	2BOLT $\frac{1}{2}$ -13 x $2\frac{3}{4}$ HEX HD	29..	873 35 04-00.....	2NUT $\frac{1}{4}$ -20 JAM
15..	874 78 05-16.....	2BOLT $\frac{5}{16}$ -18 x 1 HEX HD	30..	539 11 28-99.....	2NUT $\frac{5}{16}$ -18 HEX FLG NYLOC

IGNITION SYSTEM

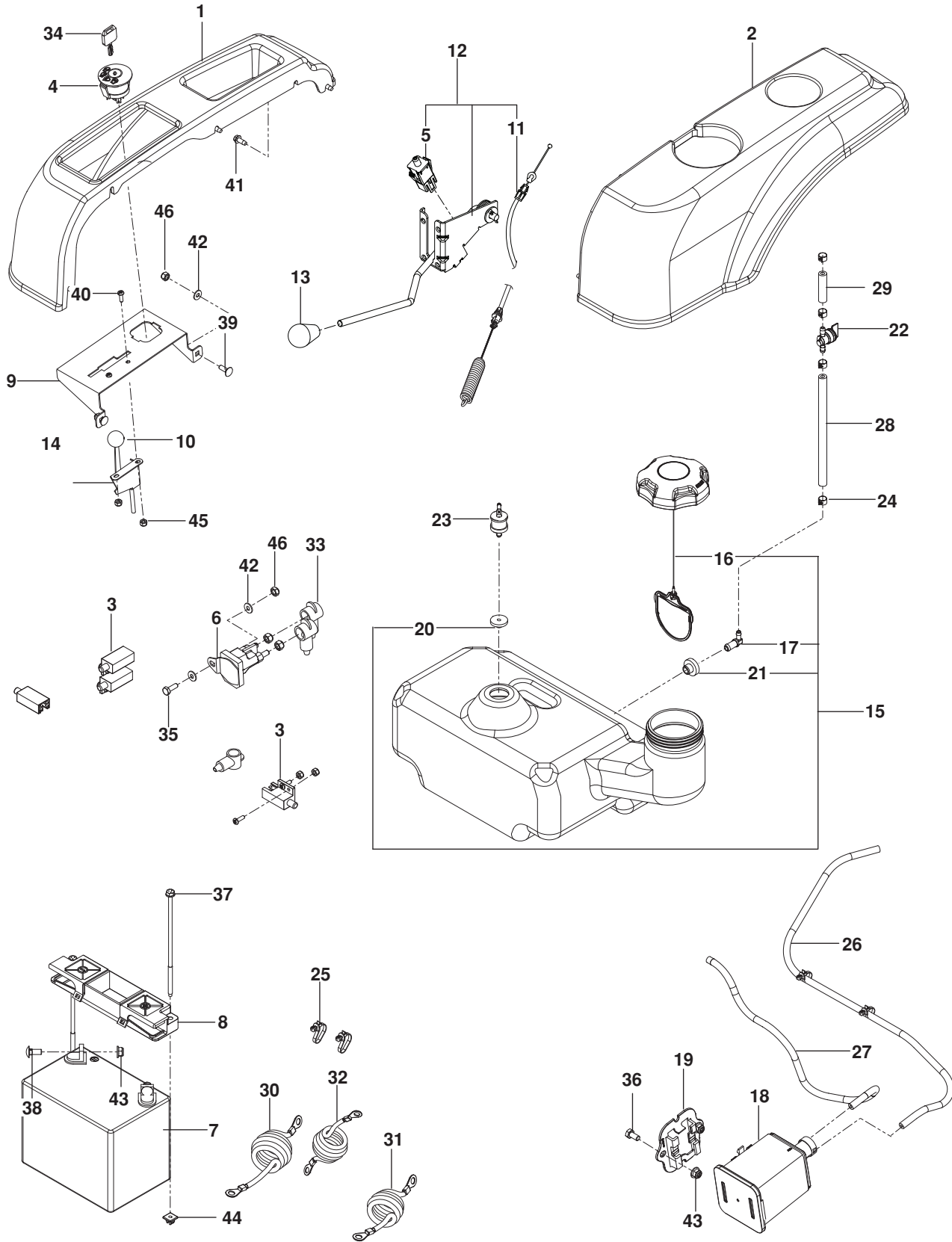

IGNITION SYSTEM

ITEM	PART NO.	QTY.	DESCRIPTION	ITEM	PART NO.	QTY.	DESCRIPTION
1..	525 59 47-01.....	1	FENDER, RT	25..	505 28 00-01.....	4	WIRE TIE w/ CLIP
2..	525 59 47-02.....	1	FENDER, LT	26..	587 04 45-39.....	1	HOSE, FUEL 3/16 x 39"
3..	532 10 95-53.....	4	SWITCH	27..	587 04 45-20.....	1	HOSE, FUEL 3/16 x 20"
4..	539 10 75-41.....	1	SWITCH, IGNITION	28..	587 04 48-08.....	1	HOSE 1/4 x 8
5..	532 17 61-38.....	1	SWITCH, INTERLOCK	29..	587 04 48-02.....	1	HOSE, 1/4 x 2
6..	532 19 25-07.....	1	SOLENOID	30..	539 10 49-74.....	1	CABLE, POSITIVE 31"
7..	539 10 24-36.....	1	BATTERY	31..	539 10 33-06.....	1	CABLE, POSITIVE 19"
8..	539 10 76-28.....	1	HOLD DOWN, BATTERY	32..	539 11 00-68.....	1	CABLE, NEGATIVE 25"
9..	525 59 86-01.....	1	PANEL, CONTROL	33..	532 13 15 63.....	3	COVER, TERMINAL SM
10..	585 97 49-01.....	1	CABLE, THROTTLE	34..	532 14 04-01.....	1	KEY, IGNITION
11..	585 05 38-01.....	1	CABLE, CLUTCH	35..	874 78 04-12.....	2	BOLT 1/4-20 x 3/4 HEX HD
12..	585 05 79-01.....	1	CLUTCH ASSY w/ CABLE	36..	539 10 83-92.....	2	BOLT 5/16-18 x 5/8 HEX HD
13..	539 13 26-24.....	1	KNOB, CLUTCH	37..	532 14 52-11.....	2	BOLT 1/4 x 7 1/2 HEX WSH HD
14..	539 13 30-49.....	1	KNOB	38..	872 14 05-06.....	2	BOLT 5/16-18 x 3/4 RD HD SQNK
15..	576 64 64-03.....	1	TANK ASSY, FUEL	39..	872 11 04-06.....	2	BOLT 1/4-20 x 3/4 RD HD GR 2
16..	575 01 81-01.....	1	CAP, FUEL w/ TETHER	40..	817 49 04-10.....	2	SCREW #10-24 x 5/8
17..	539 11 04-32.....	1	ELBOW	41..	539 97 69-52.....	10	SCREW 1/4-20 x 5/8 SLF TAP
18..	532 41 41-14.....	1	CANISTER, CARBON	42..	819 09 10-16.....	3	WASHER 1/4 FLT SAE
19..	575 24 27-01.....	1	BRACKET, CANISTER	43..	539 11 28-99.....	4	NUT 5/16-18 HEX FLG NYLOC
20..	576 61 82-01.....	1	GROMMET	44..	539 10 76-29.....	2	NUT 1/4 PUSH NYLON
21..	539 10 52-45.....	1	GROMMET	45..	539 97 69-77.....	10	NUT #10-24 HEX NYLOC
22..	539 91 63-25.....	1	VALVE, FUEL	46..	873 80 04-00.....	5	NUT 1/4-20 HEX NYLOC
23..	576 61 81-01.....	1	VALVE, FUEL CHECK	NOT SHOWN			
24..	532 12 34-87.....	4	CLAMP, HOSE	585 50 71-01.....	1	WIRING HARNESS	

HYDRAULIC PUMP / MOTOR

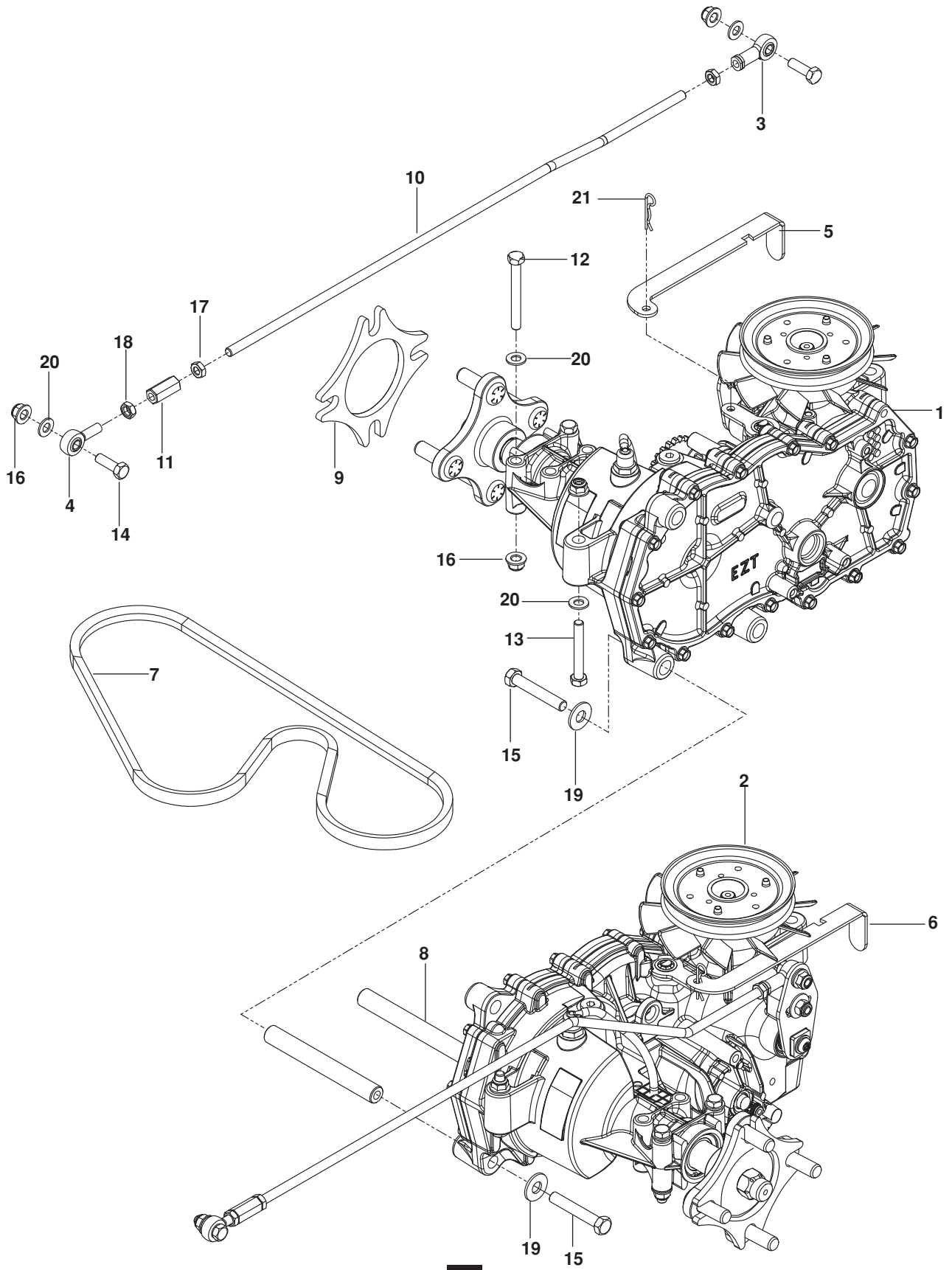

HYDRAULIC PUMP / MOTOR

ITEM	PART NO.	QTY.	DESCRIPTION	ITEM	PART NO.	QTY.	DESCRIPTION
1..	539 12 01-52.....	1HYDRO, RH	12..	874 78 05-44.....	4BOLT ⁵ / ₁₆ -18 x 2 ³ / ₄ HEX HD
2..	539 12 01-53.....	1HYDRO, LH	13..	874 78 05-36.....	2BOLT ⁵ / ₁₆ -18 x 2 ¹ / ₄ HEX HD
3..	539 11 57-29.....	2ROD END, RH	14..	874 78 05-16.....	4BOLT ⁵ / ₁₆ -18 x 1 HEX HD
4..	539 11 66-90.....	2ROD END, MALE LH	15..	874 78 06-36.....	4BOLT ³ / ₈ -16 x 2 ¹ / ₄ HEX HD
5..	539 12 01-57.....	1RELEASE HANDLE, RH	16..	539 11 28-99.....	10NUT ⁵ / ₁₆ -18 HEX FLG NYLOC
6..	539 12 01-56.....	1RELEASE HANDLE, LH	17..	873 36 05-00.....	4NUT ⁵ / ₁₆ -24 HEX JAM
7..	539 12 08-06.....	1BELT, EZT	18..	873 70 05-00.....	2NUT ⁵ / ₁₆ -24 HEX JAM LH
8..	539 12 01-54.....	2SPACER, HYDRO	19..	819 14 16-14.....	4WASHER ³ / ₈ STD FLT
9..	539 11 48-04.....	2SPACER, WHEEL	20..	819 11 11-16.....	10WASHER ⁵ / ₁₆ SAE FLT
10..	539 12 01-69.....	2ROD, CONTROL	21..	539 97 69-88.....	2HAIRPIN COTTER
11..	539 11 66-89.....	2ROD END COUPLER				

WHEELS / TIRES

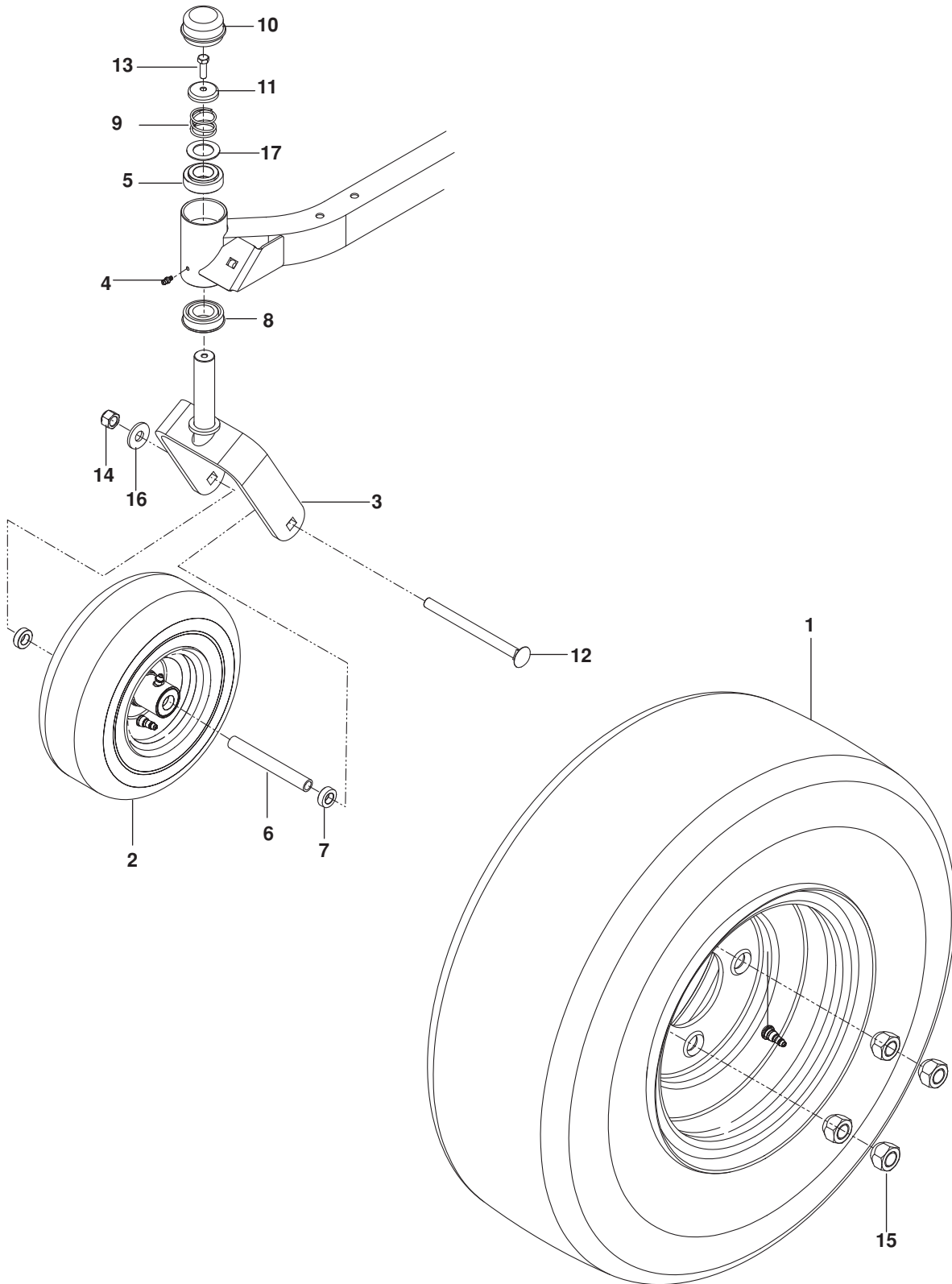

WHEELS / TIRES

ITEM	PART NO.	QTY.	DESCRIPTION	ITEM	PART NO.	QTY.	DESCRIPTION
1..	581 19 90-01.....	2.....	WHEEL ASSY REAR	10..	539 10 25-35.....	2.....	CAP, GREASE
2..	581 19 97-01.....	2.....	CASTER TIRE ASSY	11..	539 11 57-49.....	2.....	PLUG, CASTER
3..	510 18 65-01.....	2.....	YOKE, CASTER ORG	12..	721 40 81-04.....	2.....	BOLT 1/2-13 x 6 1/2 RD HD SQNK
4..	539 11 56-38.....	2.....	ZERK	13..	874 95 05-16.....	2.....	BOLT 5/16-18 x 1 HEX w/ NYLON
5..	539 11 79-01.....	2.....	BUSHING, CASTER	14..	873 93 08-00.....	2.....	NUT 1/2 HEX CNTRLK
6..	584 65 31-01.....	2.....	SPACER	15..	539 10 11-73.....	8.....	NUT 1/2-20 LUG
7..	581 26 92-01.....	4.....	SPACER 5/16	16..	819 18 22-12.....	2.....	WASHER 1/2 FLT
8..	539 11 26-60.....	2.....	BEARING, FLANGED	17..	539 11 56-75.....	2.....	WASHER
9..	539 11 57-47.....	2.....	SPRING, CASTER				

BRAKE / DECK LIFT

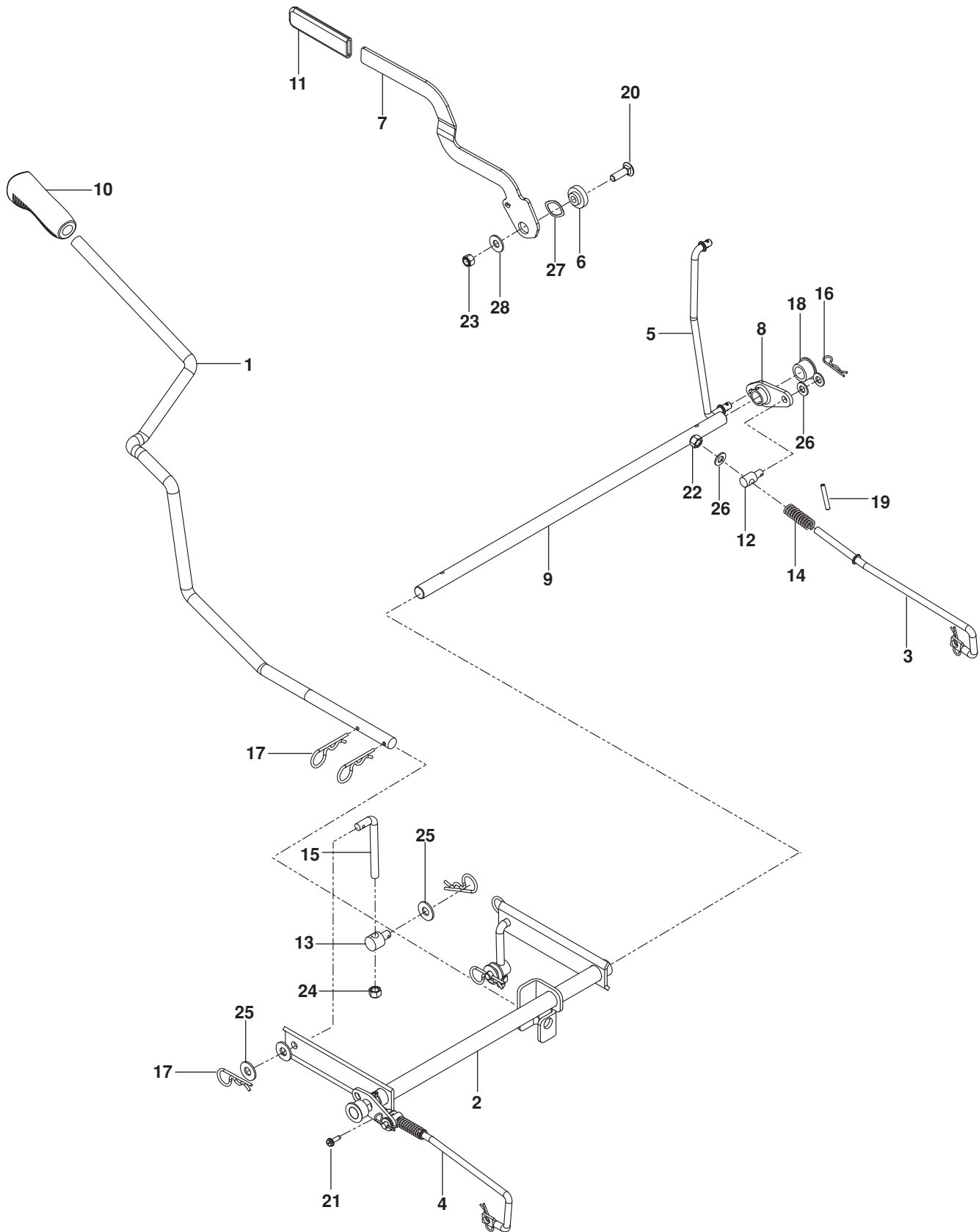

BRAKE / DECK LIFT

ITEM	PART NO.	QTY.	DESCRIPTION	ITEM	PART NO.	QTY.	DESCRIPTION
1..	525 58 04-02.....	1	ARM, LIFT BLK	15..	539 11 56-58.....	2	L-ROD 3½"
2..	525 58 06-04.....	1	SHAFT, LIFT BLK	16..	539 97 69-88.....	4	HAIRPIN COTTER
3..	525 58 36-01.....	1	LINKAGE, BRAKE RT	17..	539 97 69-89.....	6	HAIRPIN
4..	525 58 37-01.....	1	LINKAGE, BRAKE LT	18..	539 10 93-68.....	2	BUSHING, PLASTIC
5..	525 73 57-01.....	1	LINKAGE, UPPER	19..	539 10 10-82.....	2	PIN 3/16 x 1¼ ROLL
6..	539 12 02-20.....	1	PIVOT, BRAKE ARM	20..	872 14 06-10.....	1	BOLT 3/8-16 x 1¼ RD HD SQNK
7..	525 48 56-02.....	1	HANDLE, BRAKE	21..	539 99 10-34.....	2	SCREW #10-24 X 5/8 WSH HD
8..	525 58 02-01.....	2	BELLCRANK, BRAKE	22..	873 80 05-00.....	2	NUT 5/16-18 HEX NYLOC
9..	525 58 03-01.....	1	ROD, BRAKE	23..	539 20 02-82.....	1	NUT 3/8-16 HEX JAM NYLOC
10..	532 44 50-60.....	1	GRIP, LIFT HANDLE	24..	539 97 69-79.....	2	NUT 3/8-16 HEX NYLOC
11..	539 12 09-21.....	1	GRIP, BRAKE HANDLE	25..	819 14 16-14.....	6	WASHER 3/8 FLT STD
12..	539 11 23-08.....	2	SWIVEL, BRAKE	26..	819 11 11-16.....	6	WASHER 5/16 SAE FLT
13..	539 11 81-79.....	2	SWIVEL	27..	539 13 30-07.....	1	WASHER, .825 WAVE
14..	539 10 12-24.....	2	SPRING	28..	539 10 28-43.....	1	WASHER 7/16 SPRING DISK

MOWER DECK / CUTTING DECK

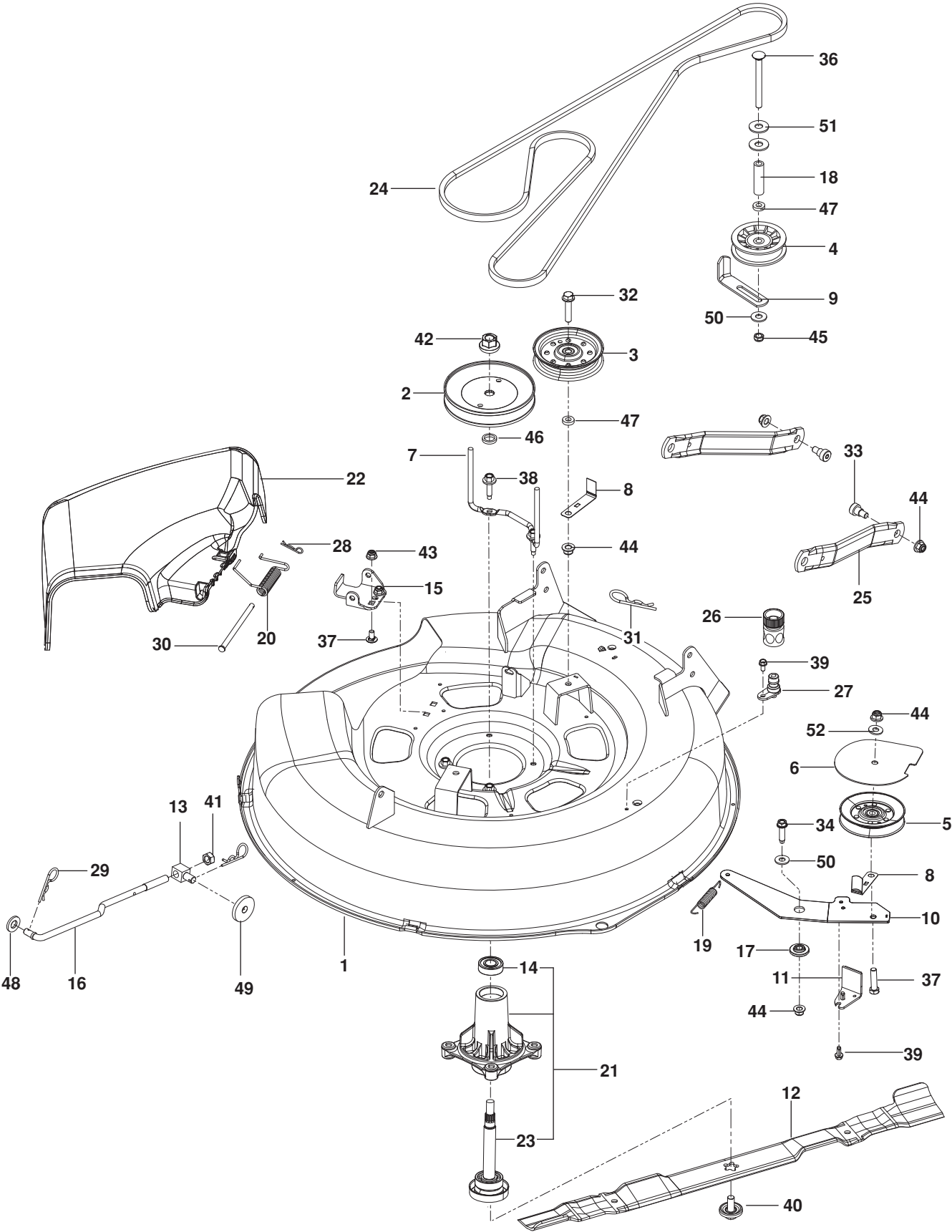

MOWER DECK / CUTTING DECK

ITEM	PART NO.	QTY.	DESCRIPTION	ITEM	PART NO.	QTY.	DESCRIPTION
1..	574 45 34-01.....	1	DECK w/ SAFETY DECALS	27..	532 41 55-98.....	1	PORT, WASHOUT
2..	532 19 97-91.....	1	PULLEY, MANDREL	28..	539 97 69-88.....	1	HAIRPIN COTTER
3..	532 17 58-20.....	1	PULLEY, IDLER	29..	539 97 69-89.....	2	HAIRPIN
4..	539 11 03-11.....	1	PULLEY, DECK IDLER	30..	539 11 07-36.....	1	PIN, CLEVIS ⁵ / ₁₆
5..	532 17 39-02.....	1	IDLER, V-GROOVE	31..	532 16 58-98.....	1	RETAINER
6..	573 97 04-02.....	1	COVER, PULLEY	32..	539 99 07-01.....	1	BOLT ³ / ₈ -16 x 1 ³ / ₄ WHIZLK
7..	532 40 01-40.....	1	KEEPER, BELT	33..	539 11 36-21.....	2	BOLT ³ / ₈ -16 x ³ / ₈ SKT HD
8..	532 42 02 53.....	2	KEEPER, BELT	34..	817 49 06-24.....	1	BOLT ³ / ₈ -16 x 1 ¹ / ₂ THD FRM
9..	525 85 18-01.....	1	GUIDE, BELT	35..	874 78 06-32.....	1	BOLT ³ / ₈ -16 x 2 HEX HD
10..	585 05 39-02.....	1	ARM, IDLER BLK	36..	525 84 86-01.....	1	BOLT ³ / ₈ -16 x 4 RD HD SQNK
11..	532 40 01-30.....	1	ARM, LT BRAKE	37..	872 11 05-05.....	2	BOLT ⁵ / ₁₆ -18 x ⁵ / ₈ RD HD SQNK
12..	532 41 92-74.....	1	BLADE, MOWER/MULCH	38..	584 95 39-01.....	4	SCREW ⁵ / ₁₆ -18 WASHER HD
13..	581 51 43-01.....	1	SWIVEL	39..	817 49 04-08.....	3	SCREW ¹ / ₄ -20 x ¹ / ₂ THDROLL
14..	532 11 04-85.....	1	BEARING, BALL	40..	532 19 30-03.....	1	BOLT/WASHER
15..	532 19 25-57.....	1	BRACKET, DEFLECTOR	41..	573 97 52-01.....	1	NUT ⁷ / ₁₆ -20 HEX NYLOC
16..	532 19 57-40.....	1	LINK, SUSPENSION	42..	532 40 02-34.....	1	NUT ⁹ / ₁₆ TOP CNTRLK
17..	532 19 90-92.....	1	SPACER RETAINER	43..	539 11 28-99.....	2	NUT ⁵ / ₁₆ -18 HEX FLG NYLOC
18..	525 84 88-01.....	1	SPACER 2 ¹ / ₄	44..	521 99 65-01.....	5	NUT ³ / ₈ -16 HEX FLG NYLOC
19..	532 19 32-16.....	1	SPRING, RETURN	45..	873 35 06-00.....	1	NUT ³ / ₈ -16 HEX JAM
20..	532 17 81-02.....	1	SPRING, TORSION	46..	532 18 76-90.....	1	WASHER/SPACER
21..	532 19 28-70.....	1	MANDREL	47..	539 10 95-62.....	1	WASHER ³ / ₈ x ³ / ₄
22..	532 41 73-44.....	1	DEFLECTOR	48..	819 17 17-13.....	1	WASHER ¹ / ₂ SAE
23..	532 19 28-72.....	1	SHAFT	49..	539 10 65-04.....	1	WASHER 1 ³ / ₄ x ¹ / ₄ HEAVY
24..	585 05 40-01.....	1	BELT, DECK	50..	819 14 16-14.....	2	WASHER ³ / ₈ FLT STD
25..	532 19 51-85.....	2	ARM, DECK SUSPENSION	51..	539 10 48-64.....	2	WASHER ⁷ / ₁₆ FLT
26..	532 41 64-05.....	1	COUPLING, QUICK DISC	52..	819 13 13-16.....	1	WASHER ³ / ₈ SAE FLT

SEAT

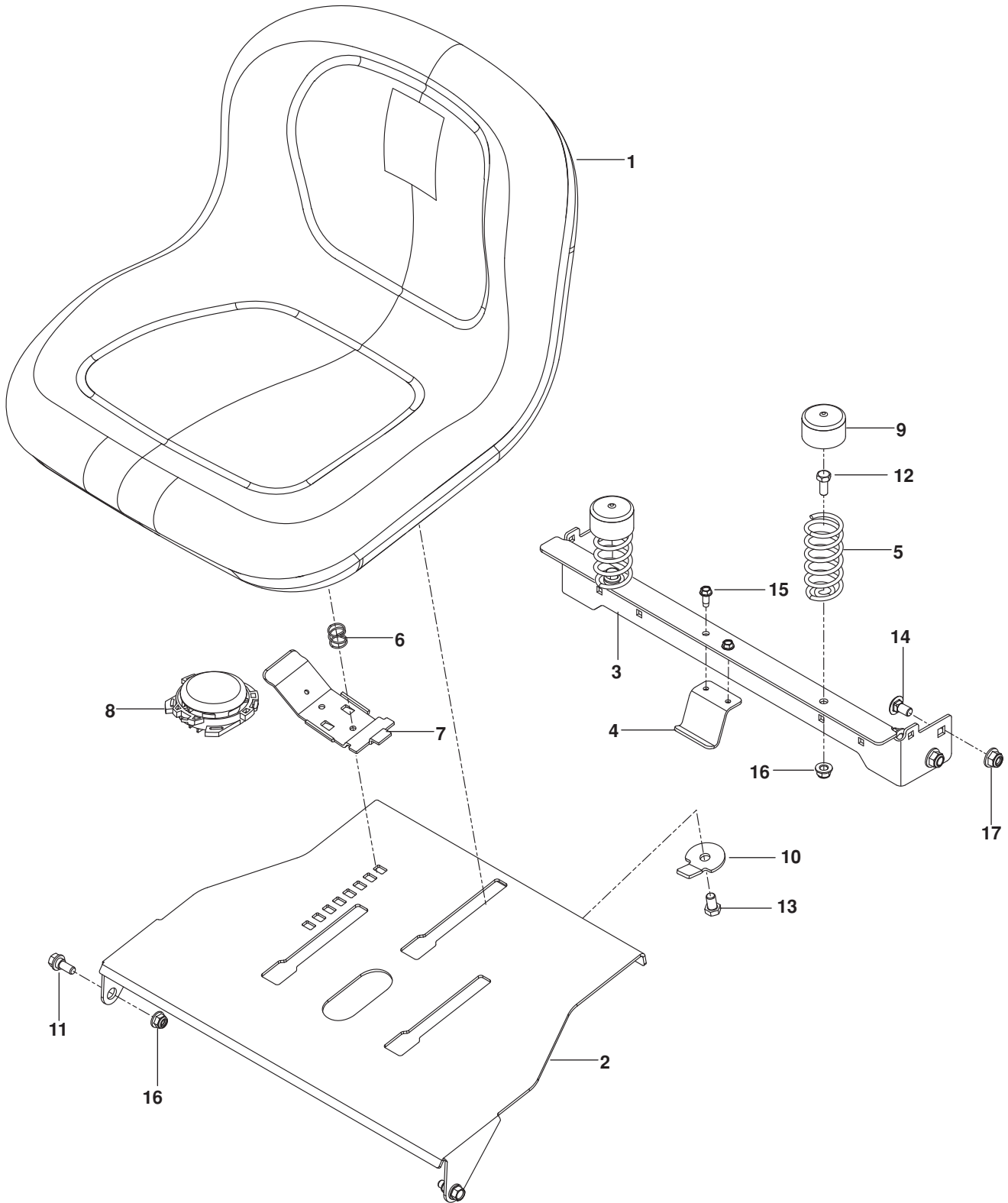

SEAT

ITEM	PART NO.	QTY.	DESCRIPTION
1..	532 43 98-22.....	1	SEAT
2..	525 58 00-02.....	1	PLATE, SEAT ORG
3..	525 46 46-02.....	1	SUPPORT, REAR SEAT ORG
4..	525 86 45-02.....	1	BRACKET, FUEL TANK BLK
5..	539 12 26-32.....	2	SPRING, SEAT
6..	532 19 82-00.....	1	SPRING, SEAT SLIDE
7..	532 19 76-61.....	1	HANDLE, SEAT SLIDE
8..	539 11 98-84.....	2	CAP, SPRING
9..	539 13 21-40.....	1	SWITCH, SEAT N/C

ITEM	PART NO.	QTY.	DESCRIPTION
10..	574 19 10-02.....	1	STOP, SEAT BLK
11..	539 11 03-03.....	2	BOLT ⁵ / ₁₆ -SHOULDER
12..	539 99 03-69.....	2	BOLT ⁵ / ₁₆ -18 x 1 HEX HD
13..	874 78 06-10.....	1	BOLT ³ / ₈ -16 x ⁵ / ₈ HEX HD
14..	872 14 06-06.....	4	BOLT ³ / ₈ -16 x ³ / ₄ RD HD SQNK
15..	817 49 04-10.....	2	SCREW ¹ / ₄ -20 x ⁵ / ₈ SLF TAP
16..	539 11 28-99.....	4	NUT ⁵ / ₁₆ -18 HEX FLG NYLOC
17..	521 99 65-01.....	3	NUT ³ / ₈ -16 HEX FLG NYLOC

DECALS

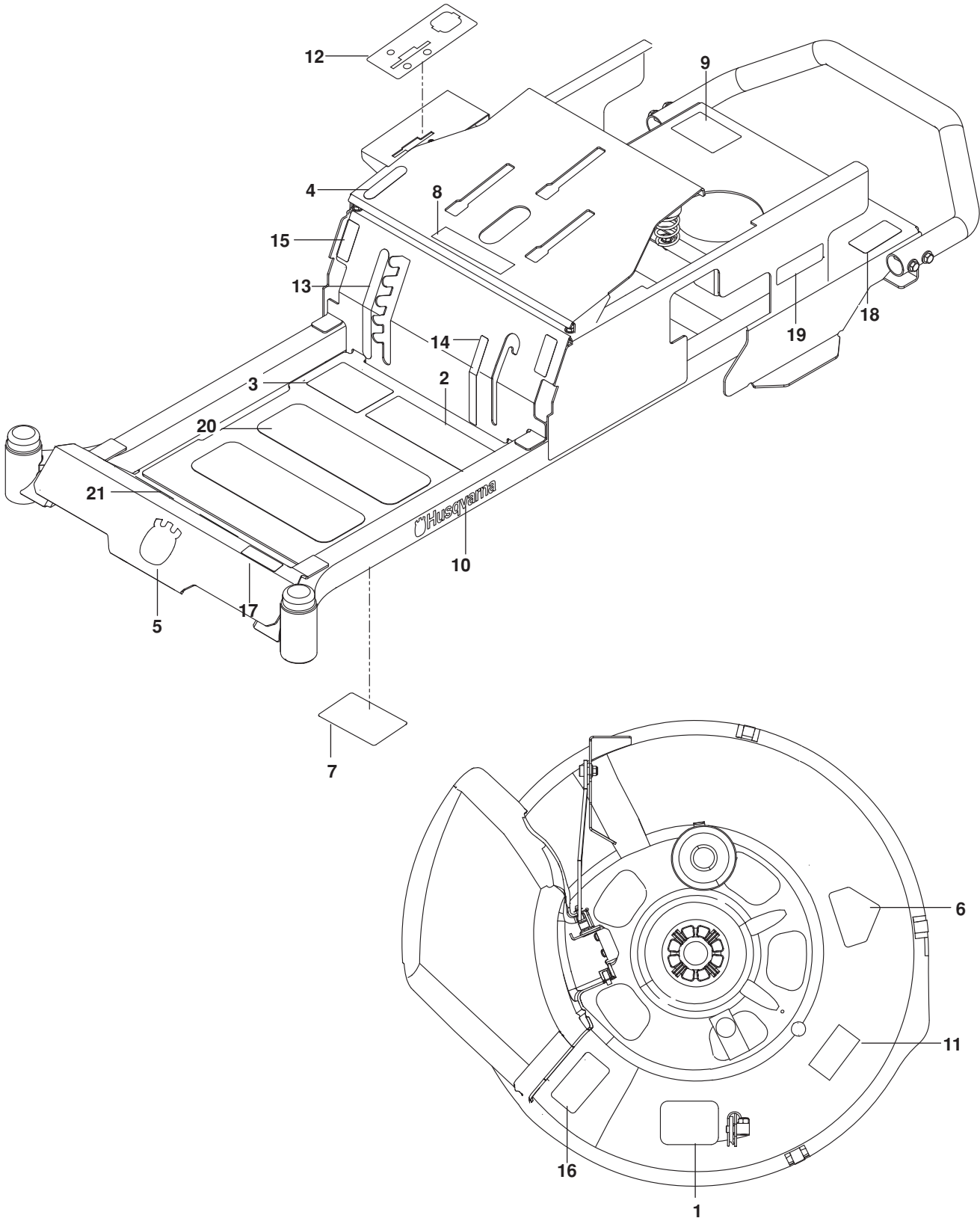

DECALS

ITEM	PART NO.	QTY.	DESCRIPTION	ITEM	PART NO.	QTY.	DESCRIPTION
1..	525 79 85-01.....	1	DECAL, BELT ROUTING	12..	585 98 49-01.....	1	DECAL, CONTROL PANEL
2..	539 10 99-08.....	1	DECAL, SAFETY WARNING	13..	525 81 42-01.....	1	DECAL, DECK HEIGHT
3..	586 25 84-01.....	1	DECAL, START	14..	525 81 43-01.....	1	DECAL, BLADE ENGAGE
4..	539 12 00-06.....	1	DECAL, PARK BRAKE	15..	539 10 33-33.....	2	DECAL, MOTION CONTROL
5..	532 42 86-76.....	1	DECAL, CROWN	16..	581 72 44-01.....	1	DECAL, DEFLECT CAUTION
6..	584 90 46-01.....	1	DECAL, BLADE WARN	17..	525 80 33-01.....	1	DECAL, RZ3016
7..	539 10 98-97.....	1	DECAL, SERVICE	18..	539 10 18-81.....	1	DECAL, PROP 65
8..	539 10 57-45.....	1	DECAL, BATTERY WARNING	19..	532 42 41-02.....	1	DECAL, SPARK ARRESTOR
9..	539 10 83-85.....	1	DECAL, DO NOT TOW	20..	539 97 77-78.....	2	PAD, ABRASIVE
10..	532 42 91-96.....	2	DECAL, HUSQVARNA	21..	539 12 13-22.....	2	PAD, FOOT
11..	539 10 57-46.....	1	DECAL, SEVERING				

ACCESSORIES

BAGGER

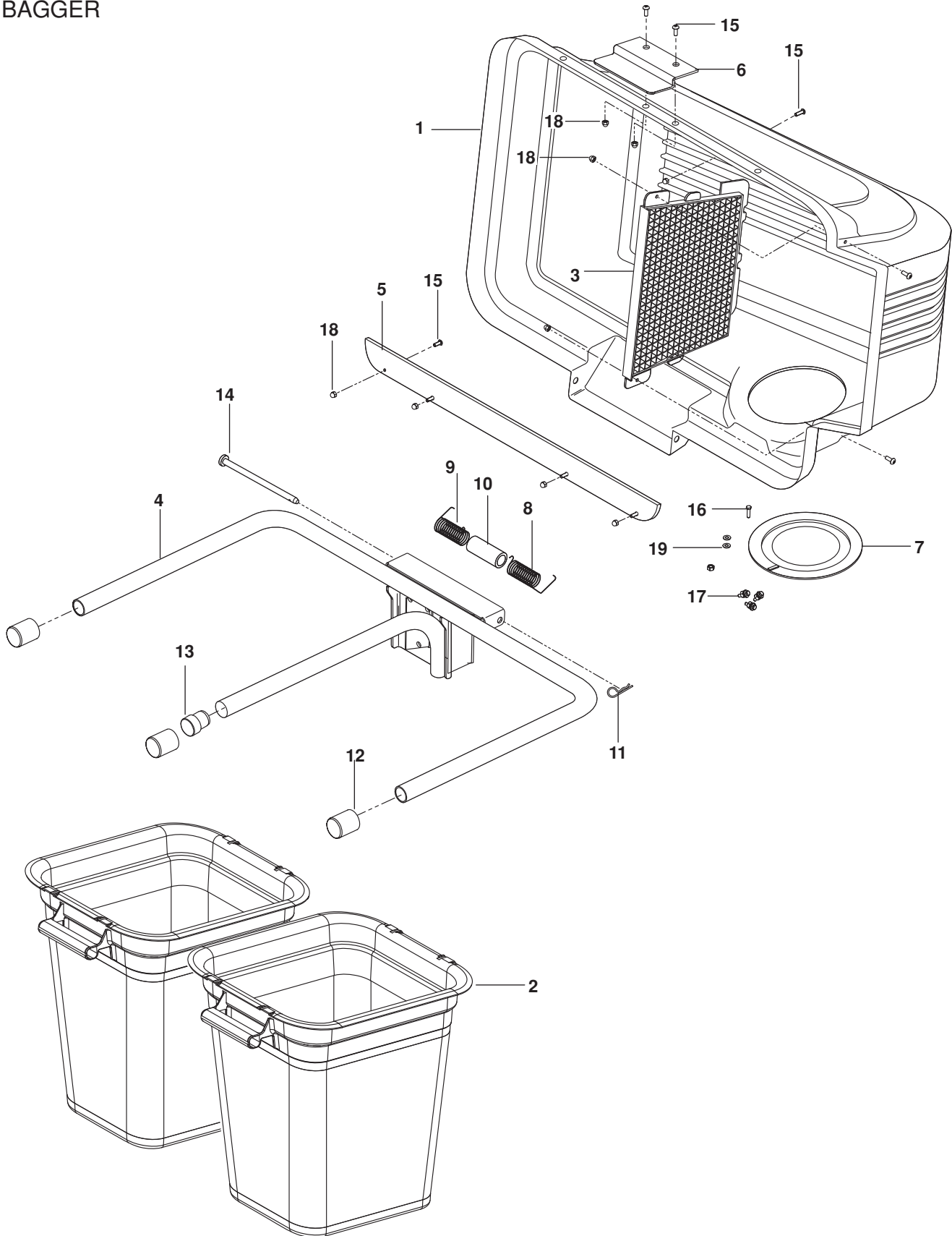

ACCESSORIES

ITEM	PART NO.	QTY.	DESCRIPTION	ITEM	PART NO.	QTY.	DESCRIPTION
1..	539 11 11-39.....	1	COVER ASSY, COMPLETE	11..	539 10 80-96.....	1	HAIRPIN, RETAINER
2..	532 40 02-26.....	2	CONTAINER, SOFT BAG	12..	539 10 80-97.....	3	CAP, TUBING END
3..	532 12 75-33.....	1	SCREEN, COVER	13..	522 80 13-01.....	1	SPACER PLUG
4..	532 17 97-46.....	1	BAGGER, FRAME	14..	532 19 27-86.....	1	PIN, HINGE
5..	532 15 50-42.....	1	STRIP, REINFORCEMENT	15..	539 97 69-52.....	9	SCREW #10-24 x 5/8
6..	532 13 08-95.....	1	LATCH HANDLE, COVER	16..	539 10 63-12.....	4	SCREW #10-24 x 3/4
7..	532 12 75-34.....	1	GASKET	17..	539 97 69-77.....	4	NUT #10-24 HEX NYLOC
8..	532 13 27-96.....	1	SPRING, COVER LH	18..	539 10 80-86.....	9	NUT #10-24 ACORN
9..	532 13 29-83.....	1	SPRING, COVER RH	19..	539 10 54-08.....	8	WASHER #10 FLT
10..	532 13 32-35.....	1	SPACER, COVER				

ACCESSORIES

MOUNTS, CHUTES, WEIGHTS

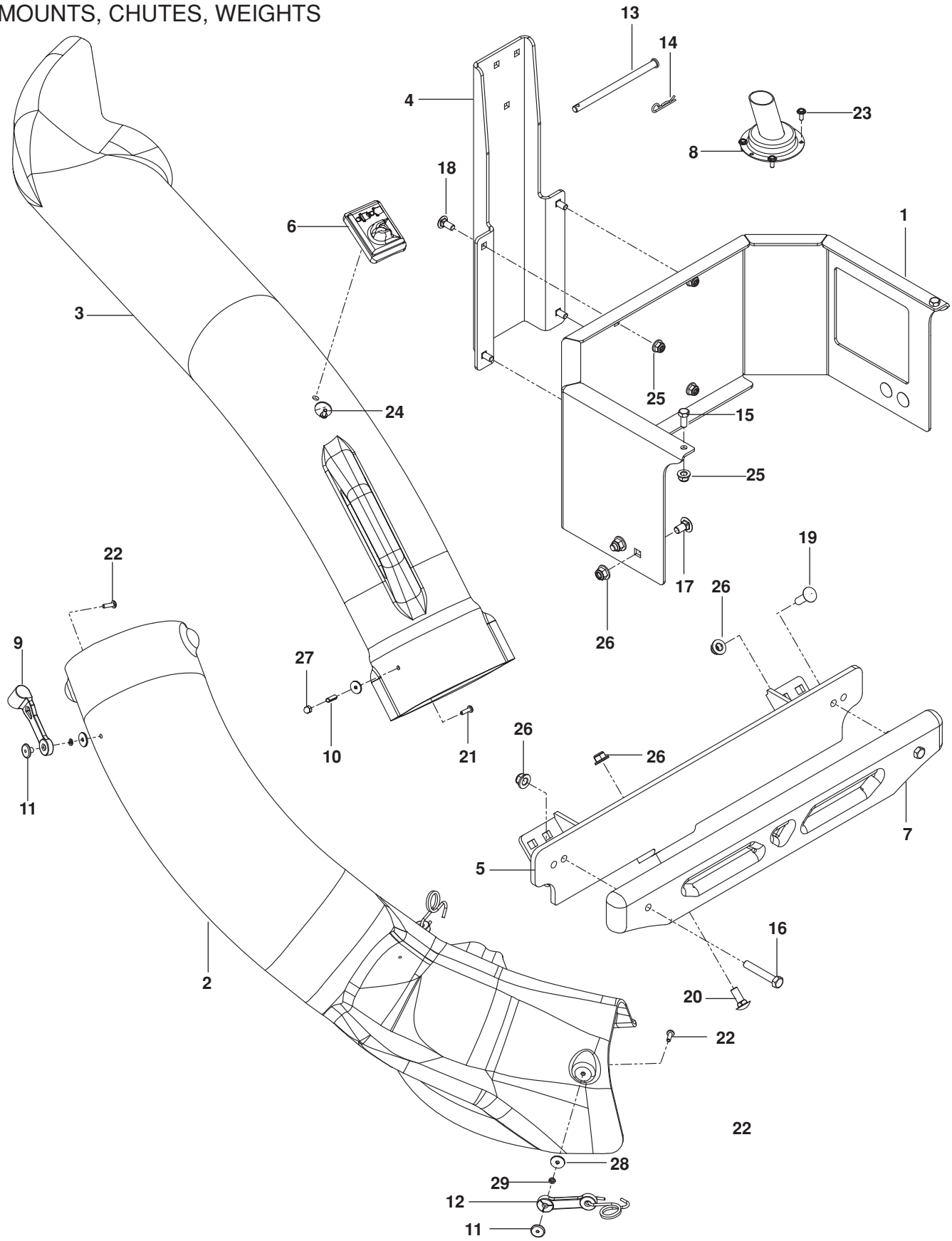

ACCESSORIES

ITEM	PART NO.	QTY.	DESCRIPTION
1..	574 03 10-03.....	1	GUARD, REAR
2..	573 97 58-01.....	1	CHUTE, LOWER
3..	539 10 81-41.....	1	CHUTE, UPPER
4..	574 03 11-02.....	1	BRACKET, HANGER
5..	574 25 55-02.....	1	BRACKET, WEIGHT
6..	539 10 80-82.....	1	BAG INDICATOR
7..	539 11 31-77.....	1	CAST WEIGHT
8..	539 13 16-01.....	1	EXTENSION, MUFFLER
9..	539 10 80-88.....	1	LATCH, HOOD
10..	539 10 80-85.....	1	SPACER, SPLIT
11..	539 10 80-89.....	3	WELDNUT, PLATED
12..	539 10 81-94.....	2	LATCH ASSY
13..	539 11 07-36.....	1	PIN, CLEVIS $\frac{5}{16}$ x 5.19
14..	539 97 69-88.....	1	COTTER HAIRPIN
15..	539 97 69-34.....	2	BOLT $\frac{5}{16}$ -18 x $\frac{3}{4}$ HEX HD

ITEM	PART NO.	QTY.	DESCRIPTION
16..	539 99 06-29.....	2	BOLT $\frac{3}{8}$ -16 x 2 $\frac{1}{4}$ HEX HD
17..	539 11 17-85.....	4	BOLT $\frac{3}{8}$ -16 x $\frac{3}{4}$ RD HD SQNK
18..	539 99 03-16.....	4	BOLT $\frac{5}{16}$ -18 x $\frac{3}{4}$ RD HD SQNK
19..	539 99 06-45.....	1	BOLT $\frac{3}{8}$ -16 x 1 RD HD SQNK
20..	539 10 04-13.....	2	BOLT $\frac{3}{8}$ -16 x 1 $\frac{1}{4}$ RD HD SQNK
21..	539 10 80-83.....	1	SCREW #10- 24 x 1 $\frac{1}{8}$
22..	539 97 69-52.....	3	SCREW #10-24 x .625
23..	539 11 55-37.....	4	SCREW, HEX WASHER HD
24..	539 10 80-81.....	1	SCREW, SPECIAL #10-14 x $\frac{1}{2}$
25..	539 11 28-99.....	6	NUT $\frac{5}{16}$ -18 HEX FLG NYLOC
26..	521 99 65-01.....	9	NUT $\frac{3}{8}$ -16 HEX FLG
27..	539 10 80-86.....	1	NUT #10- 24 ACORN
28..	539 10 80-84.....	3	WASHER $\frac{3}{16}$ x $\frac{3}{4}$ x 16 GA
29..	539 10 95-52.....	3	WASHER $\frac{3}{16}$ LOCK

ACCESSORIES

MULCH KIT

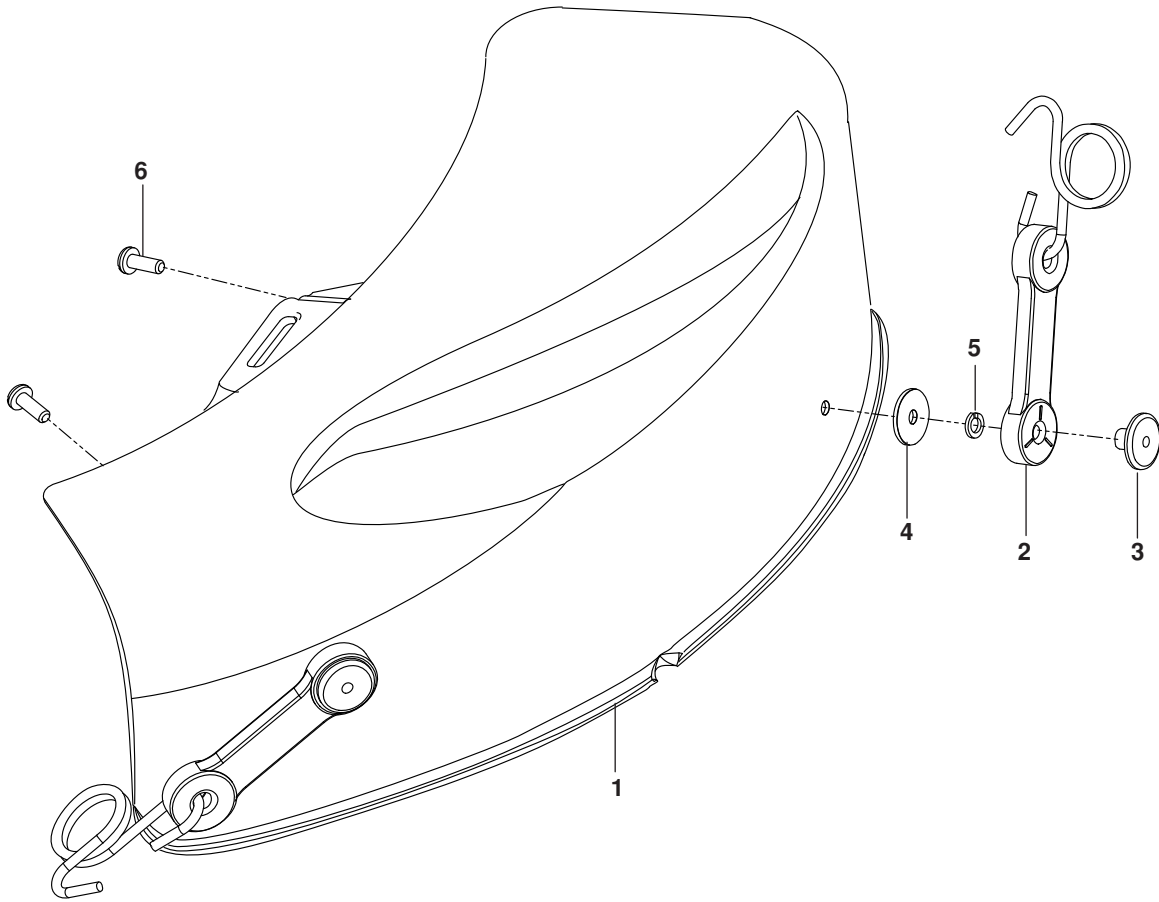

ACCESSORIES

ITEM	PART NO.	QTY.	DESCRIPTION
1..	532 42 17-17.....	1.....	COVER
2..	532 16 07-93.....	2.....	LATCH ASSY
3..	539 10 80-89.....	2.....	WELDNUT, PLATED

ITEM	PART NO.	QTY.	DESCRIPTION
4..	819 03 12-16.....	2.....	WASHER
5..	810 07 10-00.....	2.....	WASHER LOCK
6..	871 08 10-10.....	2.....	SCREW

www.husqvarna.com

115 71 74-27 Rev A
2014-08-01