

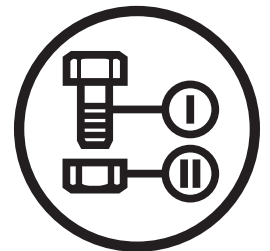

Parts Manual

Z 246i

Zero Turn Mower / 967323901-00



Please read the operator manual carefully and make sure you understand the instructions before using the machine.

When you need spare parts or support in service questions, warranty issues, etc., please consult the following professional:

This manual belongs to the machine with the manufacturing number:	Engine	Transmission

Manufacturing Number

The machine's manufacturing number can be found on the printed plate affixed to the engine compartment.

Stated on the plate, from the top are:

- The machine's type designation (I.D.).
- The manufacturer's type number (Model).
- The machine's serial number (Serial no.)

Please have the type designation and serial number available when ordering spare parts.

The engine's manufacturing number is stamped on one of the valve covers.

The plate states:

- The engine's model.
- The engine's type.
- Code

Please have these available when ordering spare parts.

The wheel motors and hydrostatic pumps have a barcode decal affixed at the rear.

Accessories Available	
Collection System.....	966 004101
Mulch Kit.....	531 309580

CONTENTS

FRAME.....	4
ENGINE PLATE.....	6
STEERING	8
IGNITION.....	10
BRAKE / LIFT.....	12
HYDRAULIC PUMP - MOTOR.....	14
WHEELS AND TIRES.....	16
MOWER DECK / CUTTING DECK.....	18
SEAT	20
DECALS.....	22
ACCESSORIES	
BAGGER.....	24
CHUTES, MOUNT.....	26

Illustrations may or may not represent the actual assemblies and it is not recommended to use this manual as a guide to assemble or disassemble the mower.

NOTE: All fasteners are Grade 5 unless otherwise specified.

FRAME

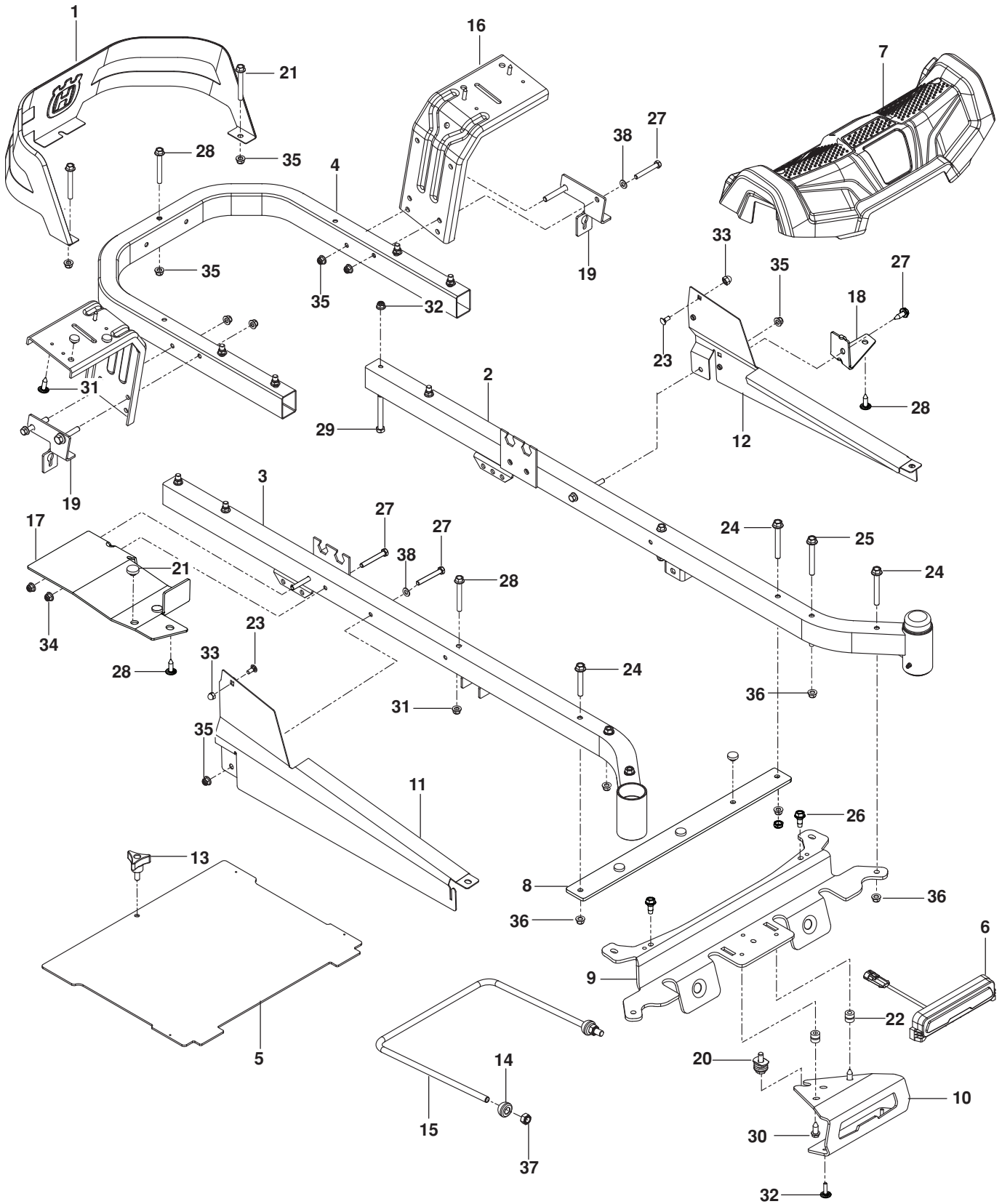

FRAME

ITEM	PART NO.	QTY.	DESCRIPTION	ITEM	PART NO.	QTY.	DESCRIPTION
1..	585 03 98-02.....	1	GUARD, REAR BLK	20..	587 54 69-01.....	1	ASSY, ISOLATOR TAP
2..	510 17 75-03.....	1	FRAME, FRONT RT ORG	21..	585 98 93-01.....	7	GROMMET, BUMPER
3..	510 17 74-03.....	1	FRAME, FRONT LT ORG	22..	587 22 52-01.....	2	GROMMET, PUSH
4..	584 99 10-02.....	1	FRAME, REAR TUBE ORG	23..	585 94 00-01.....	2	BOLT ⁵ / ₁₆ -18 x 1 CARRIAGE
5..	522 84 29-02.....	1	FOOT PLATE w/ SAFETY DECAL	24..	577 11 77-01.....	4	BOLT ³ / ₈ -16 x 3
6..	585 91 67-01.....	1	ASSY, LED LIGHT	25..	586 65 43-01.....	2	BOLT ³ / ₈ -16 x 3 SHOULDER
7..	585 52 24-01.....	1	COVER, FOOTREST	26..	586 88 11-01.....	2	BOLT ⁵ / ₁₆ -18 SHOULDER
8..	585 52 30-04.....	1	SUPPORT, FOOTREST	27..	874 78 05-36.....	8	BOLT ⁵ / ₁₆ -18 x 2 ¹ / ₄
9..	585 52 31-04.....	1	CROSS MEMBER	28..	874 78 05-44.....	5	BOLT ⁵ / ₁₆ -18 x 2 ³ / ₄
10..	587 45 86-02.....	1	BRACKET, SKID	29..	874 78 06-48.....	8	BOLT ³ / ₈ -16 x 3
11..	585 33 16-02.....	1	COVER, RAIL RT	30..	817 58 52-00.....	2	SCREW ⁵ / ₁₆ -18 x 1 ¹ / ₄ WSH HD
12..	585 33 15-02.....	1	COVER, RAIL LT	31..	532 41 63-58.....	6	SCREW #10-24 x ³ / ₄ HEX HD
13..	539 10 44-11.....	1	KNOB w/ STUD	32..	532 42 17-56.....	2	SCREW #10 x ¹ / ₂
14..	532 19 52-63.....	2	BUSHING, PIVOT	33..	585 93 81-01.....	2	NUT ⁵ / ₁₆ -18 ACORN
15..	521 93 81-01.....	1	LINK, FRONT SUSPENSION	34..	873 90 05-00.....	2	NUT ⁵ / ₁₆ -18 HEX FLG LCK
16..	580 50 13-02.....	2	SUPPORT, FENDER BLK	35..	539 11 28-99.....	9	NUT ⁵ / ₁₆ -18 HEX FLG NYLOC
17..	585 52 34-04.....	1	SUPPORT, CONSOLE RT	36..	521 99 65-01.....	8	NUT ³ / ₈ -16 HEX FLG NYLOC
18..	585 52 36-04.....	1	SUPPORT, CONSOLE LT	37..	539 11 91-24.....	2	NUT ⁷ / ₁₆ -14 HEX NYLOC
19..	585 47 43-02.....	2	BRACKET, BYPASS ROD	38..	819 11 11-16.....	6	WASHER ⁵ / ₁₆ SAE FLT

ENGINE PLATE

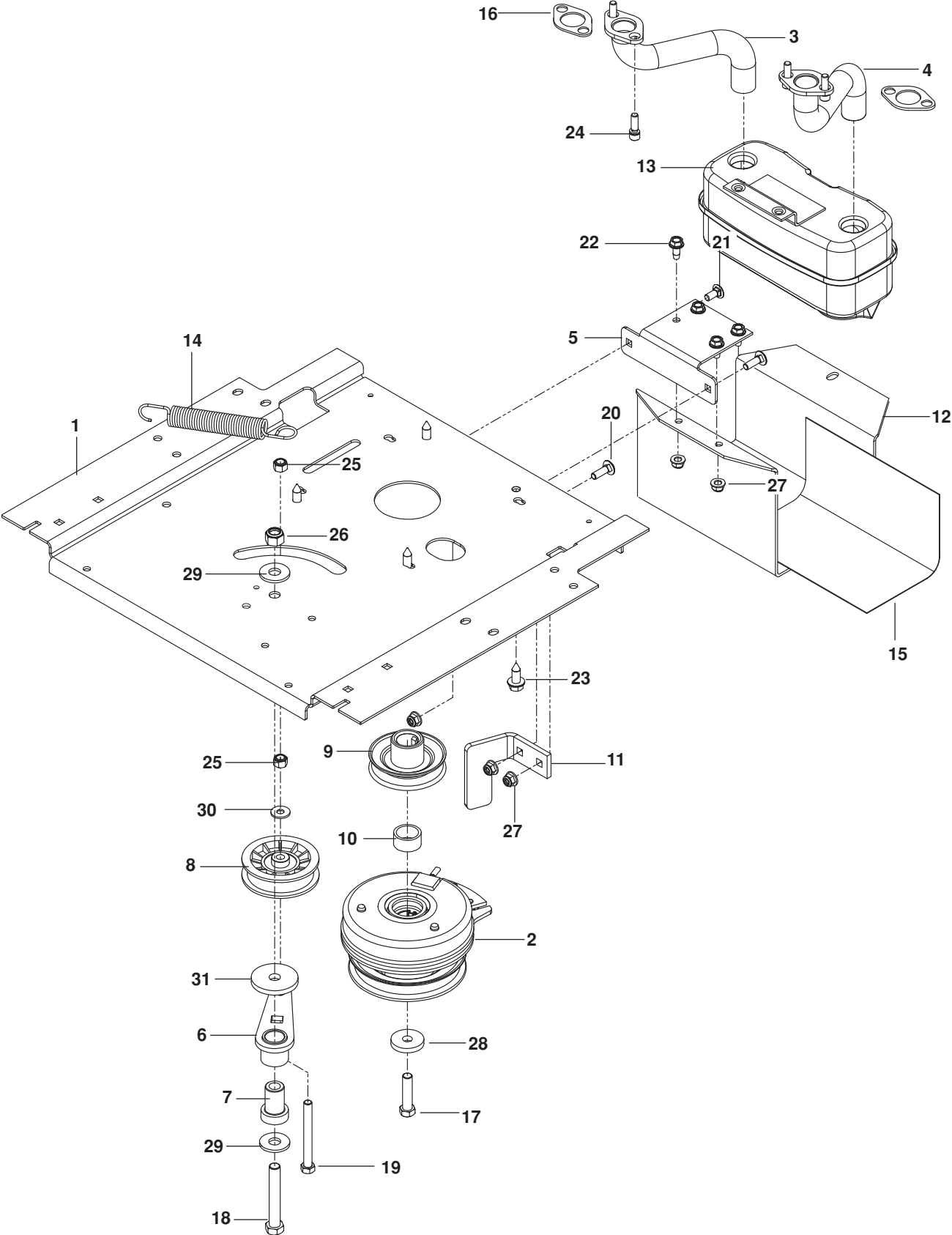

ENGINE PLATE

ITEM	PART NO.	QTY.	DESCRIPTION
1..	587 48 07-02.....	1	PLATE, ENGINE BLK
2..	585 52 11-01.....	1	CLUTCH
3..	581 88 10-01.....	1	TUBE, EXHAUST RT
4..	581 88 11-01.....	1	TUBE, EXHAUST LT
5..	581 88 67-02.....	1	BRACKET, MUFFLER BLK
6..	532 44 81-45.....	1	ARM, IDLER
7..	539 10 12-31.....	1	SPINDLE, IDLER
8..	539 11 03-11.....	1	PULLEY, IDLER
9..	539 11 45-30.....	1	PULLEY, ENGINE
10..	539 11 22-52.....	1	SPACER
11..	510 24 60-02.....	1	STOP, CLUTCH BLK
12..	587 45 12-02.....	1	GUARD, MUFFLER BLK
13..	539 13 16-04.....	1	MUFFLER ASSY
14..	532 19 61-05.....	1	SPRING, DECK DRIVE
15..	539 13 28-59.....	1	SHIELD, MUFFLER
16..	532 16 53-91.....	2	GASKET, MUFFLER
17..	581 33 28-04.....	1	BOLT $7/16$ -20 x $1\frac{1}{2}$
18..	874 78 08-52.....	1	BOLT $1/2$ -13 x $3/4$

ITEM	PART NO.	QTY.	DESCRIPTION
19..	874 52 06-56.....	1	BOLT $3/8$ -16 x $3\frac{1}{2}$
20..	872 14 05-08.....	2	BOLT RD HD SQNK $5/16$ -18 x 1
21..	872 14 05-06.....	2	BOLT RD HD SQNK $5/16$ -18 x $3/4$
22..	817 49 05-12.....	4	SCREW $5/16$ -18 x $3/4$ THD FRM
23..	817 12 06-16.....	4	SCREW $3/8$ -16 x 1 THD FRM
24..	532 18 39-06.....	4	SCREW $5/16$ -18 x 1 SKT HD
25..	539 97 69-79.....	2	NUT $3/8$ -16 HEX NYLOC
26..	873 80 08-00.....	1	NUT $1/2$ -13 HEX NYLOC
27..	539 11 28-99.....	5	NUT $5/16$ -18 HEX FLG NYLOC
28..	532 12 61-97.....	1	WASHER, CLUTCH
29..	819 18 22-12.....	2	WASHER $1/2$ FLT
30..	819 12 14-14.....	2	WASHER $5/16$ STD FLT
31..	539 11 26-70.....	1	WASHER, HEAVY
NOT SHOWN			
	-----	1	ENGINE, BRIGGS & STRATTON 44S777 23 HP For engine service and replacement parts, see a B&S dealer

STEERING

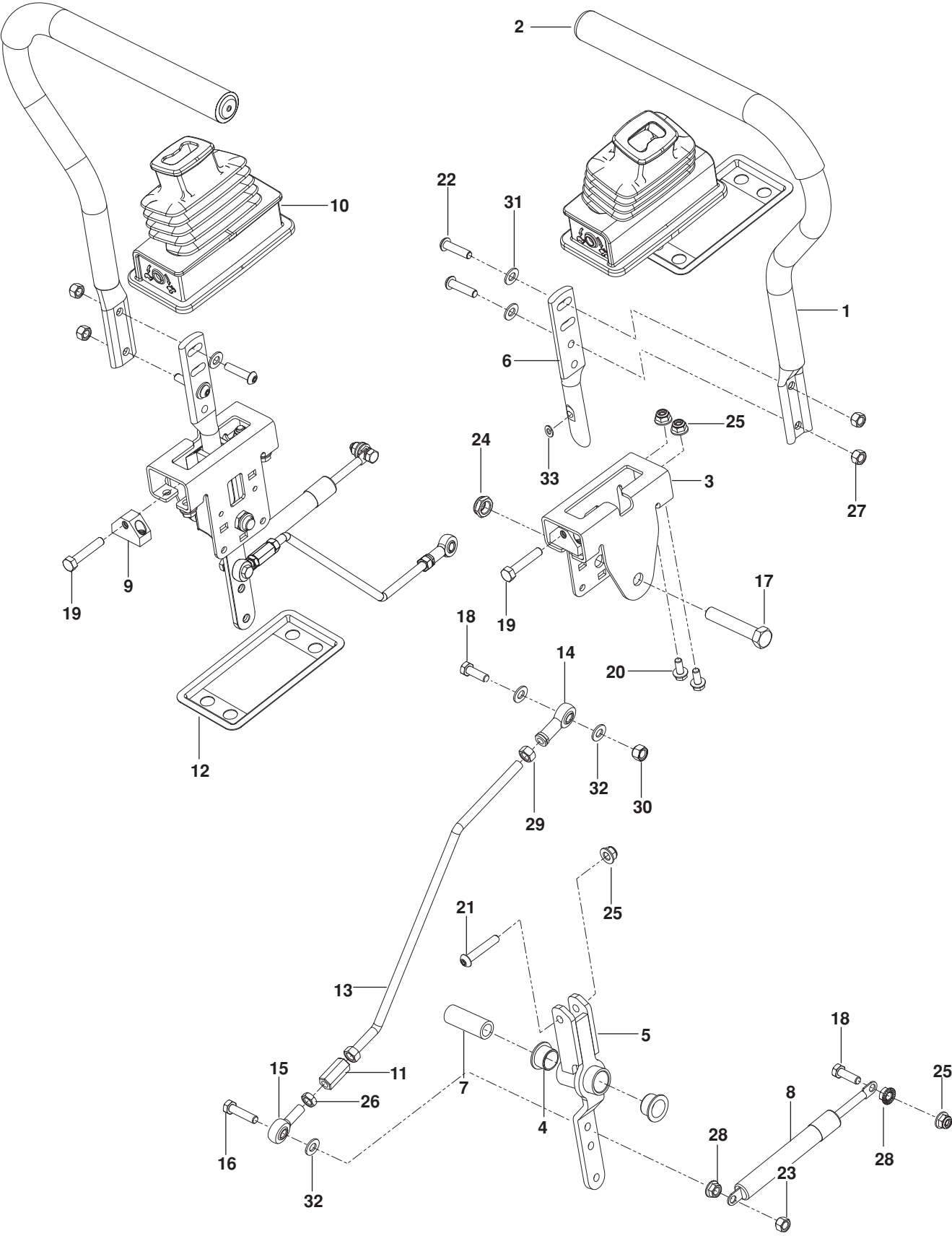

STEERING

ITEM	PART NO.	QTY.	DESCRIPTION	ITEM	PART NO.	QTY.	DESCRIPTION
1..	581 82 67-01.....	2.....	LEVER w/ GRIP	18..	874 78 05-16.....	4.....	BOLT ⁵ / ₁₆ -18 x 1 THD FRM
2..	525 39 29-01.....	2.....	GRIP, FOAM	19..	585 98 61-01.....	2.....	BOLT ⁵ / ₁₆ -18 x 1 ¹ / ₄
3..	585 12 47-02.....	2.....	BRACKET, CONTROL	20..	874 49 05-12.....	8.....	BOLT HEX FLG ⁵ / ₁₆ -18 X ³ / ₄
4..	539 13 15-18.....	4.....	BEARING	21..	576 85 04-02.....	2.....	SCREW ⁵ / ₁₆ -18 X 1 ³ / ₄ BTN HD
5..	576 14 03-01.....	2.....	LEVER, CONTROL	22..	585 98 59-01.....	4.....	SCREW ⁵ / ₁₆ -18 X 1 ¹ / ₄ BTN BLK
6..	587 60 17-02.....	2.....	LEVER, HANDLE	23..	873 80 05-00.....	2.....	NUT ⁵ / ₁₆ -18 HEX NYLOC
7..	584 92 72-01.....	2.....	SPACER, PIVOT CONTROL	24..	539 10 80-10.....	2.....	NUT ¹ / ₂ -13 HEX JAM NYL GR2
8..	539 10 27-20.....	2.....	DAMPENER	25..	539 11 28-99.....	12.....	NUT ⁵ / ₁₆ -18 HEX FLG NYLOC
9..	581 43 75-01.....	2.....	BLOCK, TRACKING	26..	873 70 05-00.....	2.....	NUT ⁵ / ₁₆ -24 HEX JAM LH
10..	585 83 16-01.....	2.....	BOOT, STEERING	27..	585 98 60-01.....	4.....	NUT ⁵ / ₁₆ -18 HEX NYLOC BLK
11..	539 11 66-89.....	2.....	COUPLER, ROD END	28..	539 99 05-85.....	4.....	NUT ⁵ / ₁₆ -18 HEX WHIZLK
12..	585 48 82-02.....	2.....	FLANGE, BOOT	29..	539 99 02-23.....	4.....	NUT ⁵ / ₁₆ -24 HEX
13..	580 62 42-01.....	2.....	ROD, MOTION CONTROL	30..	539 11 56-17.....	2.....	NUT ⁵ / ₁₆ -18 THIN NYLOC
14..	539 11 57-29.....	2.....	ROD END RH	31..	586 30 91-01.....	4.....	WASHER ⁵ / ₁₆ SAE FLT BLK
15..	539 11 66-90.....	2.....	ROD END MALE LH	32..	819 11 11-16.....	6.....	WASHER ⁵ / ₁₆ SAE FLT
16..	874 78 05-28.....	2.....	BOLT ⁵ / ₁₆ -18 x 1 ³ / ₄ TPBLT	33..	587 61 42-01.....	2.....	WASHER ¹¹ / ₃₂
17..	874 78 08-44.....	2.....	BOLT ¹ / ₂ -13 x 2 ³ / ₄				

IGNITION

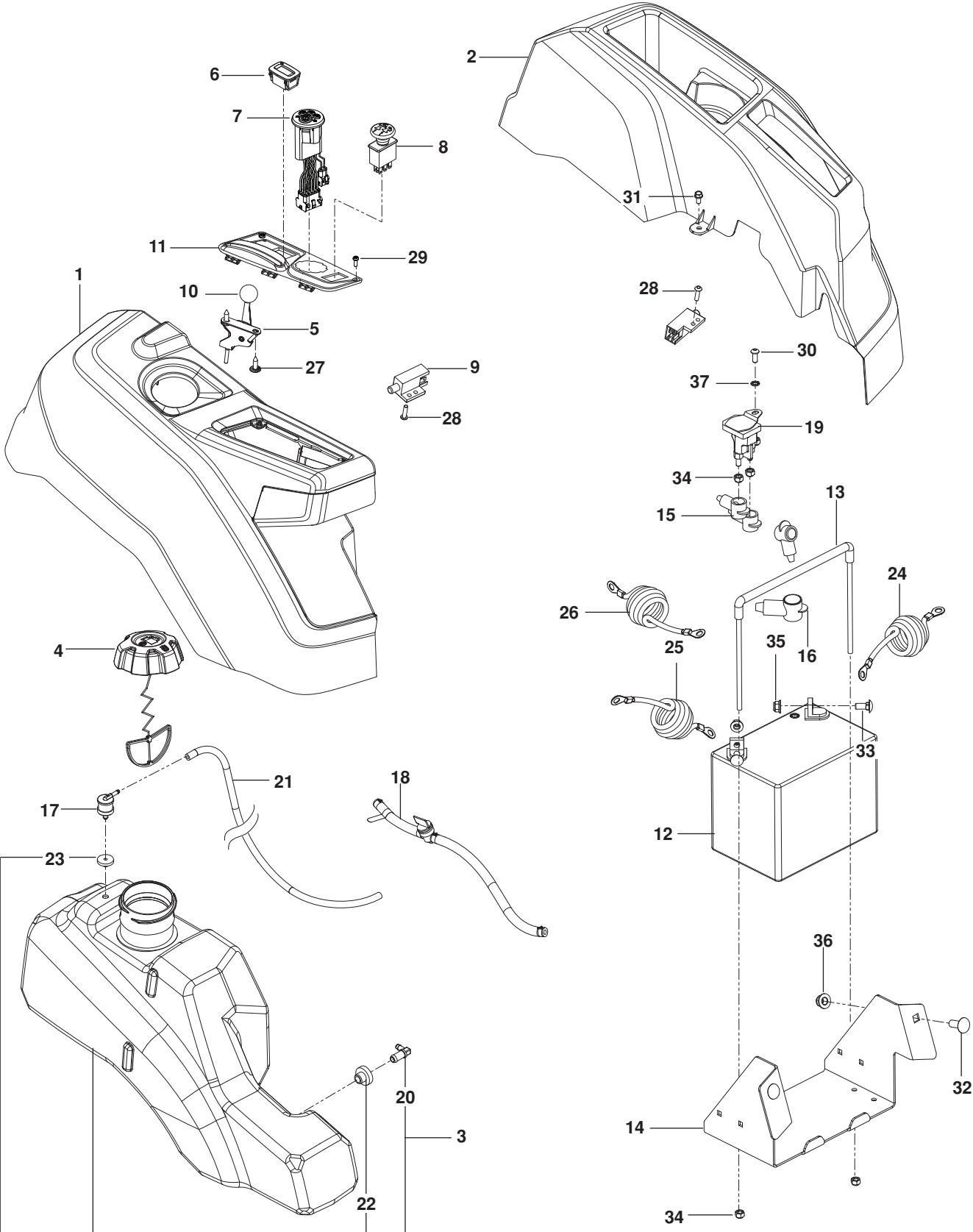

IGNITION

ITEM	PART NO.	QTY.	DESCRIPTION	ITEM	PART NO.	QTY.	DESCRIPTION
1..	585 52 28-01.....	1	ASSY, FENDER, RT GRY	21..	587 04 45-23.....	1	HOSE ³ / ₁₆ x 23" PURGE
2..	586 62 12-01.....	1	FENDER, LT GRY	22..	532 00 36-45.....	1	GROMMET, RUBBER
3..	578 18 06-02.....	1	ASSY, FUEL TANK	23..	532 43 74-92.....	1	GROMMET, CHECK VALVE
4..	585 12 48-01.....	1	CAP, FUEL w/ TETHER	24..	586 10 82-01.....	1	CABLE, BATTERY POSITIVE
5..	585 97 49-02.....	1	CABLE, THROTTLE	25..	585 30 69-04.....	1	CABLE, BATTERY NEGATIVE
6..	586 16 18-01.....	1	METER, SERVICE	26..	585 73 43-03.....	1	CABLE, BATTERY POSITIVE
7..	586 83 67-04.....	1	SWITCH, IGNITION	27..	532 14 18-41.....	2	SCREW 10-16 x .65
8..	532 17 46-52.....	1	SWITCH, PTO	28..	586 93 60-01.....	2	SCREW #10-24 x 1/2 SKT HD
9..	532 10 95-53.....	2	SWITCH, INTERLOCK	29..	545 22 71-01.....	2	SCREW 6-19 x 7/16 PAN HD
10..	539 13 30-49.....	1	KNOB	30..	539 11 12-29.....	1	SCREW 1/4-20 x 5/8 BTN SKT
11..	585 52 27-03.....	1	PANEL, CONTROL	31..	817 49 04-08.....	2	SCREW 1/4-20 x 1/2
12..	539 10 24-36.....	1	BATTERY	32..	539 99 06-45.....	2	BOLT 3/8-16 x 1 RDHD SQNK
13..	539 13 12-09.....	1	TIE DOWN, BATTERY	33..	872 14 05-06.....	2	BOLT 5/16-18 x 3/4 RDHD SQNK
14..	585 04 87-02.....	1	BOX, BATTERY BLK	34..	873 80 04-00.....	5	NUT 1/4-20 HEX NYLOC
15..	532 13 15-63.....	3	TERMINAL COVER	35..	539 11 28-99.....	2	NUT 5/16-18 FLANGE NYLOC
16..	539 10 27-59.....	1	INSULATOR	36..	521 99 65-01.....	2	NUT 3/8-16 HEX FLG NYLOC
17..	576 61 81-01.....	1	VALVE, FUEL CHECK	37..	539 99 00-53.....	1	WASHER 1/4 ITLW
18..	586 12 39-04.....	1	ASSY, FUEL LINE w/ VALVE	NOT SHOWN			
19..	532 19 25-07.....	1	SOLENOID		587 23 21-02	1	HARNESS, WIRING
20..	532 13 92-77.....	1	ELBOW		586 54 81-01	1	HARNESS, LED LIGHT

BRAKE / LIFT

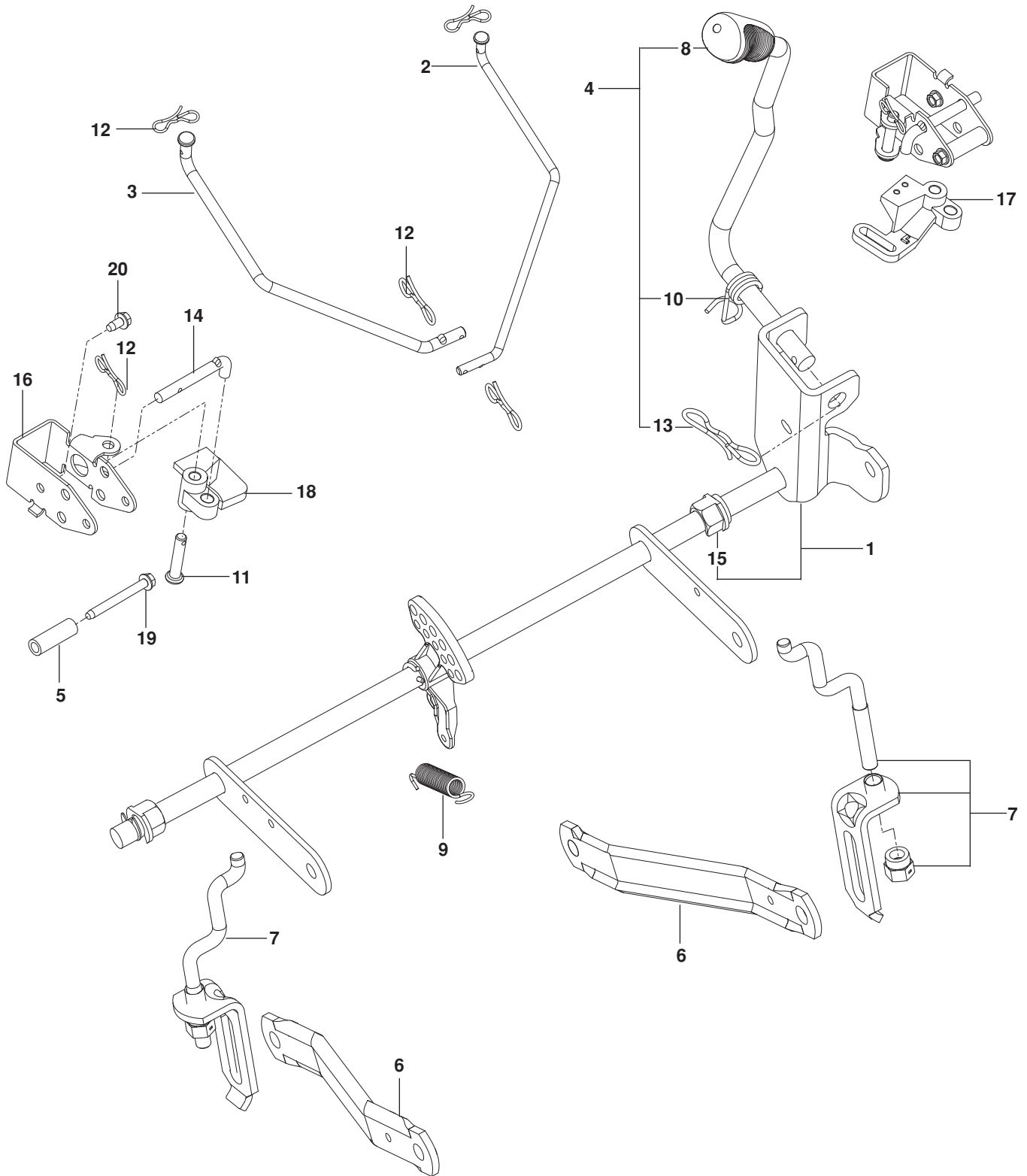

BRAKE / LIFT

ITEM	PART NO.	QTY.	DESCRIPTION	ITEM	PART NO.	QTY.	DESCRIPTION
1..	587 62 31-01.....	1	ASSY, SHAFT w/ NUTS, E-RINGS	11..	585 70 14-01.....	2	PIN ½ CLEVIS
2..	586 45 71-01.....	1	LINK, BRAKE LT	12..	587 22 53-01.....	6	CLIP
3..	586 45 72-01.....	1	LINK, BRAKE RT	13..	532 19 42-09.....	1	CLIP
4..	587 62 29-01.....	1	ASSY, LIFT HANDLE	14..	585 68 20-01.....	2	PUSHROD
5..	580 48 61-01.....	2	SPACER	15..	510 18 49-01.....	2	NUT, PLASTIC
6..	532 19 51-85.....	2	ARM, SUSPENSION RR	16..	585 68 21-01.....	2	BRACKET, BELLCRANK
7..	587 62 30-01.....	2	ASSY, CENTERING LNK	17..	586 45 74-01.....	1	BELLCRANK LT
8..	532 44 50-60.....	1	GRIP, HANDLE	18..	586 45 75-01.....	1	BELLCRANK RT
9..	586 86 76-01.....	1	SPRING	19..	586 56 13-01.....	2	SCREW ¼-20 x 2¼ THD ROLL
10..	532 19 63-14.....	1	SPRING	20..	532 13 77-29.....	2	SCREW ¼-20 x 5/8 THD ROLL

HYDRAULIC PUMP - MOTOR

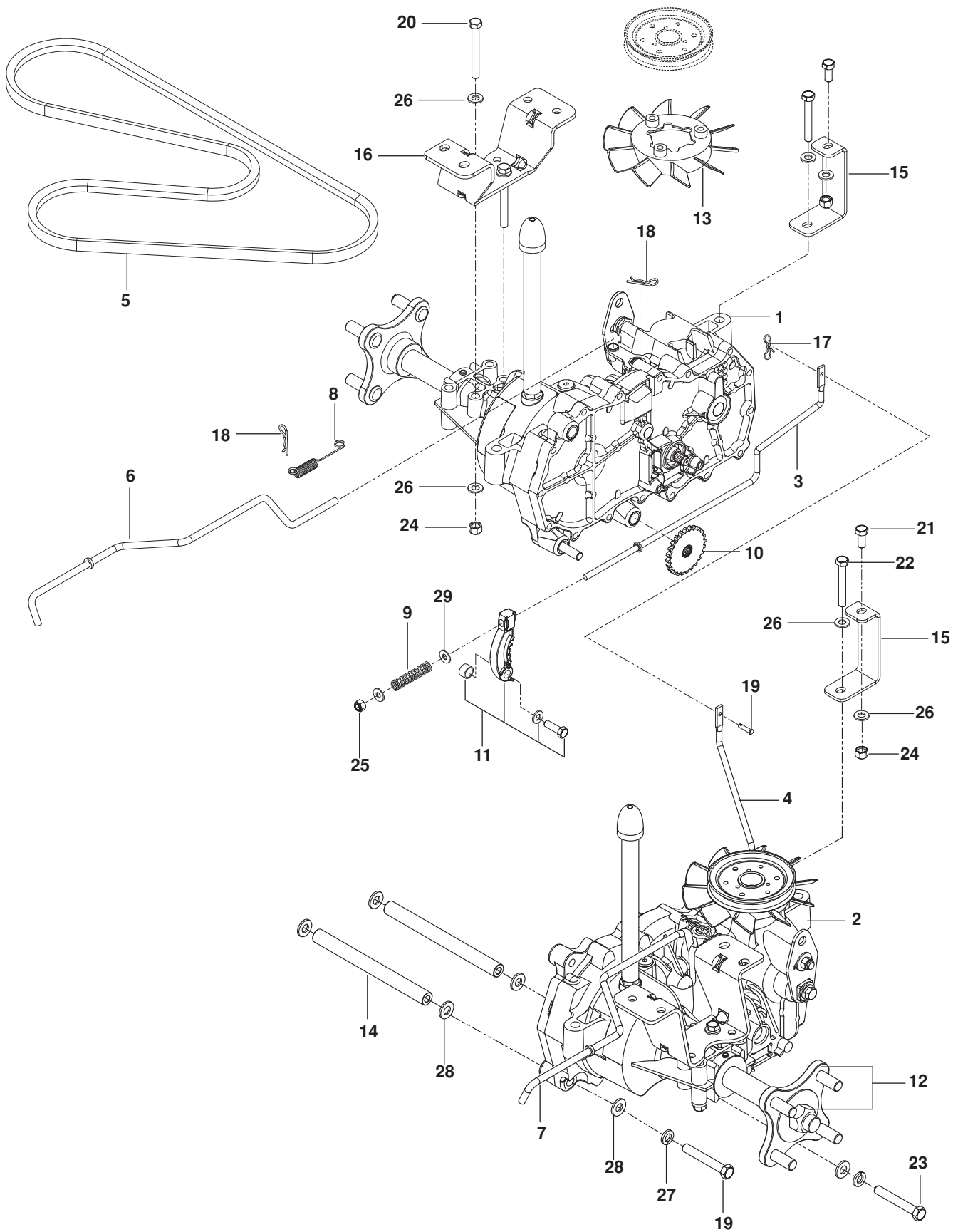

HYDRAULIC PUMP-MOTOR

ITEM	PART NO.	QTY.	DESCRIPTION	ITEM	PART NO.	QTY.	DESCRIPTION
1..	510 37 56-01.....	1	EZT, LT	16..	580 80 66-02.....	2	MOUNT, EZT RR BLK
2..	510 37 56-02.....	1	EZT, RT	17..	587 22 53-01.....	1	CLIP
3..	574 03 05-01.....	1	ROD, EZT BRAKE LT	18..	539 97 69-88.....	4	CLIP
4..	574 03 05-02.....	1	ROD, EZT BRAKE RT	19..	587 11 53-01.....	1	PIN, CLEVIS
5..	539 11 04-11.....	1	BELT, EZT	20..	874 78 05-44.....	4	BOLT ⁵ / ₁₆ -18 x 2 ³ / ₄
6..	585 47 44-01.....	1	ROD, BYPASS LT	21..	874 78 05-12.....	2	BOLT ⁵ / ₁₆ -18 x ³ / ₄
7..	585 47 45-01.....	1	ROD, BYPASS RT	22..	874 78 05-36.....	2	BOLT ⁵ / ₁₆ -18 x 2 ¹ / ₄
8..	586 66 51-01.....	2	SPRING, BYPASS	23..	874 78 06-40.....	4	BOLT ³ / ₈ -16 x 2 ¹ / ₂
9..	539 11 03-42.....	2	SPRING, BRAKE ROD	24..	873 80 05-00.....	8	NUT ⁵ / ₁₆ -18 HEX NYLOC
10..	539 12 00-80.....	2	COG, BRAKE DISC	25..	873 80 04-00.....	2	NUT ¹ / ₄ -20 HEX NYLOC
11..	539 12 00-79.....	2	ASSY, BRAKE ARM	26..	819 11 11-16.....	16	WASHER ⁵ / ₁₆ SAE FLT
12..	575 50 70-01.....	1	ASSY, HUB w/ NUTS	27..	810 03 06-00.....	4	WASHER ³ / ₈ SPLT LCK
13..	539 12 07-85.....	2	BLADE, FAN	28..	819 13 13-16.....	8	WASHER ³ / ₈ SAE FLT
14..	510 18 41-04.....	2	SPACER TUBE	29..	819 09 10-16.....	4	WASHER ¹ / ₄ SAE FLT
15..	580 80 65-02.....	2	SUPPORT, EZT FRT				

WHEELS AND TIRES

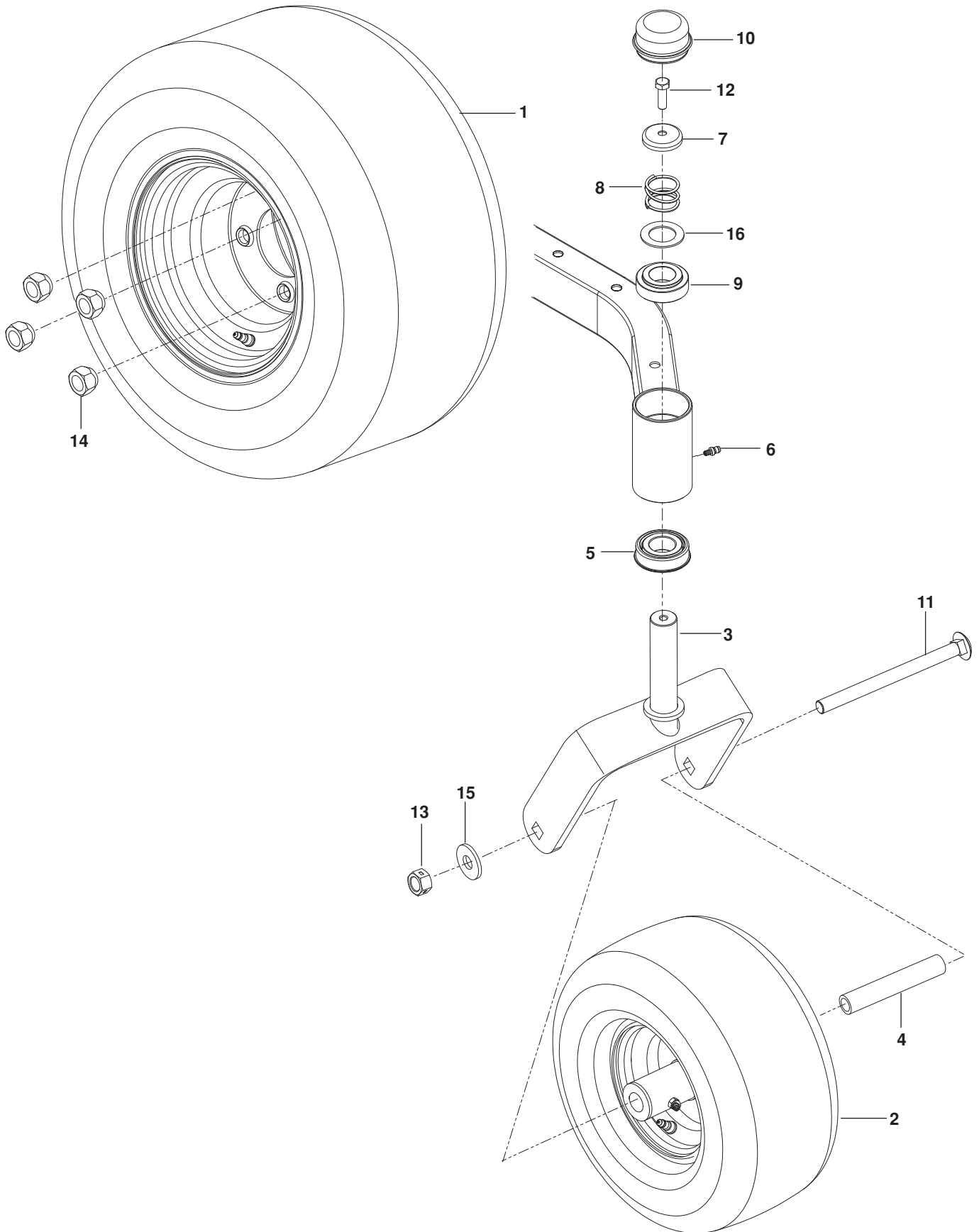

WHEELS AND TIRES

ITEM	PART NO.	QTY.	DESCRIPTION	ITEM	PART NO.	QTY.	DESCRIPTION
1..	579 75 34-01.....	2.....	ASSY, WHEEL REAR 18 x 9.5	9..	539 11 79-01.....	2.....	BUSHING, CASTER
2..	576 58 86-02.....	2.....	ASSY, CASTER TIRE 11 x 6-5	10..	539 10 25-35.....	1.....	CAP, GREASE
3..	576 58 88-01.....	2.....	YOKE, ORG	11..	576 60 15-01.....	2.....	BOLT 1/2-13 x 7 1/2 RD HD SQNK
4..	576 58 89-01.....	2.....	SPACER, PIVOT	12..	874 95 05-16.....	2.....	BOLT 5/16-18 x 1 w/ NYLON
5..	539 11 26-60.....	2.....	BEARING, FLANGED	13..	873 93 08-00.....	2.....	NUT 1/2 HEX CNTRLK
6..	539 11 56-38.....	2.....	ZERK 3/16 DRIVE	14..	539 10 11-73.....	8.....	NUT 1/2 LUG
7..	539 11 57-49.....	2.....	PLUG, CASTER	15..	539 11 56-75.....	2.....	WASHER
8..	539 11 57-47.....	2.....	SPRING, CASTER	16..	819 18 22-12.....	2.....	WASHER 1/2 FLT

MOWER DECK / CUTTING DECK

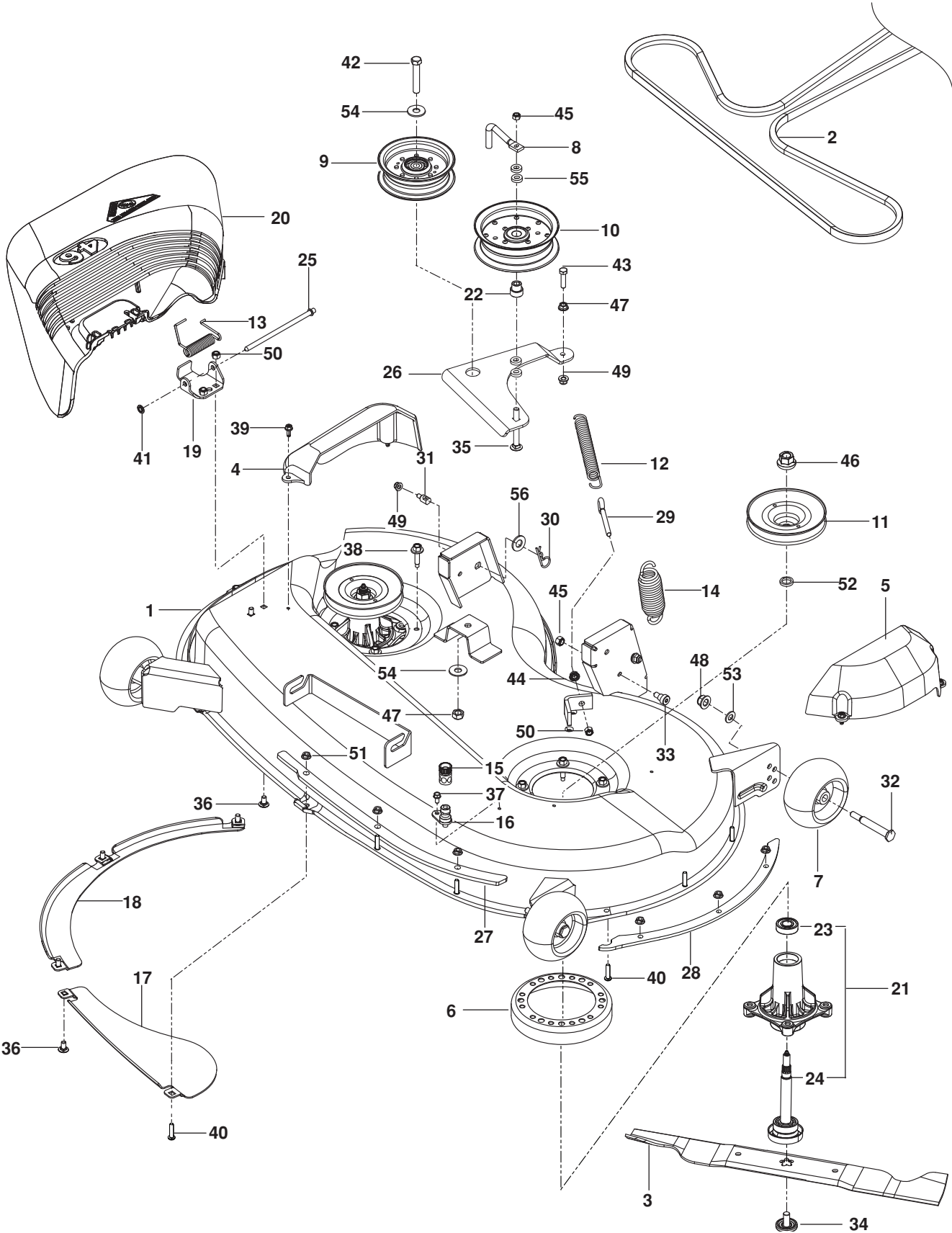

MOWER DECK / CUTTING DECK

ITEM	PART NO.	QTY.	DESCRIPTION	ITEM	PART NO.	QTY.	DESCRIPTION
1..	581 07 10-01.....	1	DECK w/ SAFETY DECALS	29..	539 11 55-74.....	1	EYEBOLT $\frac{5}{16}$ x $3\frac{1}{2}$
2..	539 11 72-45.....	1	BELT, DECK	30..	539 97 69-89.....	2	HAIRPIN
3..	532 40 53-80.....	2	BLADE, HI-LIFT	31..	532 19 51-61.....	2	STUD w/ANTI- ROTATE
4..	532 40 55-06.....	1	SHIELD, BELT RH	32..	532 19 34-06.....	3	BOLT $\frac{3}{8}$ -16 x $3\frac{5}{8}$ SHOULDER
5..	532 40 55-07.....	1	SHIELD, BELT LH	33..	539 11 36-21.....	2	BOLT $\frac{3}{8}$ -16 x $\frac{3}{8}$ SHOULDER
6..	532 17 44-93.....	2	STRIPPER, UNIVERSAL	34..	532 19 30-03.....	2	BOLT, WASHER
7..	532 17 48-73.....	3	WHEEL, GAUGE	35..	539 12 81-01.....	1	BOLT $\frac{3}{8}$ -16 x $2\frac{1}{4}$ RD HD SQNK
8..	522 62 97-01.....	1	KEEPER, BELT	36..	872 14 05-06.....	6	BOLT $\frac{5}{16}$ -18 x $\frac{3}{4}$ RD HD SQNK
9..	532 19 61-04.....	1	PULLEY, IDLER	37..	539 99 10-34.....	1	SCREW 10-24 x $\frac{5}{8}$ WSH HD
10..	539 13 27-28.....	1	PULLEY, IDLER	38..	532 17 39-84.....	8	SCREW $\frac{5}{16}$ -18 WSH HD
11..	539 11 39-62.....	2	PULLEY, DECK	39..	532 13 77-29.....	4	SCREW $\frac{1}{4}$ -20 x $\frac{5}{8}$ THDROLL
12..	539 12 09-20.....	1	SPRING, DECK BELT	40..	578 29 64-04.....	6	SCREW $\frac{1}{4}$ -20 BTN HD
13..	532 17 81-02.....	1	SPRING, TORSION	41..	532 11 04-52.....	1	PUSHNUT
14..	539 11 87-62.....	1	SPRING	42..	874 78 07-40.....	1	BOLT $\frac{7}{16}$ -14 x $2\frac{1}{2}$ HEX HD
15..	532 41 64-05.....	1	COUPLING, CONNECT	43..	874 78 05-20.....	1	BOLT $\frac{5}{16}$ -18 x $1\frac{1}{4}$ HEX HD
16..	532 41 55-98.....	1	PORT, WASHOUT	44..	539 99 05-85.....	2	NUT $\frac{5}{16}$ -18 HEX WHIZLK
17..	532 40 31-49.....	1	BAFFLE, FRONT	45..	539 20 02-82.....	3	NUT $\frac{3}{8}$ -16 HEX JAM NYLOC
18..	532 40 31-50.....	1	BAFFLE, FRONT RH	46..	532 40 02-34.....	2	NUT $\frac{9}{16}$ TOP CNTRLK
19..	532 19 25-57.....	1	BRACKET, DEFLECTOR	47..	539 11 91-24.....	1	NUT $\frac{7}{16}$ -14 HEX NYLOC
20..	532 40 53-57.....	1	SHIELD, DEFLECTOR	48..	873 90 06-00.....	3	NUT $\frac{3}{8}$ -16 FLG LK
21..	532 17 43-56.....	2	CUTTER HOUSING	49..	539 11 28-99.....	3	NUT $\frac{5}{16}$ -18 HEX FLG NYLOC
22..	539 11 20-76.....	1	BUSHING, IDLER	50..	873 80 05-00.....	8	NUT $\frac{5}{16}$ -18 HEX NYLOC
23..	532 11 04-85.....	1	BEARING	51..	873 90 04-00.....	6	NUT $\frac{1}{4}$ -20 HEX FLG
24..	532 17 43-60.....	1	SHAFT	52..	532 18 76-90.....	2	WASHER, SPACER
25..	532 13 14-91.....	1	ROD, HINGE	53..	819 13 20-12.....	3	WASHER 12 GA
26..	574 68 90-02.....	1	ARM, IDLER	54..	539 10 48-64.....	2	WASHER $\frac{7}{16}$ FLT
27..	585 31 77-05.....	1	PLATE FRT	55..	539 10 95-62.....	4	WASHER $\frac{3}{8}$
28..	585 31 78-05.....	1	PLATE, SIDE	56..	819 21 21-13.....	2	WASHER $\frac{5}{8}$ SAE FLT

SEAT

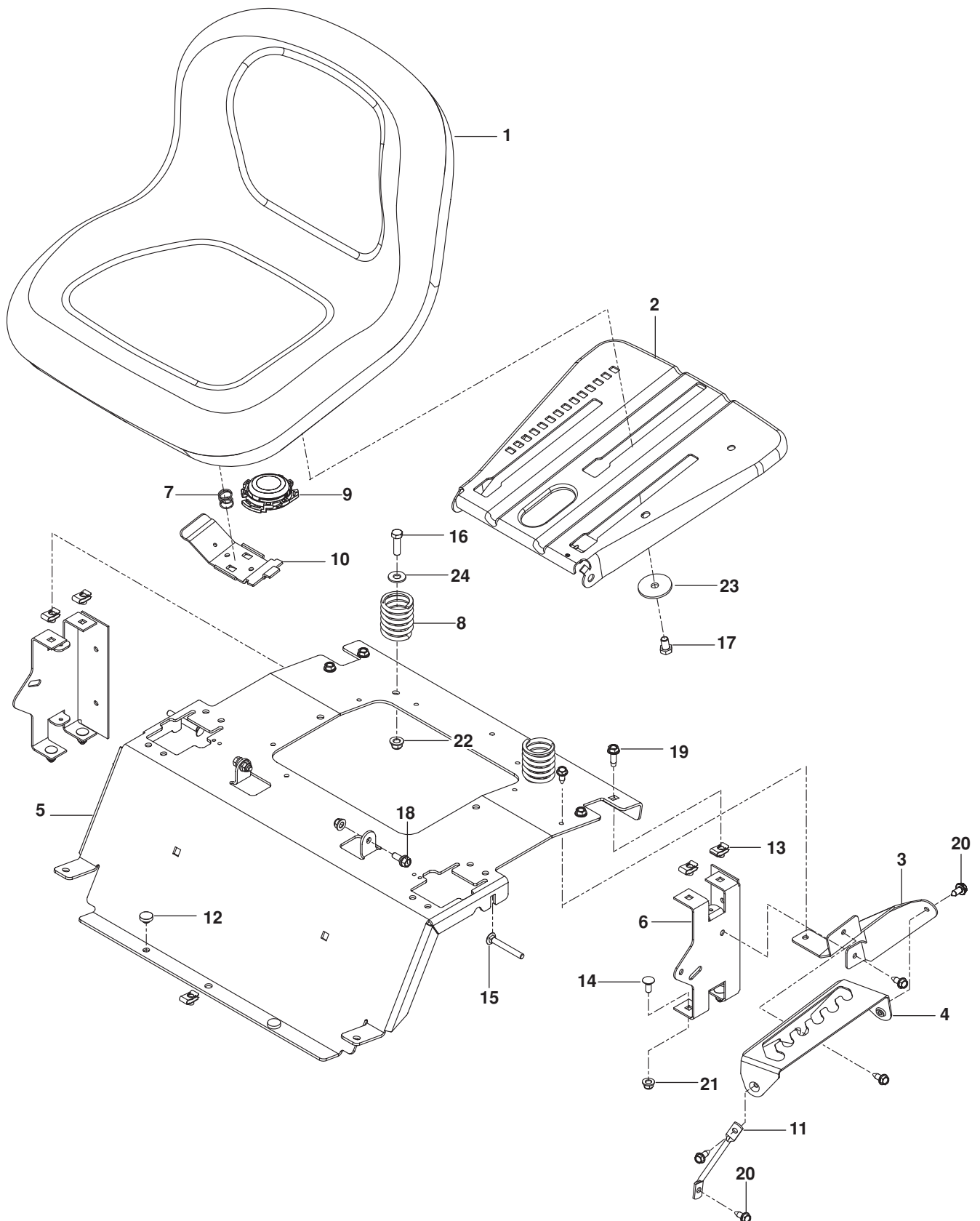

SEAT

ITEM	PART NO.	QTY.	DESCRIPTION	ITEM	PART NO.	QTY.	DESCRIPTION
1..	532 43 98-22.....	1	SEAT	13..	539 10 47-63.....	5	RETAINER, U TYPE
2..	532 19 69-77.....	1	PAN, SEAT	14..	872 14 05-06.....	4	BOLT ⁵ / ₁₆ -18 x ³ / ₄ RDHD SQNK
3..	586 22 08-02.....	1	PLATE, LIFT SUPPORT	15..	510 42 27-01.....	2	BOLT ⁵ / ₁₆ -18 x 2 ¹ / ₂ RDHD SQNK
4..	586 22 12-02.....	1	PLATE, DECK LIFT	16..	874 78 06-20.....	2	BOLT ³ / ₈ -16 x 1 ¹ / ₄
5..	577 26 05-03	1	SUPPORT, SEAT ORG	17..	874 78 06-10.....	1	BOLT ³ / ₈ -16 x ⁵ / ₈
6..	580 30 82-02.....	2	SUPPORT, SEAT RR BLK	18..	539 11 03-03.....	2	BOLT ⁵ / ₁₆ -18 SHOULDER
7..	581 42 93-02.....	1	SPRING, LATCH	19..	817 49 05-12.....	4	SCREW ⁵ / ₁₆ -18 x ³ / ₄ THD FRM
8..	532 12 41-81.....	2	SPRING, SEAT	20..	817 00 05-10.....	6	SCREW ⁵ / ₁₆ -18 x ⁵ / ₈ WSH HD
9..	532 40 15-85.....	1	SWITCH, SEAT	21..	539 11 28-99.....	4	NUT ⁵ / ₁₆ -18 HEX FLG NYLOC
10..	532 19 76-61.....	1	HANDLE, SLIDE	22..	521 99 65-01.....	2	NUT ³ / ₈ -16 HEX FLG NYLOC
11..	586 42 86-01.....	1	LEG, SUPPORT	23..	539 11 18-97.....	1	WASHER ³ / ₈ SPECIAL
12..	585 98 93-01.....	2	GROMMET, BUMPER	24..	819 14 16-14.....	2	WASHER ³ / ₈ STD FLT

DECALS

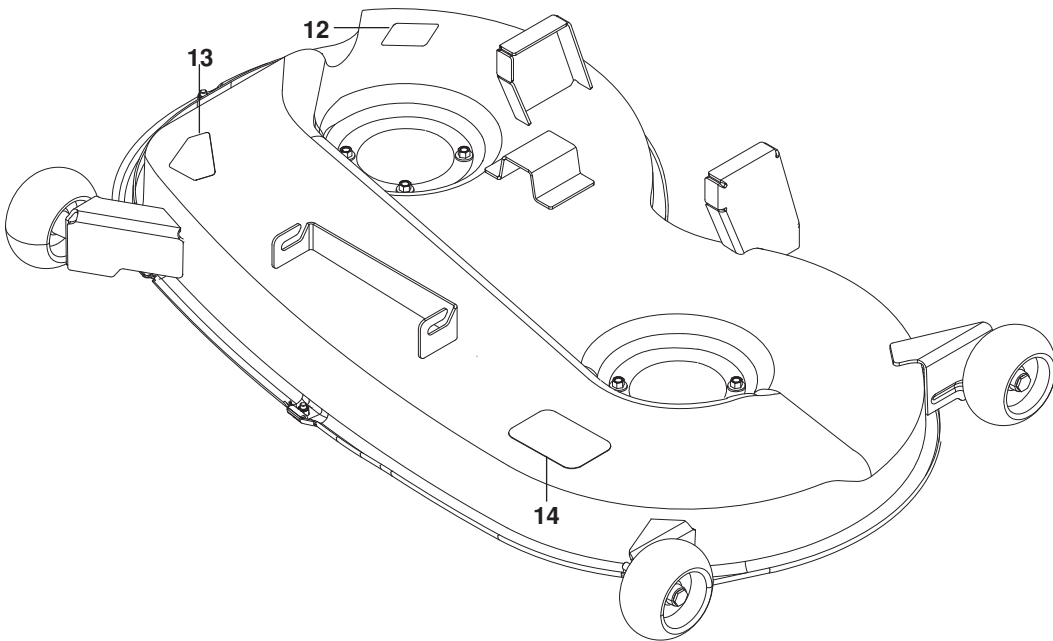
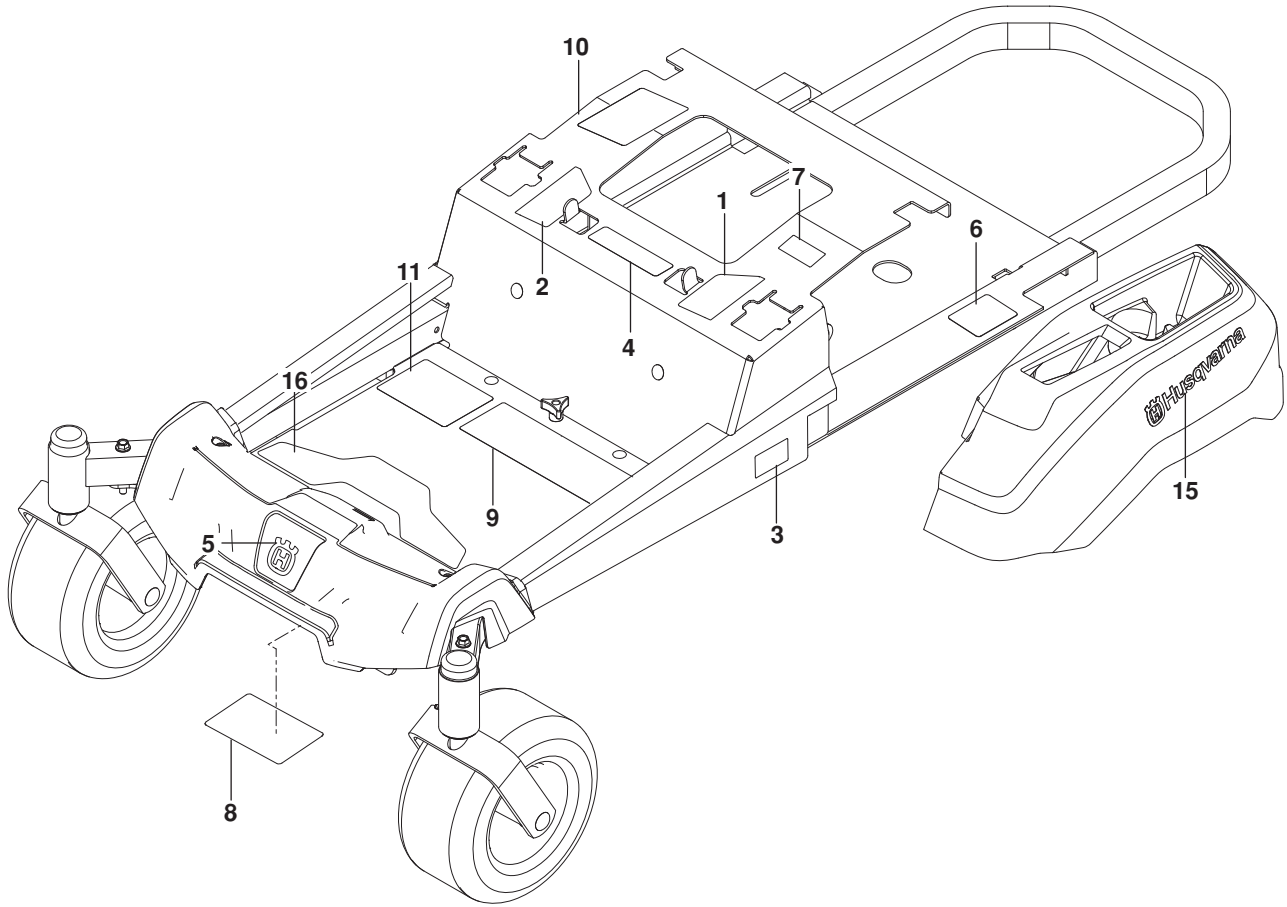

DECALS

ITEM	PART NO.	QTY.	DESCRIPTION	ITEM	PART NO.	QTY.	DESCRIPTION
1..	587 59 56-01.....	1	DECAL, STEER / BRAKE LT	9..	539 10 99-08.....	1	DECAL, SAFETY WARNINGS
2..	587 59 55-01.....	1	DECAL, STEER / BRAKE RT	10..	532 42 38-29.....	1	DECAL, RESPONSIBILITY
3..	587 86 55-01.....	2	DECAL, Z 246i	11..	588 03 52-01.....	1	DECAL, START
4..	539 10 57-45.....	1	DECAL, BATTERY WARNING	12..	581 72 44-01.....	1	DECAL, DEFLECTOR
5..	532 42 86-77.....	1	DECAL, CROWN	13..	584 90 46-01.....	1	DECAL, BLADE DANGER
6..	539 10 83-85.....	1	DECAL, DO NOT TOW	14..	510 24 02-01.....	1	DECAL, BELT ROUTING
7..	539 10 83-86.....	1	DECAL, EXIT MOWER	15..	577 46 90-01.....	2	DECAL, HUSQVARNA
8..	539 10 98-97.....	1	DECAL, SERVICE	16..	587 00 07-01.....	1	ABRASIVE PAD

ACCESSORIES

BAGGER

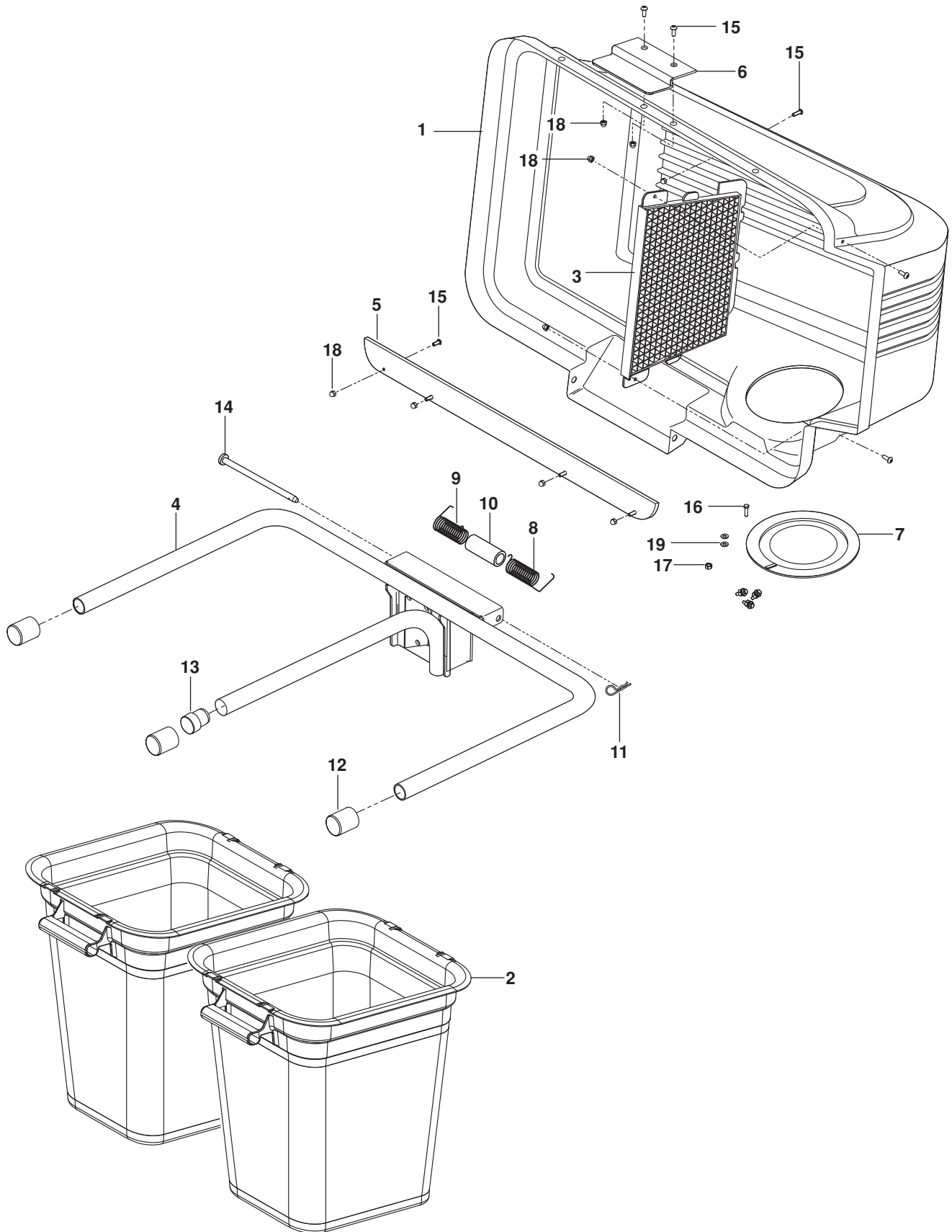

ACCESSORIES

ITEM	PART NO.	QTY.	DESCRIPTION
1..	539 11 11-39.....	1	COVER ASSY, COMPLETE
2..	532 40 02-26.....	2	CONTAINER, SOFT BAG
3..	532 12 75-33.....	1	SCREEN, COVER
4..	532 17 97-46.....	1	BAGGER, FRAME
5..	532 15 50-42.....	1	STRIP, REINFORCEMENT
6..	532 13 08-95.....	1	LATCH HANDLE, COVER
7..	532 12 75-34.....	1	GASKET
8..	532 13 27-96.....	1	SPRING, COVER LH
9..	532 13 29-83.....	1	SPRING, COVER RH
10..	532 13 32-35.....	1	SPACER, COVER

ITEM	PART NO.	QTY.	DESCRIPTION
11..	539 10 80-96.....	1	HAIRPIN, RETAINER
12..	539 10 80-97.....	3	CAP, TUBING END
13..	522 80 13-01.....	1	SPACER PLUG
14..	532 19 27-86.....	1	PIN, HINGE
15..	539 97 69-52.....	9	SCREW #10-24 x ⁵ / ₈
16..	539 10 63-12.....	4	SCREW #10-24 x ³ / ₄
17..	539 97 69-77.....	4	NUT #10-24 HEX NYLOC
18..	539 10 80-86.....	9	NUT #10-24 ACORN
19..	819 07 08-18.....	8	WASHER #10 FLAT

ACCESSORIES

CHUTES, MOUNT

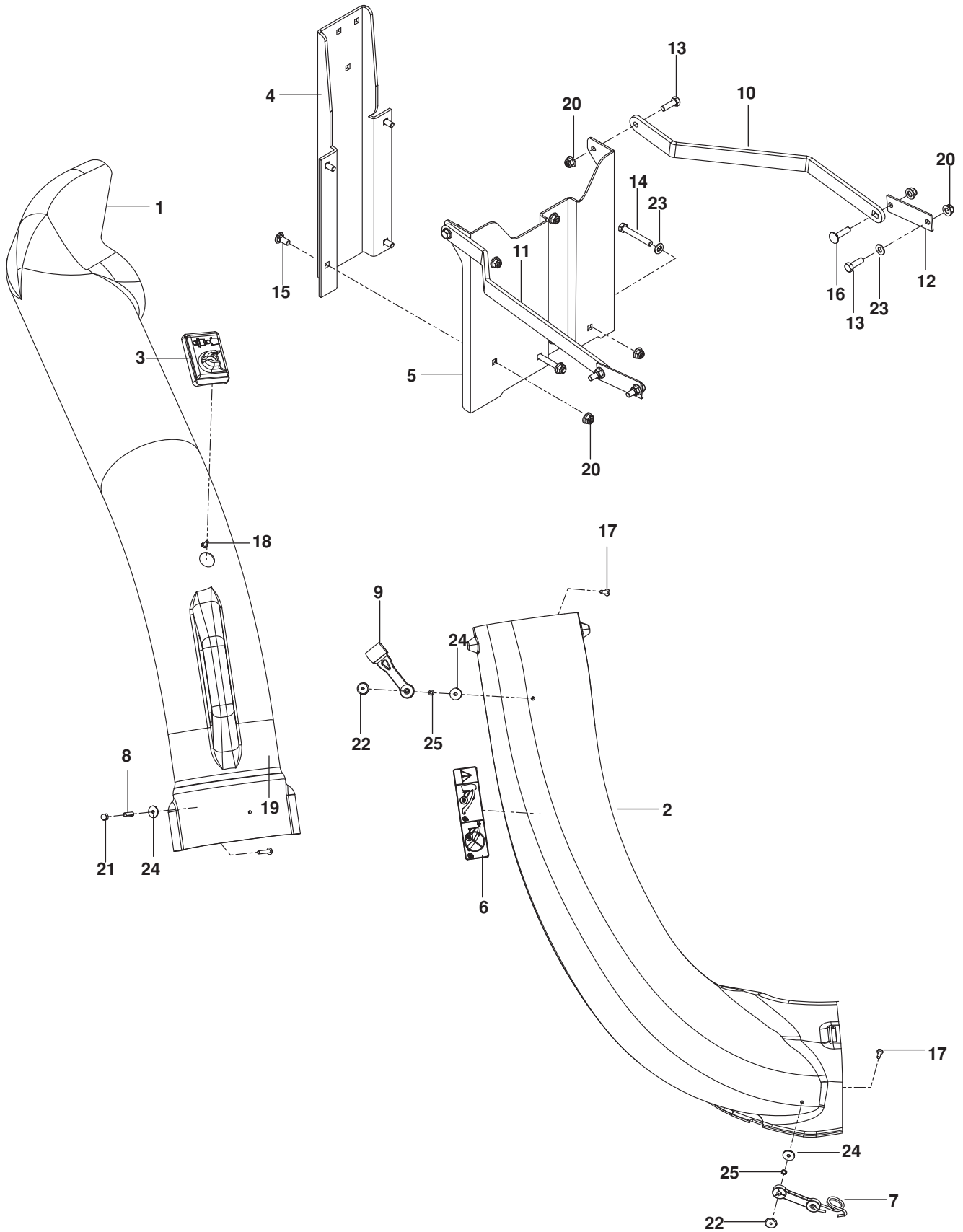

ACCESSORIES

ITEM	PART NO.	QTY.	DESCRIPTION	ITEM	PART NO.	QTY.	DESCRIPTION
1..	525 49 70-01.....	1	CHUTE, UPPER	14..	874 78 05-36.....	8	BOLT $\frac{5}{16}$ -18 x $2\frac{1}{4}$
2..	532 40 54-55.....	1	CHUTE, LOWER	15..	539 99 03-16.....	4	BOLT $\frac{5}{16}$ -18 x $\frac{3}{4}$ RDHD SQNK
3..	539 10 80-82.....	1	INDICATOR, BAG DUMP	16..	539 10 04-72.....	2	BOLT $\frac{5}{16}$ -18 x $1\frac{1}{4}$ RDHD SQNK
4..	522 85 47-02.....	1	BRACKET, HANGER	17..	539 97 69-52.....	3	SCREW #10-24 x $\frac{5}{8}$
5..	522 85 46-02.....	1	BRACKET, COLLECTION	18..	539 10 80-81.....	1	SCREW #10-14 x $\frac{1}{2}$
6..	539 10 81-63.....	1	DECAL, CATCHER	19..	539 10 80-83.....	1	SCREW #10-24 x $1\frac{1}{8}$
7..	539 10 81-94.....	2	LATCH ASSM, CHUTE	20..	539 11 28-99.....	12	NUT $\frac{5}{16}$ -18 HEX FLG NYLOC
8..	539 10 80-85.....	1	SPACER, SPLIT	21..	539 10 80-86.....	1	NUT #10-24 ACORN
9..	539 10 80-88.....	1	LATCH, HOOD	22..	539 10 80-89.....	3	NUT #10-24 WELD PLATED
10..	522 85 45-02.....	1	STRAP, SUPPORT, LT	23..	819 11 11-16.....	6	WASHER $\frac{5}{16}$ SAE FLAT
11..	522 85 44-02.....	1	STRAP, SUPPORT, RT	24..	539 10 80-84.....	4	WASHER $\frac{3}{16}$ x $\frac{3}{4}$ 16 GA
12..	523 11 28-02.....	2	PLATE	25..	539 10 95-52.....	3	WASHER $\frac{3}{16}$ LK
13..	874 78 05-16.....	4	BOLT $\frac{5}{16}$ -18 x 1				

www.husqvarna.com

115 73 83-27 Rev B
2015-01-30