

Gasoline containing up to 10% ethanol (E10) is acceptable for use in this machine. The use of any gasoline exceeding 10% ethanol (E10) will void the product warranty.

Parts Manual

Z 254 / 967324101



Please read the operator manual carefully and make sure you understand the instructions before using the machine.

When you need spare parts or support in service questions, warranty issues, etc., please consult the following professional:

This manual belongs to the machine with the manufacturing number:	Engine	Transmission

Manufacturing Number

The machine's manufacturing number can be found on the printed plate affixed to the engine compartment.

Stated on the plate, from the top are:

- The machine's type designation (I.D.).
- The manufacturer's type number (Model).
- The machine's serial number (Serial no.)

Please have the type designation and serial number available when ordering spare parts.

The engine's manufacturing number is stamped on one of the valve covers.

The plate states:

- The engine's model.
- The engine's type.
- Code

Please have these available when ordering spare parts.

The wheel motors and hydrostatic pumps have a barcode decal affixed at the rear.

CONTENTS

FRAME.....	4
ENGINE PLATE.....	6
STEERING	8
IGNITION.....	10
BRAKE / LIFT.....	12
HYDRAULIC PUMP - MOTOR.....	14
WHEELS AND TIRES.....	16
MOWER DECK / CUTTING DECK.....	18
SEAT	20
DECALS.....	22

Illustrations may or may not represent the actual assemblies and it is not recommended to use this manual as a guide to assemble or disassemble the mower.

NOTE: All fasteners are Grade 5 unless otherwise specified.

FRAME

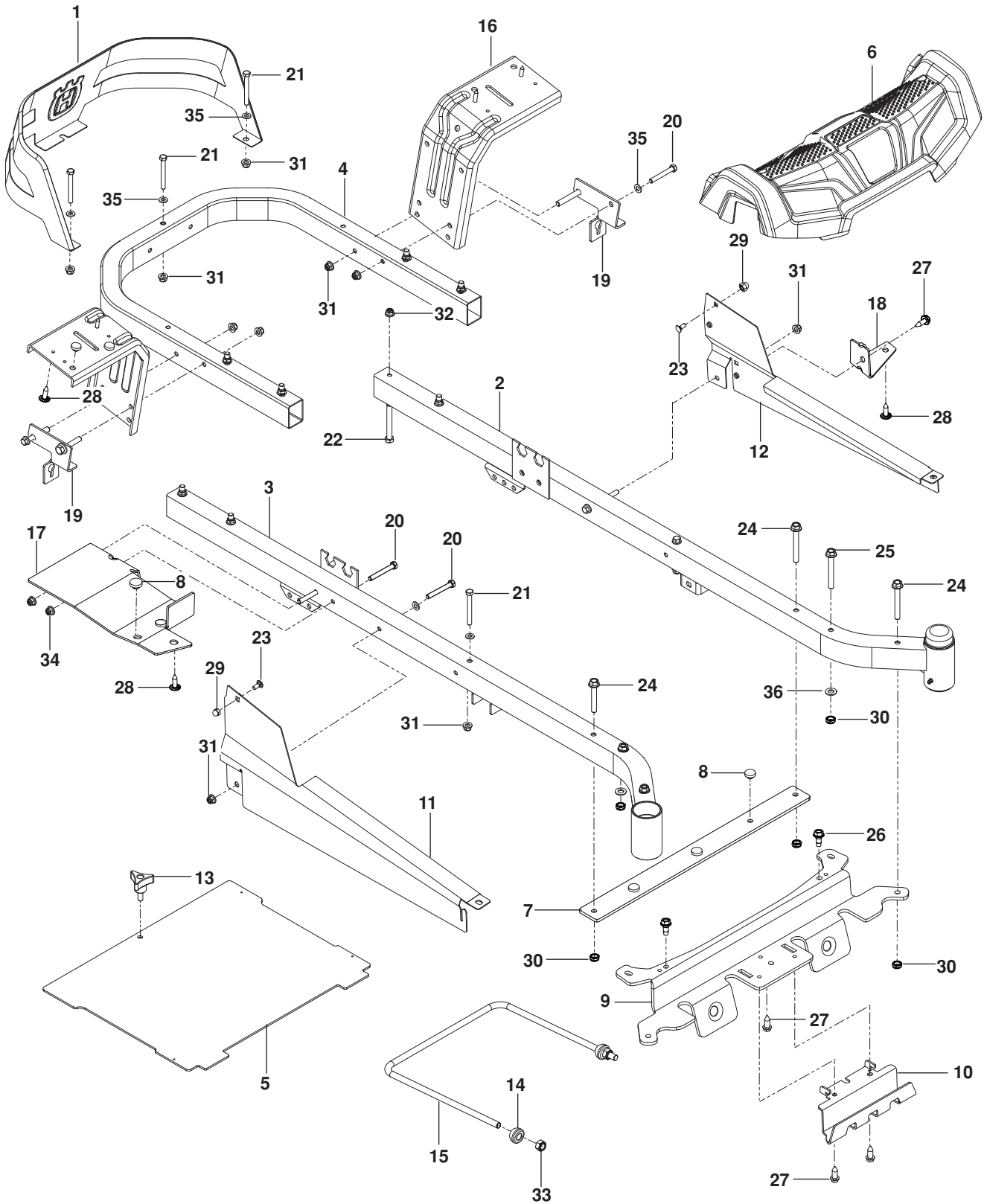

FRAME

ITEM	PART NO.	QTY.	DESCRIPTION	ITEM	PART NO.	QTY.	DESCRIPTION
1..	585 03 98-02.....	1	GUARD, REAR BLK	19..	585 47 43-02.....	2	BRACKET, BYPASS ROD
2..	510 17 75-03.....	1	FRAME, FRONT RT ORG	20..	874 78 05-36.....	8	BOLT $\frac{5}{16}$ -18 x 2 $\frac{1}{4}$
3..	510 17 74-03.....	1	FRAME, FRONT LT ORG	21..	874 78 05-44.....	5	BOLT $\frac{5}{16}$ -18 x 2 $\frac{3}{4}$
4..	584 99 10-02.....	1	FRAME, REAR TUBE ORG	22..	874 78 06-48.....	8	BOLT $\frac{3}{8}$ -16 x 3
5..	522 84 29-02.....	1	FOOT PLATE w/ SAFETY DECAL	23..	585 94 00-01.....	2	BOLT $\frac{5}{16}$ -18 x 1 CARRIAGE
6..	585 52 24-01.....	1	COVER, FOOTREST	24..	577 11 77-01.....	4	BOLT $\frac{3}{8}$ -16 x 3
7..	585 52 30-04.....	1	SUPPORT, FOOTREST	25..	586 65 43-01.....	2	BOLT $\frac{3}{8}$ -16 x 3 SHOULDER
8..	585 98 93-01.....	7	GROMMET, BUMPER	26..	586 88 11-01.....	2	BOLT $\frac{5}{16}$ -18 SHOULDER
9..	585 52 31-04.....	1	CROSS MEMBER	27..	817 00 05-10.....	4	SCREW $\frac{5}{16}$ -18 x $\frac{5}{8}$ WSH HD
10..	585 52 32-02.....	1	PLATE, SKID	28..	532 41 63-58.....	6	SCREW #10-24 x $\frac{3}{4}$ HEX HD
11..	585 33 16-02.....	1	COVER, RAIL RT	29..	585 93 81-01.....	2	NUT $\frac{5}{16}$ -18 ACORN
12..	585 33 15-02.....	1	COVER, RAIL LT	30..	539 20 02-82.....	6	NUT $\frac{3}{8}$ -16 HEX JAM NYLOC
13..	539 10 44-11.....	1	KNOB w/ STUD	31..	539 11 28-99.....	9	NUT $\frac{5}{16}$ -18 HEX FLG NYLOC
14..	532 19 52-63.....	2	BUSHING, PIVOT	32..	521 99 65-01.....	8	NUT $\frac{3}{8}$ -16 HEX FLG NYLOC
15..	521 93 81-01.....	1	LINK, FRONT SUSPENSION	33..	539 11 91-24.....	2	NUT $\frac{7}{16}$ -14 HEX NYLOC
16..	580 50 13-02.....	2	SUPPORT, FENDER BLK	34..	873 90 05-00.....	2	NUT $\frac{5}{16}$ -18 HEX FLG LK
17..	585 52 34-04.....	1	SUPPORT, CONSOLE RT	35..	819 11 11-16.....	11	WASHER $\frac{5}{16}$ SAE FLT
18..	585 52 36-04.....	1	SUPPORT, CONSOLE LT	36..	819 14 16-14.....	2	WASHER $\frac{3}{8}$ STD FLT

ENGINE PLATE

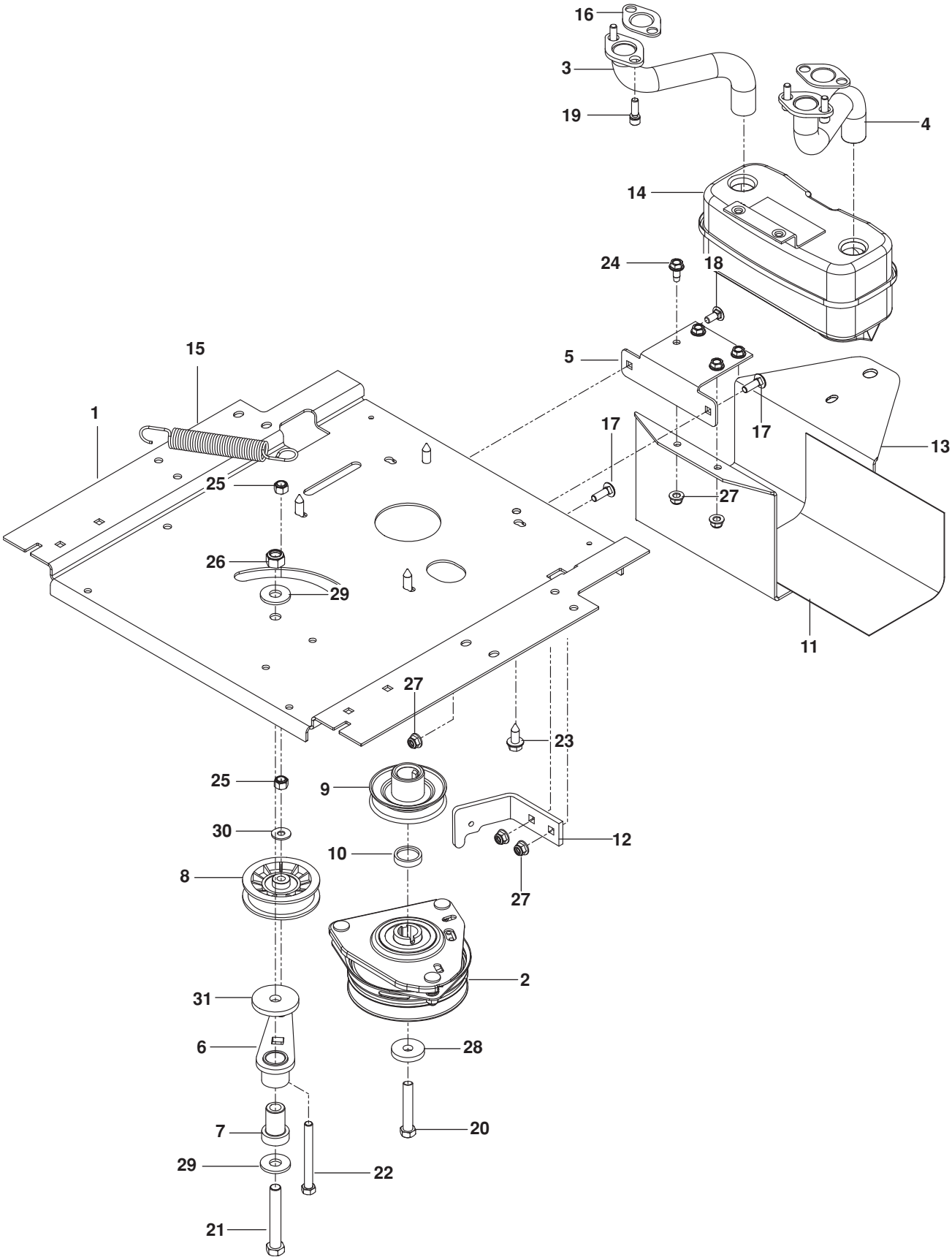

ENGINE PLATE

ITEM	PART NO.	QTY.	DESCRIPTION	ITEM	PART NO.	QTY.	DESCRIPTION
1..	532 44 81-61.....	1	PLATE, ENGINE BLK	18..	872 14 05-06.....	1	BOLT $\frac{5}{16}$ -18 x $\frac{3}{4}$ RD HD SQNK
2..	532 40 00-08.....	1	CLUTCH	19..	532 18 39-06.....	4	SCREW, SCKT HD
3..	581 88 11-01.....	1	TUBE, EXHAUST RT	20..	581 33 28-03.....	1	BOLT $\frac{7}{16}$ -20 x $2\frac{1}{2}$
4..	581 88 10-01.....	1	TUBE, EXHAUST LT	21..	874 78 08-52.....	1	BOLT $\frac{1}{2}$ -13 x $3\frac{1}{4}$
5..	581 88 67-02.....	1	BRACKET, MUFFLER BLK	22..	874 52 06-56.....	1	BOLT $\frac{3}{8}$ -16 x $3\frac{1}{2}$
6..	532 44 81-45.....	1	ARM, IDLER	23..	817 12 06-16.....	4	BOLT $\frac{3}{8}$ -16 x 1 HEX FLG HD
7..	539 10 12-31.....	1	SPINDLE, IDLER	24..	817 49 05-12.....	4	BOLT $\frac{5}{16}$ -18 x $\frac{3}{4}$ HEX FLG HD
8..	539 11 03-11.....	1	PULLEY, IDLER	25..	539 97 69-79.....	2	NUT $\frac{3}{8}$ -16 HEX NYLOC
9..	539 11 45-30.....	1	PULLEY, ENGINE	26..	873 80 08-00.....	1	NUT $\frac{1}{2}$ -13 HEX NYLOC
10..	577 09 46-01.....	1	SPACER	27..	539 11 28-99.....	5	NUT $\frac{5}{16}$ -18 HEX FLG NYLOC
11..	539 13 28-59.....	1	SHIELD, HEAT	28..	532 12 61-97.....	1	WASHER, CLUTCH
12..	522 44 25-06.....	1	STOP, CLUTCH BLK	29..	819 18 22-12.....	2	WASHER $\frac{1}{2}$ FLT
13..	584 98 98-02.....	1	GUARD, MUFFLER BLK	30..	819 12 14-14.....	2	WASHER $\frac{5}{16}$ STD FLT
14..	539 13 16-04.....	1	ASSY, MUFFLER	31..	539 11 26-70.....	1	WASHER, HEAVY
15..	532 19 61-05.....	1	SPRING, DECK DRIVE	NOT SHOWN			
16..	532 16 53-91.....	2	GASKET, MUFFLER		532 19 83-16	1	ADAPTER, CLUTCH
17..	872 14 05-08.....	2	BOLT $\frac{5}{16}$ -18 x 1 RD HD SQNK				

STEERING

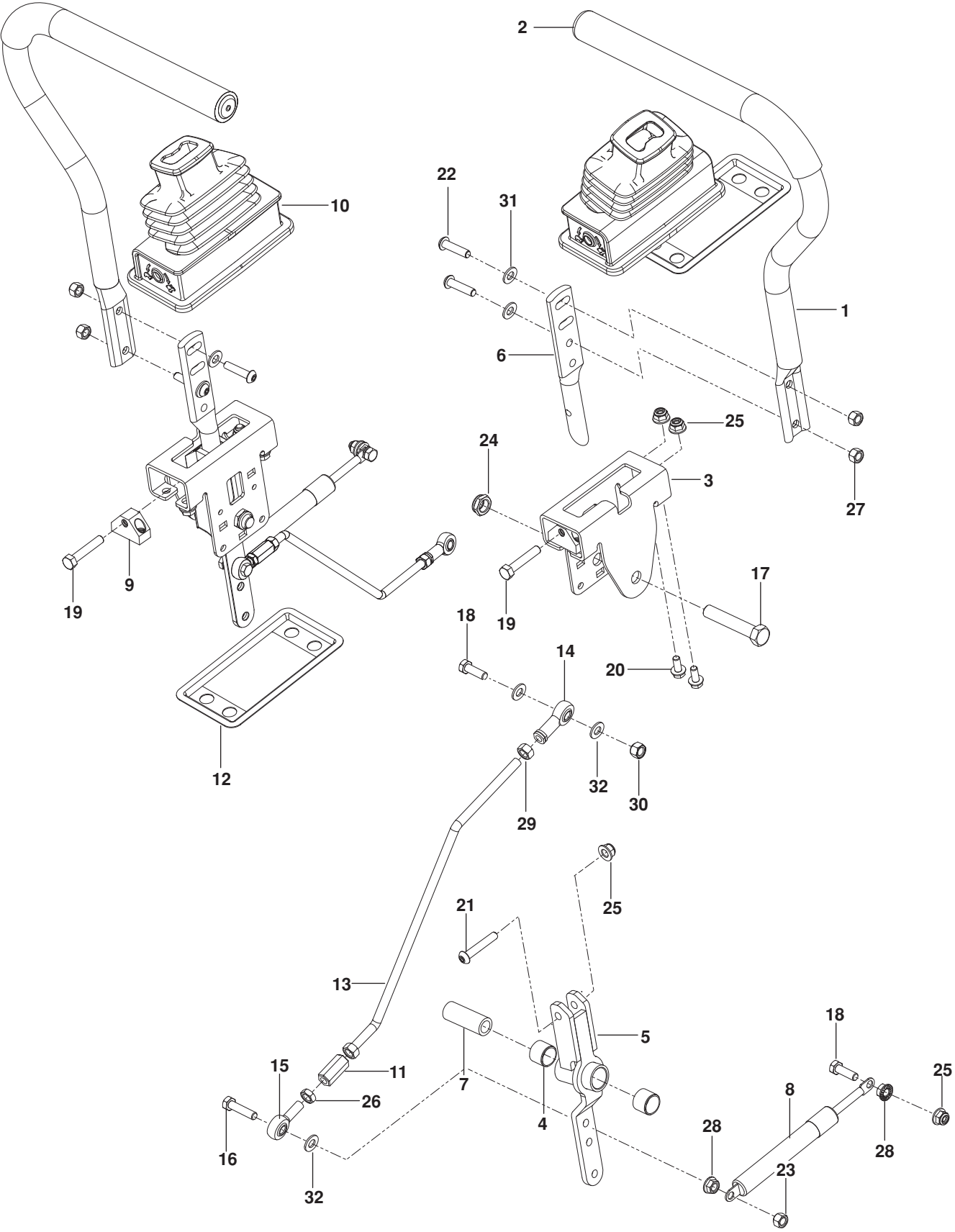

STEERING

ITEM	PART NO.	QTY.	DESCRIPTION	ITEM	PART NO.	QTY.	DESCRIPTION
1..	581 82 67-01.....	2.....	LEVER w/ GRIP	17..	874 78 08-44.....	2.....	BOLT 1/2-13 x 2 3/4
2..	525 39 29-01.....	2.....	GRIP, FOAM	18..	874 78 05-16.....	4.....	BOLT 5/16-18 x 1 THD FRM
3..	585 12 47-02.....	2.....	BRACKET, CONTROL	19..	585 98 61-01.....	2.....	BOLT 5/16-18 x 1 1/4
4..	532 43 82-82.....	4.....	BEARING	20..	874 49 05-12.....	8.....	BOLT 5/16-18 X 3/4 HEX HD FLG
5..	586 02 92-02.....	2.....	LEVER, CONTROL	21..	576 85 04-02.....	2.....	SCREW 5/16-18 X 1 3/4 BTN HD
6..	577 42 00-01.....	2.....	LEVER, HANDLE	22..	585 98 59-01.....	4.....	SCREW 5/16-18 X 1 1/4 BTN BLK
7..	584 92 72-01.....	2.....	SPACER, PIVOT CONTROL	23..	873 80 05-00.....	2.....	NUT 5/16-18 HEX NYLOC
8..	539 10 27-20.....	2.....	DAMPENER	24..	539 10 80-10.....	2.....	NUT 1/2-13 HEX JAM NYL GR2
9..	581 43 75-01.....	2.....	BLOCK, TRACKING	25..	539 11 28-99.....	12.....	NUT 5/16-18 HEX FLG NYLOC
10..	585 83 16-01.....	2.....	BOOT, STEERING	26..	873 70 05-00.....	2.....	NUT 5/16-24 HEX JAM LH
11..	539 11 66-89.....	2.....	COUPLER, ROD END	27..	585 98 60-01.....	4.....	NUT 5/16-18 HEX NYLOC BLK
12..	585 48 82-02.....	2.....	FLANGE, BOOT	28..	539 99 05-85.....	4.....	NUT 5/16-18 HEX WHIZLK
13..	580 62 42-01.....	2.....	ROD, MOTION CONTROL	29..	539 99 02-23.....	4.....	NUT 5/16-24 HEX
14..	539 11 57-29.....	2.....	ROD END RH	30..	539 11 56-17.....	2.....	NUT 5/16-18 THIN NYLOC
15..	539 11 66-90.....	2.....	ROD END MALE LH	31..	586 30 91-01.....	4.....	WASHER 5/16 SAE FLT BLK
16..	874 78 05-28.....	2.....	BOLT 5/16-18 x 1 1/4 TPBLT	32..	819 11 11-16.....	6.....	WASHER 5/16 SAE FLT

IGNITION

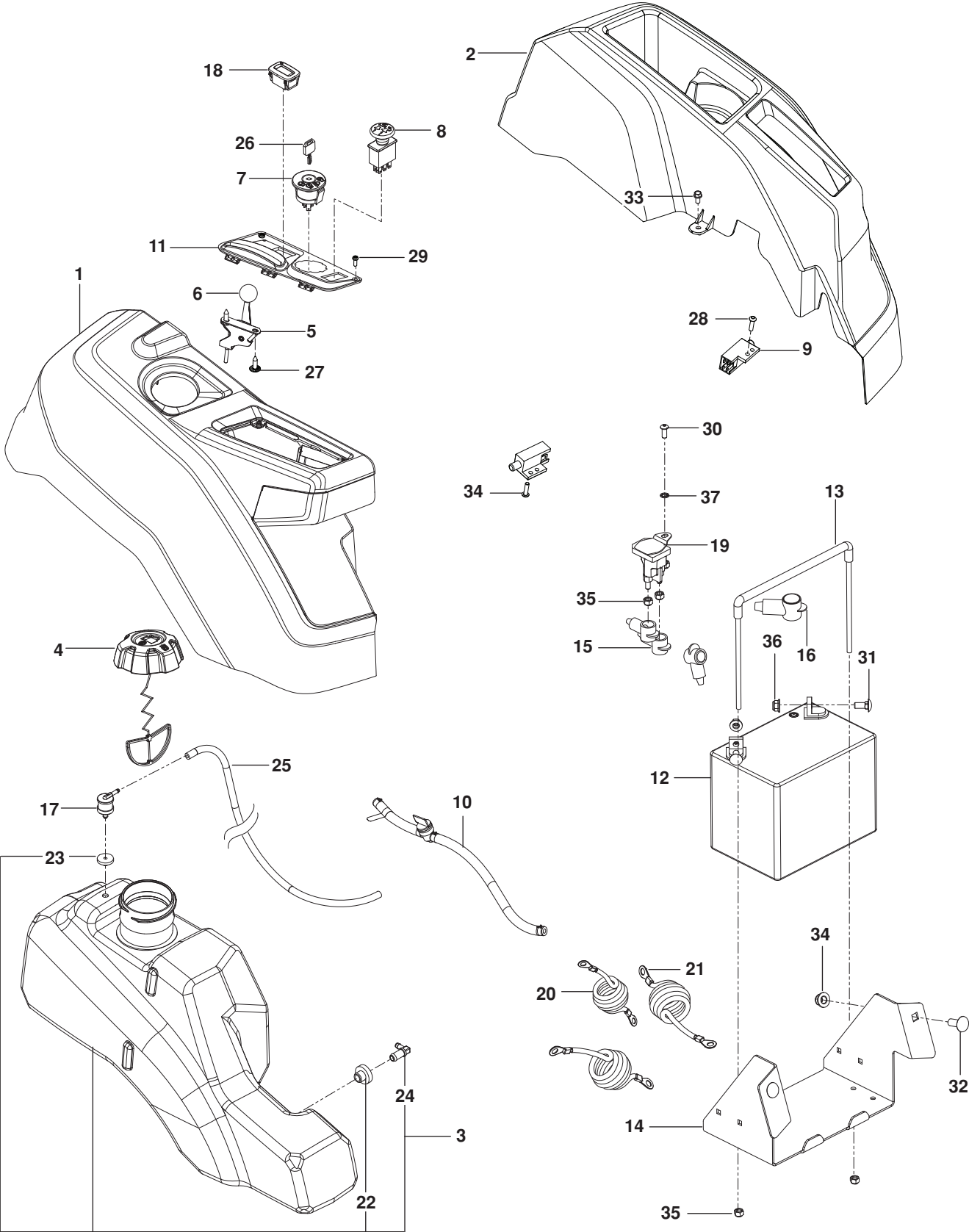

IGNITION

ITEM	PART NO.	QTY.	DESCRIPTION	ITEM	PART NO.	QTY.	DESCRIPTION
1..	585 52 28-01.....	1	ASSY, FENDER, RT GRY	21..	539 10 33-06.....	2	CABLE, POSITIVE RED
2..	585 52 29-01.....	1	FENDER, LT GRY	22..	532 00 36-45.....	1	GROMMET, RUBBER
3..	578 18 06-02.....	1	ASSY, FUEL TANK	23..	532 43 74-92.....	1	GROMMET, CHECK VALVE
4..	585 12 48-01.....	1	CAP, FUEL w/ TETHER	24..	532 13 92-77.....	1	ELBOW
5..	585 97 49-02.....	1	CONTROL, THROTTLE	25..	587 04 45-23.....	1	HOSE $\frac{3}{16}$ x 23" PURGE
6..	539 13 30-49.....	1	KNOB	26..	532 14 04-01.....	1	KEY, IGNITION
7..	539 10 75-41.....	1	SWITCH, IGNITION	27..	532 14 18-41.....	2	SCREW 10-16 x .65
8..	532 17 46-52.....	1	SWITCH, CLUTCH	28..	586 93 60-01.....	2	SCREW #10-24 x $\frac{1}{2}$ SKT HD
9..	532 10 95-53.....	2	SWITCH, INTERLOCK	29..	545 22 71-01.....	2	SCREW 6-19 x $\frac{7}{16}$ PAN HD
10..	586 12 39-04.....	1	ASSY, FUEL LINE w/ VALVE	30..	539 11 12-29.....	1	SCREW $\frac{1}{4}$ -20 x $\frac{5}{8}$ BTN SKT
11..	585 52 27-03.....	1	PANEL, CONTROL	31..	872 14 05-06.....	2	BOLT $\frac{5}{16}$ -18 x $\frac{3}{4}$ RD HD SQNK
12..	539 10 24-36.....	1	BATTERY	32..	539 99 06-45.....	2	BOLT $\frac{3}{8}$ -16 x 1 RD HD SQNK
13..	539 13 12-09.....	1	TIE DOWN, BATTERY	33..	817 49 04-08.....	2	BOLT $\frac{1}{4}$ -20 x $\frac{1}{2}$
14..	585 04 87-02.....	1	BOX, BATTERY BLK	34..	521 99 65-01.....	2	NUT $\frac{3}{8}$ -16 HEX FLG NYLOC
15..	532 13 15-63.....	3	COVER, TERMINAL	35..	873 80 04-00.....	5	NUT $\frac{1}{4}$ -20 HEX NYLOC
16..	539 10 27-59.....	1	INSULATOR	36..	539 11 28-99.....	2	NUT $\frac{5}{16}$ -18 HEX FLG NYLOC
17..	576 61 81-01.....	1	VALVE, FUEL CHECK	37..	539 99 00-53.....	1	WASHER $\frac{1}{4}$ ITLW
18..	586 16 18-01.....	1	METER, SERVICE	NOT SHOWN			
19..	532 19 25-07.....	1	SOLENOID		586 33 73-01	1	HARNES, WIRING
20..	539 11 00-68.....	1	CABLE, NEGATIVE BLK				

BRAKE / LIFT

ITEM	PART NO.	QTY.	DESCRIPTION	ITEM	PART NO.	QTY.	DESCRIPTION
1..	586 42 97-02.....	1	SHAFT, LIFT	14..	532 17 59-94.....	2	NUT, LIFT LINK
2..	586 45 71-01.....	1	LINK, BRAKE LT	15..	510 18 49-01.....	4	NUT, PLASTIC
3..	586 45 72-01.....	1	LINK, BRAKE RT	16..	585 68 21-01.....	2	BRACKET, BELLCRANK
4..	586 42 87-01.....	1	HANDLE, LIFT	17..	586 45 74-01.....	1	BELLCRANK LT
5..	525 84 72-01.....	2	LINK, REAR SUSPENSION	18..	586 45 75-01.....	1	BELLCRANK RT
6..	532 19 51-85.....	2	ARM, SUSPENSION RR	19..	585 68 20-01.....	2	PUSHROD
7..	522 85 86-01.....	2	BRACKET, CENTERING LNK	20..	580 48 61-01.....	2	SPACER
8..	532 44 50-60.....	1	GRIP, HANDLE	21..	585 70 14-01.....	2	PIN 1/2 CLEVIS
9..	586 86 76-01.....	1	SPRING	22..	532 19 85-76.....	2	HAIRPIN
10..	532 19 63-14.....	1	SPRING	23..	812 00 00-02.....	1	E-RING
11..	539 11 87-62.....	2	SPRING	24..	532 13 77-29.....	2	SCREW 1/4-20 x 5/8 THD ROLL
12..	532 19 42-08.....	4	CLIP	25..	586 56 13-01.....	2	SCREW 1/4-20 x 2 1/4 THD ROLL
13..	532 19 42-09.....	1	CLIP				

HYDRAULIC PUMP - MOTOR

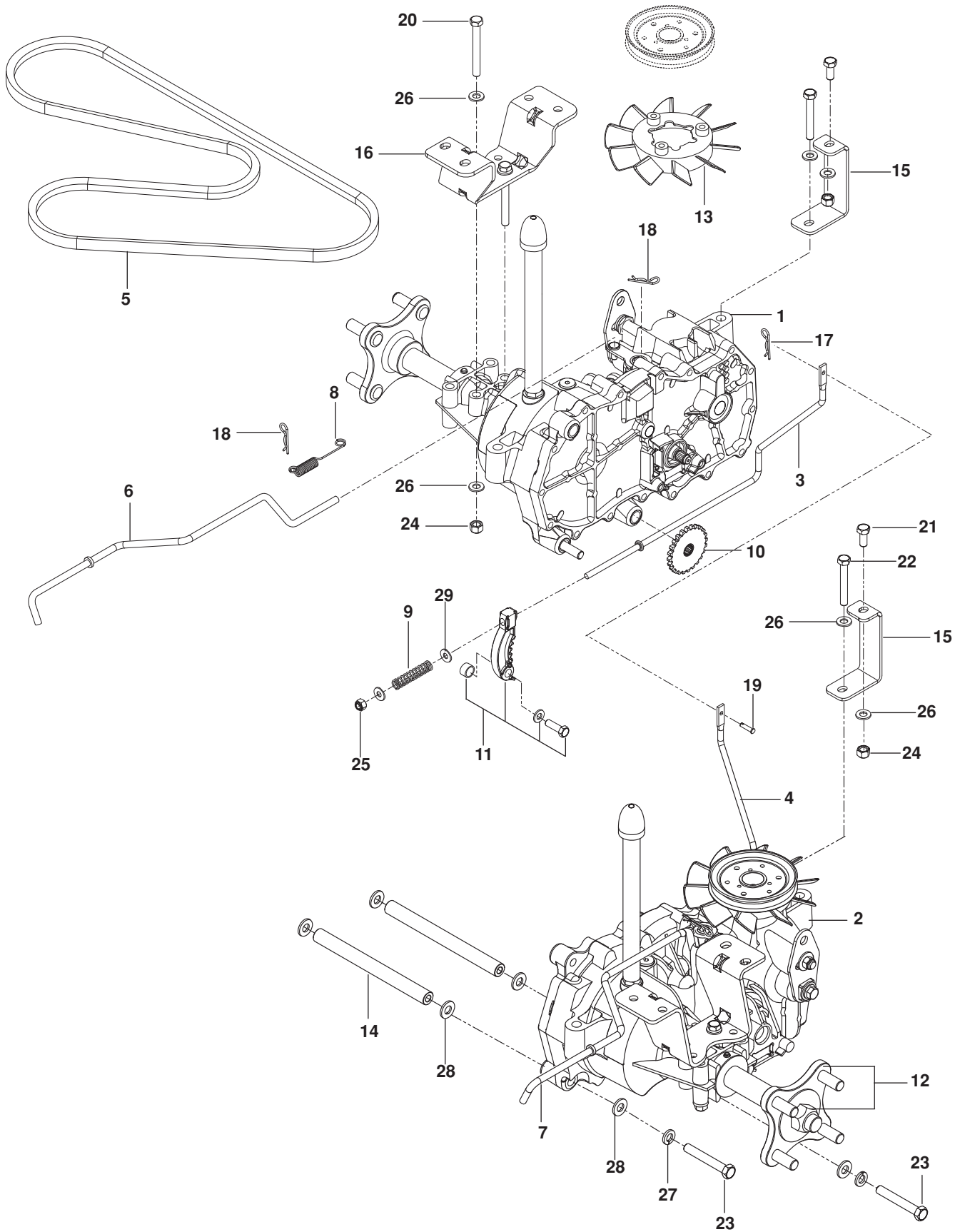

HYDRAULIC PUMP-MOTOR

ITEM	PART NO.	QTY.	DESCRIPTION	ITEM	PART NO.	QTY.	DESCRIPTION
1..	510 37 56-01.....	1	EZT, LT	16..	580 80 66-02.....	2	MOUNT, EZT RR BLK
2..	510 37 56-02.....	1	EZT, RT	17..	532 42 33-03.....	1	HAIRPIN
3..	574 03 05-01.....	1	ROD, EZT BRAKE LT	18..	539 97 69-88.....	4	HAIRPIN
4..	574 03 05-02.....	1	ROD, EZT BRAKE RT	19..	587 11 53-01.....	1	PIN, CLEVIS
5..	539 11 04-11.....	1	BELT, EZT	20..	874 78 05-44.....	4	BOLT ⁵ / ₁₆ -18 x 2 ³ / ₄
6..	585 47 44-01.....	1	ROD, BYPASS LT	21..	874 78 05-12.....	2	BOLT ⁵ / ₁₆ -18 x ³ / ₄
7..	585 47 45-01.....	1	ROD, BYPASS RT	22..	874 78 05-36.....	2	BOLT ⁵ / ₁₆ -18 x 2 ¹ / ₄
8..	586 66 51-01.....	2	SPRING, BYPASS	23..	874 78 06-40.....	4	BOLT ³ / ₈ -16 x 2 ¹ / ₂
9..	539 11 03-42.....	2	SPRING, BRAKE ROD	24..	873 80 05-00.....	8	NUT ⁵ / ₁₆ -18 HEX NYLOC
10..	539 12 00-80.....	2	COG, BRAKE DISC	25..	873 80 04-00.....	2	NUT ¹ / ₄ -20 HEX NYLOC
11..	539 12 00-79.....	2	ASSY, BRAKE ARM	26..	819 11 11-16.....	14	WASHER ⁵ / ₁₆ SAE FLT
12..	575 50 70-01.....	1	ASSY, HUB w/ NUTS	27..	810 03 06-00.....	4	WASHER ³ / ₈ SPLT LCK
13..	539 12 07-85.....	2	BLADE, FAN	28..	819 13 13-16.....	8	WASHER ³ / ₈ SAE FLT
14..	510 18 41-04.....	2	SPACER TUBE	29..	819 09 10-16.....	4	WASHER ¹ / ₄ SAE FLT
15..	580 80 65-02.....	2	SUPPORT, EZT FRT				

WHEELS AND TIRES

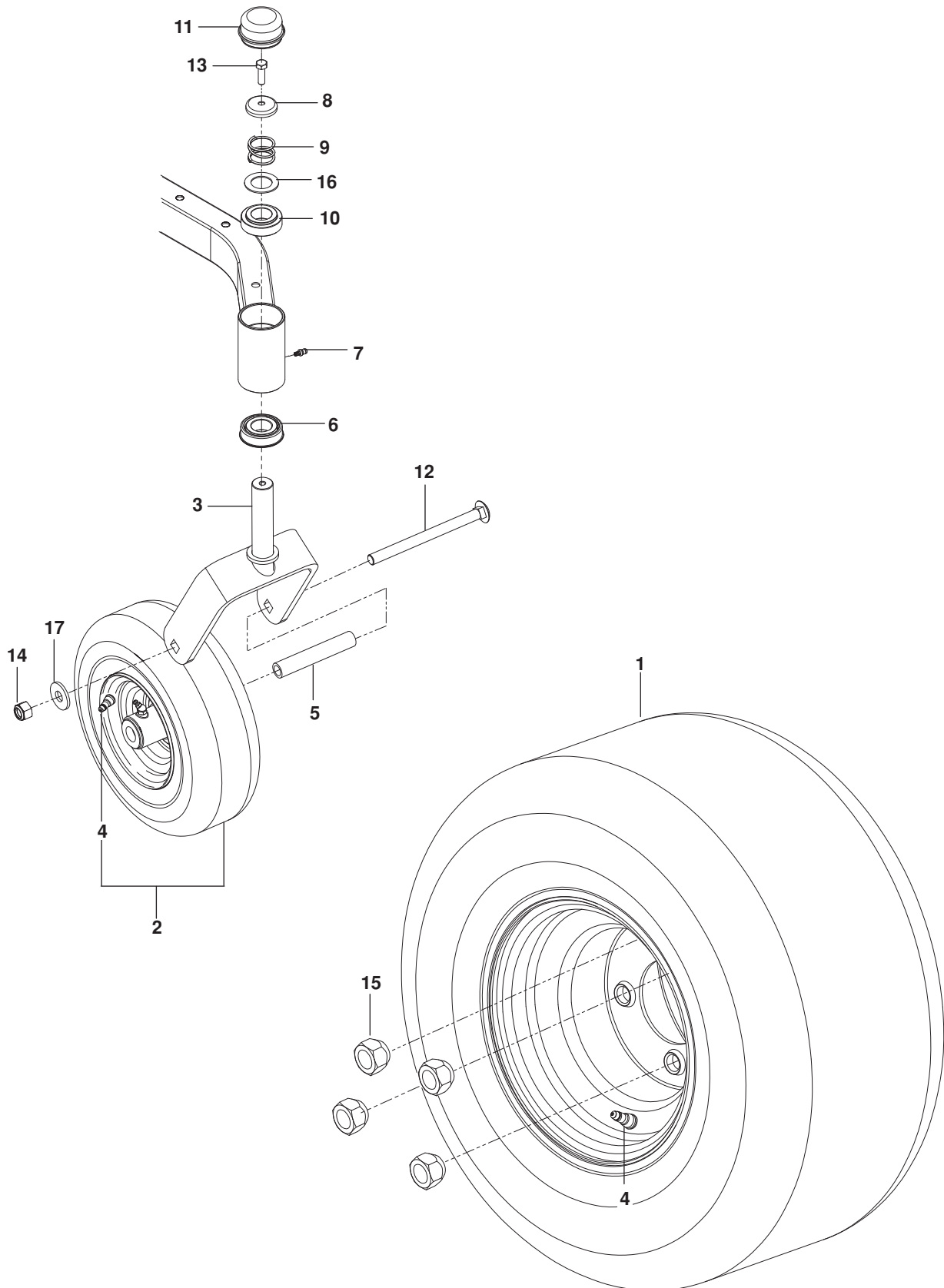

WHEELS AND TIRES

ITEM	PART NO.	QTY.	DESCRIPTION	ITEM	PART NO.	QTY.	DESCRIPTION
1..	579 75 34-01.....	2.....	ASSY, WHEEL REAR 18 x 9.5	10..	539 11 79-01.....	2.....	BUSHING, CASTER
2..	576 58 86-02.....	2.....	ASSY, CASTER TIRE	11..	539 10 25-35.....	1.....	CAP, GREASE
3..	576 58 88-02.....	2.....	YOKE, ORG	12..	576 60 15-01.....	2.....	BOLT 1/2-13 x 7 1/2 RD HD SQNK
4..	539 91 22-34.....	4.....	VALVE STEM	13..	874 95 05-16.....	2.....	BOLT 5/16-18 x 1 w/ NYLON
5..	576 58 89-01.....	2.....	SPACER	14..	873 93 08-00.....	2.....	NUT 1/2 HEX CNTRLK
6..	539 11 26-60.....	2.....	BEARING, FLANGED	15..	539 10 11-73.....	8.....	NUT 1/2 LUG
7..	539 11 56-38.....	2.....	ZERK 3/16 DRIVE	16..	539 11 56-75.....	2.....	WASHER
8..	539 11 57-49.....	2.....	PLUG, CASTER	17..	819 18 22-12.....	2.....	WASHER 1/2 FLT
9..	539 11 57-47.....	2.....	SPRING, CASTER				

MOWER DECK / CUTTING DECK

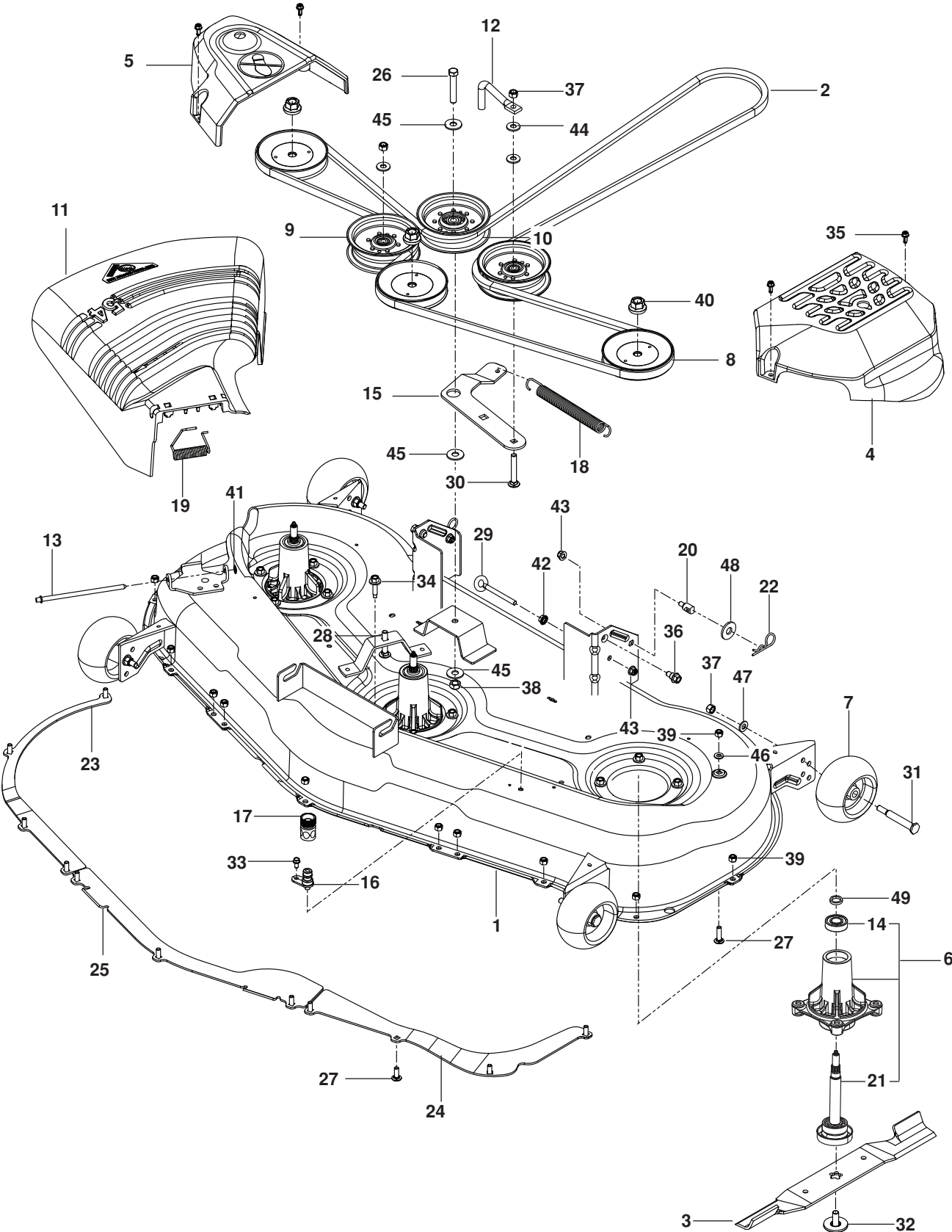

MOWER DECK / CUTTING DECK

ITEM	PART NO.	QTY.	DESCRIPTION	ITEM	PART NO.	QTY.	DESCRIPTION
1..	583 90 93-01.....	1	DECK w/ SAFETY DECALS	26..	539 10 48-70.....	1	BOLT $\frac{7}{16}$ -14 x $2\frac{1}{2}$
2..	539 11 45-57.....	1	V-BELT	27..	539 99 03-16.....	12	RHSNB $\frac{5}{16}$ -18 x $\frac{3}{4}$
3..	532 18 72-56.....	3	BLADE, BAGGING	28..	539 10 01-45.....	1	RHSNB $\frac{3}{8}$ -16 x 2
4..	532 18 72-97.....	1	BELT SHIELD, LT	29..	539 11 55-74.....	1	EYE BOLT $\frac{5}{16}$ x $3\frac{1}{2}$
5..	532 18 81-87.....	1	BELT SHIELD, RT	30..	539 12 81-01.....	1	BOLT $\frac{3}{8}$ -16 x $2\frac{1}{4}$ CARRIAGE
6..	532 18 72-92.....	3	ASSY, MANDREL	31..	539 10 76-08.....	4	BOLT $\frac{1}{2}$ x $2\frac{5}{8}$ SHOULDER
7..	532 17 48-73.....	4	WHEEL, GAUGE	32..	539 10 75-22.....	3	BOLT WASHER ASSM
8..	532 17 34-36.....	3	PULLEY, MANDREL	33..	539 10 84-61.....	1	BOLT $\frac{1}{4}$ -20 x $\frac{1}{2}$ HWST
9..	532 19 61-06.....	2	PULLEY, IDLER	34..	539 10 76-30.....	12	SCREW $\frac{5}{16}$ -18 x WSHR HD
10..	532 19 61-04.....	1	PULLEY, IDLER	35..	539 10 76-31.....	4	SCREW $\frac{1}{4}$ -20 x $\frac{5}{8}$ THDROLL
11..	532 18 72-57.....	1	DEFLECTOR	36..	532 19 65-39.....	2	SCREW, SHOULDER
12..	522 62 97-01.....	1	KEEPER, BELT	37..	539 97 69-79.....	6	NUT $\frac{3}{8}$ -16 HEX NYLOC
13..	532 13 14-91.....	1	ROD, HINGE	38..	539 11 91-24.....	1	NUT $\frac{7}{16}$ -14 HEX NYLOC
14..	532 11 04-85.....	3	BEARING	39..	539 99 07-17.....	12	NUT $\frac{5}{16}$ -18 HEX NYLOC
15..	510 22 00-02.....	1	ARM, IDLER	40..	539 10 75-90.....	3	NUT $\frac{9}{16}$ TOP CNTRLK
16..	532 41 55-98.....	1	PORT, WASHOUT	41..	539 10 76-26.....	1	PUSHNUT
17..	532 41 64-05.....	1	COUPLING, QUICK CONN	42..	539 99 05-85.....	1	NUT $\frac{5}{16}$ -18 HEX WHIZLK
18..	539 12 09-20.....	1	SPRING, DECK BELT	43..	539 11 28-99.....	4	NUT $\frac{5}{16}$ -18 HEX FLG NYLOC
19..	539 10 76-09.....	1	SPRING, TORSION	44..	539 99 05-17.....	3	WASHER $\frac{3}{8}$ FLT STD
20..	532 19 51-61.....	2	STUD, w/ ANTI-ROTATE	45..	539 10 48-64.....	3	WASHER $\frac{7}{16}$ FLT
21..	532 18 72-91.....	1	SHAFT	46..	539 99 01-88.....	1	WASHER $\frac{5}{16}$ SAE FLT
22..	539 97 69-89.....	2	HAIRPIN #4	47..	539 99 01-22.....	4	WASHER $\frac{3}{8}$ SAE FLT
23..	539 11 20-59.....	1	BAFFLE, RT	48..	539 10 95-54.....	2	WASHER $\frac{1}{2}$ FLT
24..	539 11 20-60.....	1	BAFFLE, LT	49..	532 18 76-90.....	3	WASHER/SPACER
25..	539 11 20-62.....	1	BAFFLE, CENTER				

SEAT

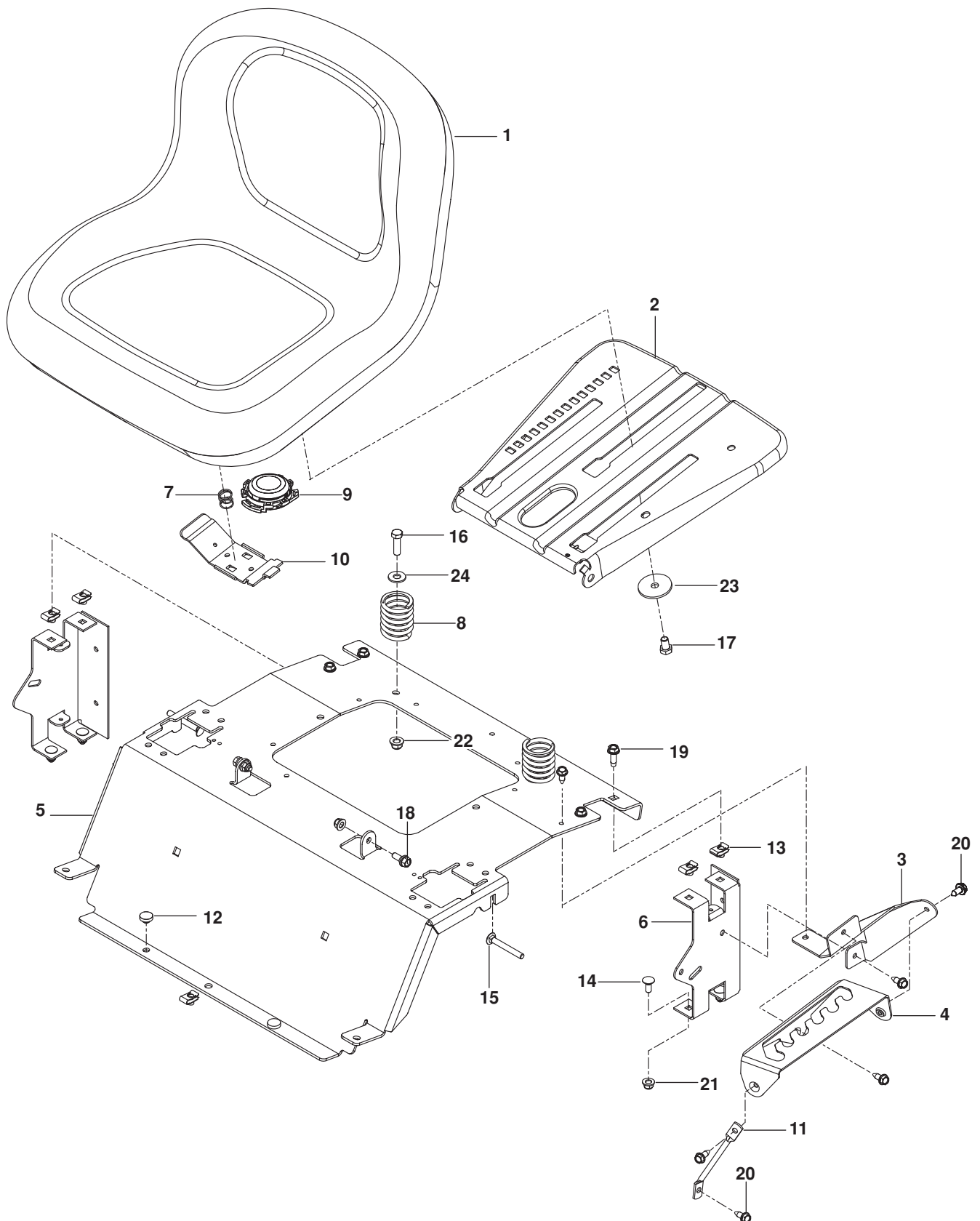

SEAT

ITEM	PART NO.	QTY.	DESCRIPTION	ITEM	PART NO.	QTY.	DESCRIPTION
1..	532 43 98-22.....	1	SEAT	13..	539 10 47-63.....	5	RETAINER, U TYPE
2..	532 19 69-77.....	1	PAN, SEAT	14..	872 14 05-06.....	4	BOLT ⁵ / ₁₆ -18 x ³ / ₄ RD HD SQNK
3..	586 22 08-02.....	1	PLATE, LIFT SUPPORT	15..	510 42 27-01.....	2	BOLT ⁵ / ₁₆ -18 x 2 ¹ / ₂ RD HD SQNK
4..	586 22 12-02.....	1	PLATE, DECK LIFT	16..	874 78 06-20.....	2	BOLT ³ / ₈ -16 x 1 ¹ / ₄
5..	577 26 05-03.....	1	SUPPORT, SEAT ORG	17..	874 78 06-10.....	1	BOLT ³ / ₈ -16 x ⁵ / ₈
6..	580 30 82-02.....	2	SUPPORT, SEAT RR BLK	18..	539 11 03-03.....	2	BOLT ⁵ / ₁₆ -18 SHOULDER
7..	532 19 82-00.....	1	SPRING, LATCH	19..	817 49 05-12.....	4	BOLT ⁵ / ₁₆ -18 X ³ / ₄ HEX HD FLG
8..	532 12 41-81.....	2	SPRING, SEAT	20..	817 00 05-10.....	6	SCREW ⁵ / ₁₆ -18 x ⁵ / ₈ WSH HD
9..	532 40 15-45.....	1	SWITCH, SEAT	21..	539 11 28-99.....	4	NUT ⁵ / ₁₆ -18 HEX FLG NYLOC
10..	532 19 76-61.....	1	HANDLE, SLIDE	22..	521 99 65-01.....	2	NUT ³ / ₈ -16 HEX FLG NYLOC
11..	586 42 86-01.....	1	LEG, SUPPORT	23..	539 11 18-97.....	1	WASHER ³ / ₈ SPECIAL
12..	585 98 93-01.....	2	GROMMET, BUMPER	24..	819 14 16-14.....	2	WASHER ³ / ₈ STD FLT

DECALS

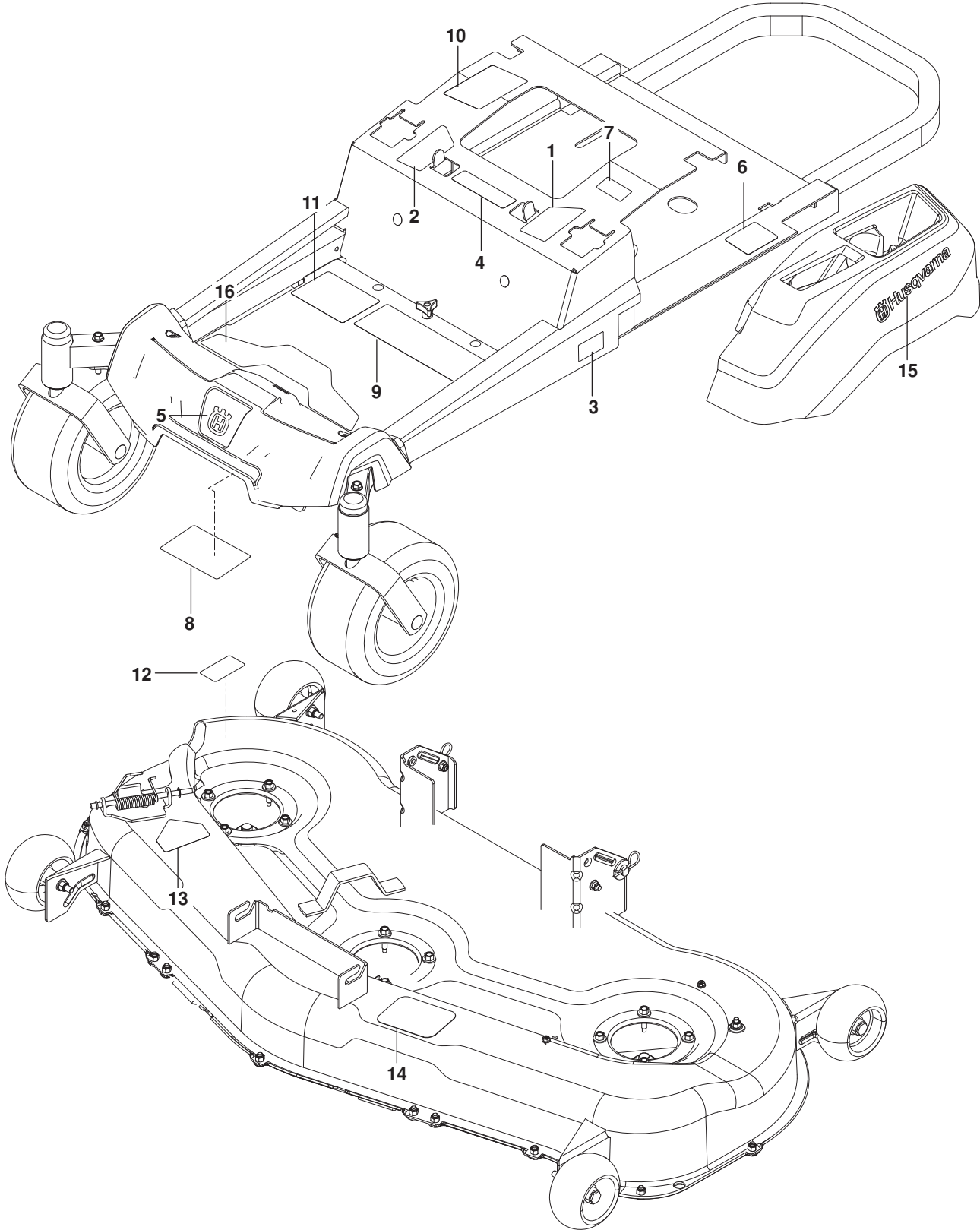

DECALS

ITEM	PART NO.	QTY.	DESCRIPTION	ITEM	PART NO.	QTY.	DESCRIPTION
1..	586 94 76-01.....	1	DECAL, STEER / BRAKE LT	9..	539 10 99-08.....	1	DECAL, SAFETY WARNINGS
2..	586 94 75-01.....	1	DECAL, STEER / BRAKE RT	10..	532 42 38-29.....	1	DECAL, RESPONSIBILITY
3..	587 22 01-01.....	2	DECAL, Z 254	11..	586 25 84-01.....	1	DECAL, START
4..	539 10 57-45.....	1	DECAL, BATTERY WARNING	12..	581 72 44-01.....	1	DECAL, DEFLECTOR
5..	532 42 86-77.....	1	DECAL, CROWN	13..	584 90 46-01.....	1	DECAL, BLADE DANGER
6..	539 10 83-85.....	1	DECAL, DO NOT TOW	14..	539 11 26-20.....	1	DECAL, BELT ROUTING
7..	539 10 83-86.....	1	DECAL, EXIT MOWER	15..	577 46 90-01.....	2	DECAL, HUSQVARNA
8..	539 10 98-97.....	1	DECAL, SERVICE	16..	587 00 07-01.....	1	PAD, ABRASIVE

