

115 78 90-27 Rev. 2



# Repair Parts Manual Manual De Repuestos

GT52XLS / 96043015903

Please read the operator's manual carefully and make sure you understand the instructions before using the machine.

Por favor lea cuidadosamente y comprenda estas intrucciones antes de usar esta maquina.



English/Spanish

# HOW TO USE THIS MANUAL

This manual is designed to provide the customer with a means to identify the parts on his/her tractor when ordering repair parts. The illustrations may or may not represent the actual assemblies; therefore, it is not recommended to use this manual as a guide to assemble or disassemble the tractor. Some hardware and parts are drawn larger in order to more readily identify them.

Each tractor has its own model number.

The model number for your tractor can be found on the fender under the seat.

When ordering parts, always give the following information:

- Product - "TRACTOR"
- MODEL NUMBER - "GT52XLS" (96043015903)"
- Part Number
- Part Description

## TABLE OF CONTENTS

SCHEMATIC .....	3
ELECTRICAL.....	4-5
CHASSIS.....	6-7
DRIVE.....	8-9
ENGINE.....	10-11
STEERING .....	12-13
MOWER DECK.....	14-15
MOWER LIFT.....	16
SEAT .....	17
DECALS.....	18

## COMO UTILIZAR ESTE MANUAL

Este manual está diseñado para brindarle al comprador un medio para identificar las piezas del tractor para cuando necesite hacer el pedido de un repuesto. Las ilustraciones pueden o no representar los ensambles reales; por lo tanto, no se recomienda utilizar este manual como una guía para ensamblar o desarmar el tractor. Algunos accesorios y piezas están dibujados en tamaños más grandes para identificarlos con mayor facilidad.

Cada tractor tiene su propio número de modelo.

El número de modelo del tractor se encuentra en el guardabarros debajo del asiento.

Cuando haga el pedido de una pieza, siempre brinde la siguiente información:

- Producto: "TRACTOR"
- NÚMERO DE MODELO: "GT52XLS"(96043015903)"
- Número de pieza
- Descripción de la pieza

## ÍNDICE

DIAGRAMA.....	19
DIAGRAMA ELÉCTRICO .....	20-21
CHASIS.....	22-23
TRANSMISIÓN .....	24-25
MOTOR.....	26-27
DIRECCIÓN .....	28-29
PLATAFORMA DE LA CORTADORA DE CÉSPED .....	30-31
ELEVACIÓN DE LA CORTADORA DE CÉSPED.....	32
ASIENTO.....	33
CALCOMANÍAS.....	34

# TRACTOR - MODEL NO. GT52XLS (96043015903), PRODUCT NO. 960 43 01-59 SCHEMATIC

SCH12

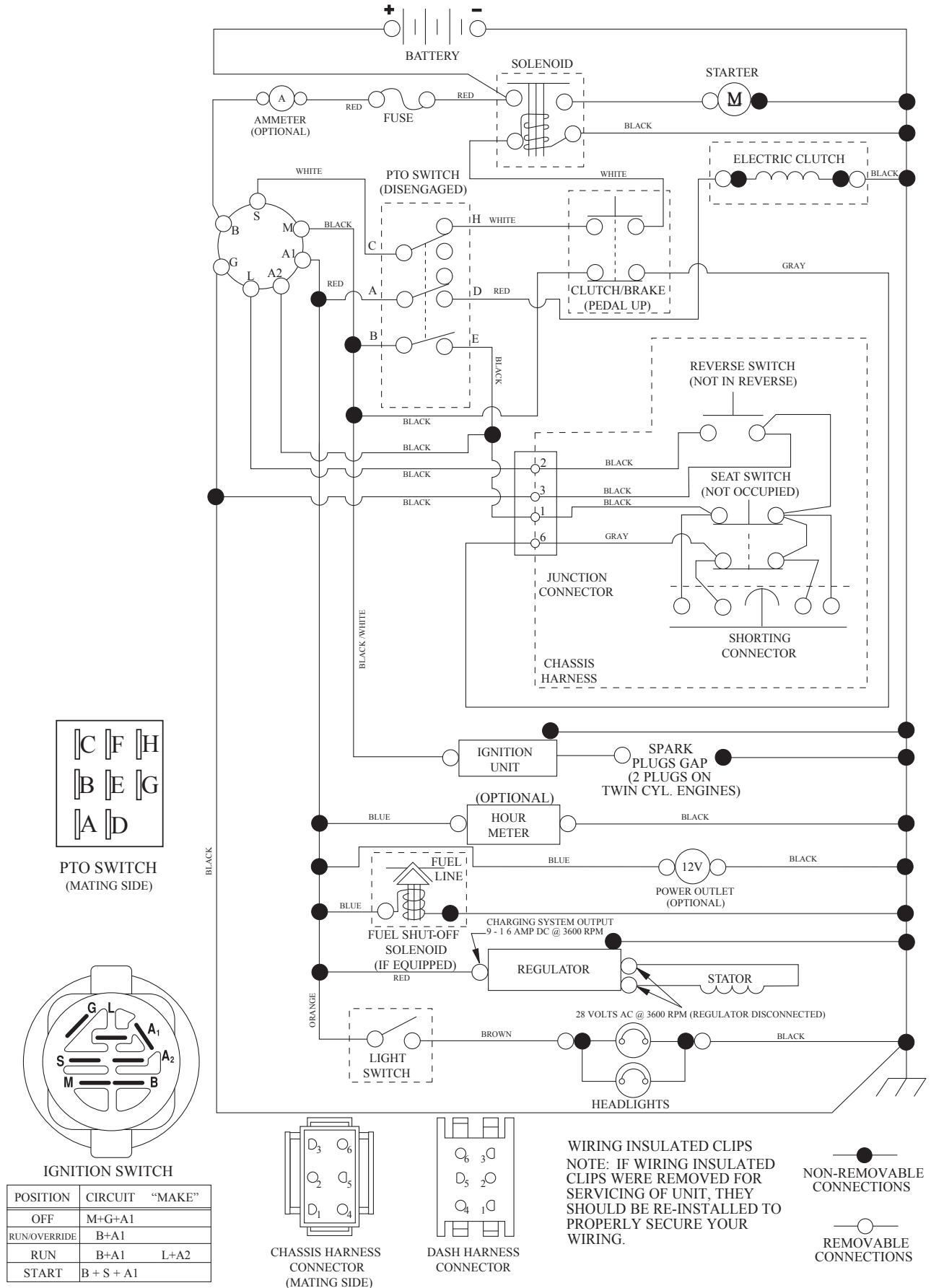



**TRACTOR - MODEL NO. GT52XLS (96043015903), PRODUCT NO. 960 43 01-59  
ELECTRICAL**

<b>KEY NO.</b>	<b>PART NO.</b>	<b>DESCRIPTION</b>
1	532 16 34-65	Battery
2	874 76 04-12	Bolt Hex Hd 1/4-20 unc x 3/4
8	587 20 51-01	Battery Box
16	532 17 61-38	Switch Interlock
21	532 40 02-52	Harness Socket Light
22	532 00 41-52	Bulb, Light #1156
24	585 55 56-01	Cable Battery
25	585 55 55-01	Cable Starter
26	532 17 51-58	Fuse
27	873 51 04-00	Nut Keps Hex 1/4-20 unc
28	532 41 65-88	Cable Ground 21" Blk 6 Ga.
29	532 40 15-45	Switch Seat
30	532 19 33-50	Switch Ign
33	532 41 19-33	Key/Chain
34	532 11 07-12	Switch Light/Reset
40	501 13 31-01	Harness Ign. Dash
41	817 72 04-08	Screw 1/4-20 unc x 1/2
42	532 13 15-63	Cover Terminal Red
43	532 19 25-07	Solenoid
45	587 55 39-03	Ammeter Round
46	587 55 40-03	Gauge Hourmeter
50	532 17 46-51	Switch PTO
55	817 06 05-12	Screw Thdrol 5/16-18 x 3/4
59	532 40 03-03	Outlet 12-Volt
71	532 19 42-76	Harness Ign Chassis
79	532 17 52-42	Socket Asm. Bulb Twistlock
90	532 43 53-95	Cover Terminal Battery
99	817 67 04-12	Screw Hexwsh Thdrol 1/4-20 x 3/4
100	819 09 14-16	Washer 9/32 x 7/8 x 16 Ga.
103	532 42 17-47	Harness Pigtail 12V Outlet
141	532 42 12-25	Kit G700/G730 ROS
142	583 85 78-01	Harness Charge Port
143	532 44 80-59	Charge Port

**NOTE:** All component dimensions given in U.S. inches  
1 inch = 25.4 mm



**TRACTOR - MODEL NO. GT52XLS (96043015903), PRODUCT NO. 960 43 01-59  
CHASSIS**

KEY NO.	PART NO.	DESCRIPTION
2	580 43 44-01	Drawbar
3	532 44 44-81	Applique Sub Asm.
5	532 43 74-75	Dash
14	532 44 11-77	Hood
15	532 43 97-33	Lens LH
18	532 44 06-53	Grille
25	532 44 33-85	Lens RH
36	817 06 05-12	Screw 5/16-18 x 3/4
37	532 44 12-08	Fender
58	532 19 43-14	Bracket Fender
68	817 49 05-08	Screw 5/16-18 x 1/2
125	581 68 48-01	Clip Fuel Line
130	532 41 63-58	Screw #10 x 0.750 BOS Thread
137	532 40 75-90	Bumper Dash
146	581 85 79-01	Bolt
150	532 43 97-74	Duct Air
151	532 43 66-70	Bracket Pivot Hood
152	532 43 98-70	Shield Browning/Debris
159	817 00 06-12	Screw 3/8-16 x 3/4
161	532 43 99-29	Console Fuel Window
162	532 14 24-32	Screw Hex Wsh Hi-Lo 1/4 x 1/2
165	532 19 43-30	Bracket Support Tank
175	532 19 63-04	Crossmember
176	532 40 07-76	Screw 10-24 x 5/8 Wshd Qdrx
177	532 19 52-28	Bushing Steering
180	532 44 55-59	Chassis
182	532 40 68-59	Dash Lower
183	874 52 05-20	Bolt 5/16-18 x 1-1/4

KEY NO.	PART NO.	DESCRIPTION
189	817 00 05-12	Screw 5/16-18 x 3/4
191	532 43 74-55	Insert Reflective RH
194	873 90 05-00	Nut Lock Hex Flange 5/16-18
196	532 43 96-74	Console Asm. Deck Lift
199	532 19 82-59	Plate Deck Lift
202	532 43 97-28	Vent Side Hood RH
203	532 43 97-27	Vent Side Hood LH
204	532 43 57-14	Vent Asm Hood Top
205	532 43 97-30	Skirt Hood Side RH
206	532 43 97-29	Skirt Hood Side LH
207	532 43 97-34	Bezel RH
208	532 43 97-35	Bezel LH
214	532 19 91-45	Clip Retainer
217	532 40 91-67	Rod Pivot
221	532 19 89-09	Reflector LH
228	532 19 51-61	Stud Fastener
235	532 40 61-29	Spacer Fender
236	873 93 05-00	Nut Center Lock 5/16-18 unc
297	532 43 74-56	Insert Reflective LH
306	873 90 06-00	Nut Lock
335	532 44 82-04	Cover RH
336	532 44 53-09	Cover LH
350	532 44 51-43	Clip X-mas Tree
375	586 90 82-01	Dash Clip-On Bumper
--	532 43 18-82	Kit Guard Brush

**NOTE:** All component dimensions given in U.S. inches  
1 inch = 25.4 mm

**TRACTOR - MODEL NO. GT52XLS (96043015903), PRODUCT NO. 960 43 01-59  
DRIVE**

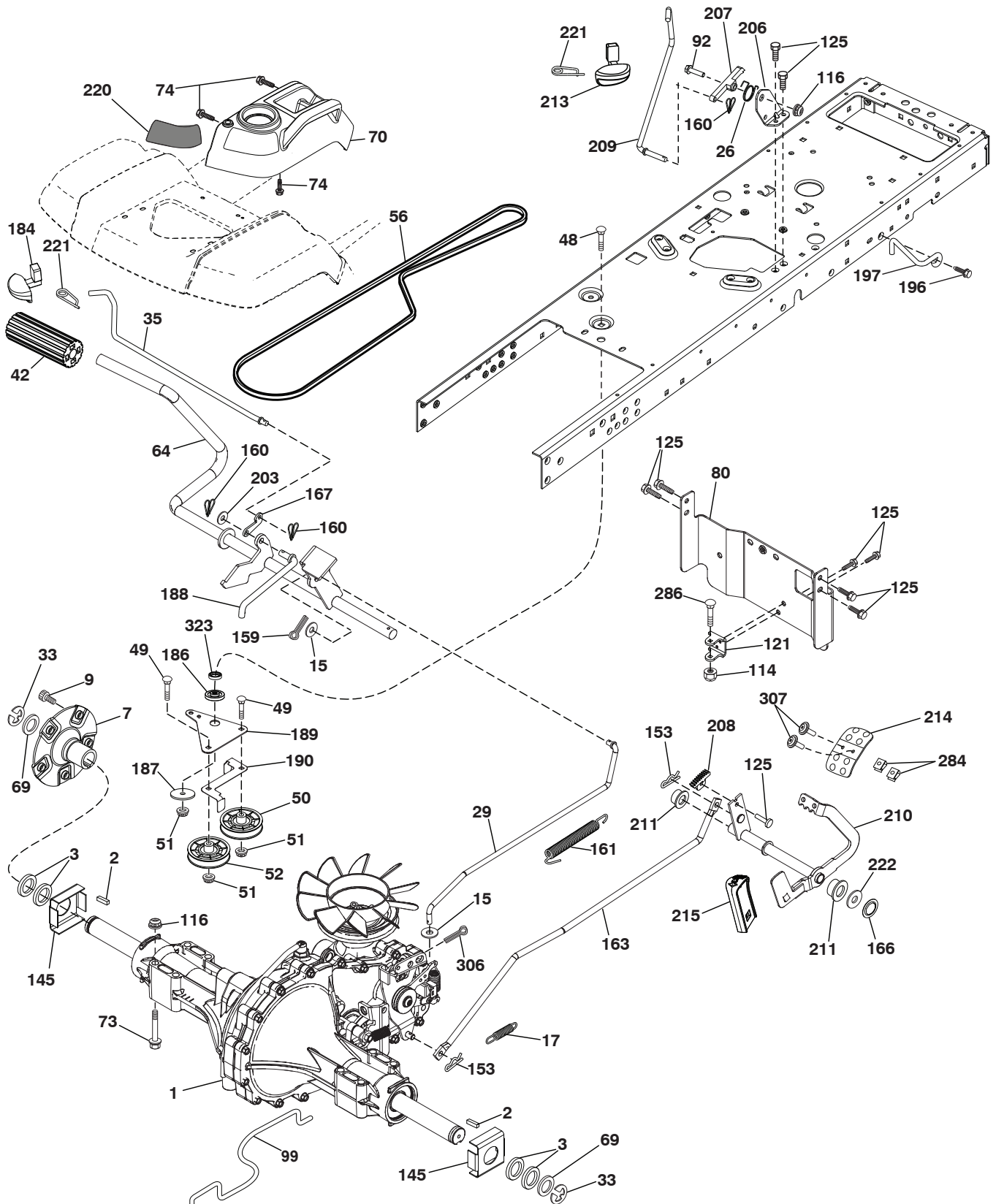

drive-tex\_G730\_pedal\_6\_r2



**TRACTOR - MODEL NO. GT52XLS (96043015903), PRODUCT NO. 960 43 01-59  
DRIVE**

KEY NO.	PART NO.	DESCRIPTION	KEY NO.	PART NO.	DESCRIPTION
1	---	Transaxle, Hydro G7-BCBB-1XDC-1FCA (420331) (Order parts from transaxle manufacturer.)	160	532 16 94-84	Retainer Clip
2	532 00 70-70	Key 1/4 x 2.5	161	532 10 57-09	Spring, Return, Clutch
3	532 00 75-63	Washer Thrust Axle Hardened	163	532 41 81-85	Rod Pedal Control
7	532 19 98-37	Hub Asm. Wheel	166	532 42 91-64	Nut Push .625
9	532 14 00-80	Bolt Hub Wheel	167	532 40 52-57	Latch Brake Parking
15	819 13 13-16	Washer 13/32 x 13/16 x 16 Ga.	184	587 65 37-01	Handle Parking Brake
17	532 19 72-96	Spring, Brake	186	532 19 43-21	Spacer Retainer
26	532 19 96-79	Spring Return Cruise	187	819 13 32-10	Washer
29	532 41 81-86	Rod, Brake	188	532 19 43-23	Link Clutch Ground Drive
33	812 00 00-53	Ring E	189	532 40 75-04	Bellcrank Ground Drive
35	583 86 45-01	Rod, Brake, Park	190	532 40 75-05	Keeper Bellcrank Ground Drive
42	532 12 48-72	Cover, Foot Pedal	196	817 00 06-16	Screw 3/8-16 x 1
48	872 11 06-12	Bolt Carr Sh 3/8-16 x 1-1/2 Gr.5	197	585 65 86-01	Bracket Clutch Anti-Rotation
49	872 11 06-14	Bolt	203	819 11 11-16	Washer 11/32 x 11/16 x 16 Ga.
50	532 19 43-27	Pulley Idler Flat	206	532 44 85-96	Bracket Mount Latch Cruise
51	873 90 06-00	Lock Nut 3/8-16	207	587 03 14-01	Latch Control Cruise
52	532 19 43-26	Idler V-Groove Offset	208	532 19 78-69	Gear Sector Control Cruise
56	532 42 08-07	V-Belt, Drive	209	532 19 95-92	Rod Control Cruise
64	532 19 78-65	Shaft Asm. Pedal Brake Control	210	532 19 78-60	Rocker Asm. Pedal Control
69	532 12 38-00	Washer 1-1/32 x 1-5/8 x 16 Ga.	211	532 12 01-83	Bearing Nylon
70	532 43 96-61	Console Asm	213	532 40 31-19	Knob Control Cruise
73	874 49 05-48	Bolt Hex 5/16-18 x 3 Gr. 5	214	532 41 68-63	Pedal Forward
74	532 14 24-32	Screw 1/4 x 1/2	215	532 40 17-23	Pedal Reverse
80	532 41 81-84	Strap Torque	220	532 19 89-08	Reflector RH
92	874 76 05-20	Bolt 5/16-18 x 1/2	221	532 40 31-87	Retainer Spring Clip Handle
99	532 41 81-88	Spring Bypass	222	879 21 20-10	Washer 21/32 x 1-1/4 x 10 Ga.
114	873 80 05-00	Nut Lock Hex W/Ins. 5/16-18 unc	284	532 41 76-93	Nut U-Chnl. 1/4-20
116	873 90 05-00	Nut Lock Hex Flange 5/16-18	286	872 01 05-20	Bolt 5/16-18 x 2.50
121	532 17 56-11	Bracket Strap Torque	306	876 02 04-16	Pin Cotter 1/8 x1
125	817 00 05-12	Screw 5/16-18 x 3/4	307	874 18 04-12	Screw Mach 1/4-20 x 3/4
145	532 16 31-68	Washer Axle Flange	323	585 71 41-01	Sleeve Bellcrank
153	532 12 47-88	Retainer Spring			
159	876 02 04-12	Pin Cotter 1/8 x 3/4			

**NOTE:** All component dimensions given in U.S. inches  
1 inch = 25.4 mm

**TRACTOR - MODEL NO. GT52XLS (96043015903), PRODUCT NO. 960 43 01-59  
ENGINE**

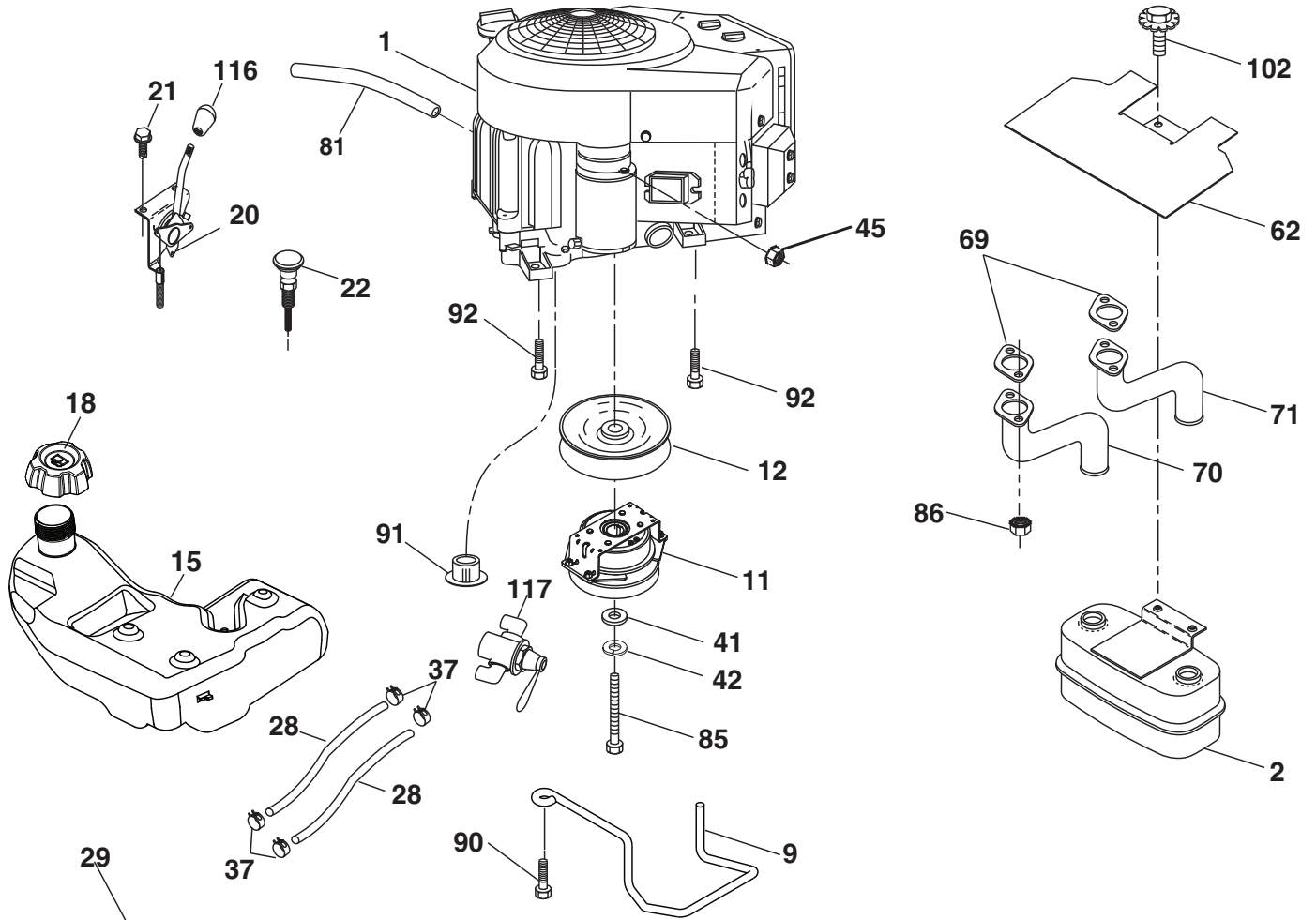

**SPARK ARRESTER KIT**

engine-tex\_Kawa-2cyl\_49\_r1

**TRACTOR - MODEL NO. GT52XLS (96043015903), PRODUCT NO. 960 43 01-59  
ENGINE**

<b>KEY NO.</b>	<b>PART NO.</b>	<b>DESCRIPTION</b>
1	-- -- -- --	Engine KAWA Model No. FR730V-DS04 (445363)(Order parts from engine manufacturer.)
2	532 44 59-62	Muffler
9	532 40 86-67	Keeper Asm. Belt Engine
11	587 24 14-01	Clutch Electric
12	532 19 43-43	Pulley Engine
15	532 43 80-82	Tank Fuel
18	585 12 48-01	Cap Asm
20	532 42 43-41	Control Throttle
21	532 41 63-58	Screw #10 x 0.750 BOS Thread
22	532 19 15-96	Control Choke
28	532 40 11-35	Fuel Line
29	532 13 71-80	Spark Arrester Kit
37	532 12 34-87	Clamp Hose
41	532 12 61-97	Washer 1-1/2 OD x 15/32 ID x .250
42	810 04 07-00	Washer Lock 7/16
45	873 51 04-00	Nut Keps Hex 1/4-20 unc
62	532 43 40-17	Shield Heat Muffler
69	532 17 81-51	Gasket
70	583 95 56-01	Tube Exhaust LH
71	583 95 57-01	Tube Exhaust RH
81	532 14 84-56	Oil Tube Drain
85	581 63 62-01	Bolt 7/16-20 x 3.0 x Gr. 5
86	532 18 43-62	Nut Hex M8-1.25
90	817 00 06-16	Screw 3/8-16 x 1
91	532 18 74-95	Bushing
102	817 00 05-12	Screw 5/16 x 3/4
92	817 12 06-16	Screw 3/8-16 x 1
116	539 13 26-24	Knob Soft Touch
117	532 42 08-28	Valve Fuel Reserve

**NOTE:** All component dimensions given in U.S. inches  
1 inch = 25.4 mm

For engine service and replacement parts, call the toll free number for your engine manufacturer listed below:

Kawasaki 1-949-460-5688

**TRACTOR - MODEL NO. GT52XLS (96043015903), PRODUCT NO. 960 43 01-59**  
**STEERING ASSEMBLY**

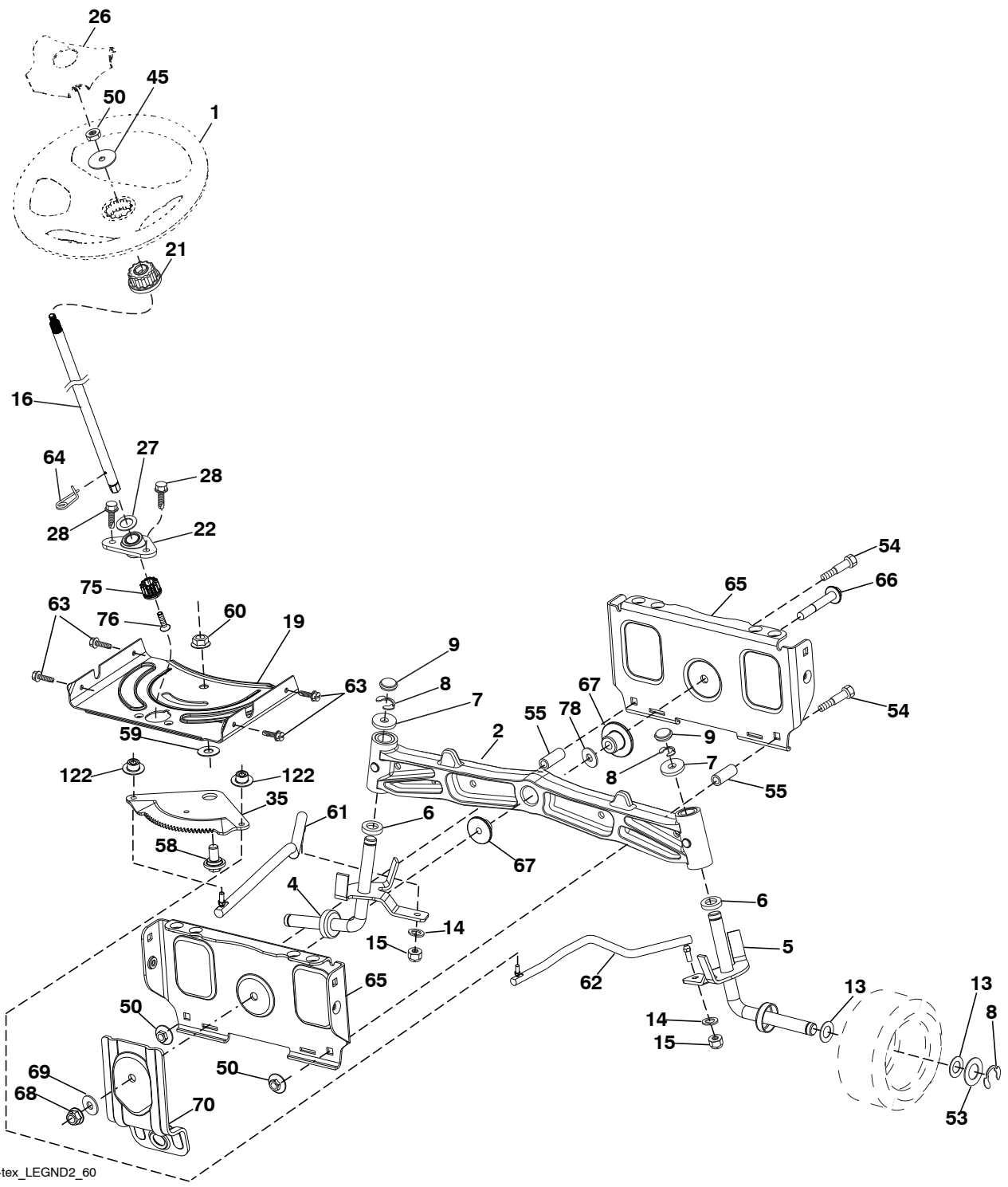

Steering-tex\_LEGND2\_60

**TRACTOR - MODEL NO. GT52XLS (96043015903), PRODUCT NO. 960 43 01-59  
STEERING ASSEMBLY**

<b>KEY PART NO.</b>	<b>PART NO.</b>	<b>DESCRIPTION</b>
1	532 43 97-40	Wheel, Steering
2	532 19 59-68	Axle Asm., Front
4	532 40 30-89	Spindle Asm. LH
5	532 40 30-90	Spindle Asm. RH
6	532 12 49-31	Bearing, Race Thrust Harden
7	532 12 17-48	Washer 25/32 x 1-5/8 x 16 Ga.
8	812 00 00-29	Ring, Clip #T5304-75
9	532 12 12-32	Cap, Spindle
13	532 12 17-49	Washer 25/32 x 1-1/4 x 16 Ga.
14	810 04 06-00	Washer, Lock Hvy Hlcl Spr 3/8
15	873 54 06-00	Nut, Crown Lock 3/8-24 unf
16	587 01 60-02	Steering Shaft
19	532 19 47-29	Plate Steering
21	586 84 02-01	Adapter Wheel Steering
22	585 02 98-02	Bearing
26	532 43 97-43	Insert, Wheel Steering
27	819 21 16-16	Washer
28	817 00 06-12	Screw 3/8-16 x 3/4
35	532 19 47-32	Gear, Sector Plate
45	587 01 64-01	Washer 3/8 ID 2-3/8 OD 12 Ga. PLTD
50	873 90 06-00	Nut Lock Flg 3/8-16 unc
53	532 18 89-67	Washer Hardened .793 x 1.637 x .060
54	874 76 06-36	Bolt Hex 3/8-16 unc x 2-1/4
55	532 41 47-36	Bolt Hex 3/8-16 unc x 2-1/4
58	532 19 47-47	Bolt Shoulder Sector Pivot CFM
59	532 19 47-48	Washer Thrust Sector Steering
60	873 97 10-00	Nut Flange Lock 5/8-11
61	532 19 47-40	Draglink, LH
62	532 19 47-41	Draglink, RH
63	817 00 05-12	Screw 5/16-18 x 3/4
64	532 19 98-49	Retainer Clip Spring Steering
65	532 19 47-34	Brace Axle Front
66	871 02 07-48	Bolt Hex Fghd 7/16-14 x 3 Serr
67	532 19 47-37	Bushing PM Front Axle
68	873 90 07-00	Nut Lock Flange 7/16-14 Gr. 5
69	532 19 91-62	Washer 1.5 x .505 x .118
70	585 33 88-01	Bracket Deck Susp. Front
75	580 68 37-01	Pinion
76	580 68 36-01	Screw Head Sock
78	532 05 70-79	Washer Thrust
122	532 44 49-62	Cap Gear Sector

**NOTE:** All component dimensions given in U.S. inches  
1 inch = 25.4 mm



**TRACTOR - MODEL NO. GT52XLS (96043015903), PRODUCT NO. 960 43 01-59  
MOWER DECK**

<b>KEY NO.</b>	<b>PART NO.</b>	<b>DESCRIPTION</b>	<b>KEY NO.</b>	<b>PART NO.</b>	<b>DESCRIPTION</b>
1	574 80 44-02	Deck 52"	36	532 19 51-85	Arm, Susp., Rear
2	539 13 18-98	Housing Assembly	37	539 11 36-21	Sb 3/8-16 x 3/8 Skt Hd
3	539 18 76-90	Washer-Spacer	38	819 13 13-16	Washer 13/32 x 13/16 x 16 Ga.
4	532 17 43-75	Pulley Driven Deck	39	539 20 02-82	Nut, 3/8-16 Hex Jam Nyloc
5	539 40 02-34	Nut, 9/16 Top Center Lock	40	532 17 60-66	Roller Nose
7	539 11 07-33	Discharge Chute	41	532 17 91-27	Rod Roller Nose
8	539 11 07-35	Spring - Torsion	43	819 12 14-14	Washer 3/8 x 7/8 x 14 Ga.
9	539 11 07-36	Pin, Clevis 5/16 x 5.19	44	575 96 73-02	Shield, Belt RH
10	574 87 08-01	Blade, 16-1/4"	45	874 78 05-16	Bolt Fin Hex 5/16-18 unc x 1
11	532 19 30-03	Bolt, 7/16, Assy Blade	46	810 03 05-00	Washer 5/16
12	574 87 50-02	Confinement Plate	49	584 95 39-01	Bolt 313-18 x 1.19
13	872 11 05-05	Bolt Carr 5/16-18 x 5/8	50	532 41 55-98	Washout Port
14	873 80 05-00	Nut 5/16-18 Hex	51	817 49 04-08	Bolt, 1/4-20 x 1/2
15	532 19 51-61	Stud, Fasten w/ Anti- Rotate	52	874 78 07-40	Bolt Hex 7/16-14 x 2-1/2
16	873 90 06-00	Nut Lock Flg. 7/16-14 Gr. 5	53	574 84 56-03	Belt, Deck
17	532 19 61-04	Pulley, Idler Spec. Hub	54	532 14 10-43	Guard TUV Idler
18	574 84 18-02	Arm, Idler, Blk	55	539 11 55-74	Eyebolt 5/16 x 3-1/2
19	532 17 79-68	Pulley, Idler	57	539 10 68-50	Spring
20	539 13 27-28	Pulley, Idler	58	532 11 04-85	Ball Bearing
21	575 22 45-01	Idler Bushing	59	575 35 29-01	Pulley
22	532 13 39-57	Wheel, Gauge	60	532 16 94-84	Clip Retainer
23	532 19 34-06	Bolt, Shoulder	61	532 40 03-37	Rod Anti-Sway
24	521 99 65-01	Nut 3/8-16 Hex Flg Nyloc	62	819 13 13-12	Washer 13/32 x 13/16 x 12 Ga.
25	575 22 47-02	Shield, Belt LH	63	532 19 42-08	Pin Cotter 5/16 Bow Tie Lock
27	539 10 47-63	Retainer 5/16c U Type	64	532 18 72-91	Shaft Asm. Mandrel
28	539 10 82-71	Hcs 3/8-16 x 3-1/2 Gr 5	--	532 41 64-05	Coupling Quick Connect
29	539 10 65-04	Heavy Washer	--	501 69 86-01	Mower Deck Complete
30	819 14 16-14	Washer, 3/8 Flat Std			
31	539 97 69-79	Nut 3/8-16 Hex Nyloc			
32	539 99 09-23	Rhsnb 3/8-16 x 1-3/4 Gr 5			
33	539 10 48-64	Washer, 7/16 Flat			
34	532 17 85-15	Washer, Flat Hardened			
35	873 90 07-00	Nut Lock Flange 7/16-14 Gr. 5			

**NOTE:** All component dimensions given in U.S. inches  
1 inch = 25.4 mm

**TRACTOR - MODEL NO. GT52XLS (96043015903), PRODUCT NO. 960 43 01-59  
MOWER LIFT**

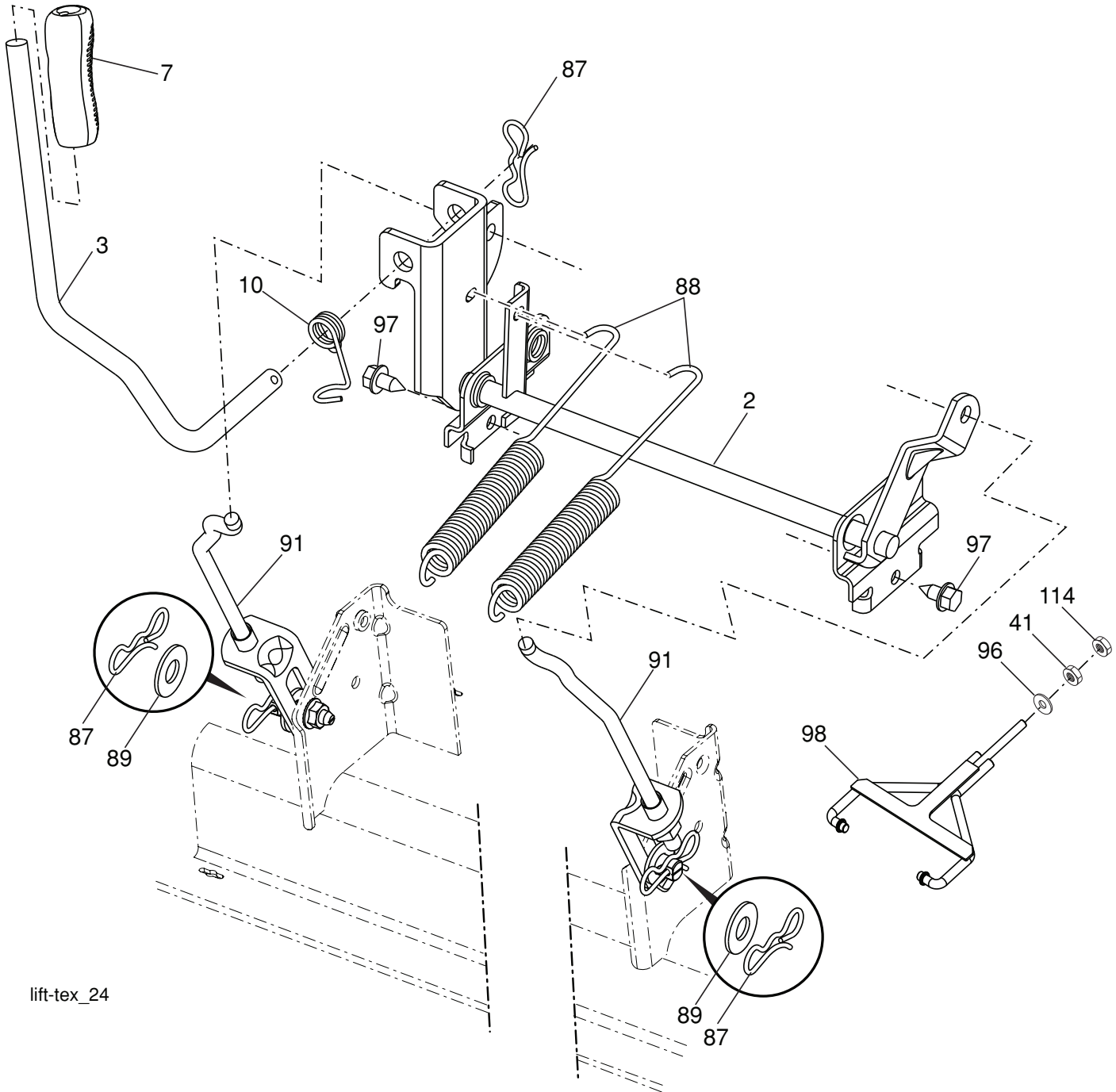

lift-tex\_24

KEY NO.	PART NO.	DESCRIPTION
2	532 42 20-27	Shaft Asm., Lift
3	532 19 52-30	Lever Asm., Lift RH
7	580 96 23-01	Grip, Lever
10	532 19 63-14	Spring Torsion
41	532 17 59-94	Nut Lift Link
87	532 19 42-09	Pin Cotter 7/16 Bow Tie Lock
88	532 19 53-04	Spring Lift Assist
89	819 19 19-12	Washer Clear Zinc

KEY NO.	PART NO.	DESCRIPTION
91	532 40 34-07	Link Lift Susp Mower Rear
96	532 19 52-63	Bushing Spherical
97	817 00 06-12	Screw 3/8-16 x .75
98	574 82 25-01	Link Lift Susp. Front Mower
114	873 36 07-00	Nut Jam 7/16-20

**NOTE:** All component dimensions given in U.S. inches  
1 inch = 25.4 mm



**TRACTOR - MODEL NO. GT52XLS (96043015903), PRODUCT NO. 960 43 01-59  
SEAT ASSEMBLY**

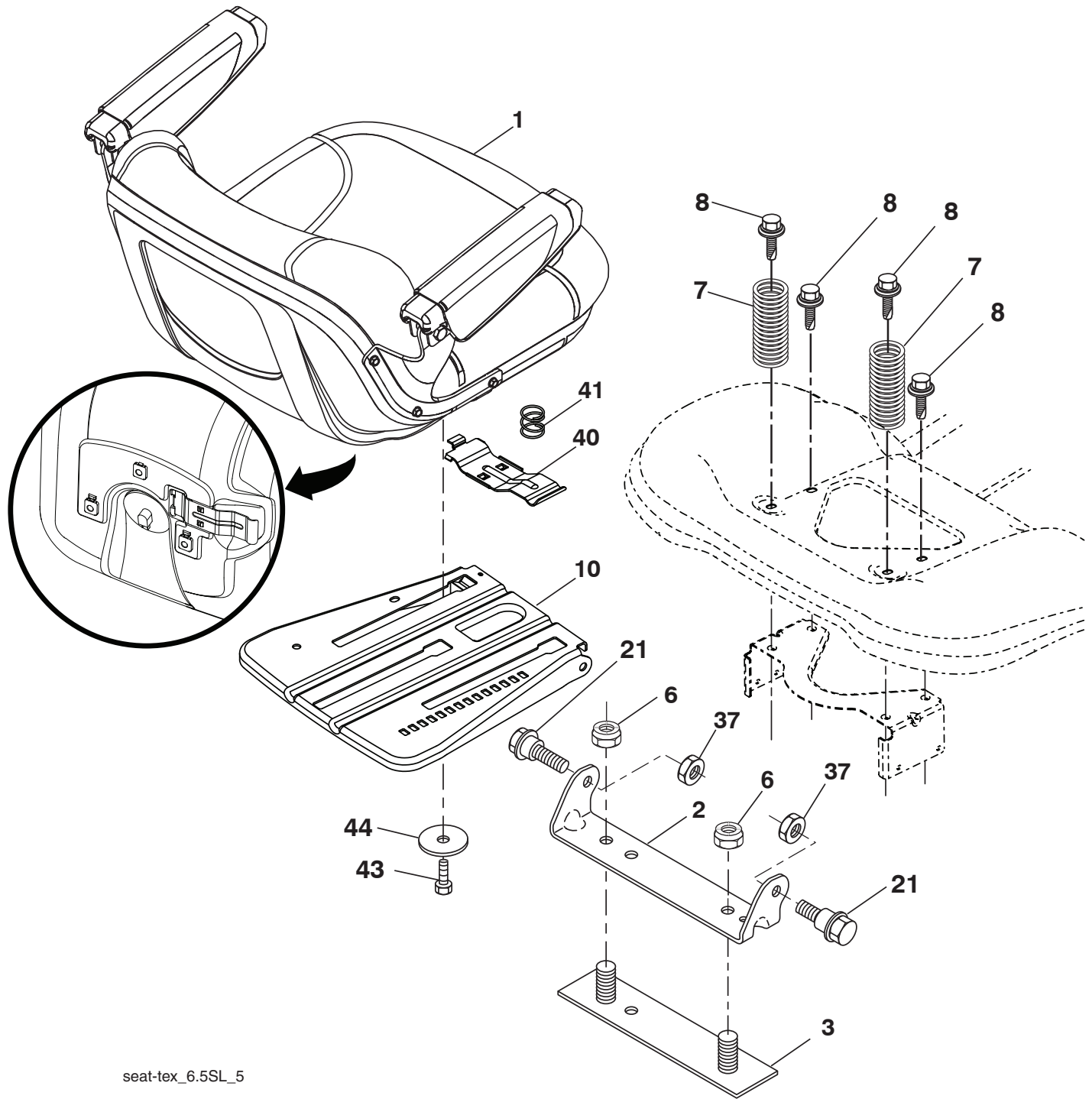

seat-tex\_6.5SL\_5

KEY NO.	PART NO.	DESCRIPTION
1	532 44 32-63	Seat
2	532 18 01-66	Bracket Pivot Fender
3	532 14 06-75	Strap, Asm Fender
6	873 80 06-00	Nut, Lock w/Ins. 3/8-16 unc
7	587 61 33-01	Spring, Seat Cprsn
8	532 17 18-77	Bolt 5/16-18 unc x 3/4 w/Sems
10	532 19 69-77	Pan, Seat
21	587 90 78-01	Bolt, Shoulder 5/16-18 x 5/8

KEY NO.	PART NO.	DESCRIPTION
37	873 80 05-00	Nut, Lock 5/16-18 unc
40	532 43 98-71	Handle Slide Seat
41	532 19 82-00	Spring Latch Seat
43	874 76 06-12	Bolt Fin Hex 3/8-16 unc x 3/4
44	819 13 38-12	Washer 13/32 x 2-3/8 x 12 Ga.

**NOTE:** All component dimensions given in U.S. inches  
1 inch = 25.4 mm

**TRACTOR - MODEL NO. GT52XLS (96043015903), PRODUCT NO. 960 43 01-59  
DECALS**

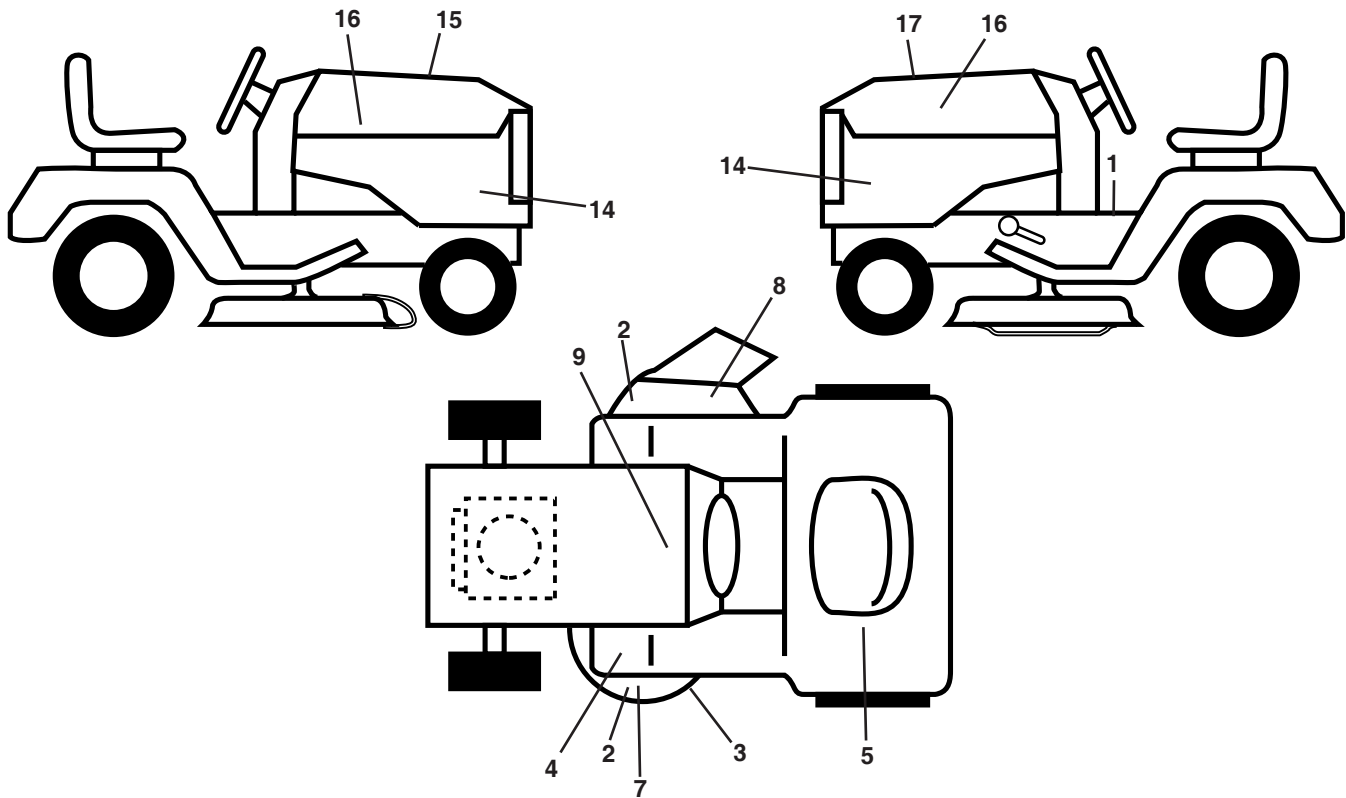

KEY NO.	PART NO.	DESCRIPTION
1	581 57 89-01	Decal, Warning
2	581 72 43-01	Decal, No Step
3	581 58 00-02	Decal, Mower Sch.
4	532 41 86-00	Decal, Pedal
5	587 01 51-01	Decal, Warning Reserve
7	532 44 81-21	Decal, Deck HV Reinforced
8	584 90 46-01	Decal, Deflect. Warning
9	532 14 50-05	Decal, Battery Dnge/Poi
14	581 54 97-01	Decal, Panel Side
15	532 42 38-29	Decal, Cust. Resp.

KEY NO.	PART NO.	DESCRIPTION
16	581 62 73-01	Decal, Hood Logo
17	501 67 38-01	Decal, Replacement
--	581 72 48-01	Decal, Bypass
--	532 43 98-82	Pad, Footrest, LH
--	532 43 98-81	Pad, Footrest, RH
--	115 78 89-26	Manual, Operator's (English/Spanish)
--	115 78 90-27	Manual, Part's (English/Spanish)
--	587 71 00-26	Manual, QSG Husq (English/Spanish)

**WHEELS AND TIRES**

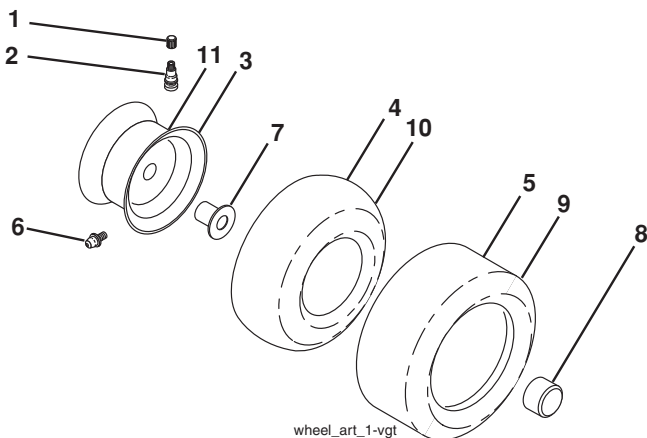

KEY NO.	PART NO.	DESCRIPTION
1	532 05 91-92	Cap, Valve, Tire
2	532 06 51-39	Stem, Valve
3	532 18 18-39	Rim Assembly, Front
4	532 00 81-34	Tube, Front (Service Item Only)
5	532 16 10-24	Tire, Front 16 x 6.5-8
6	532 12 49-57	Fitting, Grease (Front Wheel Only)
7	532 12 49-59	Bearing, Flange (Front Wheel Only)
8	532 17 50-39	Cap, Axle (Front Wheel Only)
9	532 17 04-53	Tire, Rear 23 x 10.5-12
10	532 00 71-54	Tube, Rear (Service Item Only)
11	532 14 45-10	Rim Assembly, Rear
--	532 14 43-34	Sealant, Tire (10 oz. Tube)

**NOTE:** All component dimensions given in U.S. inches  
1 inch = 25.4 mm

# TRACTOR MODELO NO. GT52XLS (96043015903), PRODUCTO NO. 960 43 01-59

## DIAGRAMA

SCH12-s

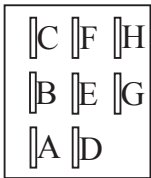
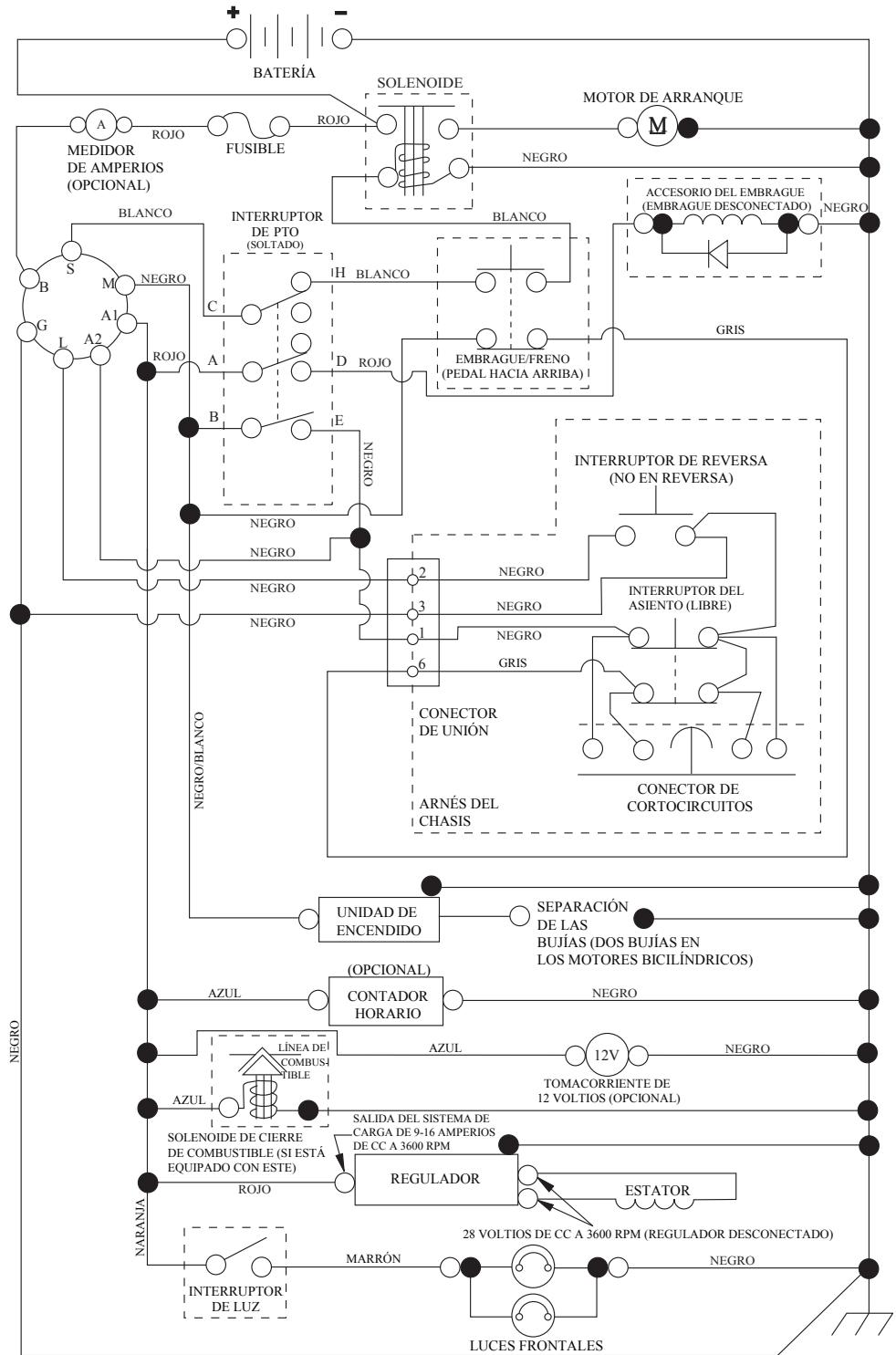

INTERRUPTOR DE PTO (CARA DE ACOPLAMIENTO)

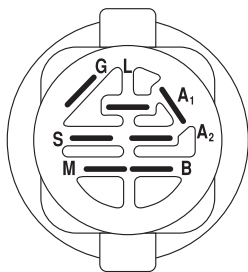

INTERRUPTOR DE ENCENDIDO

POSICIÓN	CIRCUITO «MARCA»
APAGADO	M+G+A1
PONER EN FUNCIONAMIENTO/ANULAR	B+A1
PONER EN FUNCIONAMIENTO	B+A1 L+A2
ARRANCAR	B + S + A1

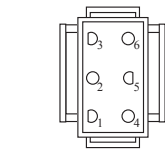

CONEXIÓN DEL ARNÉS DEL CHASIS (LATERAL QUE COINCIDA)

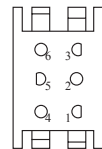

CONEXIÓN PARA EL ARNÉS DEL TABLERO

NOTA SOBRE LAS ABRAZADERAS DE AISLAMIENTO DEL CABLEADO: SI SE QUITAN LAS ABRAZADERAS DE AISLAMIENTO DEL CABLEADO PARA HACER EL MANTENIMIENTO DE LA UNIDAD, SE LAS DEBERÁ INSTALAR NUEVAMENTE PARA PROTEGER EL CABLEADO ADECUADAMENTE.

● CONEXIONES NO DESMONTABLES

○ CONEXIONES DESMONTABLES

DIAGRAMA ELÉCTRICO

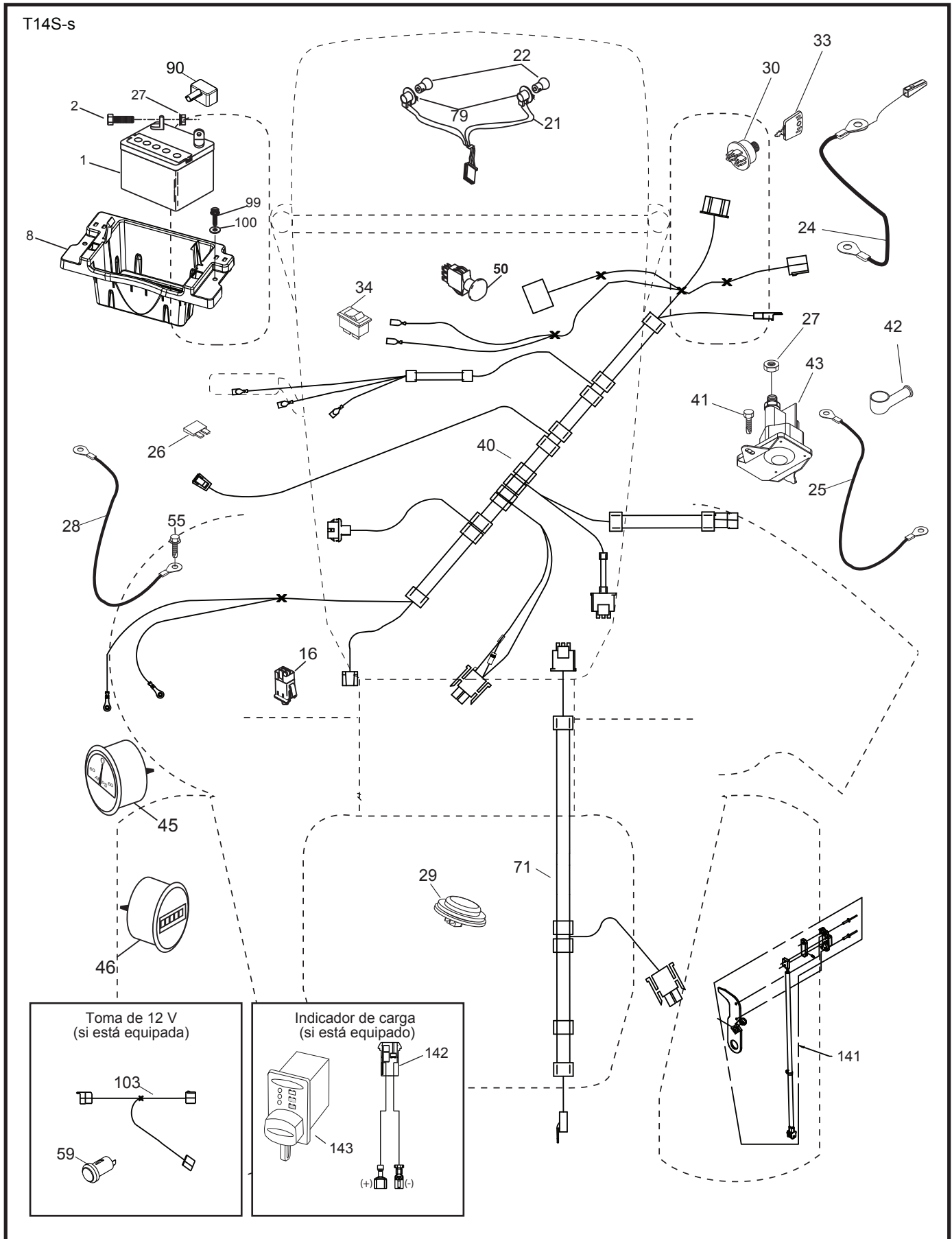

**TRACTOR MODELO NO. GT52XLS (96043015903), PRODUCTO NO. 960 43 01-59**  
**DIAGRAMA ELÉCTRICO**

<b>CÓDIGO No.</b>	<b>PIEZA No.</b>	<b>DESCRIPCIÓN</b>
1	532 16 34-65	Batería
2	874 76 04-12	Perno de cabeza hexagonal de 1/4-20 x 3/4
8	587 20 51-01	Caja de la batería
16	532 17 61-38	Interruptor corta corriente a presión
21	532 40 02-52	Cableado del enchufe para la luz
22	532 00 41-52	Bombilla de luz
24	585 55 56-01	Cable
25	585 55 55-01	Cable
26	532 17 51-58	Fusible
27	873 51 04-00	Tuerca hexagonal Keps de 1/4-20 unc
28	532 41 65-88	Cable a tierra
29	532 40 15-45	Interruptor del asiento
30	532 19 33-50	Interruptor de encendido
33	532 41 19-33	Llave/cadena
34	532 11 07-12	Interruptor de luz/de restauración
40	501 13 31-01	Cableado de encendido
41	817 72 04-08	Tornillo
42	532 13 15-63	Cubierta de la terminal
43	532 19 25-07	Solenoides
45	587 55 39-03	Indicador SRVCMNDR
46	587 55 40-03	Indicador HRMTR
50	532 17 46-51	Interruptor
55	817 06 05-12	Tornillo de 5/16-18 x 3/4
59	532 40 03-03	Enchufe, 12V
71	532 19 42-76	Cableado de encendido, chasis
79	532 17 52-42	Enchufe de cierre por torsión del ensamble de la bombilla
90	532 43 53-95	Tapa de los bornes de la batería
99	817 67 04-12	Tornillo 1/4-20 x 3/4
100	819 09 14-16	Arandela
103	532 42 17-47	Cable 12V
141	532 42 12-25	G700/G730 ROS
142	583 85 78-01	Cableado de conector de carga
143	532 44 80-59	Conector de carga

**NOTA:** Las dimensiones de todos los componentes están expresadas en pulgadas americanas. 1 pulgada = 25,4 mm

TRACTOR MODELO NO. GT52XLS (96043015903), PRODUCTO NO. 960 43 01-59  
CHASIS

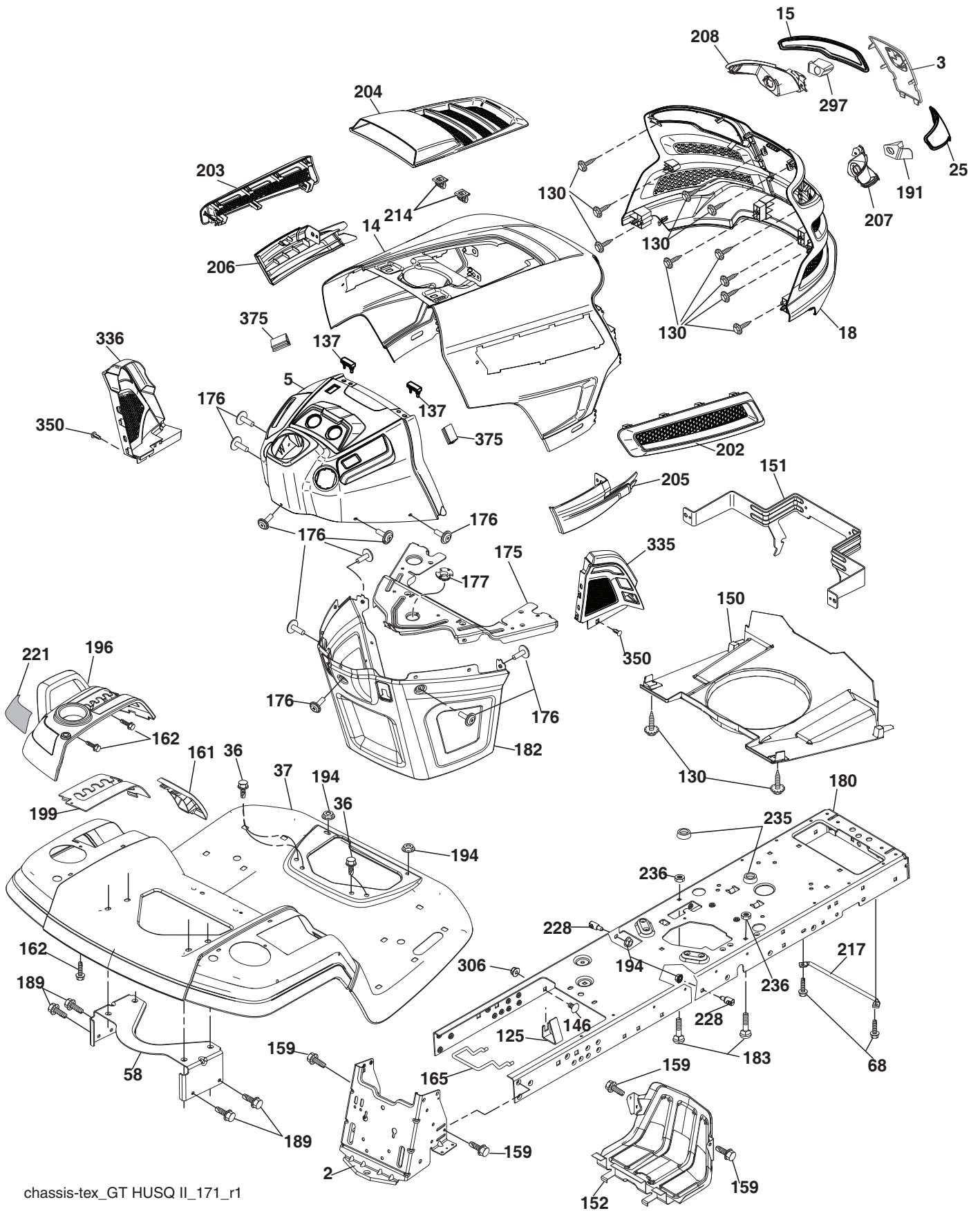

chassis-tex\_GT HUSQ II\_171\_r1

**TRACTOR MODELO NO. GT52XLS (96043015903), PRODUCTO NO. 960 43 01-59  
CHASIS**

<b>CÓDIGO No.</b>	<b>PIEZA No.</b>	<b>DESCRIPCIÓN</b>	<b>CÓDIGO No.</b>	<b>PIEZA No.</b>	<b>DESCRIPCIÓN</b>
2	580 43 44-01	Barra de tracción	196	532 43 96-74	Ensamble de la consola de la plataforma de elevación
3	532 44 44-81	Aplica Submontaje	199	532 19 82-59	Chapa
5	532 43 74-75	Tablero	202	532 43 97-28	Salida de Ventilación (LD)
14	532 44 11-77	Capota	203	532 43 97-27	Salida de Ventilación (LI)
15	532 43 97-33	Lente izquierdo de la parrilla	204	532 43 57-14	Salida de Ventilación superior
18	532 44 06-53	Parrilla	205	532 43 97-30	Camisa de Capota (LD)
25	532 44 33-85	Lente derecho de la parrilla	206	532 43 97-29	Camisa de Capota (LI)
36	817 06 05-12	Tornillo de 5/16-18 x 3/4	207	532 43 97-34	Bisel derecho
37	532 44 12-08	Guardabarros	208	532 43 97-35	Bisel izquierdo
58	532 19 43-14	Soporte de Guardabarros	214	532 19 91-45	Cierre
68	817 49 05-08	Tornillo de 5/16-18 x 1/2	217	532 40 91-67	Varilla giratoria
125	581 68 48-01	Soporte	218	532 19 63-95	Tope
130	532 41 63-58	Tornillo No. 10 x 0,75	221	532 19 89-09	Reflector (LI)
137	532 40 75-90	Cubierta Tablero	228	532 19 51-61	Sujetador del travesaño
146	581 85 79-01	Perno	235	532 40 61-29	Separador del guardabarros
150	532 43 97-74	Cubierta	236	873 93 05-00	Tuerca de presión 5/16-18 unc
151	532 43 66-70	Soporte de Capota	297	532 43 74-56	Parte movable reflexivo (LI)
152	532 43 98-70	Protector contra oscurecimiento	306	873 90 06-00	Tuerca
159	817 00 06-12	Tornillo 3/8-16 x 3/4	335	532 44 82-04	Cubierta (LD)
161	532 43 99-29	Ventanilla de combustible	336	532 44 53-09	Cubierta (LI)
162	532 14 24-32	Tornillo	350	532 44 51-43	Cierre del árbol de navidad
165	532 19 43-30	Soporte de Tanque de Gasolina	375	586 90 82-01	Cubierta Capota
175	532 19 63-04	Travesaño	--	532 43 18-82	Protector del cepillo
176	532 40 07-76	Tornillo de 10-24 x 5/8			
177	532 19 52-28	Buje de dirección			
180	532 44 55-59	Chasis			
182	532 40 68-59	Tablero inferior			
183	874 52 05-20	Perno 5/16-18 x 1-1/4			
189	817 00 05-12	Tornillo			
191	532 43 74-55	Parte movable reflexivo (LD)			
194	873 90 05-00	Tuerca de presión de 5/16-18			

**NOTA:** Las dimensiones de todos los componentes están expresadas en pulgadas americanas. 1 pulgada = 25,4 mm



TRACTOR MODELO NO. GT52XLS (96043015903), PRODUCTO NO. 960 43 01-59  
TRANSMISIÓN

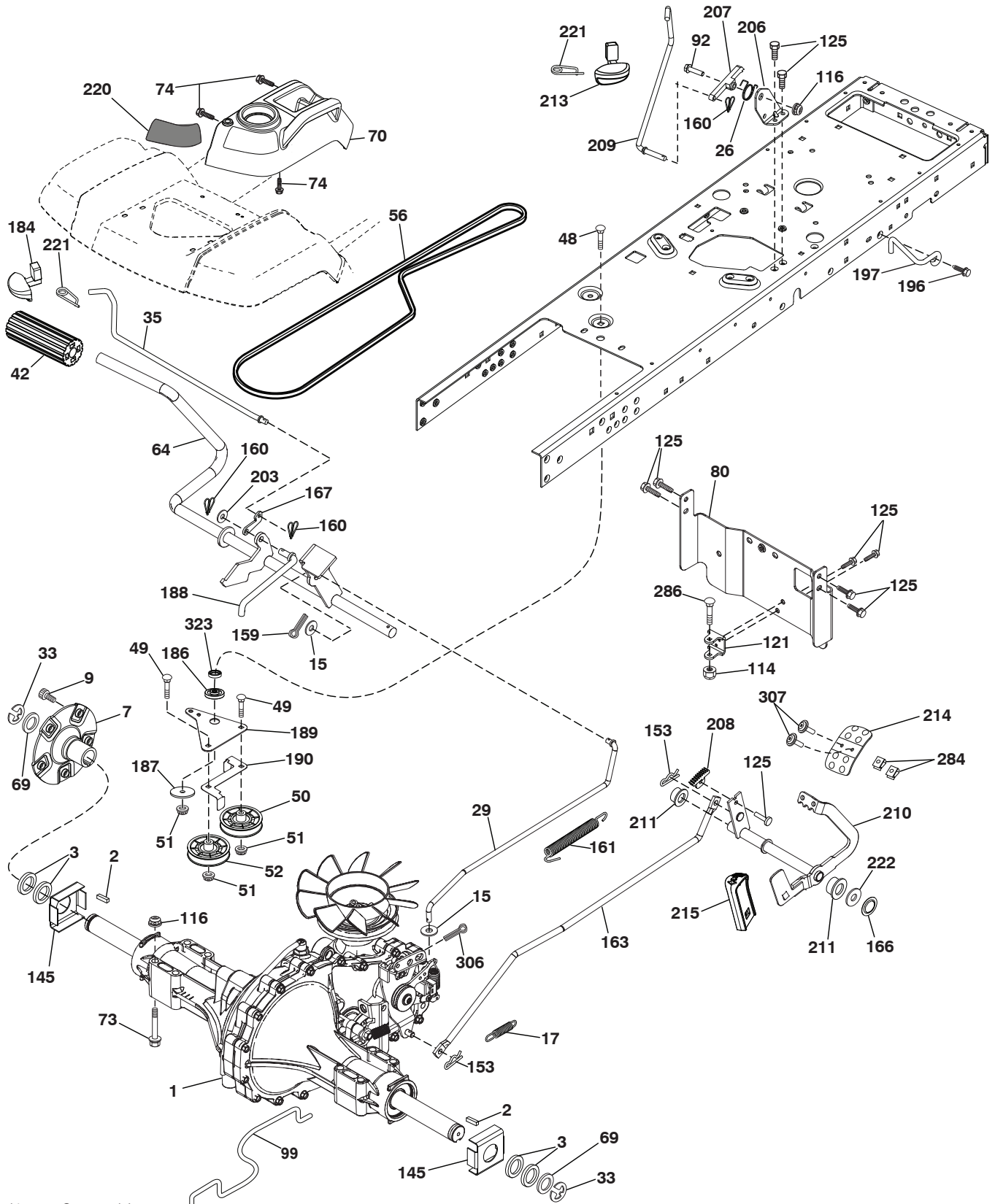

drive-tex\_G730\_pedal\_6\_r2



# TRACTOR MODELO NO. GT52XLS (96043015903), PRODUCTO NO. 960 43 01-59

## TRANSMISIÓN

CÓDIGO No.	PIEZA No.	DESCRIPCIÓN	CÓDIGO No.	PIEZA No.	DESCRIPCIÓN
1	---	Transeje, Hydro G7-BCBB-1XDC-1FCA (420331)(Haga el pedido de las piezas al fabricante del transeje.)	163	532 41 81-85	Control del pedal de la barra
2	532 00 70-70	Llave	166	532 42 91-64	Tuerca
3	532 00 75-63	Tuerca	167	532 40 52-57	Pestillo del freno de mano
7	532 19 98-37	Ensamble del cubo trasero	184	587 65 37-01	Manija del freno de mano
9	532 14 00-80	Perno	186	532 19 43-21	Espaciador de retención
15	819 13 13-16	Arandela 13/32 x 13/16 x calibre 16	187	819 13 32-10	Arandela
17	532 19 72-96	Resorte de freno	188	532 19 43-23	Mecanismo de desplazamiento de la varilla de mando del embrague
26	532 19 96-79	Resorte de travesía	189	532 40 75-04	Palanca acodada del mecanismo de desplazamiento
29	532 41 81-86	Varilla del freno	190	532 40 75-05	Sujetador de la palanca acodada del mecanismo de desplazamiento
33	812 00 00-53	Aro "E"	196	817 00 06-16	Tornillo 3/8-16 x 1
35	583 86 45-01	Varilla del freno de mano	197	585 65 86-01	Mecanismo de desplazamiento
42	532 12 48-72	Cubierta del pedal	203	819 11 11-16	Tuerca 11/32 x 11/16 x calibre 16
48	872 11 06-12	Tornillo 3/8-16 x 1-1/2 grado 5	206	532 44 85-96	Soporte de la travesía
49	872 11 06-14	Perno	207	587 03 14-01	Cierre del control de travesía
50	532 19 43-27	Polea loca plana	208	532 19 78-69	Travesía del control del sector
51	873 90 06-00	Tuerca de presión de 3/8-16	209	532 19 95-92	Travesía del control de Rod
52	532 19 43-26	Polea loca con ranura en V con un desplazamiento	210	532 19 78-60	Ensamble del eje de balancín. Control del pedal
56	532 42 08-07	Correa trapezoidal de la transmisión	211	532 12 01-83	Buje
64	532 19 78-65	Ensamble del eje Control del pedal de freno	213	532 40 31-19	Travesía del control de la perilla
69	532 12 38-00	Tuerca 1-1/32 x 1-5/8 x calibre 16	214	532 41 68-63	Pedal adelante
70	532 43 96-61	Ensamble de la consola	215	532 40 17-23	Revés del pedal
73	874 49 05-48	Perno 5/16-18 3.75	220	532 19 89-08	Reflector derecho
74	532 14 24-32	Tornillo 1/4 x 1/2	221	532 40 31-87	Abrazadera de retención del resorte de la manija
80	532 41 81-84	Correa de torsión	222	879 21 20-10	Tuerca 21/32 x 1-1/4 x calibre 10
92	874 76 05-20	Tornillo 5/16-18 x 1/2	284	532 41 76-93	Tuerca 1/4-20
99	532 41 81-88	Varilla de desviación	286	872 01 05-20	Tornillo 5/16-18 x 2.50
114	873 80 05-00	Tuerca 5/16-18 unc	306	876 02 04-16	Pasador de chaveta de 1/8 x 1
116	873 90 05-00	Tuerca 5/16-18	307	874 18 04-12	Tornillo 1/4-20 x 3/4
121	532 17 56-11	Bracket Strap Torque	323	585 71 41-01	Manga
125	817 00 05-12	Tornillo 5/16-18 x 3/4			
145	532 16 31-68	Tuerca			
153	532 12 47-88	Retén del resorte			
159	876 02 04-12	Pasador de chaveta de 1/8 x 3/4			
160	532 16 94-84	Abrazadera de retención			
161	532 10 57-09	Resorte de retorno del embrague			

**NOTA:** Las dimensiones de todos los componentes están expresadas en pulgadas americanas. 1 pulgada = 25,4 mm

TRACTOR MODELO NO. GT52XLS (96043015903), PRODUCTO NO. 960 43 01-59  
MOTOR

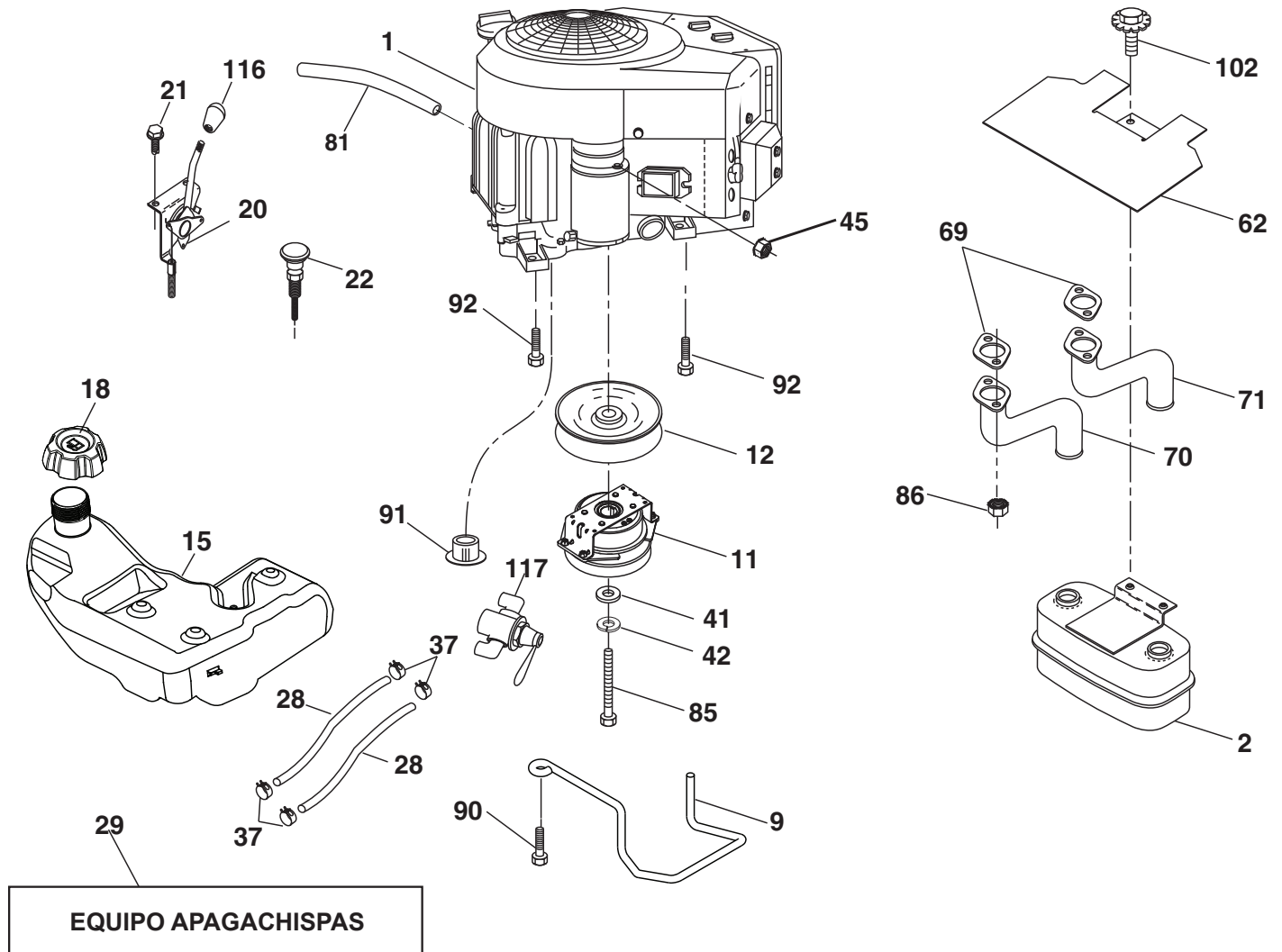

engine-tex\_Kawa-2cyl\_49\_r1

**TRACTOR MODELO NO. GT52XLS (96043015903), PRODUCTO NO. 960 43 01-59  
MOTOR**

<b>CÓDIGO No.</b>	<b>PIEZA No.</b>	<b>DESCRIPCIÓN</b>
1	- - - - -	Motor KAWA modelo No. FR730V-DS04 (445363)(Haga el pedido de las piezas al fabricante del motor.)
2	532 44 59-62	Silenciador
9	532 40 86-67	Ensamble del sujetador de la correa del motor
11	587 24 14-01	Embrague de eléctrico
12	532 19 43-43	Polea del motor
15	532 43 80-82	Tanque de Gasolina de 4,0 R
18	585 12 48-01	Tapa
20	532 42 43-41	Control del regulador
21	532 41 63-58	Tornillo No. 10 x 0,75 con rosca reforzada
22	532 19 15-96	Control de la estrangulación del motor
28	532 40 11-35	Línea de combustible
29	532 13 71-80	Equipo apagachispas
37	532 12 34-87	Abrazadera de la manguera
41	532 12 61-97	Arandela 1-1/2 x 15/32 x .250
42	810 04 07-00	Arandela de presión de 7/16
45	873 51 04-00	Tuerca
62	532 14 66-29	Silenciador con pantalla térmica
69	532 17 81-51	Junta
70	583 95 56-01	Tubo de escape izquierdo
71	583 95 57-01	Tubo de escape derecho
81	532 14 84-56	Tubo de drenaje
85	581 63 62-01	Perno de 7/16-20 x 3.0 x grado 5
86	532 18 43-62	Tuerca
90	817 00 06-16	Tornillo de 3/8-16 x 1
91	532 18 74-95	Buje
92	817 12 06-16	Tornillo 3/8-16 x 1
102	817 00 05-12	Tornillo 5/16-18 x 3/4
116	539 13 26-24	Tacto suave de la perilla
117	532 42 08-28	válvula de la reserva del combustible

**NOTA:** Las dimensiones de todos los componentes están expresadas en pulgadas americanas. 1 pulgada = 25,4 mm  
Para las piezas del servicio y de recambio del motor, llame el número gratis para su fabricante del motor enumerado abajo:  
Kawasaki 1-949-460-5688

TRACTOR MODELO NO. GT52XLS (96043015903), PRODUCTO NO. 960 43 01-59  
ENSAMBLE DE LA DIRECCIÓN

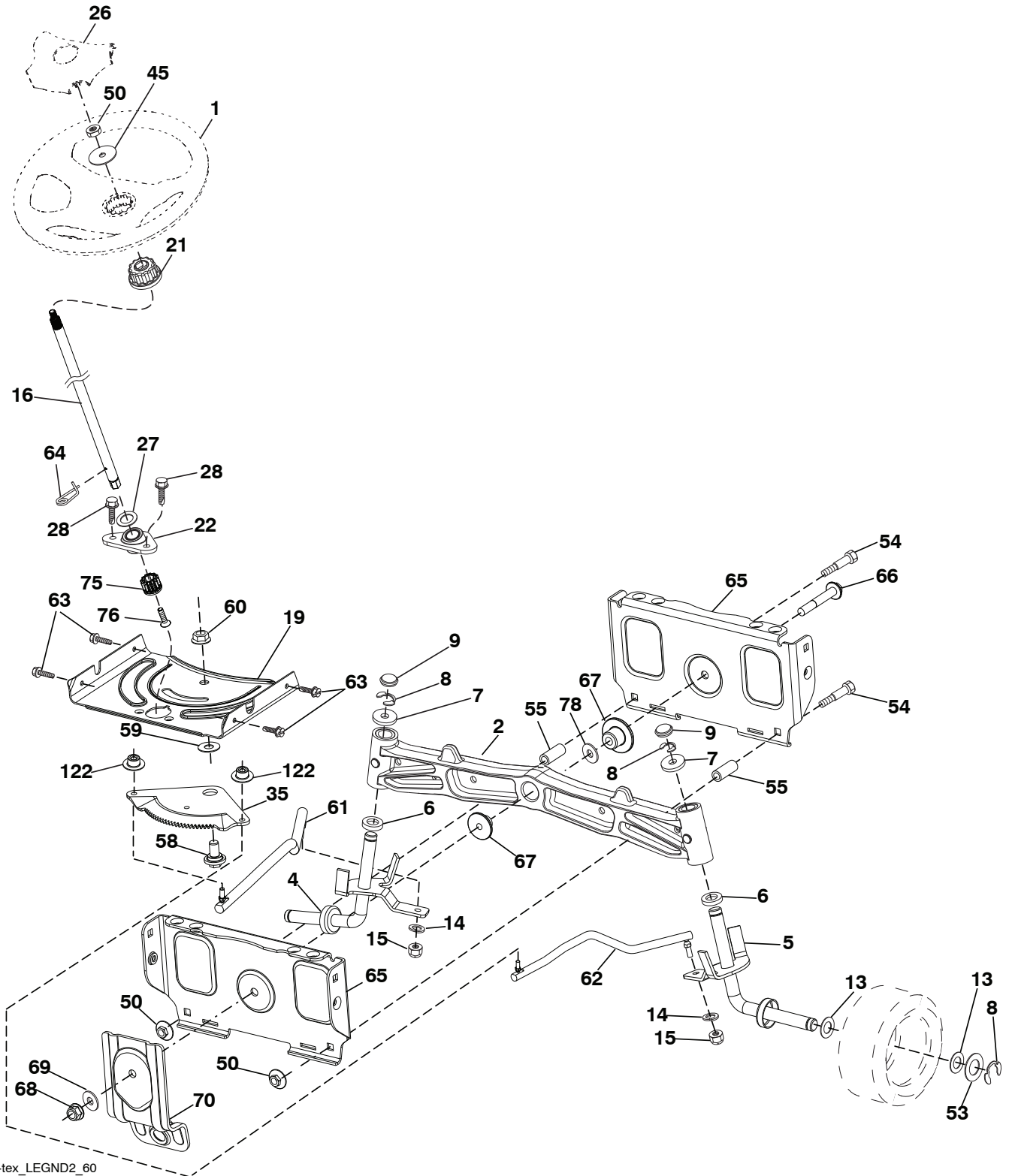

Steering-tex\_LEGND2\_60

**TRACTOR MODELO NO. GT52XLS (96043015903), PRODUCTO NO. 960 43 01-59  
ENSAMBLE DE LA DIRECCIÓN**

<b>CÓDIGO No.</b>	<b>PIEZA No.</b>	<b>DESCRIPCIÓN</b>
1	532 43 97-40	Volante de dirección
2	532 19 59-68	Ensamble del eje delantero
4	532 40 30-89	Ensamble del husillo izquierdo
5	532 40 30-90	Ensamble del husillo derecho
6	532 12 49-31	Pista del rodamiento para reforzar el impulso
7	532 12 17-48	Arandela de 25/32 x 1-5/8 calibre 16
8	812 00 00-29	Abrazadera del aro No. T5304-75
9	532 12 12-32	Tapa del husillo
13	532 12 17-49	Arandela de 25/32 x 1-1/4 calibre 16
14	810 04 06-00	Arandela de presión de 3/8
15	873 54 06-00	Tuerca de 3/8-24 unf
16	587 01 60-02	Eje de dirección
19	532 19 47-29	Placa de dirección
21	586 84 02-01	Adaptador del volante de dirección
22	585 02 98-02	Rodamiento
26	532 43 97-43	Inserto del volante de dirección
27	819 21 16-16	Arandela
28	817 00 06-12	Tornillo de 3/8-16 x 3/4
35	532 19 47-32	Engranaje del sector de la placa
45	587 01 64-01	Arandela 3/8 ID 2-3/8 OD calibre 12 PLTD
50	873 90 06-00	Tuerca 3/8-16 unc
53	532 18 89-67	Arandela reforzada de, 793 x 1,637 x 0,060
54	874 76 06-36	Tornillo 3/8-16 unc x 2-1/4
55	532 41 47-36	Tornillo 3/8-16 unc x 2-1/4
58	532 19 47-47	Perno de tope del sector del pivote CFM
59	532 19 47-48	Arandela de empuje del sector de dirección
60	873 97 10-00	Tuerca de 5/8-11
61	532 19 47-40	Barra de acoplamiento izquierda
62	532 19 47-41	Barra de acoplamiento derecha
63	817 00 05-12	Tornillo de 5/16-18 x 3/4
64	532 19 98-49	Abrazadera de retención del resorte de la dirección
65	532 19 47-34	Apoyo del árbol delantero
66	871 02 07-48	Perno de cabeza hexagonal con brida acanalada de 7/16-14 x 3
67	532 19 47-37	Buje PM del eje delantero
68	873 90 07-00	Tuerca de 7/16-14 grado 5
69	532 19 91-62	Arandela de 1,5 x 0,505 x 0,118
70	585 33 88-01	Soporte de la plataforma delantera
75	580 68 37-01	Piñón
76	580 68 36-01	Tornillo
78	532 05 70-79	Tuerca
122	532 44 49-62	Tapa

**NOTA:** Las dimensiones de todos los componentes están expresadas en pulgadas americanas. 1 pulgada = 25,4 mm

TRACTOR MODELO NO. GT52XLS (96043015903), PRODUCTO NO. 960 43 01-59  
PLATAFORMA DE LA CORTADORA DE CÉSPED

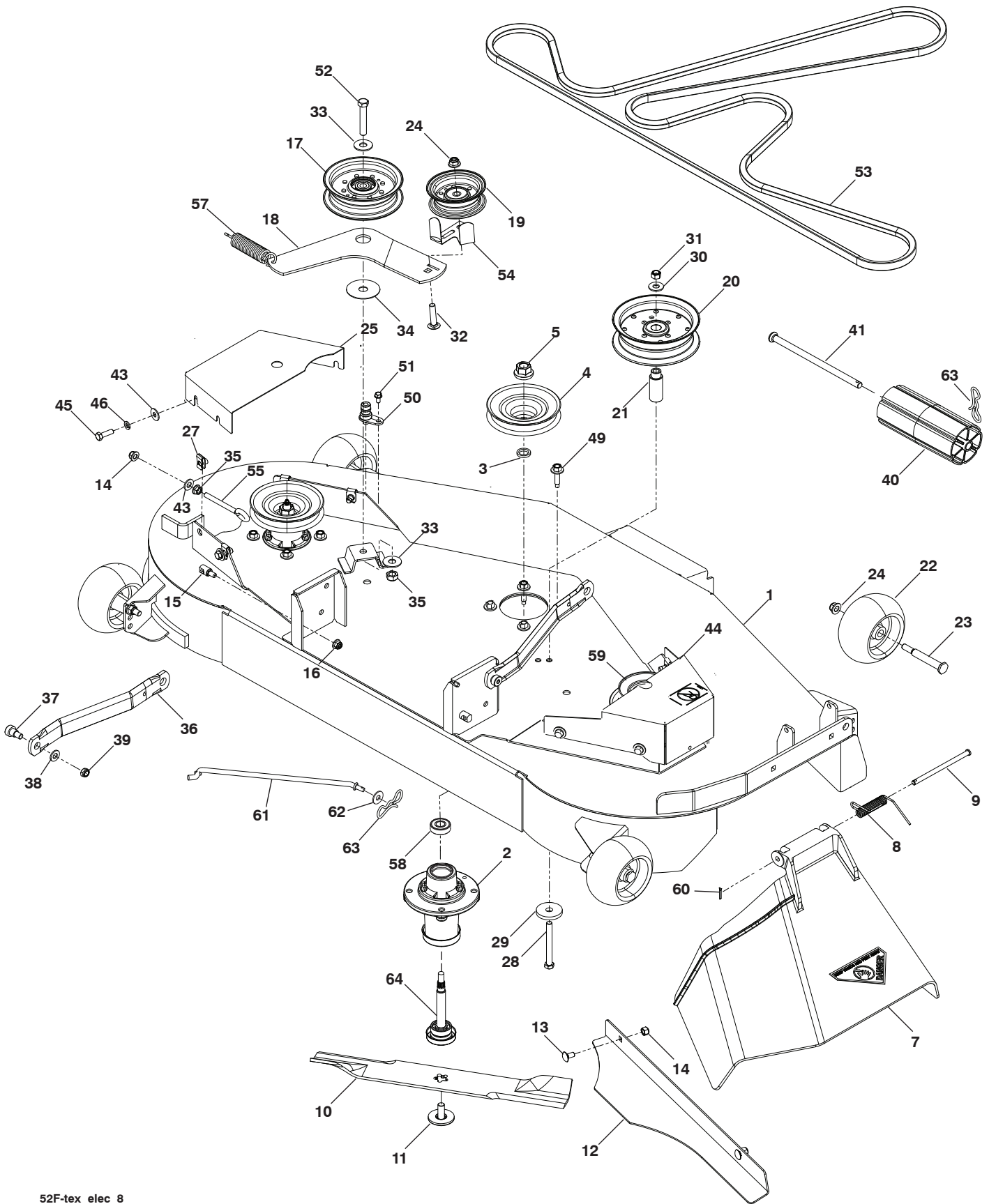

**TRACTOR MODELO NO. GT52XLS (96043015903), PRODUCTO NO. 960 43 01-59  
PLATAFORMA DE LA CORTADORA DE CÉSPED**

<b>CÓDIGO No.</b>	<b>PIEZA No.</b>	<b>DESCRIPCIÓN</b>	<b>CÓDIGO No.</b>	<b>PIEZA No.</b>	<b>DESCRIPCIÓN</b>
1	574 80 44-02	Cubierta 52"	38	819 13 13-16	Arandela 13/32 x 13/16 x 16
2	539 13 18-98	Ensamble de la cubierta	39	539 20 02-82	Tuerca 3/8-16
3	539 18 76-90	Arandela	40	532 17 60-66	Rodillo de la nariz
4	532 17 43-75	Polea	41	532 17 91-27	Rod, rodillo de la nariz
5	539 40 02-34	Tuerca 9/16	43	819 12 14-14	Arandela 3/8 x 7/8 x 14 calibre
7	539 11 07-33	Canal inclinado de la descarga	44	575 96 73-02	Protector de la correa LD
8	539 11 07-35	Resorte - torsión	45	874 78 05-16	Perno 5/16-18 unc x 1
9	539 11 07-36	Clavija de horquilla 5/16 x 5.19	46	810 03 05-00	Arandela 5/16
10	574 87 08-01	Lámina, 16-1/4"	49	584 95 39-01	Perno 313-18 x 1.19
11	532 19 30-03	Perno, 7/16	50	532 41 55-98	Puerto del derrubio
12	574 87 50-02	Placa del confinamiento	51	817 49 04-08	Perno 1/4-20 x 1/2
13	872 11 05-05	Perno 5/16-18 x 5/8 grado 5	52	874 78 07-40	Perno 7/16-14 x 2-1/2
14	873 80 05-00	Tuerca 5/16-18	53	574 84 56-03	Correa, cubierta
15	532 19 51-61	Sujetador del perno prisionero	54	532 14 10-43	Protector, correa
16	873 90 06-00	Tuerca 7/16-14 Gr. 5	55	539 11 55-74	Perno de argolla 5/16 x 3-1/2
17	532 19 61-04	Polea más ociosa	57	539 10 68-50	Resorte
18	574 84 18-02	Brazo más ocioso	58	532 11 04-85	Rodamiento de bolitas
19	532 17 79-68	Polea más ociosa	59	575 35 29-01	Polea
20	539 13 27-28	Polea más ociosa	60	532 16 94-84	Detenedor del clip
21	575 22 45-01	Buje más ocioso	61	532 40 03-37	Varilla
22	532 13 39-57	Rueda, calibrador	62	819 13 13-12	Arandela 13/32 x 13/16 x calibre 12
23	532 19 34-06	Perno	63	532 19 42-08	Pasador de chaveta de 5/16 con bloqueo en forma de mariposa
24	521 99 65-01	Tuerca 3/8-16	64	532 18 72-91	Conjunto del eje del mandril
25	575 22 47-02	Protector, correa LI	--	532 41 64-05	Accesorio del conexión
27	539 10 47-63	Detenedor 5/16	--	501 69 86-01	Cubierta del cortacéspedes completa
28	539 10 82-71	Hcs 3/8-16 x 3-1/2 grado 5			
29	539 10 65-04	Arandela			
30	819 14 16-14	Arandela 3/8			
31	539 97 69-79	Tuerca 3/8-16			
32	539 99 09-23	Rhsnb 3/8-16 x 1-3/4 grado 5			
33	539 10 48-64	Arandela 7/16 Flat			
34	532 17 85-15	Arandela			
35	873 90 07-00	Tuerca 7/16-14			
36	532 19 51-85	Suspensión posterior del brazo			
37	539 11 36-21	Sb 3/8-16 x 3/8 Skt Hd			

**NOTA:** Las dimensiones de todos los componentes están expresadas en pulgadas americanas. 1 pulgada = 25,4 mm

**TRACTOR MODELO NO. GT52XLS (96043015903), PRODUCTO NO. 960 43 01-59**  
**ELEVACIÓN DE LA CORTADORA DE CÉSPED**

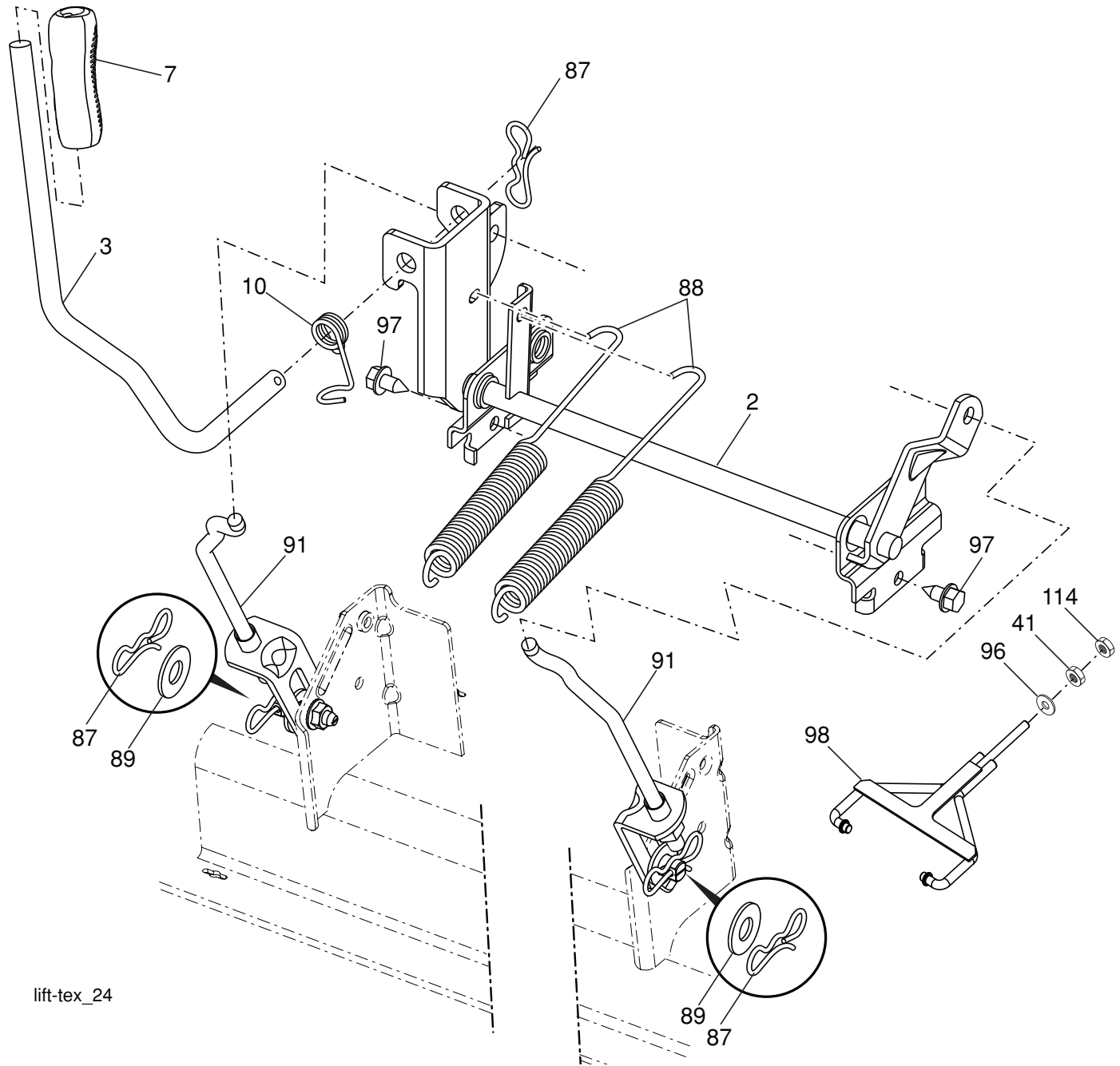

lift-tex\_24

CÓDIGO No.	PIEZA No.	DESCRIPCIÓN
2	532 42 20-27	Ensamble del eje de la elevación
3	532 19 52-30	Ensamble de la palanca de elevación derecha
7	580 96 23-01	Mango de la palanca
10	532 19 63-14	Resorte de torsión
41	532 17 59-94	Tuerca
87	532 19 42-09	Pasador de chaveta de 7/16 con bloqueo en forma de mariposa
88	532 19 53-04	Resorte de ayuda de la elevación
89	819 19 19-12	Arandela de zinc transparente

CÓDIGO No.	PIEZA No.	DESCRIPCIÓN
91	532 40 34-07	Ensamble del acoplamiento Elevación trasera
96	532 19 52-63	Buje
97	817 00 06-12	Tornillo de 3/8-16 x 0,75
98	574 82 25-01	Acoplamiento frontal de la elevación de la cortadora de césped
114	873 36 07-00	Tuerca 7/16-20

**NOTA:** Las dimensiones de todos los componentes están expresadas en pulgadas americanas. 1 pulgada = 25,4 mm



**TRACTOR MODELO NO. GT52XLS (96043015903), PRODUCTO NO. 960 43 01-59  
ENSAMBLE DEL ASIENTO**

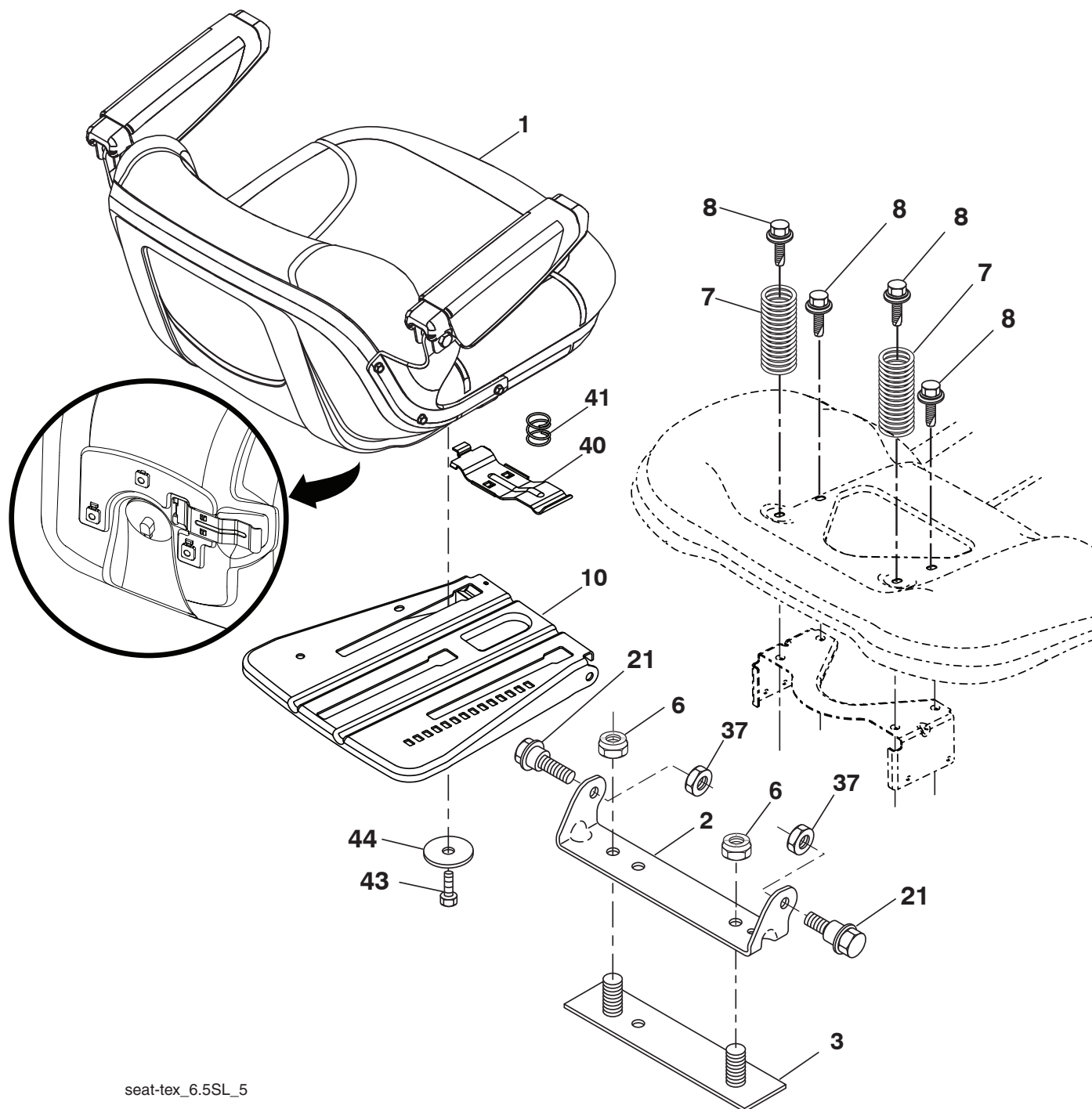

seat-tex\_6.5SL\_5

CÓDIGO No.	PIEZA No.	DESCRIPCIÓN
1	532 44 32-63	Asiento
2	532 18 01-66	Soporte pivotante del guardabarros
3	532 14 06-75	Conector del ensamble del guardabarros
6	873 80 06-00	Tuerca de presión c/aislamiento de 3/8-16 unc
7	587 61 33-01	Resorte del asiento
8	532 17 18-77	Perno de 5/16" unc x 3/4"
10	532 19 69-77	Bandeja del asiento
21	587 90 78-01	Perno de tope de 5/16-18 x 5/8

CÓDIGO No.	PIEZA No.	DESCRIPCIÓN
37	873 80 05-00	Tuerca de presión de 5/16-18 unc
40	532 43 98-71	Manija para deslizar el asiento
41	532 19 82-00	Resorte para trabar el asiento
43	874 76 06-12	Perno de cabeza hexagonal con aleta de 3/8-16 unc x 3/4
44	819 13 38-12	Arandela de 13/32 x 2-3/8 calibre 12

**NOTA:** Las dimensiones de todos los componentes están expresadas en pulgadas americanas. 1 pulgada = 25,4 mm

# TRACTOR MODELO NO. GT52XLS (96043015903), PRODUCTO NO. 960 43 01-59

## CALCOMANÍAS

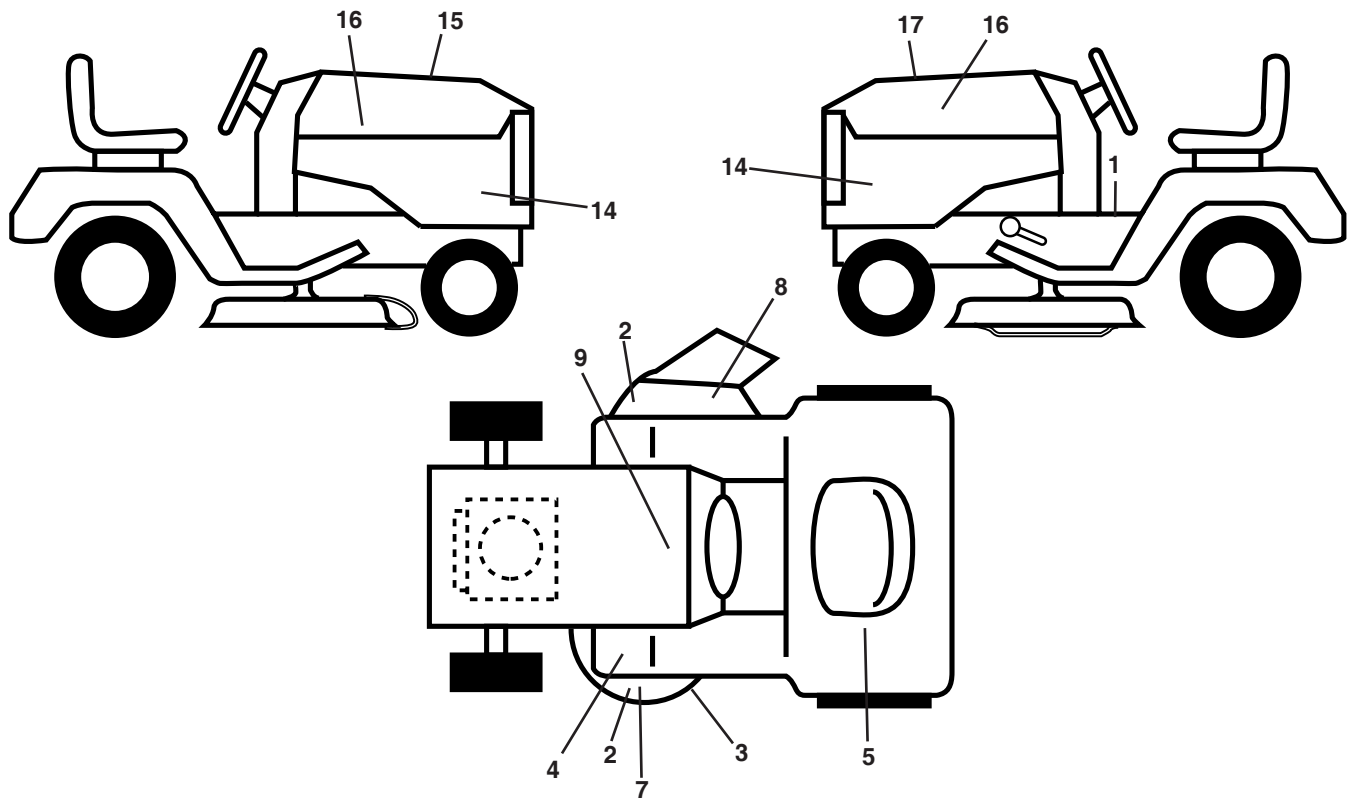

CÓDIGO No.	PIEZA No.	DESCRIPCIÓN
1	581 57 89-01	Calcomanía, Advertencia
2	581 72 43-01	Calcomanía, Ningún paso
3	581 58 00-02	Calcomanía del diagrama de la cortadora de césped
4	532 41 86-00	Calcomanía, Pedal
5	587 01 51-01	Calcomanía, Cuidado
7	532 44 81-21	Calcomanía, Cubierta
8	584 90 46-01	Calcomanía, Advertencia
9	532 14 50-05	Calcomanía de Peligro/Punto de interconexión
14	581 54 97-01	Calcomanía, Panel

CÓDIGO No.	PIEZA No.	DESCRIPCIÓN
15	532 42 38-29	Calcomanía
16	581 62 73-01	Calcomanía para la capota, logo
17	501 67 38-01	Calcomanía de reemplazo
--	581 72 48-01	Calcomanía para la desviación
--	532 43 98-82	Forro del apoyo para los pies izquierdo
--	532 43 98-81	Forro del apoyo para los pies derecho
--	115 78 89-26	Manual del operario (Inglés/Español)
--	115 78 90-27	Manual de repuestos (Inglés/Español)
--	587 71 00-26	Manual de QSG (Inglés/Español)

## WHEELS AND TIRES

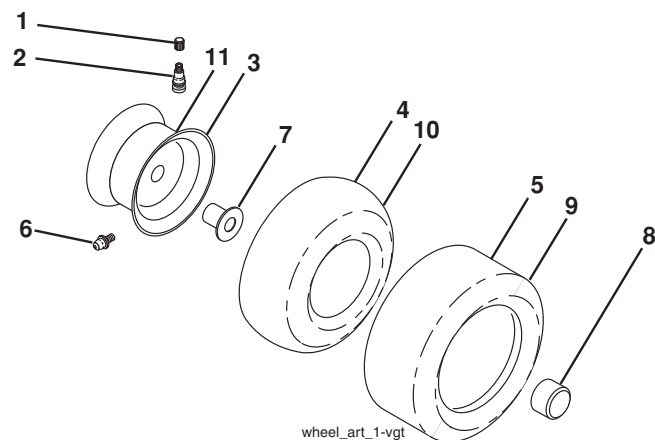

CÓDIGO No.	PIEZA No.	DESCRIPCIÓN
1	532 05 91-92	Tapa de la válvula del neumático
2	532 06 51-39	Vástago de la válvula
3	532 18 18-39	Ensamble de las llantas delanteras
4	532 00 81-34	Cámara delantera
5	532 16 10-24	Neumático delantero 16 x 6.5-8
6	532 12 49-57	Accesorio para engrasar (solo para la rueda delantera)
7	532 12 49-59	Rodamiento de la brida (solo para la rueda delantera)
8	532 17 50-39	Tapa del eje (solo para la rueda delantera)
9	532 17 04-53	Neumático trasero 23 x 10.5-12
10	532 00 71-54	Cámara trasera (Mantenimiento sólo)
11	532 14 45-10	Ensamble trasero de la llanta
--	532 14 43-34	Sellador para neumáticos (tubo de 10 onzas [283 gr])

**NOTA:** Las dimensiones de todos los componentes están expresadas en pulgadas americanas. 1 pulgada = 25,4 mm

---

# NOTES/AVISO

---

**11/19/2015 TH**