



Parts Manual

Zero Turn Mower /P-ZT 48

966 663802-02

Please read the operator manual carefully
and make sure you understand
the instructions before using the machine.



When you need spare parts or support in service questions, warranty issues, etc., please consult the following professional:

This manual belongs to the machine with the manufacturing number:	Engine	Transmission

Manufacturing Number

The machine's manufacturing number can be found on the printed plate affixed to the engine compartment.

Stated on the plate, from the top are:

- The machine's type designation (I.D.).
- The manufacturer's type number (Model).
- The machine's serial number (Serial no.)

Please have the type designation and serial number available when ordering spare parts.

CONTENTS

FRAME.....	4
ENGINE PLATE.....	6
STEERING	8
IGNITION SYSTEM.....	10
PARKING BRAKE	12
HYDRAULIC PUMP-MOTOR.....	14
HYDRAULIC FRAME	16
WHEELS & TIRES	18
MOWER LIFT / DECK LIFT.....	20
MOWER DECK / CUTTING DECK	22
BLADESHAFT	24
SEAT	26
DECALS	28
PROTECTION FRAME	30

Illustrations may or may not represent the actual assemblies and it is not recommended to use this manual as a guide to assemble or disassemble the mower.

NOTE: All fasteners are Grade 5 unless otherwise specified.

FRAME

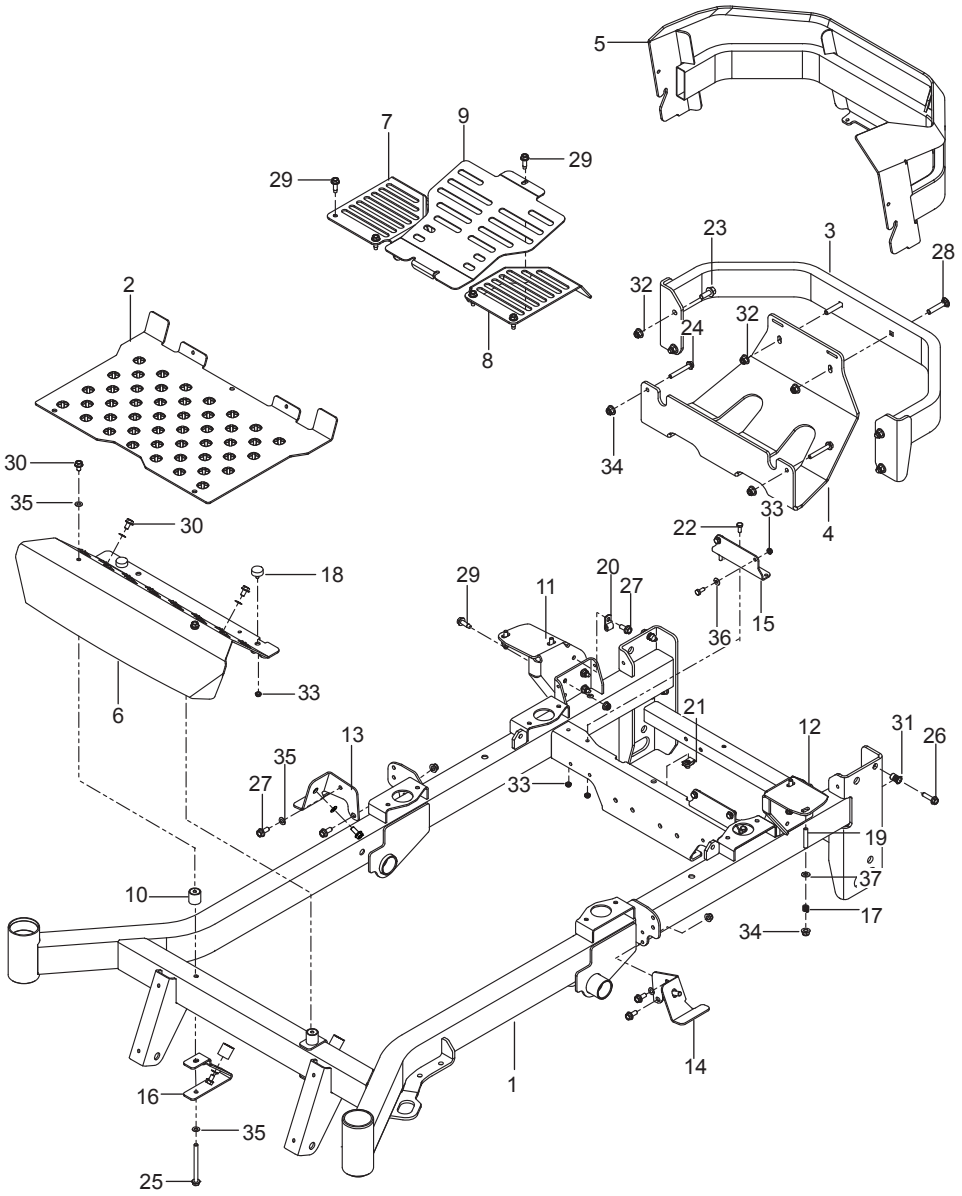

Ref.	Part No.	Qty	Description
1	574 48 28-01	1	Frame w/ Safety Decal Org
2	576 70 13-02	1	Floor Pan Org
3	522 73 89-02	1	Bumper, Rear Org
4	576 70 14-02	1	Plate, Skid Gry
5	584 85 93-02	1	Guard, Rear Gry
6	574 21 57-02	1	Footrest Org
7	576 70 15-02	1	Cover, Fan Right Blk
8	576 70 16-02	1	Cover, Fan Left Blk
9	576 70 17-02	1	Cover, Center Blk
10	510 08 32-01	4	Mount, F/F Insert
11	529 27 96-03	1	Mount, Tank Right Rear
12	529 27 97-03	1	Mount, Tank Left Rear
13	529 27 99-03	1	Mount, Tank Right Front
14	529 28 00-03	1	Mount, Tank Left Front
15	576 45 36-02	2	Mount, Tank Blk
16	510 04 03-01	2	Bracket, Rest Mount
17	539 10 28-45	4	Spring, Tank Mount
18	575 81 15-01	2	Bumper, 1/4-20 Stud 3/8"
19	539 10 25-02	4	Stud, Fuel Tank
20	539 10 98-67	1	Clamp, Double Tube
21	539 10 47-63	1	Retainer, U Type
22	874 78 04-12	8	Bolt 1/4-20 x 5/8 Hex Head
23	525 61 28-01	4	Bolt 3/8-16 x 1 Hex Flange Head
24	574 23 38-01	2	Bolt 5/16-18 x 2-1/4 Hex Flange Head
25	539 13 17-80	2	Bolt 5/16-18 x 3-3/4 Hex Flange Head
26	525 54 40-01	2	Bolt 5/16-18 x 1-1/4 Tap
27	874 49 05-12	7	Bolt 5/16-18 x 3/4 Hex Flange Head
28	539 10 01-45	2	Bolt 3/8-16 x 2 Round Head Square Neck
29	539 11 32-26	11	Bolt 5/16-18 x 1 Thread Form
30	539 99 08-58	6	Screw 5/16-18 x 1/2 Sif Tap
31	539 11 10-28	2	Nutsert 5/16-18
32	521 99 65-01	2	Nut 3/8-16 Hex Flange Nyloc
33	539 10 81-20	10	Nut 1/4-20 Hex Thin Nyloc
34	539 11 28-99	14	Nut 5/16-18 Hex Flange Nyloc
35	539 10 96-00	8	Washer 5/16 Disc Spring
36	539 99 00-55	4	Washer 1/4 Sae Flat
37	819 11 11-16	4	Washer 5/16 Sae Flat

ENGINE PLATE

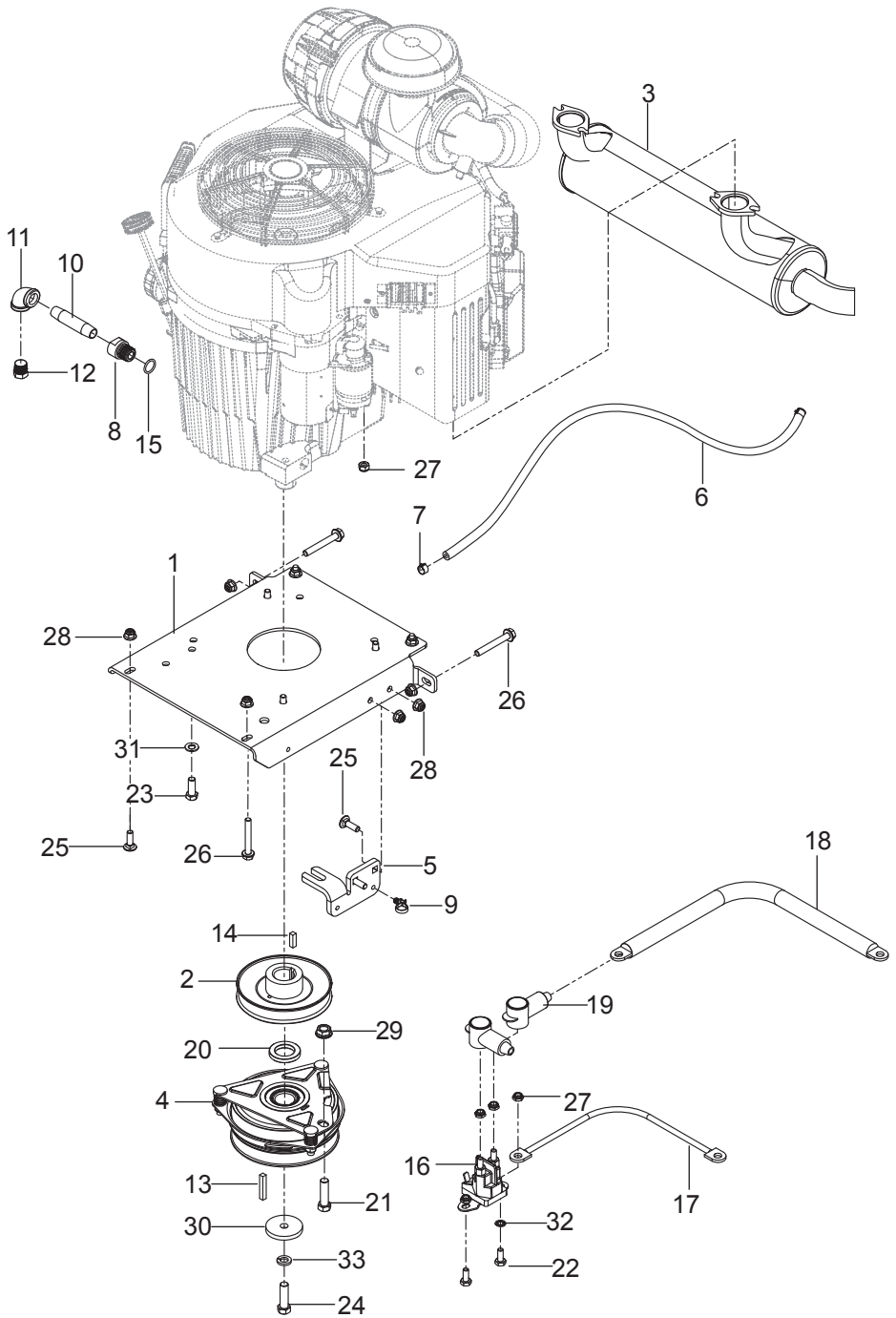

Ref.	Part No.	Qty	Description
1	510 00 46-02	1	Plate, Engine Blk
2	510 01 98-01	1	Pulley, Engine
3	525 75 02-01	1	Muffler
4	539 11 34-37	1	Clutch, Gt 3.5
5	522 67 67-02	1	Stop, Clutch
6	539 10 55-26	1	Fuel Line 18"
7	539 91 22-22	2	Clamp
8	539 11 96-80	1	Adaptor, Oil Drain
9	505 28 00-01	1	Tie Wrap w/ Clip
10	539 11 89-11	1	Pipe 3/8 Npt x 3"
11	539 10 50-72	1	Elbow 90°
12	522 83 70-01	1	Plug 3/8 NPTF Drain
13	539 91 02-10	1	Key 1/4 Sq x 2
14	539 10 53-08	1	Key 1/4 Sq x 1
15	539 10 96-18	1	O-Ring
16	539 10 17-14	1	Solenoid
17	539 10 54-09	1	Ground Wire
18	539 10 27-57	1	Cable, Positive
19	539 10 27-59	2	Insulator
20	525 31 39-01	1	Spacer
21	539 10 48-67	1	Bolt 7/16-14 x 1-1/4 Hex Head
22	539 99 00-72	2	Bolt 1/4-20 x 5/8 Hex Head
23	539 99 05-63	4	Bolt 3/8-16 x 1 Hex Head
24	539 10 01-41	1	Bolt 7/16-20 x 1-1/2 Hex Head
25	539 99 02-08	4	Bolt 5/16-18 x 1 Round Head Square Neck
26	574 23 38-01	3	Bolt 5/16-18 x 2-1/4 Hex Flange
27	539 10 81-20	5	Nut 1/4-20 Hex Thin Nyloc
28	539 11 28-99	8	Nut 5/16-18 Hex Flange Nyloc
29	539 10 25-82	1	Nut 7/16-14 Hex Whiz Lock
30	539 12 56-26	1	Washer, Blade
31	539 10 25-93	4	Washer 3/8 Spring
32	539 99 00-53	1	Washer 1/4 Internal Tooth Lock
33	539 99 02-47	1	Washer 7/16 Slotted Lock
	NOT SHOWN		
	25 55 42-01	1	Engine Harness, Kaw
	574 82 58-01	1	Kit, Spark Arrestor
	586 83 97-01	2	Gasket, Exhaust
	-----	1	Engine, Kawasaki FX691V 22 Hp For Engine Replacement Parts, See a Kawasaki Dealer

STEERING

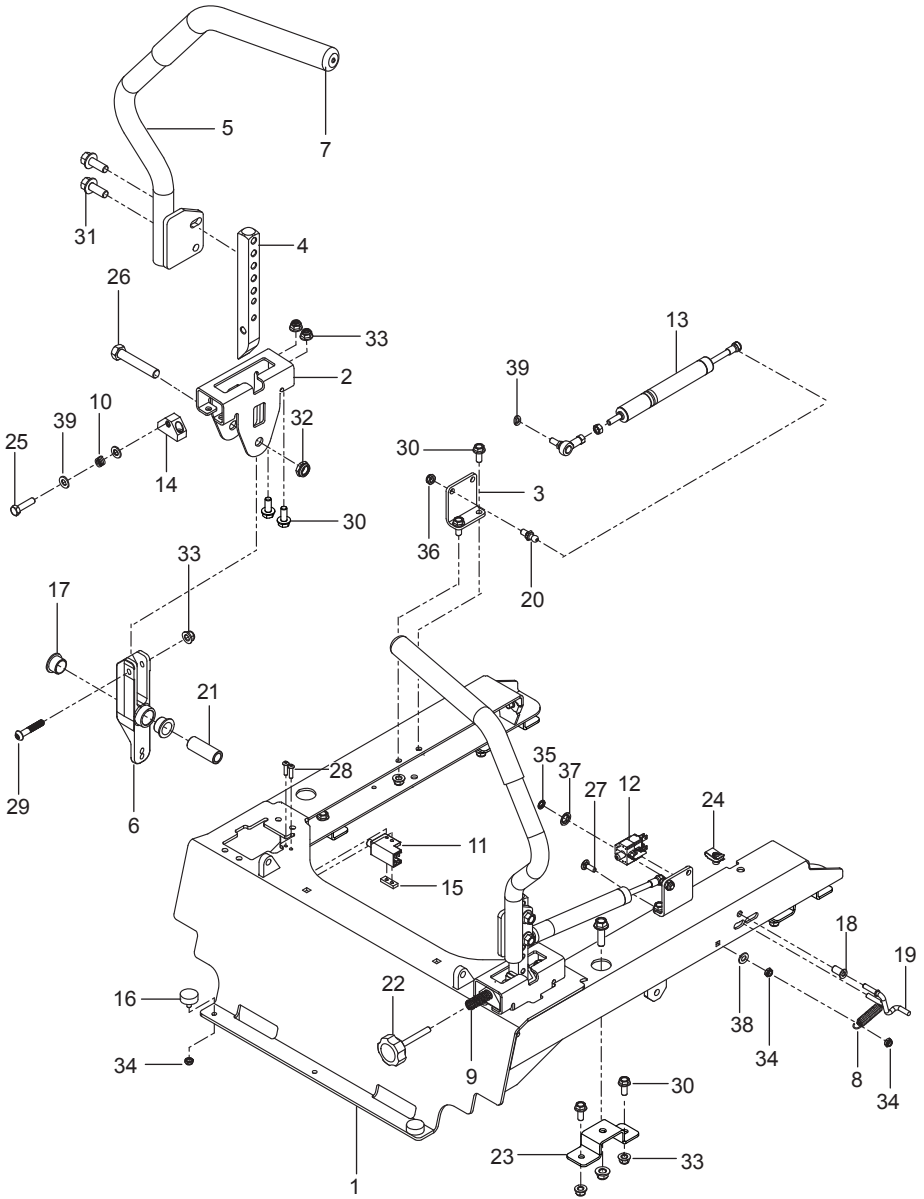

Ref.	Part No.	Qty	Description
1	577 32 77-02	1	Frame, Seat Mount Org
2	586 73 72-02	2	Bracket, Control
3	577 26 58-01	2	Bracket, Dampener
4	574 26 94-01	2	Lever, Motion
5	577 04 24-03	1	Lever, w/ Grip, Right
	577 04 23-03	1	Lever, w/ Grip, Left
6	576 14 03-02	2	Lever, Control
7	539 13 08-94	2	Grip, Lever
8	539 02 00-35	1	Spring
9	576 85 03-01	1	Spring
10	539 10 28-45	1	Spring
11	539 10 95 53	2	Switch N.c.
12	539 11 37-92	1	Switch, Brake (3-Pole)
13	516 02 03-01	2	Assembly, Dampener
14	581 43 75-01	2	Block, Tracking
15	539 13 15-19	2	Plate, Tapped
16	575 81 15-01	2	Bumper
17	539 13 15-18	4	Bearing, Flanged
18	511 59 49-01	1	Bushing 1/4 Flange
19	511 59 50-01	1	Link, Switch
20	539 11 06-07	2	Ball Stud 10Mm
21	577 25 24-01	2	Spacer, Pivot
22	539 13 17-99	1	Knob
23	522 84 97-02	4	Mount, Blk
24	539 10 47-63	4	Retainer, U Type
25	874 78 05-20	1	Bolt 5/16-18 x 1-1/4 Hex Head Tap
26	874 78-08 44	2	Bolt 1/2-13 x 2-3/4 Hex Head
27	872 11 04-06	1	Bolt 1/4-20 x 3/4 Round Head Square Neck Gr 2
28	574 82 27-01	4	Screw 10-24 x 3/4 Socket Head
29	576 85 04-02	2	Screw 5/16-18 x 1-3/4 Button Head
30	874 49 05-12	20	Bolt 5/16-18 x 3/4 Hex Flange Head
31	525 61 28-01	4	Bolt 3/8-16 x 1 Hex Flange Head
32	539 10 80-10	2	Nut 1/2-13 Hex Jam Nyloc Gr 2
33	539 11 28-99	20	Nut 5/16-18 Hex Flange Nyloc
34	539 10 81-20	4	Nut 1/4-20 Hex Thin Nyloc
35	539 10 22-34	1	Nut 1/4 Push
36	873 80 05-00	2	Nut 5/16-18 Hex Nyloc
37	539 91 38-47	2	Nut 3/8 Retainer
38	819 11 11-16	3	Washer 5/16 Sae Flat
39	810 03 05-00	2	Washer 5/16 Slotted Lock

IGNITION SYSTEM

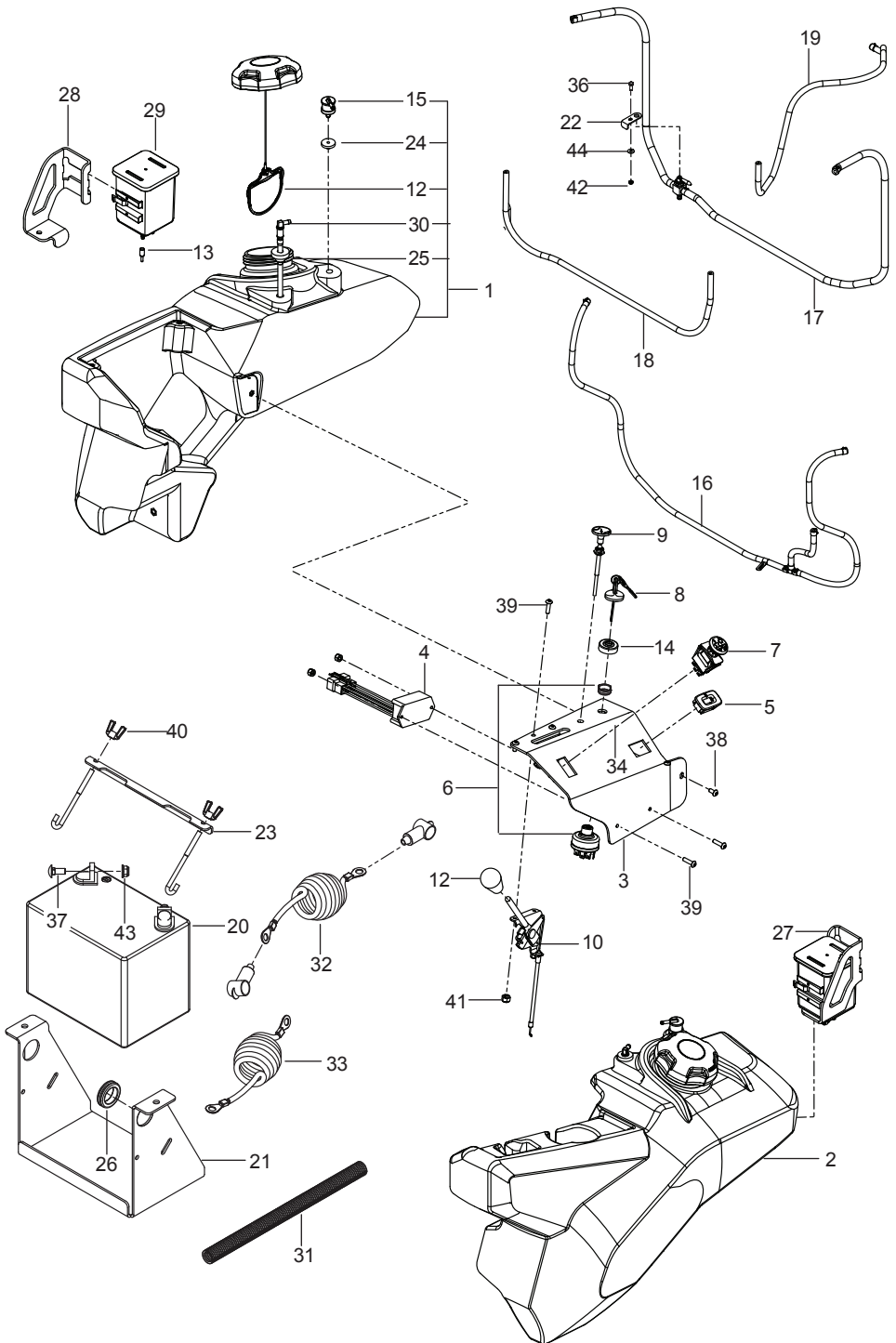

Ref.	Part No.	Qty	Description
1	584 28 04-01	1	Assy, Tank Rt Gry
2	584 28 03-01	1	Assy, Tank Lt Gry
3	529 28 02-02	1	Panel, Control
4	574 51 40-01	1	Timer, Seat
5	586 16 18-01	1	Meter, Service
6	574 45 54-01	1	Switch, Ignition
7	539 13 16-27	1	Switch, PTO 10 Amp
8	574 45 55-01	1	Key, Ignition
9	574 20 69-01	1	Cable, Choke
10	574 20 70-01	1	Cable, Throttle
11	539 13 26-24	1	Knob
12	575 01 81-01	2	Cap w/ Tether, Fuel
13	576 97 87-01	1	Cap, Vinyl
14	539 10 31-78	1	Cap, Ignition Switch
15	576 61 81-01	2	Valve, Fuel Check
16	576 97 90-01	1	Assy, Vapor Line
17	577 15 05-01	1	Assy, Fuel Line
18	587 04 45-30	1	Hose 3/16 x 30"
19	587 04 45-33	1	Hose 3/16 x 33"
20	539 10 24-36	1	Battery
21	510 02 99-02	1	Bracket, Battery Blk
22	577 10 40-02	1	Bracket, Valve
23	510 03 00-01	1	Bracket, Battery Mount
24	576 61 82-01	2	Grommet, Check Valve
25	539 10 52-45	2	Grommet, Rubber
26	539 10 59-74	1	Grommet
27	576 92 70-01	1	Mount, Canister Rt
28	576 92 69-01	1	Mount, Canister Lt
29	532 41 41-14	2	Canister, Carbon
30	525 86 54-01	2	Fitting, Fuel
31	574 23 53-01	1	Loom 5/8 Split
32	522 71 87-01	1	Cable, Positive
33	522 71 07-01	1	Cable, Negative
34	539 10 27-59	2	Insulator
35	510 06 40-01	2	J Hook
36	539 99 05-80	1	Bolt 1/4-20 x 3/4 Hex Head
37	872 14 05-06	2	Bolt 5/16-18 x 3/4 Round Head Square Neck
38	539 11 43-41	3	Screw 10-24 x 3/8 Socket Head
39	574 82 27-01	4	Screw 10-24 x 3/4 Socket Head
40	539 99 09-97	2	Wingnut 1/4-20 Nyloc
41	539 97 69-77	4	Nut 10-24 Hex Nyloc
42	539 10 81-20	1	Nut 1/4-20 Hex Thin Nyloc
43	539 11 28-99	2	Nut 5/16-18 Hex Flange Nyloc
44	539 99 05-98	1	Washer 1/4 Flat
	NOT SHOWN		
	510 09 36-01	1	Harness, Wiring

Ref.	Part No.	Qty	Description
1	576 41 63-01	1	Shaft, Brake
2	576 41 64-01	1	Arm, Right Brake
3	515 98 00-02	1	Lever, Brake
4	539 97 65-26	1	Grip, Lever
5	515 98 03-01	1	Link, Follower
6	576 76 40-01	2	Spacer, Shaft
7	539 13 15-18	2	Bearing, Flange
8	539 97 64-81	2	Yoke
9	522 70 59-01	2	Pin 3/8 Clevis Spring
10	576 45 95-01	2	Linkage, Brake
11	575 22 98-02	2	Bracket, Brake
12	575 23 03-01	1	Spring
13	539 13 21-61	6	Bushing, Brake
14	539 11 06-31	1	Roll Pin 5/16" Dia.
15	539 11 03-03	2	Bolt 5/16 Shoulder
16	539 10 04-13	3	Bolt 3/8-16 x 1-1/4 Round Head Square Neck
17	539 92 34-63	1	Bolt 3/8-16 x 3-1/4
18	539 20 02-82	3	Nut 3/8-16 Hex Jam Nyloc
19	539 11 09-43	2	Nut 5/16-24 Hex Nyloc
20	539 99 02-23	2	Nut 5/16-24 Hex
21	539 11 56-17	2	Nut 5/16-18 Hex Nyloc
22	539 13 30-07	2	Washer, Wave
23	525 49 09-01	2	Washer, Friction
24	539 91 20-63	1	Washer, Cone

HYDRAULIC PUMP-MOTOR

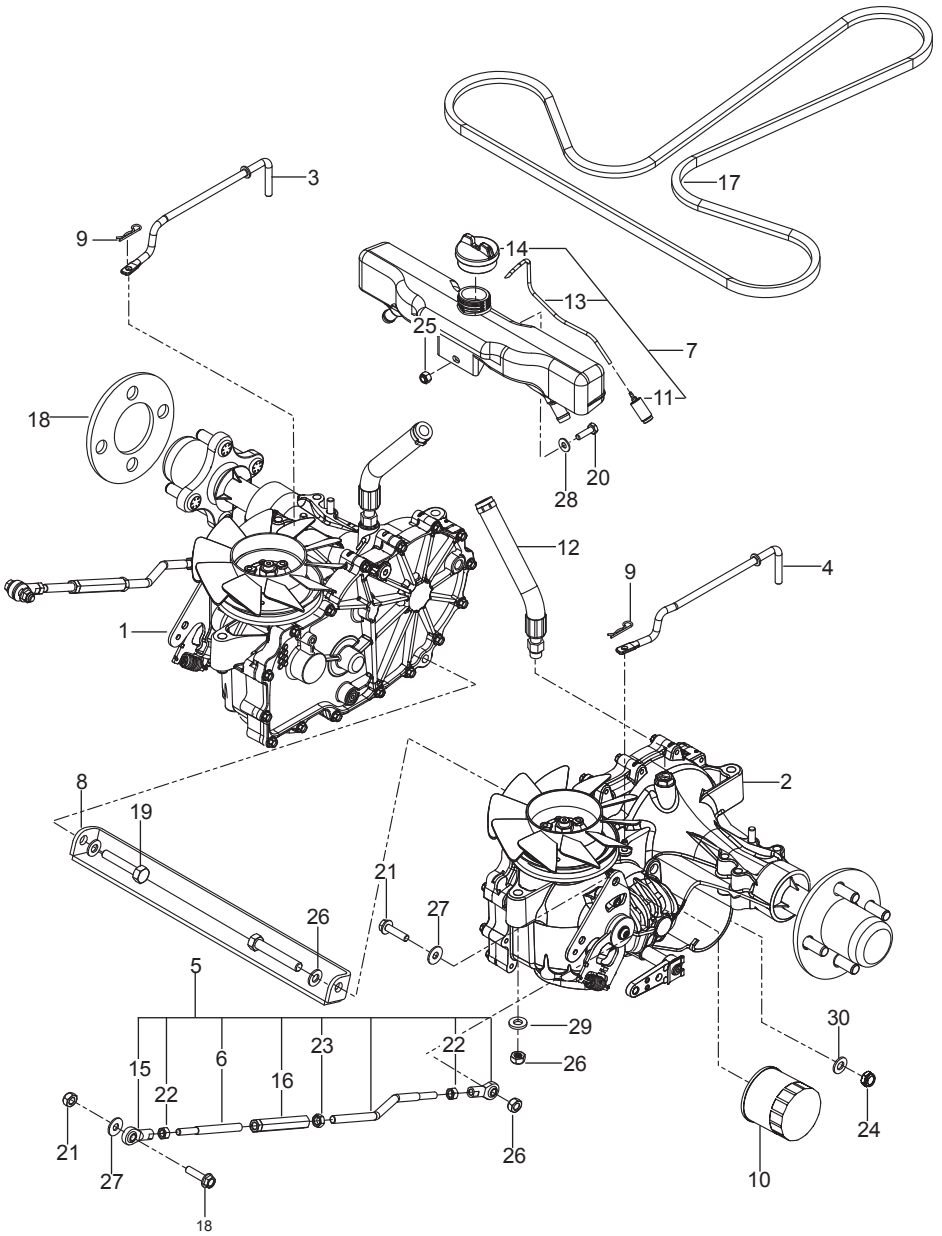

Ref.	Part No.	Qty	Description
1	574 56 91-02	1	Trans, Zt-3400, Right
2	574 56 91-01	1	Trans, Zt-3400, Left
3	539 13 16-18	1	Linkage, Right Bypass
4	539 13 16-16	1	Linkage, Left Bypass
5	576 41 57-01	2	Assembly, Linkage, Control
6	522 55 92-01	2	Linkage, Control Ft
7	585 31 82-01	1	Assy, Expansion Tank
8	851 82 02-02	1	Bracket
9	539 97 69-88	2	Hairpin Cotter
10	539 11 34-66	2	Filter, Hydro
11	530 09 56-46	1	Filter
12	574 89 21-01	2	Hose, Expansion
13	586 06 75-01	1	Hose, Fuel Line
14	586 07 27-01	1	Cap, Tank
15	539 10 25-90	4	Ball End, Right
16	539 10 91-49	2	Turnbuckle 3/8
17	576 66 72-01	1	Belt
18	580 90-62-02	2	Spacer, Wheel
19	539 10 85-51	2	Bolt 3/8-16 x 2-1/4 Gr 8 Hex Head
20	539 99 06-42	1	Bolt 1/4-20 x 7/8 Hex Head
21	525 54 40-01	4	Bolt 5/16-18 x 1-1/4 Tap
22	539 99 02-23	4	Nut 5/16-24 Hex
23	539 10 87-32	2	Nut 3/8-24 Hex Jam
24	581 84 81-01	2	Nut 3/8-16 Lock Gr C
25	539 97 69-78	1	Nut 1/4-20 Hex Nyloc
26	585 47 68-01	4	Nut 5/16-18 Hex Lock
27	539 99 06-92	4	Washer 5/16 Std Flat
28	539 99 00-55	1	Washer 1/4 Sae Flat
29	585 47 70-01	2	Washer 5/16 Sae Flat
30	539 99 01-22	4	Washer 3/8 Sae Flat

HYDRAULIC FRAME

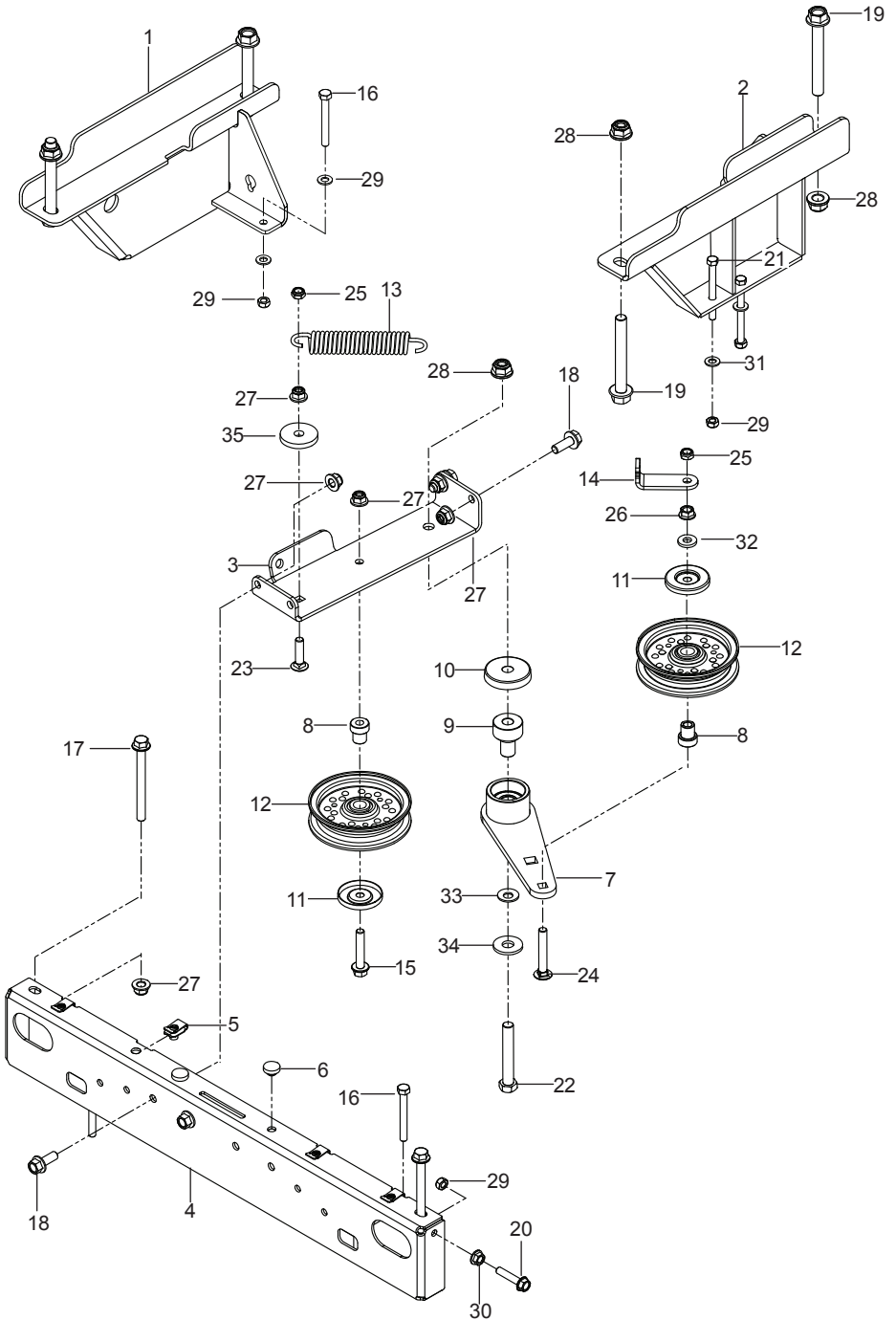

Ref.	Part No.	Qty	Description
1	581 82 13-02	1	Mount, Trans Right Blk
2	581 82 12-02	1	Mount, Trans Left Blk
3	576 45 99-02	1	Mount, Idler Blk
4	581 81 30-02	1	Mount, Ft Blk
5	539 10 47-63	4	Retainer, U Type
6	539 10 25-87	2	Grommet, Bumper
7	510 04 16-03	1	Arm, Idler w/ Bearings
8	525 43 56-01	2	Pivot, Idler
9	510 20 63-01	1	Pivot, Bearing
10	539 11 46-62	1	Shield, Dust
11	510 25 45-01	2	Shield, Dust
12	539 97 66-88	2	Pulley, Idler
13	575 47 09-01	1	Spring, Extension
14	576 45 98-01	1	Bracket, Spring
15	874 49 06-32	1	Bolt 3/8-16 x 2
16	585 47 66-01	4	Bolt 5/16-18 x 2-1/2 Hex Flange
17	521 99 66-01	2	Bolt 3/8-16 x 4
18	525 61 28-01	4	Bolt 3/8-16 x 1
19	525 54 48-01	4	Bolt 1/2-13 x 4 Gr 8
20	525 46 54-01	4	Bolt 5/16-18 x 1-1/2
21	585 47 67-01	4	Bolt Hex Head 5/16-18 x 3
22	539 10 34-33	1	Bolt Hex Head 1/2-13 x 3-1/4
23	539 10 93-45	1	Bolt Round Head Square Neck 3/8-16 x 1-1/2
24	539 12 81-01	1	Bolt 3/8-16 x 2-1/2 Carriage
25	539 20 02-82	2	Nut 3/8-16 Hex Jam Nyloc
26	539 99 06-13	1	Nut 3/8-16 Hex Whiz Lock
27	521 99 65-01	8	Nut 3/8-16 Hex Flange Nyloc
28	521 99 11-01	5	Nut 1/2-13 Hex Flange Nyloc
29	585 47 68-01	5	Nut 5/16-18 Hex Lock
30	539 99 05-85	1	Nut 5/16-18 Hex Whiz Lock
31	585 47 70-01	3	Washer 5/16 Sae Flat
32	522 02 34-01	1	Washer 3/8 Thick
33	539 11 55-28	1	Washer 1/2 Belleville
34	539 10 95-54	1	Washer 1/2 Flat
35	539 10 65-04	1	Washer, Heavy

WHEELS & TIRES

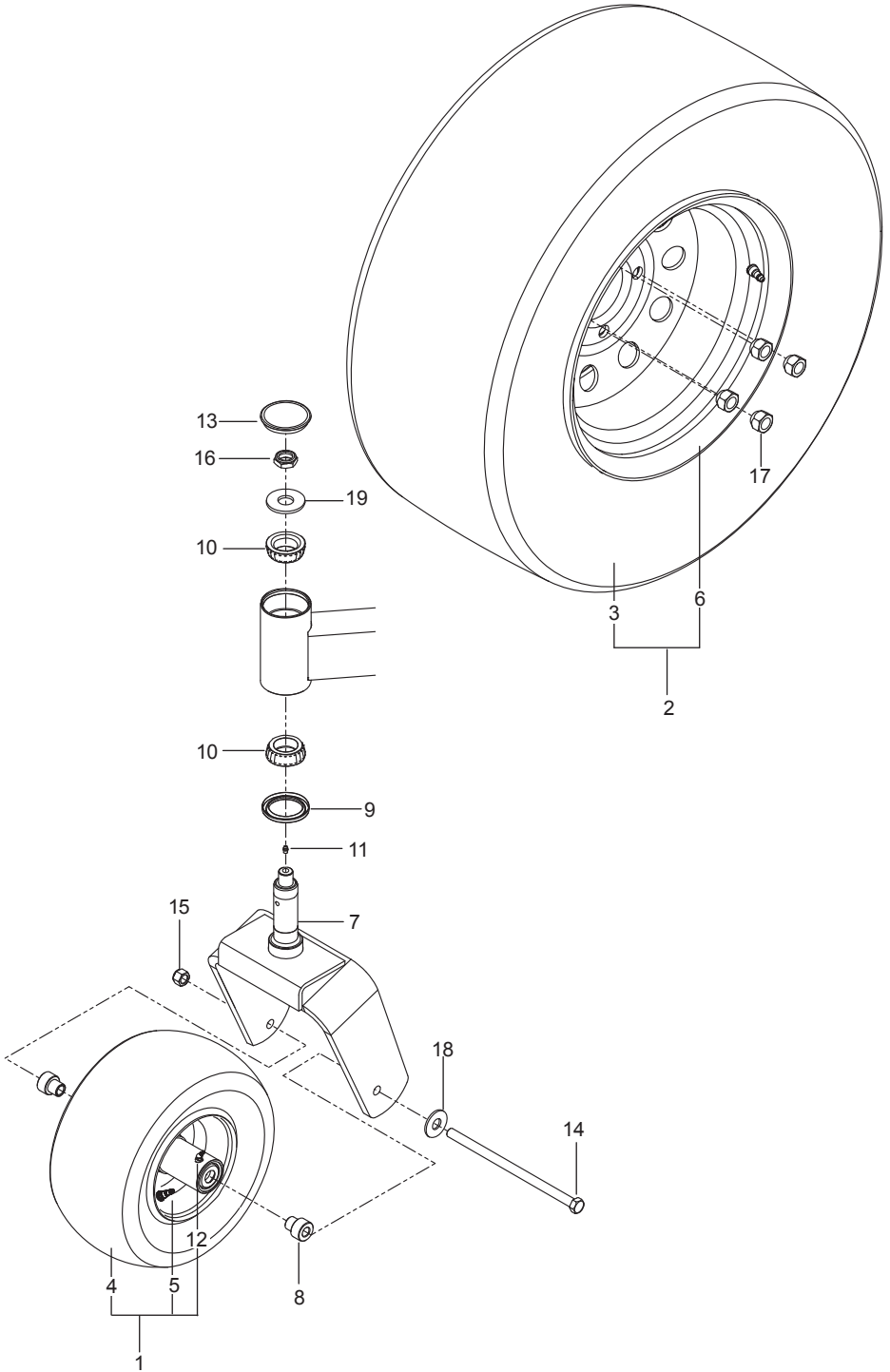

Ref.	Part No.	Qty	Description
1	539 10 55-21	2	Assembly, Tire 13 x 6.5
2	522 90 51-01	2	Assembly, Tire 23 x 10.5
3	539 10 74-31	2	Tire 23 x 10.5 Turf Master
4	539 10 55-22	2	Tire
5	539 10 55-23	2	Rim
6	522 90 51-02	2	Rim
7	525 61 19-02	2	Yoke, Caster, Org
8	539 10 55-18	4	Spacer, Axle
9	510 03 43-01	2	Seal, Bearing
10	510 03 44-03	4	Cone
11	539 10 14-74	2	Zerk
12	539 10 33-00	2	Zerk 1/4 -28 Angled
13	510 03 40-01	2	Cap, Dust
14	539 10 55-17	2	Bolt 1/2-13 x 9-1/2 Hex Nyloc
15	521 99 11-01	2	Nut 1/2-13 Hex Flange Nyloc
16	522 84 26-01	2	Nut 3/4-16 Hex Thin Nyloc
17	539 10 11-73	8	Nut, Lug
18	539 99 02-50	2	Washer 1/2 Sae
19	574 82 47-01	2	Washer 3/4 Hardened

MOWER LIFT / DECK LIFT

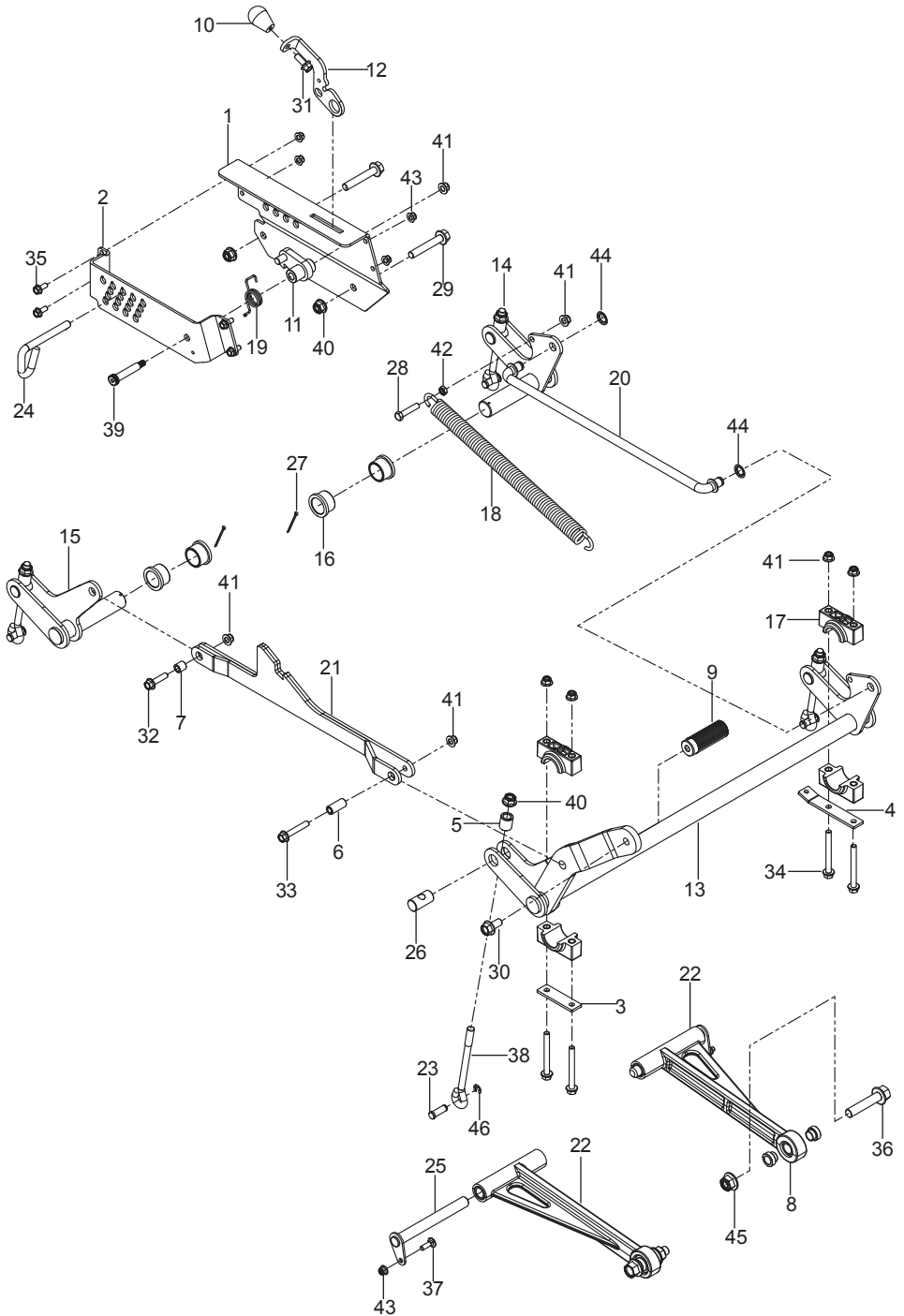

Ref.	Part No.	Qty	Description
1	576 48 00-02	1	Plate, Height, Inner Org
2	576 48 01-02	1	Plate, Height, Outer Org
3	525 82 22-01	1	Plate, Pillow Block
4	576 64 67-01	1	Plate, Spring Anchor
5	576 48 58-01	4	Spacer, Eyebolt
6	576 62 31-01	1	Spacer, Front Lift Strap
7	576 62 30-01	1	Spacer, Rear Lift Strap
8	510 36 25-01	4	Spacer, Strut
9	510 40 83-01	1	Pedal, Deck Height
10	539 13 26-24	1	Knob
11	510 40 68-01	1	Latch, Transport
12	576 63 89-01	1	Lever, Release
13	576 47 92-01	1	Shaft, Deck Lift Front
14	576 47 99-01	1	Shaft, Lift Left Rear
15	576 47 94-01	1	Shaft, Lift Right Rear
16	510 08 94-01	4	Bushing, Flanged
17	510 02 39-02	4	Block, Pillow
18	576 67 66-01	1	Spring, Extension
19	510 37 66-01	1	Spring, Torsion
20	510 08 98-01	1	Rod, Lift
21	576 62 26-01	1	Strap, Deck
22	510 10 65-01	2	Assembly, Strut
23	510 09 01-01	4	Pin 7/16 Clevis
24	510 01 65-01	1	Pin, Height
25	515 98 82-01	2	Pin, Strut
26	576 48 56-01	4	Pin, Trunion
27	539 10 28-89	2	Pin 1/8 x 2 Cotter
28	539 99 07-30	1	Bolt 3/8-16 x 1-3/4 Hex Head
29	874 49 08-48	2	Bolt 1/2-13 x 3 Hex Flange Head
30	574 21 06-01	1	Bolt 1/2-13 x 1 Hex Flange Head
31	525 61 28-01	1	Bolt 3/8-16 x 1 Hex Flange Head
32	576 62 16-01	1	Bolt 3/8-16 x 1-1/2 Hex Flange Head
33	874 49 06-36	1	Bolt 3/8-16 x 2-1/4 Hex Flange Head
34	874 49 06-52	4	Bolt 3/8-16 x 3-1/2 Hex Flange Head
35	874 49 05-12	4	Bolt 5/16-18 x 3/4 Hex Flange Head
36	874 45 10-48	2	Bolt 5/8-11 x 3 Hex Flange Head Gr 8
37	539 99 02-08	2	Bolt 5/16-18 x 1 Round Head Square Neck
38	576 47 90-01	4	Eyebolt, Deck Lift
39	516 03 55-01	1	Bolt 3/8-16 x 2-1/4 Shoulder
40	521 99 11-01	6	Nut 1/2-13 Hex Flange Nyloc
41	521 99 65-01	8	Nut 3/8-16 Hex Flange Nyloc
42	539 10 93-32	1	Nut 3/8-16 Hex Jam
43	539 11 28-99	6	Nut 5/16-18 Hex Flange Nyloc
44	539 10 93-04	2	Nut 5/8 Push
45	525 82 91-01	2	Nut 5/8-11 Flange Nyloc
46	522 70 52-01	4	E Ring 7/16

MOWER DECK / CUTTING DECK

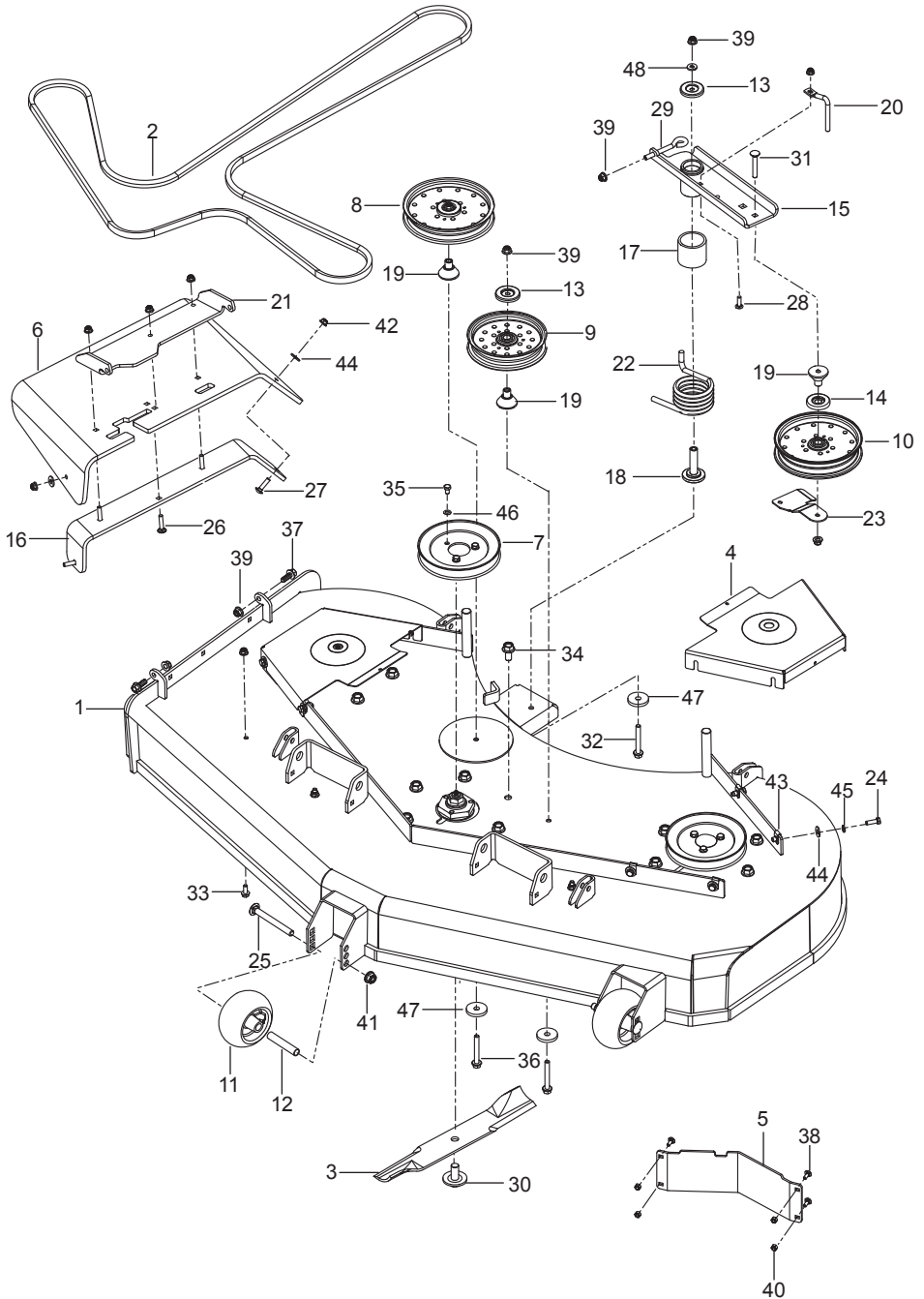

Ref.	Part No.	Qty	Description
1	588 12 76-06	1	Deck w/ Safety Decals
2	575 65 84-06	1	Belt
3	581 05 55-01	3	Blade
4	510 13 12-02	2	Shield, Belt
5	510 43 75-02	1	Baffle, Diverter Left
6	525 48 58-01	1	Chute, Discharge
7	539 13 06-45	3	Pulley
8	525 59 82-01	1	Pulley, Idler 7" Narrow
9	510 01 96-01	1	Puller, Idler 6" Narrow
10	510 01 51-01	1	Pulley, Idler 7"
11	574 16 96-01	2	Roller, Gauge
12	574 19 64-01	2	Tube Roller Axle
13	510 25 45-01	3	Shield, Dust
14	510 26 22-01	1	Shield, Dust
15	525 46 44-03	1	Arm, Idler w/ Spacer, Bearings
16	525 48 60-02	1	Support, Bracket Blk
17	525 46 56-01	1	Spacer, Idler Pivot
18	522 72 97-01	1	Bearing, Idler Pivot
19	510 26 37-01	3	Bearing, Idler Arm
20	574 26 22-01	1	Belt Keeper
21	574 19 70-02	1	Bracket, Chute Pivot Blk
22	525 31 09-01	1	Spring, Torsion, Idler
23	574 26 21-02	1	Belt Guide, Blk
24	874 78 05-16	8	Screw 5/16-18 x 1 Hex
25	510 02 23-01	2	Bolt 1/2-13 x 4-3/4 Round Head Square Neck
26	539 10 29-33	3	Bolt 5/16-18 x 1-1/2 Round Head Square Neck
27	539 10 04-72	2	Bolt 5/16-18 x 1-1/4 Round Head Square Neck
28	872 11 05-08	1	Bolt 5/16-18 x 1 Round Head Square Neck
29	574 20 20-01	1	Eye Bolt
30	539 11 90-07	3	Blade Bolt
31	539 12 81-01	1	Bolt 3/8-16 x 2-1/2 Carriage
32	874 88 06-72	1	Bolt 3/8-16 x 4-1/2 Hex Head
33	874 49 05-12	4	Bolt 5/16-18 x 3/4 Hex Flange Head
34	574 21 06-01	18	Bolt 1/2-13 x 1 Hex Flange Head
35	539 13 03-15	9	Bolt 5/16-18 x 1/2 Hex Head
36	874 49 06-44	2	Bolt 3/8-16 x 2-3/4 Hex Flange Head
37	525 61 28-01	2	Bolt Washer Head 3/8-16 x 1
38	539 11 56-20	4	Bolt 1/4-20 x 3/4 Carriage
39	521 99 65-01	5	Nut 3/8-16 Hex Flange Nyloc
40	539 97 69-78	4	Nut 1/4-20 Hex Nyloc
41	521 99 11-01	2	Nut 1/2-13 Hex Flange Nyloc
42	539 11 28-99	9	Nut 5/16-18 Hex Flange Nyloc
43	539 10 47-63	8	Retainer, U Type
44	819 12 14-14	10	Washer 5/16 Std Flat
45	810 03 05-00	8	Washer 5/16 Slotted Lock
46	539 10 96-00	9	Washer 5/16 Disc Spring
47	539 10 65-04	3	Washer, Heavy
48	522 02 34-01	1	Washer 3/8 Thick

BLADESHAFT

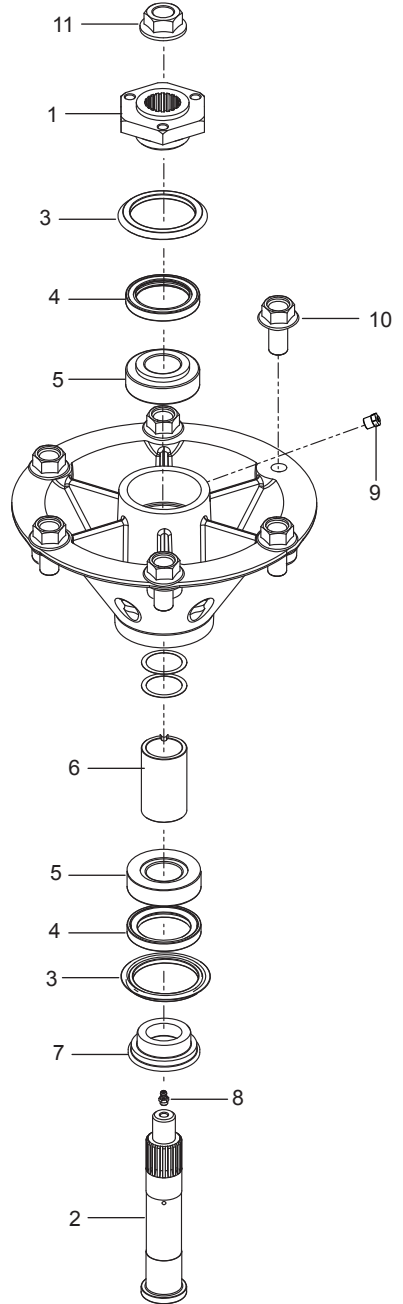
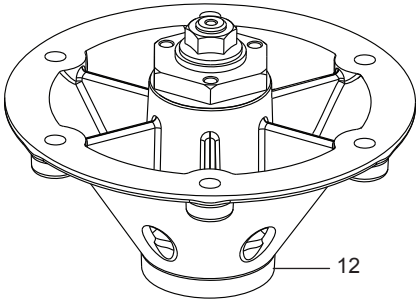

Ref.	Part No.	Qty	Description
1	580 94 22-01	3	Hub
2	580 94 21-01	3	Shaft, Spindle
3	580 94 27-01	3	Seal, V Ring
4	580 94 26-01	6	Seal, Shaft
5	580 94 18-01	6	Bearing, Tapered
6	580 94 23-01	3	Spacer
7	580 94 25-01	3	Carrier, Seal
8	539 97 69-98	3	Zerk
9	539 97 73-26	3	Valve, Grease Poppet
10	574 21 06-01	18	Bolt 1/2-13 X 1 Hex Flange Head
11	539 13 06-53	3	Nut 3/4-16 Hex Flange
12	580 94 33-03	3	Assembly, Spindle
	NOT SHOWN		
	574 75 42-01	1	Kit, Bearing Assembly

When replacing the Spindle bearings,
order the Bearing Assembly Kit to
assure proper installation

SEAT

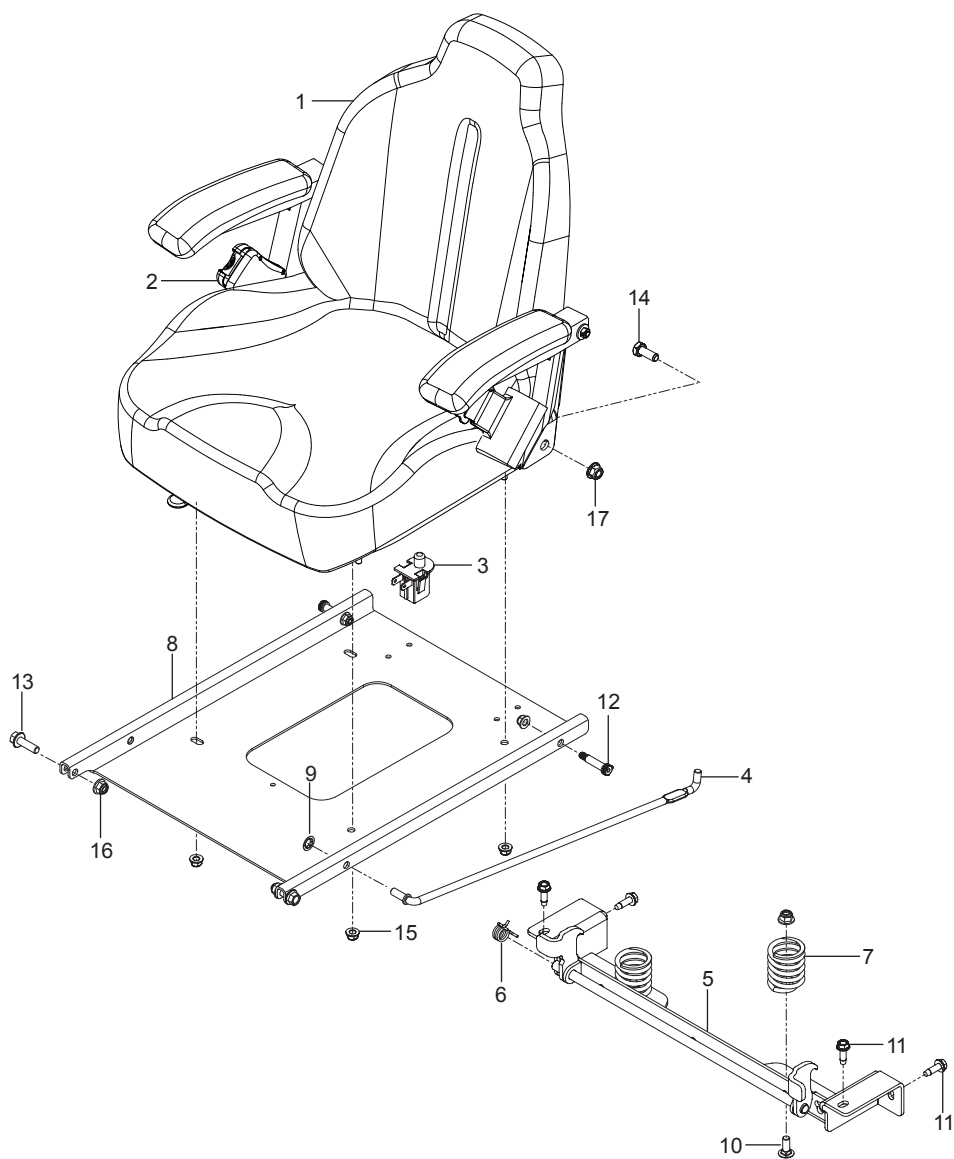

Ref.	Part No.	Qty	Description
1	501 58 04-01	1	Assembly, Seat
2	576 78 34-01	1	Assembly, Seat Belt
3	539 11 97-41	1	Switch, Seat
4	510 06 41-01	1	Rod, Seat
5	585 85 74-02	1	Latch, Seat
6	520 28 31-01	1	Spring, Torsion
7	539 11 03-00	2	Spring, Seat
8	510 03 93-02	1	Pan, Seat
9	539 91 38-47	2	Retainer 3/8 Nut
10	539 99 06-45	2	Bolt 3/8-16 x 1 Round Head Square Neck
11	539 11 32-26	4	Bolt 5/16-18 x 1 Thread Form
12	515 99 06-01	2	Bolt 3/8 x 1-1/4 5/16-18 Shoulder
13	525 83 42-01	2	Bolt 3/8-16 x 1-1/4 Hex Flange Head
14	539 10 01-43	2	Bolt 7/16-14 x 1 Hex Head
15	539 11 28-99	6	Nut 5/16-18 Hex Flange Nyloc
16	521 99 65-01	2	Nut 3/8-16 Hex Flange Nyloc
17	539 13 20-19	2	Nut 7/16-14 Whiz Lock

DECALS

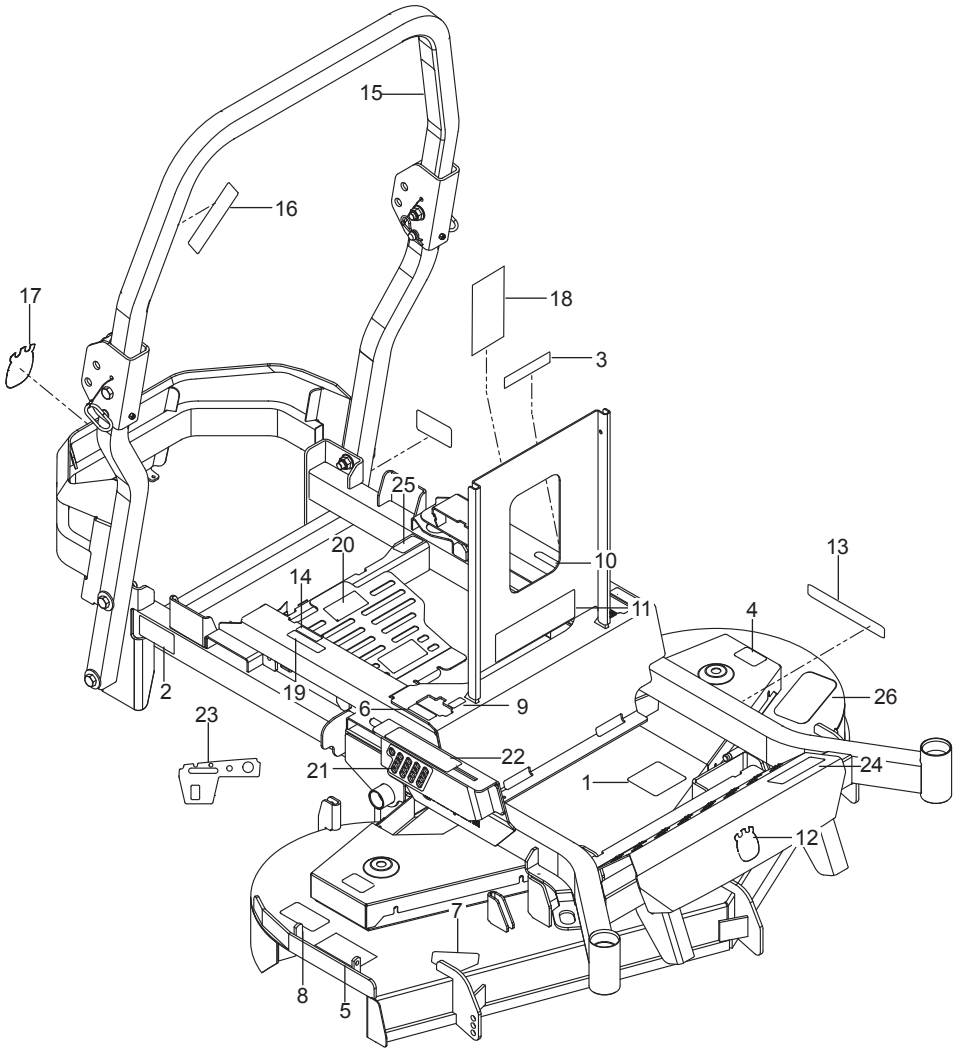

Ref.	Part No.	Qty	Description
1	574 43 73-01	1	Decal, Belt Route
2	539 10 57-44	1	Decal, Belt Drive Warning
3	539 10 57-45	1	Decal, Battery Warning
4	581 72 43-01	2	Decal, No Step
5	539 10 57-46	1	Decal, Severing
6	589 28 30-01	2	Decal, Motion Control
7	584 90 46-01	1	Decal, Blade Warning
8	581 72 44-01	1	Decal, Deflector
9	585 14 26-01	2	Decal, Tracking
10	585 14 88-01	1	Decal, Park Brake
11	583 93 40-01	1	Decal, Warning
12	532 42 86-76	1	Decal, Crown H Small
13	532 42 91-96	2	Decal, Husqvarna
14	574 56 94-01	1	Decal, Fuse
15	574 56 90-06	1	Decal, ROPS
16	574 56 90-02	1	Decal, ROPS Warning
17	574 45 50-01	1	Decal, Crown Large
18	585 38 49-01	1	Decal, Service
19	532 42 41-02	1	Decal, Spark Arrestor
20	539 10 18-81	1	Decal, Exhaust Warning
21	576 75 53 01	1	Decal, Height
22	576 76 38-01	1	Decal, Release Lever
23	510 24 66-02	1	Decal, Console
24	576 75 52 07	1	Decal, P-ZT54
25	577 15 01-01	1	Decal, Fuel
26	539 10 18-81	1	Decal, Exhaust Warning
27	539 12 13-22	1	Foot Pad

PROTECTION FRAME

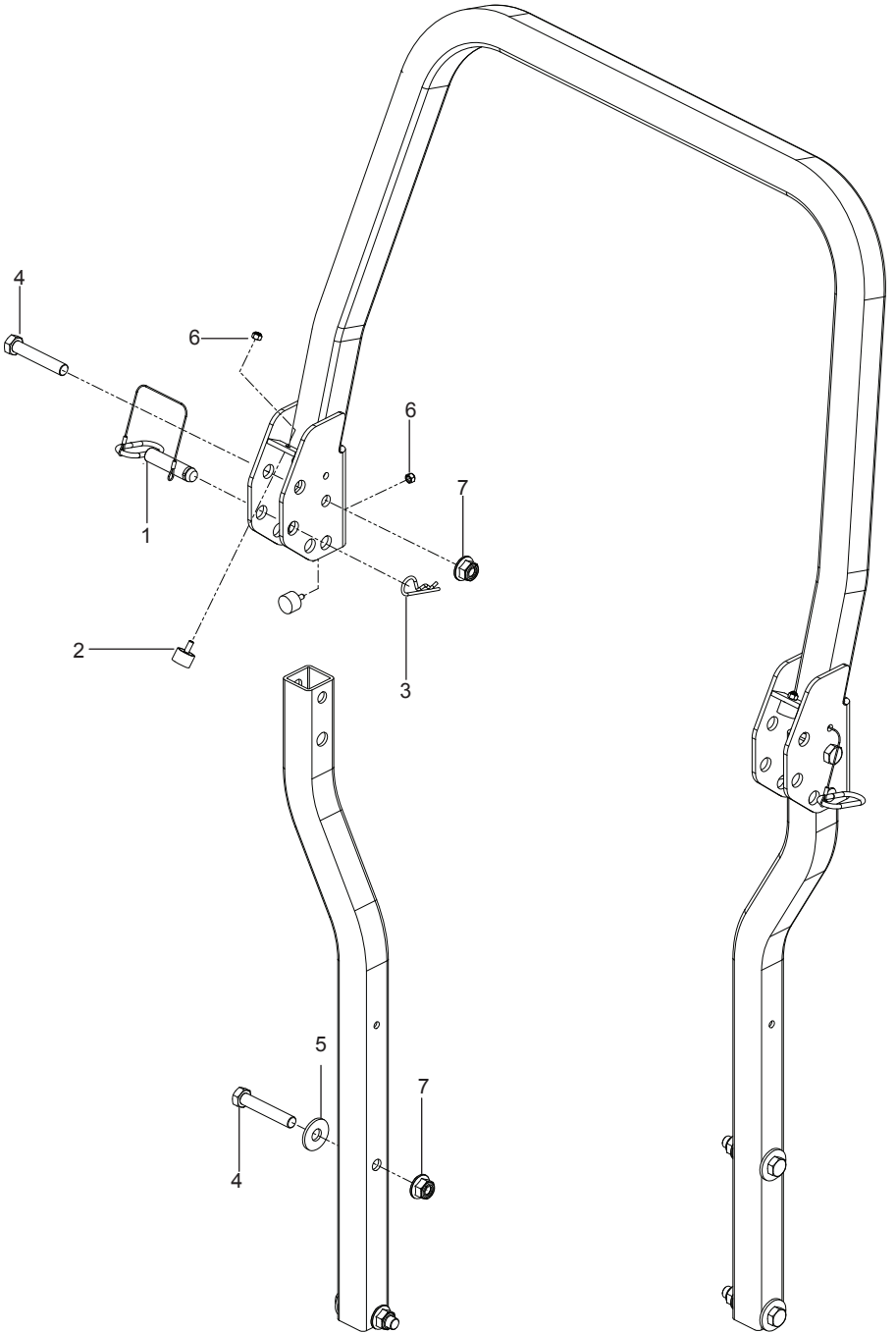

Ref.	Part No.	Qty	Description
1	574 38 80-01	2	Latch Pin w/ Lanyard
2	522 80 14-01	4	Bumper, Male Stud 1/4-20
3	539 20 07-15	2	Pin, Hair
4	580 75 46-01	6	Bolt 5/8-11 x 3-1/2 Hex Head
5	539 10 26-53	4	Washer 5/8 Std Flat
6	873 80 04-00	4	Nut 1/4-20 Hex Nyloc
7	525 82 91-01	6	Nut 5/8-11 Flange Nyloc
	NOT SHOWN		
	576 73 88-01	1	Assembly, ROPS

www.husqvarna.com

115 71 05-27 Rev B
2015-09-15