



Parts Manual

Zero Turn Mower / Z 248F

967 336701-00

Please read the operator manual carefully and make sure you understand the instructions before using the machine.



When you need spare parts or support in service questions, warranty issues, etc., please consult the following professional:

This manual belongs to the machine with the manufacturing number:	Engine	Transmission

Manufacturing Number

The machine's manufacturing number can be found on the printed plate affixed to the engine compartment.

Stated on the plate, from the top are:

- The machine's type designation (I.D.).
- The manufacturer's type number (Model).
- The machine's serial number (Serial no.)

Please have the type designation and serial number available when ordering spare parts.

CONTENTS

FRAME	4
ENGINE MOUNTING, GUARDS & MUFFLER	6
STEERING	8
IGNITION SYSTEM.....	10
BRAKE / LIFT	12
HYDRAULIC PUMP-MOTOR.....	14
WHEELS & TIRES	16
MOWER DECK / CUTTING DECK	18
SEAT	20
DECALS	22

Illustrations may or may not represent the actual assemblies and it is not recommended to use this manual as a guide to assemble or disassemble the mower.

NOTE: All fasteners are Grade 5 unless otherwise specified.

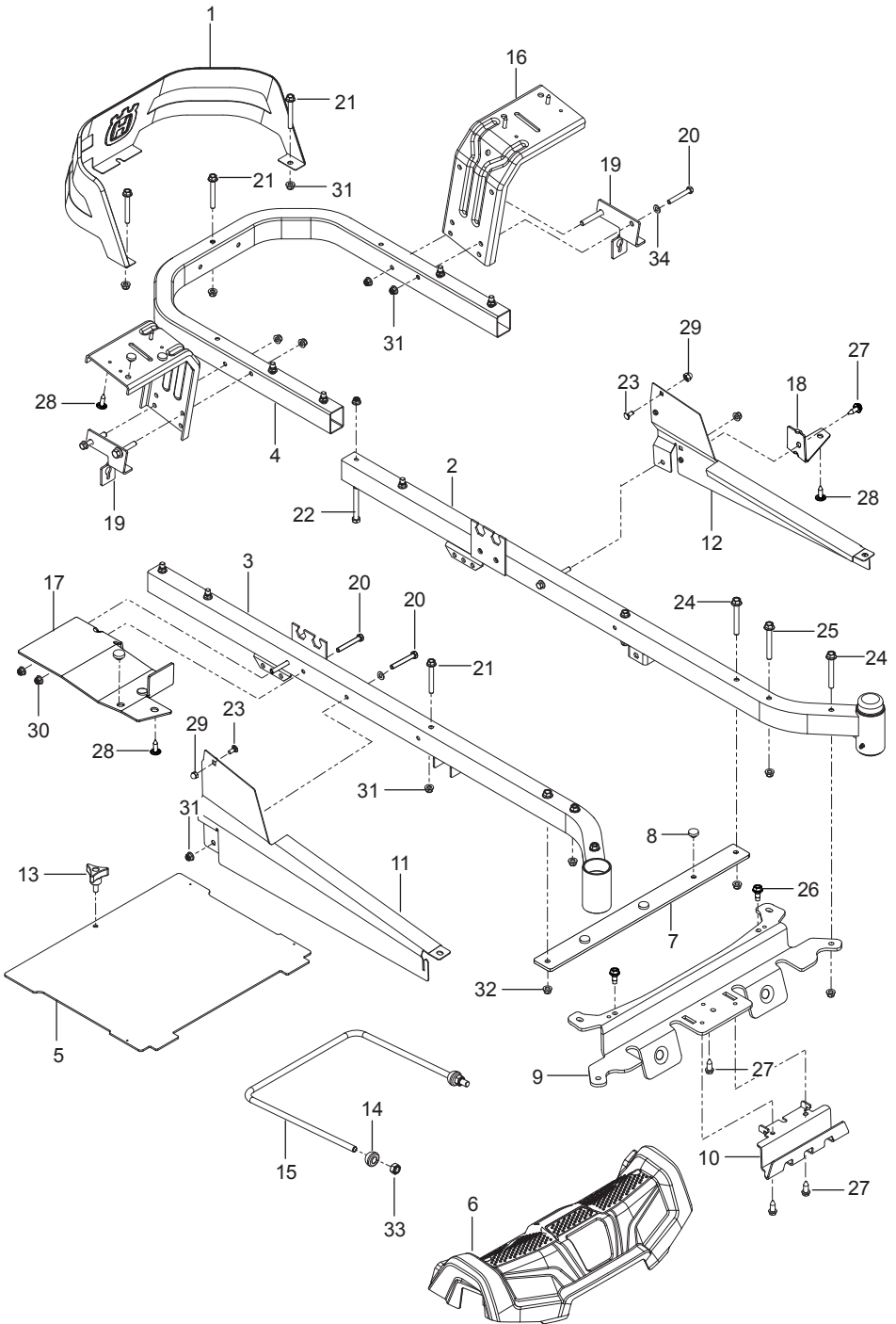

Ref.	Part No.	Qty	Description
1	585 03 98-02	1	Guard, Rear Blk
2	510 17 75-03	1	Frame, Front Right Org
3	510 17 74-03	1	Frame, Front Left Org
4	584 99 10-02	1	Frame, Rear Tube Org
5	522 84 29-02	1	Foot Plate w/ Safety Decal
6	585 52 24-01	1	Cover, Footrest
7	585 52 30-04	1	Support, Footrest
8	585 98 93-01	7	Grommet, Bumper
9	585 52 31-04	1	Cross Member
10	585 52 32-04	1	Plate, Skid Silv
11	585 33 16-02	1	Cover, Rail Right
12	585 33 15-02	1	Cover, Rail Left
13	539 10 44-11	1	Knob w/ Stud
14	532 19 52-63	2	Bushing, Pivot
15	521 93 81-01	1	Link, Front Suspension
16	580 50 13-02	2	Support, Fender Blk
17	585 52 34-04	1	Support, Console Right
18	585 52 36-04	1	Support, Console Left
19	585 47 43-02	2	Bracket, Bypass Rod
20	874 78 05-36	8	Bolt 5/16-18 x 2-1/4
21	874 49 05-44	5	Bolt 5/16-18 x 2-3/4
22	874 78 06-48	8	Bolt 3/8-16 x 3
23	585 94 00-01	2	Bolt 5/16-18 x 1 Carriage
24	577 11 77-01	4	Bolt 3/8-16 x 3
25	586 65 43-01	2	Bolt 3/8-16 x 3 Shoulder
26	586 88 11-01	2	Bolt 5/16-18 Shoulder
27	817 00 05-10	4	Screw 5/16-18 x 5/8 Washer Head
28	532 41 63-58	6	Screw #10-24 x 3/4 Hex Head
29	585 93 81-01	2	Nut 5/16-18 Acorn
30	873 90 05-00	2	Nut 5/16-18 Hex Flange Lock
31	539 11 28-99	9	Nut 5/16-18 Hex Flange Nyloc
32	521 99 65-01	8	Nut 3/8-16 Hex Flange Nyloc
33	539 11 91-24	2	Nut 7/16-14 Hex Nyloc
34	819 11 11-16	6	Washer 5/16 Sae Flat

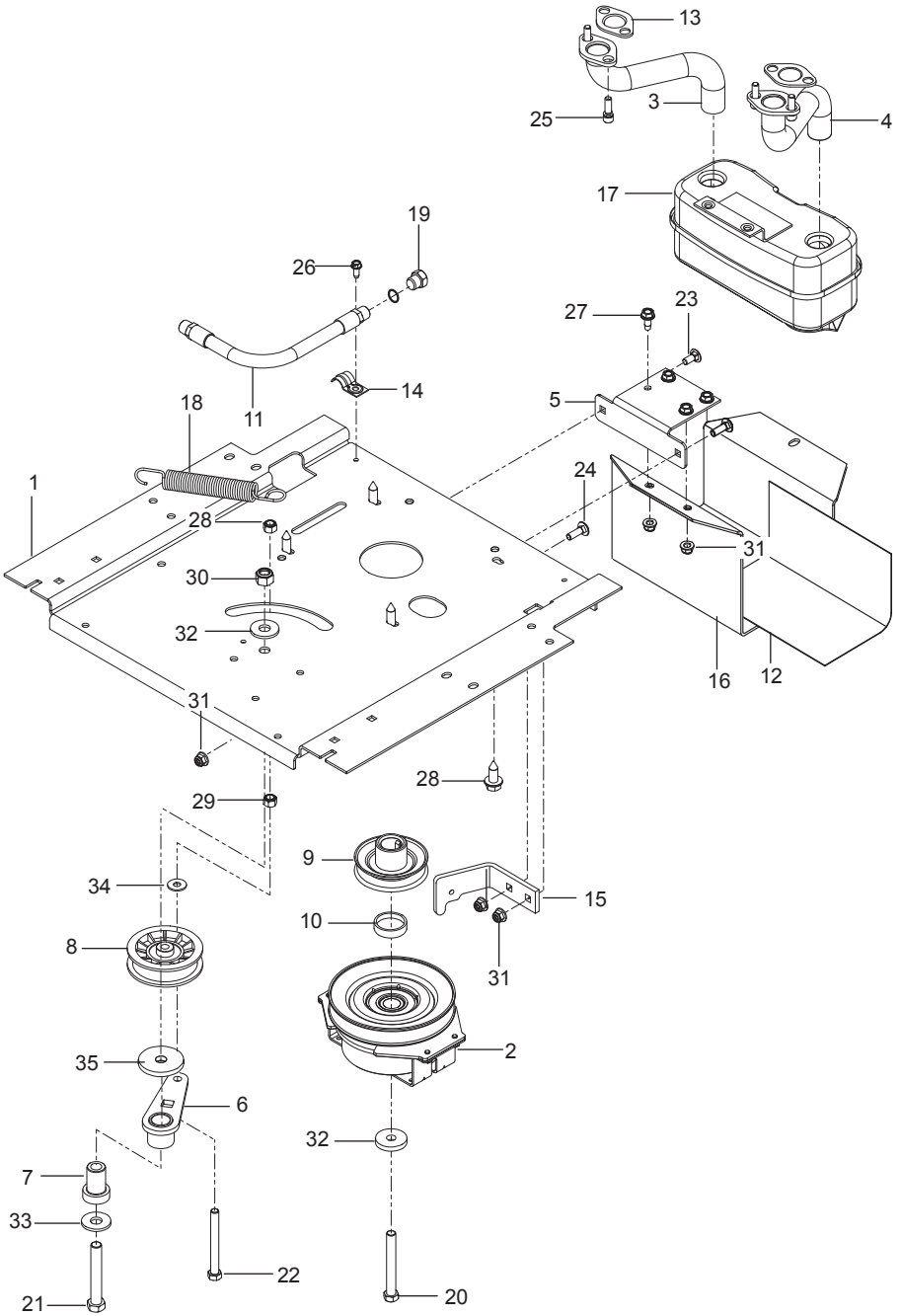

Ref.	Part No.	Qty	Description
1	588 01 71-02	1	Plate, Engine Blk
2	587 24 16-01	1	Clutch
3	532 19 15-49	1	Tube, Exhaust Right
4	532 19 15-48	1	Tube, Exhaust Left
5	581 88 67-02	1	Bracket, Muffler Blk
6	532 44 81-45	1	Arm, Idler
7	539 10 12-31	1	Spindle, Idler
8	539 11 03-11	1	Pulley, Idler
9	587 53 74-01	1	Pulley, Engine
10	587 66 01-01	1	Spacer
11	584 82 55-01	1	Hose, Drain
12	539 13 28-59	1	Shield, Muffler
13	587 45 12-02	1	Guard, Muffler Blk
14	539 10 13-63	1	Clamp
15	587 63 33-02	1	Stop, Clutch Blk
16	587 45 12-02	1	Guard, Muffler Blk
17	539 13 16-04	1	Muffler Assembly
18	532 19 61-05	1	Spring, Deck Drive
19	585 80 71-01	1	Plug, Hose
20	581 33 28-03	1	Bolt 7/16-20 x 2-1/2
21	874 78 08-52	1	Bolt 1/2-13 x 3-1/4
22	874 52 06-56	1	Bolt 3/8-16 x 3-1/2
23	872 14 05-08	2	Bolt 5/16-18 x 3/4 Round Head Square Neck
24	872 14 05-06	2	Bolt 5/16-18 x 1 Round Head Square Neck
25	532 19 24-43	4	Screw, Socket Head
26	817 49 04-10	1	Screw 1/4-20 x 5/8 Thread Form
27	817 49 05-12	4	Screw 5/16-18 x 3/4 Thread Form
28	817 12 06-16	4	Screw 3/8-16 x 1 Thread Form
29	539 97 69-79	2	Nut 3/8-16 Hex Nyloc
30	873 80 08-00	1	Nut 1/2-13 Hex Nyloc
31	539 11 28-99	5	Nut 5/16-18 Hex Flange Nyloc
32	532 12 61-97	1	Washer, Clutch
33	819 18 22-12	2	Washer 1/2 Flat
34	819 12 14-14	2	Washer 5/16 Std Flat
35	539 11 26-70	1	Washer, Heavy
	NOT SHOWN		
	-----	1	Engine, Briggs & Stratton 386777 23 Hp For Engine Replacement Parts, See a B&S Dealer

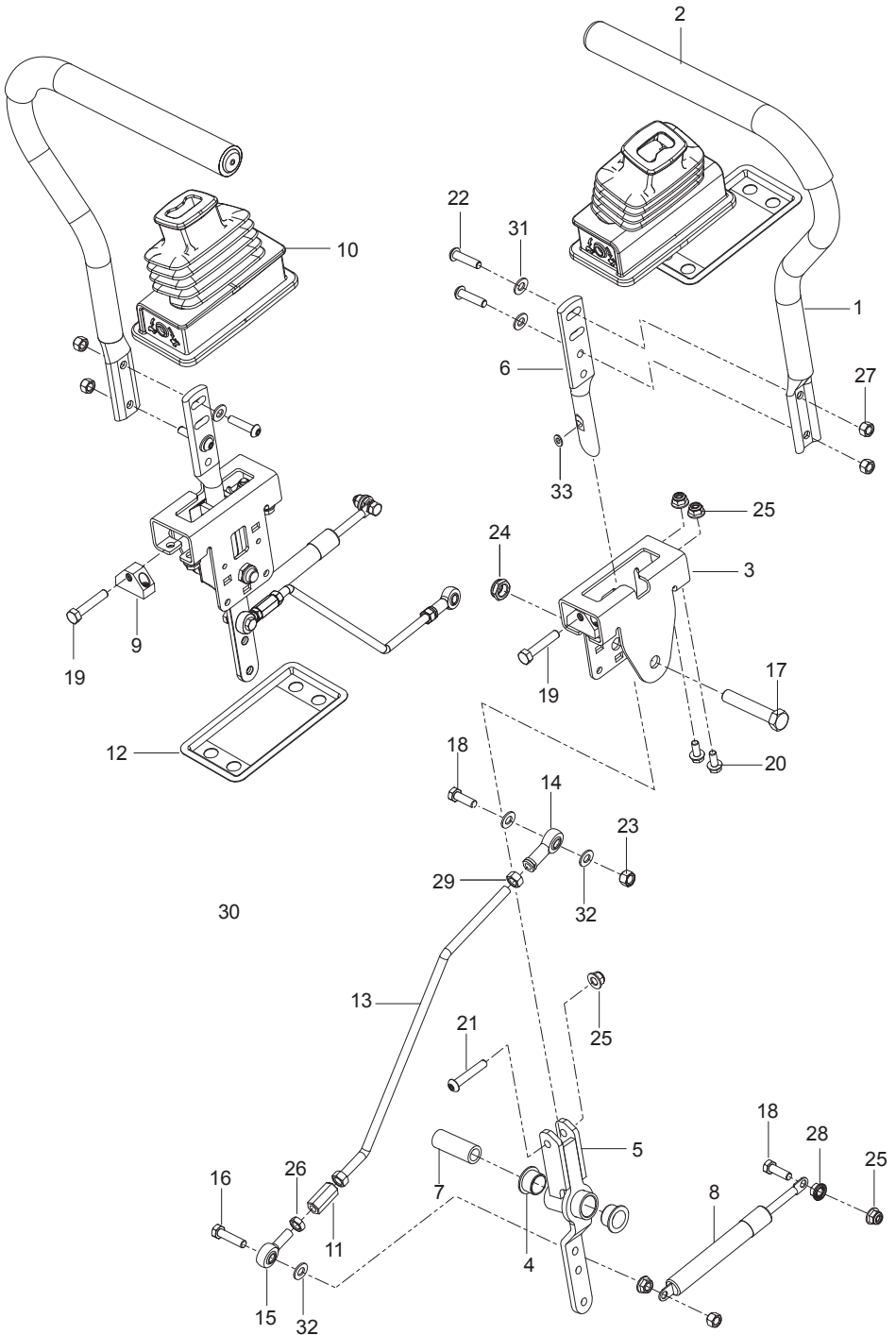

Ref.	Part No.	Qty	Description
1	581 82 67-01	2	Lever w/ Grip
2	525 39 29-01	2	Grip, Foam
3	585 12 47-05	2	Bracket, Control
4	539 13 15-18	4	Bearing, Flanged
5	576 14 03-01	2	Control, Lever
6	587 60 17-02	2	Lever, Handle
7	584 92 72-01	2	Spacer, Pivot Control
8	539 10 27-20	2	Dampener
9	581 43 75-01	2	Block, Tracking
10	585 83 16-01	2	Boot, Steering
11	539 11 66-89	2	Coupler, Rod End
12	585 48 82-02	2	Flange, Boot
13	580 62 42-01	2	Rod, Motion Control
14	539 11 57-29	2	Rod End Rh
15	539 11 66-90	2	Rod End Male Lh
16	874 78 05-28	2	Bolt 5/16-18 x 1-3/4 Tap Bolt
17	874 78 08-44	2	Bolt 1/2-13 x 2-3/4
18	874 78 05-16	4	Bolt 5/16-18 x 1 Thread Form
19	585 98 61-01	2	Bolt 5/16-18 x 1-1/4
20	874 49 05-12	8	Bolt Hex Flange 5/16-18 x 3/4
21	576 85 04-02	2	Screw 5/16-18 x 13/4 Button Head
22	585 98 59-01	4	Screw 5/16-18 x 1-1/4 Button Head Blk
23	873 80 05-00	2	Nut 5/16-18 Hex Nyloc
24	539 10 80-10	2	Nut 1/2-13 Hex Jam Nyloc Grade 2
25	539 11 28-99	12	Nut 5/16-18 Hex Flange Nyloc
26	873 70 05-00	2	Nut 5/16-24 Hex Jam Left Hand
27	585 98 60-01	4	Nut 5/16-18 Hex Nyloc Blk
28	539 99 05-85	4	Nut 5/16-18 Hex Whiz Lock
29	539 99 02-23	4	Nut 5/16-24 Hex
30	539 11 56-17	2	Nut 5/16-18 Thin Nyloc
31	586 30 91-01	4	Washer 5/16 Sae Flat Blk
32	819 11 11-16	6	Washer 5/16 Sae Flat
33	587 61 42-01	2	Washer 11/32

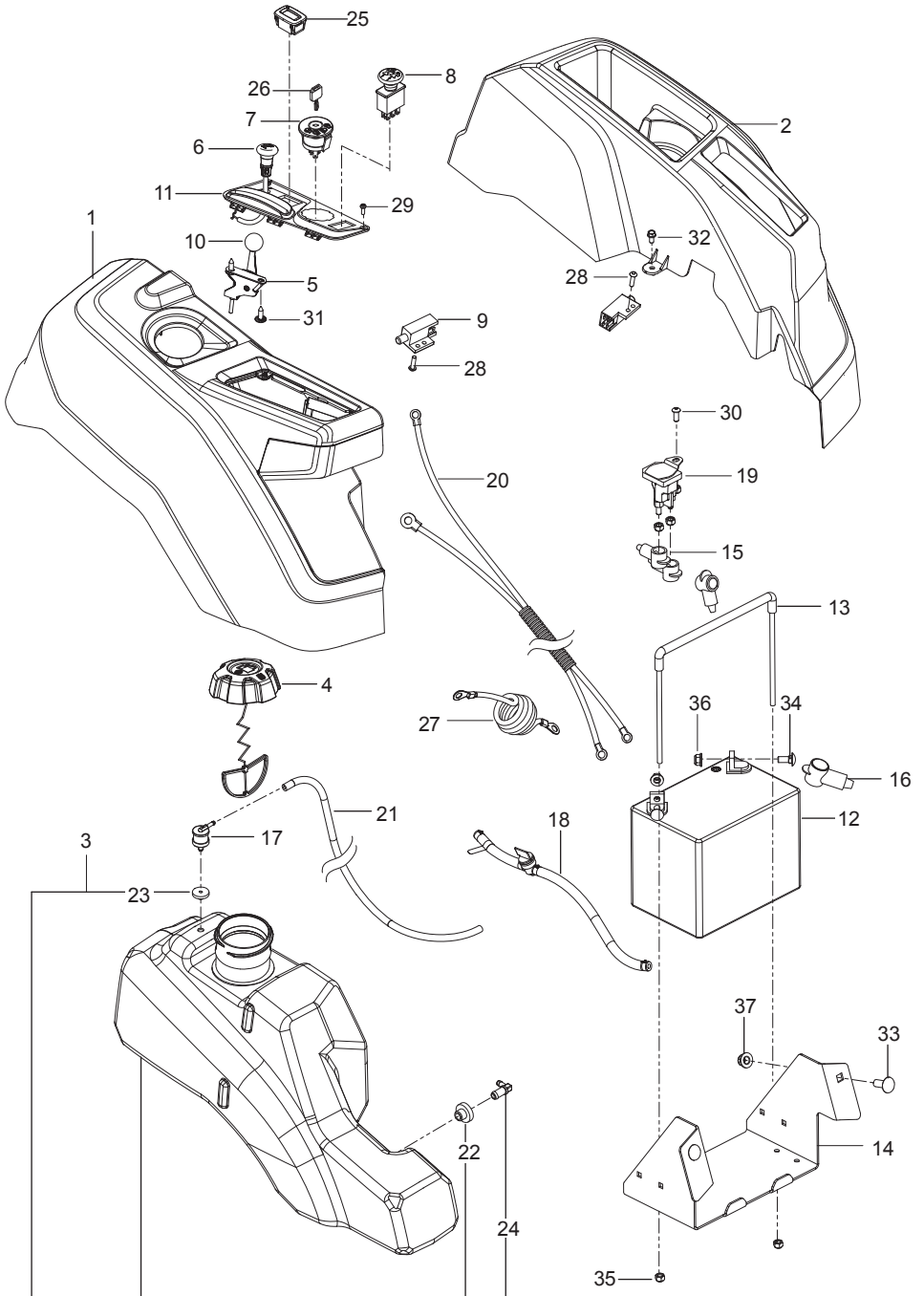

Ref.	Part No.	Qty	Description
1	585 52 28-01	1	Assembly, Fender, Right Gry
2	586 62 12 01	1	Assembly, Fender, Left Gry
3	578 18 06-02	1	Assembly, Fuel Tank
4	585 12 48-01	1	Cap, Fuel w/ Tether
5	539 11 24-38	1	Cable, Throttle
6	586 88 15-01	1	Control, Choke
7	539 10 75-41	1	Switch, Ignition
8	532 17 46-52	1	Switch, Clutch
9	587 60 15-01	2	Switch, Interlock
10	539 13 30-49	1	Knob
11	585 52 27-01	1	Panel, Control
12	539 10 24-36	1	Battery
13	539 13 12-09	1	Tie Down, Battery
14	585 04 87-02	1	Box, Battery Blk
15	532 13 15-63	3	Terminal Cover
16	539 10 27-59	1	Insulator
17	576 61 81-01	1	Valve, Fuel Check
18	586 12 39-02	1	Assembly, Fuel Line w/ Valve
19	532 19 25-07	1	Solenoid
20	587 19 86-01	1	Harness, Battery Cable
21	587 04 45-42	1	Hose 3/16 x 42" Vapor
22	532 00 36-45	1	Grommet, Rubber
23	532 43 74-92	1	Grommet, Check Valve
24	532 13 92-77	1	Elbow
25	586 16 18-01	1	Meter, Service
26	532 14 04-01	1	Key, Ignition
27	539 10 33-06	1	Cable, Battery Positive
28	586 93 60-01	2	Screw #10-24 x 1/2 Socket Head
29	545 22 71-01	2	Screw 6-19 x 7/16 Pan Head
30	539 11 12-29	1	Screw 1/4-20 x 5/8 Button Socket
31	532 14 18-41	2	Screw 10-16 x .65
32	817 49 04-08	2	Bolt 1/4-20 x 1/2
33	539 99 06-45	2	Bolt 3/8-16 x 1 Round Head Square Neck
34	872 14 05-06	2	Bolt 5/16-18 x 3/4 Round Head Square Neck
35	873 80 04-00	5	Nut 1/4-20 Hex Nyloc
36	539 11 28-99	2	Nut 5/16-18 Flange Nyloc
37	521 99 65-01	2	Nut 3/8-16 Hex Flange Nyloc
	NOT SHOWN		
	586 33 73-01	1	Harness, Wiring
	532 10 97-48	1	Relay 40A

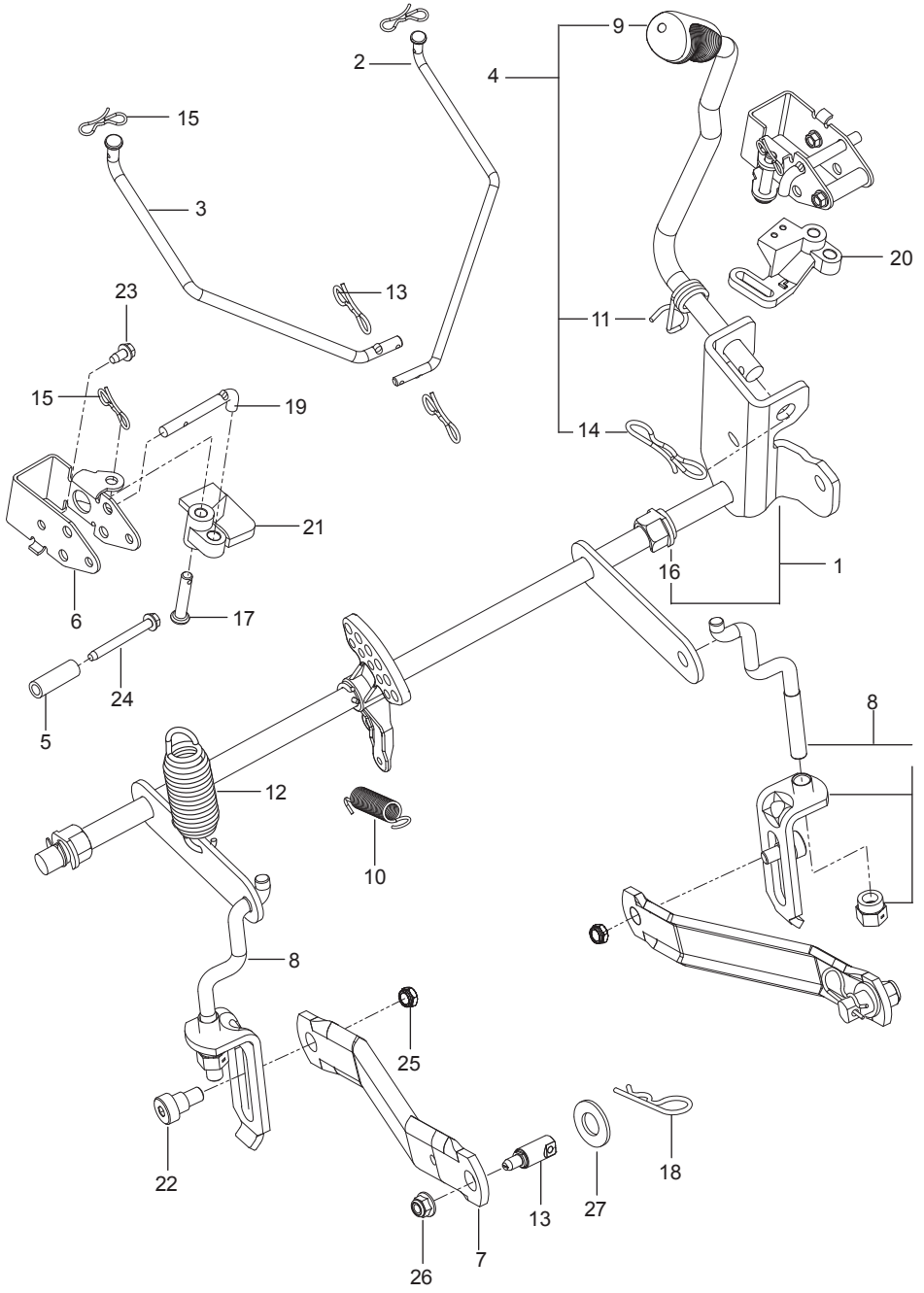

Ref.	Part No.	Qty	Description
1	587 62 31-01	1	Assembly, Shaft w/ Nuts, E-Rings
2	586 45 71-01	1	Link, Brake Left
3	586 45 72-01	1	Link, Brake Right
4	587 62 29-01	1	Assembly, Lift Handle
5	580 48 61-01	2	Spacer
6	585 68 21-01	2	Bracket, Bellcrank
7	532 19 51-85	2	Arm, Suspension
8	587 62 30-01	2	Assembly, Centering Lnk
9	532 44 50-60	1	Grip, Handle
10	586 86 76-01	1	Spring
11	532 19 63-14	1	Spring
12	539 11 87-62	1	Spring
13	532 19 51-61	2	Stud, w/ Anti-Rotate
14	532 19 42-09	1	Clip
15	587 22 53-01	6	Clip
16	510 18 49-01	2	Nut, Plastic
17	585 70 14-01	2	Pin 1/2 Clevis
18	539 97 69-89	2	Pin
19	585 68 20-01	2	Pushrod
20	586 45 74-01	1	Bellcrank Left
21	586 45 75-01	1	Bellcrank Right
22	532 19 65-39	2	Bolt, Shoulder
23	586 56 13-01	2	Screw 1/4-20 x 2-1/4 Thread Roll
24	532 13 77-29	2	Screw 1/4-20 x 5/8 Thread Roll
25	539 20 02-82	2	Nut 3/8-16 Hex Jam Nyloc
26	539 11 28-99	2	Nut 5/16-18 Hex Flange Nyloc
27	819 21 21-13	2	Washer 1/2 Flat

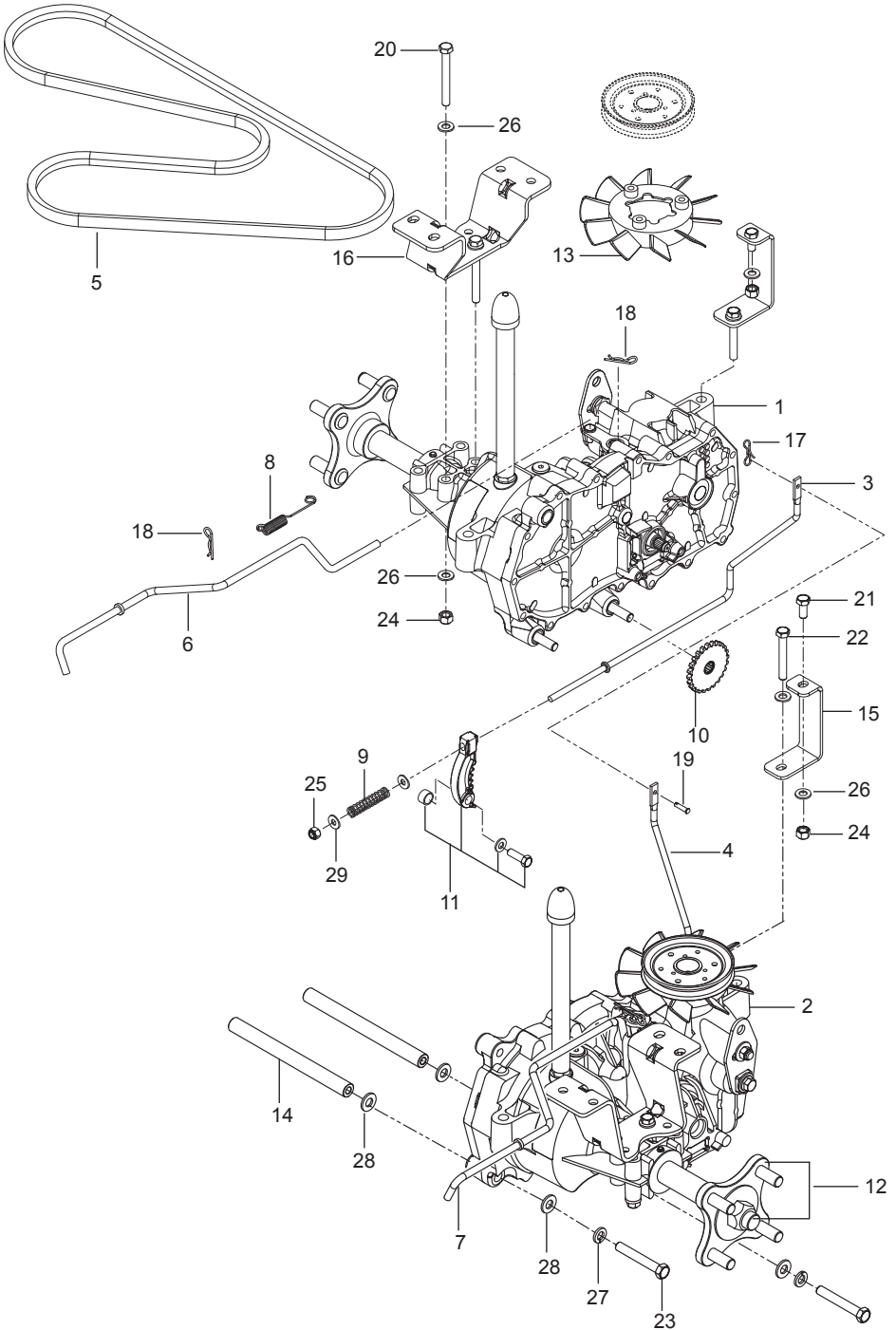

Ref.	Part No.	Qty	Description
1	510 37 56-01	1	EZT, Left
2	510 37 56-02	1	EZT, Right
3	574 03 05-01	1	Rod, EZT Brake Left
4	574 03 05-02	1	Rod, EZT Brake Right
5	539 11 04-11	1	Belt, EZT
6	585 47 44-01	1	Rod, Bypass Left
7	585 47 45-01	1	Rod, Bypass Right
8	586 66 51-01	2	Spring, Bypass
9	539 11 03-42	2	Spring, Brake Rod
10	539 12 00-80	2	Cog, Brake Disc
11	539 12 00-79	2	Assembly, Brake Arm
12	575 50 70-01	1	Assembly, Hub w/ Nuts
13	539 12 07-85	2	Blade, Fan
14	510 18 41-04	2	Spacer Tube
15	580 80 65-02	2	Support, EZT Front
16	580 80 66-02	2	Mount, EZT Rear Blk
17	587 22 53-01	1	Clip
18	539 97 69-88	4	Clip
19	587 11 53-01	1	Pin, Clevis
20	874 78 05-44	4	Bolt 5/16-18 x 2-3/4
21	874 78 05-12	2	Bolt 5/16-18 x 3/4
22	874 78 05-36	2	Bolt 5/16-18 x 2-1/4
23	874 78 06-40	4	Bolt 3/8-16 x 2-1/2
24	873 80 05-00	8	Nut 5/16-18 Hex Nyloc
25	873 80 04-00	2	Nut 1/4-20 Hex Nyloc
26	819 11 11-16	16	Washer 5/16 Sae Flat
27	810 03 06-00	4	Washer 3/8 Split Lock
28	819 13 13-16	8	Washer 3/8 Sae Flat
29	819 09 10-16	4	Washer 1/4 Sae Flat

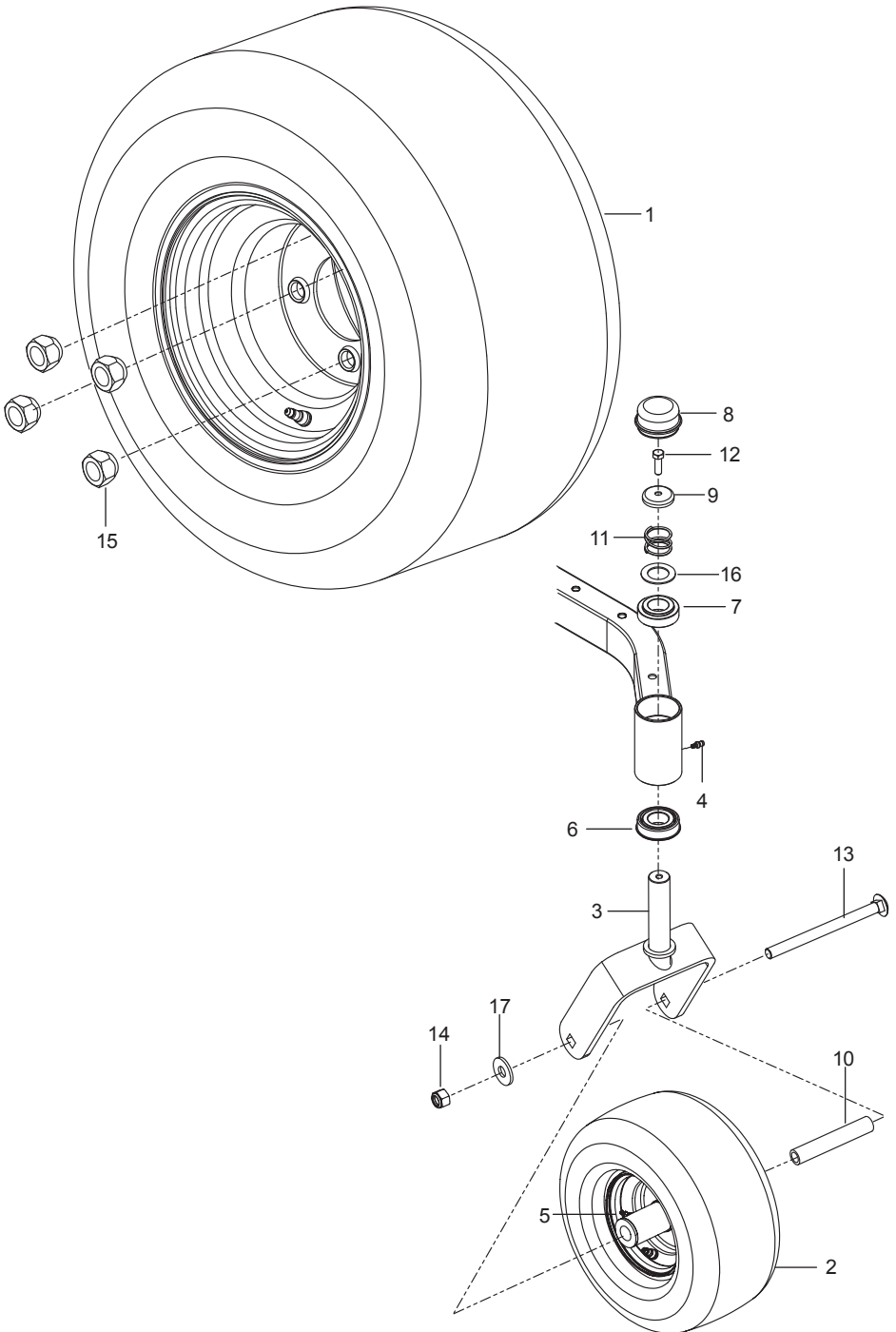

Ref.	Part No.	Qty	Description
1	579 75 34-01	2	Assembly, Wheel Rear 18 x 9.5
2	576 58 86-02	2	Wheel Assembly Caster 11 x 6.5
3	576 58 88-01	2	Yoke Org
4	539 11 56-38	2	Zerk 3/16 Drive
5	539 10 33-00	2	Zerk
6	539 11 26-60	2	Bearing, Flanged
7	539 11 79-01	2	Bushing, Caster
8	539 10 25-35	2	Grease Cap
9	539 11 57-49	2	Plug, Caster
10	576 58 89-01	2	Spacer, Pivot
11	539 11 57-47	2	Spring, Caster
12	874 95 05-16	2	Bolt, Hex 5/16-18 x 1 Nylon Patch
13	576 60 15-01	2	Bolt 1/2-13 x 7 Round Head Square Neck
14	873 93 08-00	2	Nut 1/2-13 Hex Center Lock
15	539 10 11-73	8	Nut 1/2 Lug
16	539 11 56-75	2	Washer
17	819 18 22-12	2	Washer 9/16

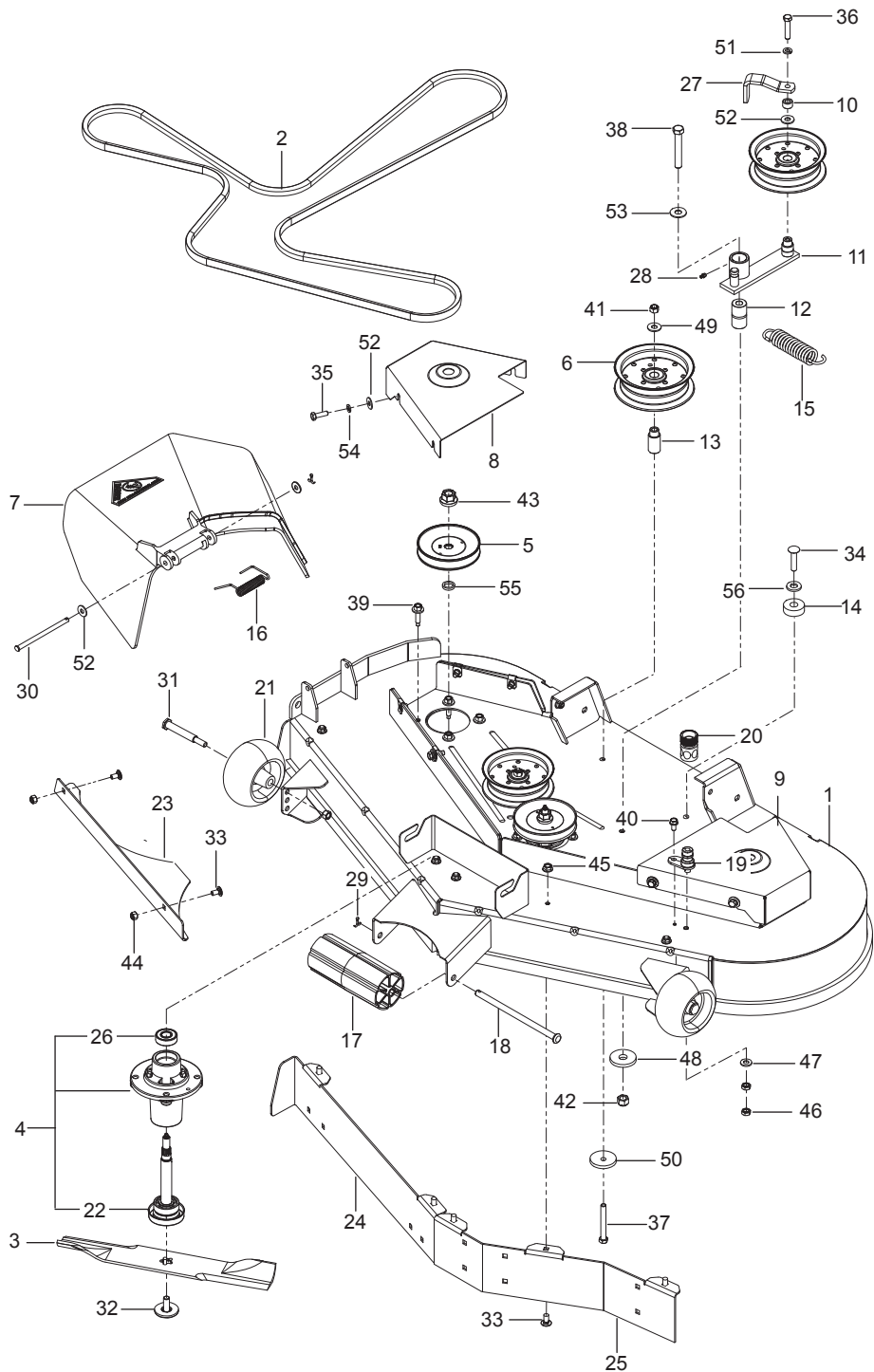

Ref.	Part No.	Qty	Description
1	587 66 89 01	1	Deck w/ Safety Decals
2	539 10 92-43	1	Belt, Deck
3	539 11 34-25	3	Blade
4	539 11 21-70	3	Assy, Mandrel
5	532 17 34-36	3	Pulley, Mandrel
6	539 13 27-28	3	Pulley, Idler
7	539 11 07-32	1	Chute, Discharge
8	539 11 34-11	1	Belt Shield, Right Org
9	539 11 34-13	1	Belt Shield, Left Org
10	539 92 35-15	1	Spacer
11	539 11 49-52	1	Arm, Idler
12	539 10 34-27	1	Bushing, Pivot
13	539 11 21-69	2	Bushing, Idler
14	539 11 63-78	1	Bushing, Iso Mount
15	539 10 32-56	1	Spring
16	539 11 07-35	1	Spring, Torsion
17	532 17 60-66	1	Roller, Nose
18	532 17 91-27	1	Rod, Roller Nose
19	532 41 55-98	1	Washout Port
20	532 41 64-05	1	Coupling, Connect
21	532 13 39-57	2	Wheel, Gauge
22	532 18 72-91	3	Shaft
23	539 11 34-27	1	Plate, Confinement Blk
24	584 65 15-01	1	Baffle, Front Left
25	580 94 16-01	1	Baffle Front Right
26	532 11 04-85	3	Bearing, Ball
27	539 11 49-81	1	Guide, Belt
28	539 97 69-98	1	Zerk
29	876 02 04-12	2	Pin, Cotter 1/8 x 3/4
30	539 11 07-36	1	Pin, Clevis 5/16
31	532 19 34-06	2	Bolt 3/8-16 x 35/8 Shoulder
32	532 19 30-03	3	Bolt 7/16 Blade
33	872 11 05-05	7	Bolt 5/16-18 x 5/8 Round Head Square Neck
34	539 99 09-23	1	Bolt 3/8-16 x 1-3/4 Round Head Square Neck
35	874 78 05-16	8	Bolt 5/16-18 x 1 Thread Form
36	874 78 06-28	1	Bolt 3/8-16 x 1-3/4 Hex Head
37	874 78 06-48	2	Bolt 3/8-16 x 3 Hex Head
38	874 78 08-52	1	Bolt 1/2-13 x 3-1/4 Hex Head
39	584 95 39-01	12	Screw, Washer Head
40	817 49 04-08	1	Screw 1/4-20 x 1/2 Hex Washer Head
41	539 97 69-79	4	Nut 3/8-16 Hex Nyloc
42	873 80 08-00	1	Nut 1/2 Hex Nyloc
43	532 40 02-34	3	Nut 9/16 Top Center Lock
44	873 80 05-00	2	Nut 5/16-18 Hex Nyloc
45	539 99 05-85	5	Nut 5/16 Hex Whiz Lock
46	873 35 06-00	2	Nut 3/8-16 Hex Jam
47	819 13 13-16	1	Washer 3/8 SAE Flat
48	539 10 65-04	2	Washer, Heavy
49	819 14 16-14	3	Washer 3/8 Std Flat
50	539 11 26-70	1	Washer, Heavy
51	810 03 06-00	1	Washer 3/8 Split Lock
52	819 12 14-14	10	Washer 5/16 Std Flat
53	819 18 22-14	1	Washer 1/2 Std Flat
54	810 03 05-00	8	Washer 5/16 Slotted Lock
55	532 18 76-90	3	Washer, Spacer
56	819 17 17-13	1	Washer, SAE Flat

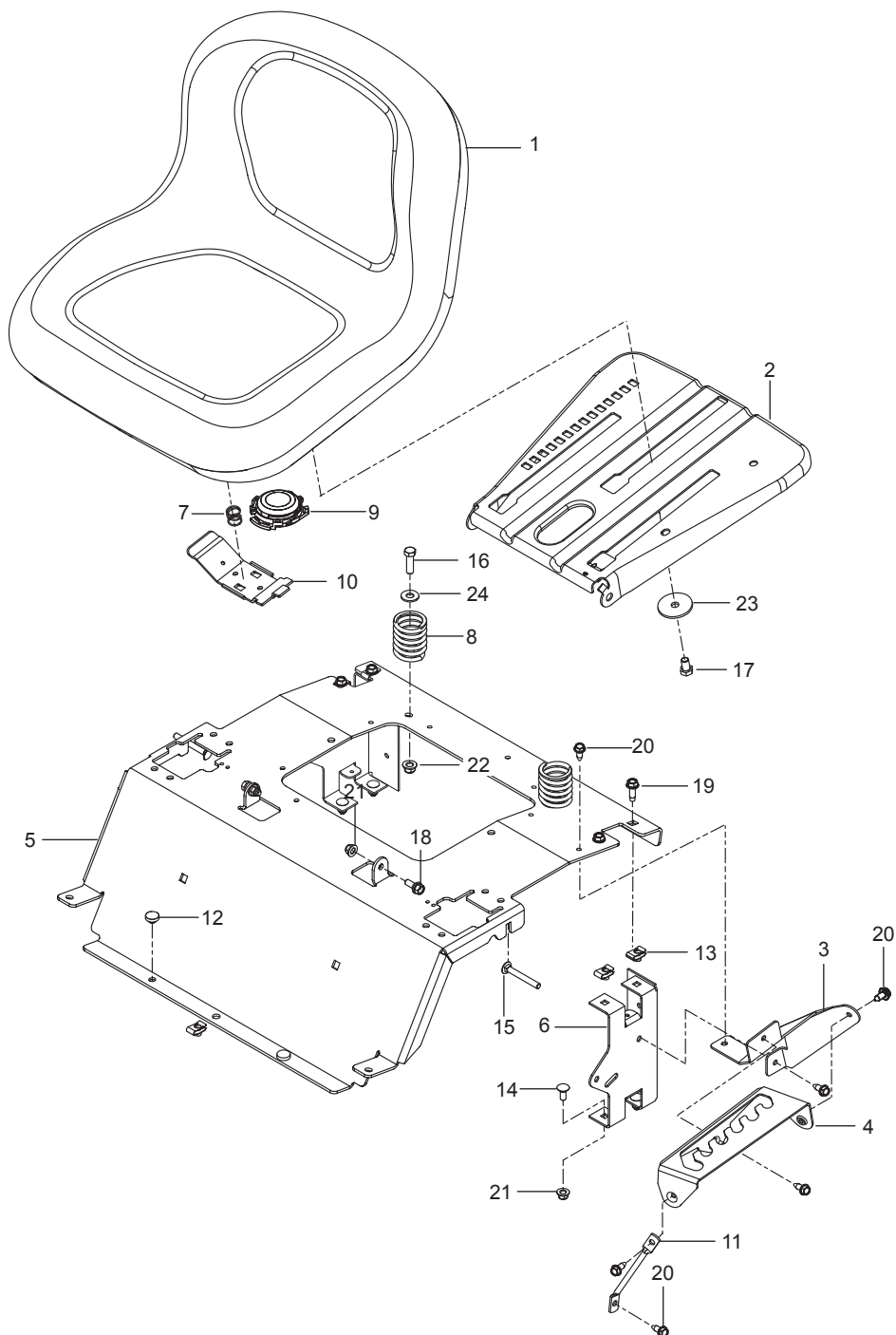

Ref.	Part No.	Qty	Description
1	532 43 98-22	1	Seat
2	532 19 69-77	1	Pan, Seat
3	586 22 08-02	1	Plate, Lift Support
4	586 22 12-02	1	Plate, Deck Lift
5	577 26 05-03	1	Support, Seat Org
6	580 30 82-02	2	Support, Seat Rear Blk
7	532 19 82-00	1	Spring, Latch
8	532 12 41-81	2	Spring, Seat
9	532 40 15-45	1	Switch, Seat
10	532 19 76-61	1	Handle, Slide
11	586 42 86-01	1	Leg, Support
12	585 98 93-01	2	Grommet, Bumper
13	539 10 47-63	5	Retainer, U Type
14	872 14 05-06	4	Bolt 5/16-18 x 3/4 Round Head Square Neck
15	510 42 27-01	2	Bolt 5/16-18 x 2-1/2 Round Head Square Neck
16	874 78 06-20	2	Bolt 3/8-16 x 1-1/4
17	874 78 06-10	1	Bolt 3/8-16 x 5/8
18	539 11 03-03	2	Bolt 5/16-18 Shoulder
19	817 49 05-12	4	Screw 5/16-18 x 3/4 Thread Form
20	817 00 05-10	6	Screw 5/16-18 x 5/8 Washer Head
21	539 11 28-99	4	Nut 5/16-18 Hex Flange Nyloc
22	521 99 65-01	2	Nut 3/8-16 Hex Flange Nyloc
23	539 11 18-97	1	Washer 3/8 Special
24	819 14 16-14	2	Washer 3/8 Std Flat

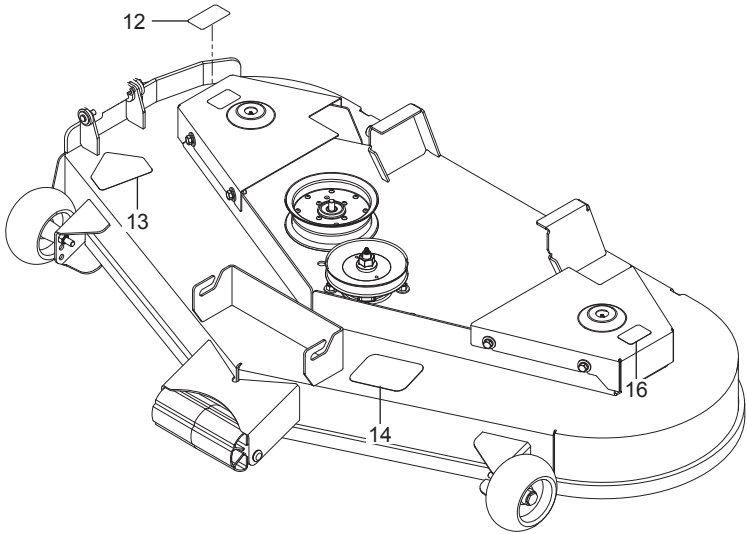
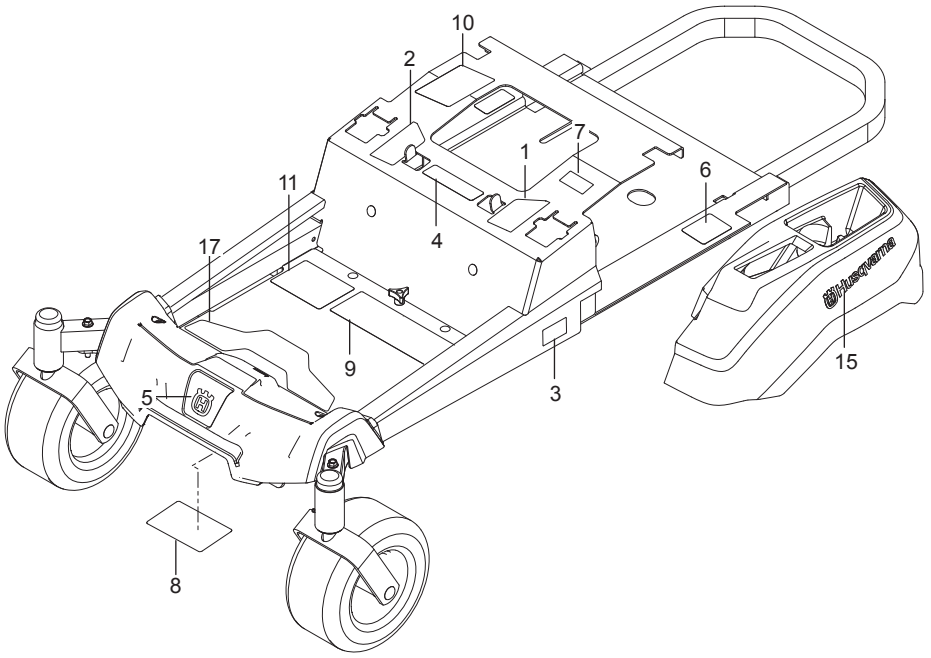

Ref.	Part No.	Qty	Description
1	587 59 56-01	1	Decal, Steer / Brake Left
2	587 59 55-01	1	Decal, Steer / Brake Right
3	587 22 03-01	2	Decal, Z 248F
4	539 10 57-45	1	Decal, Battery Warning
5	532 42 86-77	1	Decal, Crown
6	539 10 83-85	1	Decal, Do Not Tow
7	539 10 83-86	1	Decal, Exit Mower
8	539 10 98-97	1	Decal, Service
9	583 93 40 01	1	Decal, Safety Warnings
10	539 11 05-22	1	Decal, Responsibility
11	588 03 51-01	1	Decal, Start
12	581 72 44-01	1	Decal, Deflector
13	584 90 46-01	1	Decal, Blade Danger
14	539 11 26-20	1	Decal, Belt Routing
15	577 46 90-01	2	Decal, Husqvarna
16	581 72 43-01	2	Decal, No Step
17	587 00 07-01	1	Pad, Abrasive

www.husqvarna.com

115 73 76-27 Rev C
2015-12-15