

ILLUSTRATED PARTS LIST

MFG. ID NO. 96041038501

CUSTOMER CATALOG NO. TS 246

PRODUCT NO. 960 41 03-85

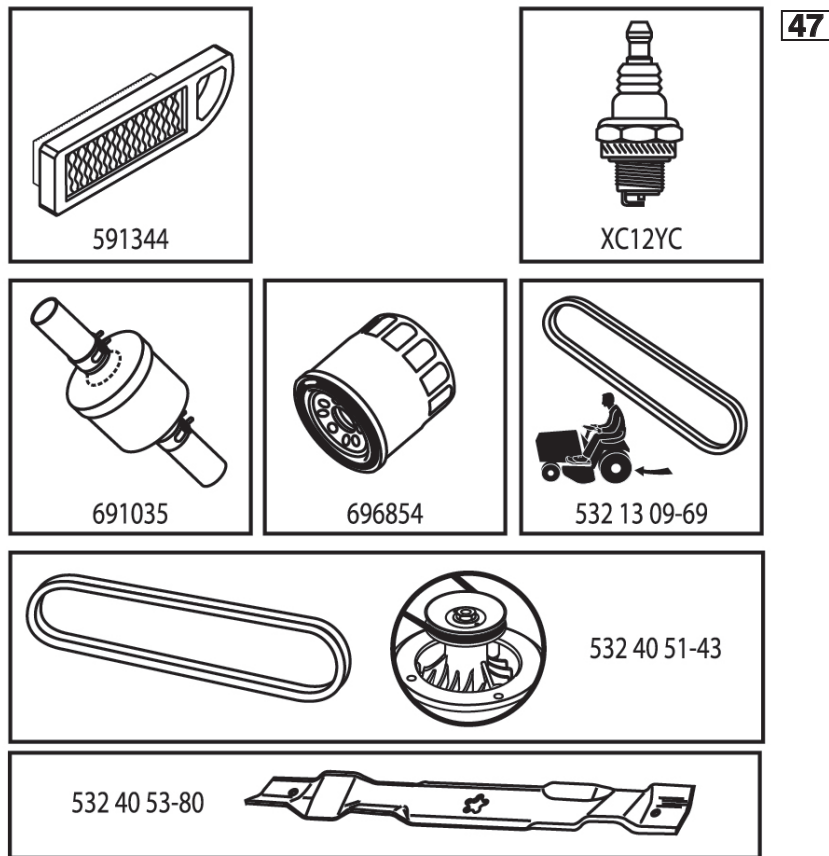

589804501

**TRACTOR - - MODEL NO. TS 246 (96041038501), PRODUCT NO. 960 41 03-85
DECALS 27**

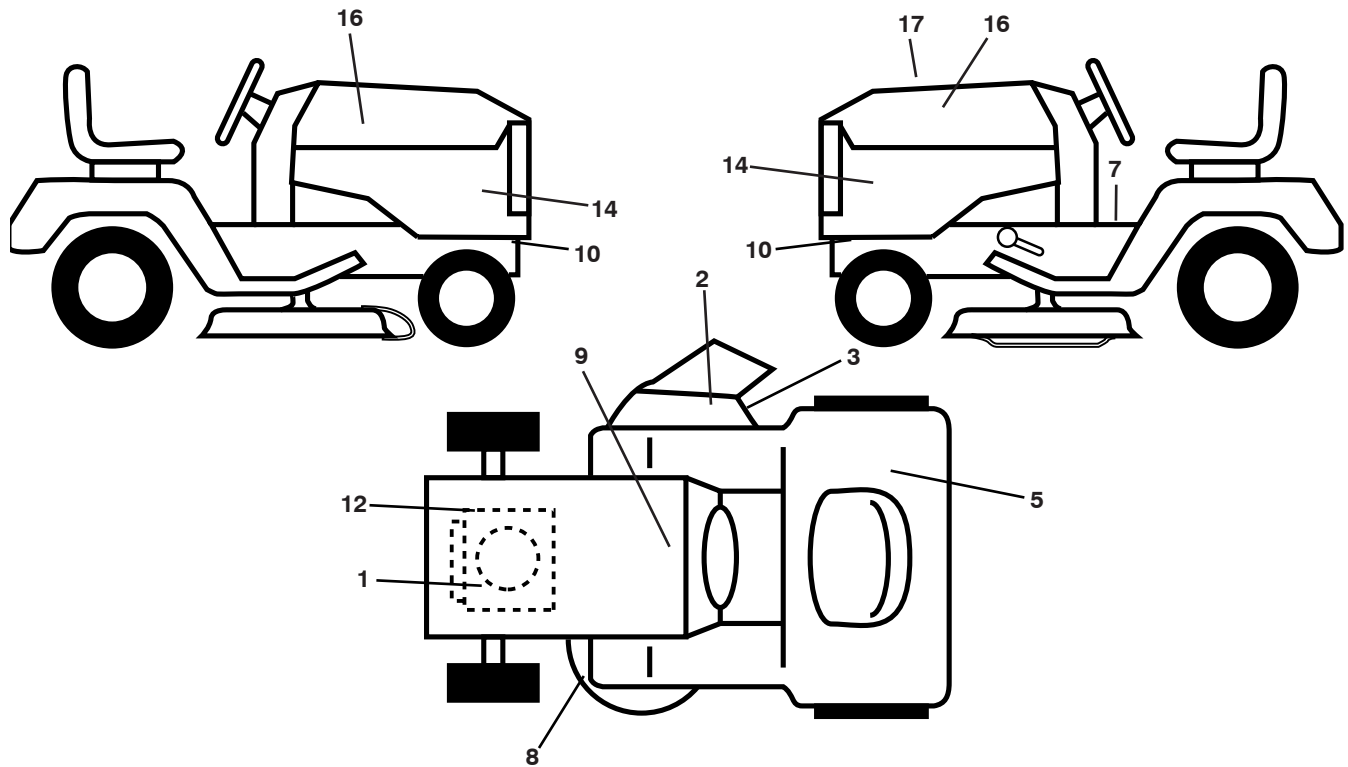

KEY NO.	PART NO.	DESCRIPTION
1	586 00 06-01	Decal, Engine
2	584 90 46-01	Decal, Deflect. Warning
3	581 57 92-01	Decal, Warning Symbol
5	501 08 26-01	Decal, ECM Australia
7	586 34 95-01	Decal, Trac. Fndr.
8	581 58 00-01	Decal, Mower Sch.
9	532 14 50-05	Decal, Battery Dnge/Poi
10	581 57 96-01	Decal, Hot Muffler
12	581 57 97-01	Decal, Warning Eng. Symbol

KEY NO.	PART NO.	DESCRIPTION
14	588 77 14-01	Decal, Panel Side
16	581 62 73-01	Emblem
17	589 80 45-01	Decal, Replacement
--	581 72 48-01	Decal, Bypass
--	581 72 46-01	Decal, Load Limit
--	532 43 96-81	Pad, Footrest, LH
--	532 43 96-82	Pad, Footrest, RH
--	115 86 69-28	Manual Oper. English

WHEELS AND TIRES

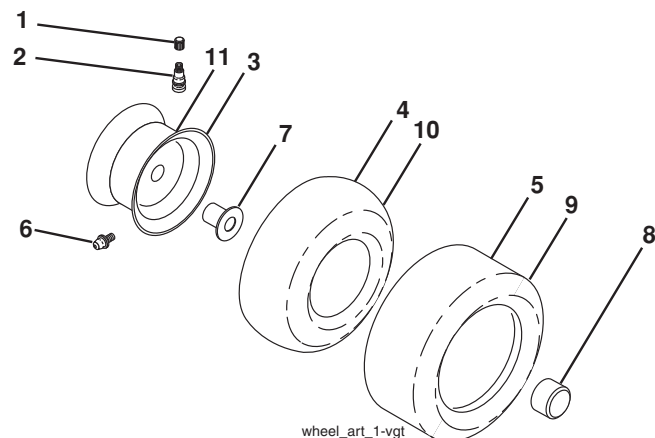

KEY NO.	PART NO.	DESCRIPTION
1	532 05 91-92	Cap, Valve, Tire
2	532 06 51-39	Stem, Valve
3	532 13 83-36	Rim Assembly, Front
4	532 05 99-04	Tube, Front (Service Item Only)
5	532 10 62-22	Tire, Front 15 x 6-6
6	532 12 49-57	Fitting, Grease (Front Wheel Only)
7	532 12 49-59	Bearing, Flange (Front Wheel Only)
8	532 17 50-39	Cap, Axle (Front Wheel Only)
9	532 12 20-82	Tire, Rear 20 x 10-8
10	532 12 49-26	Tube, Rear (Service Item Only)
11	532 13 83-37	Rim Assembly, Rear
--	532 14 43-34	Sealant, Tire (10 oz. Tube)

NOTE: All component dimensions given in U.S. inches
1 inch = 25.4 mm

TRACTOR - - MODEL NO. TS 246 (96041038501), PRODUCT NO. 960 41 03-85

SCHEMATIC **38**

SCH28

SMART IGNITION SWITCH (S.I.S.)



-DO NOT OPEN!
-PERMANENT DAMAGE CAN RESULT
IF PROPER DIAGNOSTIC PROCEDURES
ARE NOT FOLLOWED.
-CONTACT YOUR DEALER OR AUTHORIZED
SERVICE CENTER FOR REPAIR.



SENSITIVE ELECTRONIC
COMPONENTS INSIDE!



(COLOR: CONNECTOR NUMBER - PIN NUMBER)

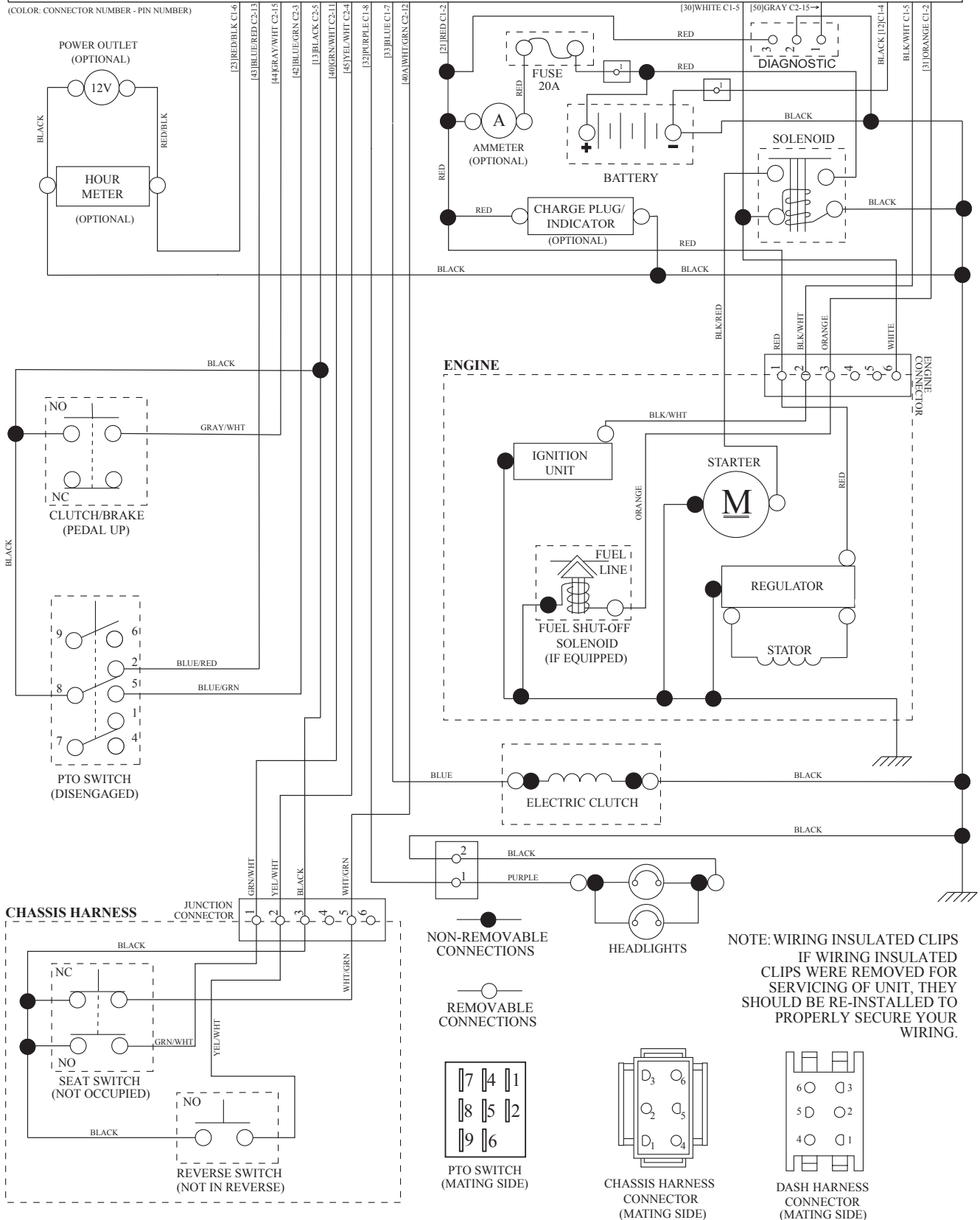

NOTE: WIRING INSULATED CLIPS
IF WIRING INSULATED
CLIPS WERE REMOVED FOR
SERVICING OF UNIT, THEY
SHOULD BE RE-INSTALLED TO
PROPERLY SECURE YOUR
WIRING.

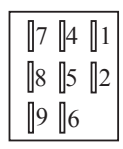
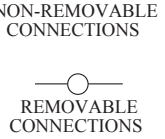

PTO SWITCH (MATING SIDE)

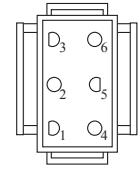

CHASSIS HARNESS CONNECTOR (MATING SIDE)

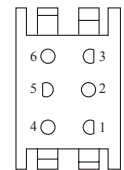

DASH HARNESS CONNECTOR (MATING SIDE)

TRACTOR - - MODEL NO. TS 246 (96041038501), PRODUCT NO. 960 41 03-85
ELECTRICAL 32

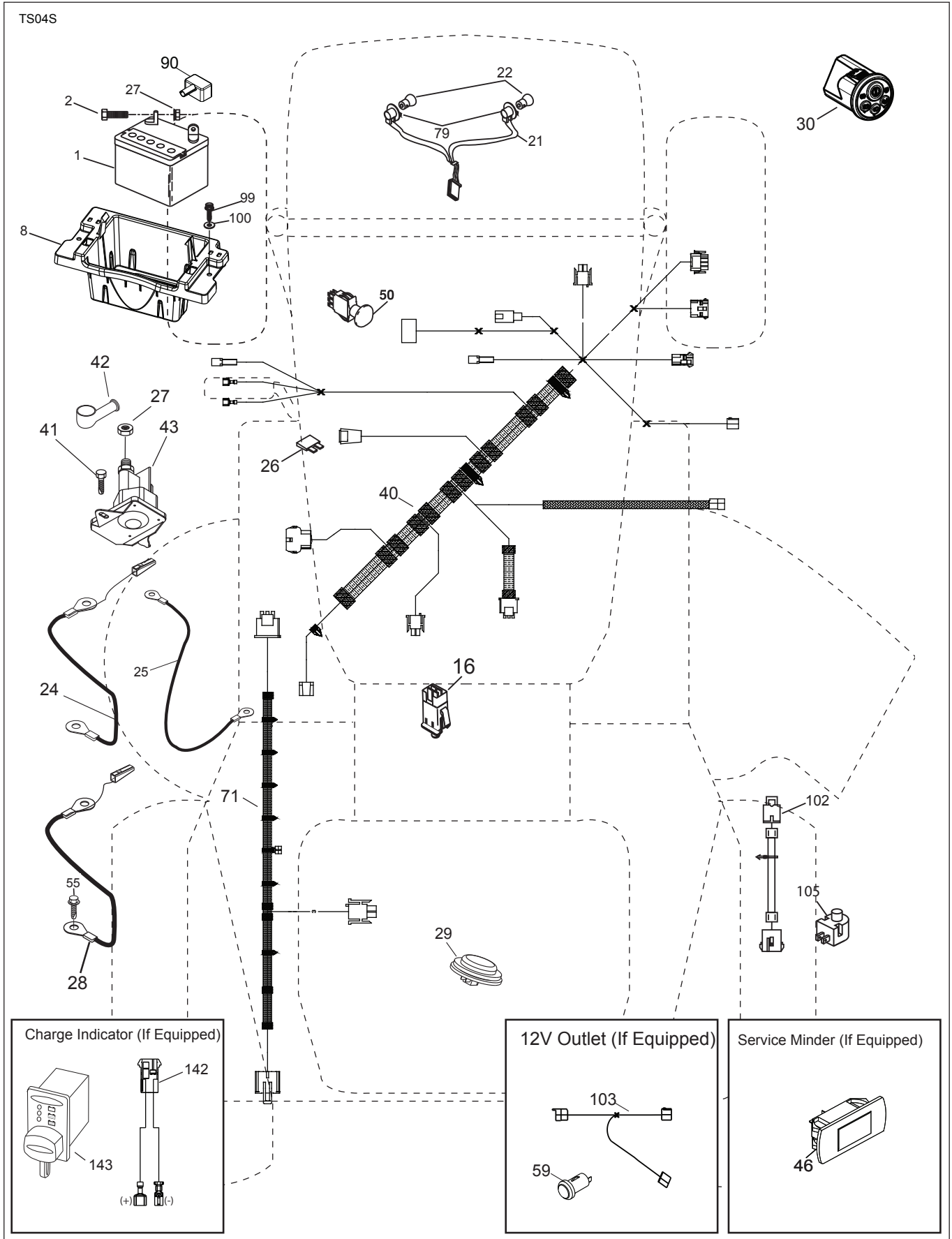

**TRACTOR - - MODEL NO. TS 246 (96041038501), PRODUCT NO. 960 41 03-85
ELECTRICAL 32**

KEY NO.	PART NO.	DESCRIPTION
1	532 16 34-65	Battery
2	874 76 04-12	Bolt Hex Hd 1/4-20 unc x 3/4
8	587 20 51-01	Battery Box
16	532 17 61-38	Switch Interlock
21	532 40 02-52	Harness Socket Light
22	532 00 41-52	Bulb, Light #1156
24	585 73 43-01	Cable Battery
25	585 55 55-01	Cable Starter
26	532 17 51-58	Fuse
27	873 51 04-00	Nut Keps Hex 1/4-20 unc
28	585 30 69-01	Cable Ground
29	581 42 93-02	Switch Seat
30	586 83 67-01	Switch. Smart
40	585 21 59-02	Harness Ign Dash
41	817 72 04-08	Screw Thd Cut 1/4-20 x 1/2
42	532 13 15-63	Cover Terminal Red
43	582 04 28-01	Solenoid
46	586 16 18-01	Gauge Hourmeter
50	582 10 76-01	Switch PTO
55	817 06 05-12	Screw Thdrol 5/16-18 x 3/4
71	585 21 60-01	Harness Ign. Chassis
79	532 17 52-42	Socket Asm. Bulb
90	532 43 53-95	Cover Terminal Battery
99	817 67 04-12	Screw Hexwsh Thdrol 1/4-20 x 3/4
100	819 09 14-16	Washer 9/32 x 7/8 x 16 Ga.
102	532 40 75-68	Switch Reverse
105	532 40 44-54	Harness Pigtail

NOTE: All component dimensions given in U.S. inches
1 inch = 25.4 mm

TRACTOR - - MODEL NO. TS 246 (96041038501), PRODUCT NO. 960 41 03-85
CHASSIS AND ENCLOSURES **39**

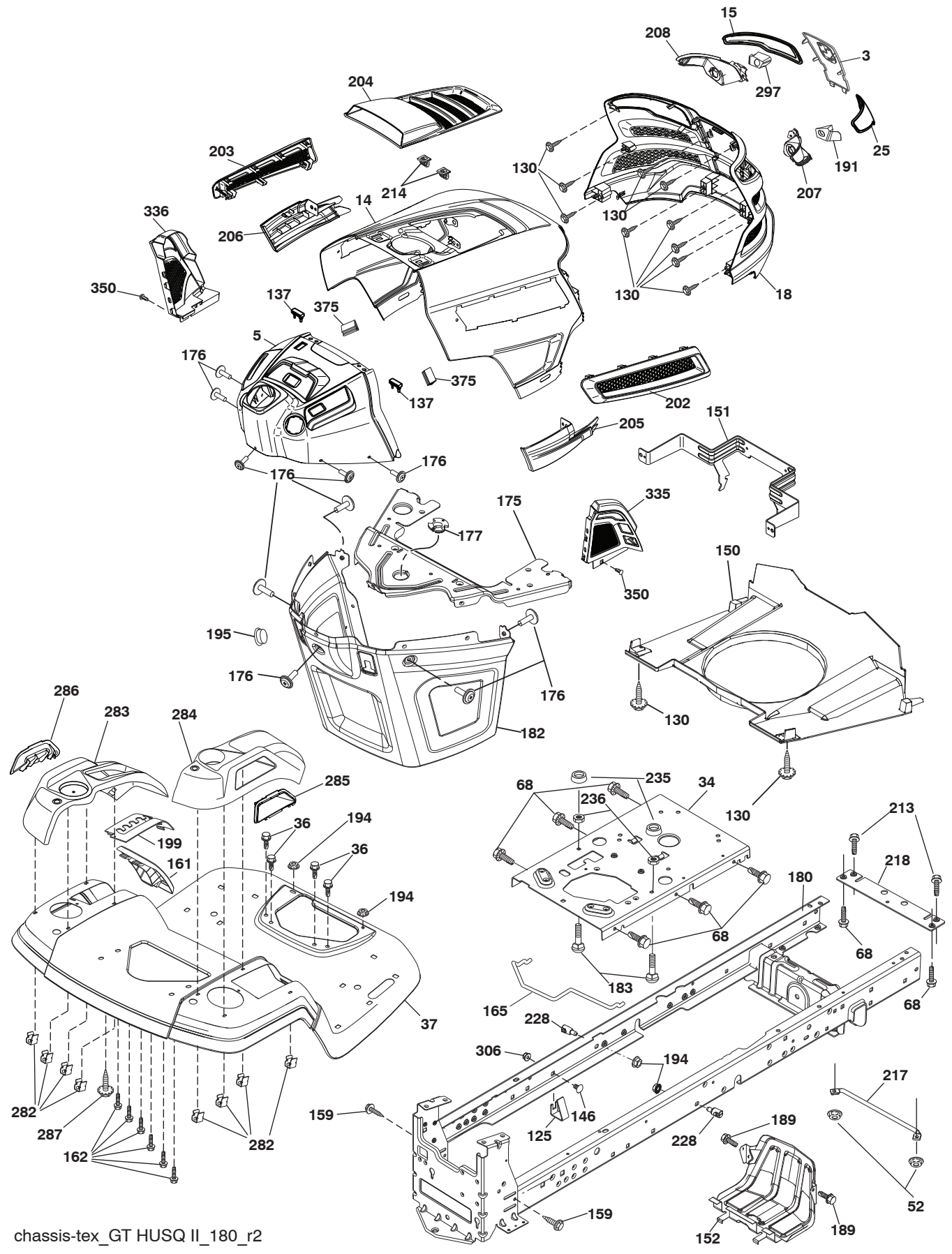

chassis-tex_GT HUSQ II_180_r2

**TRACTOR - - MODEL NO. TS 246 (96041038501), PRODUCT NO. 960 41 03-85
CHASSIS AND ENCLOSURES 39**

KEY NO.	PART NO.	DESCRIPTION	KEY NO.	PART NO.	DESCRIPTION
3	532 44 44-81	Logo	199	532 41 34-85	Plate Deck Lift
5	581 46 68-03	Dash	202	532 43 97-28	Vent Side Hood RH
14	532 44 11-77	Hood	203	532 43 97-27	Vent Side Hood LH
15	532 43 97-33	Lens LH	204	532 43 57-14	Vent Top Hood
18	587 52 34-01	Grille	205	532 43 97-30	Trim Hood Side RH
25	532 44 33-85	Lens RH	206	532 43 97-29	Trim Hood Side LH
34	580 91 08-01	Plate Engine	207	587 46 48-01	Bezel RH
36	817 06 05-12	Screw 5/16-18 x 3/4	208	587 46 45-01	Bezel LH
37	587 57 48-01	Fender	213	874 76 05-12	Bolt 5/16-18 unc x 3/4
52	873 68 05-00	Nut Lock 5/16-18	214	532 19 91-45	Clip Retainer Tinner
68	817 49 05-08	Screw 5/16-18 x 1/2	217	532 40 91-67	Rod Pivot
125	581 68 48-01	Clip Fuel Line	218	532 19 63-95	X-Piece Hood Stop
130	532 41 63-58	Screw #10 x 0.750 BOS Thread	228	532 19 51-61	Stud Fastner
137	532 40 75-90	Bumper Dash	235	532 40 61-29	Spacer Fender
146	581 85 79-01	Bolt	236	873 93 05-00	Nut Lock 5/16-18 unc
150	532 43 97-74	Air Duct	282	532 41 41-10	Clip Retainer Console
151	532 43 66-70	Bracket Pivot	283	532 44 20-39	Console Asm. Decklift
152	532 43 98-70	Shield Browning	284	532 43 98-23	Console Asm.
159	817 00 06-12	Screw hexwsh 3/8-16 x 3/4	285	532 41 63-15	Console Insert RH
161	532 44 00-29	Window Fuel	286	532 41 63-17	Console Insert LH
162	532 14 24-32	Screw	287	817 60 04-06	Screw Hex Washead 1/4-20 x 3/8
165	532 19 68-26	Support Tank Rear	297	532 43 74-56	Insert Reflective LH
175	532 19 63-04	Crossmember	306	873 90 06-00	Nut
176	532 40 07-76	Screw 10-24 x 5/8	335	532 44 82-04	Cover Lower Dash Close Out RH
177	532 19 52-28	Bushing Steering	336	532 44 53-09	Cover Lower Dash LH
180	532 19 54-57	Chassis	350	532 44 51-43	Clip X-mas Tree
182	532 40 68-59	Dash Lower	375	586 90 82-01	Dash Clip-On Bumper
183	874 52 05-20	Bolt Fin Hex 5/16-18 unc x 1-1/4	--	586 29 76-01	Plug Switch
189	817 00 05-12	Screw 5/16-18 x 3/4	--	532 40 09-44	Bumper
191	532 43 74-55	Insert Reflective RH			
194	873 90 05-00	Nut Lock Hex Flange 5/16-18			
195	532 40 41-37	Plug Hole Dash Lower			

NOTE: All component dimensions given in U.S. inches
1 inch = 25.4 mm

TRACTOR - - MODEL NO. TS 246 (96041038501), PRODUCT NO. 960 41 03-85
DRIVE 40

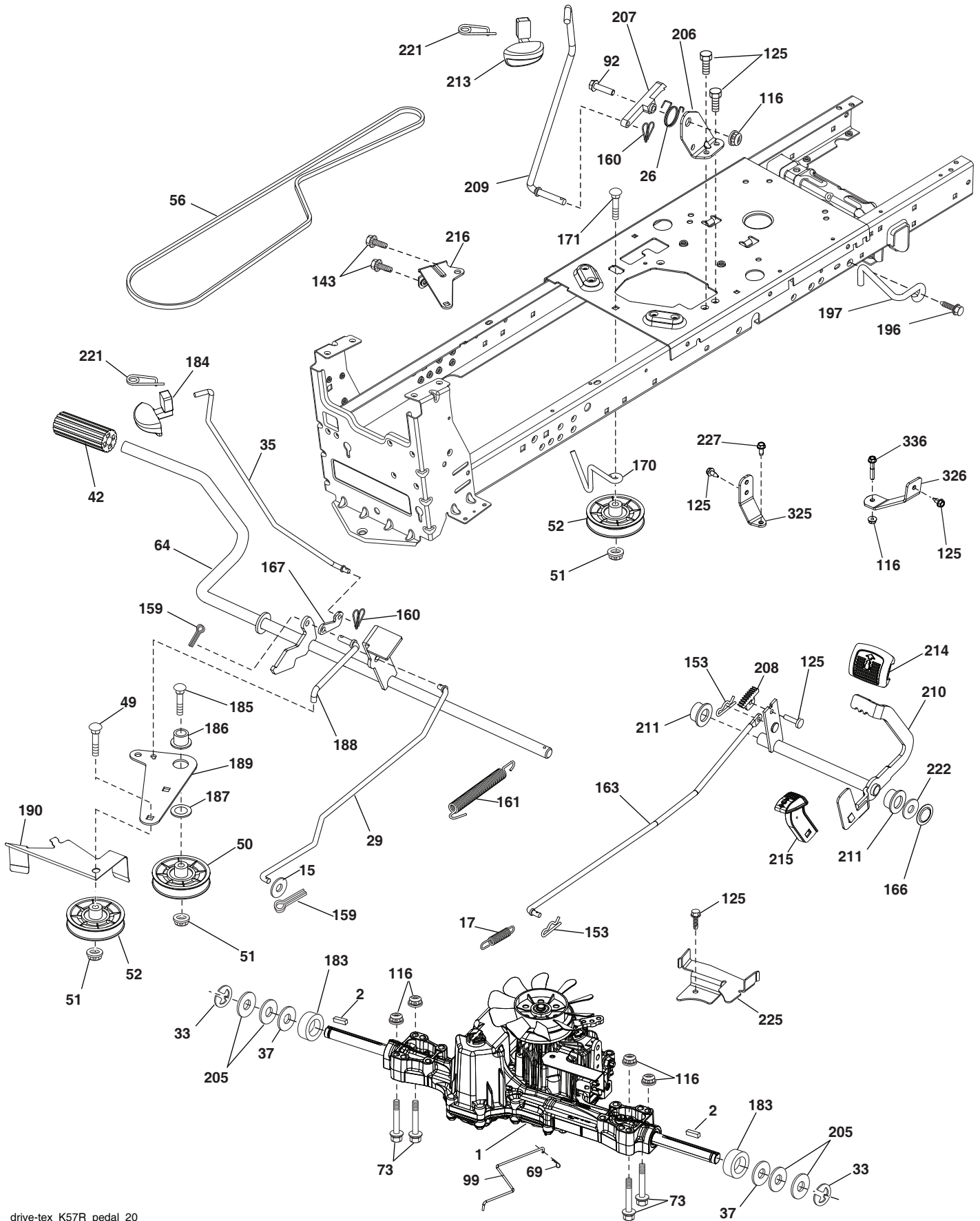

**TRACTOR - - MODEL NO. TS 246 (96041038501), PRODUCT NO. 960 41 03-85
DRIVE **40****

KEY NO.	PART NO.	DESCRIPTION	KEY NO.	PART NO.	DESCRIPTION
1	— — — — —	Transaxle, TUFFTORQ K57R (437814) (Order parts from trans-axle manufacturer)	170	532 19 43-22	Keeper Belt Centerspan
2	532 12 35-83	Key	171	872 11 06-16	Bolt RDHD SQNK 3/8-16 unc x 2
15	819 13 13-16	Washer 13/32 x 13/16 x 16 Ga.	183	532 13 70-57	Spacer Split
17	532 41 36-78	Spring Brake	184	587 65 37-01	Handle Parking Brake
26	532 19 96-79	Spring Return Cruise	185	872 11 06-22	Bolt Rdhd Sqnk 3/8-16 x 2-3/4 Gr. 5
29	532 40 38-06	Rod, Brake	186	532 19 43-21	Spacer Retainer
33	812 00 00-01	Ring E	187	819 13 32-10	Washer
35	583 86 45-01	Rod Brake Park	188	582 21 70-01	Link Clutch Ground Drive, Long
37	532 18 89-67	Washer Hardened	189	532 19 43-17	Bellcrank Ground Drive
42	532 12 48-72	Cover Foot Pedal	190	532 19 43-18	Keeper Bellcrank Ground Drive
49	872 11 06-14	Bolt	196	817 00 06-16	Screw 3/8-16 x 1
50	532 19 43-27	Pulley Idler Flat	197	585 65 86-01	Link Clutch Anti-Rotation
51	873 90 06-00	Lock Nut 3/8-16	205	532 12 17-48	Washer
52	532 19 43-26	Idler V-Groove	206	532 44 85-96	Bracket Mount Latch Cruise
56	532 13 09-69	V-Belt Drive	207	587 03 14-01	Latch Cruise Control
64	532 19 78-65	Shaft Asm. Pedal Brake Control	208	532 19 78-69	Gear Sector Cruise Control
69	532 42 33-03	Hairpin Soft Zink .059 x 1.125	209	532 19 95-92	Rod Cruise Control
73	874 49 05-40	Bolt 5/16-18 x 2-1/2 Gr. 5	210	532 40 09-80	Rocker Asm. Pedal
92	874 76 05-20	Bolt Fin. Hex. 5/16-18 unc x 1.25	211	532 12 01-83	Bushing Brake Shaft
99	582 40 45-01	Rod Bypass	213	532 40 31-19	Knob Control Cruise
116	873 90 05-00	Nut Lock Hex Flange 5/16-18	214	532 42 12-63	Pedal Forward
125	817 00 05-12	Screw 5/16-18 x 3/4	215	586 60 65-02	Pedal Reverse
143	817 49 05-08	Screw 5/16-18 x 1/2	216	532 19 61-31	Bracket Pulley Idler
153	532 12 47-88	Retainer Spring	221	532 40 31-87	Retainer Spring Clip Handle
159	876 02 04-12	Pin Cotter 1/8 x 3/4	222	879 21 20-10	Washer 21/32 x1-1/4 10 Ga.
160	532 16 94-84	Retainer Clip	225	532 40 33-19	Keeper Belt Trans.
161	532 10 57-09	Spring Return Clutch	227	817 49 05-12	Screw 5/16-18 x 3/4
163	532 44 82-75	Rod Control Pedal	325	585 66 85-02	Bracket
166	532 42 91-64	Nut Push	326	585 67 08-02	Bracket
167	532 40 52-57	Latch Brake Parking	336	587 25 96-01	Bolt

NOTE: All component dimensions given in U.S. inches
1 inch = 25.4 mm

TRACTOR - - MODEL NO. TS 246 (96041038501), PRODUCT NO. 960 41 03-85
ENGINE **24**

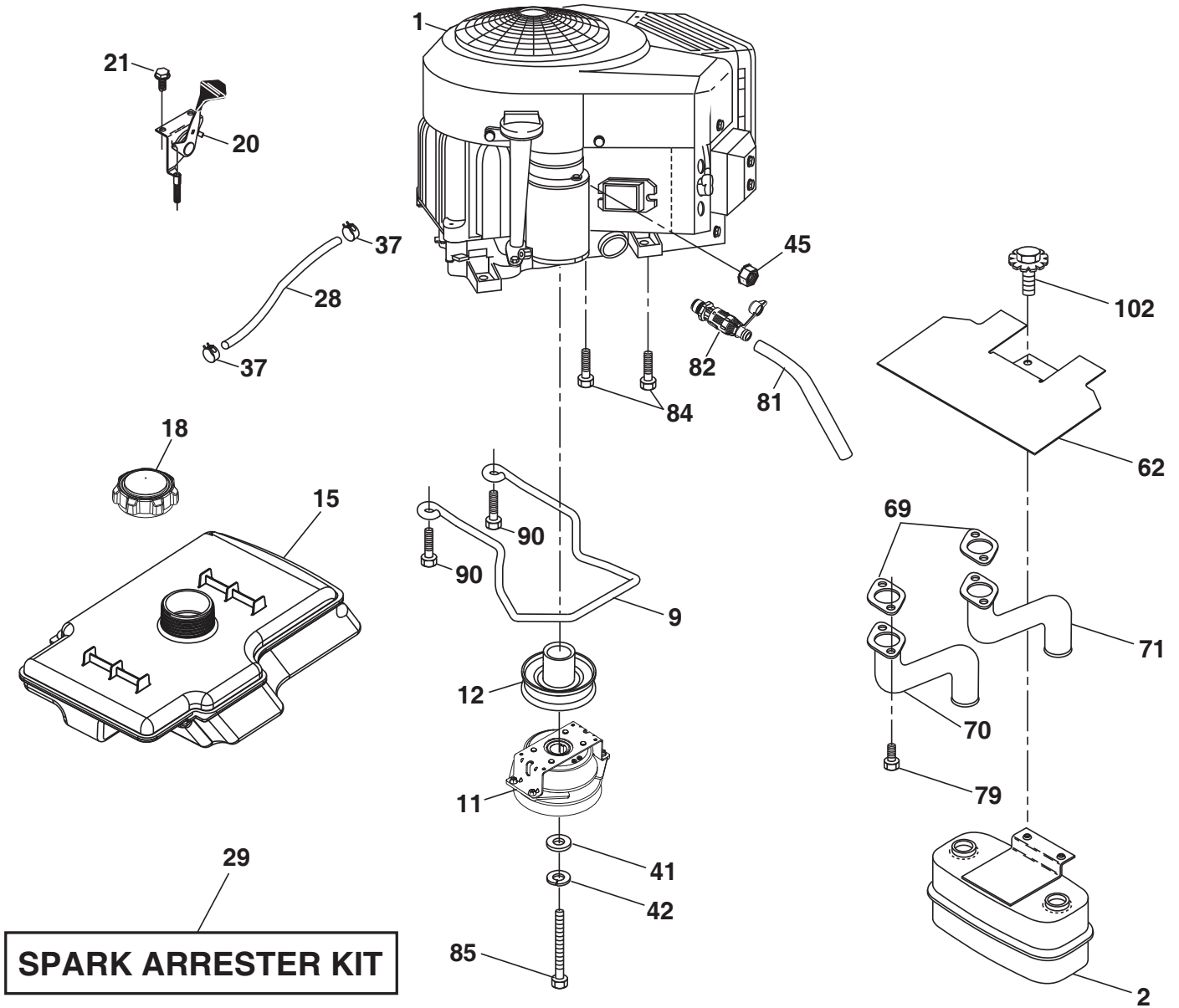

**TRACTOR - - MODEL NO. TS 246 (96041038501), PRODUCT NO. 960 41 03-85
ENGINE 24**

KEY NO.	PART NO.	DESCRIPTION
1	- - - - -	Engine B&S Model No. 44N677-0016-G1(501259501) (Order parts from engine manufacturer.)
2	589 81 87-01	Muffler
9	501 83 26-02	Keeper Belt Engine
11	587 24 16-01	Clutch Electric
12	532 40 50-97	Pulley Engine
15	532 41 81-79	Tank Fuel 2.5
18	584 24 87-01	Cap Asm
20	587 24 25-01	Control Throttle
21	532 41 63-58	Screw #10 x 0.75 BOS Thread
28	532 14 21-58	Fuel Line
29	532 13 71-80	Spark Arrester Kit
37	532 12 34-87	Clamp Hose
41	532 12 61-97	Washer 1-1/2 OD x 15/32 ID x .250
42	539 99 02-47	Washer Lock 7/16
45	873 51 04-00	Nut Keps Hex 1/4-20 unc
62	532 43 40-17	Shield Heat Muffler
69	532 16 53-91	Gasket
70	581 88 11-01	Tube Exhaust LH
71	581 88 10-01	Tube Exhaust RH
79	532 18 39-06	Screw Socket Hd 5/16-18 x 1
81	532 14 84-56	Tube Drain Oil Easy
82	532 42 82-87	Valve Oil Drain
84	817 06 06-20	Screw 3/8-16 x 1/4
85	501 60 66-01	Bolt 7/16-20 x 3.75 Gr. 5
90	817 00 06-16	Screw 3/8-16 x 1
102	817 00 05-12	Screw 5/16-18 x 3/4

NOTE: All component dimensions given in U.S. inches
1 inch = 25.4 mm

TRACTOR - - MODEL NO. TS 246 (96041038501), PRODUCT NO. 960 41 03-85
STEERING ASSEMBLY [41]

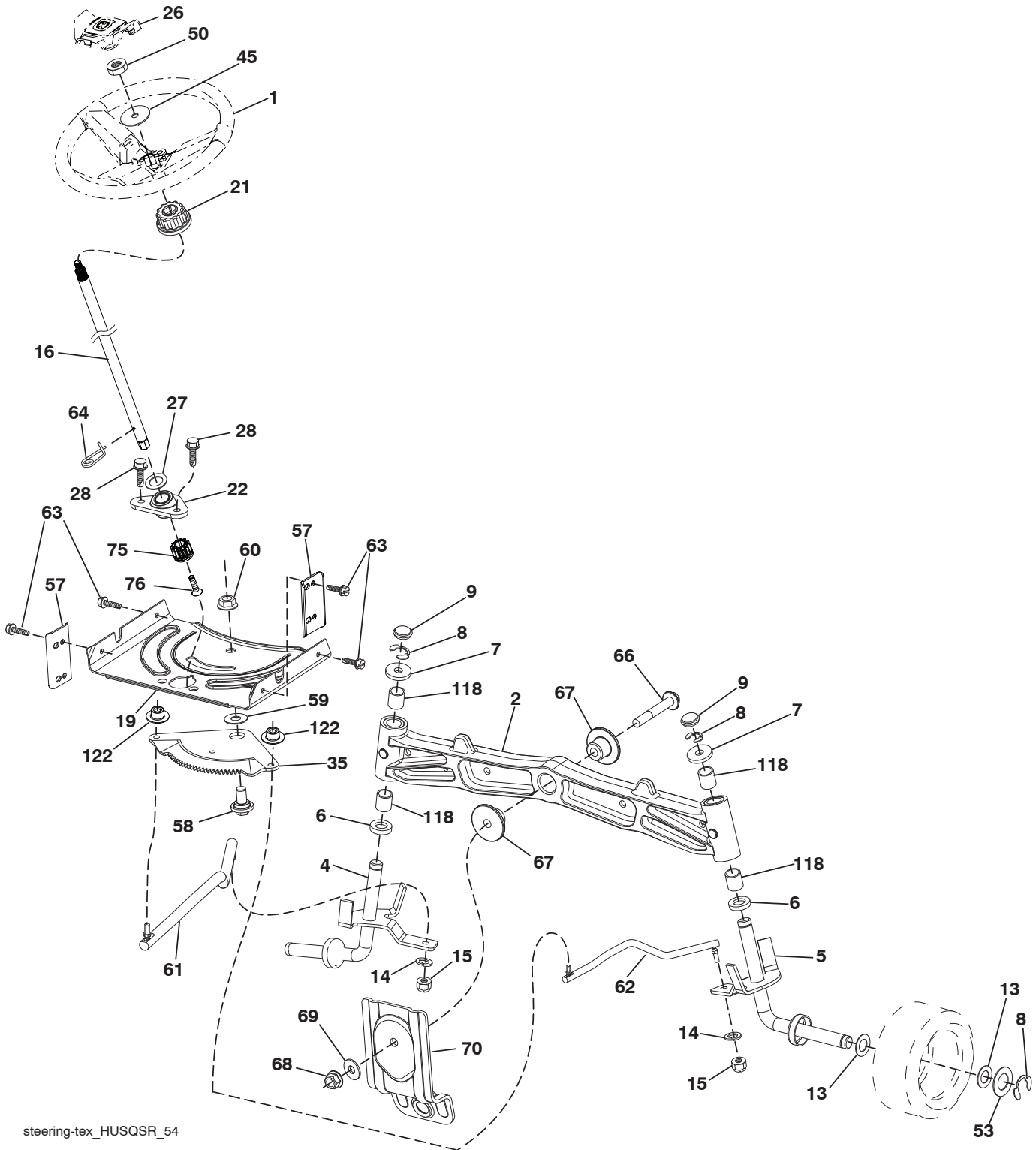

steering-tex_HUSQSR_54

**TRACTOR - - MODEL NO. TS 246 (96041038501), PRODUCT NO. 960 41 03-85
STEERING ASSEMBLY **41****

KEY NO.	PART NO.	DESCRIPTION
1	532 43 97-40	Wheel, Steering
2	532 41 35-91	Axle Cast Iron
4	532 40 30-87	Spindle Asm., LH
5	532 40 30-88	Spindle Asm., RH
6	532 12 49-31	Washer, Thrust
7	532 12 17-48	Washer 25/32 x 1-5/8 x 16 Ga.
8	812 00 00-29	Ring, Klip #T5304-75
9	532 12 12-32	Cap, Spindle
13	532 12 17-49	Washer 25/32 x 1-1/4 x 16 Ga.
14	810 04 06-00	Washer, Lock Hvy Hlcl Spr 3/8
15	873 54 06-00	Nut, Crown Lock 3/8-24 unf
16	587 01 60-02	Shaft Steering
19	532 19 47-29	Plate Steering
21	586 84 02-01	Adapter, Wheel Steering Splnd Alum
22	585 02 98-02	Bearing Subasm Shaft Steer Low
26	532 43 97-43	Insert, Wheel Steering
27	819 21 16-16	Washer 21/32 x 1 x 16 Ga.
28	817 00 06-12	Screw 3/8-16 x 3/4
35	532 19 47-32	Gear, Sector Plate
45	587 01 64-01	Washer 3/8 ID 2-3/8OD 12 Ga. PLTD
50	873 90 06-00	Nut Lock Flg. 3/8-16 unc
53	532 18 89-67	Washer Hardened .793 x 1.637 x .060
57	532 40 74-65	Bracket Upstop
58	532 19 47-47	Bolt Shoulder Sector Pivot CFM
59	532 19 47-48	Washer Thrust Sector Steering
60	873 97 10-00	Nut Flange Lock 5/8-11
61	588 79 44-01	Draglink, LH
62	588 79 45-01	Draglink, RH
63	817 00 05-12	Screw 5/16-18 x 3/4
64	532 19 98-49	Retainer Clip Spring Steering
66	871 02 07-48	Bolt Hex Fghd 7/16-14 x 3 Serr
67	532 19 47-37	Bushing PM Front Axle
68	873 90 07-00	Nut Lock Flange 7/16-14 Gr. 5
69	532 19 91-62	Washer 1.5 x .505 x .118
70	585 33 88-01	Bracket Deck Susp. Front
75	580 68 37-01	Pinion
76	580 68 36-01	Screw Head Sock
118	532 40 60-13	Bushing
122	532 44 49-62	Cap Gear Sector

NOTE: All component dimensions given in U.S. inches
1 inch = 25.4 mm

TRACTOR - - MODEL NO. TS 246 (96041038501), PRODUCT NO. 960 41 03-85
MOWER DECK 44

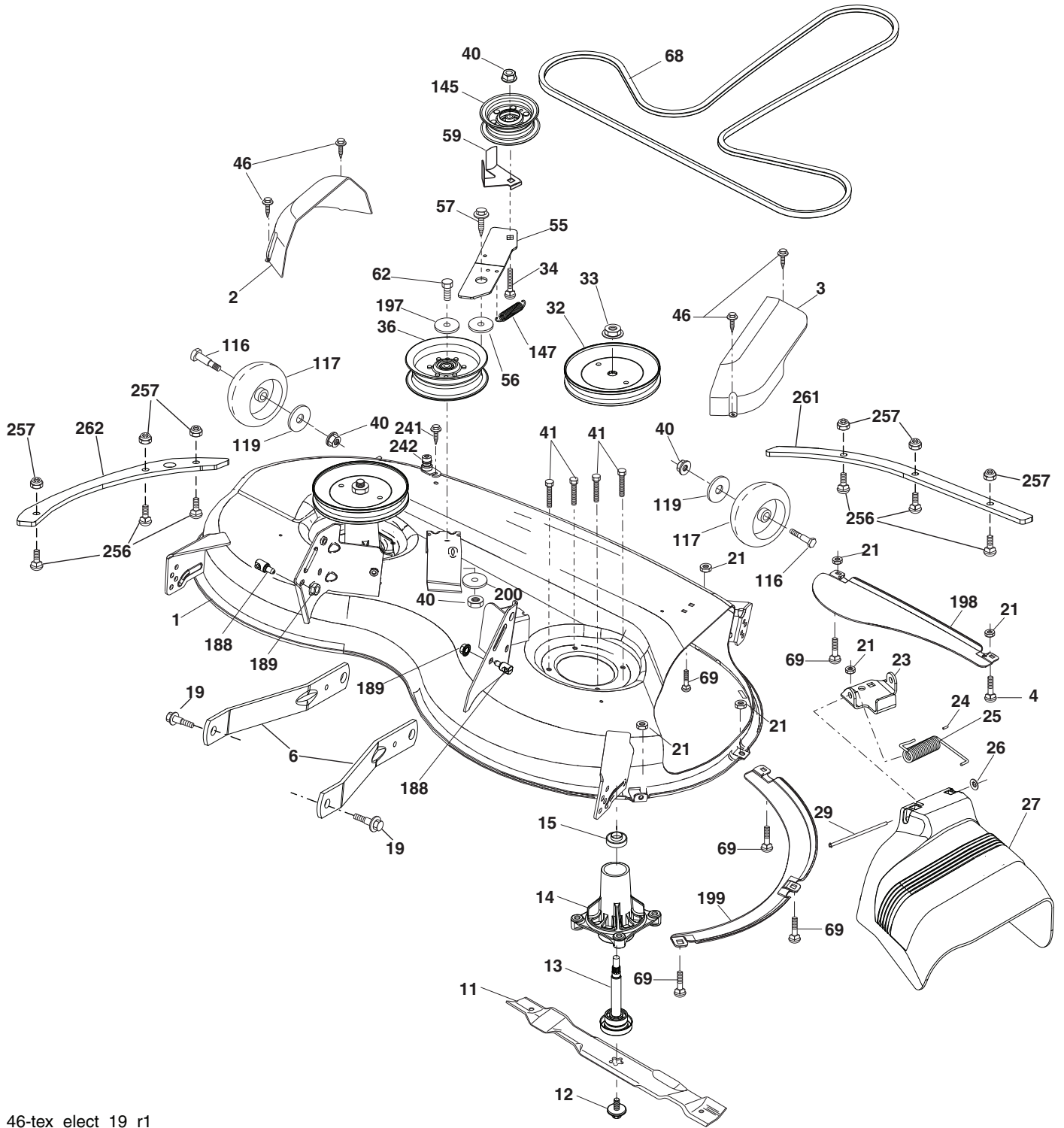

46-tex_elect_19_r1

**TRACTOR - - MODEL NO. TS 246 (96041038501), PRODUCT NO. 960 41 03-85
MOWER DECK 44**

KEY NO.	PART NO.	DESCRIPTION	KEY NO.	PART NO.	DESCRIPTION
1	589 53 53-07	Mower Housing	117	532 18 86-06	Wheel, Gauge
2	532 40 55-07	Cover Mandrel LH	119	819 12 14-14	Washer 3/8 x 7/8 x 14 Ga.
3	532 40 55-06	Cover Mandrel RH	145	532 19 31-97	Pulley Idler
4	874 76 05-12	Bolt Hex Hd 5/16-18 unc	147	532 19 72-51	Spring Return
6	532 19 51-86	Arm Suspension	188	532 19 51-61	Stud Fastener
11	532 40 53-80	Blade Mower	189	873 90 05-00	Nut Lock Hex Flange
12	584 30 93-01	Screw	197	819 13 13-12	Washer 13/32 x 13/16 x 12 Ga.
13	587 25 65-01	Shaft Asm.	198	532 40 31-49	Baffle Center Front
14	532 18 72-81	Housing, Mandrel	199	532 40 31-50	Baffle Front RH
15	585 32 39-01	Bearing	200	532 41 35-24	Washer 13/32 x 1 x 1/2 11 Ga.
19	532 19 65-39	Bolt, Shoulder	241	532 15 29-27	Screw
21	873 68 05-00	Nut	242	532 41 55-98	Washout Port
23	532 19 25-57	Bracket, Deflector	256	539 10 98-00	Carriage Bolt 1/4-20 x 1 Gr. 5
24	532 10 53-04	Cap, Sleeve	257	873 90 04-00	Nut Hex Flange 1/4-20 unc
25	532 19 70-26	Spring, Torsion, Deflector	261	589 48 18-05	Plate Reinforcement Front
26	532 11 04-52	Nut, Push	262	589 48 20-05	Plate Reinforcement Side
27	532 40 53-57	Shield, Deflector	--	587 25 33-01	Mandrel Assembly-Tall (Includes Housing (Key #14), Shaft Assembly (Key #13), and Bearing Only (Key #15) Pulley/Nut/Washer and Blade Bolt/Washers Not Included)
29	532 13 14-91	Rod, Hinge	--	589 88 53-01	Replacement Mower, Complete
32	532 19 74-73	Pulley, Mandrel			
33	532 40 02-34	Nut, Toplock, Flanged			
34	872 11 06-12	Bolt Carr Sh. 3/8-16 x 1-1/2 Gr. 5			
36	532 19 73-79	Pulley, Idler, Flat			
40	873 90 06-00	Nut, Lock Flg. 3/8-16 unc			
41	584 95 39-01	Bolt Hex Washer Head 3/8-16 x 1.19			
46	532 13 77-29	Screw			
55	532 19 72-49	Arm, Idler			
56	532 19 90-92	Spacer, Retainer			
57	817 00 06-16	Screw Hexwsh Thd 3/8-16 x 1			
59	532 14 10-43	Guard, Tuv Idler (94)			
62	874 52 06-36	Bolt 3/8-16 unc x 2-1/4 Gr. 5			
68	532 40 51-43	V-Belt			
69	872 14 05-05	Bolt			
116	532 12 48-42	Bolt, Shoulder			

NOTE: All component dimensions given in U.S. inches
1 inch = 25.4 mm

TRACTOR - - MODEL NO. TS 246 (96041038501), PRODUCT NO. 960 41 03-85
MOWER LIFT 45

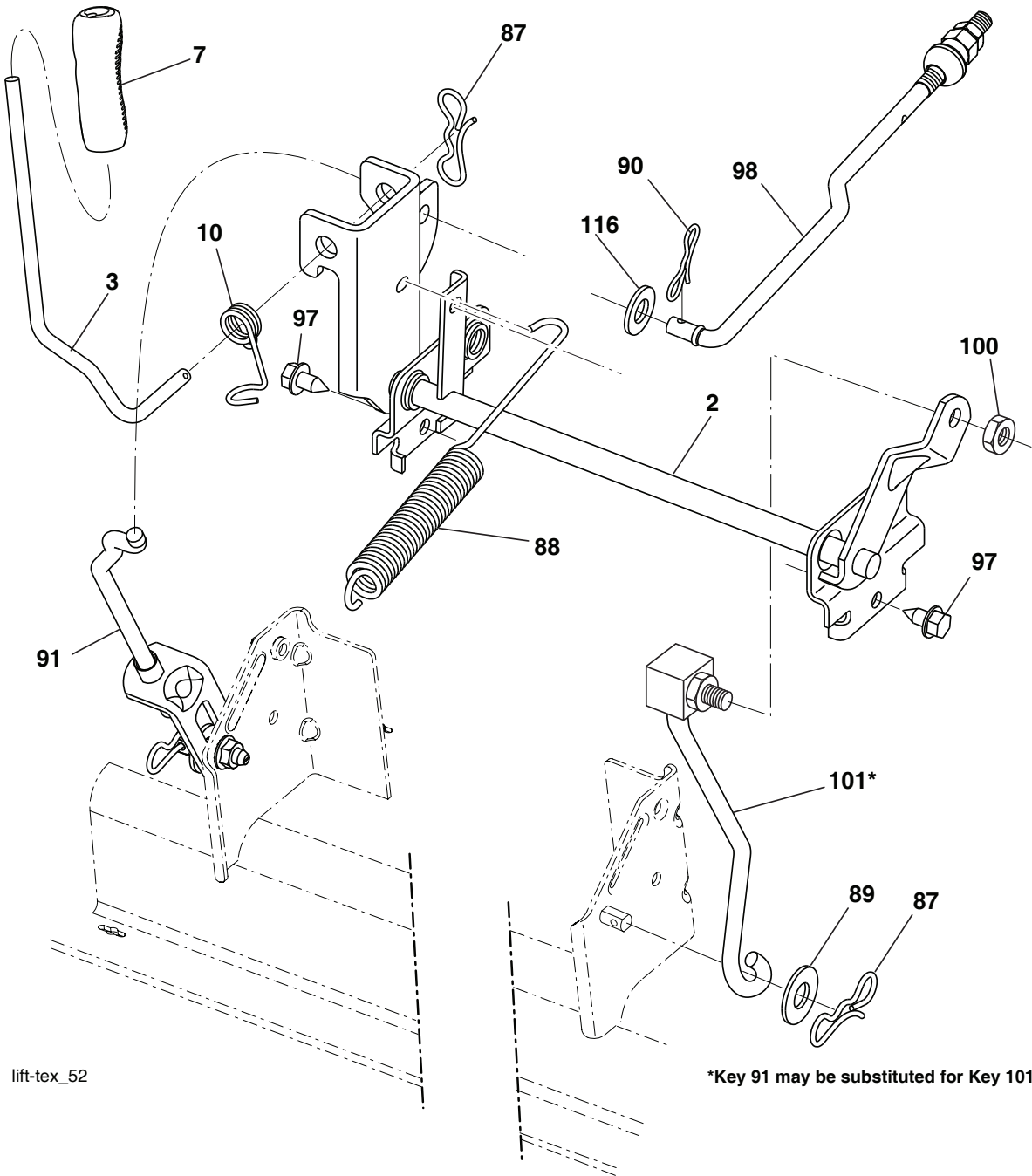

lift-tex_52

*Key 91 may be substituted for Key 101

KEY NO.	PART NO.	DESCRIPTION
2	532 42 20-27	Shaft Asm., Lift
3	532 19 52-31	Lever Asm., Lift RH
7	580 96 23-01	Grip, Lever
10	532 19 63-14	Spring Torsion
87	532 19 42-09	Pin Cotter 7/16 Bow Tie Lock
88	532 41 07-10	Spring Lift Assist
89	819 19 19-12	Washer Clear Zinc
90	532 19 42-08	Pin Cotter 5/16 Bow Tie Lock
91	532 19 51-81	Link Lift Susp Mower Rear

KEY NO.	PART NO.	DESCRIPTION
97	817 00 06-12	Screw 3/8-16 x .75 Smgml Tap/R.Z
98	532 19 52-70	Link Lift Susp. Front Mower
100	873 93 06-00	Nut Centerlock
101	532 40 70-03	Link Asm. Lift
116	819 15 15-16	Washer 15/32 x 15.16 x 16 Ga.

NOTE: All component dimensions given in U.S. inches
 1 inch = 25.4 mm

**TRACTOR - - MODEL NO. TS 246 (96041038501), PRODUCT NO. 960 41 03-85
SEAT ASSEMBLY 42**

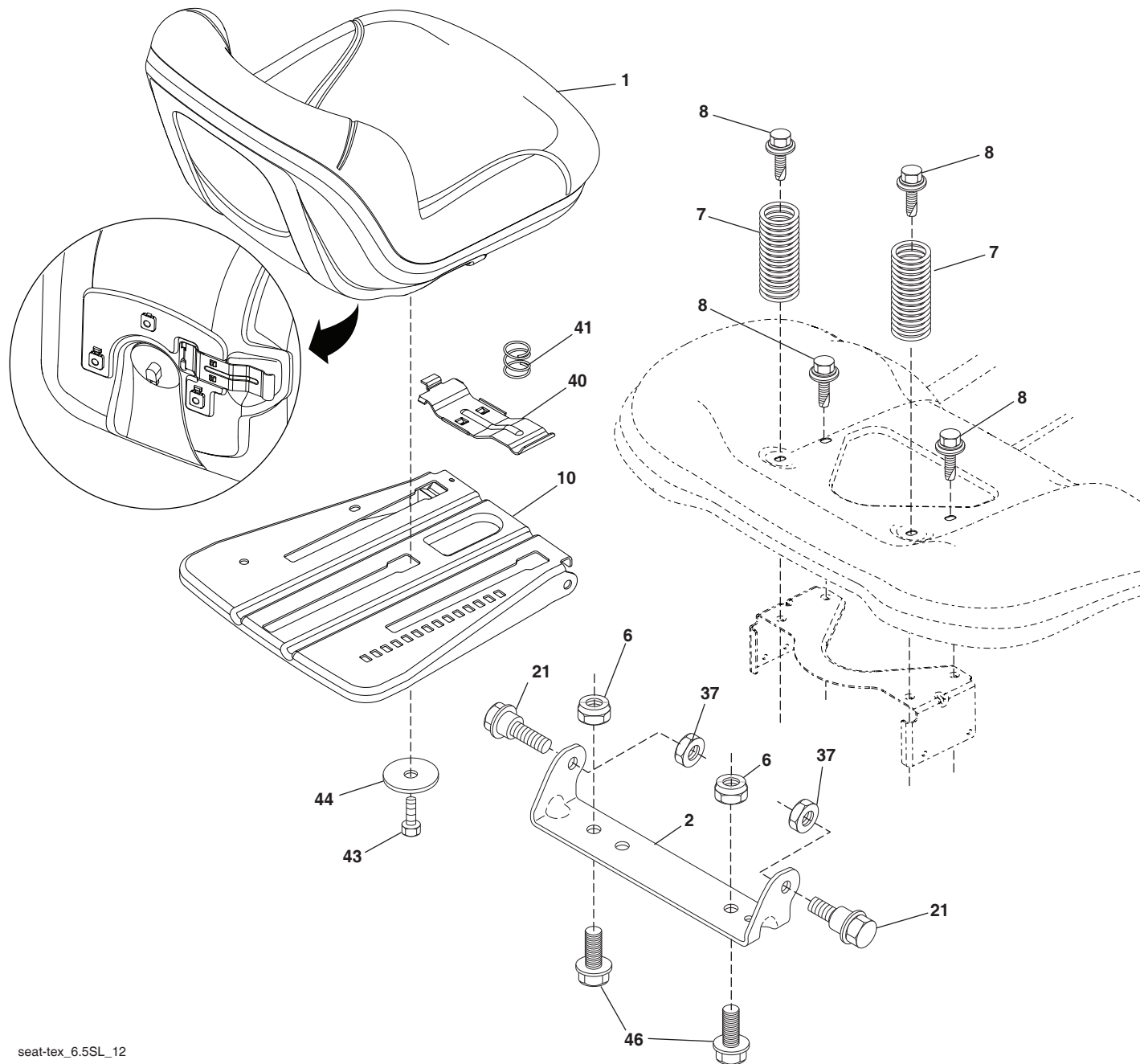

seat-tex_6.5SL_12

KEY NO.	PART NO.	DESCRIPTION
1	532 43 98-22	Seat
2	532 18 01-66	Bracket Pivot Fender
6	873 80 06-00	Nut, Lock w/Ins. 3/8-16 unc
7	589 48 35-01	Spring, Seat Cprsn
8	532 17 18-77	Bolt 5/16-18 unc x 3/4 w/Sems
10	532 19 69-77	Pan, Seat
21	587 90 78-01	Bolt, Shoulder 5/16-18 x 5/8
37	873 80 05-00	Nut, Lock 5/16-18 unc
40	532 43 98-71	Handle Slide Seat

KEY NO.	PART NO.	DESCRIPTION
41	532 19 82-00	Spring Latch Seat
43	874 76 06-12	Bolt 3/8-16 x 3/4
44	819 13 38-12	Washer 13/32 x 2-3/8 x 12 Ga.
46	588 09 04-01	Bolt 3/8-16 x 1, 1.25

NOTE: All component dimensions given in U.S. inches
1 inch = 25.4 mm

