

450X

2016

Spare parts

Ersatzteile

Pièces détachées

Reserve onderdelen

Repuestos

Reservdelar

A AUTOMOWER 450X
COVER

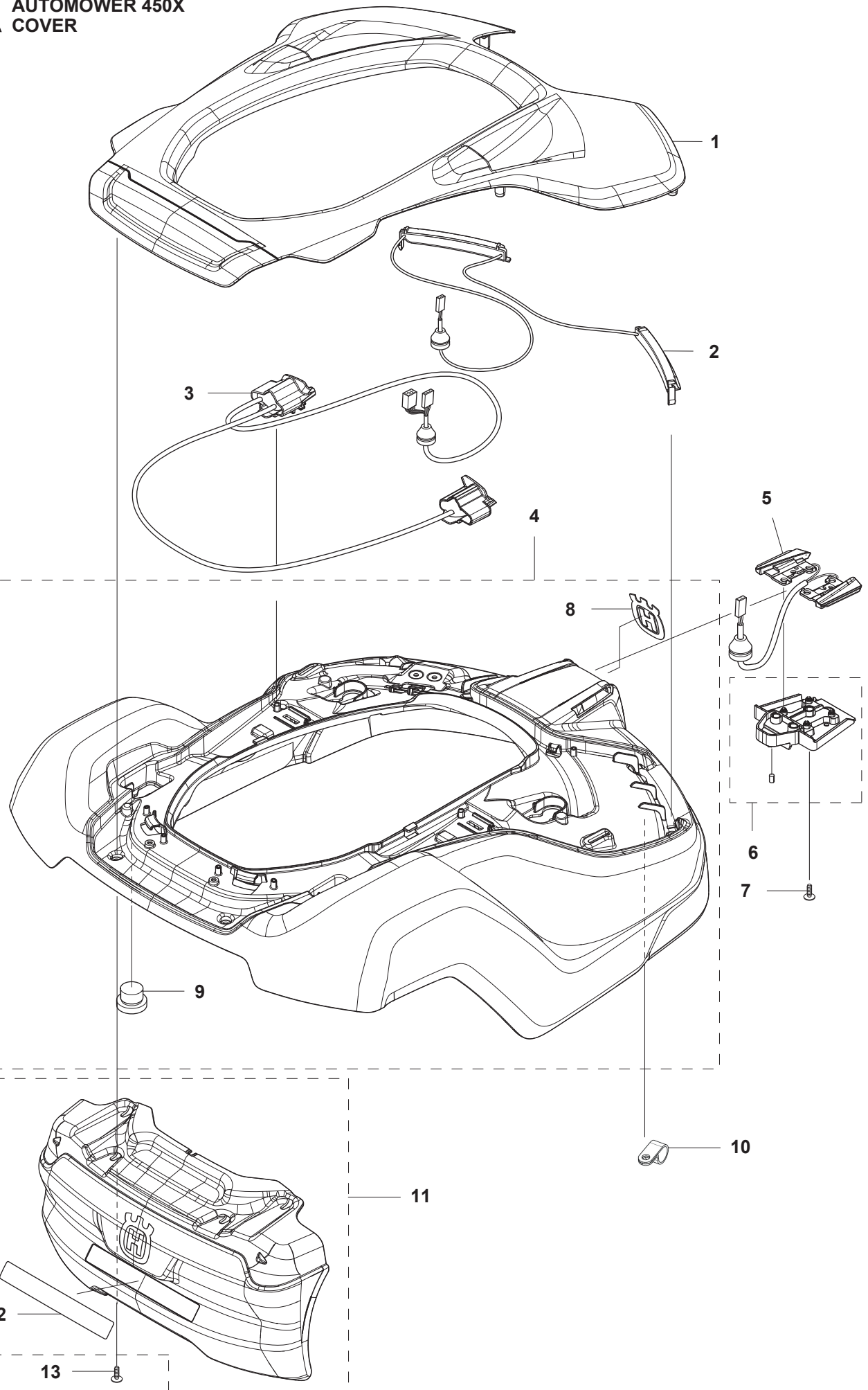

Position	Article	Quantity	Notes	Kit / Assy
1	588 79 91-01	1	Top Cover Grey	
1	588 79 91-02	1	Top Cover White	
1	588 79 91-03	1	Top Cover Orange	
2	501 06 51-01	1	LED Lights	
3	501 06 52-01	1	US-Sensors	
4	501 06 11-01	1	Body ASSY	
5	585 53 92-02	1	Charging Plate Wiring	
6	501 06 56-01	1	Holder ASSY	
7	575 54 33-14	1	Screw	
8	587 42 35-01	1	Decal Crown	4
9	580 52 68-01	4	Cap Snaploc	4
10	501 61 06-01	1	Clips	
11	501 06 50-01	1	Bumper ASSY	
12	586 35 97-01	1	Label Warning	11
13	574 45 01-01	10	Screw	

B AUTOMOWER 450X CHASSIS UPPER

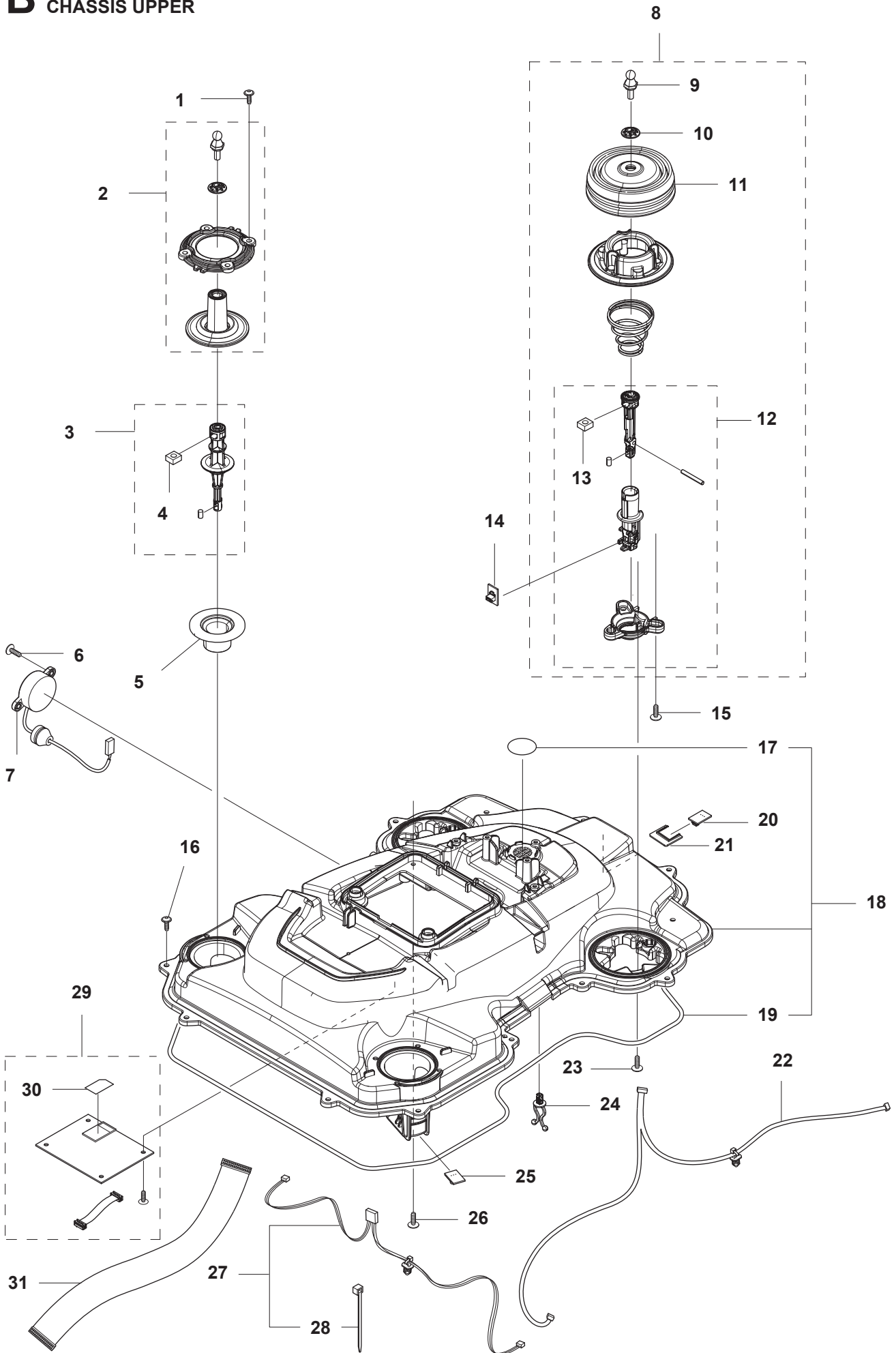

Position	Article	Quantity	Notes	Kit / Assy
1	574 45 01-01	8	Screw	
2	501 06 13-01	2	Joystick KIT Rear	
3	501 12 26-01	2	Column KIT	
4	503 22 66-01	2	Square Nut	3
5	535 14 32-01	2	Deflection Limiter	
6	575 54 33-14	2	Screw	
7	579 70 63-02	1	Buzzer	
8	581 62 09-03	2	Joystick KIT Front	
9	580 52 67-01	2	Stud	8
10	579 52 57-01	2	Washer	8
11	579 47 46-01	2	Bellows	8
12	587 44 88-02	2	Joystick ASSY	8
13	503 22 66-01	2	Square Nut	8,12
14	579 66 90-01	2	PCBA Lift Sensor	
15	575 54 33-14	6	Screw	
16	574 45 01-01	14	Screw	
17	577 75 37-01	1	Air Filter 10 pcs	
18	581 62 08-01	1	Chassis KIT	
19	581 90 32-01	1	Sealing 10 pcs Note: For warranty claims, please use part number for 1 pcs, see SB	
20	579 66 91-01	1	PCBA Collision Sensor	
21	587 83 49-01	1	Clip	
22	581 66 09-01	1	Wiring	
23	574 45 01-01	6	Screw	
24	580 68 29-01	2	Holder Twist Lock	
25	579 66 91-01	1	PCBA Collision Sensor	
26	574 45 01-01	4	Screw	
27	581 62 11-01	1	Wiring KIT	
28	900 23 87-08	2	Tie Wrap	27
29	586 66 23-02	1	Automower Connect KIT	
29	586 66 23-03	1	Automower Connect KIT (US/CA)	
30	579 77 81-02	1	SIM Card	29
31	579 70 62-01	1	Wiring	

C AUTOMOWER 450X
CENTER CONSOL

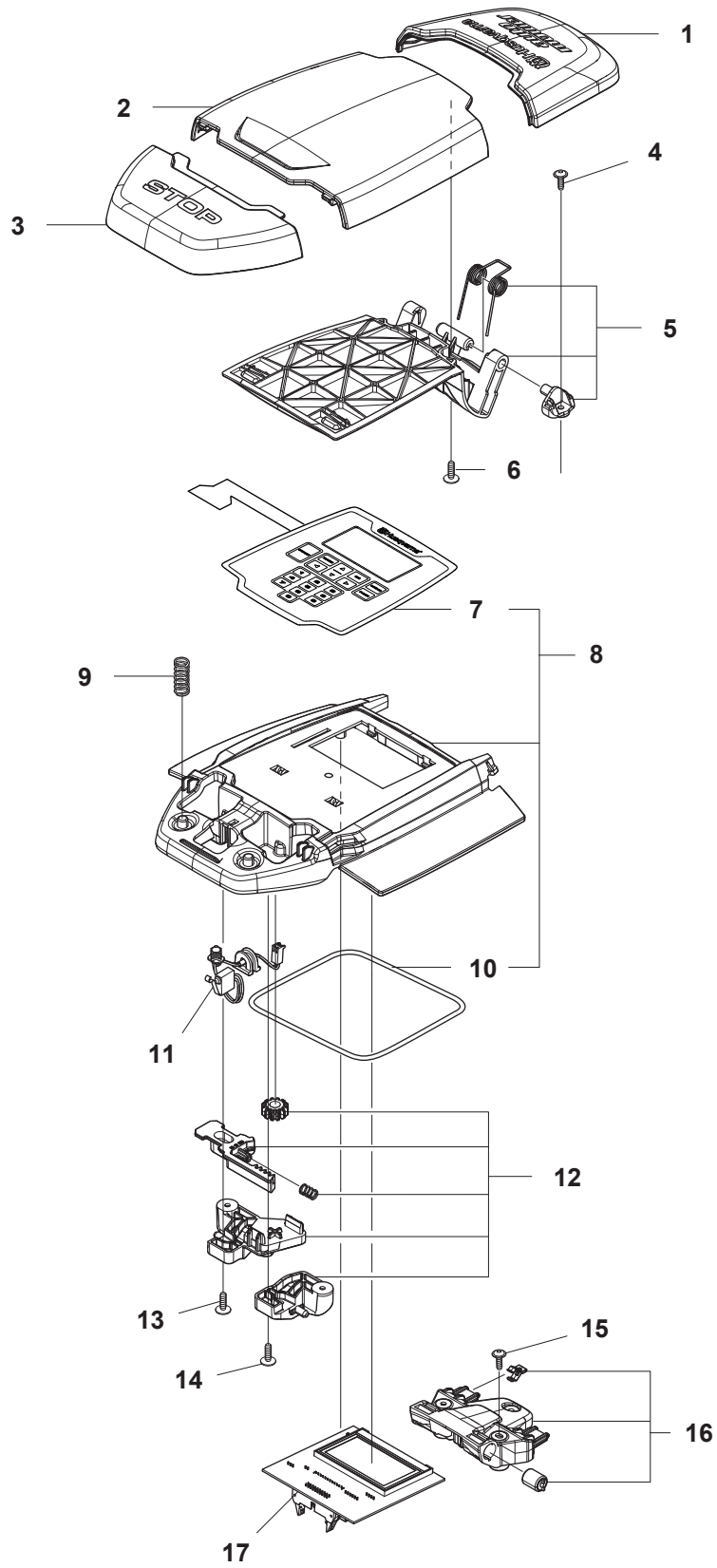

Position	Article	Quantity	Notes	Kit / Assy
1	588 79 75-04	1	Cover	
2	579 45 85-03	1	Hatch	
3	579 45 81-01	1	Stop Button	
4	575 54 33-14	2	Screw	
5	501 06 58-01	1	Hinge KIT	
6	575 54 33-14	2	Screw	
7	579 62 79-02	1	Keyboard	8
8	583 94 37-01	1	Cover ASSY	
9	535 13 01-01	2	Spring	
10	581 90 32-02	1	Sealing 10 pcs Note: For warranty claims, please use part number for 1 pcs, see SB	
11	574 48 03-02	1	Switch	
12	501 06 60-01	1	Locking Plate KIT	
13	575 54 33-14	1	Screw	
14	575 54 33-14	1	Screw	
15	575 54 33-14	3	Screw	
16	581 62 07-01	1	Support KIT	
17	588 27 59-01	1	PCBA HMI	

D AUTOMOWER 450X CHASSIS LOWER

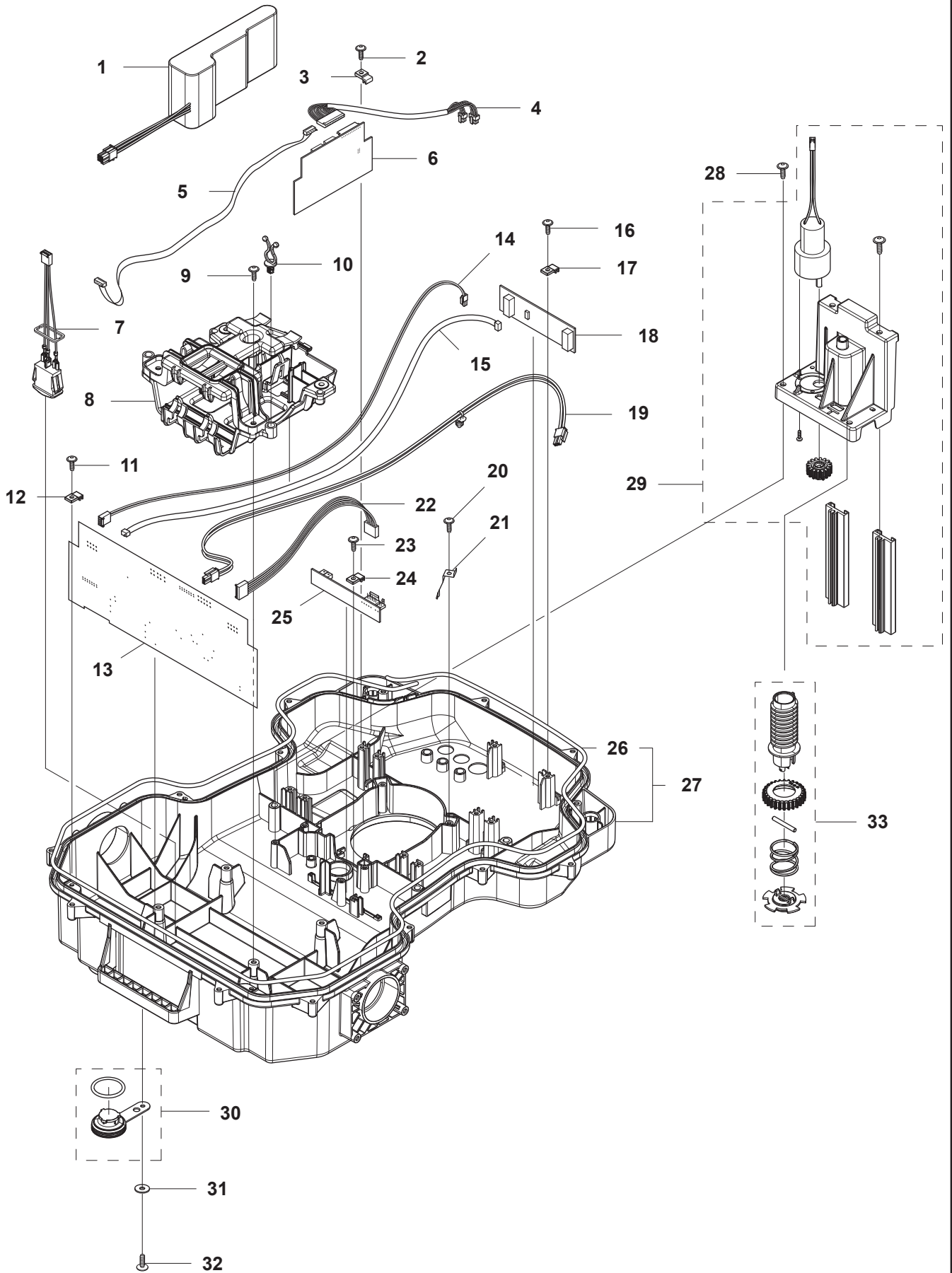

Position	Article	Quantity	Notes	Kit / Assy
1	588 14 64-01	2	Battery	
2	575 54 33-14	2	Screw	
3	579 52 94-01	2	Clamp	
4	580 61 44-01	1	US-Extension Wiring	
5	579 70 86-01	1	AUX Cable	
6	578 28 57-01	1	PCBA US	
7	579 70 87-01	1	Switch On-Off	
8	580 60 96-02	1	Holder	
9	574 45 01-01	5	Screw	
10	580 68 29-01	7	Holder Twist Lock	
11	575 54 33-14	2	Screw	
12	579 52 94-01	2	Clamp	
13	586 81 35-03	1	Main Board	
14	588 81 84-01	1	LED-Extension Wiring	
15	579 70 82-01	1	Sensor Cable	
16	575 54 33-14	2	Screw	
17	579 52 94-01	2	Clamp	
18	588 90 30-01	1	PCBA Loop Sensor	
19	580 37 07-02	1	Charging Cable	
20	575 54 33-14	2	Screw	
21	581 55 61-01	2	Spring	
22	579 70 80-01	1	Height Adjustment Wiring	
23	575 54 33-14	1	Screw	
24	579 52 94-01	1	Clamp	
25	579 72 85-02	1	PCBA Height Adjustment	
26	581 90 32-01	1	Sealing 10 pcs Note: For warranty claims, please use part number for 1 pcs, see SB	
27	583 94 45-02	1	Chassis KIT	
28	575 54 33-14	4	Screw	
29	501 06 83-01	1	Motor ASSY	
30	581 62 12-02	1	Plug KIT	
31	734 11 37-41	1	Washer	
32	574 45 01-01	1	Screw	
33	581 62 16-01	1	Gear KIT	

E AUTOMOWER 450X WHEELS & TIRES

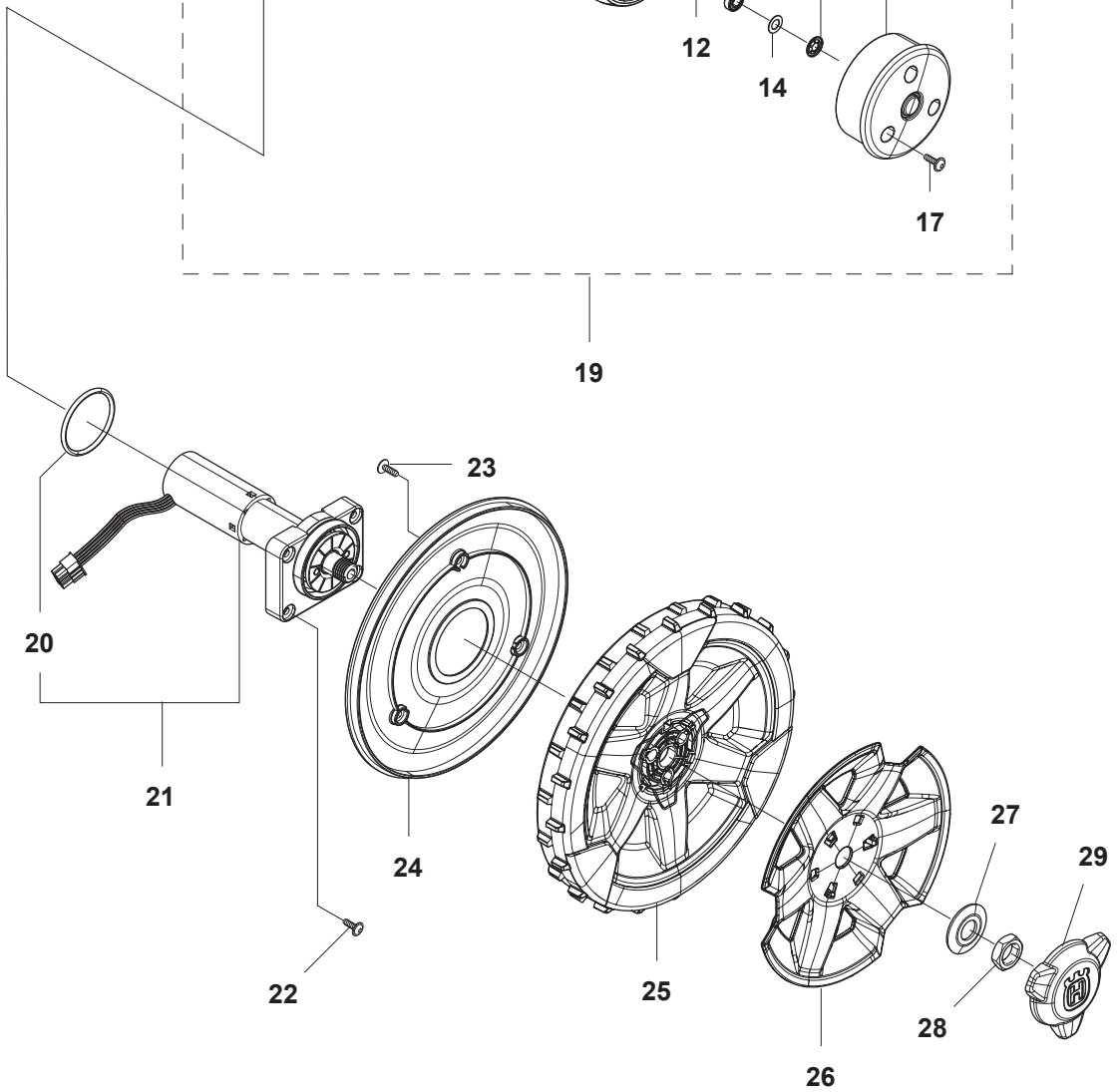
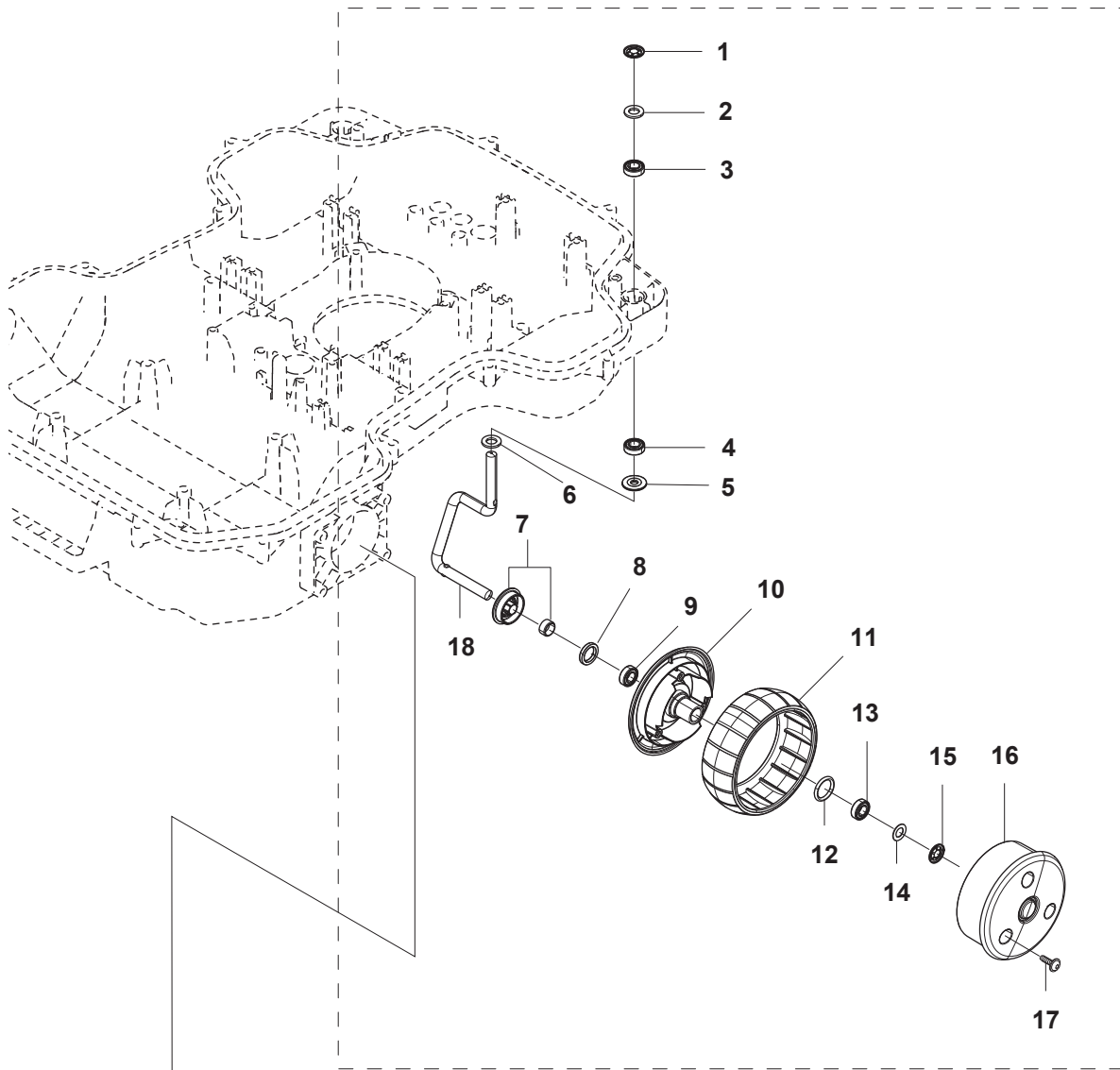

Position	Article	Quantity	Notes	Kit / Assy
1	576 01 93-02	2	Lock Washer	19
2	580 76 46-01	2	Washer	19
3	580 60 51-01	2	Ball Bearing	19
4	580 60 51-01	2	Ball Bearing	19
5	535 08 78-03	2	Washer	19
6	580 76 46-01	2	Washer	19
7	581 62 15-01	2	Sheild KIT	19
8	580 48 71-01	2	Sealing	19
9	580 60 51-01	2	Ball Bearing	19
10	579 45 71-01	2	Wheel Inside	19
11	574 44 98-01	2	Tire	19
12	580 44 51-01	2	O-Ring	19
13	580 60 51-01	2	Ball Bearing	19
14	580 76 46-01	2	Washer	19
15	576 01 93-02	2	Lock Washer	19
16	579 45 72-01	2	Wheel Outside	19
17	575 54 33-14	6	Screw	19
18	580 33 61-01	2	Spindle	19
19	581 62 14-01	2	Front Wheel KIT	
20	580 44 39-02	2	O-Ring	21
21	581 62 13-02	2	Wheel Motor ASSY	
22	574 45 01-01	8	Screw	
23	575 54 33-14	6	Screw	
24	579 50 56-02	2	Cover	
25	579 50 60-03	2	Rear Wheel	
26	579 50 57-01	2	Wheel Cover	
27	586 21 06-01	2	Spring Washer	
28	731 43 24-01	2	Thin Nut	
29	579 50 55-02	2	Hub Cap	

F AUTOMOWER 450X
BLADE MOTOR & CUTTING EQUIPMENT

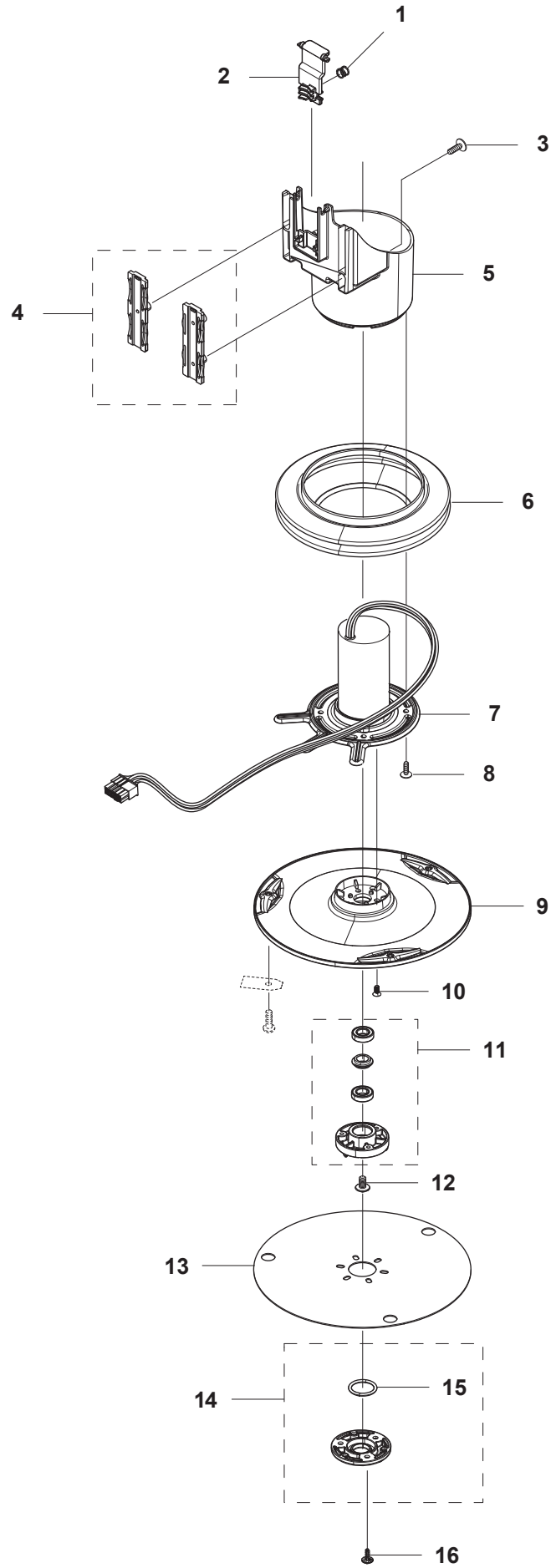

Position	Article	Quantity	Notes	Kit / Assy
1	580 62 44-01	1	Spring	
2	579 56 46-01	1	Link	
3	575 54 33-14	3	Screw	
4	581 62 18-01	1	Bearing KIT	
5	579 56 45-01	1	Housing	
6	579 66 64-03	1	Bellows	
7	587 38 14-01	1	Cutting Motor ASSY	
8	575 54 33-14	4	Screw	
9	587 37 81-01	1	Cutting Disc	
10	535 13 05-01	3	Screw	
11	588 42 17-01	1	Bearing Housing ASSY	
12	535 07 60-01	1	Screw	
13	587 37 80-01	1	Skid Plate	
14	587 44 96-01	1	Bearing Cover ASSY	
15	585 29 75-01	1	O-Ring	14
16	575 54 33-14	3	Screw	

G AUTOMOWER 450X
CHARGING STATION

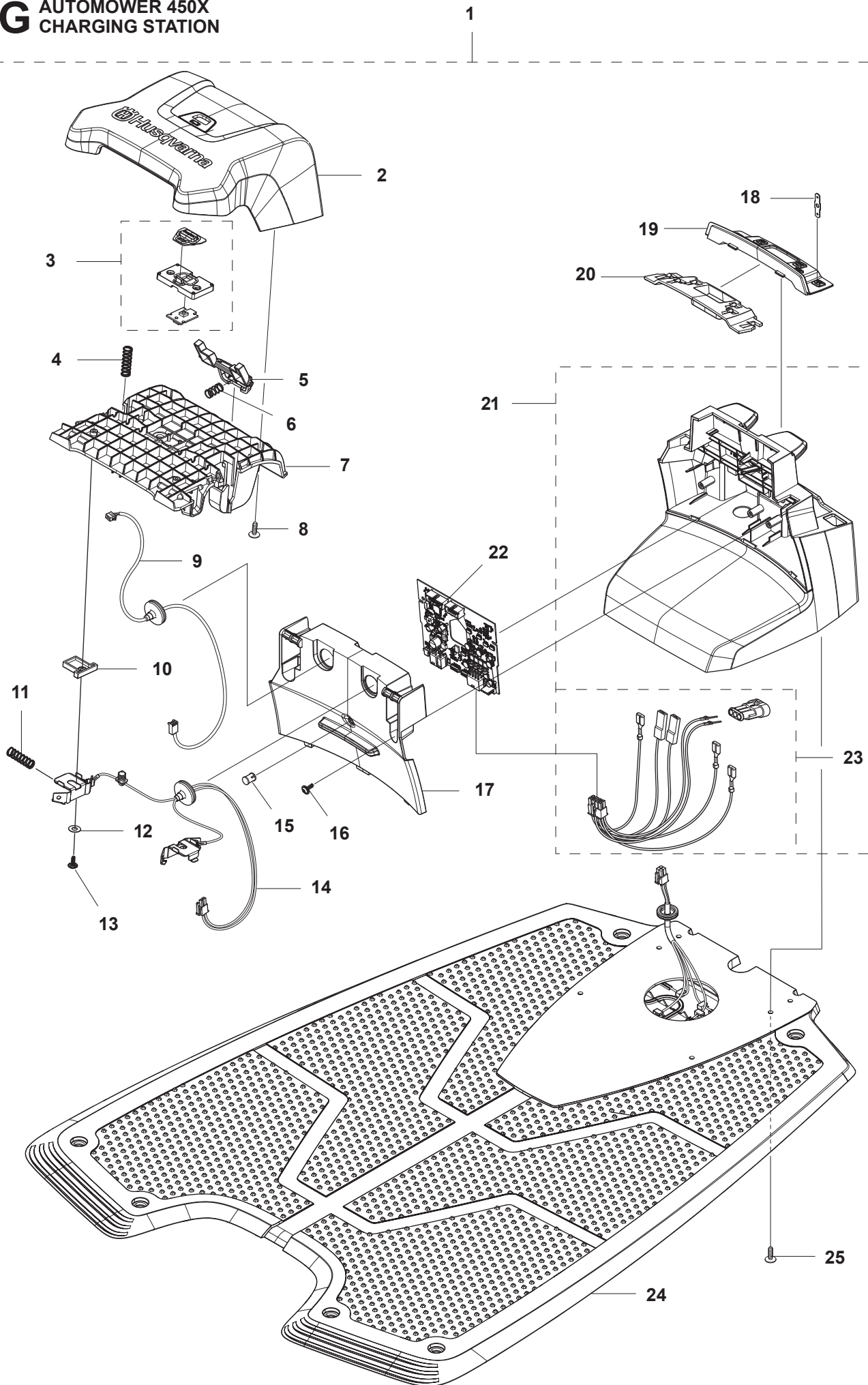

Position	Article	Quantity	Notes	Kit / Assy
1	580 76 55-03	1	Charging Station	
2	579 44 82-04	1	Cap	
3	501 06 59-01	1	Home Button KIT	
4	580 51 14-01	2	Spring	
5	579 46 24-02	1	Button - Release	
6	574 48 70-01	1	Spring	
7	579 45 80-04	1	Frame	
8	575 54 33-14	4	Screw	
9	579 70 83-01	1	Home Button Wiring	
10	579 46 05-01	2	Distance	
11	580 51 14-01	2	Spring	
12	734 11 37-41	2	Washer	
13	575 54 33-14	2	Screw	
14	585 53 95-01	1	Loom Charging Contact	
15	535 12 87-02	1	Lens	
16	575 54 33-14	2	Screw	
17	579 45 97-03	1	Lid	
18	580 50 41-01	5	Terminal	
19	579 45 98-03	1	Panel	
20	579 45 99-01	1	Holder	
21	588 18 88-01	1	Housing KIT	
22	579 56 55-04	1	PCBA Charging Station	
23	588 47 89-01	1	Wiring CS	21
24	575 23 16-02	1	Charging Plate	
25	575 54 33-14	4	Screw	

H AUTOMOWER 450X INSTALLATION ACCESSORIES

1

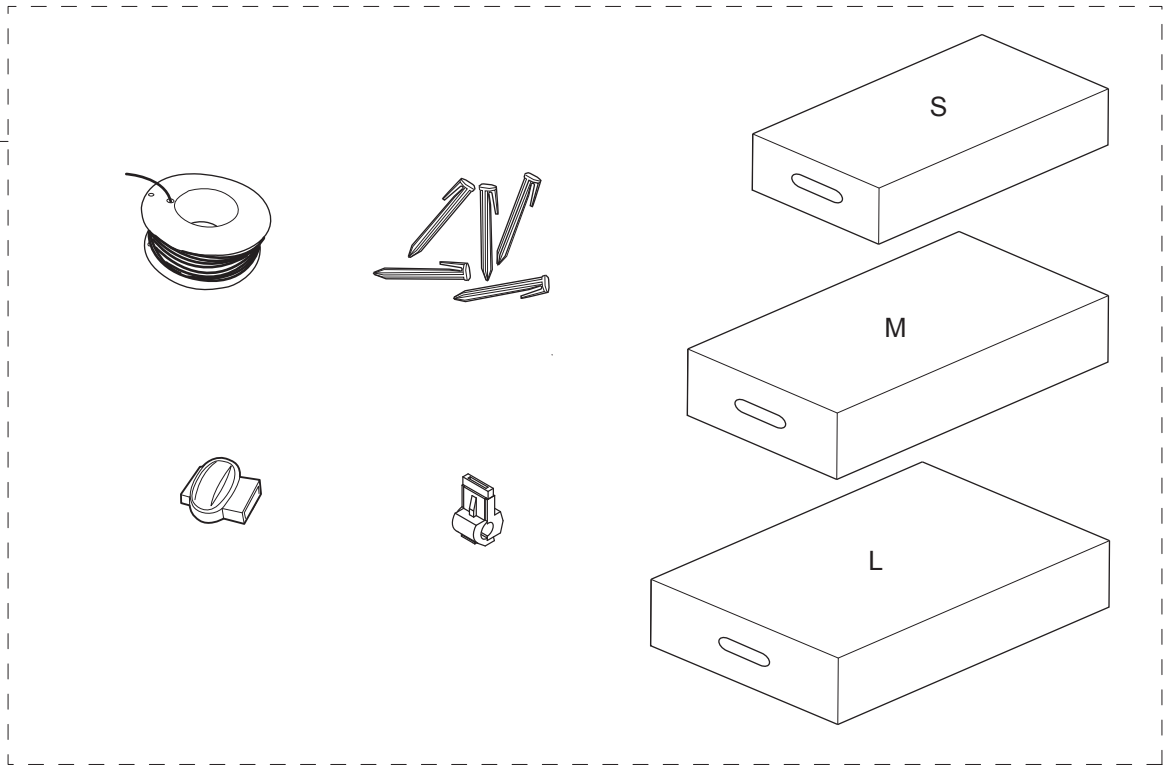

2



3

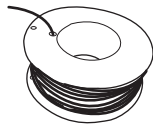

5

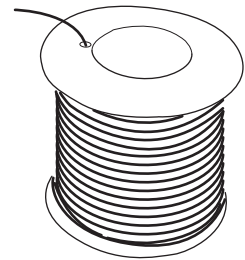

8



4



6

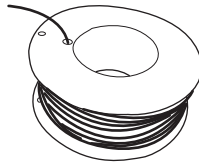

7

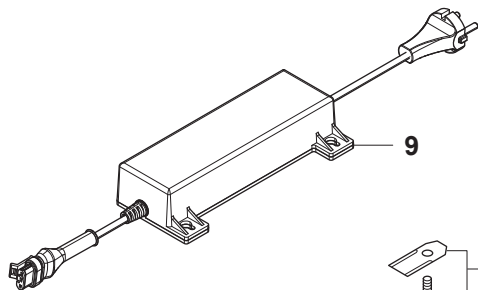

9



10

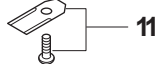

11



12

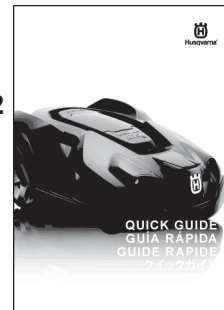

13

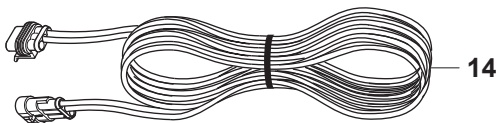

14

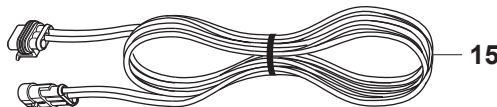

15

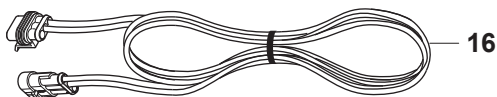

16

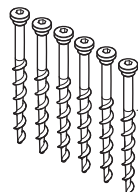

17

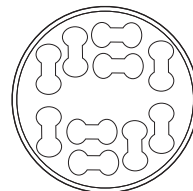

18



19

Position	Article	Quantity	Notes	Kit / Assy
1	967 62 36-01	1	Installation KIT S: Wire (150 m), Staples (300 pcs), Connectors (3 pcs), Couplers (5 pcs)	
1	967 62 36-02	1	Installation KIT M: Wire (250 m), Staples (400 pcs), Connectors (3 pcs), Couplers (5 pcs)	
1	967 62 36-03	1	Installation KIT L: Wire (400 m), Staples (600 pcs), Connectors (5 pcs), Couplers (5 pcs)	
2	535 12 90-01	1	Loop Wire Connector	1
2	577 86 48-01	1	Loop Wire Connector, Blister Pack, 5 pcs	
3	501 98 02-01	1	Coupler	1
3	577 86 47-01	1	Coupler, Blister pack, 5 pcs	
3	501 98 02-03	1	Coupler, 100 pcs	
4	577 86 42-01	1	Staple, 85 mm, Blister pack, 100 pcs	
4	583 97 34-01	1	Staple, 85 mm, 100 pcs	1
5	580 66 20-02	1	Wire (150 m)	1
5	577 86 43-01	1	Wire, Blister pack, (150 m)	
6	580 66 20-01	1	Wire (250 m)	1
7	522 91 41-01	1	Wire (500 m, Ø3.4 mm)	
8	580 66 20-04	1	Wire (800 m)	
9	501 57 51-01	1	Power Supply Unit (EU)	
9	501 57 51-02	1	Power Supply Unit (UK/IRL)	
9	501 57 51-03	1	Power Supply Unit (CH)	
9	586 81 22-04	1	Power Supply Unit (US/MX)	
9	586 81 22-05	1	Power Supply Unit (AU/NZ)	
10	544 17 75-01	1	Measuring Tape	
11	577 86 46-02	1	Long Life Safety Blade, Blister Pack, 9 pcs	
11	577 60 65-04	1	Long Life Safety Blade, 45 pcs	
11	577 60 66-03	1	Long Life Safety Blade, 300 pcs	
12	115 78 66-01	1	Operator's Manual, Swedish	
12	115 78 66-06	1	Operator's Manual, Danish	
12	115 78 66-11	1	Operator's Manual, Finnish	
12	115 78 66-21	1	Operator's Manual, Norwegian	
12	115 78 66-26	1	Operator's Manual, English	
12	115 78 66-31	1	Operator's Manual, French	
12	115 78 66-36	1	Operator's Manual, Dutch	
12	115 78 66-41	1	Operator's Manual, Italian	
12	115 78 66-46	1	Operator's Manual, Spanish	
12	115 78 66-51	1	Operator's Manual, German	
12	115 78 66-56	1	Operator's Manual, Russian	
12	115 78 66-58	1	Operator's Manual, Hungarian	
12	115 78 66-59	1	Operator's Manual, Portuguese	
12	115 78 66-61	1	Operator's Manual, Polish	
12	115 78 66-62	1	Operator's Manual, Romanian	
12	115 78 66-63	1	Operator's Manual, Estonian	
12	115 78 66-64	1	Operator's Manual, Latvian	
12	115 78 66-65	1	Operator's Manual, Lithuanian	
12	115 78 66-68	1	Operator's Manual, Slovakian	
12	115 78 66-71	1	Operator's Manual, Greek	
12	115 78 66-76	1	Operator's Manual, Turkish	
12	115 78 66-79	1	Operator's Manual, Japanese	
12	115 78 66-81	1	Operator's Manual, Croatian	
12	115 78 66-84	1	Operator's Manual, Slovenian	
12	115 78 66-90	1	Operator's Manual, Czech	
12	115 78 66-96	1	Operator's Manual, Spanish (USA)	
13	115 78 67-10	1	Quick Guide, Swedish, Danish, Norwegian, Finnish	
13	115 78 67-20	1	Quick Guide, German, French, Dutch, Slovenian	

13	115 78 67-30	1	Quick Guide, Spanish, Portuguese, Italian, English	
13	115 78 67-38	1	Quick Guide, English, Spanish, French, Japanese (incl. US/CA)	
13	115 78 67-39	1	Quick Guide, German, French, Italian, English	
13	115 78 67-40	1	Quick Guide, Russian, Estonian, Latvian, Lithuanian	
13	115 78 67-50	1	Quick Guide, Czech, Slovak, Polish, Hungarian	
13	115 78 67-93	1	Quick Guide, Croatian, Turkish, Romanian, Greek	
14	588 76 50-01	1	Low Voltage Cable 20 m	
15	588 76 50-02	1	Low Voltage Cable 10 m	
16	588 76 50-03	1	Low Voltage Cable 3 m	
17	575 23 86-01	1	Screw KIT, 6 pcs	
17	577 86 49-01	1	Screw KIT, Blister Pack, 3 pcs	
18	586 27 79-01	1	Sticker Cable markers, 10 pcs	
19	579 57 12-01	1	Label Alarm	

AUTOMOWER 450X ACCESSORIES

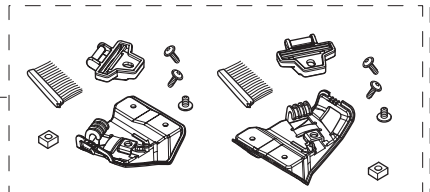
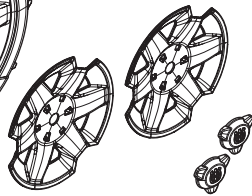
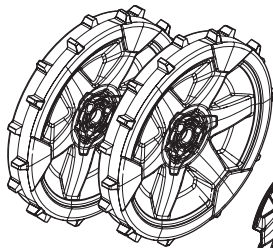
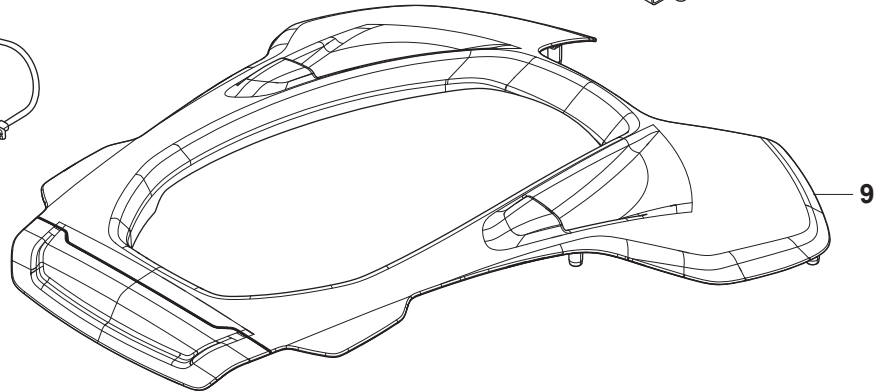
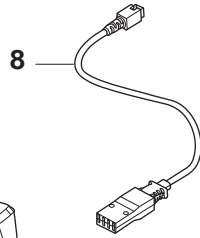
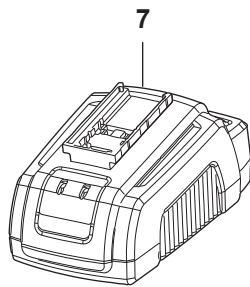
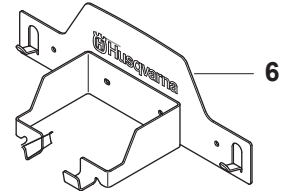
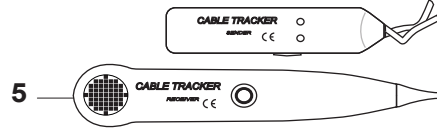

11

12

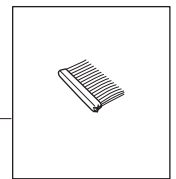

13

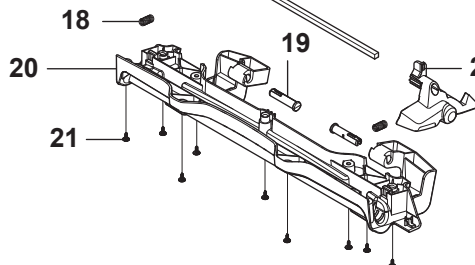
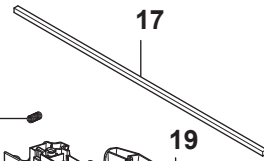
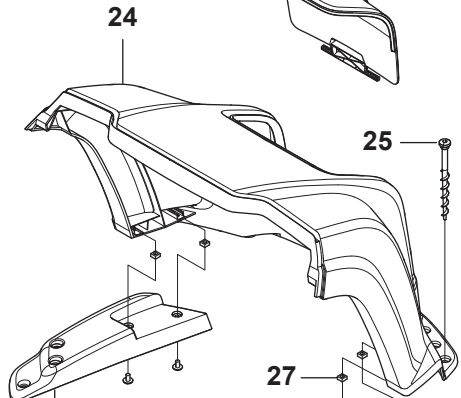
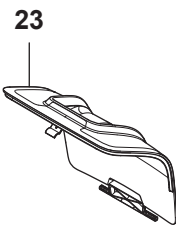
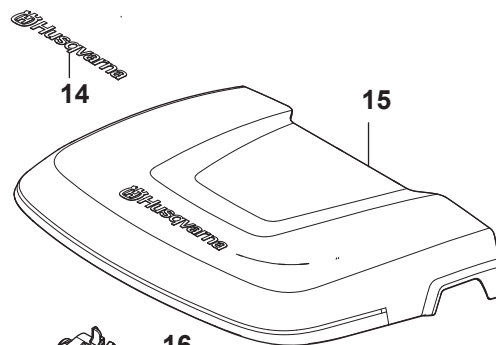

25

27

28
29

Position	Article	Quantity	Notes	Kit / Assy
1	577 85 81-03	1	DVD Autocheck EXP	
2	577 51 81-02	1	Service Cable (USB)	
3	522 91 67-01	1	Bag	
4	584 90 22-01	1	Warranty Seal 10 pcs Note: For warranty claims, please use part number for 1 pcs, see SB	
5	577 60 68-01	1	Interruption Detector	
6	585 01 97-02	1	Wall Hanger	
7	588 40 84-01	1	Quick Charger with Battery Test	
8	588 20 26-01	1	Cable Quick Charger	
9	588 79 91-01	1	Top Cover Grey	
9	588 79 91-02	1	Top Cover White	
9	588 79 91-03	1	Top Cover Orange	
10	581 90 31-02	1	Brush KIT incl. Brush, 6 pcs	11
11	581 88 97-02	1	Rear Wheel KIT incl. Brush KIT	
12	581 98 20-02	1	Brush, 6 pcs	10, 11
13	585 01 94-01	1	House KIT	
14	577 46 90-01	1	Decal	13
15	586 88 58-01	1	Cover Lid	13
16	585 32 40-02	1	Handle Left	13
17	585 32 41-01	1	Steel Rod	13
18	580 51 14-01	2	Spring	13
19	585 34 15-01	2	Hinge Pin	13
20	585 34 16-01	1	Beam	13
21	575 54 33-14	9	Screw	13
22	585 32 40-01	1	Handle Right	13
23	585 32 36-01	1	Hatch	13
24	585 32 34-01	1	Cover Base	13
25	575 23 86-01	1	Screw KIT, 6 pcs	13
26	585 32 38-02	1	Support Base Left	13
27	503 22 66-01	4	Square Nut	13
28	585 32 38-01	1	Support Base Right	13
29	535 12 93-03	4	Screw	13