

ILLUSTRATED PARTS LIST

MFG. ID NO. 96051013701

CUSTOMER CATALOG NO. TC 238

PRODUCT NO. 960 51 01-37

47

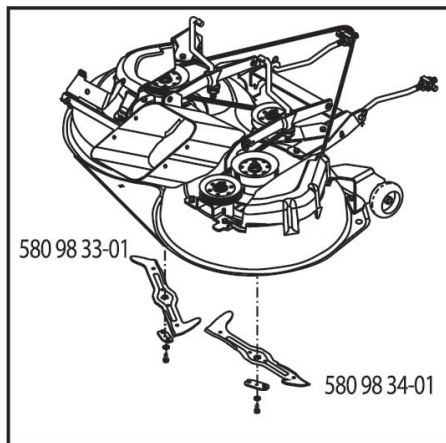
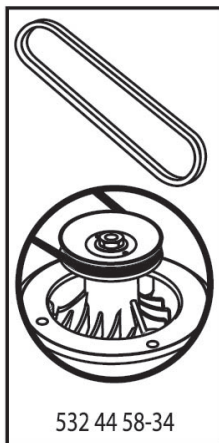
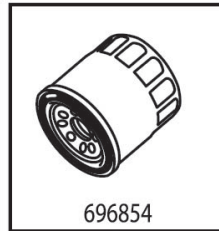
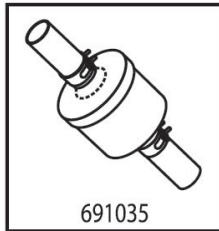
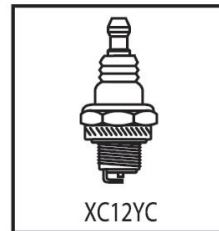
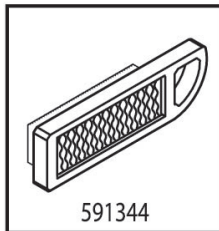

588710101

**TRACTOR - - MODEL NO. TC 238 (96051013701), PRODUCT NO. 960 51 01-37
DECALS 27**

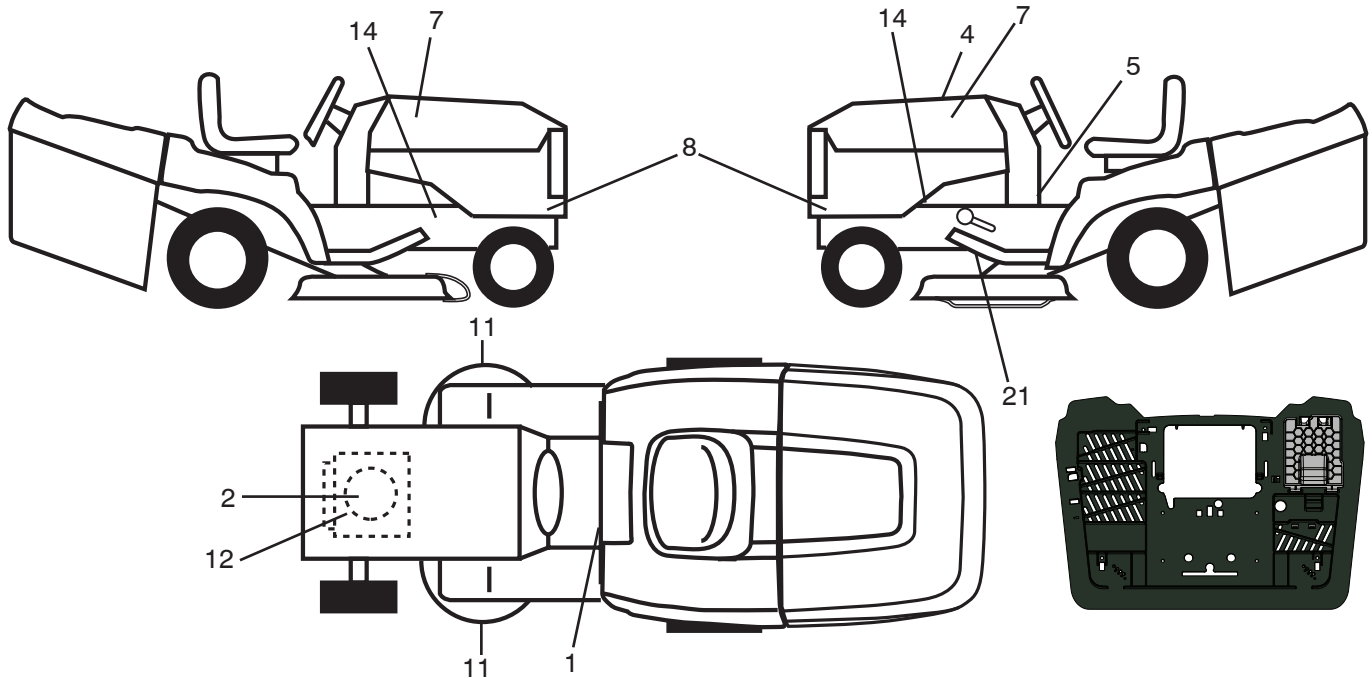

KEY NO.	PART NO.	DESCRIPTION
1	586 34 95-01	Decal, FNDR
2	581 57 97-01	Decal, Warning Eng. Sym.
4	588 71 01-01	Decal, Replacement
5	581 57 84-01	Decal, Lower Dash
7	581 62 73-01	Decal, Hood
8	588 72 58-01	Decal, Side Panel
11	581 57 91-01	Decal, Mower Cut Finger Symbol
12	586 00 05-01	Decal, Engine B&S

KEY NO.	PART NO.	DESCRIPTION
14	581 57 96-01	Decal, Chassis Hot Muffler
21	532 44 11-89	Decal, Belt Schematic
--	501 08 26-01	Decal, ECM
--	532 44 46-19	Decal, Bypass
--	532 44 14-09	Pad Footrest LH
--	532 44 14-10	Pad Footrest RH
--	582 17 70-01	Manual Operator's English

WHEELS AND TIRES

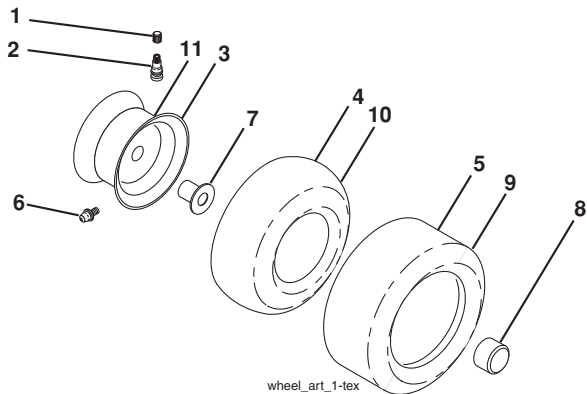

KEY NO.	PART NO.	DESCRIPTION
1	532 05 91-92	Cap Valve Tire
2	532 06 51-39	Stem Valve
3	532 13 83-36	Rim Front
4	532 05 99-04	Tube Front (Service Item Only)
5	532 10 62-22	Tire Front 15 x 6-6
6	532 12 49-57	Fitting Grease (Front Wheel Only)
7	532 12 49-59	Bearing Flange (Front Wheel Only)
8	532 17 50-39	Cap Axle Blk 1 50 x 1 00
9	532 42 05-31	Tire Rear 18 x 9.5-8
10	532 12 49-26	Tube Rear (Service Item Only)
11	532 13 83-37	Rim Asm 8" Rear
--	532 14 43-34	Sealant, Tire (10 oz. Tube)

NOTE: All component dimensions given in U.S. inches
1 inch = 25.4 mm

TRACTOR - - MODEL NO. TC 238 (96051013701), PRODUCT NO. 960 51 01-37

SCHEMATIC 38

SCH31

SMART IGNITION SWITCH (S.I.S.)

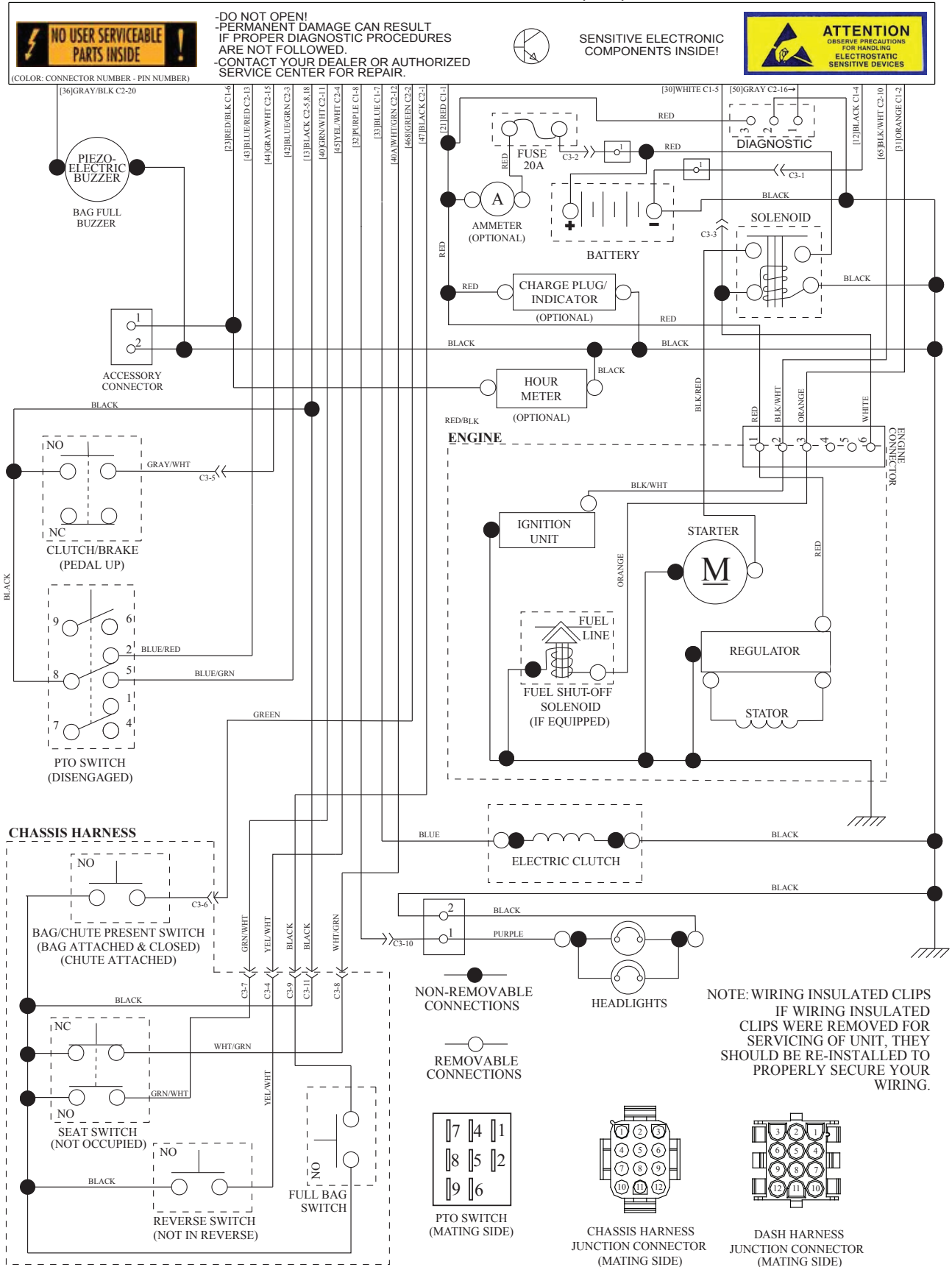

TRACTOR - - MODEL NO. TC 238 (96051013701), PRODUCT NO. 960 51 01-37
ELECTRICAL **32**

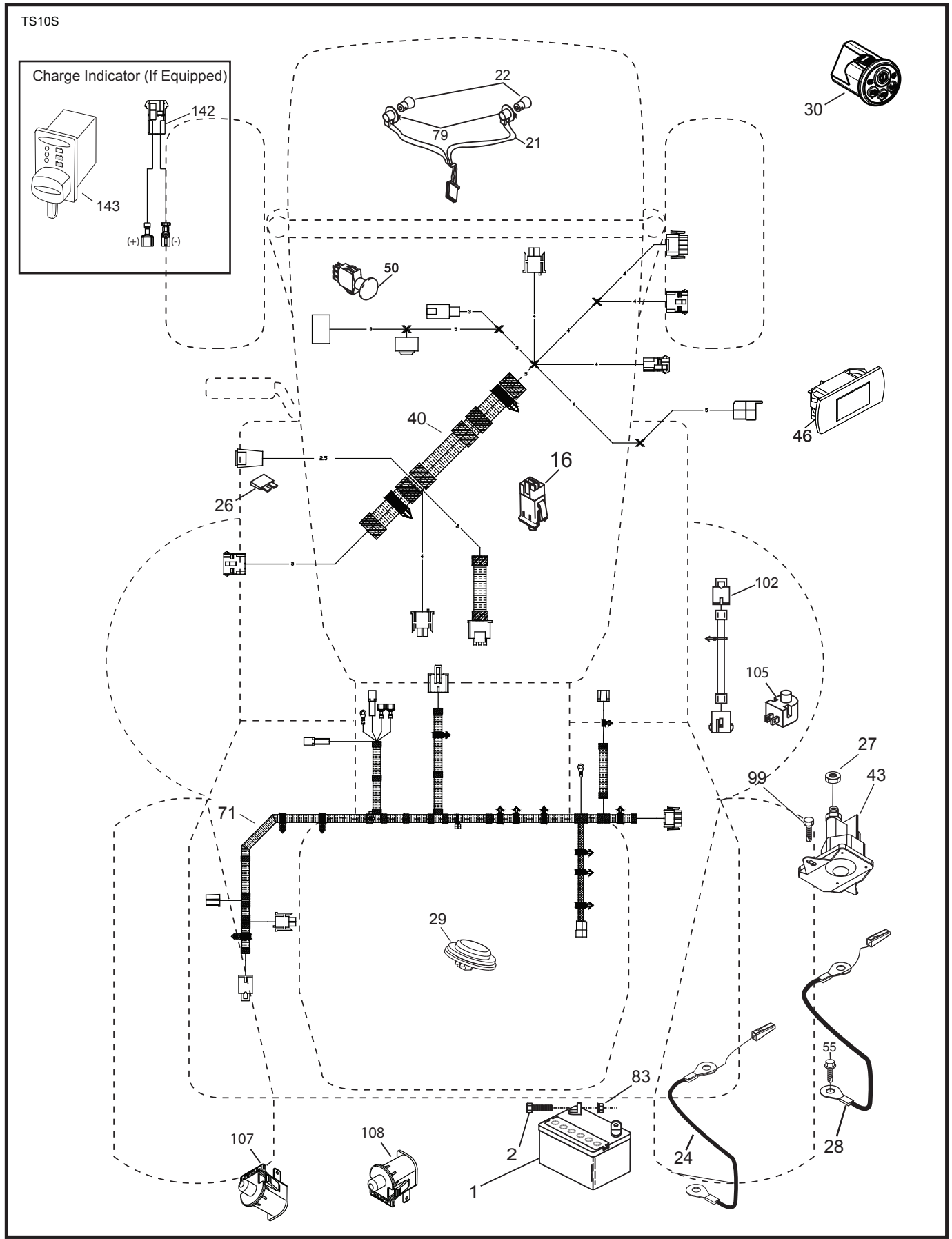

**TRACTOR - - MODEL NO. TC 238 (96051013701), PRODUCT NO. 960 51 01-37
ELECTRICAL 32**

KEY NO.	PART NO.	DESCRIPTION
1	532 43 71-57	Battery
2	532 44 09-23	Screw Hex Hd Cap M6 x 1.12MM
16	532 17 61-38	Switch Interlock Push-In
21	532 40 02-52	Harness Light
22	532 00 41-52	Bulb Light
24	585 73 43-02	Cable Battery Positive
26	532 17 51-58	Fuse
27	873 51 04-00	Nut Keps Hex 1/4-20 unc
28	585 30 69-03	Cable, Ground
29	581 42 93-02	Switch, Seat
30	586 83 67-03	Switch, Ign Smart
40	585 21 68-01	Harness Ign. Dash
43	582 04 28-01	Solenoid
46	586 16 18-01	Gauge Serviceminder Hrmtr
50	582 10 76-01	Switch PTO
55	817 06 05-12	Screw Thdrol 5/16-18 x 3/4 TYTT
71	585 21 66-01	Harness Ignition Chassis
79	532 17 52-42	Socket Asm. Bulb
83	532 43 67-74	Nut Square M6 x 1.8.5 x 11MM
99	817 00 05-12	Screw 5/16-18 x 3/4
102	532 44 12-62	Harness Jumper
105	532 40 75-68	Switch Reverse
107	532 18 03-79	Switch Full Bagger
108	532 16 07-84	Switch

NOTE: All component dimensions given in U.S. inches
1 inch = 25.4 mm

TRACTOR - - MODEL NO. TC 238 (96051013701), PRODUCT NO. 960 51 01-37
CHASSIS AND ENCLOSURES **39**

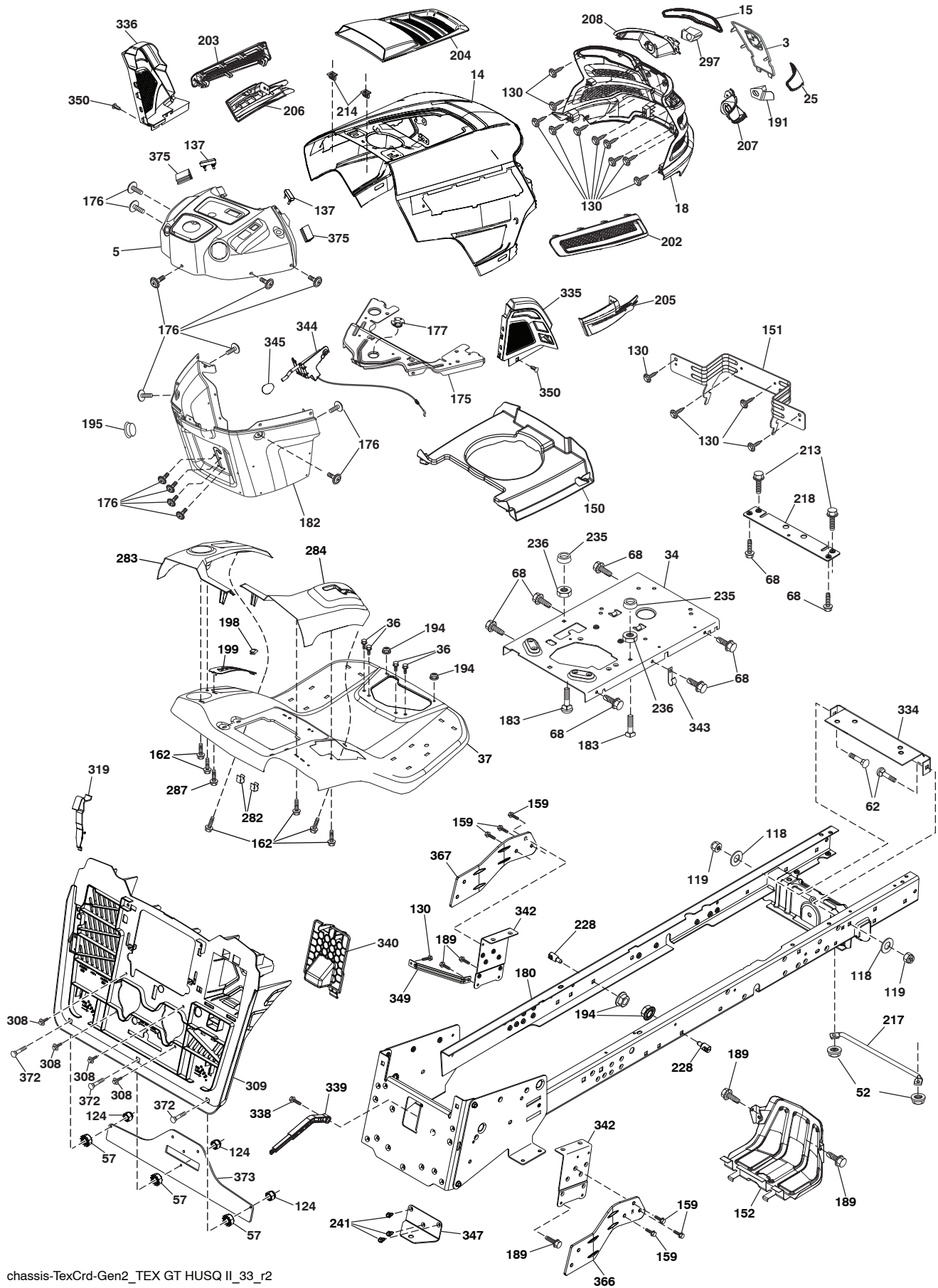

**TRACTOR - - MODEL NO. TC 238 (96051013701), PRODUCT NO. 960 51 01-37
CHASSIS AND ENCLOSURES 39**

KEY NO.	PART NO.	DESCRIPTION	KEY NO.	PART NO.	DESCRIPTION
3	532 44 44-81	Applique	213	874 76 05-12	Bolt 5/16-18 x 3/4
5	581 46 68-03	Dash	214	532 19 91-45	Clip Retainer Tinner
14	532 44 11-77	Hood	217	532 40 91-67	Rod Pivot
15	532 43 97-33	Lens LH	218	532 19 63-95	X-Piece Hood Stop
18	532 44 06-53	Grille	228	532 19 51-61	Stud Fastner
25	532 44 33-85	Lens RH	235	532 40 61-29	Spacer Fender
34	580 91 09-01	Plate Engine	236	873 93 05-00	Nut Lock 5/16-18 unc
36	817 06 05-12	Screw 5/16-18 x 3/4	241	817 06 05-16	Screw 5/16-18 x 1
37	532 44 14-19	Fender	282	532 41 41-10	Clip Retainer
52	873 68 05-00	Nut Lock 5/16-18	283	532 44 72-12	Console Deck Lift LH
57	873 51 04-00	Nut Keps w/insert 1/4-20 unc	284	532 44 72-20	Console Shft RH
62	872 11 06-08	Bolt RdHd Sqnk 3/8-16 x 1 Gr. 5	287	817 60 04-06	Screw 1/4-20 x 3/8
68	817 49 05-08	Screw Thdrol 5/16-18 x 1/2	297	532 43 74-56	Insert Reflective LH
118	819 13 13-16	Washer 13/32 x 13/16 x 16 Ga.	308	532 17 18-77	Bolt 5/16-18 unc x 3/4
119	873 68 06-00	Nut Crownlock 3/8-16 unc	309	581 32 89-11	Backplate
124	873 80 04-00	Nut Lock w/insert 1/4-20 unc	319	581 31 39-06	Lever Bag
130	532 41 63-58	Screw #10 x 0.750	334	532 44 25-37	Bracket Engine
137	532 40 75-90	Bumper Dash	335	532 44 82-04	Cover RH Lower Close Out
150	532 43 97-74	Air Duct	336	532 44 53-09	Cover LH Lower Close Out
151	532 43 66-70	Bracket Pivot	338	532 43 66-40	Bolt Shoulder
152	532 43 98-70	Shield Browning	339	532 43 66-41	Lever Bagger Full
159	817 00 06-12	Screw Hexwsh Thrd 3/8-16 x 3/4	340	581 32 90-01	Door Battery
162	532 14 24-32	Screw	342	582 82 68-02	Supprt Fender
175	532 19 63-04	Crossmember	343	532 44 07-49	Clip
176	532 40 07-76	Screw 10-24 x 5/8	344	532 43 89-70	Control EZ Mulch
177	532 19 52-28	Bushing Steering	345	532 44 06-39	Knob
180	583 90 27-01	Chassis	347	532 44 28-87	Hitch Tow
182	532 43 89-67	Dash Lower	349	532 43 66-06	Bracket Support
183	874 52 05-20	Bolt 5/16-18 x 1-1/4	350	532 44 51-43	Clip X-Mas Tree
189	817 00 05-12	Screw 5/16-18 x 3/4	366	581 31 46-02	Bracket RH Front Bagger
191	532 43 74-55	Insert Reflective RH	367	581 31 45-02	Bracket LH Front Bagger
194	873 90 05-00	Nut Lock Hex Flange 5/16-18	372	539 10 98-00	Carriage Bolt 1/4-20 x 1 Gr5
195	532 40 41-37	Plug Hole Dash Lower	373	586 29 98-03	Backplate Support
198	532 44 15-52	Indicator Deck Lift	375	586 90 82-01	Dash Clip-On Bumper
199	532 41 87-39	Plate Deck Lift	--	586 29 76-01	Plug Switch
202	532 43 97-28	Vent Side Hood RH	--	532 40 09-44	Bumper
203	532 43 97-27	Vent Side Hood LH			
204	532 43 57-14	Vent Top Hood			
205	532 43 97-30	Trim Hood Side RH			
206	532 43 97-29	Trim Hood Side LH			
207	532 43 97-34	Bezel RH			
208	532 43 97-35	Bezel LH			

NOTE: All component dimensions given in U.S. inches
1 inch = 25.4 mm

TRACTOR - - MODEL NO. TC 238 (96051013701), PRODUCT NO. 960 51 01-37
DRIVE **40**

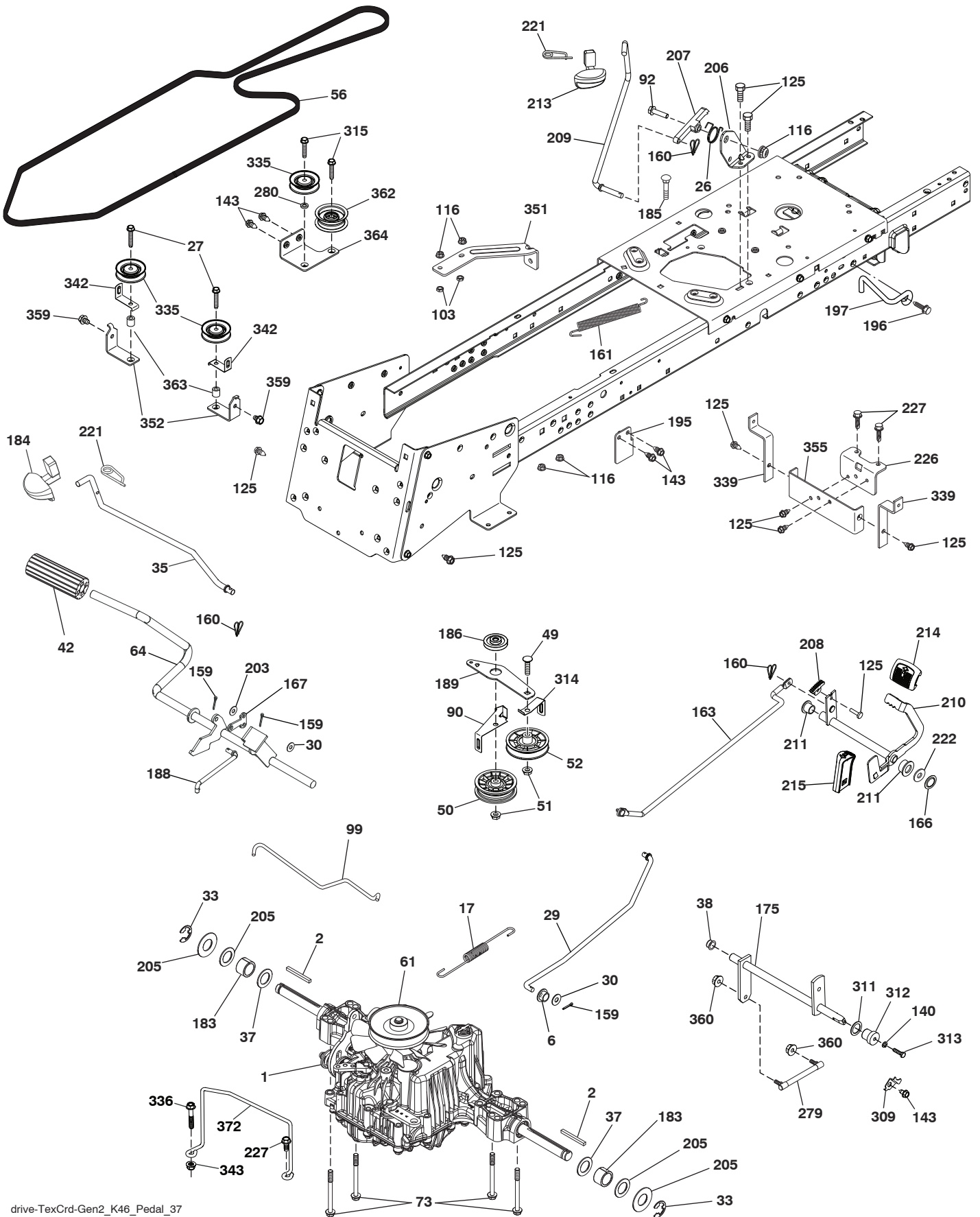

**TRACTOR - - MODEL NO. TC 238 (96051013701), PRODUCT NO. 960 51 01-37
DRIVE **40****

KEY NO.	PART NO.	DESCRIPTION	KEY NO.	PART NO.	DESCRIPTION
1	---	Transaxle, Tufftorq K46DF (446488) (Order parts from trans-axle manufacturer.)	196	817 00 06-16	Screw 3/8-16 x 1 Smgml Tap/R Blk
2	532 12 35-83	Key Square	197	585 65 86-01	Link Clutch Anti-Rotation
6	532 12 40-28	Bushing Snap	203	819 11 11-16	Washer 11/32 x 11/16 x 16 Ga.
17	532 43 62-27	Spring Brake K46	205	532 12 17-48	Washer 25/32 x 1-5/8 x 16 Ga.
26	532 19 96-79	Spring Return Cruise	206	532 44 85-96	Bracket Mount Latch Cruise
27	817 49 05-28	Screw Hexwsh Thd 5/16-18 x 1-3/4	207	587 03 14-01	Latch Control Cruise
29	532 44 27-95	Rod, Brake	208	532 19 78-69	Gear Sector Control Cruise
30	819 13 16-16	Washer	209	532 19 95-92	Rod Control Cruise
33	812 00 00-01	Ring E	210	532 40 09-80	Rocker Asm. Pedal Control
35	583 86 45-01	Rod, Brake, Park	211	532 12 01-83	Bearing Nylon
37	532 18 89-67	Washer Harden .793 x 1.063 x .060	213	532 40 31-19	Knob Control Cruise
38	532 16 96-13	Nyliner Bushing	214	532 42 12-63	Pedal Forward
42	532 12 48-72	Cover, Foot Pedal	215	586 60 65-02	Pedal Reverse
49	872 11 06-14	Bolt Rdhd 3/8-16 unc x 3/4 Gr. 5	221	532 40 31-87	Retainer Spring Clip Handle
50	532 19 43-27	Idler Flat	222	879 21 20-10	Washer 21/32 x 1-1/4 10 Ga.
51	873 90 06-00	Lock Nut 3/8-16	226	532 40 15-64	Bracket Strap Torque
52	532 19 43-26	Idler V-Groove	227	817 49 05-12	Screw
56	532 44 27-81	V-Belt, Drive	279	532 44 42-83	Link Shift
61	532 44 51-51	Pulley Transaxle K46	280	819 11 10-12	Washer 11/32 x 5/8 x 12 Ga.
64	532 19 78-65	Shaft Asm. Pedal Brake Control	309	532 16 55-81	Plate Fstnr Cross Shf
73	874 49 05-44	Bolt Flanged	311	532 16 98-45	Washer Nylon
90	532 44 36-05	Keeper Belt Clutching	312	532 16 56-14	Hub Tapered
92	874 76 05-20	Bolt Fin Hex 5/16-18 unc x 1.25	313	874 78 04-16	Bolt Hex Fin 1/4-20 unc x 1 Gd5
99	532 44 39-47	Rod Spring Bypass	314	532 44 47-13	Keeper Belt
103	873 35 05-00	Nut Hex Jam 5/16-18	315	817 58 05-20	Screw Thdrol 5/16-18 x 4.25
116	873 90 05-00	Nut Lock Hex Flange 5/16-18	335	532 19 95-34	Pulley V-Idler
125	817 00 05-12	Screw 5/16-18 x 3/4	336	587 25 96-01	Bolt 5/16-18 x 1-3/4 Flanged hex
140	810 04 04-00	Washer Lock Hvy Helical 1/4	339	532 43 68-67	Strap Torque K46 CRD Tex
143	817 49 05-08	Screw 5/16-18 x 1/2	342	532 18 26-82	Keeper Belt 2.5" STL V-Idlr CRD
159	876 02 04-12	Pin Cotter 1/8 x 3/4	343	539 11 28-99	Nut 5/16-18 Hex Flanged Nyloc
160	532 16 94-84	Retainer Clip	351	532 43 69-98	Bracket 97 CRD Deck Sway
161	532 10 57-09	Spring, Return, Clutch	352	532 43 56-45	Bracket Idler CRD Tex
163	532 44 27-93	Rod Control	355	532 43 56-69	Strap Torque
166	532 42 91-64	Nut Push	359	817 49 06-10	Screw Thdrol 3/8-16 x 5/8
167	532 40 52-57	Latch Brake Parking	360	532 44 47-14	Nut 5/16-24 UNF
175	532 42 93-59	Shaft Asm Crossshift Rear Crd	362	532 43 68-12	Idler Flat
183	532 13 70-57	Spacer Axle	363	532 44 27-80	Spacer 343 x 63 x .62
184	587 65 37-01	Handle Parking Brake	364	532 44 30-32	Bracket Idler CRD Tex
185	872 11 06-22	Bolt 3/8-16 unc x 2-3/4 G5	372	582 65 49-01	Keeper Belt Transaxle
186	532 19 43-21	Spacer Retainer			
188	582 21 70-01	Link Clutch, Long			
189	532 43 36-11	Bellcrank Ground Drive			
195	580 45 69-01	Bracket Rod Brake CRD Tex			

NOTE: All component dimensions given in U.S. inches
1 inch = 25.4 mm

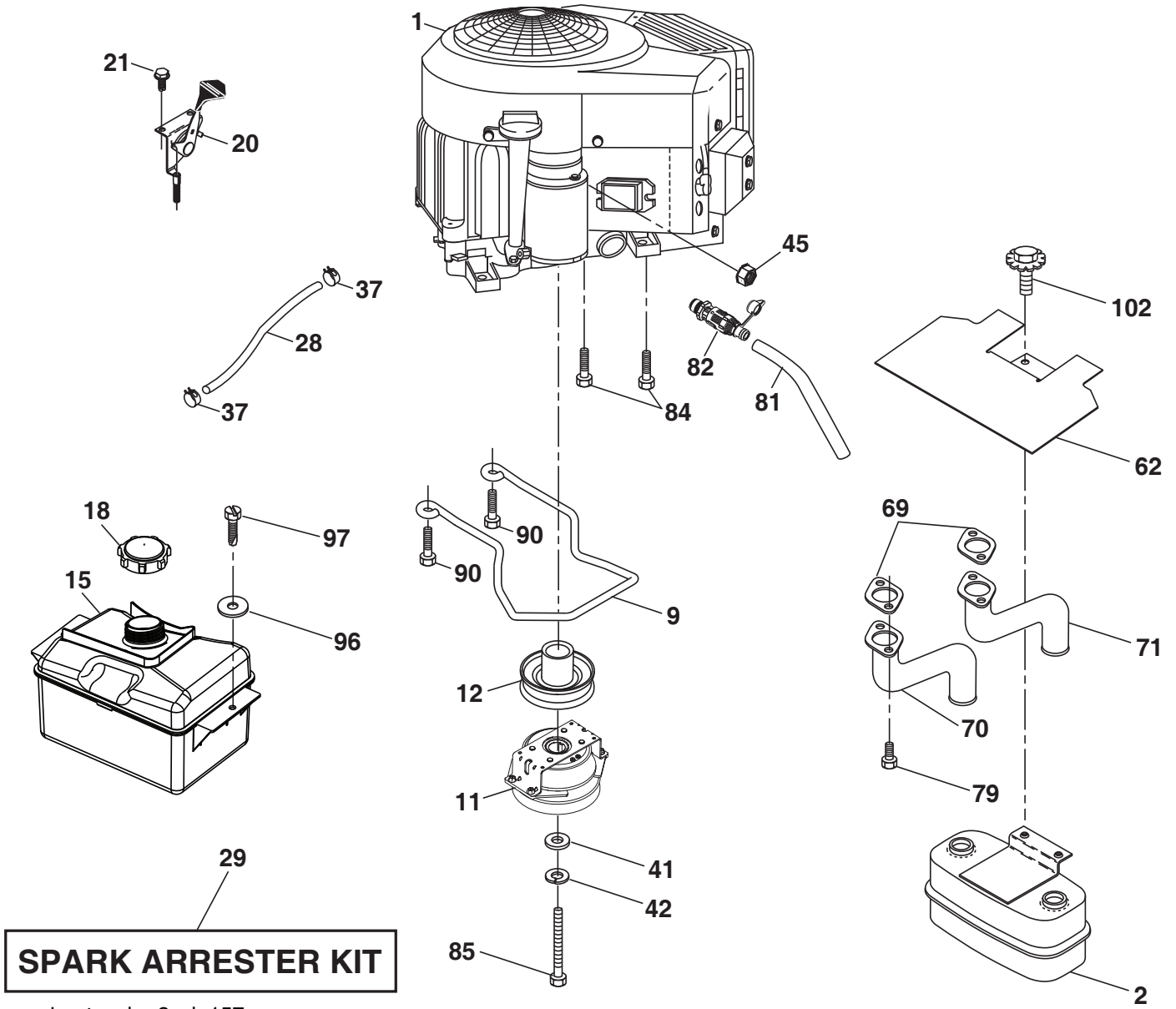

engine-tex_bs-2cyl_157

**TRACTOR - - MODEL NO. TC 238 (96051013701), PRODUCT NO. 960 51 01-37
ENGINE 24**

KEY NO.	PART NO.	DESCRIPTION
1	- - - - -	Engine B&S Model No. 40N877-0016-G1 (501258601) (Order parts from engine manufacturer.)
2	532 44 59-62	Muffler
9	501 83 26-02	Keeper Belt Engine
11	587 24 16-01	Clutch Electric
12	532 40 50-97	Pulley Engine
15	581 29 01-01	Tank Fuel
18	532 43 02-20	Fuel Cap
20	587 24 25-01	Control Throttle
21	532 41 63-58	Screw # 10 x 0.750
28	532 13 70-40	Fuel Line
29	532 13 71-80	Spark Arrester Kit
37	532 12 34-87	Clamp Hose
41	532 12 61-97	Washer 1-1/2 OD x 15/32 ID x .250
42	539 99 02-47	Washer 7/16
45	873 51 04-00	Nut Keps Hex 1/4-20 unc
62	532 43 40-17	Shield Heat Muffler
69	532 16 53-91	Gasket
70	581 88 11-01	Tube Exhaust LH
71	581 88 10-01	Tube Exhaust RH
79	532 18 39-06	Screw Socket
81	532 14 84-56	Tube Drain Oil Easy
82	532 42 82-87	Valve Oil Drain
84	817 06 06-20	Screw
85	501 60 66-01	Bolt Hex 7/16-20 x 3.75 G5
90	817 00 06-16	Screw 3/8-16 x 1
96	819 09 14-16	Washer 9/32 x 7/8 x 16 Ga.
97	817 67 04-12	Screw 1/4-20 x 3/4
102	817 00 05-12	Screw 5/16-18 x 3/4

NOTE: All component dimensions given in U.S. inches
1 inch = 25.4 mm

Engine Power Rating Information

The gross power rating for individual gas engine models is labeled in accordance with SAE (Society of Automotive Engineers) code J1940 (Small Engine Power & Torque Rating Procedure), and rating performance has been obtained and corrected in accordance with SAE J1995 (Revision 2002-05). Torque values are derived at 3060 RPM; horsepower values are derived at 3600 RPM. Actual gross engine power will be lower and is affected by, among other things, ambient operating conditions and engine-to-engine variability. Given both the wide array of products on which engines are placed and the variety of environmental issues applicable to operating the equipment, the gas engine will not develop the rated gross power when used in a given piece of power equipment (actual "on-site" or net power). This difference is due to a variety of factors including, but not limited to, accessories (air cleaner, exhaust, charging, cooling, carburetor, fuel pump, etc.), application limitations, ambient operating conditions (temperature, humidity, altitude), and engine-to-engine variability. Due to manufacturing and capacity limitations, Briggs & Stratton may substitute an engine of higher rated power for this Series engine.

TRACTOR - - MODEL NO. TC 238 (96051013701), PRODUCT NO. 960 51 01-37
STEERING ASSEMBLY **41**

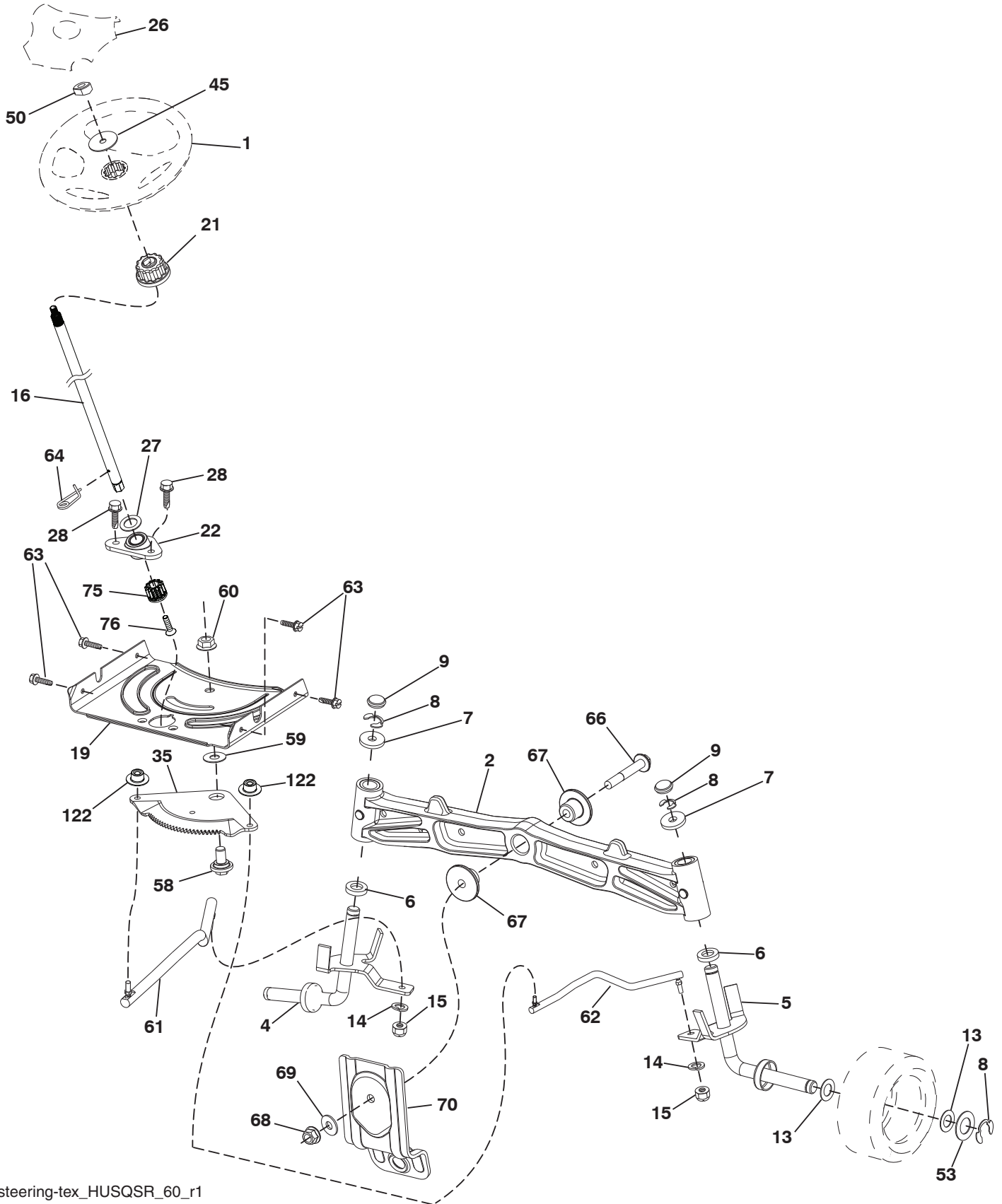

steering-tex_HUSQSR_60_r1

**TRACTOR - - MODEL NO. TC 238 (96051013701), PRODUCT NO. 960 51 01-37
STEERING ASSEMBLY 41**

KEY NO.	PART NO.	DESCRIPTION
1	532 43 97-40	Wheel, Steering
2	532 19 59-68	Axle Asm., Front
4	532 40 30-87	Spindle Asm., LH
5	532 40 30-88	Spindle Asm., RH
6	532 12 49-31	Washer Thrust 0.75 x 1.23
7	532 12 17-48	Washer 25/32 x 1-5/8 x 16 Ga.
8	812 00 00-29	Ring, Klip #T5304-75
9	532 12 12-32	Cap, Spindle
13	532 12 17-49	Washer 25/32 x 1-1/4 x 16 Ga.
14	539 99 01-18	Washer 3/8
15	873 54 06-00	Nut, Crown Lock 3/8-24 unf
16	587 01 60-02	Shaft Steering
19	532 19 47-29	Plate Steering
21	586 84 02-01	Adapter, Wheel Steering Splnd Alum
22	585 02 98-02	Bearing Subasm Shaft Steer Low
26	532 43 97-43	Insert, Wheel Steering
27	819 21 16-16	Washer 21/32 x 1 x 16 Ga.
28	817 00 06-12	Screw 3/8-16 x 3/4
35	532 19 47-32	Gear, Sector Plate
45	587 01 64-01	Washer 3/8 ID 2-3/8OD 12 Ga. PLTD
50	873 90 06-00	Nut Lock Flg. 3/8-16 unc
53	532 18 89-67	Washer Hardened .793 x 1.637 x .060
58	532 19 47-47	Bolt Shoulder Sector Pivot CFM
59	532 19 47-48	Washer Thrust Sector Steering
60	873 97 10-00	Nut Flange Lock 5/8-11
61	588 79 44-01	Draglink, LH
62	588 79 45-01	Draglink, RH
63	817 00 05-12	Screw 5/16-18 x 3/4
64	532 19 98-49	Retainer Clip Spring Steering
66	871 02 07-48	Bolt Hex Fghd 7/16-14 x 3 Serr
67	532 19 47-37	Bushing PM Front Axle
68	873 90 07-00	Nut Lock Flange 7/16-14 Gr. 5
69	532 19 91-62	Washer 1.5 x .505 x .118
70	585 33 88-01	Bracket Deck Susp. Front
75	580 68 37-01	Pinion
76	580 68 36-01	Screw Head Sock
122	532 44 49-62	Cap Gear

NOTE: All component dimensions given in U.S. inches
1 inch = 25.4 mm

TRACTOR - - MODEL NO. TC 238 (96051013701), PRODUCT NO. 960 51 01-37
MOWER DECK 44

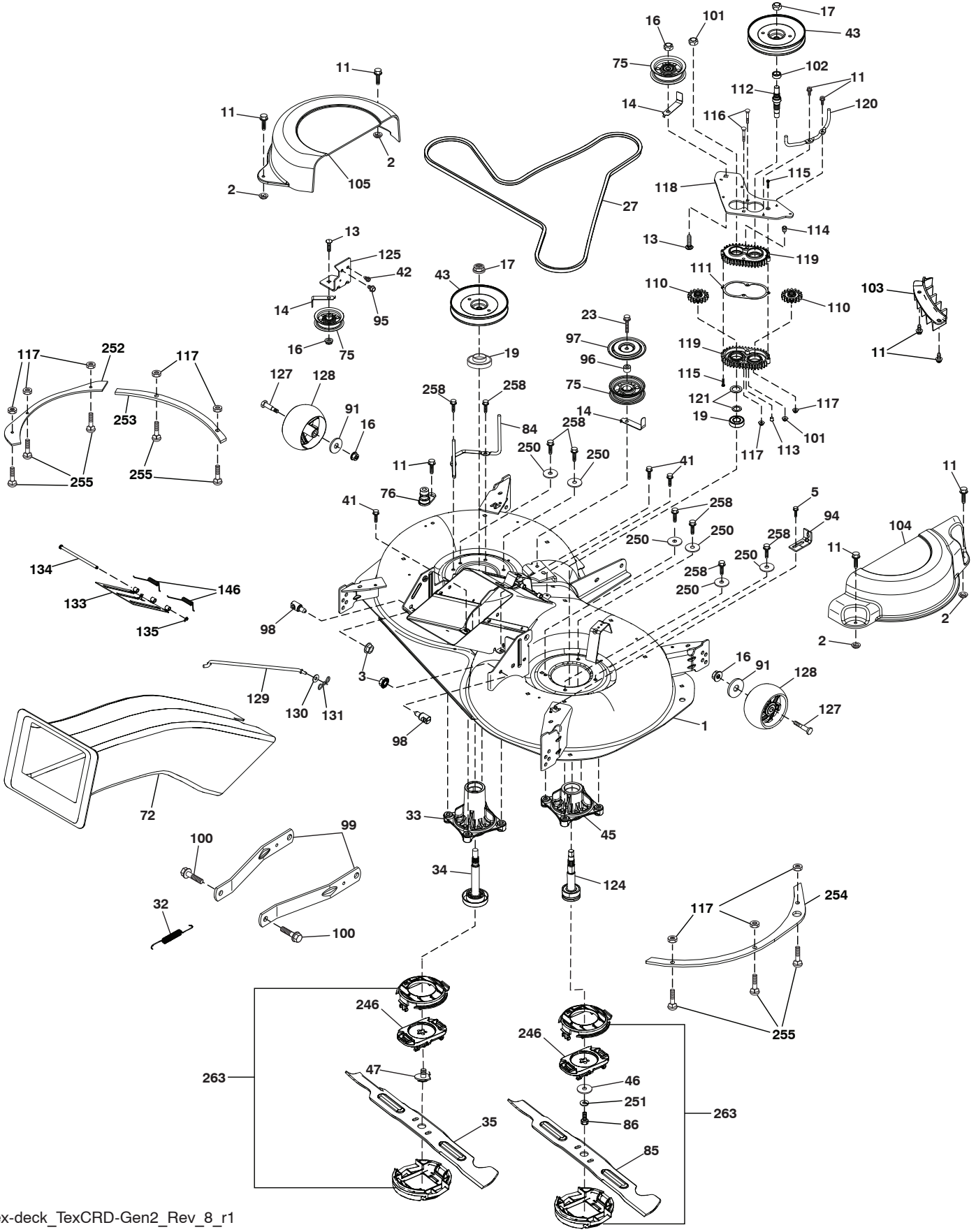

tex-deck_TexCRD-Gen2_Rev_8_r1

**TRACTOR - - MODEL NO. TC 238 (96051013701), PRODUCT NO. 960 51 01-37
MOWER DECK 44**

KEY NO.	PART NO.	DESCRIPTION	KEY NO.	PART NO.	DESCRIPTION
1	580 46 53 02	Deck Weldment	118	532 43 69-89	Arm Clutching
2	532 42 30-62	Palnut 1/4	119	532 43 81-66	Gearcase Subasm
3	873 90 05-00	Nut Lock Hex Flange 5/16 - 18	120	532 43 69-91	Keeper Belt RH
5	817 00 05-10	Bolt 5/16-18	121	532 43 69-85	Washer
11	532 13 77-29	Screw Thd Roll 1/4 - 20 X 5/8	124	581 65 07-01	Non Greasable Mandrel Shaft
13	872 11 06-12	Bolt Carr Sh 3/8 - 16 X 1 - 1/2 Gr. 5	125	532 43 69-94	Bracket Idler Chassis
14	532 15 60-85	Keeper Belt Idler	127	532 19 34-06	Bolt Shoulder 3/8-16 x 3-5/8 Gr. 5
16	873 90 06-00	Nut Lock FIG 3/8 - 16 unc	128	532 17 48-73	Wheel Gauge
17	532 40 02-34	Nut Flange Lock Top	129	532 44 32-37	Rod Anti-Sway
19	532 11 04-85	Bearing Mandrel	130	819 13 13-12	Washer 13/32 x 13/16 x 12 Ga.
23	817 49 06-28	Screw Thdrol 3/8 - 16 X 1-3/4	131	532 19 42-08	Pin Cotter 5/16 Bow Tie Lock
27	532 44 58-34	V-Belt Drive	133	532 43 55-38	Mulch Door
32	532 44 62-05	Spring Return Deck	134	532 43 58-61	Pin Hinge
33	580 79 61-01	Mandrel Asm. Tall	135	532 43 79-88	E-Ring 5/16
34	580 85 47-01	Shaft Asm Mndrl	146	532 44 58-96	Spring Tex CRD EZ Mulch
35	580 98 33-01	Blade Mower LH	246	580 95 40-03	Blade Holder Revolution
41	584 95 39-01	Bolt Hex WSHRHD 313 - 18 x 1.19	250	819 11 12-12	Washer 11/32 x 3/4 x 12 Ga.
42	817 00 05-12	Screw 5/16-18 x 3/4	251	539 99 02-47	Washer Lock 7/16
43	532 19 97-89	Pulley Mandrel	252	585 30 87-05	Plate Reinforcement LH FT
45	581 65 08-01	Mandrel Asm. Short	253	585 30 88-05	Plate Reinforcement LH
46	585 72 99-01	Flat Washer 3/8	254	585 30 90-05	Plate Reinforcement RH
47	584 30 93-01	Screw SEMS 7/16-20 x 1	255	539 10 98-00	Carriage Bolt
72	581 45 41-03	Chute Upper	258	584 95 39-01	Bolt Hex Wsh Hd .316-18 x 1.19
75	532 13 14-94	Pulley Idler Flat	263	586 63 85-01	Upper/Lower Cap Asm.
76	532 41 55-98	Washout Port	--	587 12 61-05	Mandrel Assembly Tall (Includes Housing (key #33), Shaft Assembly (key #34), And Bearing Only (key #19) - Pulley/Nut/Washer And Blade Bolt/Washers Not Included)
84	532 40 01-40	Keeper Belt Mandrel	--	581 65 05-01	Mandrel Assembly Short (Includes Housing (key #45), Shaft Assembly (key #124), And Bearing Only (key #19) - Pulley/Nut/Washer And Blade Bolt/Washers Not Included)
85	580 98 34-01	Blade Mower RH	--	588 78 29-01	Replacement Mower Complete
86	532 18 17-13	Bolt 3/8-24 x 1.50 Gr.8	--	532 44 81-32	Gear Case Kit – Use .75 oz. Shell 460 oil (Include Gear Output (key #110), Gasket Gearcase (key #111), Shaft Gearcase (key #112), Plug Oil (key #113), Vent Breather 1/8 NPT (key #114), Screw Torx (key #115), Gearcase Subasm (key #119))
91	819 13 20-12	Washer 13/32 x 1-1/4 x 12 Ga.			
94	532 19 72-50	Bracket Clutch Cable			
95	817 00 06-12	Screw 3/8-16 x 3/4			
96	532 40 02-71	Spacer			
97	532 18 20-61	Shield Idler Mower			
98	532 19 51-61	Stud Fastener			
99	532 19 51-86	Arm Suspension Mower Rear			
100	532 19 65-39	Bolt Shoulder			
101	873 68 09-00	Nut Crownlock 9/16 - 18 unc			
102	532 40 25-11	Spacer Bearing Swing Plate			
103	532 43 69-92	Guard Front Vent			
104	532 43 89-68	Mandrel Cover RH			
105	532 43 87-44	Mandrel Cover LH			
110	587 93 48-01	Gear Output			
111	532 43 69-79	Gasket Gearcase			
112	532 44 38-52	Shaft Gearcase			
113	532 43 85-33	Plug Oil			
114	588 17 05-01	Valve Breather			
115	818 03 10-16	Screw Torx #10-24 x 1			
116	872 11 04-14	Bolt 1/4-20 x 1.75 Gr. 5			
117	873 90 04-00	Nut Hex Flange 1/4-20 unc			

NOTE: All component dimensions given in U.S. inches
1 inch = 25.4 mm

TRACTOR - - MODEL NO. TC 238 (96051013701), PRODUCT NO. 960 51 01-37
MOWER LIFT 45

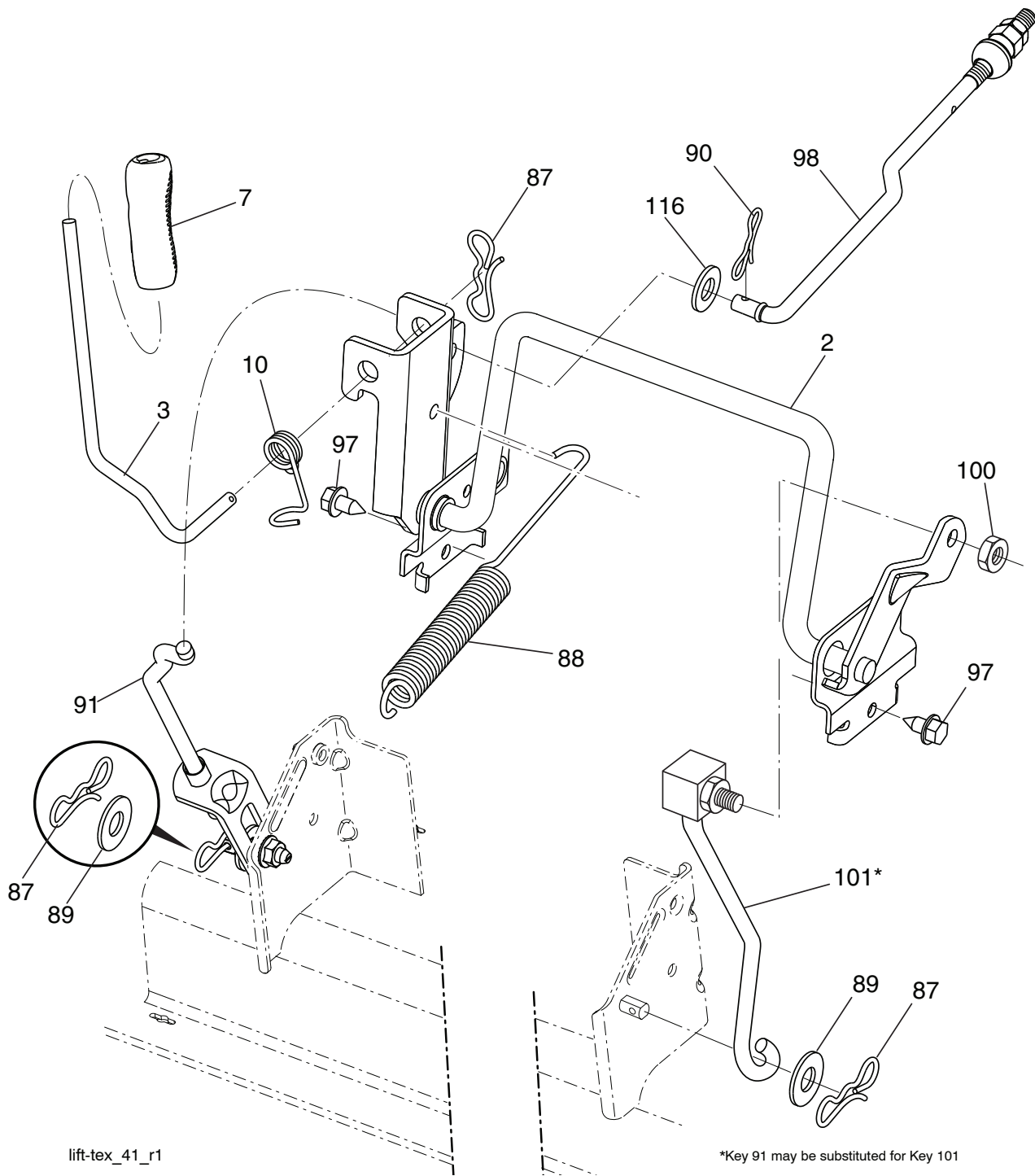

KEY NO.	PART NO.	DESCRIPTION
2	532 43 69-96	Deck Lift Weldment
3	532 19 52-31	Lever Asm., Lift RH
7	580 96 23-01	Grip, Lever
10	532 19 63-14	Spring Torsion
87	532 19 42-09	Pin Cotter 7/16 Bow Tie Lock
88	532 44 54-96	Spring Lift Assist
89	819 19 19-12	Washer Clear Zinc
90	532 19 42-08	Pin Cotter 5/16 Bow Tie Lock
91	532 19 51-81	Link Lift Susp Mower Rear

KEY NO.	PART NO.	DESCRIPTION
97	817 49 06-08	Screw 3/8-16 x 1/2
98	532 19 52-70	Link Lift Susp. Front Mower
100	873 93 06-00	Nut Centerlock 3/8-16 unc
101	532 40 70-03	Link Asm. Lift Fixed
116	819 15 15-16	Washer 15/32 x 15/16 x 16 Ga.

NOTE: All component dimensions given in U.S. inches
 1 inch = 25.4 mm

**TRACTOR - - MODEL NO. TC 238 (96051013701), PRODUCT NO. 960 51 01-37
SEAT ASSEMBLY 42**

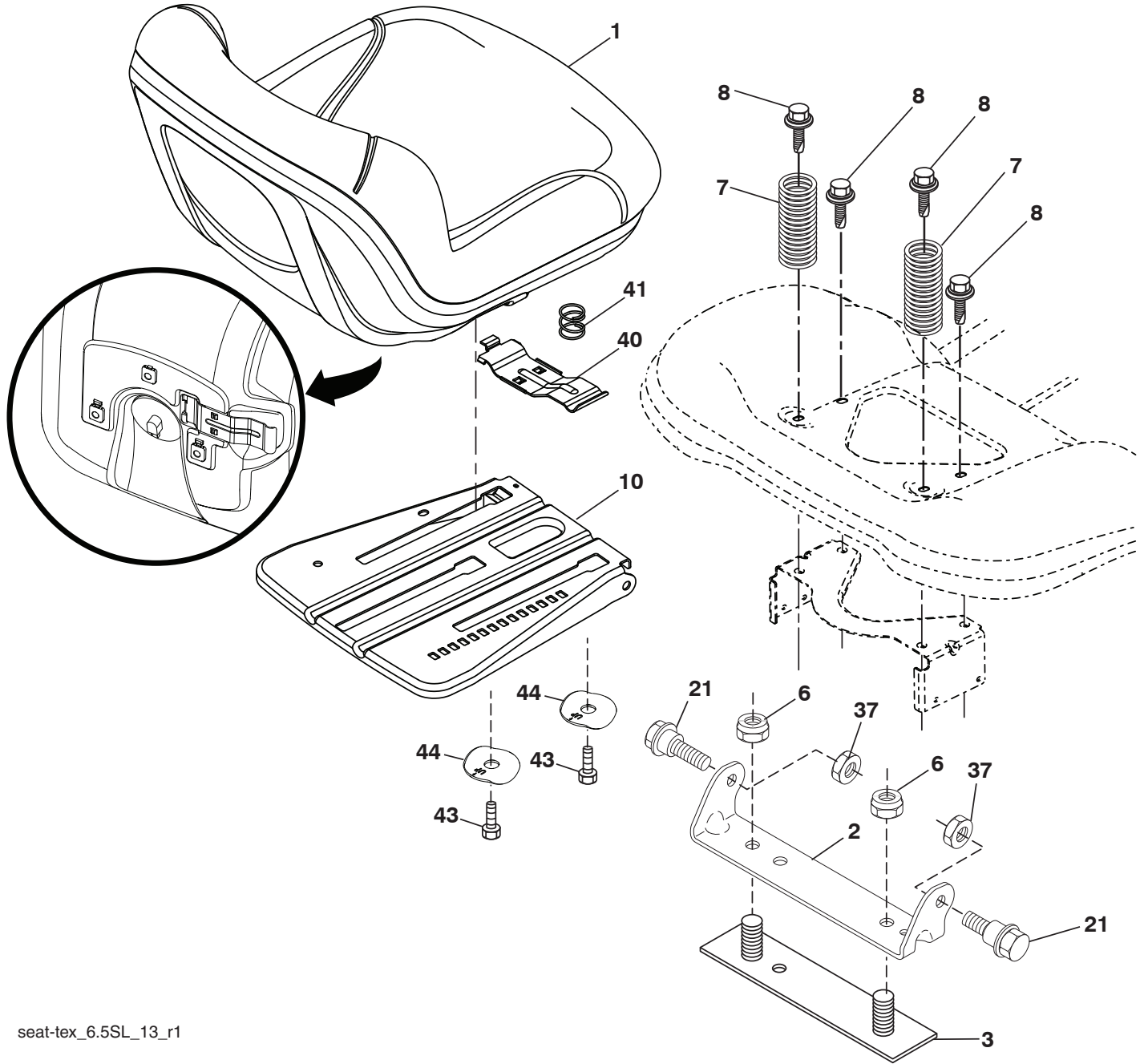

seat-tex_6.5SL_13_r1

KEY NO.	PART NO.	DESCRIPTION
1	532 43 98-22	Seat
2	532 18 01-66	Bracket Pivot Fender
3	532 14 06-75	Strap Fender
6	873 80 06-00	Nut, Lock W/Ins. 3/8-16 unc
7	589 48 35-01	Spring, Seat Cprsn
8	532 17 18-77	Bolt 5/16-18 unc x 3/4 w/Sems
10	587 23 20-02	Pan, Seat
21	587 90 78-01	Bolt, Shoulder 5/16-18 x 5/8
37	873 80 05-00	Nut, Lock 5/16-18 unc

KEY NO.	PART NO.	DESCRIPTION
40	532 43 98-71	Handle Slide Seat
41	532 19 82-00	Spring Latch Seat
43	874 76 06-12	Bolt Fin Hex 3/8-16 unc x 3/4
44	501 05 18-01	Washer Winged 3/8 ID 1.25 OD

NOTE: All component dimensions given in U.S. inches
1 inch = 25.4 mm

TRACTOR - - MODEL NO. TC 238 (96051013701), PRODUCT NO. 960 51 01-37
BAGGER **46**

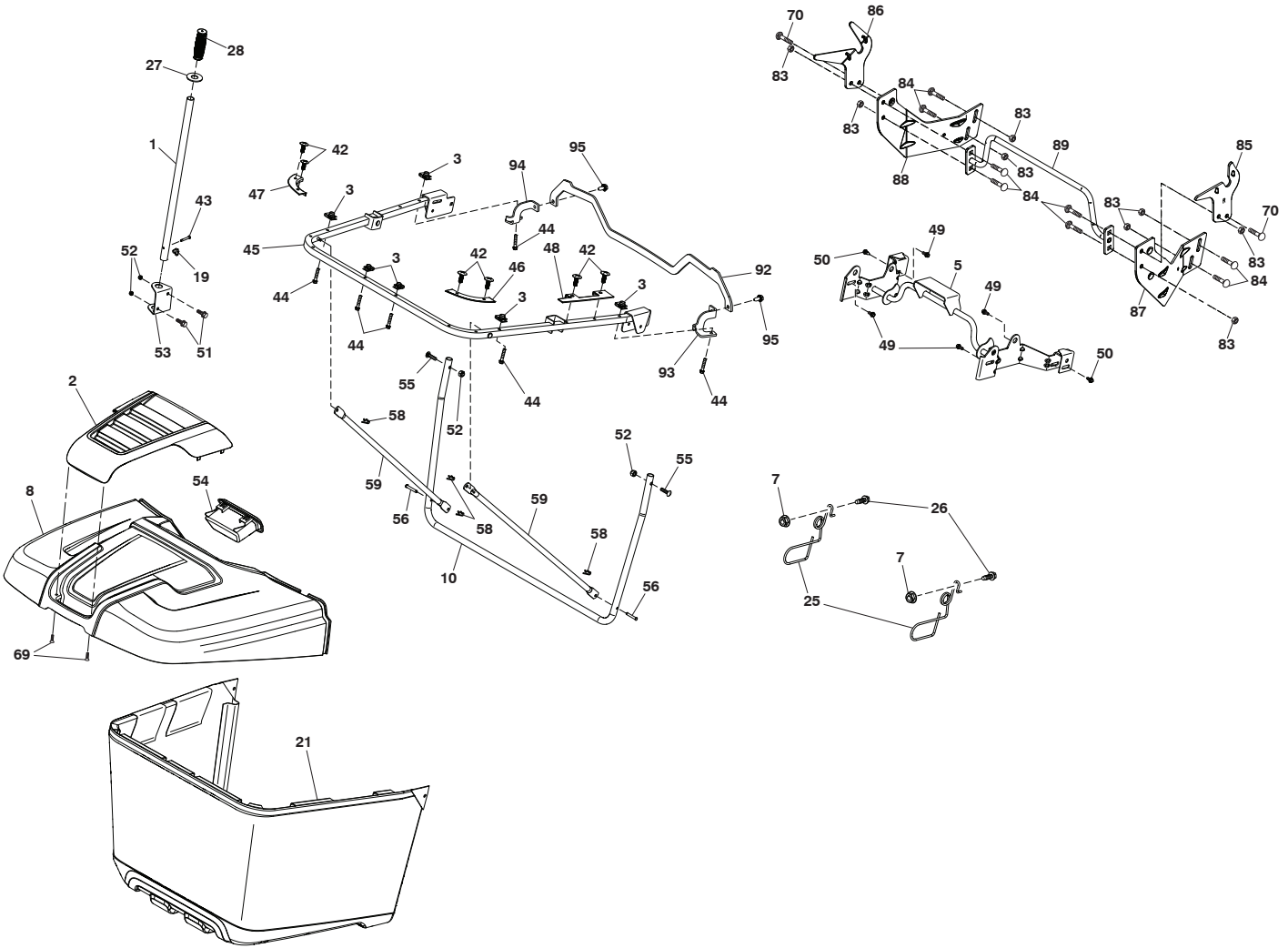

Bagger_TexCRD-Gen2_6_r1

**TRACTOR - - MODEL NO. TC 238 (96051013701), PRODUCT NO. 960 51 01-37
BAGGER 46**

KEY NO.	PART NO.	DESCRIPTION
1	532 42 86-10	Tube Handle Bagger
2	532 44 75-72	Applique
3	532 17 48-14	Clip
5	532 44 37-62	Upper Pivot Tube
7	873 90 04-00	Nut Hex Flange 1/4-20 unc
8	532 44 75-75	Bagger Top
10	532 44 37-55	Frame Front
19	532 19 42-08	Cotter Pin 5/16 Bow Tie
21	581 33 71-03	Bag Asm
25	532 44 55-28	Spring Latch Bagger
26	817 49 04-12	Screw Hex Thdrol 1/4-20 x 3/4
27	532 44 55-29	Grommet Rubber
28	532 16 57-87	Grip Handle
42	532 44 04-28	Clip
43	532 12 68-75	Clevis Pin
44	532 19 96-87	Bolt 1/4-20
45	532 44 37-54	Upper Frame
46	532 44 55-41	Bag Corner Close Out RH
47	532 44 40-79	Bag Corner Close Out LH
48	532 44 40-80	Top Bagger Side Close Out
49	532 17 18-73	Bolt Shoulder 5/16-18
50	532 17 18-77	Bolt 5/16-18 x 3/4 W/Sems
51	872 11 05-06	Bolt 5/16 x 18 x 3/4
52	873 80 05-00	Nut Lock Hex W/Ins 5/16-18 unc
53	532 44 41-95	Bracket Dump Handle
54	532 44 72-18	Bagger Top Front Handle
55	872 14 05-12	Bolt 5/16-18 x 1-1/2
56	532 42 03-06	Pin Clevis .183 x 1.26
58	532 12 47-88	Clip Retainer
59	532 44 47-63	Bagger Sprd Tube
69	532 42 18-01	Screw #8 Flat Head Drill
70	817 00 06-12	Screw 3/8-16 x 3/4
83	873 80 06-00	Nut Lock Hex w/Ins. 3/8-16 unc
84	872 11 06-08	Bolt 3/8-16 x 1 Gr. 5
85	581 31 44-02	Bracket RH Pivot
86	581 31 43-02	Bracket LH Pivot
87	581 31 48-02	Bracket RH
88	581 31 47-02	Bracket LH
89	581 31 51-04	Weldment Offset Strut
92	586 05 23-02	Bracket Top Support
93	586 05 24-02	Bracket Support RH
94	586 05 25-02	Bracket Support LH
95	817 00 05-12	Screw 5/16-18 x 3/4

NOTE: All component dimensions given in U.S. inches
1 inch = 25.4 mm

