



Parts Manual

Zero Turn Mower / P-ZT 54

966613403-02

Please read the operator manual carefully and make sure you understand the instructions before using the machine.



When you need spare parts or support in service questions, warranty issues, etc., please consult the following professional:

This manual belongs to the machine with the manufacturing number:	Engine	Transmission

Manufacturing Number

The machine's manufacturing number can be found on the printed plate affixed to the engine compartment.

Stated on the plate, from the top are:

- The machine's type designation (I.D.).
- The manufacturer's type number (Model).
- The machine's serial number (Serial no.)

Please have the type designation and serial number available when ordering spare parts.

CONTENTS

FRAME.....	4
ENGINE MOUNTING, GUARDS & MUFFLER	6
STEERING	8
IGNITION SYSTEM.....	10
PARKING BRAKE	12
HYDRAULIC PUMP-MOTOR.....	14
HYDRAULIC FRAME	16
WHEELS & TIRES	18
MOWER LIFT / DECK LIFT.....	20
MOWER DECK / CUTTING DECK	22
BLADESHAFT	24
SEAT	26
DECALS	28
PROTECTION FRAME	30

Illustrations may or may not represent the actual assemblies and it is not recommended to use this manual as a guide to assemble or disassemble the mower.

NOTE: All fasteners are Grade 5 unless otherwise specified.

FRAME

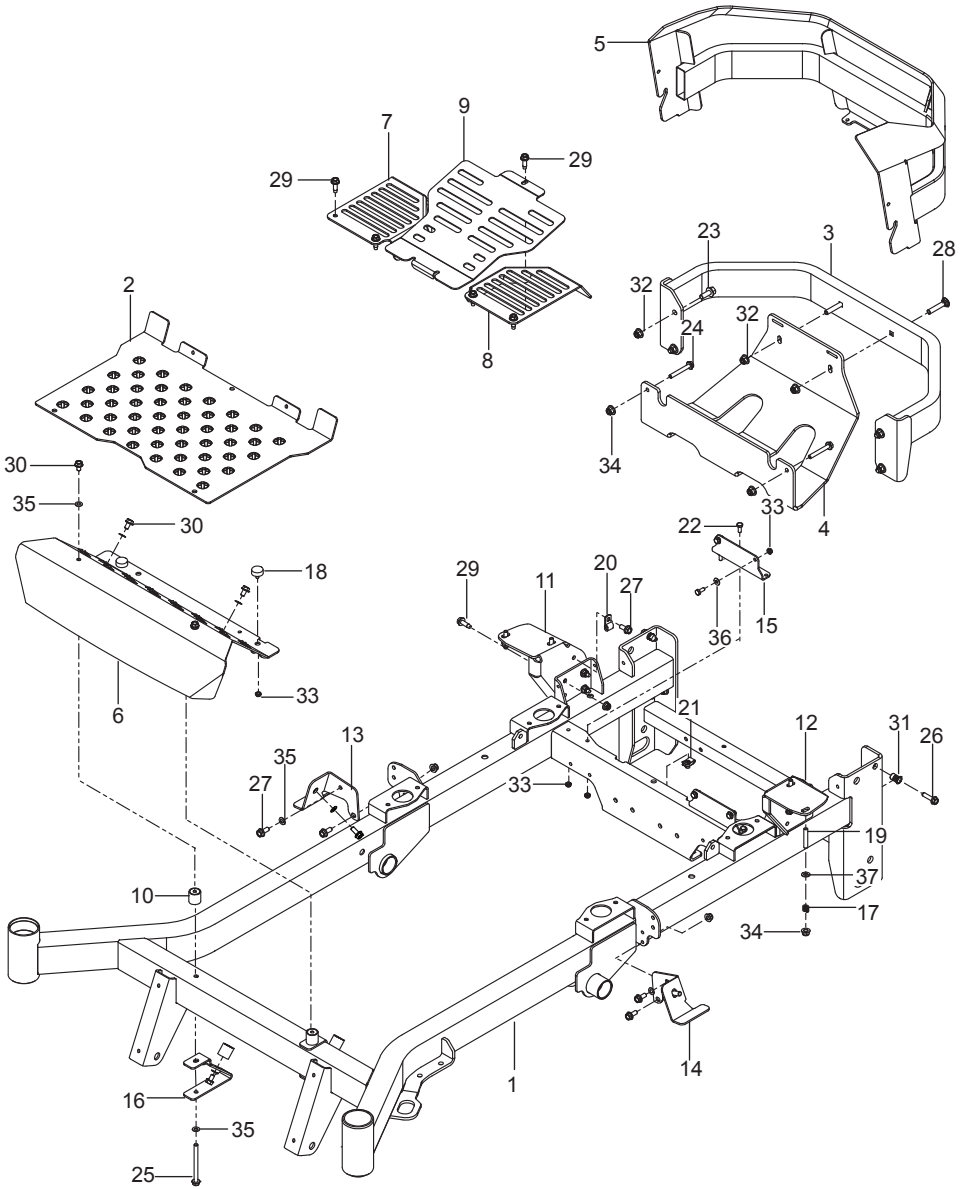

Ref.	Part No.	Qty	Description
1	574 48 28-01	1	Frame w/ Safety Decal Orange
2	576 70 13-02	1	Floor Pan Orange
3	522 73 89-02	1	Bumper, Rear Orange
4	576 70 14-02	1	Plate, Skid Gry
5	584 85 93-02	1	Guard, Rear Gry
6	574 21 57-02	1	Footrest Orange
7	576 70 15-02	1	Cover, Fan Right Black
8	576 70 16-02	1	Cover, Fan Left Black
9	576 70 17-02	1	Cover, Center Black
10	510 08 32-01	4	Mount, F/F Insert
11	529 27 96-03	1	Mount, Tank Right Rear
12	529 27 97-03	1	Mount, Tank Left Rear
13	529 27 99-03	1	Mount, Tank Right Front
14	529 28 00-03	1	Mount, Tank Left Front
15	576 45 36-02	2	Mount, Tank Black
16	510 04 03-01	2	Bracket, Rest Mount
17	539 10 28-45	4	Spring, Tank Mount
18	575 81 15-01	2	Bumper, 1/4-20 Stud 3/8"
19	539 10 25-02	4	Stud, Fuel Tank
20	539 10 98-67	1	Clamp, Double Tube
21	539 10 47-63	1	Retainer, U Type
22	874 78 04-12	8	Bolt 1/4-20 x 5/8 Hex Head
23	525 61 28-01	4	Bolt 3/8-16 x 1 Hex Flange Head
24	574 23 38-01	2	Bolt 5/16-18 x 2-1/4 Hex Flange Head
25	539 13 17-80	2	Bolt 5/16-18 x 3-3/4 Hex Flange Head
26	525 54 40-01	2	Bolt 5/16-18 x 1-1/4 Hex Flange Head
27	874 49 05-12	7	Bolt 5/16-18 x 3/4 Hex Flange Head
28	539 10 01-45	2	Bolt 3/8-16 x 2 Round Head Square Neck
29	817 49 05-16	11	Screw 5/16-18 x 1 Thread Form
30	817 49 05-08	6	Screw 5/16-18 x 1/2 Self Tap
31	539 11 10-28	2	Nutsert 5/16-18
32	521 99 65-01	2	Nut 3/8-16 Hex Flange Nyloc
33	539 10 81-20	10	Nut 1/4-20 Hex Thin Nyloc
34	539 11 28-99	14	Nut 5/16-18 Hex Flange Nyloc
35	539 10 96-00	8	Washer 5/16 Disc Spring
36	539 99 00-55	4	Washer 1/4 SAE Flat
37	819 11 11-16	4	Washer 5/16 SAE Flat

ENGINE MOUNTING, GUARDS & MUFFLER

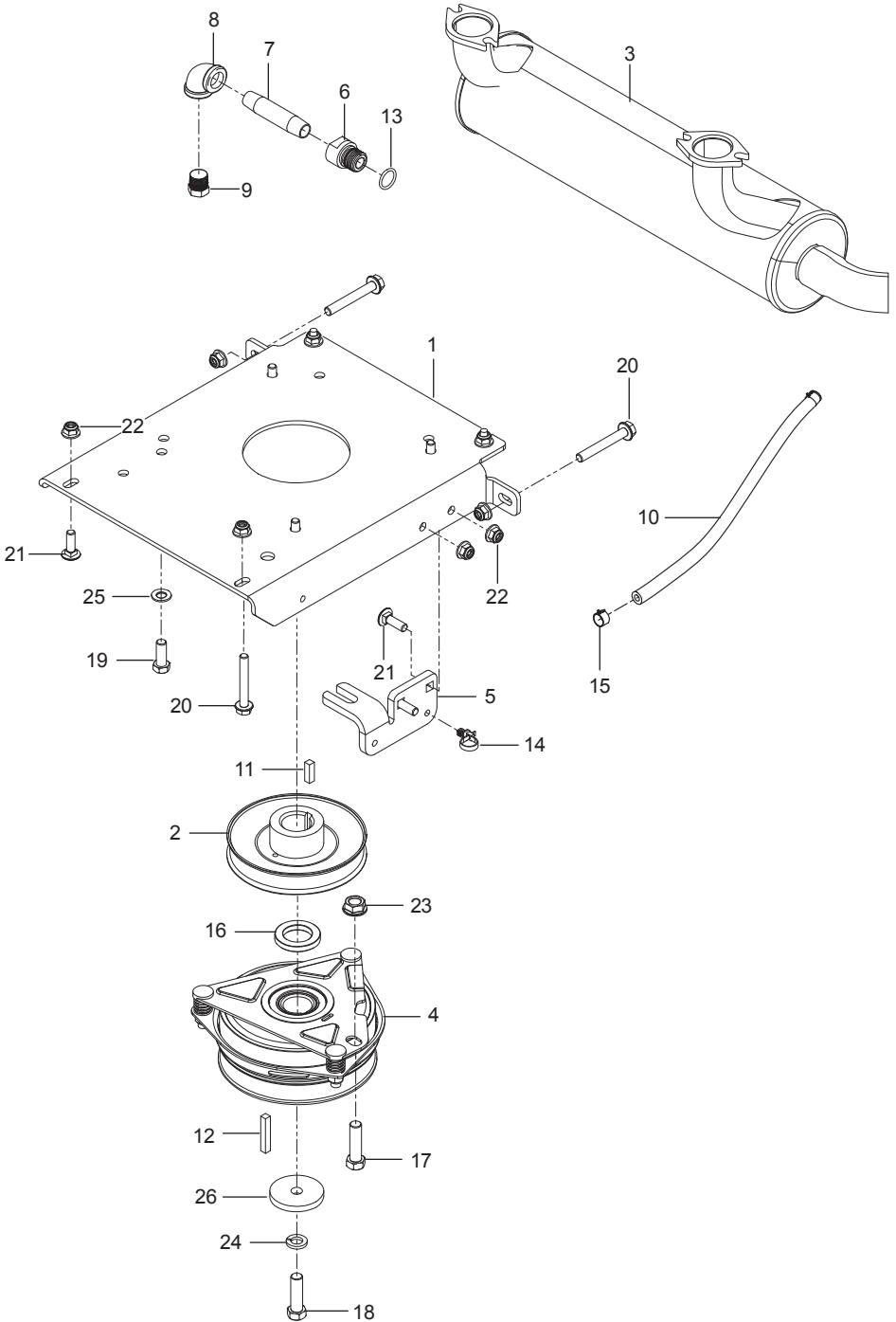

Ref.	Part No.	Qty	Description
1	510 00 46-02	1	Plate, Engine
2	510 01 98-01	1	Pulley, Engine
3	525 75 03-01	1	Muffler
4	539 11 34-37	1	Clutch, GT 2.5
5	522 67 67-02	1	Stop, Clutch
6	539 11 96-80	1	Adaptor, Oil Drain
7	539 11 89-11	2	Pipe 3/8 NPT x 3"
8	539 10 50-72	1	Elbow 90°
9	522 83 70-01	1	Plug 3/8 NPTF Drain
10	587 04 48-14	1	Fuel Line 14"
11	539 10 53-08	1	Key 1/4 Square x 1
12	539 91 02-10	1	Key 1/4 Square x 2
13	539 10 96-18	1	O-Ring
14	505 28 00-01	1	Tie Wrap w/ Clip
15	532 12 34-87	1	Clamp, Hose
16	525 31 39-01	1	Spacer
17	539 10 48-67	1	Bolt 7/16-20 x 1 Hex Head
18	581 33 28-01	1	Bolt 7/16-20 x 1-1/2 Hex Head
19	539 99 05-63	4	Bolt 3/8-16 x 1 Hex Head
20	574 23 38-01	3	Bolt 5/16-18 x 2-1/4 Hex Flange Head
21	539 99 02-08	3	Bolt 5/16-18 x 1 Round Head Square Neck
22	539 11 28-99	8	Nut 5/16-18 Hex Flange Nyloc
23	539 10 25-82	1	Nut 7/16-14 Hex Whiz Lock
24	539 99 02-47	1	Washer 7/16 Slotted Lock
25	539 10 25-93	4	Washer 3/8 Spring
26	539 12 56-26	1	Washer, Heavy
	NOT SHOWN		
	525 55 42-01	1	Engine Harness, Kaw
	574 82 58-01	1	Kit, Spark Arrestor
	586 83 97-01	2	Gasket, Exhaust
	-----	1	Engine, Kawasaki FX751V 24.5 Hp For Engine Replacement Parts, See a Kawasaki Dealer

STEERING

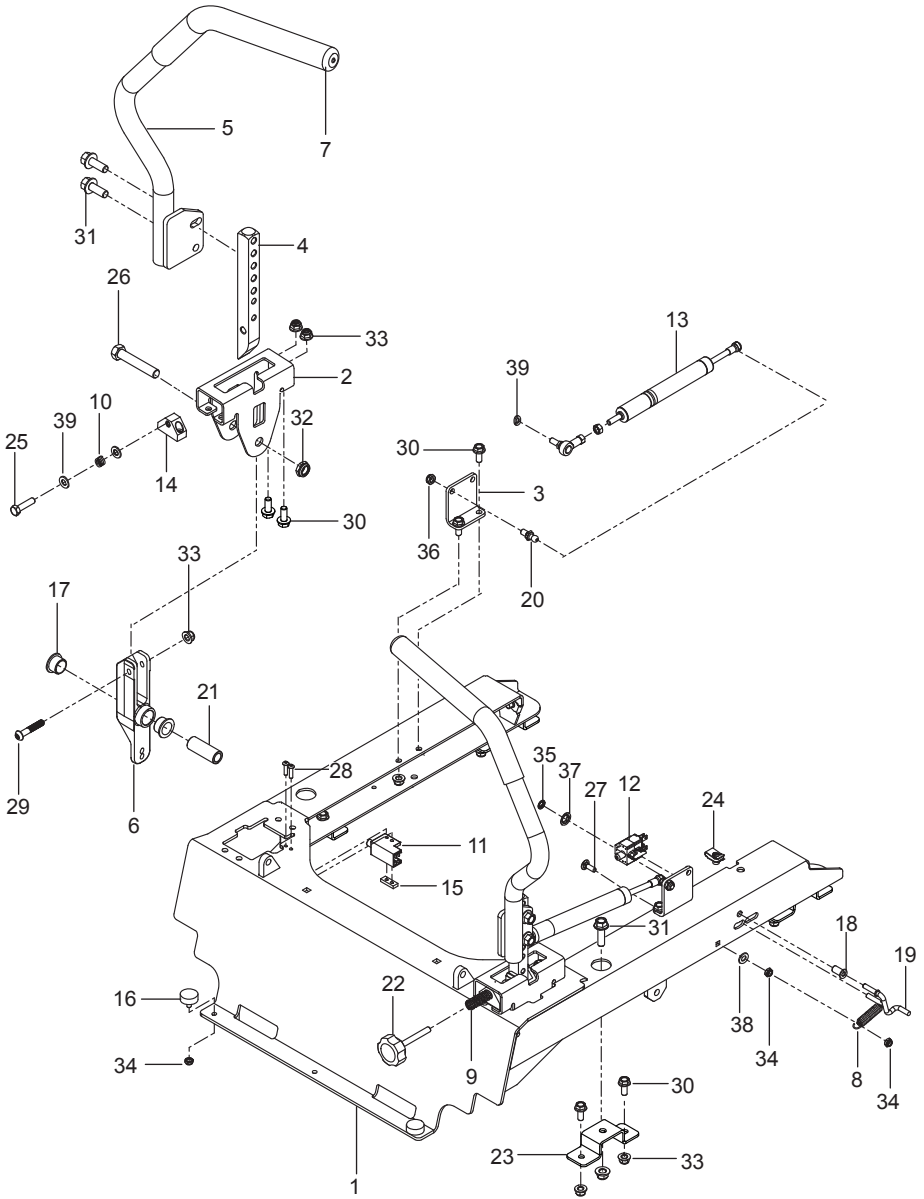

Ref.	Part No.	Qty	Description
1	577 32 77-02	1	Frame, Seat Mount Orange
2	586 73 72-02	2	Bracket, Control
3	577 26 58-01	2	Bracket, Dampener
4	574 26 94-01	2	Lever, Motion
5	577 04 24-03	1	Lever, w/ Grip, Right
	577 04 23-03	1	Lever, w/ Grip, Left
6	576 14 03-02	2	Lever, Control
7	539 13 08-94	2	Grip, Lever
8	539 02 00-35	1	Spring
9	576 85 03-01	1	Spring
10	539 10 28-45	1	Spring
11	539 10 95 53	2	Switch N.c.
12	539 11 37-92	1	Switch, Brake (3-Pole)
13	516 02 03-01	2	Assembly, Dampener
14	581 43 75-01	2	Block, Tracking
15	539 13 15-19	2	Plate, Tapped
16	575 81 15-01	2	Bumper
17	539 13 15-18	4	Bearing, Flanged
18	511 59 49-01	1	Bushing 1/4 Flange
19	511 59 50-01	1	Link, Switch
20	539 11 06-07	2	Ball Stud 10Mm
21	577 25 24-01	2	Spacer, Pivot
22	539 13 17-99	1	Knob
23	522 84 97-02	4	Mount, Black
24	539 10 47-63	4	Retainer, U Type
25	874 78 05-20	1	Bolt 5/16-18 x 1-1/4 Hex Head Tap
26	874 78-08 44	2	Bolt 1/2-13 x 2-3/4 Hex Head
27	872 11 04-06	1	Bolt 1/4-20 x 3/4 Round Head Square Neck Grade 2
28	574 82 27-01	4	Screw 10-24 x 3/4 Socket Head
29	576 85 04-02	2	Screw 5/16-18 x 1-3/4 Button Head
30	874 49 05-12	20	Bolt 5/16-18 x 3/4 Hex Flange Head
31	525 61 28-01	4	Bolt 3/8-16 x 1 Hex Flange Head
32	539 10 80-10	2	Nut 1/2-13 Hex Jam Nyloc Grade 2
33	539 11 28-99	20	Nut 5/16-18 Hex Flange Nyloc
34	539 10 81-20	4	Nut 1/4-20 Hex Thin Nyloc
35	539 10 22-34	1	Nut 1/4 Push
36	873 80 05-00	2	Nut 5/16-18 Hex Nyloc
37	539 91 38-47	2	Nut 3/8 Retainer
38	819 11 11-16	3	Washer 5/16 SAE Flat
39	810 03 05-00	2	Washer 5/16 Slotted Lock

IGNITION SYSTEM

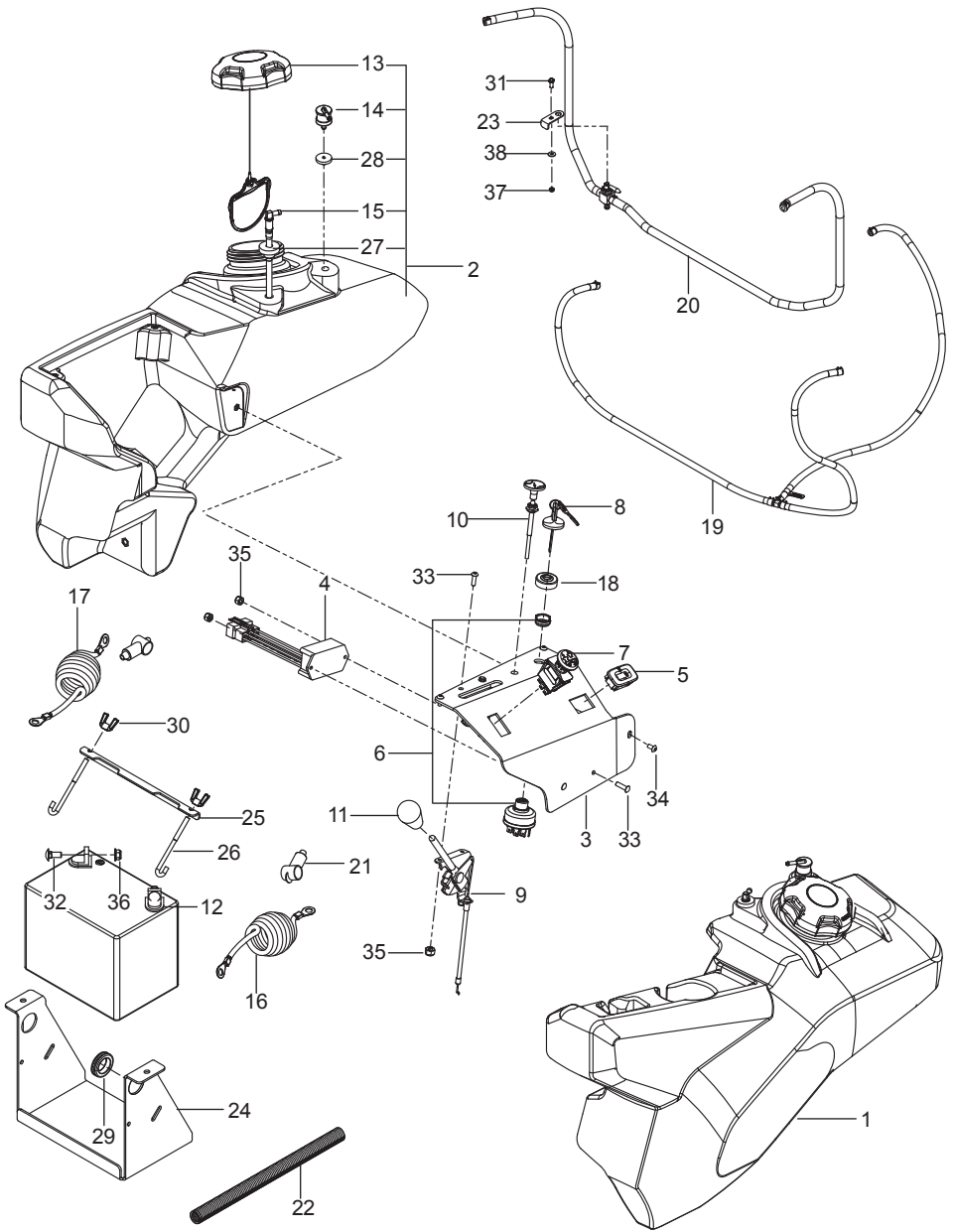

Ref.	Part No.	Qty	Description
1	584 28 03-01	1	Assembly, Tank Left Gry
2	584 28 04-01	1	Assembly, Tank Right Gry
3	529 28 02-02	1	Panel, Control Gry
4	574 51 40-01	1	Timer, Seat
5	586 16 18-01	1	Meter, Service
6	574 45 54-01	1	Switch, Ignition
7	539 13 16-27	1	Switch, PTO 10 Amp
8	574 45 55-01	1	Key, Ignition
9	574 20 70-01	1	Control, Throttle
10	574 20 69-01	1	Cable, Choke
11	539 13 26-24	1	Knob
12	539 10 24-36	1	Battery
13	575 01 81-01	2	Cap w/ Tether, Fuel
14	576 61 81-01	2	Valve, Fuel Check
15	525 86 54-01	2	Fitting, Fuel
16	522 71 87-01	1	Cable, Positive
17	522 71 07-01	1	Cable, Negative
18	539 10 31-78	1	Cap, Ignition Switch
19	587 59 34-01	1	Assembly, Vapor Line
20	577 15 05-01	1	Assembly, Fuel Line
21	539 10 27-59	2	Insulator
22	579 57 97 01	1	Loom 5/8 Split
23	587 18 14-04	1	Bracket, Valve
24	510 02 99-02	1	Bracket, Battery Black
25	510 03 00-01	1	Bracket, Battery Mount
26	510 06 40-01	2	J Hook
27	539 10 52-45	2	Grommet, Rubber
28	576 61 82-01	2	Grommet, Check Valve
29	539 10 59-74	1	Grommet
30	539 99 09-97	2	Wingnut 1/4-20 Nyloc
31	539 99 05-80	1	Bolt 1/4-20 x 3/4 Hex Head
32	872 14 05-06	2	Bolt 5/16-18 x 3/4 Round Head Square Neck
33	574 82 27-01	4	Screw 10-24 x 3/4 Socket Head
34	539 11 43-41	3	Screw 10-24 x 3/8 Socket Head
35	539 97 69-77	4	Nut 10-24 Hex Nyloc
36	539 11 28-99	2	Nut 5/16-18 Hex Flange Nyloc
37	539 10 81-20	1	Nut 1/4-20 Hex Thin Nyloc
38	539 99 05-98	1	Washer 1/4 Flat
	NOT SHOWN		
	510 09 36-01	1	Harness, Wiring

PARKING BRAKE

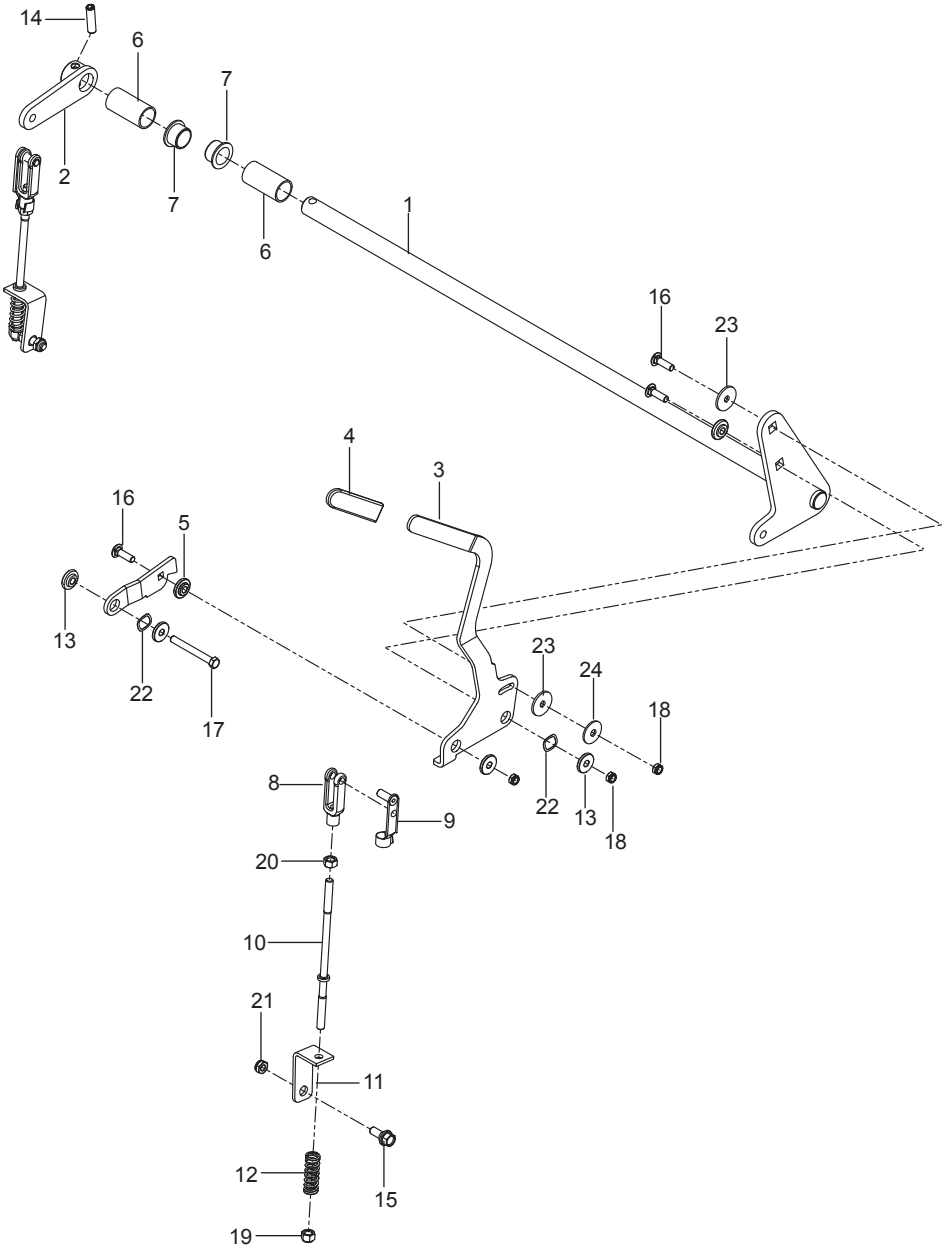

Ref.	Part No.	Qty	Description
1	576 41 63-01	1	Shaft, Brake
2	576 41 64-01	1	Arm, Right Brake
3	515 98 00-02	1	Lever, Brake
4	539 97 65-26	1	Grip, Lever
5	515 98 03-01	1	Link, Follower
6	576 76 40-01	2	Spacer, Shaft
7	539 13 15-18	2	Bearing, Flange
8	539 97 64-81	2	Yoke
9	522 70 59-01	2	Pin 3/8 Clevis Spring
10	576 45 95-01	2	Linkage, Brake
11	575 22 98-02	2	Bracket, Brake
12	575 23 03-01	1	Spring
13	539 13 21-61	6	Bushing, Brake
14	539 11 06-31	1	Roll Pin 5/16" Dia.
15	539 11 03-03	2	Bolt 5/16 Shoulder
16	539 10 04-13	3	Bolt 3/8-16 x 1-1/4 Round Head Square Neck
17	874 78 06-52	1	Bolt 3/8-16 x 3-1/4 Hex Head
18	539 20 02-82	3	Nut 3/8-16 Hex Jam Nyloc
19	539 11 09-43	2	Nut 5/16-24 Hex Nyloc
20	539 99 02-23	2	Nut 5/16-24 Hex
21	539 11 56-17	2	Nut 5/16-18 Hex Nyloc
22	539 13 30-07	2	Washer, Wave
23	525 49 09-01	2	Washer, Friction
24	539 91 20-63	1	Washer, Cone

HYDRAULIC PUMP-MOTOR

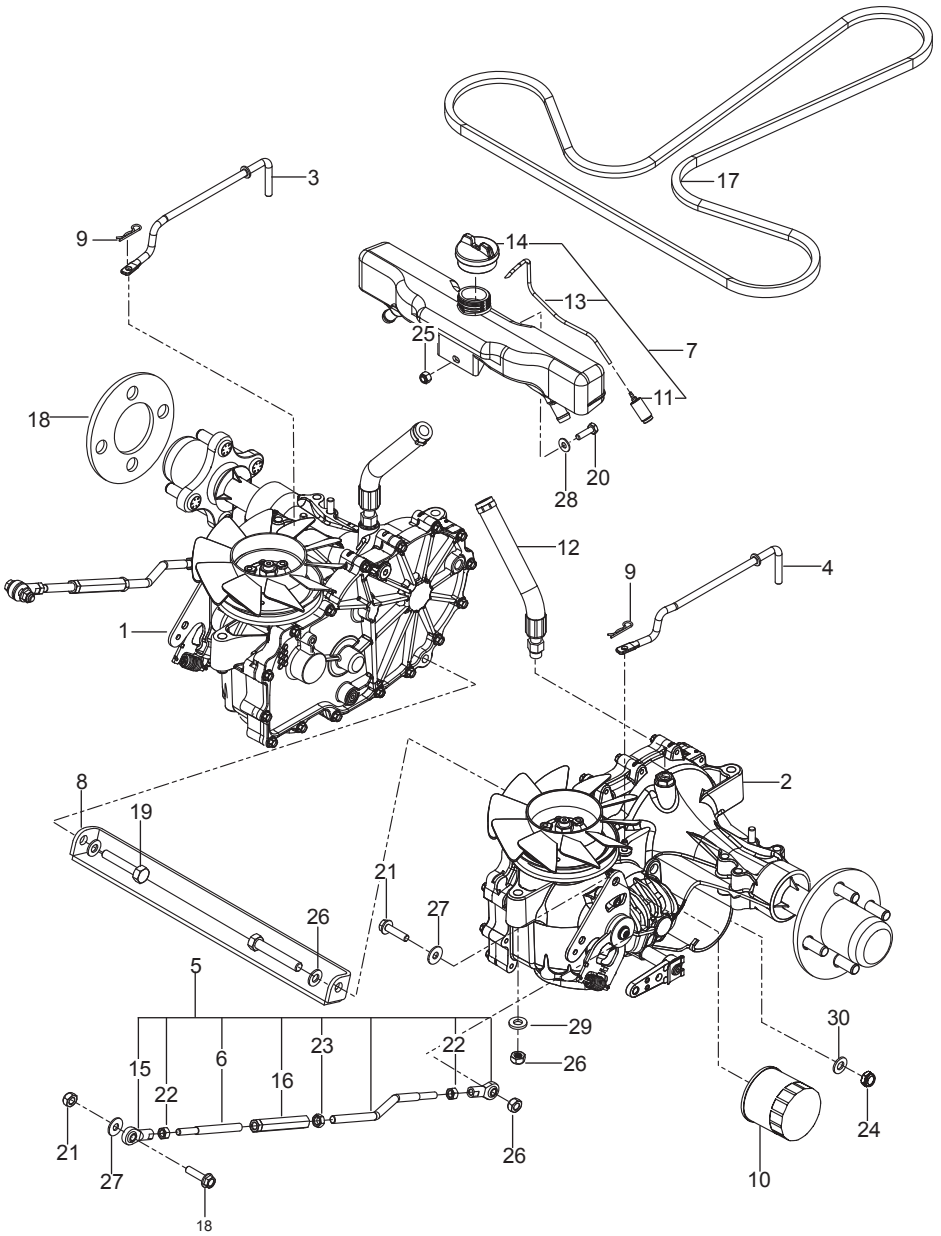

Ref.	Part No.	Qty	Description
1	574 56 91-02	1	Trans, ZT-3400, Right
2	574 56 91-01	1	Trans, ZT-3400, Left
3	539 13 16-18	1	Linkage, Right Bypass
4	539 13 16-16	1	Linkage, Left Bypass
5	576 41 57-01	2	Assembly, Linkage, Control
6	522 55 92-01	2	Linkage, Control
7	585 31 82-01	1	Assy, Expansion Tank
8	851 82 02-02	1	Bracket
9	539 97 69-88	2	Hairpin Cotter
10	539 11 34-66	2	Filter, Hydro
11	530 09 56-46	1	Filter
12	574 89 21-01	2	Hose, Expansion
13	586 06 75-01	1	Hose, Fuel Line
14	586 07 27-01	1	Cap, Tank
15	539 10 25-90	4	Ball End, Right
16	539 10 91-49	2	Turnbuckle 3/8
17	576 66 72-01	1	Belt
18	580 90-62-02	2	Spacer, Wheel
19	539 10 85-51	2	Bolt 3/8-16 x 2-1/4 Hex Head Grade 8
20	539 99 06-42	1	Bolt 1/4-20 x 7/8 Hex Head
21	525 54 40-01	4	Bolt 5/16-18 x 1-1/4 Self Tap
22	539 99 02-23	4	Nut 5/16-24 Hex
23	539 10 87-32	2	Nut 3/8-24 Hex Jam
24	581 84 81-01	2	Nut 3/8-16 Lock Grade C
25	539 97 69-78	1	Nut 1/4-20 Hex Nyloc
26	585 47 68-01	4	Nut 5/16-18 Hex Lock
27	539 99 06-92	4	Washer 5/16 Std Flat
28	539 99 00-55	1	Washer 1/4 SAE Flat
29	585 47 70-01	2	Washer 5/16 SAE Flat
30	539 99 01-22	4	Washer 3/8 SAE Flat

HYDRAULIC FRAME

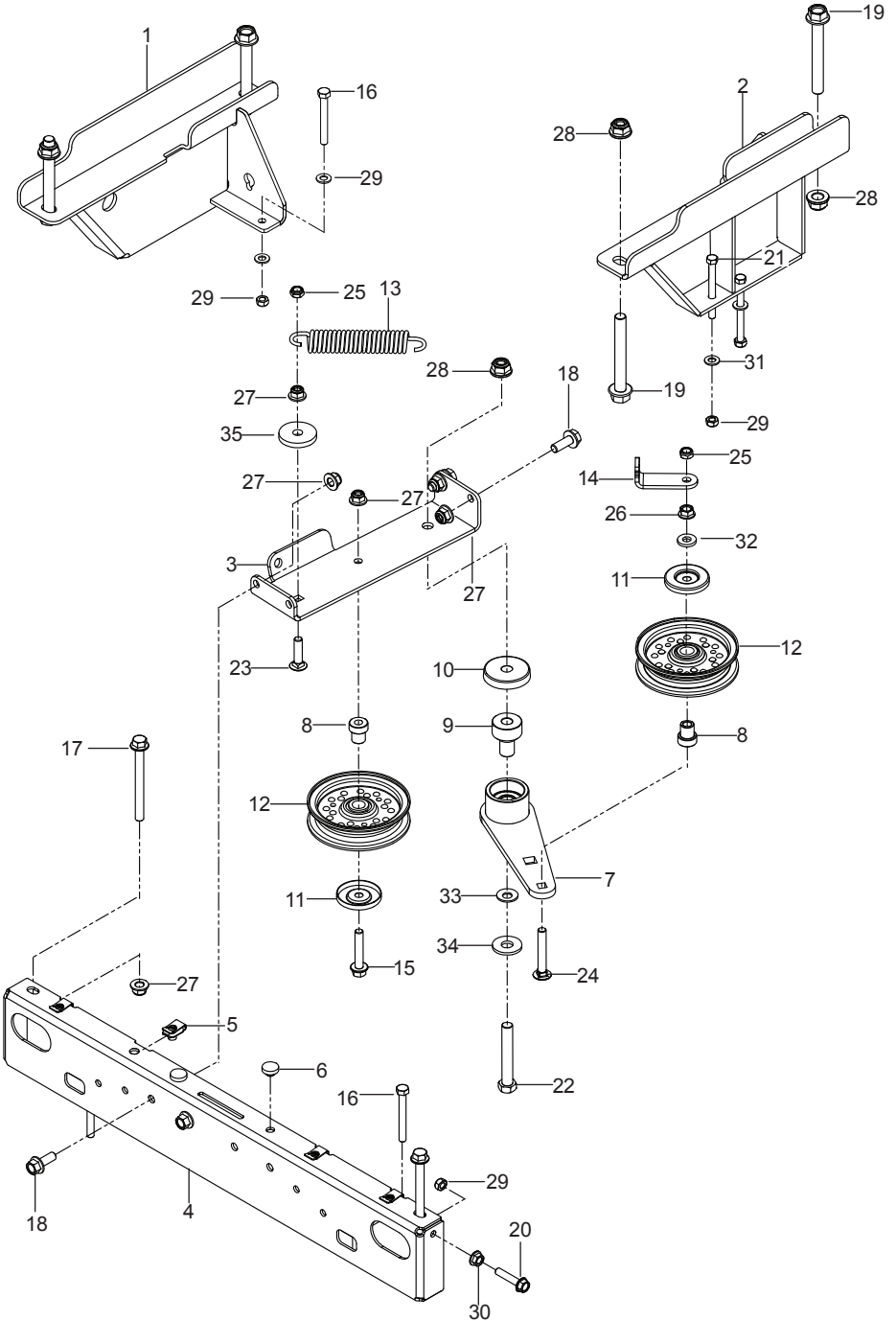

Ref.	Part No.	Qty	Description
1	581 82 13-02	1	Mount, Trans Right Black
2	581 82 12-02	1	Mount, Trans Left Black
3	576 45 99-02	1	Mount, Idler Black
4	581 81 30-02	1	Mount, Ft Black
5	539 10 47-63	4	Retainer, U Type
6	539 10 25-87	2	Grommet, Bumper
7	510 04 16-03	1	Arm, Idler w/ Bearings
8	525 43 56-01	2	Pivot, Idler
9	510 20 63-01	1	Pivot, Bearing
10	539 11 46-62	1	Shield, Dust
11	510 25 45-01	2	Shield, Dust
12	539 97 66-88	2	Pulley, Idler
13	575 47 09-01	1	Spring, Extension
14	576 45 98-01	1	Bracket, Spring
15	874 49 06-32	1	Bolt 3/8-16 x 2 Hex Flange Head
16	585 47 66-01	4	Bolt 5/16-18 x 2-1/2 Hex Head
17	521 99 66-01	2	Bolt 3/8-16 x 4 Hex Flange Head
18	525 61 28-01	4	Bolt 3/8-16 x 1 Hex Flange Head
19	525 54 48-01	4	Bolt 1/2-13 x 4 Hex Flange Head Gr 8
20	525 46 54-01	4	Bolt 5/16-18 x 1-1/2 Hex Flange Head
21	585 47 67-01	4	Bolt 5/16-18 x 3 Hex Head
22	539 10 34-33	1	Bolt 1/2-13 x 3-1/4 Hex Head
23	539 10 93-45	1	Bolt 3/8-16 x 1-1/2 Round Head Square Neck
24	539 12 81-01	1	Bolt 3/8-16 x 2-1/2 Carriage
25	539 20 02-82	2	Nut 3/8-16 Hex Jam Nyloc
26	539 99 06-13	1	Nut 3/8-16 Hex Whiz Lock
27	521 99 65-01	8	Nut 3/8-16 Hex Flange Nyloc
28	521 99 11-01	5	Nut 1/2-13 Hex Flange Nyloc
29	585 47 68-01	5	Nut 5/16-18 Hex Lock
30	539 99 05-85	1	Nut 5/16-18 Hex Whiz Lock
31	585 47 70-01	3	Washer 5/16 SAE Flat
32	522 02 34-01	1	Washer 3/8 Thick
33	539 11 55-28	1	Washer 1/2 Belleville
34	539 10 95-54	1	Washer 1/2 Flat
35	539 10 65-04	1	Washer, Heavy

WHEELS & TIRES

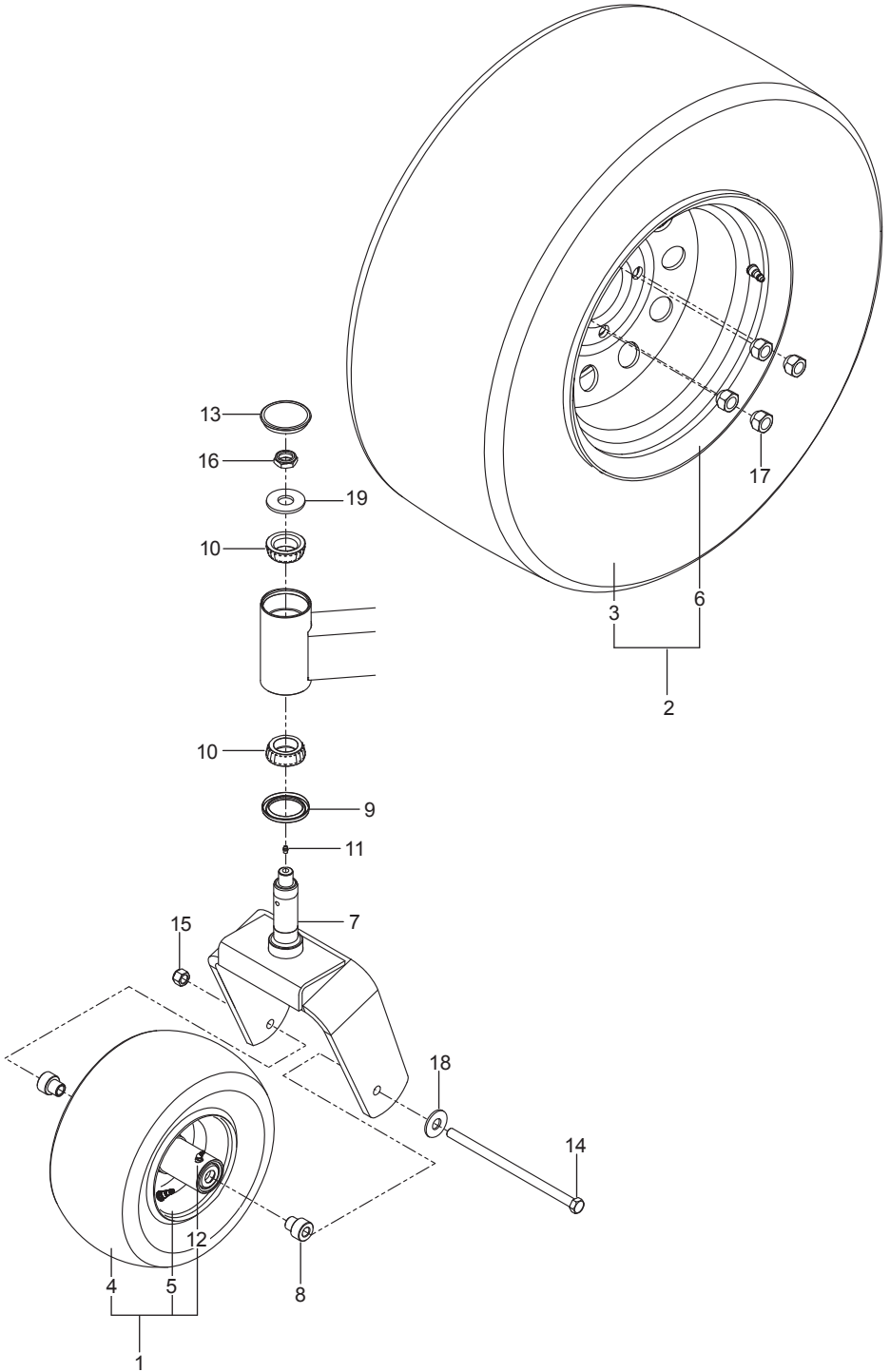

Ref.	Part No.	Qty	Description
1	539 10 55-21	2	Assembly, Tire 13 x 6.5
2	522 90 51-01	2	Assembly, Tire 23 x 10.5
3	539 10 74-31	2	Tire 23 x 10.5 Turf Master
4	539 10 55-22	2	Tire 13 x 6.50 4 Ply
5	539 10 55-23	2	Rim
6	522 90 51-02	2	Rim
7	525 61 19-02	2	Yoke, Caster, Orange
8	539 10 55-18	4	Spacer, Axle
9	510 03 43-01	2	Seal, Bearing
10	510 03 44-03	4	Cone
11	539 10 14-74	2	Zerk
12	539 10 33-00	2	Zerk 1/4 -28 Angled
13	510 03 40-01	2	Cap, Dust
14	539 10 55-17	2	Bolt 1/2-13 x 9-1/2 Hex Head
15	873 93 08-00	2	Nut 1/2-13 Hex Center Lock
16	522 84 26-01	2	Nut 3/4-16 Hex Thin Nyloc
17	539 10 11-73	8	Nut, Lug
18	539 99 02-50	4	Washer 1/2 SAE
19	574 82 47-01	2	Washer 3/4 Hardened

MOWER LIFT / DECK LIFT

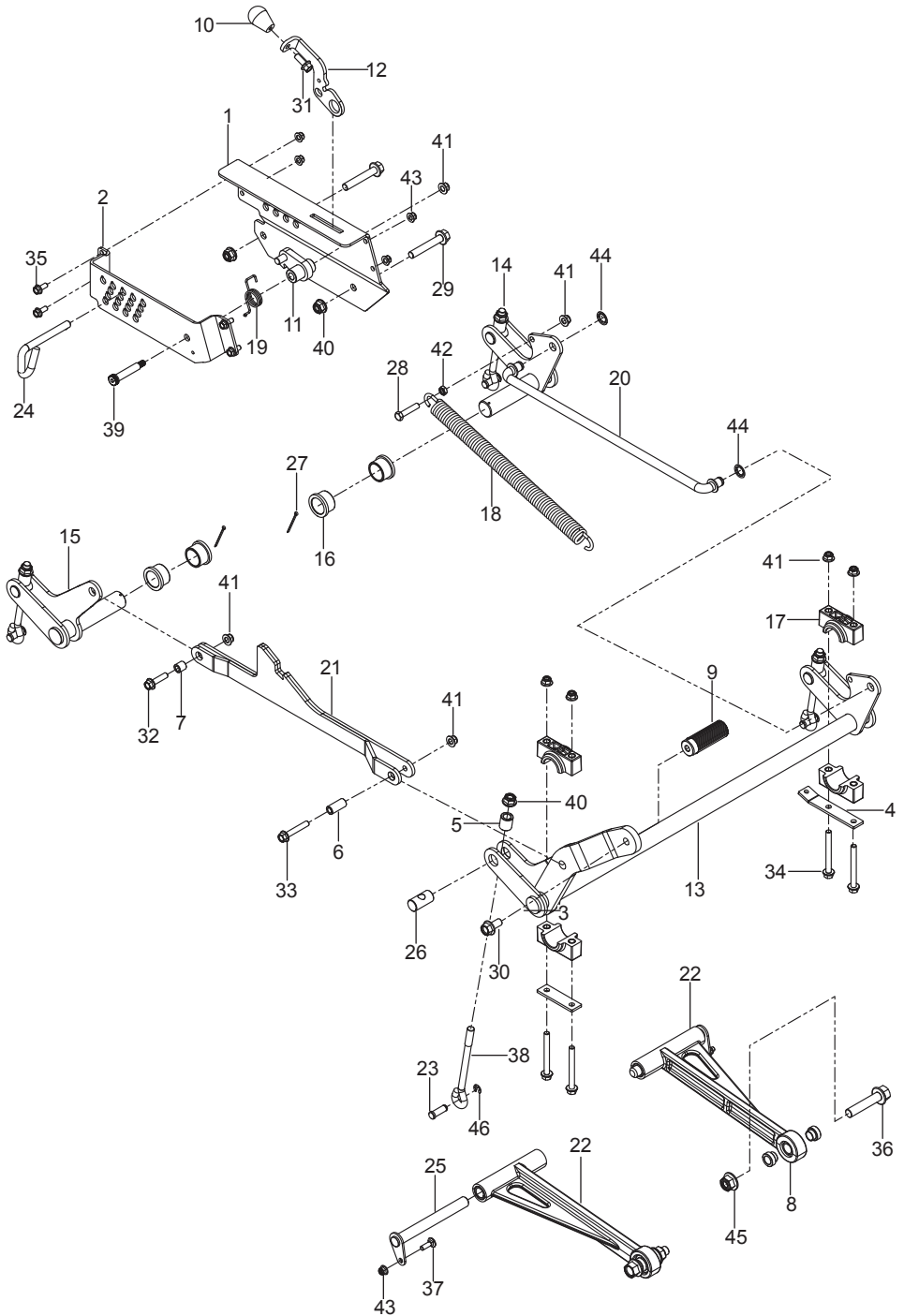

Ref.	Part No.	Qty	Description
1	576 48 00-02	1	Plate, Height, Inner Orange
2	576 48 01-02	1	Plate, Height, Outer Orange
3	525 82 22-01	1	Plate, Pillow Block
4	576 64 67-01	1	Plate, Spring Anchor
5	576 48 58-01	4	Spacer, Eyebolt
6	576 62 31-01	1	Spacer, Front Lift Strap
7	576 62 30-01	1	Spacer, Rear Lift Strap
8	510 36 25-01	4	Spacer, Strut
9	510 40 83-01	1	Pedal, Deck Height
10	539 13 26-24	1	Knob
11	510 40 68-01	1	Latch, Transport
12	576 63 89-01	1	Lever, Release
13	576 47 92-01	1	Shaft, Deck Lift Front
14	576 47 99-01	1	Shaft, Lift Left Rear
15	576 47 94-01	1	Shaft, Lift Right Rear
16	510 08 94-01	4	Bushing, Flanged
17	510 02 39-02	4	Block, Pillow
18	576 67 66-01	1	Spring, Extension
19	510 37 66-01	1	Spring, Torsion
20	510 08 98-01	1	Rod, Lift
21	576 62 26-01	1	Strap, Deck
22	510 10 65-01	2	Assembly, Strut
23	510 09 01-01	4	Pin 7/16 Clevis
24	510 01 65-01	1	Pin, Height
25	515 98 82-01	2	Pin, Strut
26	576 48 56-01	4	Pin, Trunion
27	539 10 28-89	2	Pin 1/8 x 2 Cotter
28	539 99 07-30	1	Bolt 3/8-16 x 1-3/4 Hex Head
29	874 49 08-48	2	Bolt 1/2-13 x 3 Hex Flange Head
30	574 21 06-01	1	Bolt 1/2-13 x 1 Hex Flange Head
31	525 61 28-01	1	Bolt 3/8-16 x 1 Hex Flange Head
32	576 62 16-01	1	Bolt 3/8-16 x 1-1/2 Hex Flange Head
33	874 49 06-36	1	Bolt 3/8-16 x 2-1/4 Hex Flange Head
34	874 49 06-52	4	Bolt 3/8-16 x 3-1/2 Hex Flange Head
35	874 49 05-12	4	Bolt 5/16-18 x 3/4 Hex Flange Head
36	874 45 10-48	2	Bolt 5/8-11 x 3 Hex Flange Head Gr 8
37	539 99 02-08	2	Bolt 5/16-18 x 1 Round Head Square Neck
38	576 47 90-01	4	Eyebolt, Deck Lift
39	516 03 55-01	1	Bolt 3/8-16 x 2-1/4 Shoulder
40	521 99 11-01	6	Nut 1/2-13 Hex Flange Nyloc
41	521 99 65-01	8	Nut 3/8-16 Hex Flange Nyloc
42	539 10 93-32	1	Nut 3/8-16 Hex Jam
43	539 11 28-99	6	Nut 5/16-18 Hex Flange Nyloc
44	539 10 93-04	2	Nut 5/8 Push
45	525 82 91-01	2	Nut 5/8-11 Flange Nyloc
46	522 70 52-01	4	E Ring 7/16

MOWER DECK / CUTTING DECK

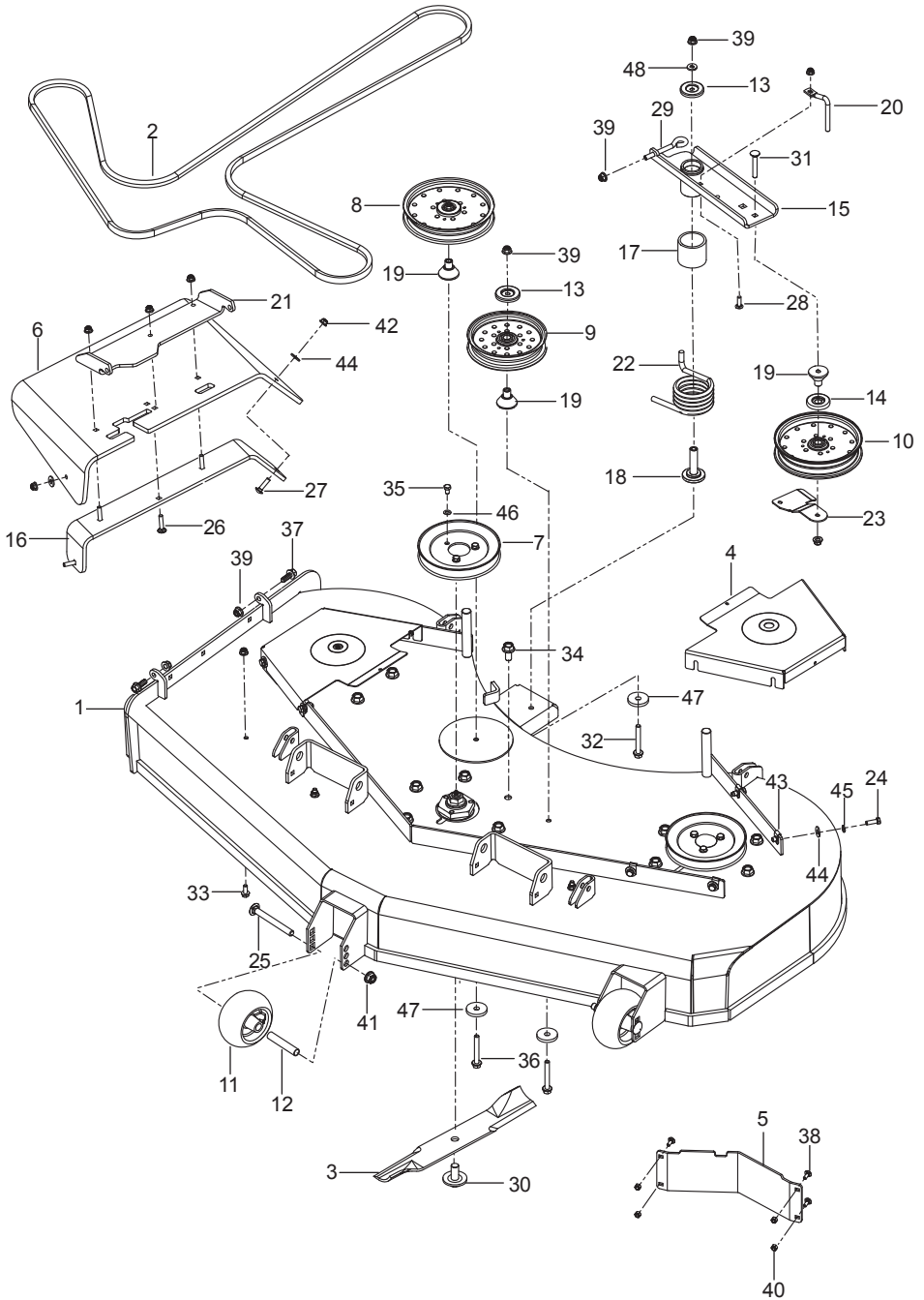

Ref.	Part No.	Qty	Description
1	588 12 76-05	1	Deck w/ Safety Decals
2	575 65 84-01	1	Belt
3	581 05 55-02	3	Blade
4	510 13 12-02	2	Belt Shield
5	510 43 75-02	1	Baffle Diverter Left
6	525 48 58-01	1	Chute, Discharge
7	521 97 97-01	3	Pulley
8	525 59 82-01	1	Pulley, Idler 7" Narrow
9	510 01 96-01	1	Puller, Idler 6" Narrow
10	510 01 51-01	1	Pulley, Idler 7"
11	574 16 96-01	2	Roller, Gauge
12	574 19 64-01	2	Tube Roller Axle
13	510 25 45-01	3	Shield Dust
14	510 26 22-01	1	Shield, Dust
15	574 72 22-01	1	Arm, Idler w/ Spacer, Bearings
16	525 48 60-02	1	Support, Bracket Black
17	525 46 56-01	1	Spacer, Idler Pivot
18	522 72 97-01	1	Bearing, Idler Pivot
19	510 26 37-01	3	Bearing, Idler Arm
20	574 26 22-01	1	Belt Keeper
21	574 19 70-02	1	Bracket, Chute Pivot Black
22	525 31 09-01	1	Spring, Torsion, Idler
23	574 26 21-02	1	Belt Guide, Black
24	874 78 05-16	8	Screw 5/16-18 x 1 Hex
25	510 02 23-01	2	Bolt 1/2-13 x 4-3/4 Round Head Square Neck
26	539 10 29-33	3	Bolt 5/16-18 x 1-1/2 Round Head Square Neck
27	539 10 04-72	2	Bolt 5/16-18 x 1-1/4 Round Head Square Neck
28	872 11 05-08	1	Bolt 5/16-18 x 1 Round Head Square Neck
29	574 20 20-01	1	Eye Bolt
30	539 11 90-07	3	Blade Bolt
31	539 12 81-01	1	Bolt 3/8-16 x 2-1/2 Carriage
32	874 88 06-72	1	Bolt 3/8-16 x 4-1/2 Hex Head
33	874 49 05-12	4	Bolt 5/16-18 x 3/4 Hex Flange Head
34	574 21 06-01	18	Bolt 1/2-13 x 1 Hex Flange Head
35	539 13 03-15	9	Bolt 5/16-18 x 1/2 Hex Head
36	874 49 06-44	2	Bolt 3/8-16 x 2-3/4 Hex Flange Head
37	525 61 28-01	2	Bolt Washer Head 3/8-16 x 1
38	539 11 56-20	4	Bolt 1/4-20 x 3/4 Carriage
39	521 99 65-01	5	Nut 3/8-16 Hex Flange Nyloc
40	539 97 69-78	4	Nut 1/4-20 Hex Nyloc
41	521 99 11-01	2	Nut 1/2-13 Hex Flange Nyloc
42	539 11 28-99	9	Nut 5/16-18 Hex Flange Nyloc
43	539 10 47-63	8	Retainer, U Type
44	819 12 14-14	10	Washer 5/16 Std Flat
45	810 03 05-00	8	Washer 5/16 Slotted Lock
46	539 10 96-00	9	Washer 5/16 Disc Spring
47	539 10 65-04	3	Washer, Heavy
48	522 02 34-01	1	Washer 3/8 Thick

BLADESHAFT

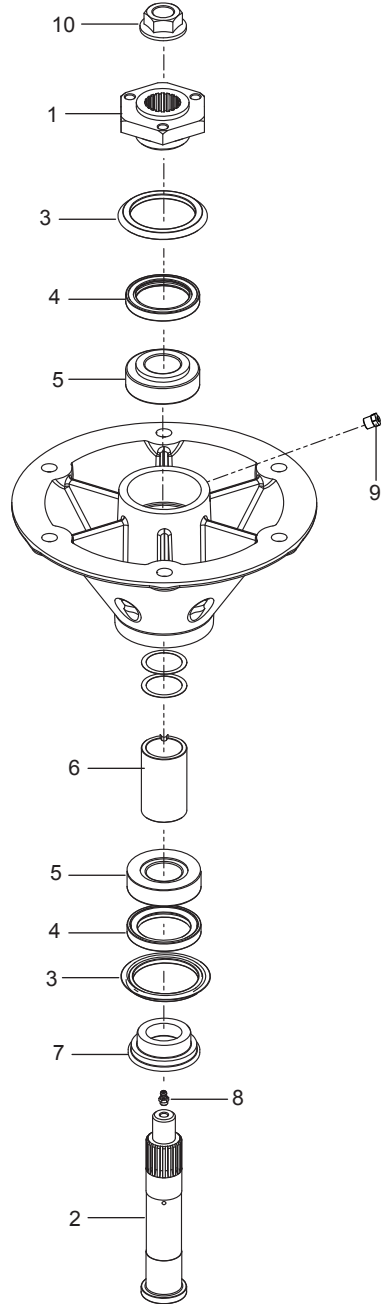
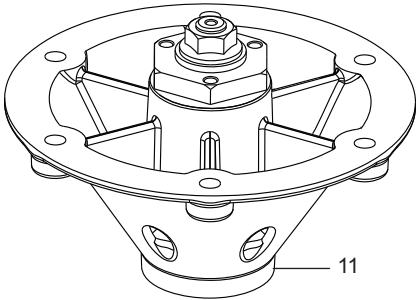

Ref.	Part No.	Qty	Description
1	580 94 22-01	3	Hub
2	580 94 21-01	3	Shaft, Spindle
3	580 94 27-01	3	Seal, V Ring
4	580 94 26-01	6	Seal, Shaft
5	580 94 18-01	6	Bearing, Tapered
6	580 94 23-01	3	Spacer
7	580 94 25-01	3	Carrier, Seal
8	539 97 69-98	3	Zerk
9	539 97 73-26	3	Valve, Grease Poppet
10	539 13 06-53	3	Nut 3/4-16 Hex Flange
11	580 94 33-03	3	Assembly, Spindle
	NOT SHOWN		
	574 75 42-01	1	Kit, Bearing Assembly

When replacing the Spindle bearings,
order the Bearing Assembly Kit to
assure proper installation

SEAT

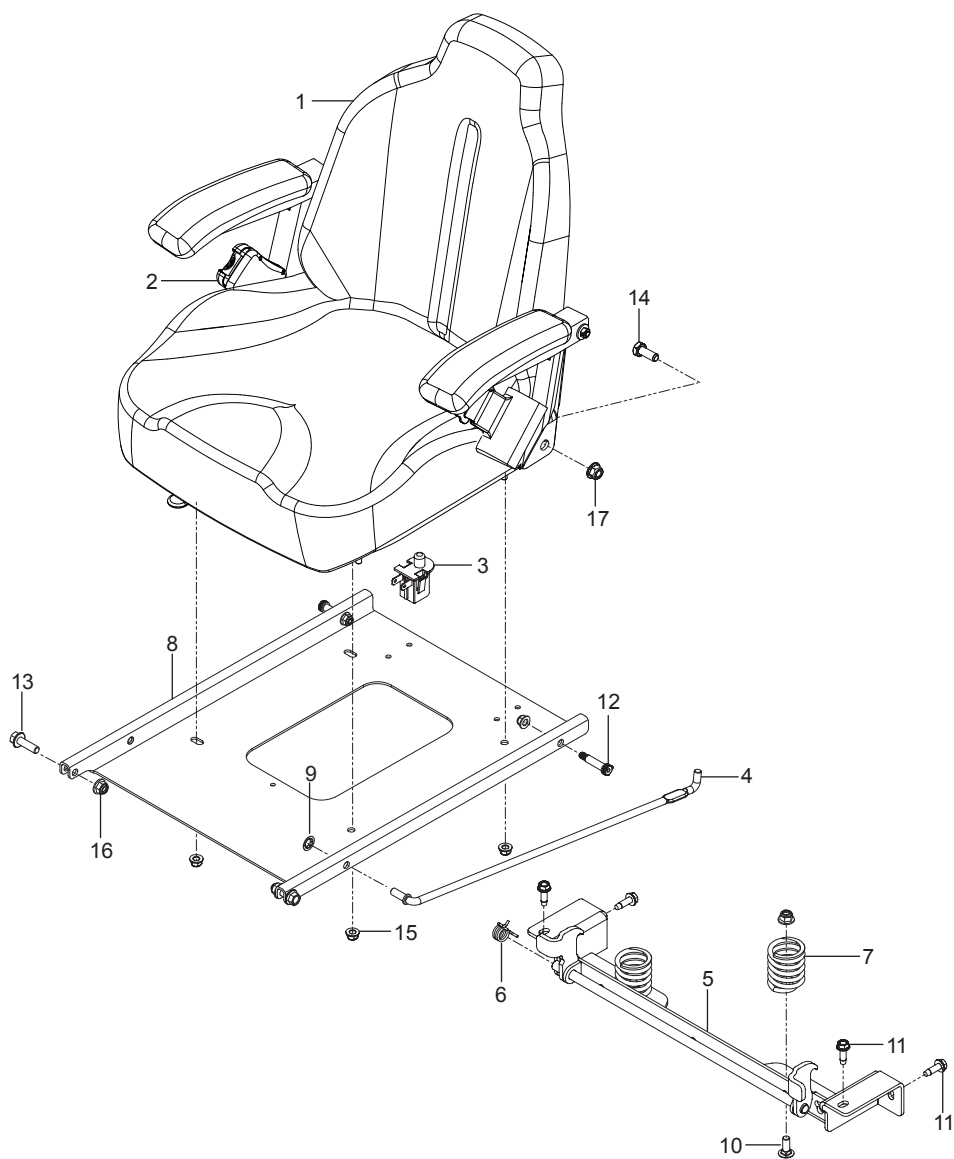

Ref.	Part No.	Qty	Description
1	501 58 04-01	1	Assembly, Seat
2	576 78 34-01	1	Assembly, Seat Belt
3	539 11 97-41	1	Switch, Seat
4	510 06 41-01	1	Rod, Seat
5	585 85 74-02	1	Latch, Seat
6	520 28 31-01	1	Spring, Torsion
7	539 11 03-00	2	Spring, Seat
8	510 03 93-02	1	Pan, Seat
9	539 91 38-47	2	Retainer 3/8 Nut
10	539 99 06-45	2	Bolt 3/8-16 x 1 Round Head Square Neck
11	539 11 32-26	4	Bolt 5/16-18 x 1 Thread Form
12	515 99 06-01	2	Bolt 3/8 x 1-1/4 5/16-18 Shoulder
13	525 83 42-01	2	Bolt 3/8-16 x 1-1/4 Hex Flange Head
14	539 10 01-43	2	Bolt 7/16-14 x 1 Hex Head
15	539 11 28-99	6	Nut 5/16-18 Hex Flange Nyloc
16	521 99 65-01	2	Nut 3/8-16 Hex Flange Nyloc
17	539 13 20-19	2	Nut 7/16-14 Whiz Lock

DECALS

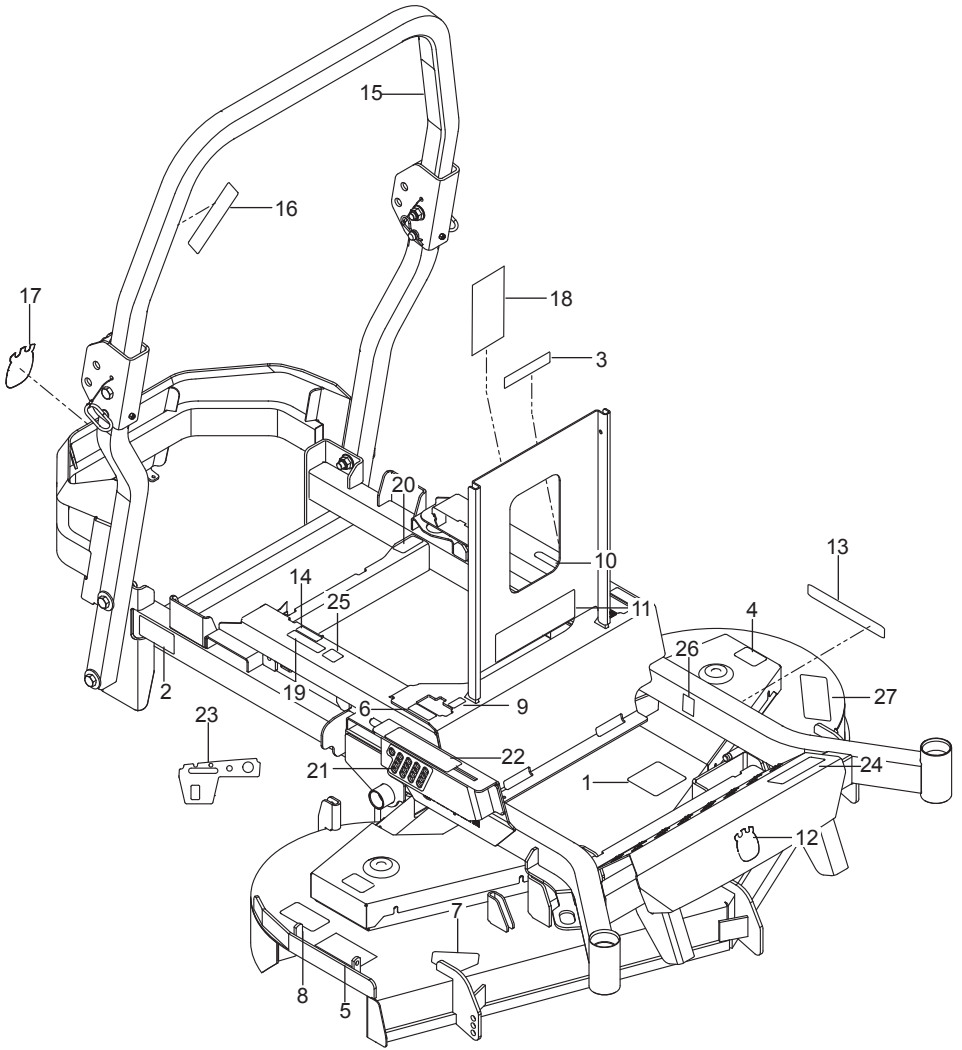

Ref.	Part No.	Qty	Description
1	574 43 73-01	1	Decal, Belt Route
2	539 10 57-44	1	Decal, Belt Drive Warning
3	539 10 57-45	1	Decal, Battery Warning
4	581 72 43-01	2	Decal, No Step
5	539 10 57-46	1	Decal, Severing
6	589 28 30-01	2	Decal, Motion Control
7	584 90 46-01	1	Decal, Blade Warning
8	581 72 44-01	1	Decal, Deflector
9	585 14 26-01	2	Decal, Tracking
10	585 14 88-01	1	Decal, Park Brake
11	583 93 40-01	1	Decal, Warning
12	532 42 86-76	1	Decal, Crown Small
13	532 42 91-96	2	Decal, Husqvarna
14	574 56 94-01	1	Decal, Fuse
15	574 56 90-06	1	Decal, ROPS
16	574 56 90-02	1	Decal, ROPS Warning
17	574 45 50-01	1	Decal, Crown Large
18	585 38 49-01	1	Decal, Service
19	532 42 41-02	1	Decal, Spark Arrestor
20	577 15 01-01	1	Decal, Fuel
21	576 75 53 01	1	Decal, Height
22	576 76 38-01	1	Decal, Release Lever
23	510 24 66-02	1	Decal, Console
24	576 75 52 07	1	Decal, P-ZT54
25	501 08 26-01	1	Decal, ECM Australia
26	581 72 41-02	1	Decal, 80 DBA
27	539 12 13-22	1	Foot Pad

PROTECTION FRAME

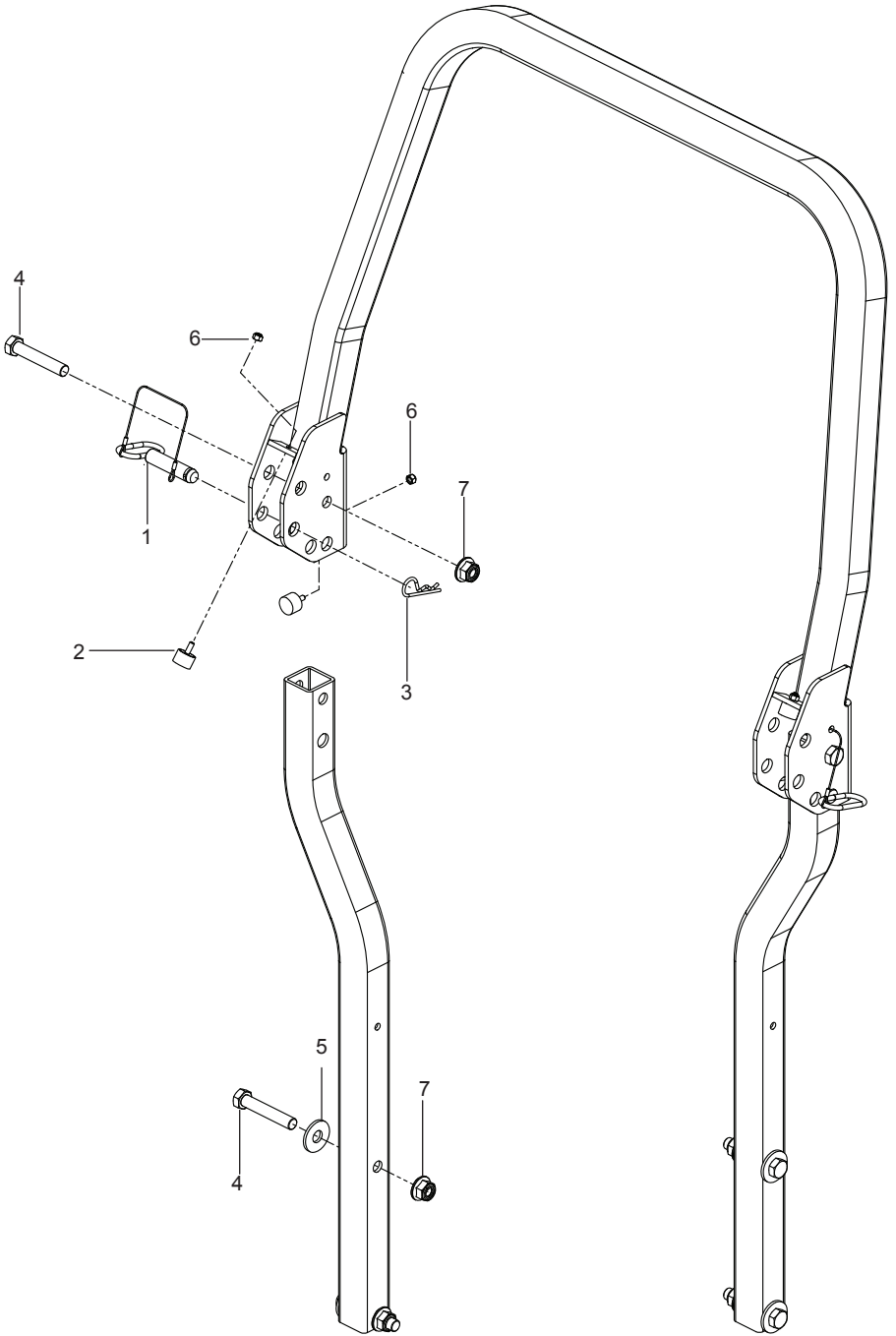

Ref.	Part No.	Qty	Description
1	574 38 80-01	2	Latch Pin w/ Lanyard
2	522 80 14-01	4	Bumper, Male Stud 1/4-20
3	539 20 07-15	2	Pin, Hair
4	580 75 46-01	6	Bolt 5/8-11 x 3-1/2 Hex Head
5	539 10 26-53	4	Washer 5/8 Std Flat
6	873 80 04-00	4	Nut 1/4-20 Hex Nyloc
7	525 82 91-01	6	Nut 5/8-11 Flange Nyloc
	NOT SHOWN		
	576 73 88-01	1	Assembly, ROPS

www.husqvarna.com

115 72 09-28 Rev B
2016-02-01