

ILLUSTRATED PARTS LIST

MODEL NUMBER ST 224

PRODUCT NUMBER 961 93 00-96

MFG. ID. NUMBER 96193009603

REPAIR PARTS

AUGER HOUSING / IMPELLER ASSEMBLY

SNOW THROWER - MODEL NO. ST224 (96193009603), PRODUCT NO. 961 93 00-96

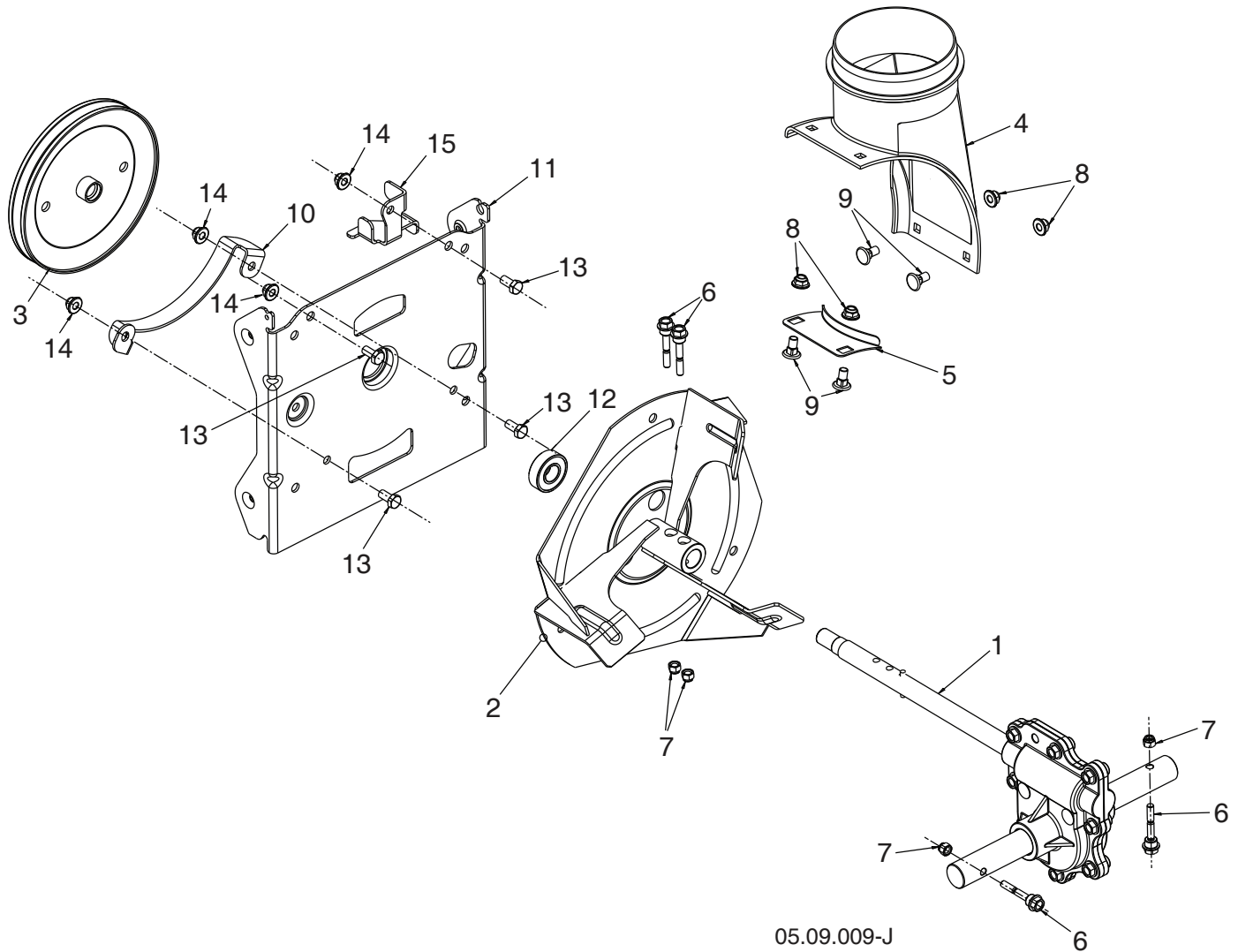

NOTE: All component dimensions given in U.S. inches. 1 inch = 25.4 mm
IMPORTANT: Use only Original Equipment Manufacturer (O.E.M.) replacement parts.
Failure to do so could be hazardous, damage your snow thrower and void your warranty.

REPAIR PARTS

AUGER HOUSING / IMPELLER ASSEMBLY

SNOW THROWER - MODEL NO. **ST224** (96193009603), PRODUCT NO. 961 93 00-96

| KEY NO. | PART NO. | DESCRIPTION |
|---------|--------------|--|
| 1 | 501 14 96-01 | GEARBOX AUGER |
| 2 | 586 60 72-02 | IMPELLER STEEL |
| 3 | 587 40 24-01 | PULLEY IMPELLER – SCREW ON |
| 4 | 585 05 69-01 | CHUTE DISCHARGE BASE |
| 5 | 532 18 40-95 | BRACKET CORNER DISCHARGE BASE |
| 6 | 588 07 75-01 | BOLT SHEAR 1/4-20 |
| 7 | 873 80 04-00 | NUT NYLOCK 1/4-20 |
| 8 | 585 69 13-01 | NUT FLANGE NYLOCK 5/16-18 - BLK |
| 9 | 585 69 12-01 | BOLT CARRIAGE WAFER HEAD 5/16-18 X 5/8 BLK |
| 10 | 581 63 20-02 | BRACKET BELT KEEPER LOWER |
| 11 | 581 59 25-02 | BRACKET INTERFACE |
| 12 | 532 19 87-91 | BEARING BALL |
| 13 | 532 16 31-83 | SCREW HEX HEAD 5/16-18 X 5/8 |
| 14 | 532 42 79-42 | NUT FLANGE NYLOCK 5/16-18 |
| 15 | 587 58 72-02 | LOWER AUGER BELT GUIDE |

NOTE: All component dimensions given in U.S. inches. 1 inch = 25.4 mm
IMPORTANT: Use only Original Equipment Manufacturer (O.E.M.) replacement parts.
Failure to do so could be hazardous, damage your snow thrower and void your warranty.

REPAIR PARTS

AUGER HOUSING / IMPELLER ASSEMBLY

SNOW THROWER - MODEL NO. ST224 (96193009603), PRODUCT NO. 961 93 00-96

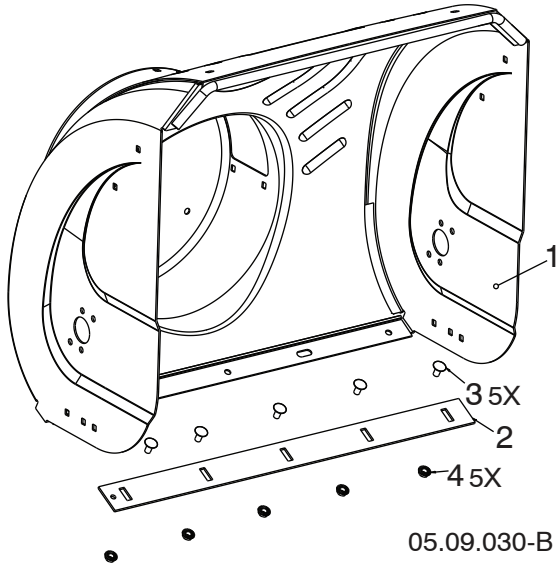

| KEY NO. | PART NO. | DESCRIPTION |
|---------|--------------|----------------------------------|
| 1 | 581 70 83-90 | AUGER HOUSING |
| 2 | 532 40 78-25 | SCRAPER BAR |
| 3 | 872 27 05-05 | CARRIAGE BOLT 5/16-18 X .625 GR5 |
| 4 | 532 15 53-77 | NUT 5/16-18 |

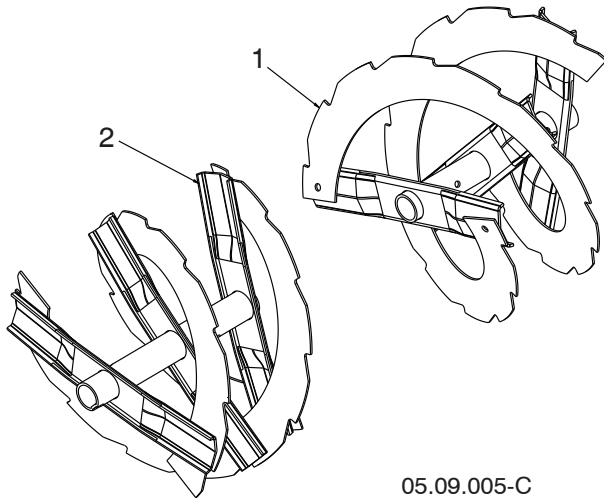

| KEY NO. | PART NO. | DESCRIPTION |
|---------|--------------|----------------------|
| 1 | 532 42 10-72 | AUGER WELD RIB LH 24 |
| 2 | 532 42 10-73 | AUGER WELD RIB RH 24 |

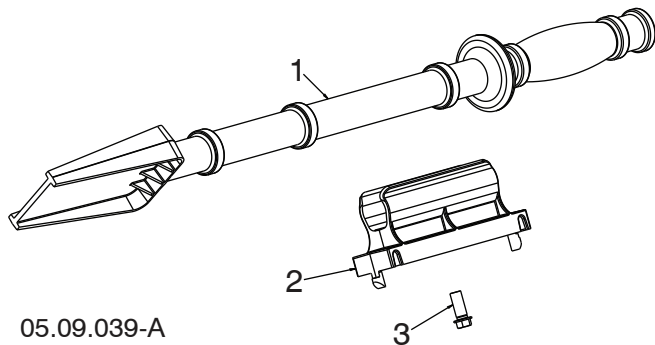

| KEY NO. | PART NO. | DESCRIPTION |
|---------|--------------|------------------------------|
| 1 | 532 19 21-99 | TOOL CLEANOUT |
| 2 | 532 40 54-00 | CLIP CLEANOUT TOOL |
| 3 | 532 19 41-89 | SCREW HEX WASHER 13-16 X 5/8 |

NOTE: All component dimensions given in U.S. inches. 1 inch = 25.4 mm
IMPORTANT: Use only Original Equipment Manufacturer (O.E.M.) replacement parts. Failure to do so could be hazardous, damage your snow thrower and void your warranty.

REPAIR PARTS

AUGER HOUSING / IMPELLER ASSEMBLY

SNOW THROWER - MODEL NO. **ST224** (96193009603), PRODUCT NO. 961 93 00-96

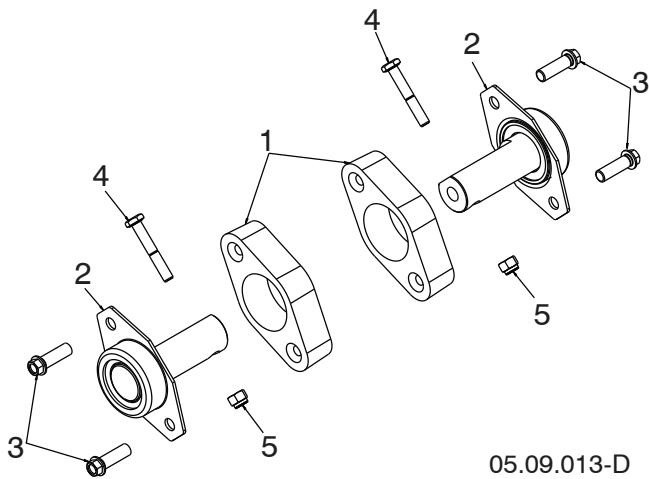

| KEY NO. | PART NO. | DESCRIPTION |
|---------|--------------|----------------------------------|
| 1 | 532 18 81-70 | PLASTIC RETAINER |
| 2 | 532 42 77-62 | AUGER BALL BEARING |
| 3 | 584 29 94-01 | SCREW HI-LO 5/16-14 X 1.00 - BLK |
| 4 | 874 78 04-26 | BOLT SHEAR HEX HD 1/4-20 |
| 5 | 873 80 04-00 | NUT 1/4-20 |

05.09.013-D

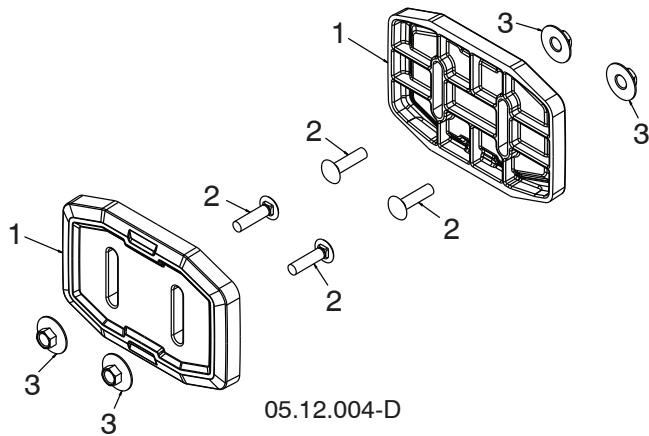

| KEY NO. | PART NO. | DESCRIPTION |
|---------|--------------|------------------------------|
| 1 | 583 83 88-01 | SKID SHOW UHMW |
| 2 | 585 80 29-01 | BOLT CARR BLK 5/16-18 X 1.25 |
| 3 | 585 80 28-01 | NUT HEX 5/16-18 LRG FLG |

05.12.004-D

NOTE: All component dimensions given in U.S. inches. 1 inch = 25.4 mm
IMPORTANT: Use only Original Equipment Manufacturer (O.E.M.) replacement parts.
 Failure to do so could be hazardous, damage your snow thrower and void your warranty.

REPAIR PARTS

CONTROL PANEL / DISCHARGE CHUTE

SNOW THROWER - MODEL NO. **ST224** (96193009603), PRODUCT NO. 961 93 00-96

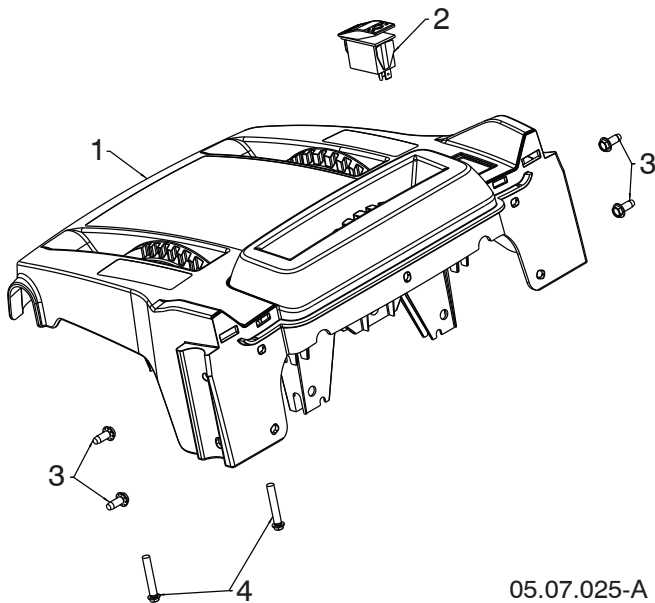

05.07.025-A

| KEY NO. | PART NO. | DESCRIPTION |
|---------|--------------|-------------------------------------|
| 1 | 588 92 59-05 | CONSOLE BASE MULTICONT GRAY-MS498 |
| 2 | 585 80 50-01 | SWITCH GRIP HEATED BLACK |
| 3 | 817 06 04-10 | SCREW TA SEMI GIMLE 1/4-20 X .62 |
| 4 | 581 32 95-01 | SCREW HEX WASHER HI-LO 13-16 X 1.50 |

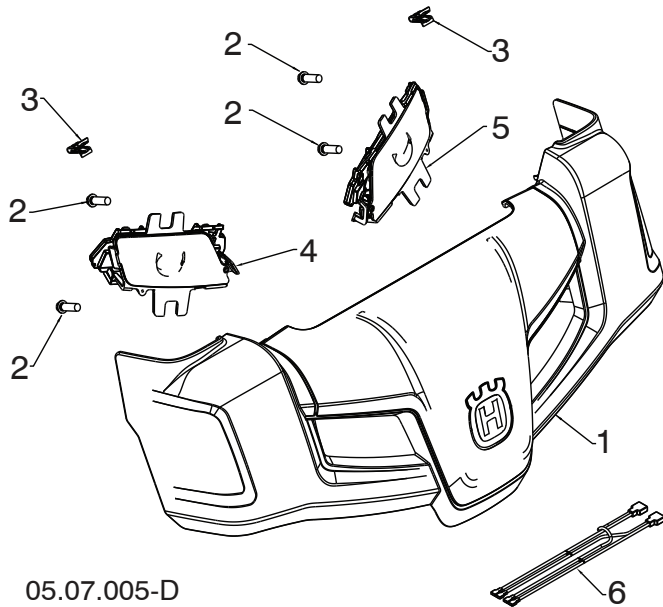

05.07.005-D

| KEY NO. | PART NO. | DESCRIPTION |
|---------|--------------|-----------------------------|
| 1 | 581 12 79-01 | HUSQVARNA CONSOLE COVER ASM |
| 2 | 532 19 41-89 | SCREW HI-LO 13-16 X 5/8 |
| 3 | 581 92 87-01 | CLIP PANEL |
| 4 | 586 72 35-01 | LIGHT ASM LED HUSQ RH |
| 5 | 586 72 36-01 | LIGHT ASM LED HUSQ LH |
| 6 | 585 86 83-01 | WIRE HARNESS LIGHT JUMPER |

NOTE: All component dimensions given in U.S. inches. 1 inch = 25.4 mm
IMPORTANT: Use only Original Equipment Manufacturer (O.E.M.) replacement parts. Failure to do so could be hazardous, damage your snow thrower and void your warranty.

REPAIR PARTS

CONTROL PANEL / DISCHARGE CHUTE

SNOW THROWER - MODEL NO. **ST224** (96193009603), PRODUCT NO. 961 93 00-96

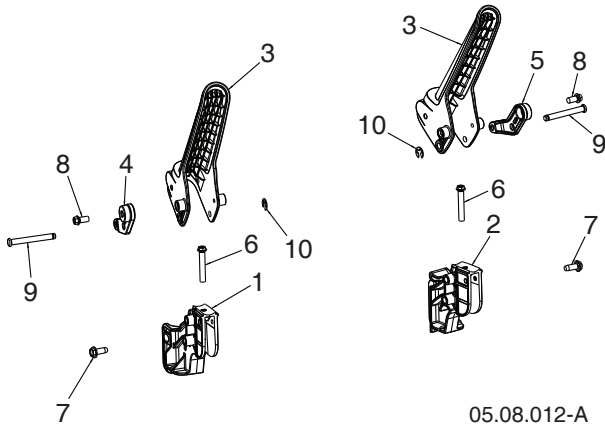

| KEY NO. | PART NO. | DESCRIPTION |
|---------|--------------|---------------------------|
| 1 | 587 73 96-01 | PIVOT, HANDLE LEVER - LHS |
| 2 | 587 73 96-02 | PIVOT, HANDLE LEVER - RHS |
| 3 | 587 46 30-01 | LEVER, CONTROL |
| 4 | 587 73 97-01 | LEVER, CABLE ARM - LHS |
| 5 | 587 73 97-02 | LEVER, CABLE ARM - RHS |
| 6 | 581 32 95-01 | SCREW HI-LO 13-16 X 1.50 |
| 7 | 817 06 04-10 | SCREW 1/4-20 X .625 |
| 8 | 817 41 13-08 | SCREW HI-LW 13-16 X .500 |
| 9 | 588 14 77-01 | PIN, GROOVED |
| 10 | 812 00 00-14 | E-RING |

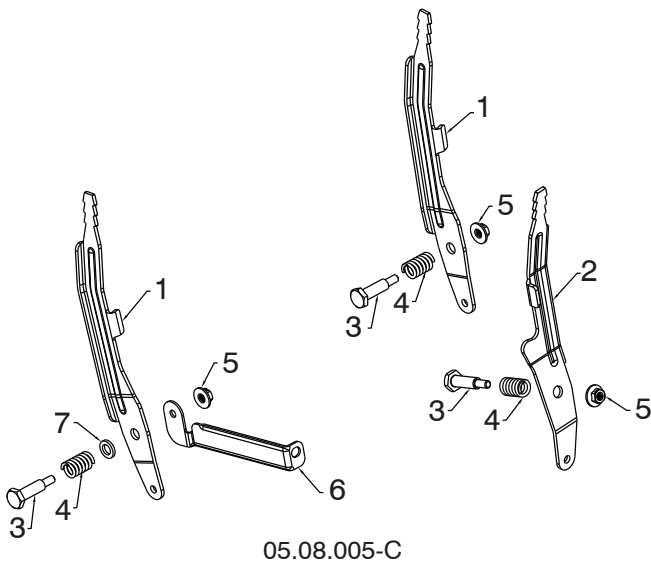

| KEY NO. | PART NO. | DESCRIPTION |
|---------|--------------|-------------------------------------|
| 1 | 581 12 39-02 | LEVER CONTROL SPEED/DEFL |
| 2 | 581 24 16-02 | LEVER CONTROL CHUTE ROT |
| 3 | 581 32 97-01 | BOLT SHOULDER 1/4-20 |
| 4 | 581 32 96-01 | SPRING COMPRESSION |
| 5 | 586 66 89-01 | NUT FL LOCK 1/4-20 |
| 6 | 584 46 84-02 | BRACE SUPPORT SPEED |
| 7 | 587 03 13-01 | WASHER .625 X .375 X .094 NYLON 6/6 |

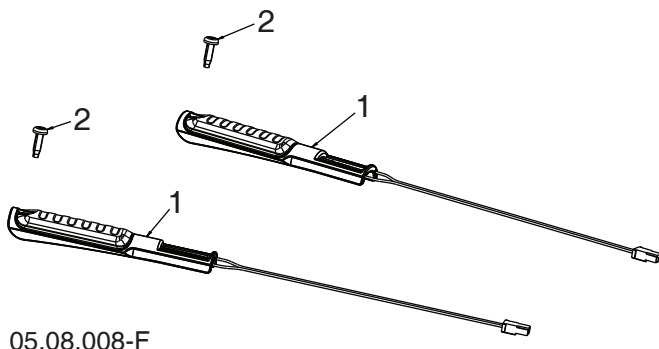

| KEY NO. | PART NO. | DESCRIPTION |
|---------|--------------|--------------------------------|
| 1 | 588 77 59-01 | GRIP HANDLE HEATED |
| 2 | 532 44 22-50 | SCREW PAN HD TORX 1/4-20 X .75 |

NOTE: All component dimensions given in U.S. inches. 1 inch = 25.4 mm
IMPORTANT: Use only Original Equipment Manufacturer (O.E.M.) replacement parts. Failure to do so could be hazardous, damage your snow thrower and void your warranty.

REPAIR PARTS

CONTROL PANEL / DISCHARGE CHUTE

SNOW THROWER - MODEL NO. **ST224** (96193009603), PRODUCT NO. 961 93 00-96

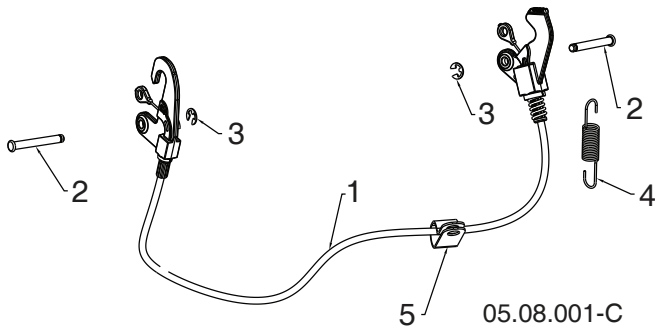

| KEY NO. | PART NO. | DESCRIPTION |
|---------|--------------|------------------|
| 1 | 587 33 25-02 | CABLE INTERLOCK |
| 2 | 532 43 17-62 | PIN GROOVED |
| 3 | 812 00 00-14 | E-RING |
| 4 | 581 15 12-01 | SPRING RETURN |
| 5 | 532 19 79-91 | CLIP CABLE BLACK |

05.08.001-C

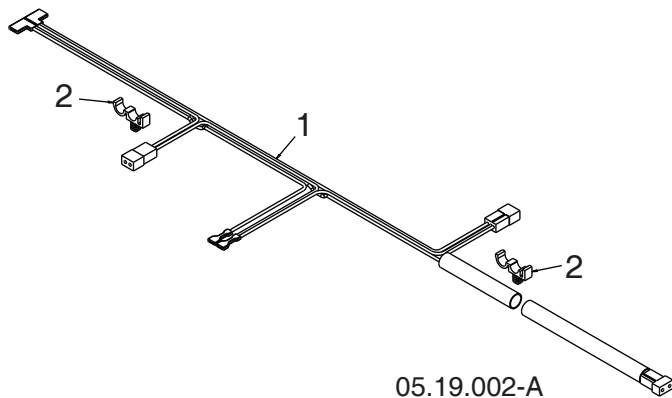

| KEY NO. | PART NO. | DESCRIPTION |
|---------|--------------|-----------------------------|
| 1 | 587 53 57-01 | HARNESS WIRE LIGHTS & GRIPS |
| 2 | 532 14 50-06 | WIRE RETAINER |

05.19.002-A

NOTE: All component dimensions given in U.S. inches. 1 inch = 25.4 mm
IMPORTANT: Use only Original Equipment Manufacturer (O.E.M.) replacement parts. Failure to do so could be hazardous, damage your snow thrower and void your warranty.

REPAIR PARTS

CONTROL PANEL / DISCHARGE CHUTE

SNOW THROWER - MODEL NO. **ST224** (96193009603), PRODUCT NO. 961 93 00-96

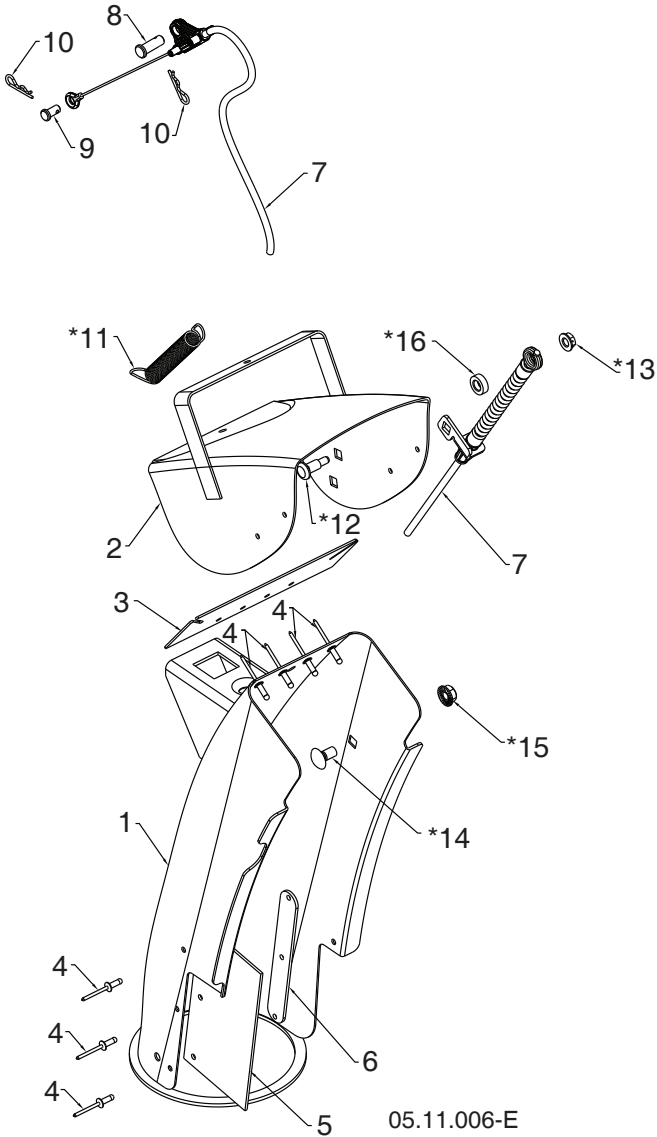

| KEY NO. | PART NO. | DESCRIPTION |
|---------|--------------|---------------------------------|
| 1 | 588 07 78-02 | CHUTE WELDMENT (INCLUDES 1-6) |
| 2 | ----- | DEFLECTOR WELDMENT |
| 3 | ----- | DEFLECTOR SEAL |
| 4 | ----- | POP RIVET |
| 5 | ----- | CHUTE SNOW SHIELD |
| 6 | ----- | SHIELD STRAP RETAINER |
| 7 | 586 96 15-01 | CABLE ASM DEFLECTOR - BOWDEN |
| 8 | 581 32 94-01 | PIN CLEVIS 5/16 X .875 |
| 9 | 585 80 83-01 | PIN CLEVIS 1/4 X .312 |
| 10 | 532 42 33-03 | HAIRPIN RETAINER |
| *11 | 532 18 45-05 | DEFLECTOR SPRING |
| *12 | 501 41 73-01 | CARRIAGE BOLT 1/4-20 X .544 |
| *13 | 585 69 14-01 | NUT 1/4-20 |
| *14 | 585 83 20-01 | CARRIAGE BOLT 3/8-16 X .625 |
| *15 | 873 97 05-00 | NUT 5/16-18 |
| *16 | 501 41 74-01 | WASHER .362 X .625 X .205 NYLON |

NOTE: ALL ITEMS MARKED WITH AN * ARE PROVIDED IN THE BAG OF ITEMS SHIPPED LOOSE WITH PRODUCT.

NOTE: All component dimensions given in U.S. inches. 1 inch = 25.4 mm
IMPORTANT: Use only Original Equipment Manufacturer (O.E.M.) replacement parts. Failure to do so could be hazardous, damage your snow thrower and void your warranty.

REPAIR PARTS

CONTROL PANEL / DISCHARGE CHUTE

SNOW THROWER - MODEL NO. ST224 (96193009603), PRODUCT NO. 961 93 00-96

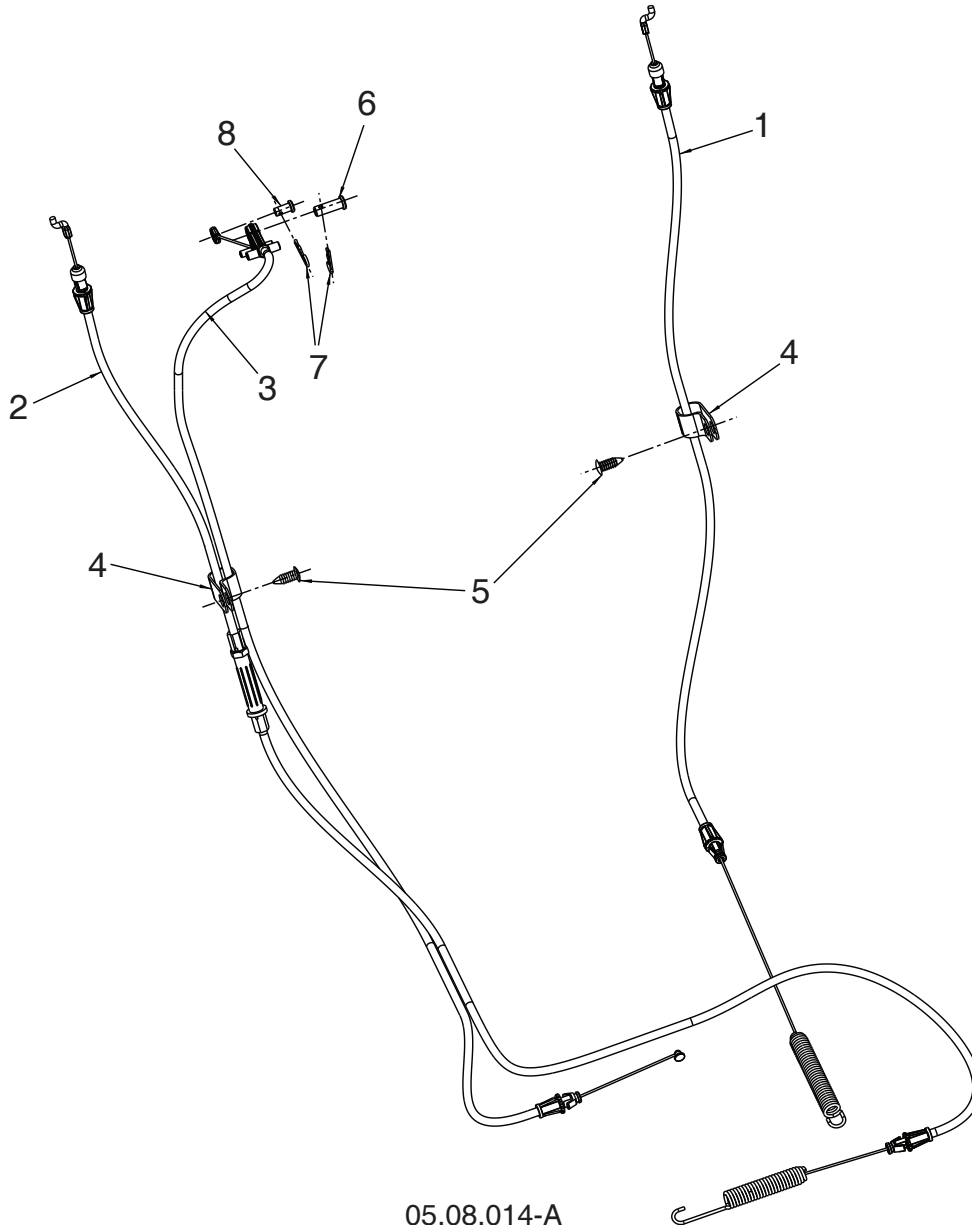

05.08.014-A

| KEY NO. | PART NO. | DESCRIPTION |
|---------|--------------|---------------------|
| 1 | 588 11 37-02 | CABLE CONTROL DRIVE |
| 2 | 588 11 38-02 | CABLE CONTROL AUGER |
| 3 | 588 12 23-01 | CABLE CONTROL SPEED |
| 4 | 532 19 79-91 | CLIP CABLE |
| 5 | 532 42 81-24 | FASTENER PUSH .250 |
| 6 | 581 32 94-01 | PIN CLEVIS 5/16 |
| 7 | 532 42 33-03 | HAIRPIN |
| 8 | 585 80 83-01 | PIN CLEVIS 1/4 |

NOTE: All component dimensions given in U.S. inches. 1 inch = 25.4 mm
IMPORTANT: Use only Original Equipment Manufacturer (O.E.M.) replacement parts. Failure to do so could be hazardous, damage your snow thrower and void your warranty.

REPAIR PARTS

CONTROL PANEL / DISCHARGE CHUTE

SNOW THROWER - MODEL NO. ST224 (96193009603), PRODUCT NO. 961 93 00-96

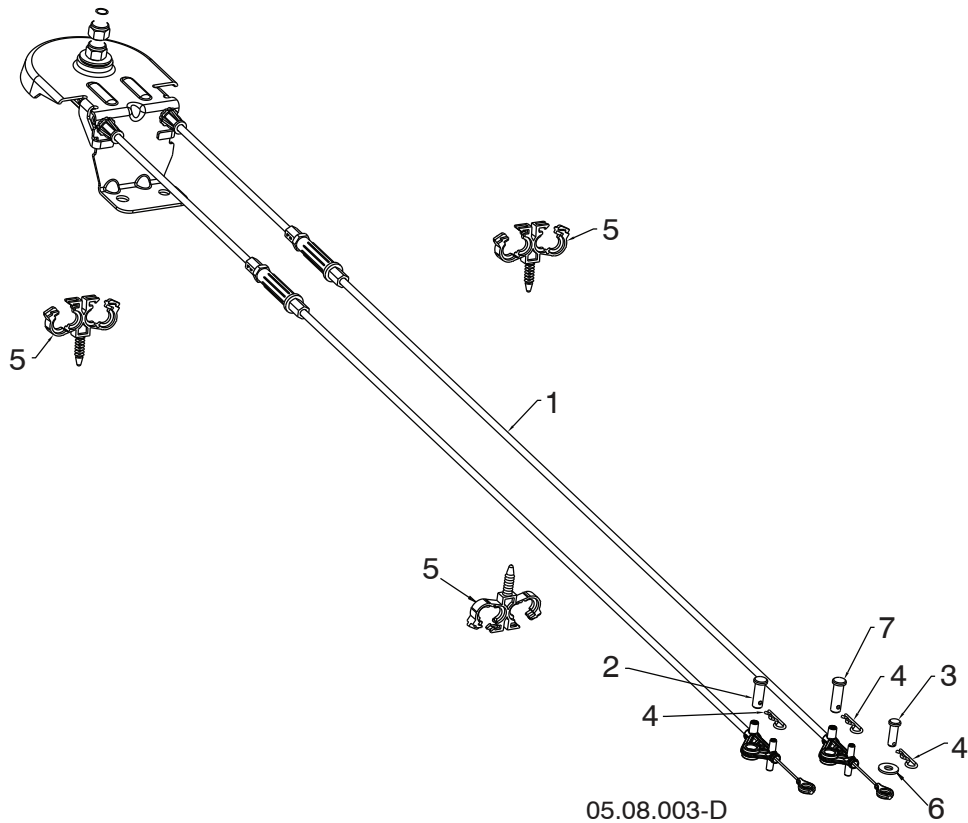

05.08.003-D

| KEY NO. | PART NO. | DESCRIPTION |
|---------|--------------|-----------------------|
| 1 | 581 68 03-01 | CABLE ROTATOR ASM |
| 2 | 581 32 94-01 | PIN CLEVIS 5/16 X 7/8 |
| 3 | 877 10 08-12 | PIN CLEVIS 1/4 X 3/4 |
| 4 | 532 42 33-03 | HAIRPIN SOFT ZINC |
| 5 | 584 65 22-01 | CLIP CONDUIT DOUBLE |
| 6 | 586 68 21-01 | WASHER |
| 7 | 587 13 08-01 | PIN CLEVIS 5/16 X 1 |

NOTE: All component dimensions given in U.S. inches. 1 inch = 25.4 mm
IMPORTANT: Use only Original Equipment Manufacturer (O.E.M.) replacement parts. Failure to do so could be hazardous, damage your snow thrower and void your warranty.

REPAIR PARTS

HANDLES

SNOW THROWER - MODEL NO. **ST224** (96193009603), PRODUCT NO. 961 93 00-96

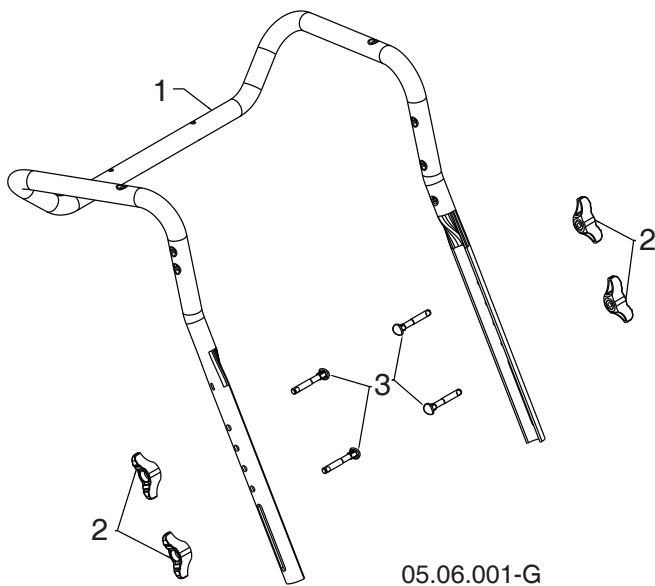

| KEY NO. | PART NO. | DESCRIPTION |
|---------|--------------|---|
| 1 | 588 16 08-03 | UPPER HANDLE |
| 2 | 532 19 19-38 | HANDLE KNOB STD BLACK |
| 3 | 588 05 99-01 | SCREW 5/16-18 X 2.25 CONCAVE HEAD WITH PATCH |

05.06.001-G

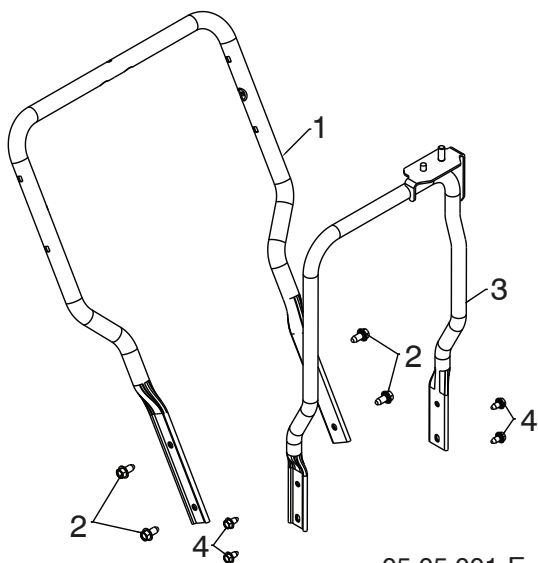

| KEY NO. | PART NO. | DESCRIPTION |
|---------|--------------|-----------------------------------|
| 1 | 588 67 21-03 | LOWER HANDLE |
| 2 | 817 00 06-12 | SCREW HEX WASH HD 3/8-16 X .75 |
| 3 | 581 62 20-02 | CHUTE ROTATOR SUPPORT ASM |
| 4 | 817 00 05-10 | BOLT HEX 5/16-18 |

05.05.001-E

NOTE: All component dimensions given in U.S. inches. 1 inch = 25.4 mm
IMPORTANT: Use only Original Equipment Manufacturer (O.E.M.) replacement parts.
 Failure to do so could be hazardous, damage your snow thrower and void your warranty.

REPAIR PARTS

DRIVE

SNOW THROWER - MODEL NO. ST224 (96193009603), PRODUCT NO. 961 93 00-96

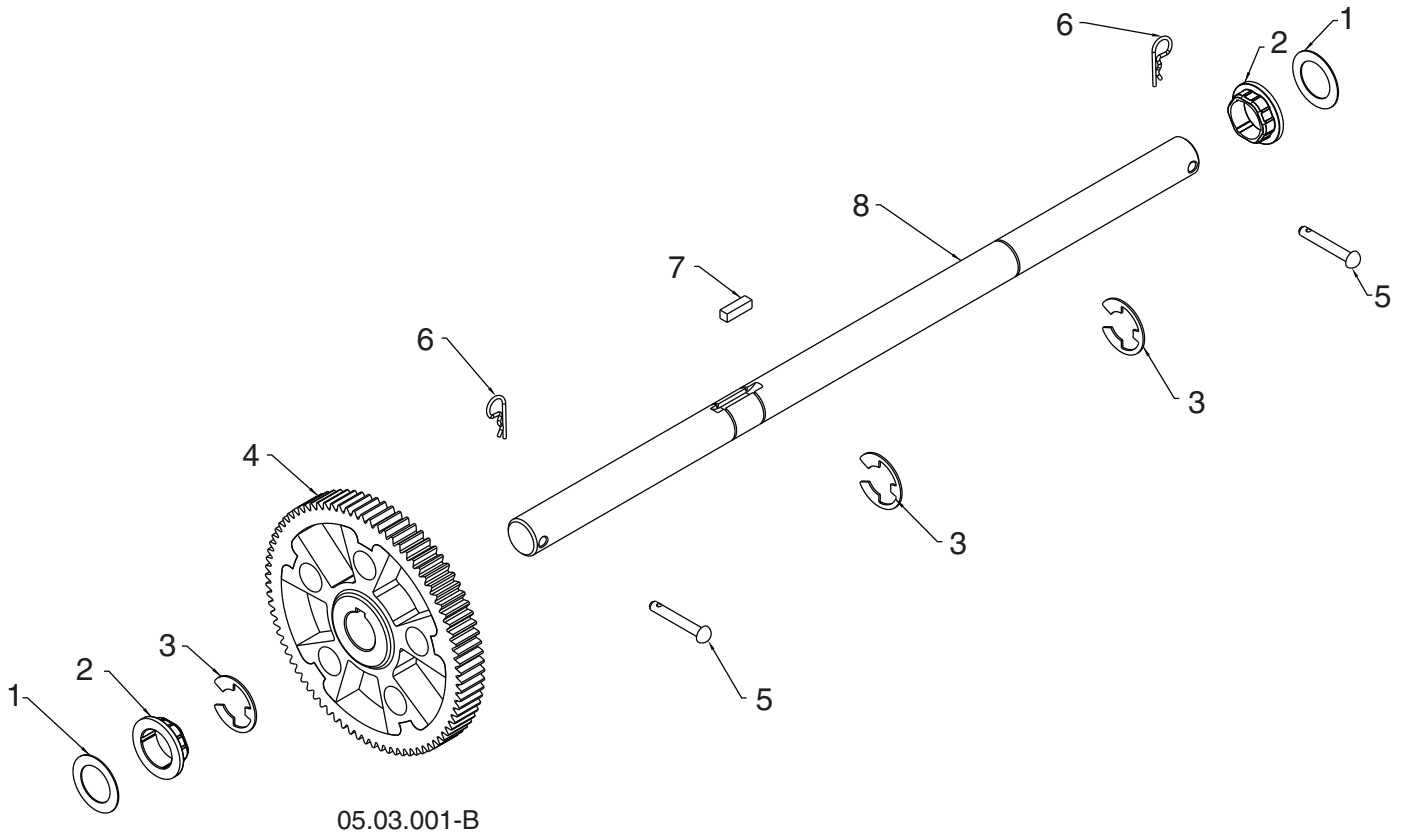

| KEY NO. | PART NO. | DESCRIPTION |
|---------|--------------|-----------------------------|
| 1 | 532 44 49-49 | WASHER 1.00 |
| 2 | 587 97 89-01 | HEX BUSHING 1 SHAFT |
| 3 | 812 00 00-53 | RETAINING RING |
| 4 | 588 51 87-02 | GEAR 80T DRIVEN |
| 5 | 532 17 12-71 | RIVET RD HD DRILLED 1/4 DIA |
| 6 | 532 12 47-88 | RETAINER SPRING |
| 7 | 532 18 92-82 | SQUARE KEY 1/4 X .875 |
| 8 | 581 12 20-01 | AXLE SHAFT |

NOTE: All component dimensions given in U.S. inches. 1 inch = 25.4 mm
IMPORTANT: Use only Original Equipment Manufacturer (O.E.M.) replacement parts. Failure to do so could be hazardous, damage your snow thrower and void your warranty.

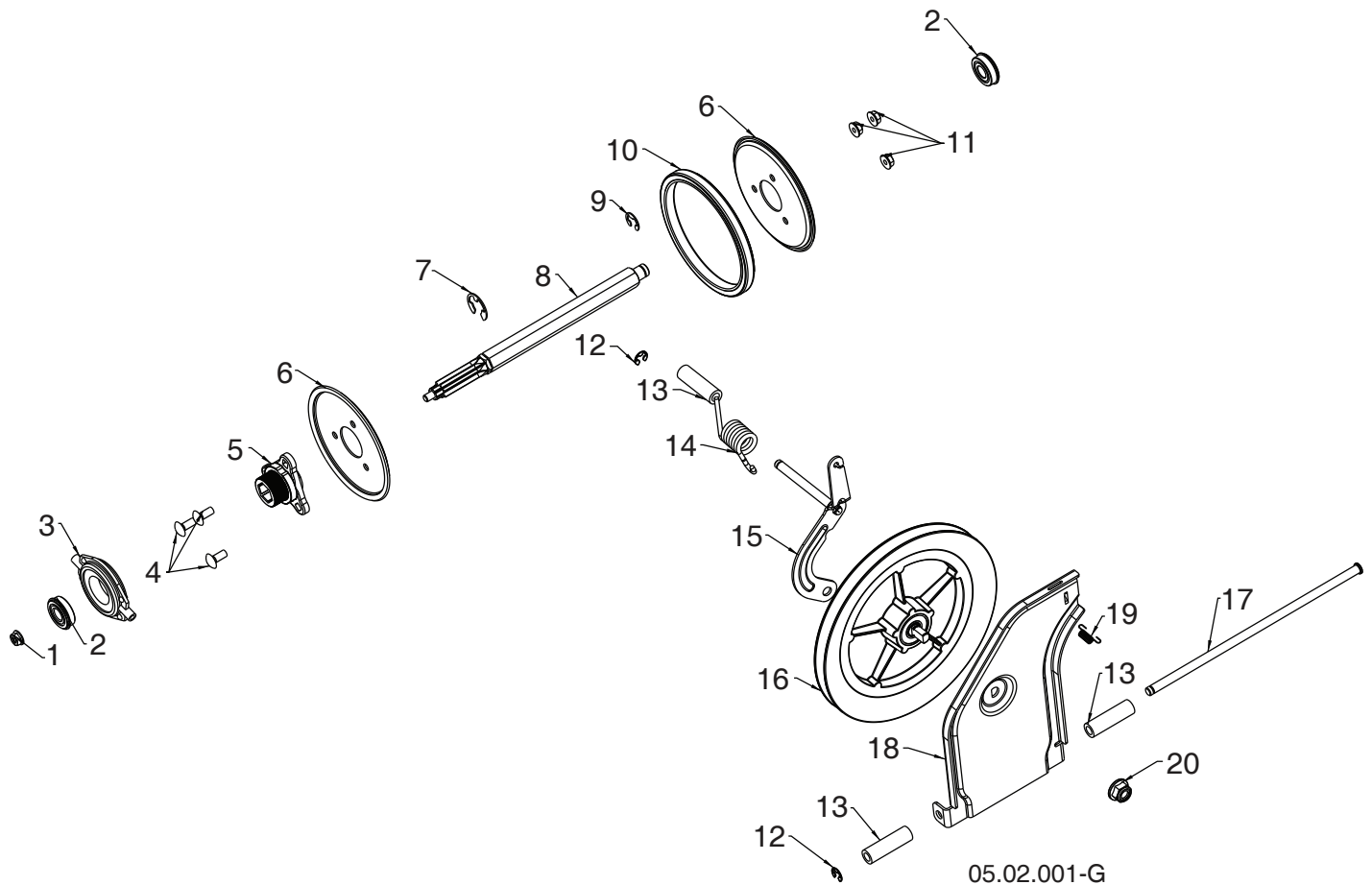

NOTE: All component dimensions given in U.S. inches. 1 inch = 25.4 mm
IMPORTANT: Use only Original Equipment Manufacturer (O.E.M.) replacement parts. Failure to do so could be hazardous, damage your snow thrower and void your warranty.

REPAIR PARTS**DRIVE****SNOW THROWER - MODEL NO. ST224 (96193009603), PRODUCT NO. 961 93 00-96**

| KEY NO. | PART NO. | DESCRIPTION |
|----------------|-----------------|----------------------------------|
| 1 | 585 69 15-01 | NUT HEX FLANGE LK 5/16-18 |
| 2 | 580 75 62-01 | BEARING 9/16 I.D. 1622-2RSNR |
| 3 | 532 17 53-44 | TRUNNION BEARING ASM |
| 4 | 872 11 05-06 | BOLT CARRIAGE 5/16-18 X .75 GR 5 |
| 5 | 581 09 09-01 | HUB RUBBER WHEEL |
| 6 | 581 09 10-02 | RUBBER WHEEL PLATE |
| 7 | 812 00 00-22 | E-RING |
| 8 | 581 12 19-01 | SHAFT 7 TOOTH REDUCTION |
| 9 | 580 75 61-02 | RETAINING RING 1622-2RSNR |
| 10 | 581 09 11-01 | RUBBER WHEEL RING |
| 11 | 532 75 11-53 | NUT HEX FLANGE LK 5/16-18 |
| 12 | 812 00 00-07 | E-RING RETAINER 375 |
| 13 | 581 73 27-01 | DRIVE SPACER |
| 14 | 581 31 53-01 | DRIVE TORSION SPRING |
| 15 | 587 19 34-03 | YOKE BRACKET ASSEMBLY |
| 16 | 581 32 84-01 | FRICTION PULLEY DISC COMBO |
| 17 | 581 12 30-01 | ROD TIP PLATE |
| 18 | 587 70 34-02 | FRICTION SWING PLATE PULL |
| 19 | 532 19 38-85 | LATCH SPRING |
| 20 | 521 99 11-01 | NUT HEX FLANGE LK 1/2-13 |

NOTE: All component dimensions given in U.S. inches. 1 inch = 25.4 mm

IMPORTANT: Use only Original Equipment Manufacturer (O.E.M.) replacement parts. Failure to do so could be hazardous, damage your snow thrower and void your warranty.

REPAIR PARTS

CHASSIS / ENGINE / PULLEYS

SNOW THROWER - MODEL NO. **ST224** (96193009603), PRODUCT NO. 961 93 00-96

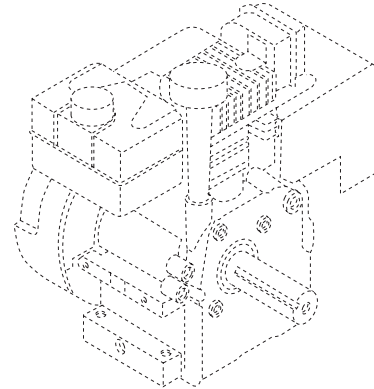
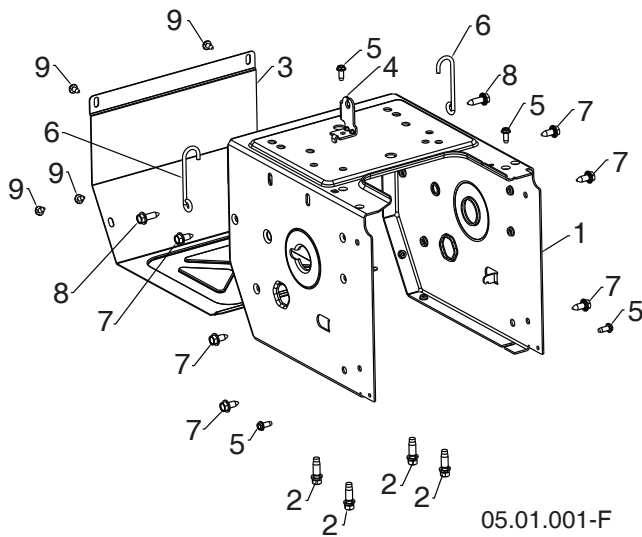

| KEY NO. | PART NO. | DESCRIPTION |
|---------|--------------|-------------------------------------|
| -- | 580 42 60-03 | COMPLETE LCT ENGINE PW2HK18650178E |
| 1 | 580 83 94-05 | FRAME |
| 2 | 532 15 04-06 | ENGINE BOLT 3/8-16 X 1.280 DOGPOINT |
| 3 | 580 83 95-05 | FRAME COVER |
| 4 | 501 06 04-03 | SHIFTER BRACKET |
| 5 | 817 06 04-10 | SCREW HEX WASHER 1/4-20 X .625 |
| 6 | 588 95 45-01 | WIREFORM SUPPORT CABLE |
| 7 | 532 42 88-67 | BOLT HEXHD WASHER 5/16-18 X .750 |
| 8 | 585 21 75-01 | BOLT HEXHD WASHER 5/16-18 X 1.000 |
| 9 | 817 06 04-08 | SCREW HEX WASHER 1/4-20 X .500 |

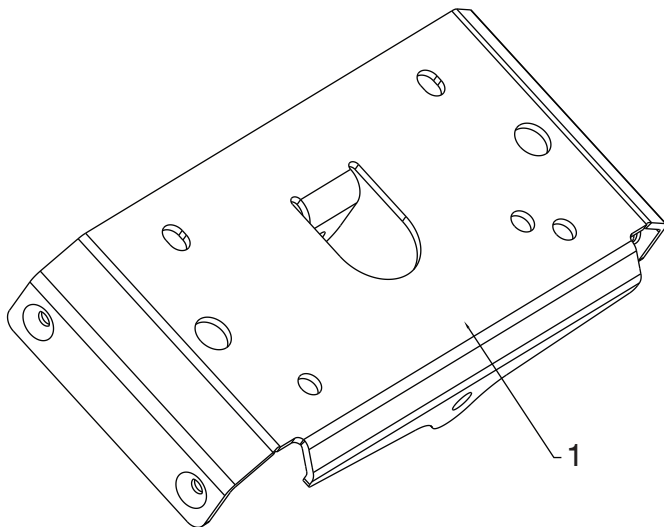

| KEY NO. | PART NO. | DESCRIPTION |
|---------|--------------|----------------------|
| 1 | 583 94 05-02 | SMALL MOUNTING PLATE |

NOTE: All component dimensions given in U.S. inches. 1 inch = 25.4 mm
IMPORTANT: Use only Original Equipment Manufacturer (O.E.M.) replacement parts. Failure to do so could be hazardous, damage your snow thrower and void your warranty.

REPAIR PARTS

CHASSIS / ENGINE / PULLEYS

SNOW THROWER - MODEL NO. **ST224** (96193009603), PRODUCT NO. 961 93 00-96

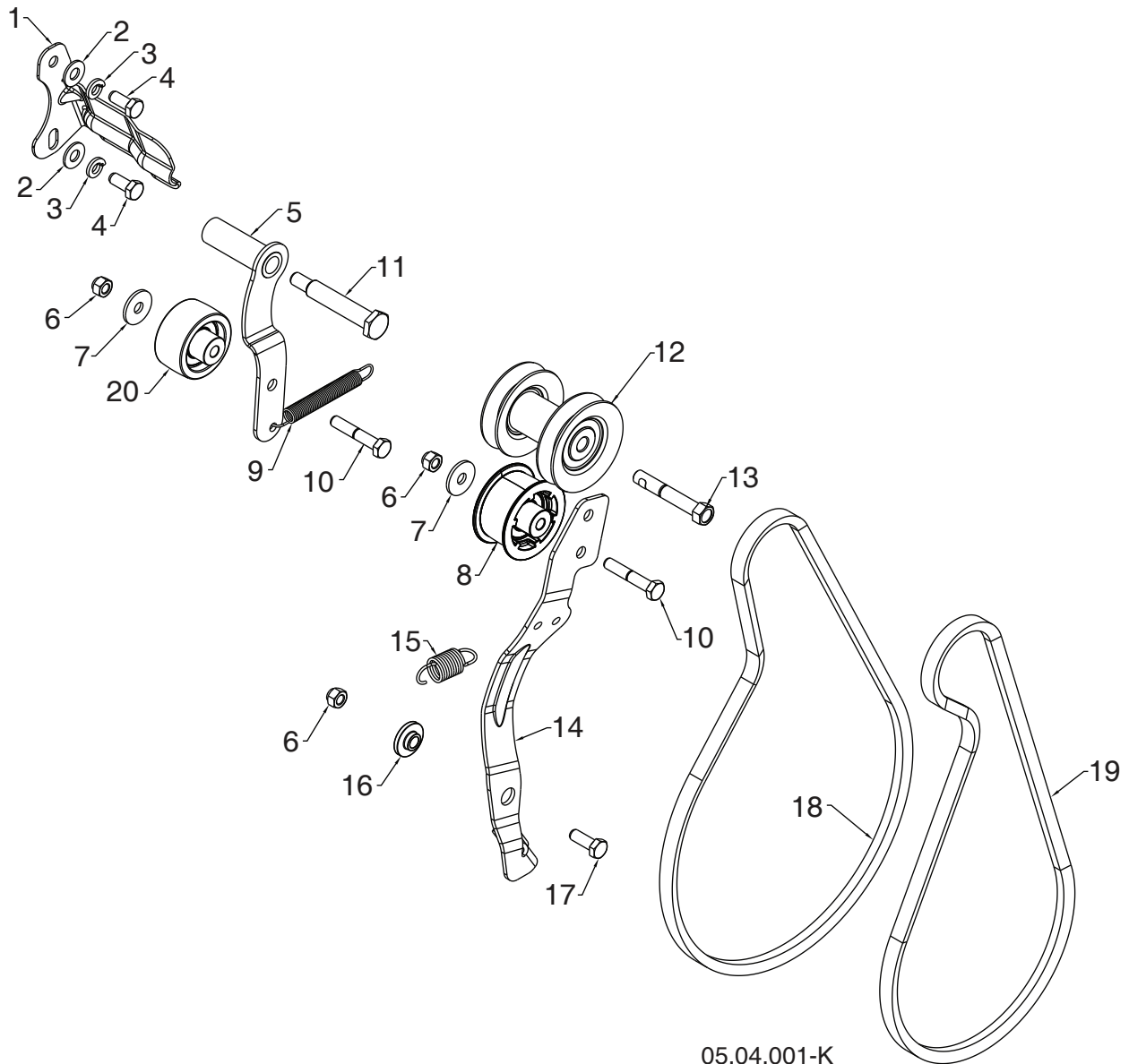

05.04.001-K

| KEY NO. | PART NO. | DESCRIPTION | KEY NO. | PART NO. | DESCRIPTION |
|---------|--------------|-----------------------------------|---------|--------------|--------------------------------------|
| 1 | 588 49 28-02 | BELT KEEPER BRACKET | 11 | 581 41 38-01 | SHOULDER BOLT 5/16-24 X 2.15 |
| 2 | 819 11 12-16 | WASHER 11/32 X 3/4 X 16 GA | 12 | 587 89 37-03 | PULLEY ASM ENGINE |
| 3 | 810 04 05-00 | LOCKWASHER 5/16 SPLIT HVY | 13 | 582 38 84-01 | BOLT HEXHD 3/8-24 X 2.375 |
| 4 | 874 61 05-12 | CAPSCREW HEXHD 5/16-24 X .75 GR 5 | 14 | 580 83 11-06 | ARM IDLER |
| 5 | 581 33 82-03 | IDLER ARM DRIVE WELDMENT | 15 | 587 03 12-01 | RETURN SPRING IDLER ARM |
| 6 | 873 80 05-00 | NUT NYLOCK 5/16-18 | 16 | 587 34 37-01 | BUSHING IDLER PIVOT |
| 7 | 532 05 92-89 | WASHER FLAT .328 X 1.00 X .097 | 17 | 874 76 05-14 | BOLT HEXHD 5/16-18 X .875 |
| 8 | 581 14 14-01 | IDLER PULLEY 2.0 W/SPACER | 18 | 584 21 61-02 | DRIVE BELT 4L X 38.2 |
| 9 | 580 75 30-01 | RETURN SPRING IDLER ARM DRIVE | 19 | 501 81 82-01 | IMPELLER BELT |
| 10 | 874 76 05-28 | BOLT HEXHD 5/16-18 X 1.75 | 20 | 586 88 02-01 | IDLER PULLEY 2.0 FLANGELESS W/SPACER |

NOTE: All component dimensions given in U.S. inches. 1 inch = 25.4 mm
IMPORTANT: Use only Original Equipment Manufacturer (O.E.M.) replacement parts. Failure to do so could be hazardous, damage your snow thrower and void your warranty.

REPAIR PARTS

CHASSIS / ENGINE / PULLEYS

SNOW THROWER - MODEL NO. **ST224** (96193009603), PRODUCT NO. 961 93 00-96

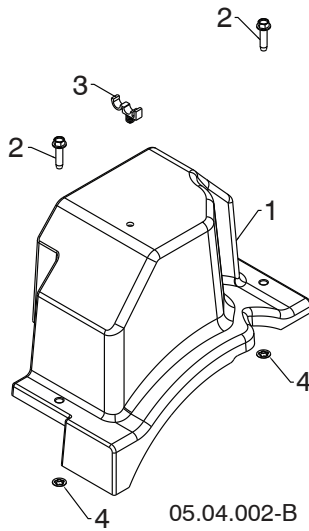

| KEY NO. | PART NO. | DESCRIPTION |
|---------|--------------|--|
| 1 | 587 10 54-01 | BELT COVER BLACK ASSEMBLY (INCLUDES 2 & 4) |
| 2 | ----- | BOLT HEX WSH THDRL 1/4-20 X 1 |
| 3 | 532 14 50-06 | CABLE GUIDE |
| 4 | ----- | PALNUT 1/4 IN |

NOTE: All component dimensions given in U.S. inches. 1 inch = 25.4 mm
IMPORTANT: Use only Original Equipment Manufacturer (O.E.M.) replacement parts. Failure to do so could be hazardous, damage your snow thrower and void your warranty.

REPAIR PARTS

WHEELS

SNOW THROWER - MODEL NO. **ST224** (96193009603), PRODUCT NO. 961 93 00-96

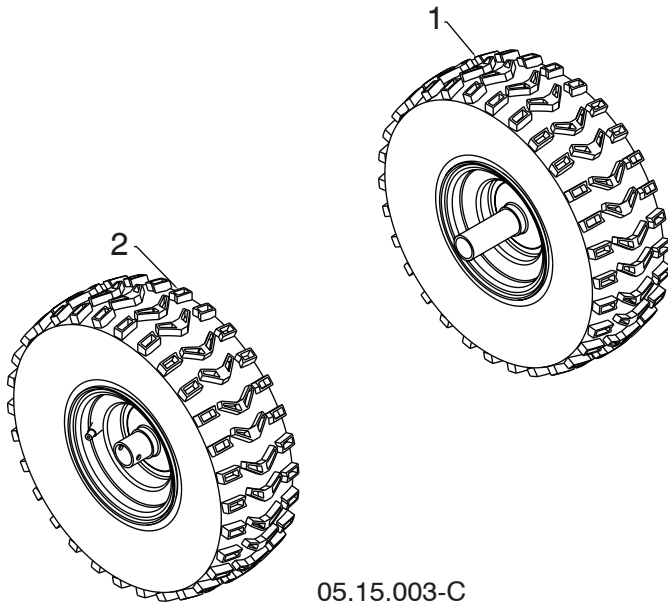

| KEY NO. | PART NO. | DESCRIPTION |
|---------|--------------|-----------------------------------|
| 1 | 586 71 04-01 | WHEEL 15X5.00 NPS LH 1.00 K478 |
| 2 | 586 71 03-01 | WHEEL 15X5.00 NPS RH 1.00 K478 |

NOTE: All component dimensions given in U.S. inches. 1 inch = 25.4 mm
IMPORTANT: Use only Original Equipment Manufacturer (O.E.M.) replacement parts.
Failure to do so could be hazardous, damage your snow thrower and void your warranty.

REPAIR PARTS

BAG OF PARTS

SNOW THROWER - MODEL NO. **ST224** (96193009603), PRODUCT NO. 961 93 00-96

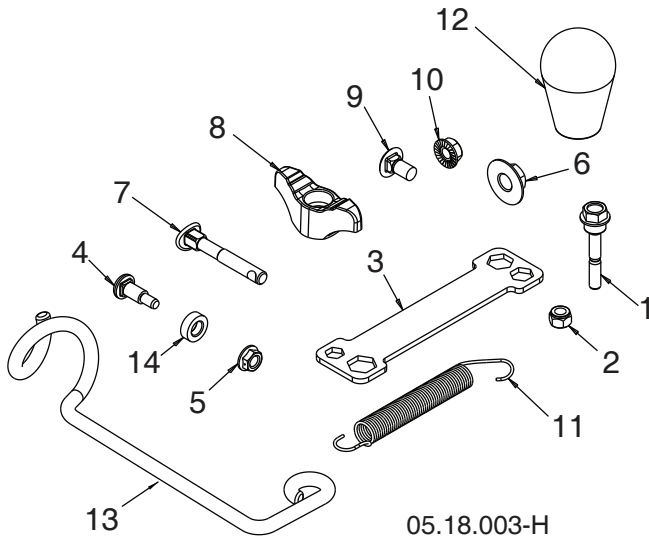

| KEY NO. | PART NO. | DESCRIPTION |
|---------|--------------|------------------------------|
| 1 | 588 07 75-01 | BOLT 1/4-20 X 1.81 |
| 2 | 873 80 04-00 | NUT NYLOCK 1/4-20 |
| 3 | 532 42 91-12 | WRENCH |
| 4 | 501 41 73-01 | BOLT SHOULDER |
| 5 | 585 69 1401 | NUT HEX FL 1/4-20 CTR |
| 6 | 585 69 10-01 | NUT NYLOCK 3/8-16 |
| 7 | 588 05 99-01 | BOLT 5/16-18 X 2.25 CONCAVE |
| 8 | 532 19 19-38 | KNOB 5/16-18 TWO-WING |
| 9 | 585 83 20-01 | BOLT 5/16-18 X .625 |
| 10 | 873 97 05-00 | NUT SERR FL LOCK 5/16-18 |
| 11 | 532 18 45-05 | SPRING DEFLECT CHUTE |
| 12 | 581 69 75-01 | KNOB SOFT TOUCH SLOTTED |
| 13 | 581 89 73-01 | SUPPORT ROTATION CABLE |
| 14 | 501 41 74-01 | WASHER NYLON |
| NI | 588 07 76-03 | KIT REPLACEMENT BAG OF PARTS |

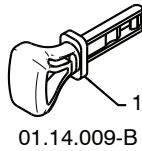

| KEY NO. | PART NO. | DESCRIPTION |
|---------|--------------|-------------------------|
| 1 | 532 44 30-59 | SAFETY IGNITION KEY KIT |

NOTE: All component dimensions given in U.S. inches. 1 inch = 25.4 mm
IMPORTANT: Use only Original Equipment Manufacturer (O.E.M.) replacement parts.
 Failure to do so could be hazardous, damage your snow thrower and void your warranty.



1



3



2



4

| KEY NO. | PART NO. | DESCRIPTION |
|---------|--------------|--------------------|
| 1 | 532 18 40-45 | DECAL AUGER |
| 2 | 532 19 96-82 | DECAL CHUTE |
| 3 | 532 19 96-83 | DECAL AUGER SAFETY |
| 4 | 532 18 40-28 | DECAL BELT GUIDE |

05.16.001-A

NOTE: All component dimensions given in U.S. inches. 1 inch = 25.4 mm
IMPORTANT: Use only Original Equipment Manufacturer (O.E.M.) replacement parts. Failure to do so could be hazardous, damage your snow thrower and void your warranty.

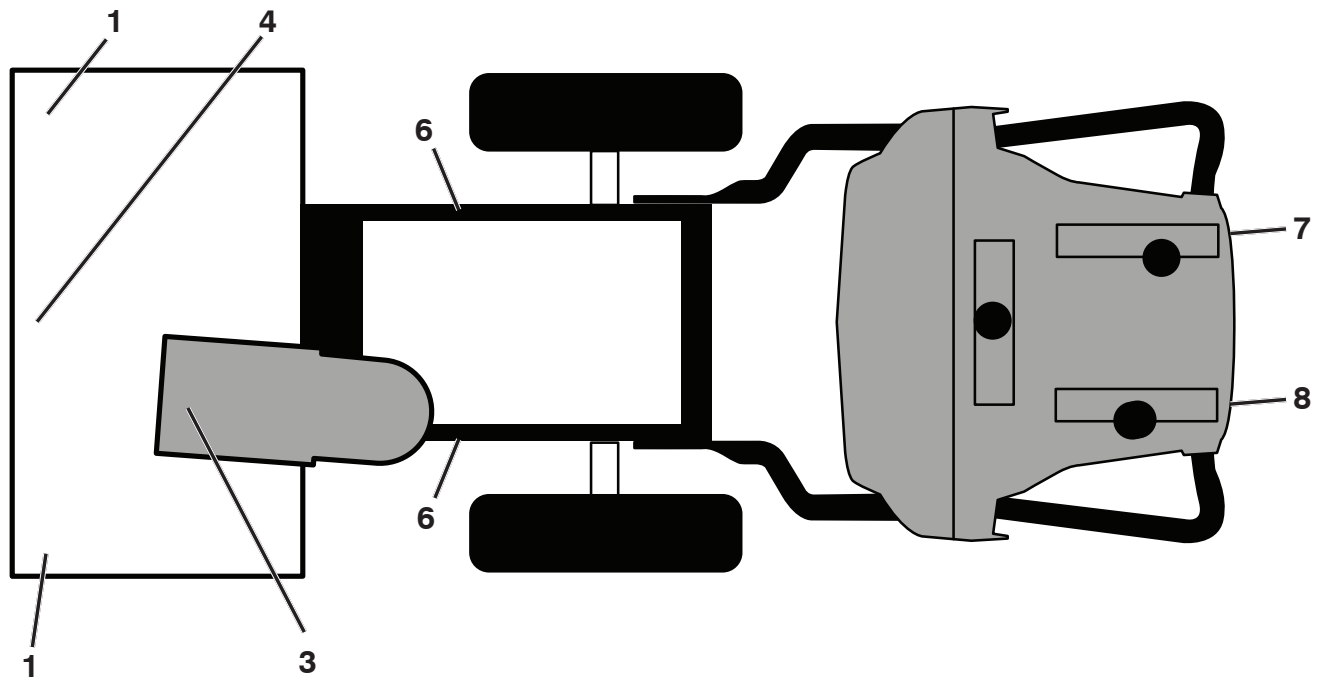

| KEY NO. | PART NO. | DESCRIPTION |
|---------|--------------|----------------------------|
| 1 | 532 19 96-83 | DECAL, DANGER |
| 3 | 532 19 96-82 | DECAL, DANGER, DEFLECTOR |
| 4 | 532 18 40-45 | DECAL, DANGER |
| 6 | 532 18 40-28 | DECAL, INSTRUCTION |
| 7 | 587 65 98-01 | DECAL |
| 8 | 587 65 97-01 | DECAL |
| -- | 115 73 40-27 | OPERATOR'S MANUAL, ENGLISH |
| -- | 115 73 40-31 | OPERATOR'S MANUAL, FRENCH |
| -- | 115 73 40-46 | OPERATOR'S MANUAL, SPANISH |

NOTE: All component dimensions given in U.S. inches. 1 inch = 25.4 mm
IMPORTANT: Use only Original Equipment Manufacturer (O.E.M.) replacement parts. Failure to do so could be hazardous, damage your snow thrower and void your warranty.

ENGINE, LCT

COMPLETE ENGINE-580426003

GEN II 136/179/208/254cc Snow Engines

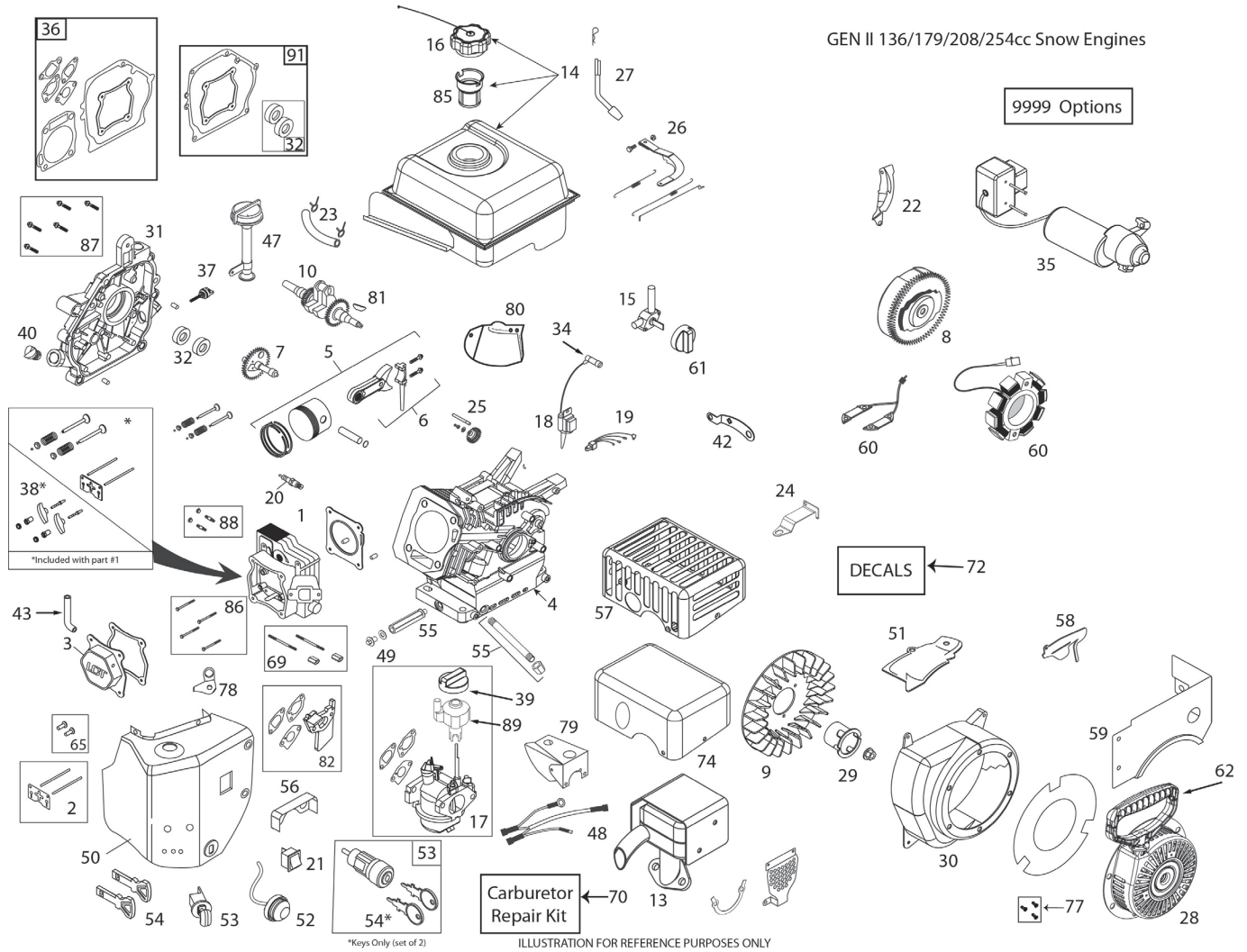

*Keys Only (set of 2)

ILLUSTRATION FOR REFERENCE PURPOSES ONLY

| KEY NO. | PART NO. | DESCRIPTION | KEY NO. | PART NO. | DESCRIPTION |
|---------|--------------|--|---------|--------------|---|
| 1 | 532 42 05-78 | CYLINDER HEAD ASSEMBLY - 208CC (INCL. GASKET) | 15 | 532 42 92-34 | FUEL TANK ON/OFF VALVE - GEN II SNOW |
| 2 | 532 42 05-79 | PUSH ROD & PLATE KIT(208CC) (INCL. VALVE COVER GSKT) | 16 | 532 42 49-42 | FUEL TANK CAP - BLACK CLICK STYLE (VENTED) |
| 3 | 532 42 05-80 | VALVE COVER (208CC) (INCL. GASKET) | 17 | 587 14 79-01 | CARB W/IDLE SPEED CONTROL (L10-1D) 208CCW/GASKET |
| 4 | 587 14 75-01 | CYLINDER - 208CC GEN LL SNOW | 18 | 532 44 38-94 | IGNITION COIL (CDI) (208/254CC)(STANDARD) |
| 5 | 532 42 05-82 | PISTON & ROD ASSEMBLY (208CC) | 19 | N/A | N/A |
| 6 | 532 42 05-83 | CONNECTING ROD ASSEMBLY (208CC) | 20 | 532 42 49-39 | SPARK PLUG |
| 7 | 532 42 05-84 | CAMSHAFT - MCR (208CC) | 21 | 532 42 49-57 | ON/OFF SWITCH - ROCKER |
| 8 | 532 44 3892 | FLYWHEEL - ELECTRIC START (6-CHARGING MAGNETS) (208CC) | 22 | 532 42 49-75 | SHIELD - FLYWHEEL - ELECTRIC START - SNOW |
| 9 | 532 42 05-86 | COOLLNG FAN - FLYWHEEL (PLASTIC - 208CC) | 23 | 532 43 21-44 | FUEL HOSE KIT (1/4" ID X 318MM - SS SNOW) |
| 10 | 532 44 66-42 | CRANKSHAFT (#18 KEYED 208CC SNOW) | 24 | 532 42 92-59 | SPEED CONTROL BRACKET (FIXED) |
| 13 | 587 14 77-01 | MUFFLER ASSEMBLY-GEN LL SNOW | 25 | 532 42 96-46 | GOVERNOR GEAR ASSEMBLY (136/208CC) |
| 14 | 532 43 65-64 | FUEL TANK (208CC-SNOW) (2.7L BLACK W/PLASTIC CAP - GEN II) | 26 | 581 76 87-01 | GOVERNOR ARM & LINK KIT (208CC SNOW - 3600 FIXED RPM) |
| | | | 27 | 532 42 06-02 | GOVERNOR ARM PADDLE |

ENGINE, LCT**COMPLETE ENGINE-580426003**

| KEY NO. | PART NO. | DESCRIPTION | KEY NO. | PART NO. | DESCRIPTION |
|---------|--------------|--|---------|--------------|---|
| 28 | 532 43 69-67 | RECOIL STARTER (ROUND STYLE-BLACK) 136/208CC GEN II SNOW | 55 | 587 15 44-01 | OIL DRAIN TUBE-SNOW AND CAP (136/208CC) |
| 29 | 532 43 69-68 | STARTER CUP (USE WITH ROUND STYLE STARTER) (208CC SNOW) | 56 | 532 42 92-60 | CARBURETOR VAPOR SHIELD - 208CC SNOW |
| 30 | 581 19 20-01 | BLOWER HOUSING - BLACK ELECTRIC STARTW/INTEGRATED BAFFLE (SN >1265H0604537) (208CC SNOW) | 57 | 532 43 66-72 | CE COMPLIANT MUFFLER SHIELD (208CC) |
| 31 | 581 00 73-01 | CRANKCASE COVER ASSY (PRESS-IN TYPE HOFT)(INCL. GASKET) (SN >1265H0519257) | 58 | 532 42 49-60 | SHIELD - GOVERNOR LINKAGE - 208CC SNOW |
| 32 | 532 42 95-99 | OIL SEAL KIT (2 PCS FOR 3/4-INCH CRANKSHAFT) | 59 | 532 43 65-62 | FUEL TANK SKIRT (208CC SNOW) |
| 34 | 532 43 69-66 | SPARK PLUG BOOT - WITH METAL SHIELD (SNOW) | 60 | 532 44 38-93 | CHARGING COIL (60-WATT AC) (208/254CC) |
| 35 | 532 43 64-66 | 120V ELECTRIC STARTER (208/254CC GEN LL) (MOUNTING BOLTS ON SIDE OF BLOCK) | 61 | 532 43 27-52 | FUEL CONTROL KNOB (GEN II SNOW - RED) |
| 36 | 532 42 96-01 | ENGINE GASKET KIT (208CC) | 62 | 532 44 38-99 | STARTER GRIP-SNOW |
| 37 | 532 42 09-61 | SMALL BLACK OIL DIPSTICK (PLASTIC) | 65 | 581 37 28-01 | TAPPET KIT (208/254CC) (SET OF 2) |
| 38 | 532 42 96-91 | ROCKER ARM KIT (208CC) (INCL. GASKET) | 69 | 532 42 49-51 | CARBURETOR STUDS & COUPLING KIT-SNOW |
| 39 | 532 42 92-24 | CHOKE CONTROL KNOB (GEN II RED) | 70 | 580 35 36-01 | CARBURETOR REPAIR KIT (136/208/254CC) |
| 40 | 532 42 95-98 | NON-REMOVABLE PLASTIC PLUG (136/208/254CC) | 72 | 532 43 56-47 | STORMFORCE LABEL KIT-208CC SNOW |
| 42 | N/A | N/A | 74 | 587 14 82-01 | MUFFLER HEAT SHIELD COVER (136/208/254) |
| 43 | 580 35 34-01 | BREATHERTUBE (136/208/254CC) | 77 | 532 43 26-88 | RECOIL BOLT KIT (INCL. (3) MTG BOLTS) |
| 47 | 581 00 72-01 | HIGH OIL-FILL TUBE/DIPSTICK (PRESS-IN TYPE) (SN >1265H0519257) | 78 | 581 45 93-01 | BREATHER TUBE BRACKET |
| 48 | 532 42 92-62 | WIRE HARNESS (208CC SNOW) | 79 | 585 77 37-01 | CARBURETOR COVER (136/208/254CC SNOW) |
| 49 | 532 43 54-95 | OIL DRAIN PLUG W/WASHER (136/208/254CC) | 80 | N/A | N/A |
| 50 | 532 43 65-61 | HEATER BOX KIT (GEN LL 208CC SNOW) | 81 | 585 29 72-01 | WOODRUFF FLYWHEEL KEYS (5-PACK) (5X6X18MM) |
| 51 | 532 43 71-19 | SHIELD - CYLLNDER (208CC SNOW) | 82 | 585 02 05-03 | CARBURETOR SPACER (208/254CC) |
| 52 | 532 42 49-49 | PRIMER BULB WITH HOSE-SNOW | 85 | 586 32 56-01 | FUEL TANK STRAINER |
| 53 | 532 42 49-54 | KEY SWITCH - SAFETY (PUSH/PULL) SNOW (INCL. KEYS) | 86 | 586 32 73-01 | CYLINDER HEAD BOLT KIT (4) (136-179-208-254CC) |
| 54 | 532 44 30-59 | KEY SET - RED (2) (SNOW) | 87 | 586 32 69-01 | CC COVER BOLT KIT (6) (179-208-254CC) |
| | | | 88 | 586 32 68-01 | MUFFLER MTG STUD KIT (2) |
| | | | 89 | 587 12 48-01 | SPEED CONTROL KNOB, GEN II |
| | | | 91 | 587 52 57-01 | CRANKSHAFT GASKET KIT 179-208CC |
| | | | 9999 | 586 32 62-01 | HIGH ALTITUDE JET (>5,000 FEET)(208CC L10-1 CARBURETOR) |
| | | | 9999 | 579 80 64-01 | BOLT KIT BLWR HSG-HEATER BOX TANK SKIRT |

