



Parts Manual

Zero Turn Mower / Z 242F

967 271801-00

Please read the operator manual carefully and make sure you understand the instructions before using the machine.



When you need spare parts or support in service questions, warranty issues, etc., please consult the following professional:

This manual belongs to the machine with the manufacturing number:	Engine	Transmission

Manufacturing Number

The machine's manufacturing number can be found on the printed plate affixed to the engine compartment.

Stated on the plate, from the top are:

- The machine's type designation (I.D.).
- The manufacturer's type number (Model).
- The machine's serial number (Serial no.)

Please have the type designation and serial number available when ordering spare parts.

CONTENTS

FRAME	4
ENGINE MOUNTING, GUARDS & MUFFLER	6
STEERING	8
IGNITION SYSTEM.....	10
BRAKE / LIFT	12
HYDRAULIC PUMP-MOTOR.....	14
WHEELS & TIRES	16
MOWER DECK / CUTTING DECK	18
SEAT	20
DECALS	22

Illustrations may or may not represent the actual assemblies and it is not recommended to use this manual as a guide to assemble or disassemble the mower.

NOTE: All fasteners are Grade 5 unless otherwise specified.

FRAME

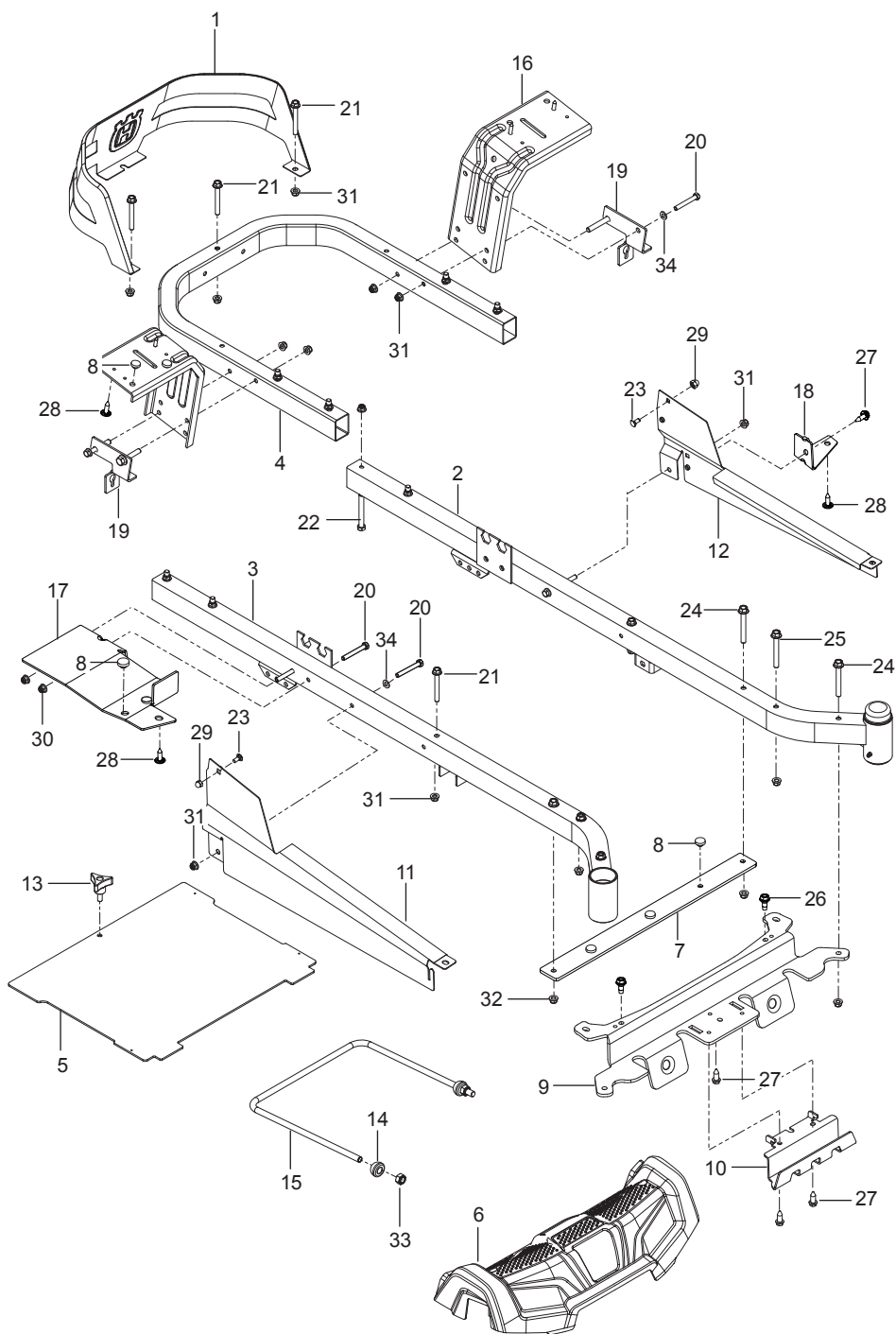

Ref.	Part No.	Qty	Description
1	585 03 98-02	1	Guard, Rear Blk
2	510 17 75-03	1	Frame, Front Right Org
3	510 17 74-03	1	Frame, Front Left Org
4	584 99 10-02	1	Frame, Rear Tube Org
5	522 84 29-02	1	Foot Plate w/ Safety Decal
6	585 52 24-01	1	Cover, Footrest
7	585 52 30-04	1	Support, Footrest
8	585 98 93-01	7	Grommet, Bumper
9	585 52 31-04	1	Cross Member
10	585 52 32-04	1	Plate, Skid Silv
11	585 33 16-02	1	Cover, Rail Right
12	585 33 15-02	1	Cover, Rail Left
13	539 10 44-11	1	Knob w/ Stud
14	532 19 52-63	2	Bushing, Pivot
15	521 93 81-01	1	Link, Front Suspension
16	580 50 13-02	2	Support, Fender Blk
17	585 52 34-04	1	Support, Console Right
18	585 52 36-04	1	Support, Console Left
19	585 47 43-02	2	Bracket, Bypass Rod
20	874 78 05-36	8	Bolt 5/16-18 x 2-1/4
21	874 49 05-44	5	Bolt 5/16-18 x 2-3/4
22	874 78 06-48	8	Bolt 3/8-16 x 3
23	585 94 00-01	2	Bolt 5/16-18 x 1 Carriage
24	577 11 77-01	4	Bolt 3/8-16 x 3
25	586 65 43-01	2	Bolt 3/8-16 x 3 Shoulder
26	586 88 11-01	2	Bolt 5/16-18 Shoulder
27	817 00 05-10	4	Screw 5/16-18 x 5/8 Washer Head
28	532 41 63-58	6	Screw #10-24 x 3/4 Hex Head
29	585 93 81-01	2	Nut 5/16-18 Acorn
30	873 90 05-00	2	Nut 5/16-18 Hex Flange Lock
31	539 11 28-99	9	Nut 5/16-18 Hex Flange Nyloc
32	521 99 65-01	8	Nut 3/8-16 Hex Flange Nyloc
33	539 11 91-24	2	Nut 7/16-14 Hex Nyloc
34	819 11 11-16	6	Washer 5/16 SAE Flat

ENGINE MOUNTING, GUARDS & MUFFLER

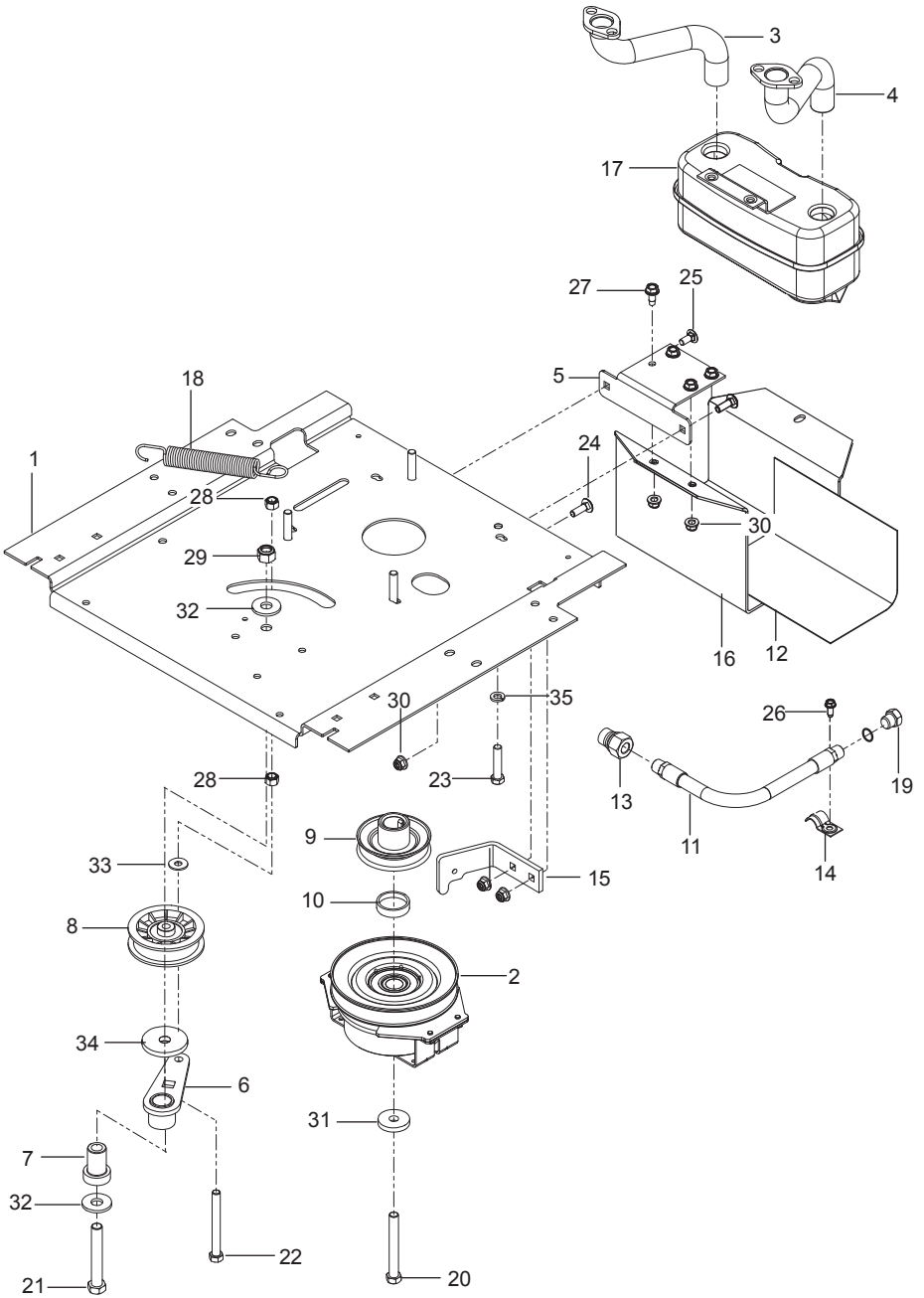

Ref.	Part No.	Qty	Description
1	588 01 71-02	1	Plate, Engine Blk
2	587 24 16-01	1	Clutch
3	583 95 57-01	1	Tube, Exhaust Right
4	583 95 56-01	1	Tube, Exhaust Left
5	581 88 67-02	1	Bracket, Muffler Blk
6	532 44 81-45	1	Arm, Idler
7	539 10 12-31	1	Spindle, Idler
8	539 11 03-11	1	Pulley, Idler
9	587 53 74-01	1	Pulley, Engine
10	587 66 01-01	1	Spacer
11	584 82 55-01	1	Hose, Drain
12	539 13 28-59	1	Shield, Muffler
13	522 59 90-01	1	Adapter, Oil Drain
14	539 10 13-63	1	Clamp
15	587 63 33-02	1	Stop, Clutch Blk
16	587 45 12-02	1	Guard, Muffler Blk
17	539 13 16-04	1	Muffler Assembly
18	532 19 61-05	1	Spring, Deck Drive
19	585 80 71-01	1	Plug, Hose
20	581 33 28-03	1	Bolt 7/16-20 x 2-1/2
21	874 78 08-52	1	Bolt 1/2-13 x 3-1/4
22	874 52 06-56	1	Bolt 3/8-16 x 3-1/2
23	539 97 69-49	4	Bolt 3/8-16 x 1-3/4
24	872 14 05-06	2	Bolt 5/16-18 x 1 Round Head Square Neck
25	872 14 05-08	2	Bolt 5/16-18 x 3/4 Round Head Square Neck
26	817 49 04-10	1	Screw 1/4-20 x 5/8 Thread Form
27	817 49 05-12	4	Screw 5/16-18 x 3/4 Thread Form
28	539 97 69-79	2	Nut 3/8-16 Hex Nyloc
29	873 80 08-00	1	Nut 1/2-13 Hex Nyloc
30	539 11 28-99	5	Nut 5/16-18 Hex Flange Nyloc
31	532 12 61-97	1	Washer, Clutch
32	819 18 22-12	2	Washer 1/2 Flat
33	819 12 14-14	2	Washer 5/16 Std Flat
34	539 11 26-70	1	Washer, Heavy
35	810 03 06-00	4	Washer 3/8 Splt Lock
	NOT SHOWN		
	-----	1	Engine, Kawasaki FX651V 21.5 Hp For Engine Replacement Parts, See a Kawasaki Dealer

STEERING

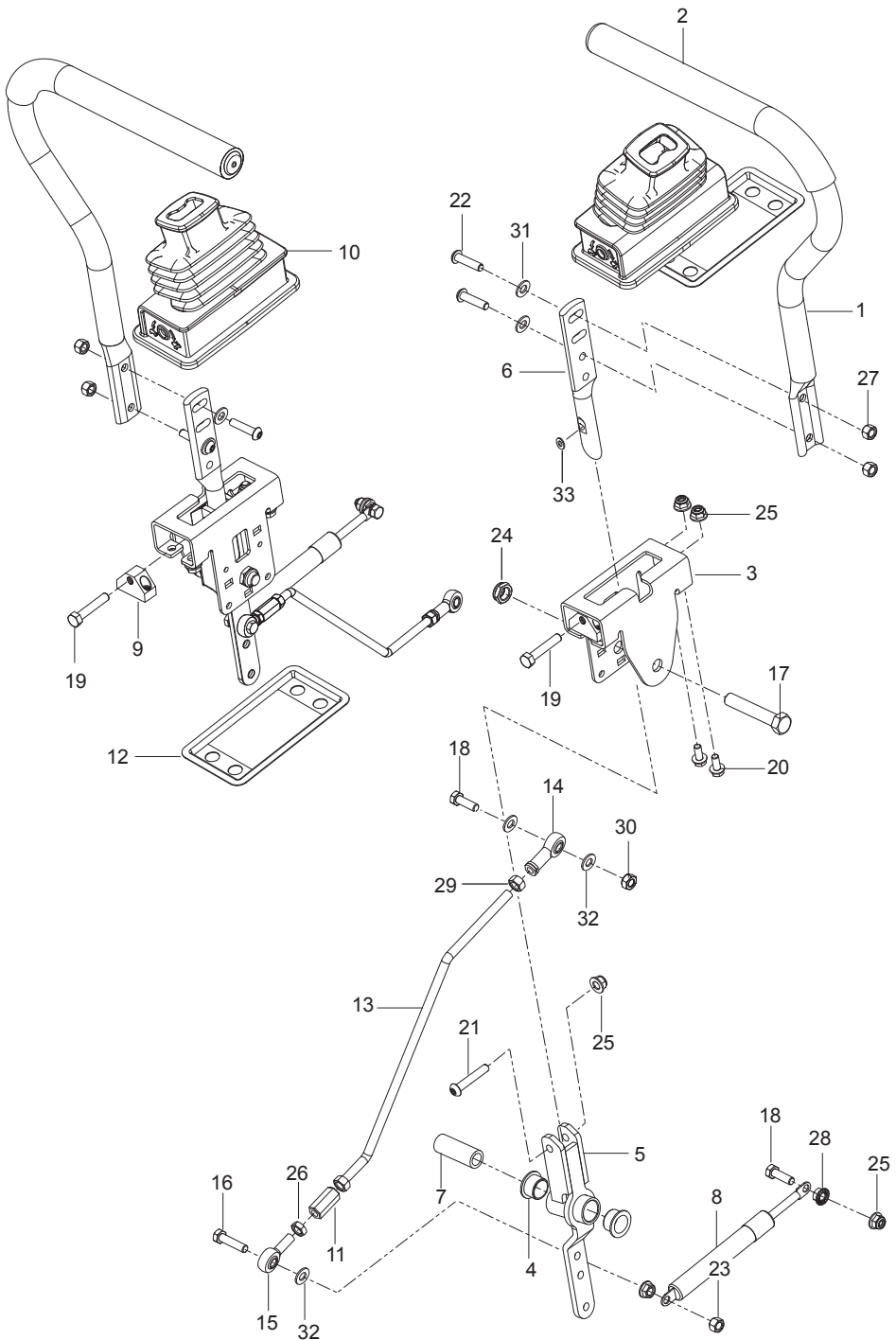

Ref.	Part No.	Qty	Description
1	581 82 67-01	2	Lever w/ Grip
2	525 39 29-01	2	Grip, Foam
3	585 12 47-05	2	Bracket, Control
4	539 13 15-18	4	Bearing, Flanged
5	576 14 03-01	2	Control, Lever
6	587 60 17-02	2	Lever, Handle
7	584 92 72-01	2	Spacer, Pivot Control
8	539 10 27-20	2	Dampener
9	581 43 75-01	2	Block, Tracking
10	585 83 16-01	2	Boot, Steering
11	539 11 66-89	2	Coupler, Rod End
12	585 48 82-02	2	Flange, Boot
13	580 62 42-01	2	Rod, Motion Control
14	539 11 57-29	2	Rod End Right
15	539 11 66-90	2	Rod End Male Left
16	874 78 05-28	2	Bolt 5/16-18 x 1-3/4 Tap Bolt
17	874 78 08-44	2	Bolt 1/2-13 x 2-3/4
18	874 78 05-16	4	Bolt 5/16-18 x 1 Thread Form
19	585 98 61-01	2	Bolt 5/16-18 x 1-1/4
20	874 49 05-12	8	Bolt Hex Flange 5/16-18 x 3/4
21	587 88 53-01	2	Screw 5/16-18 x 1-3/4 Button Head
22	585 98 59-01	4	Screw 5/16-18 x 1-1/8 Button Head Black
23	873 80 05-00	2	Nut 5/16-18 Hex Nyloc
24	539 10 80-10	2	Nut 1/2-13 Hex Jam Nyloc Grade 2
25	539 11 28-99	12	Nut 5/16-18 Hex Flange Nyloc
26	873 70 05-00	2	Nut 5/16-24 Hex Jam Left Hand
27	585 98 60-01	4	Nut 5/16-18 Hex Nyloc Black
28	539 99 05-85	4	Nut 5/16-18 Hex Whiz Lock
29	539 99 02-23	4	Nut 5/16-24 Hex
30	539 11 56-17	2	Nut 5/16-18 Thin Nyloc
31	586 30 91-01	4	Washer 5/16 SAE Flat Black
32	819 11 11-16	6	Washer 5/16 SAE Flat
33	587 61 42-01	2	Washer 11/32

IGNITION SYSTEM

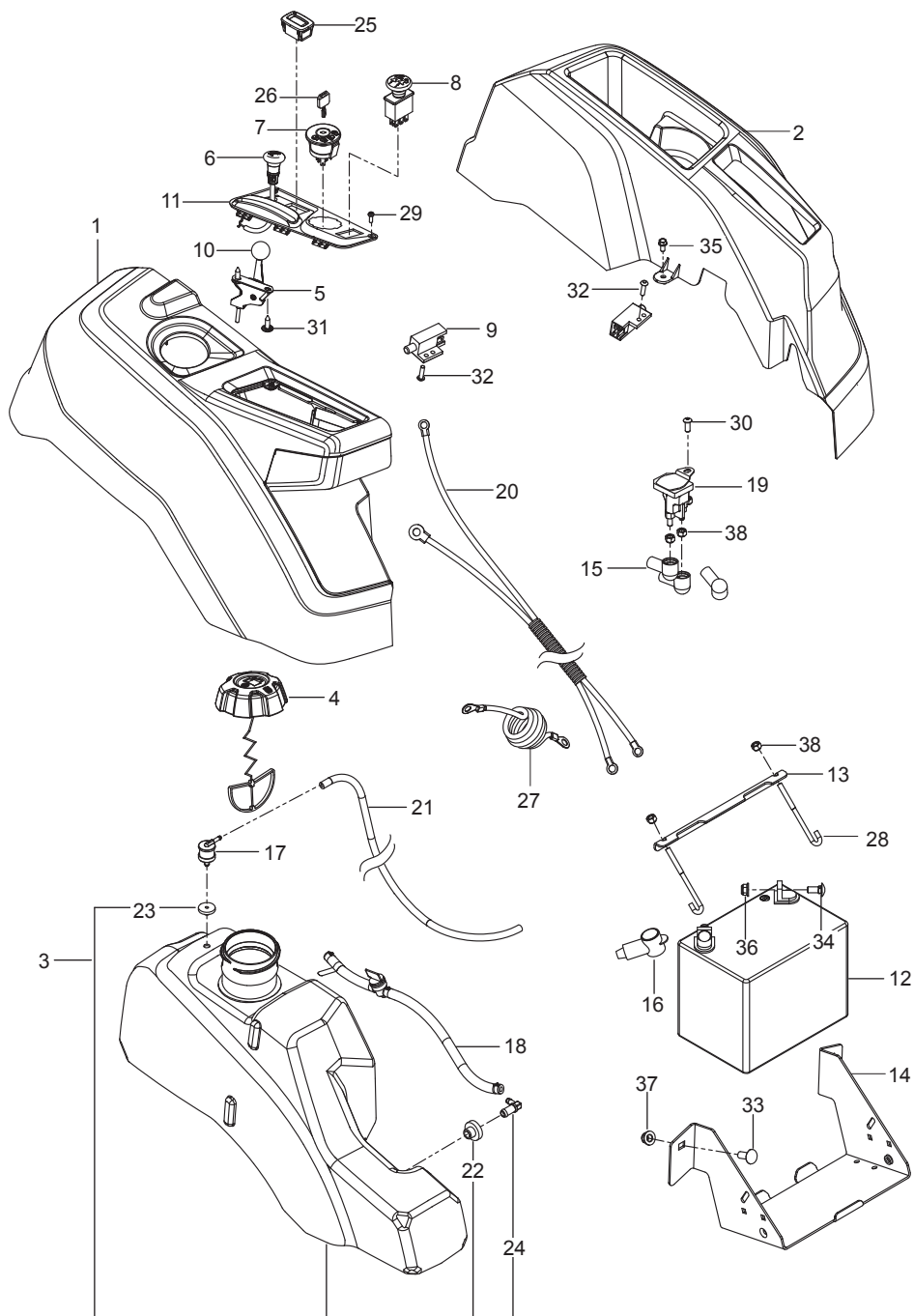

Ref.	Part No.	Qty	Description
1	585 52 28-01	1	Assembly, Fender, Right Gry
2	586 62 12 01	1	Assembly, Fender, Left Gry
3	578 18 06-02	1	Assembly, Fuel Tank
4	585 12 49-01	1	Cap, Fuel w/ Tether
5	539 11 24-38	1	Cable, Throttle
6	586 88 15-01	1	Control, Choke
7	539 10 75-41	1	Switch, Ignition
8	582 10 76-02	1	Switch, Clutch
9	587 60 15-01	2	Switch, Interlock
10	539 13 30-49	1	Knob
11	585 52 27-01	1	Panel, Control
12	579 41 16-01	1	Battery
13	510 03 00-03	1	Bracket, Battery
14	582 60 96-02	1	Box, Battery Blk
15	532 13 15-63	3	Terminal Cover
16	539 10 27-59	1	Terminal Cover
17	576 61 81-01	1	Valve, Fuel Check
18	586 12 39-04	1	Assembly, Fuel Line w/ Valve
19	582 04 28-01	1	Solenoid
20	587 19 86-01	1	Harness, Battery Cable
21	587 04 45-50	1	Hose 3/16 x 50" Vapor
22	532 00 36-45	1	Grommet, Rubber
23	532 43 74-92	1	Grommet, Check Valve
24	532 13 92-77	1	Elbow
25	586 16 18-01	1	Meter, Service
26	532 14 04-01	1	Key, Ignition
27	539 10 33-06	1	Cable, Battery Positive
28	588 83 94-01	2	J Hook
29	545 22 71-01	2	Screw 6-19 x 7/16 Pan Head
30	539 11 12-29	1	Screw 1/4-20 x 5/8 Button Socket
31	532 14 18-41	2	Screw 10-16 x .65
32	586 93 60-01	2	Screw #10-24 x 1/2 Socket Head
33	539 99 06-45	2	Bolt 3/8-16 x 1 Round Head Square Neck
34	872 14 05-06	2	Bolt 5/16-18 x 3/4 Round Head Square Neck
35	817 49 04-08	2	Bolt 1/4-20 x 1/2
36	539 11 28-99	2	Nut 5/16-18 Flange Nyloc
37	521 99 65-01	2	Nut 3/8-16 Hex Flange Nyloc
38	873 80 04-00	5	Nut 1/4-20 Hex Nyloc
	NOT SHOWN		
	586 33 73-01	1	Harness, Wiring
	532 10 97-48	1	Relay 40A

BRAKE / LIFT

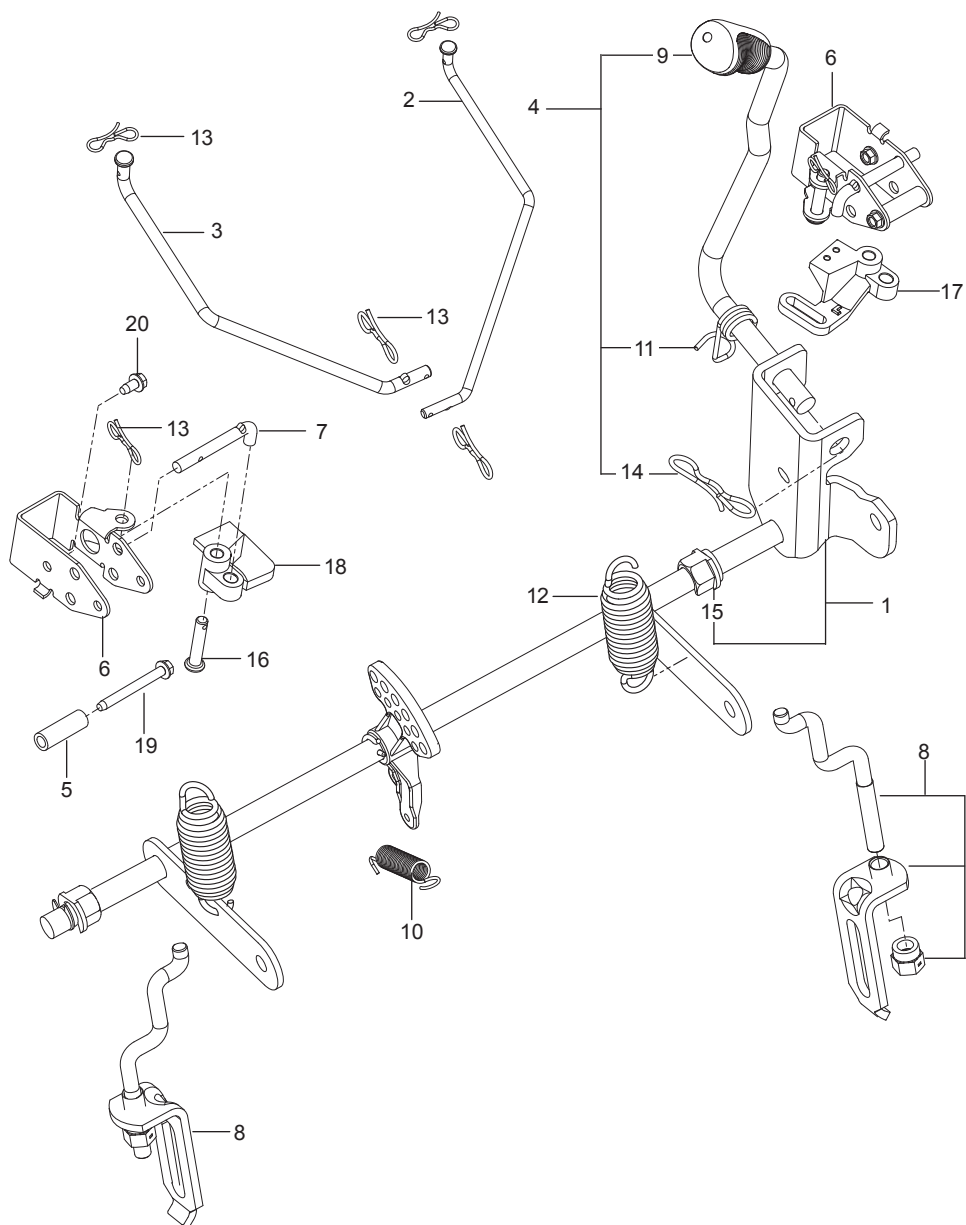

Ref.	Part No.	Qty	Description
1	587 62 31-01	1	Assembly, Shaft w/ Nuts, E-Rings
2	586 45 71-01	1	Link, Brake Left
3	586 45 72-01	1	Link, Brake Right
4	587 62 29-01	1	Assembly, Lift Handle
5	580 48 61-01	2	Spacer
6	585 68 21-02	2	Bracket, Bellcrank
7	585 68 20-01	2	Pushrod
8	587 62 30-01	2	Assembly, Centering Lnk
9	532 44 50-60	1	Grip, Handle Black
10	586 86 76-01	1	Spring
11	532 19 63-14	1	Spring
12	539 11 87-62	2	Spring
13	587 22 53-01	6	Clip
14	532 19 42-09	1	Clip
15	510 18 49-01	2	Nut, Plastic
16	585 70 14-01	2	Pin 1/2 Clevis
17	586 45 74-01	1	Bellcrank Left
18	586 45 75-01	1	Bellcrank Right
19	586 56 13-01	2	Screw 1/4-20 x 2-1/4 Thread Roll
20	532 13 77-29	2	Screw 1/4-20 x 5/8 Thread Roll

HYDRAULIC PUMP-MOTOR

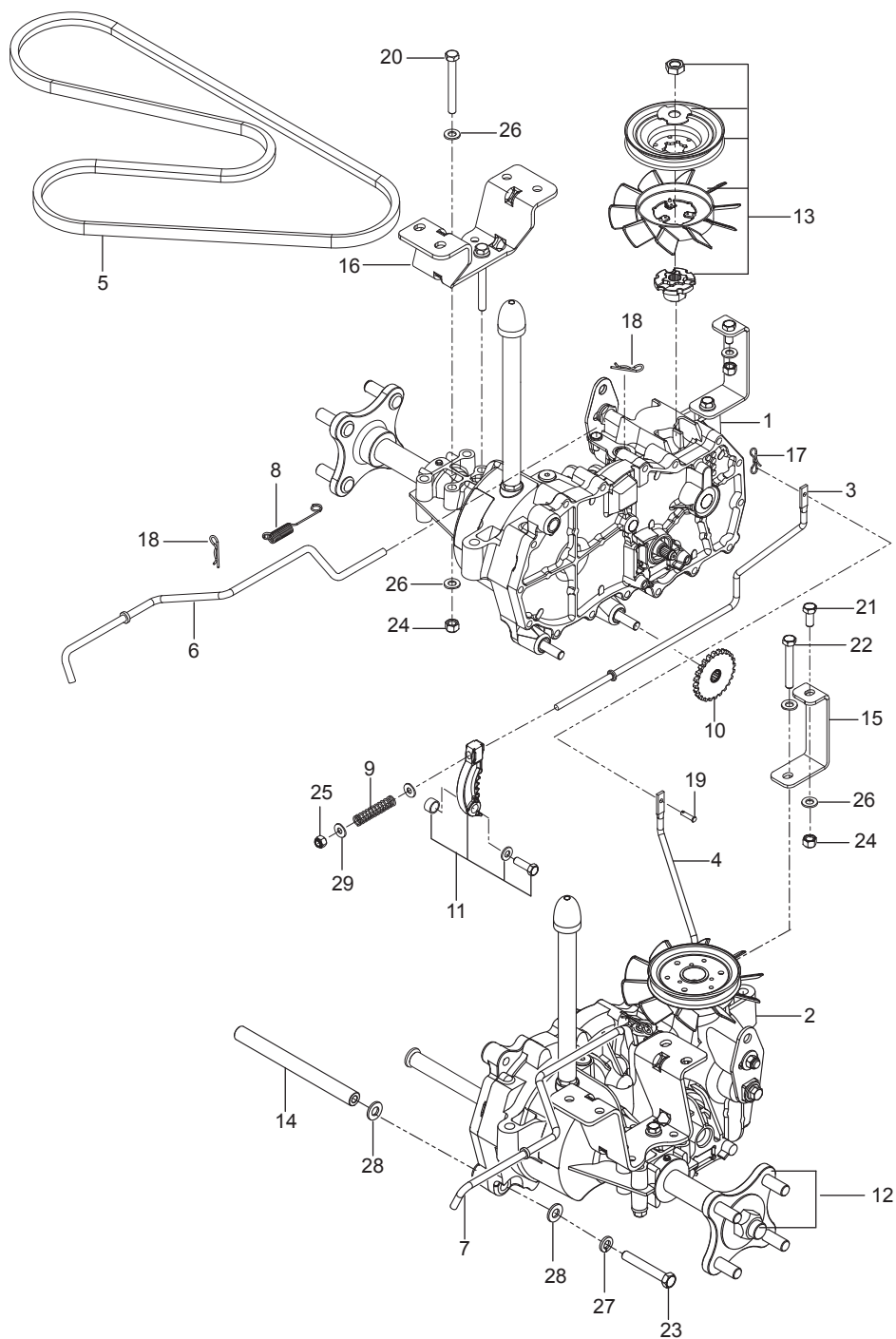

Ref.	Part No.	Qty	Description
1	510 37 56-01	1	EZT, Left
2	510 37 56-02	1	EZT, Right
3	574 03 05-01	1	Rod, EZT Brake Left
4	574 03 05-02	1	Rod, EZT Brake Right
5	539 11 04-11	1	Belt, EZT
6	585 47 44-01	1	Rod, Bypass Left
7	585 47 45-01	1	Rod, Bypass Right
8	586 66 51-01	2	Spring, Bypass
9	539 11 03-42	2	Spring, Brake Rod
10	539 12 00-80	2	Cog, Brake Disc
11	539 12 00-79	2	Assembly Kit, Brake Arm
12	575 50 70-01	1	Assembly Kit, Hub w/ Nuts
13	501 40 36-02	2	Assembly Kit, Blade, Pulley
14	510 18 41-04	2	Spacer Tube
15	580 80 65-02	2	Support, EZT Front
16	580 80 66-02	2	Mount, EZT Rear Blk
17	587 22 53-01	1	Clip
18	539 97 69-88	4	Clip
19	587 11 53-01	1	Pin, Clevis
20	874 78 05-44	4	Bolt 5/16-18 x 2-3/4
21	874 78 05-12	2	Bolt 5/16-18 x 3/4
22	874 78 05-36	2	Bolt 5/16-18 x 2-1/4
23	874 78 06-40	4	Bolt 3/8-16 x 2-1/2
24	873 80 05-00	8	Nut 5/16-18 Hex Nyloc
25	873 80 04-00	2	Nut 1/4-20 Hex Nyloc
26	819 11 11-16	16	Washer 5/16 SAE Flat
27	810 03 06-00	4	Washer 3/8 Splt Lock
28	819 13 13-16	8	Washer 3/8 SAE Flat
29	819 09 10-16	4	Washer 1/4 SAE Flat

WHEELS & TIRES

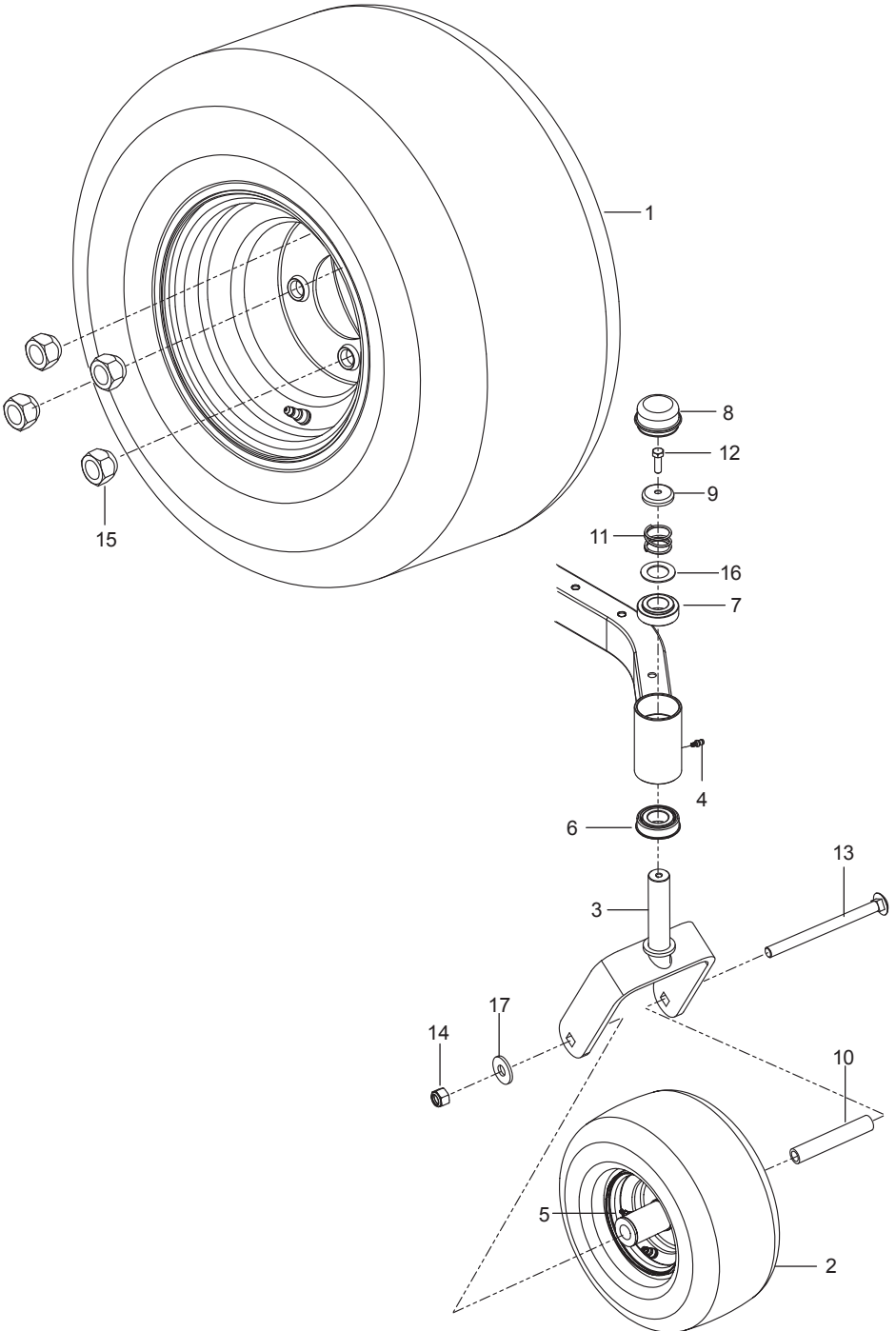

Ref.	Part No.	Qty	Description
1	581 19 73-01	2	Assembly, Wheel Rear 18 x 8.5
2	576 58 86-02	2	Wheel Assembly Caster 11 x 6-5
3	586 65 03-02	2	Yoke Orange
4	539 11 56-38	2	Zerk 3/16 Drive
5	539 10 33-00	2	Zerk
6	539 11 26-60	2	Bearing, Flanged
7	539 11 79-01	2	Bushing, Caster
8	539 10 25-35	2	Grease Cap
9	539 11 57-49	2	Plug, Caster
10	585 99 54-01	2	Spacer, Pivot
11	539 11 57-47	2	Spring, Caster
12	874 95 05-16	2	Bolt, Hex 5/16-18 x 1 Nylon Patch
13	576 60 15-01	2	Bolt 1/2-13 x 7 Round Head Square Neck
14	873 93 08-00	2	Nut 1/2-13 Hex Center Lock
15	539 10 11-73	8	Nut 1/2 Lug
16	539 11 56-75	2	Washer
17	819 18 22-12	2	Washer 9/16

MOWER DECK / CUTTING DECK

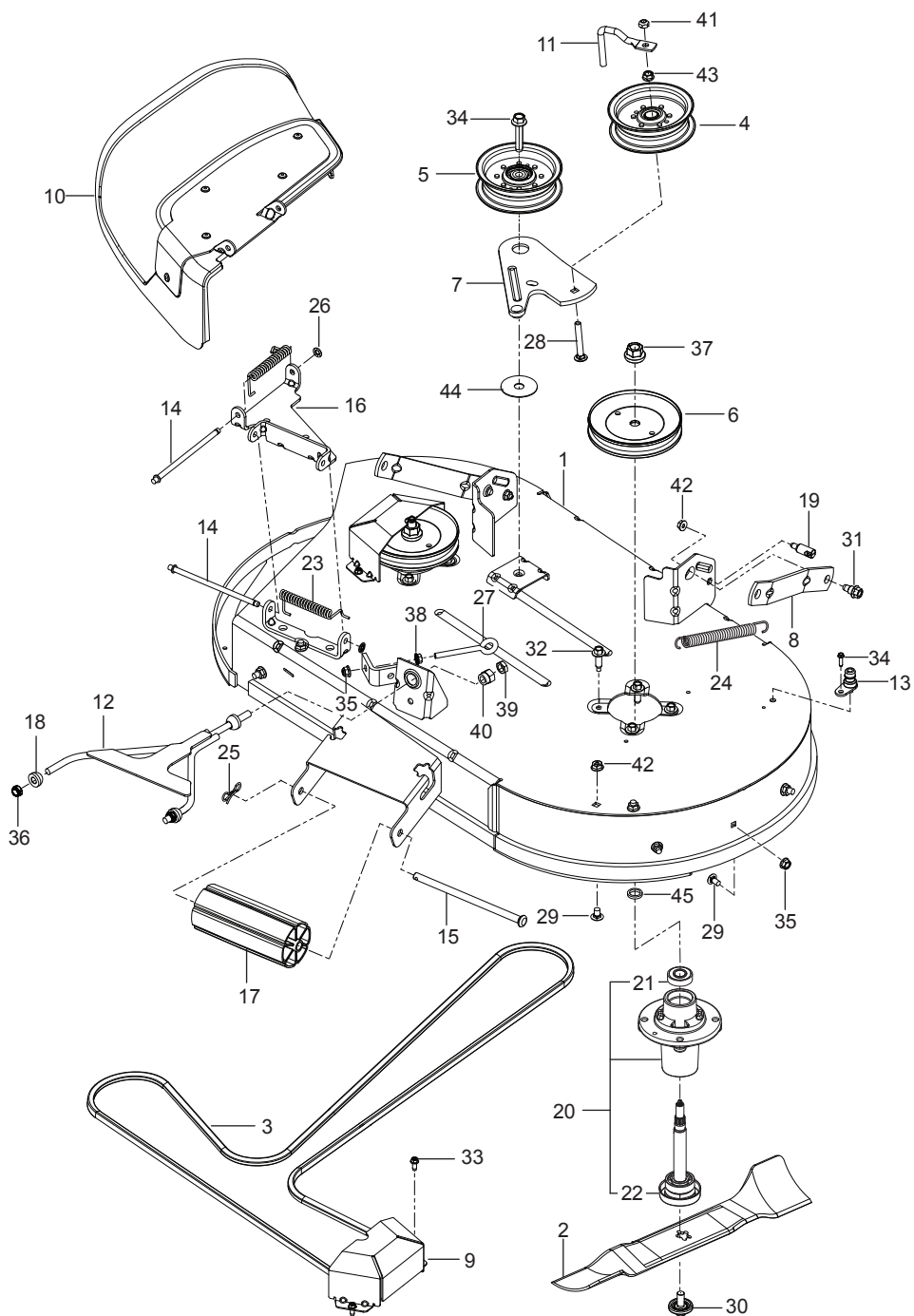

Ref.	Part No.	Qty	Description
1	501 06 34-01	1	Deck w/ Safety Decals Org
2	586 91 81-01	2	Blade, Bagging
3	587 27 00-01	1	Belt
4	532 19 61-06	1	Pulley, Idler
5	532 19 61-04	1	Pulley, Idler
6	532 19 97-91	2	Pulley, Mandrel
7	586 87 40-02	1	Arm, Clutch Blk
8	587 14 05-02	2	Arm, Suspension Blk
9	586 93 68-02	2	Cover, Belt Org
10	587 30 57-01	1	Assy, Deflector Org
11	532 19 84-68	1	Keeper, Belt
12	588 61 09-02	1	Link, Front
13	532 41 55-98	1	Port, Washout
14	532 13 14-91	2	Rod, Hinge
15	532 17 91-27	1	Rod, Nose Roller
16	586 91 80-02	1	Bracket, Hinge Org
17	532 17 60-66	1	Roller, Nose
18	532 19 52-63	3	Bushing, Pivot
19	532 19 51-61	2	Stud w/ Anti-Rotate
20	539 13 18-98	2	Mandrel, Cast Iron
21	532 11 04-85	1	Bearing, Ball
22	532 18 72-91	1	Shaft, Mandrel
23	587 35 47-01	2	Spring, Deflector
24	532 19 72-51	1	Spring, Drive
25	532 19 42-08	1	Pin 5/16 Bowtie
26	532 11 04-52	2	Push Nut
27	539 11 55-74	1	Eyebolt 5/16 x 3-1/2
28	872 14 06-20	1	Bolt 3/8-16 x 2-1/2 Round Head Square Neck
29	872 11 05-05	7	Bolt 5/16-18-5/8 Round Head Square Neck
30	532 19 30-03	2	Bolt/Washer 7/16-20
31	532 19 65-39	2	Bolt, Shoulder
32	584 95 39-01	8	Screw 5/16-18 x 1 Thread Roll
33	532 13 77-29	4	Screw 1/4-20 x 5/8 Thread Roll
34	588 43 83-01	1	Screw 7/16-14 x 2-1/8 Hex Washer Head
35	539 11 28-99	8	Nut 5/16-18 Hex Flange Nyloc
36	539 11 91-24	2	Nut 7/16-14 Hex Nyloc
37	532 40 02-34	2	Nut 9/16 Top Center Lock
38	539 99 05-85	1	Nut 5/16-18 Hex Whiz Lock
39	873 36 07-00	1	Nut 7/16-20 Hex Jam
40	532 17 59-94	1	Nut 7/16-20 Lift Link
41	873 90 06-00	1	Nut 3/8-16 Flange Lock
42	873 90 05-00	5	Nut 5/16-18 Hex Flange Lock
43	873 68 06-00	1	Nut 3/8-16 Crown Lock
44	532 17 85-15	1	Washer, Flat Hardened
45	532 18 76-90	2	Washer, Spacer

SEAT

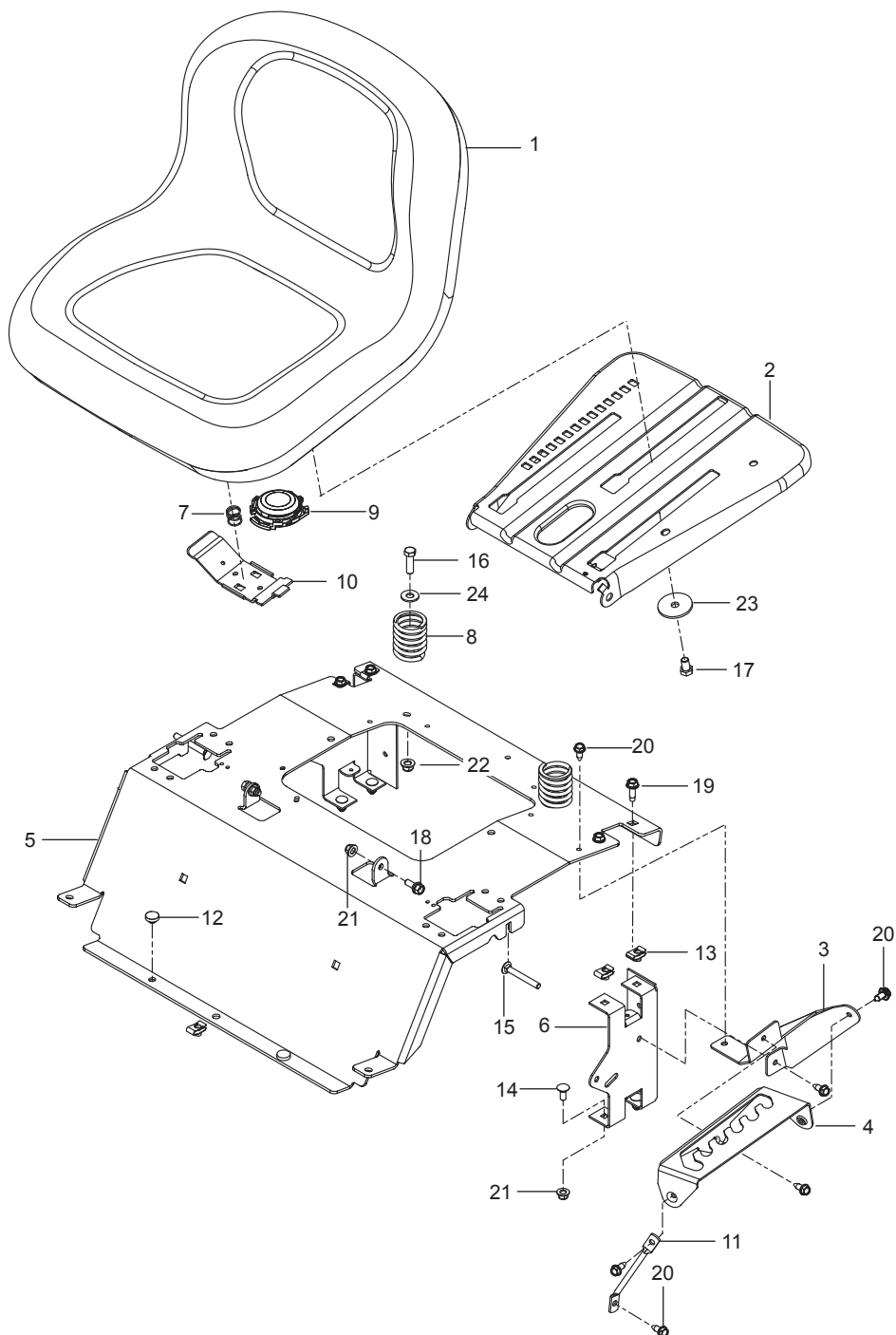

Ref.	Part No.	Qty	Description
1	532 43 98-22	1	Seat
2	532 19 69-77	1	Pan, Seat
3	586 22 08-02	1	Plate, Lift Support
4	586 22 12-02	1	Plate, Deck Lift
5	577 26 05-03	1	Support, Seat Orange
6	580 30 82-02	2	Support, Seat Rear Black
7	532 19 82-00	1	Spring, Latch
8	587 61 33-01	2	Spring, Seat
9	532 40 15-45	1	Switch, Seat
10	532 19 76-61	1	Handle, Slide
11	586 42 86-01	1	Leg, Support
12	585 98 93-01	2	Grommet, Bumper
13	539 10 47-63	5	Retainer, U Type
14	872 14 05-06	4	Bolt 5/16-18 x 3/4 Round Head Square Neck
15	510 42 27-01	2	Bolt 5/16-18 x 2-1/2 Round Head Square Neck
16	874 78 06-20	2	Bolt 3/8-16 x 1-1/4
17	874 78 06-10	1	Bolt 3/8-16 x 5/8
18	539 11 03-03	2	Bolt 5/16-18 Shoulder
19	817 49 05-12	4	Screw 5/16-18 x 3/4 Thread Form
20	817 00 05-10	6	Screw 5/16-18 x 5/8 Washer Head
21	539 11 28-99	4	Nut 5/16-18 Hex Flange Nyloc
22	521 99 65-01	2	Nut 3/8-16 Hex Flange Nyloc
23	539 11 18-97	1	Washer 3/8 Special
24	819 14 16-14	2	Washer 3/8 Std Flat
	NOT SHOWN - OPTIONAL		
	532 42 14-99	1	Kit, Arm Rest

DECALS

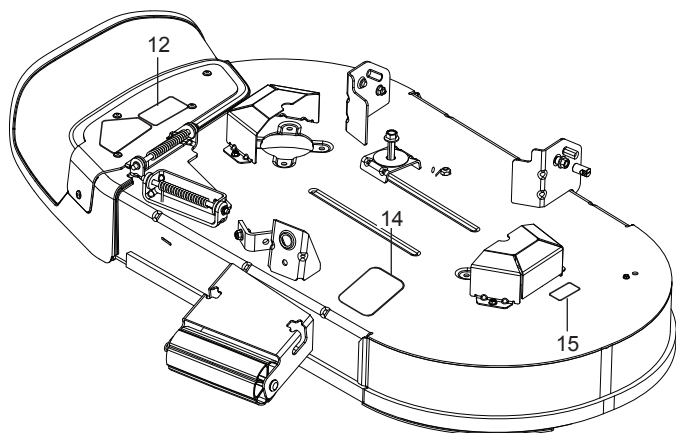
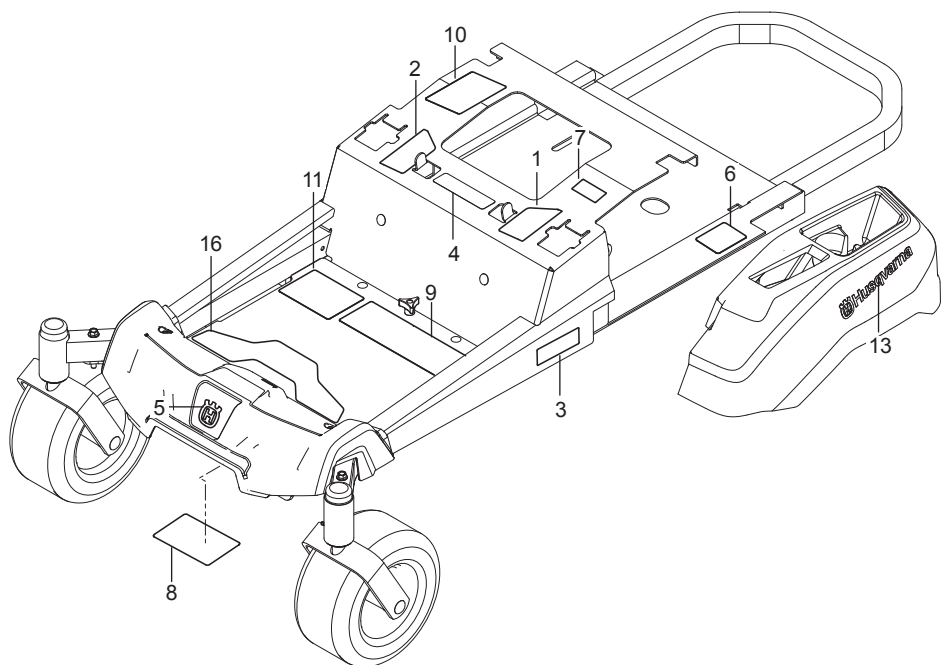

Ref.	Part No.	Qty	Description
1	587 59 56-01	1	Decal, Steer / Brake Left
2	587 59 55-01	1	Decal, Steer / Brake Right
3	587 76 92-01	2	Decal, Z 242F
4	539 10 57-45	1	Decal, Battery Warning
5	532 42 86-77	1	Decal, Crown
6	539 10 83-85	1	Decal, Do Not Tow
7	539 10 83-86	1	Decal, Exit Mower
8	539 10 98-97	1	Decal, Service
9	583 93 40 01	1	Decal, Safety Warnings
10	532 42 38-29	1	Decal, Responsibility
11	588 03 51-01	1	Decal, Start
12	586 97 88-01	1	Decal, Deflector
13	577 46 90-01	2	Decal, Husqvarna
14	581 58 00-01	1	Decal, Belt Routing
15	581 72 43-01	1	Decal, No Step
16	587 00 07-01	1	Pad, Abrasive

www.husqvarna.com

115 84 81-27 Rev A
2016-06-30