

ILLUSTRATED PARTS LIST

MODEL NUMBER ST 224

PRODUCT NUMBER 961 93 00-96

MFG. ID. NUMBER 96193009604

REPAIR PARTS

AUGER HOUSING / IMPELLER ASSEMBLY

SNOW THROWER - MODEL NO. ST224 (96193009604), PRODUCT NO. 961 93 00-96

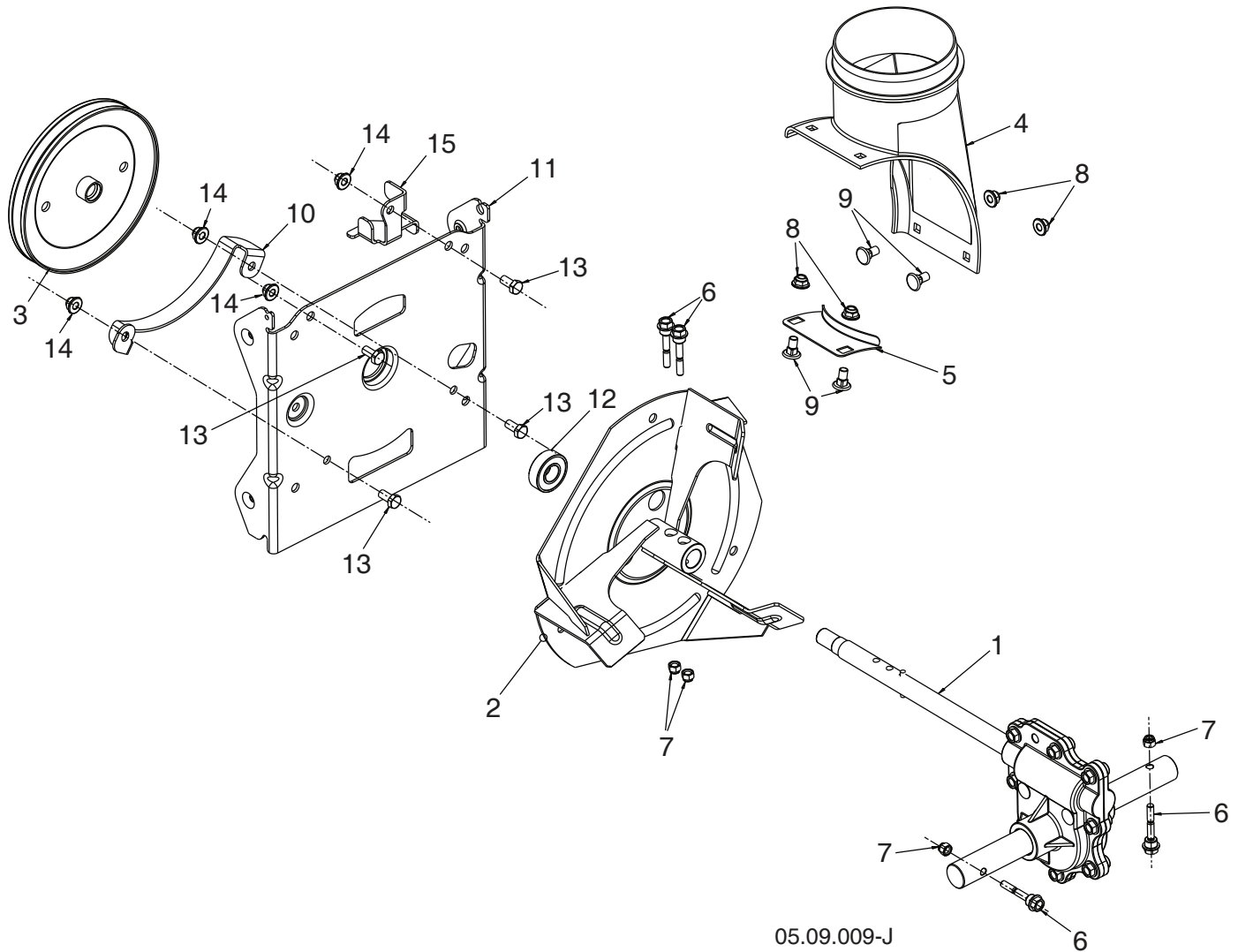

NOTE: All component dimensions given in U.S. inches. 1 inch = 25.4 mm
IMPORTANT: Use only Original Equipment Manufacturer (O.E.M.) replacement parts.
Failure to do so could be hazardous, damage your snow thrower and void your warranty.

REPAIR PARTS

AUGER HOUSING / IMPELLER ASSEMBLY

SNOW THROWER - MODEL NO. **ST224** (96193009604), PRODUCT NO. 961 93 00-96

KEY NO.	PART NO.	DESCRIPTION
1	501 14 96-01	GEARBOX AUGER
2	586 60 72-02	IMPELLER STEEL
3	587 40 24-01	PULLEY IMPELLER – SCREW ON
4	585 05 69-01	CHUTE DISCHARGE BASE
5	532 18 40-95	BRACKET CORNER DISCHARGE BASE
6	588 07 75-01	BOLT SHEAR 1/4-20
7	873 80 04-00	NUT NYLOCK 1/4-20
8	585 69 13-01	NUT FLANGE NYLOCK 5/16-18 - BLK
9	585 69 12-01	BOLT CARRIAGE WAFER HEAD 5/16-18 X 5/8 BLK
10	581 63 20-02	BRACKET BELT KEEPER LOWER
11	581 59 25-02	BRACKET INTERFACE
12	532 19 87-91	BEARING BALL
13	532 16 31-83	SCREW HEX HEAD 5/16-18 X 5/8
14	532 42 79-42	NUT FLANGE NYLOCK 5/16-18
15	587 58 72-02	LOWER AUGER BELT GUIDE

NOTE: All component dimensions given in U.S. inches. 1 inch = 25.4 mm
IMPORTANT: Use only Original Equipment Manufacturer (O.E.M.) replacement parts.
Failure to do so could be hazardous, damage your snow thrower and void your warranty.

REPAIR PARTS

AUGER HOUSING / IMPELLER ASSEMBLY

SNOW THROWER - MODEL NO. ST224 (96193009604), PRODUCT NO. 961 93 00-96

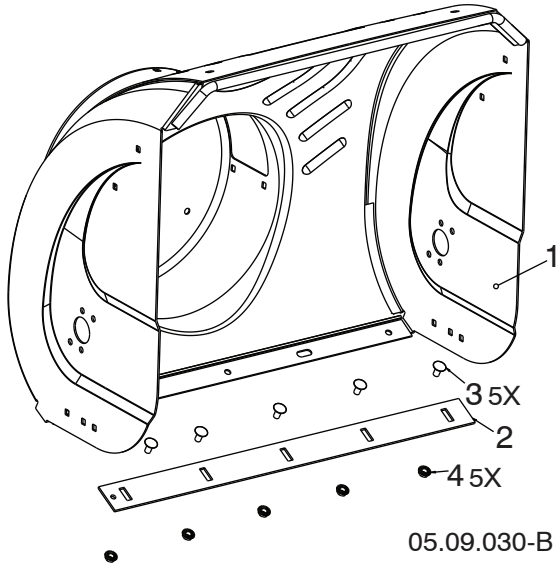

KEY NO.	PART NO.	DESCRIPTION
1	581 70 83-90	AUGER HOUSING
2	532 40 78-25	SCRAPER BAR
3	872 27 05-05	CARRIAGE BOLT 5/16-18 X .625 GR5
4	532 15 53-77	NUT 5/16-18

05.09.030-B

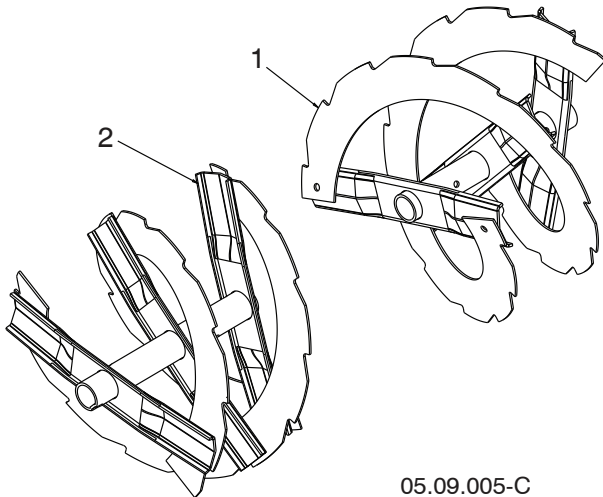

KEY NO.	PART NO.	DESCRIPTION
1	532 42 10-72	AUGER WELD RIB LH 24
2	532 42 10-73	AUGER WELD RIB RH 24

05.09.005-C

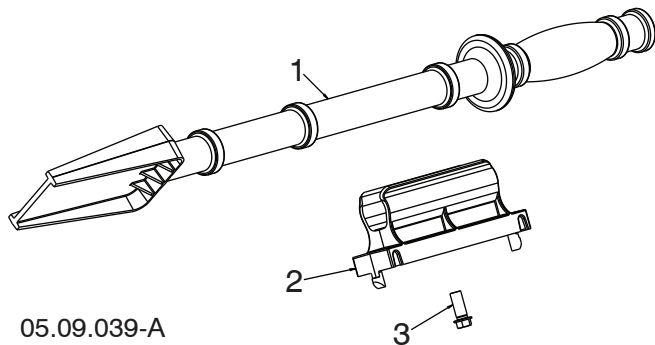

KEY NO.	PART NO.	DESCRIPTION
1	532 19 21-99	TOOL CLEANOUT
2	532 40 54-00	CLIP CLEANOUT TOOL
3	532 19 41-89	SCREW HEX WASHER 13-16 X 5/8

05.09.039-A

NOTE: All component dimensions given in U.S. inches. 1 inch = 25.4 mm
IMPORTANT: Use only Original Equipment Manufacturer (O.E.M.) replacement parts. Failure to do so could be hazardous, damage your snow thrower and void your warranty.

REPAIR PARTS

AUGER HOUSING / IMPELLER ASSEMBLY

SNOW THROWER - MODEL NO. **ST224** (96193009604), PRODUCT NO. 961 93 00-96

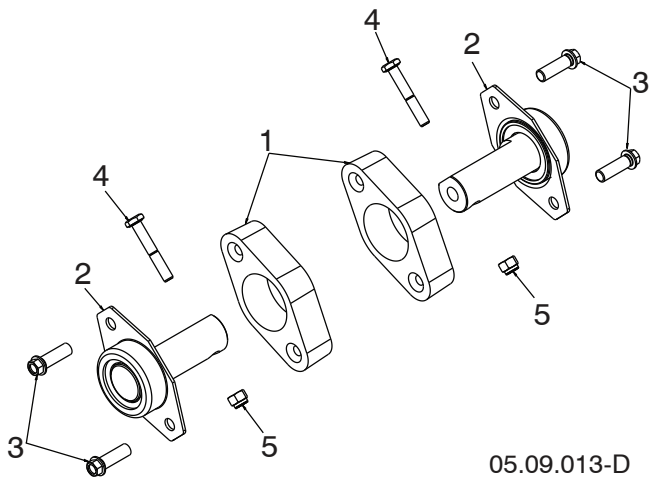

KEY NO.	PART NO.	DESCRIPTION
1	532 18 81-70	PLASTIC RETAINER
2	532 42 77-62	AUGER BALL BEARING
3	584 29 94-01	SCREW HI-LO 5/16-14 X 1.00 - BLK
4	874 78 04-26	BOLT SHEAR HEX HD 1/4-20
5	873 80 04-00	NUT 1/4-20

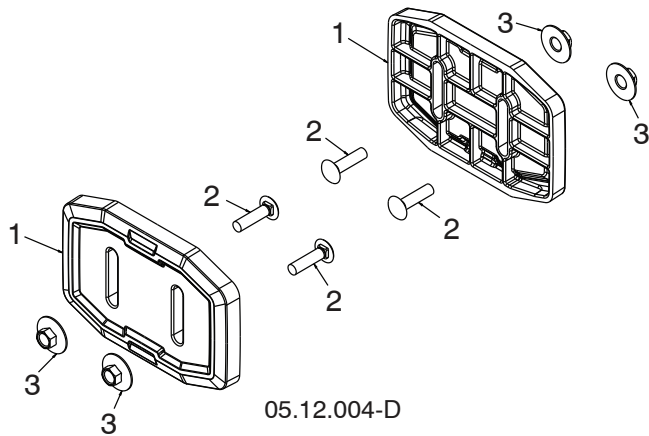

KEY NO.	PART NO.	DESCRIPTION
1	583 83 88-01	SKID SHOE UHMW
2	585 80 29-01	BOLT CARR BLK 5/16-18 X 1.25
3	585 80 28-01	NUT HEX 5/16-18 LRG FLG

NOTE: All component dimensions given in U.S. inches. 1 inch = 25.4 mm
IMPORTANT: Use only Original Equipment Manufacturer (O.E.M.) replacement parts. Failure to do so could be hazardous, damage your snow thrower and void your warranty.

REPAIR PARTS

CONTROL PANEL / DISCHARGE CHUTE

SNOW THROWER - MODEL NO. ST224 (96193009604), PRODUCT NO. 961 93 00-96

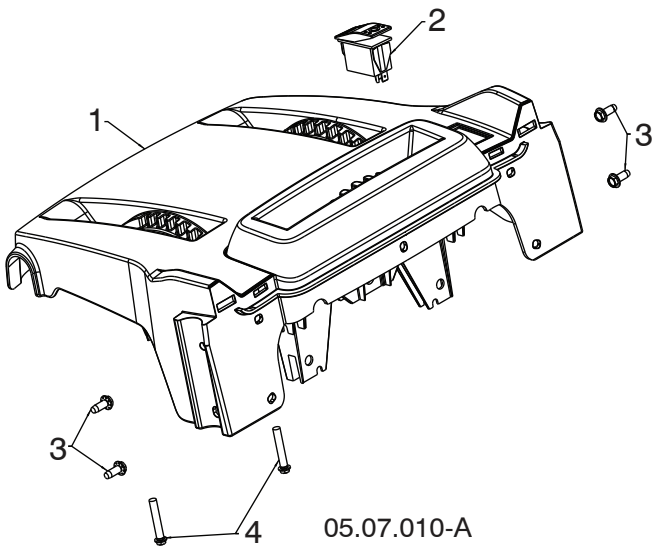

KEY NO.	PART NO.	DESCRIPTION
1	581 13 12-04	CONSOLE BASE MULTICONT GRAY-MS498
2	585 80 50-01	SWITCH GRIP HEATED BLACK
3	817 06 04-10	SCREW TA SEMI GIMLE 1/4-20 X .62
4	581 32 95-01	SCREW HEX WASHER HI-LO 13-16 X 1.50

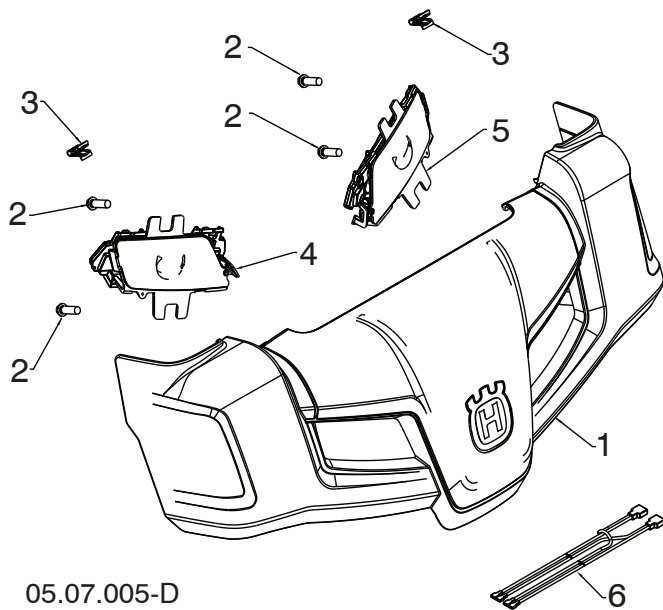

KEY NO.	PART NO.	DESCRIPTION
1	581 12 79-01	HUSQVARNA CONSOLE COVER ASM
2	532 19 41-89	SCREW HI-LO 13-16 X 5/8
3	581 92 87-01	CLIP PANEL
4	586 72 35-01	LIGHT ASM LED HUSQ RH
5	586 72 36-01	LIGHT ASM LED HUSQ LH
6	585 86 83-01	WIRE HARNESS LIGHT JUMPER

NOTE: All component dimensions given in U.S. inches. 1 inch = 25.4 mm
IMPORTANT: Use only Original Equipment Manufacturer (O.E.M.) replacement parts. Failure to do so could be hazardous, damage your snow thrower and void your warranty.

REPAIR PARTS

CONTROL PANEL / DISCHARGE CHUTE

SNOW THROWER - MODEL NO. ST224 (96193009604), PRODUCT NO. 961 93 00-96

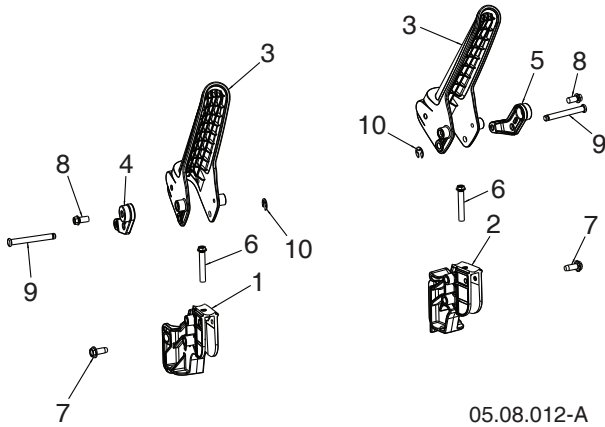

KEY NO.	PART NO.	DESCRIPTION
1	587 73 96-01	PIVOT, HANDLE LEVER - LHS
2	587 73 96-02	PIVOT, HANDLE LEVER - RHS
3	587 46 30-01	LEVER, CONTROL
4	587 73 97-01	LEVER, CABLE ARM - LHS
5	587 73 97-02	LEVER, CABLE ARM - RHS
6	581 32 95-01	SCREW HI-LO 13-16 X 1.50
7	817 06 04-10	SCREW 1/4-20 X .625
8	817 41 13-08	SCREW HI-LW 13-16 X .500
9	588 14 77-01	PIN, GROOVED
10	812 00 00-14	E-RING

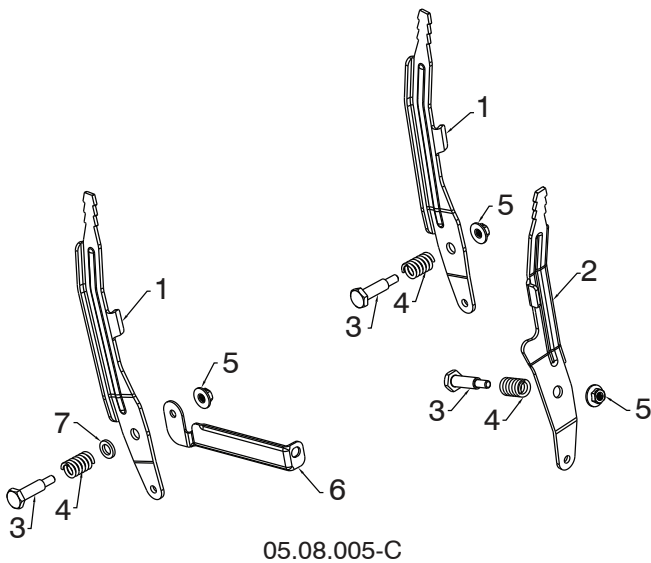

KEY NO.	PART NO.	DESCRIPTION
1	581 12 39-02	LEVER CONTROL SPEED/DEFL
2	581 24 16-02	LEVER CONTROL CHUTE ROT
3	581 32 97-01	BOLT SHOULDER 1/4-20
4	581 32 96-01	SPRING COMPRESSION
5	586 66 89-01	NUT FL LOCK 1/4-20
6	584 46 84-02	BRACE SUPPORT SPEED
7	587 03 13-01	WASHER .625 X .375 X .094 NYLON 6/6

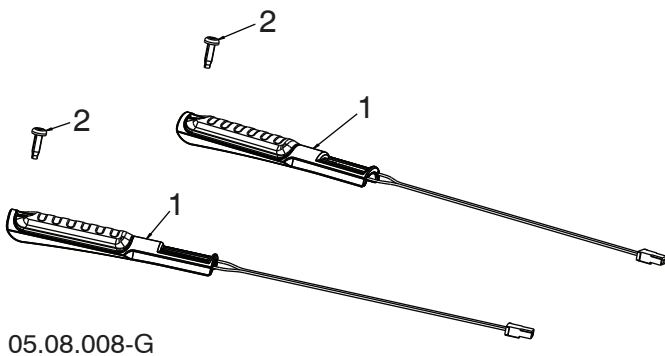

KEY NO.	PART NO.	DESCRIPTION
1	590 49 36-01	GRIP, HEATED, DSST SHO
2	532 44 22-50	SCREW PAN HD TORX 1/4-20 X .75

NOTE: All component dimensions given in U.S. inches. 1 inch = 25.4 mm
IMPORTANT: Use only Original Equipment Manufacturer (O.E.M.) replacement parts. Failure to do so could be hazardous, damage your snow thrower and void your warranty.

REPAIR PARTS

CONTROL PANEL / DISCHARGE CHUTE

SNOW THROWER - MODEL NO. **ST224** (96193009604), PRODUCT NO. 961 93 00-96

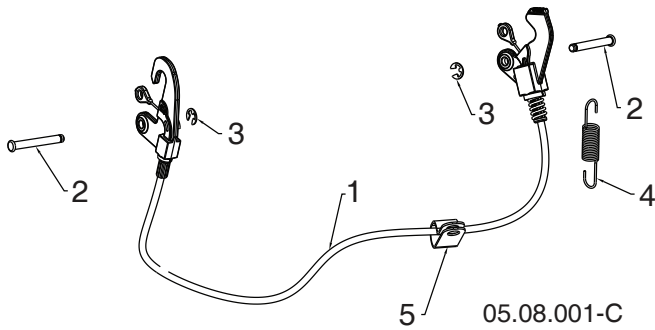

KEY NO.	PART NO.	DESCRIPTION
1	587 33 25-02	CABLE INTERLOCK
2	532 43 17-62	PIN GROOVED
3	812 00 00-14	E-RING
4	581 15 12-01	SPRING RETURN
5	532 19 79-91	CLIP CABLE BLACK

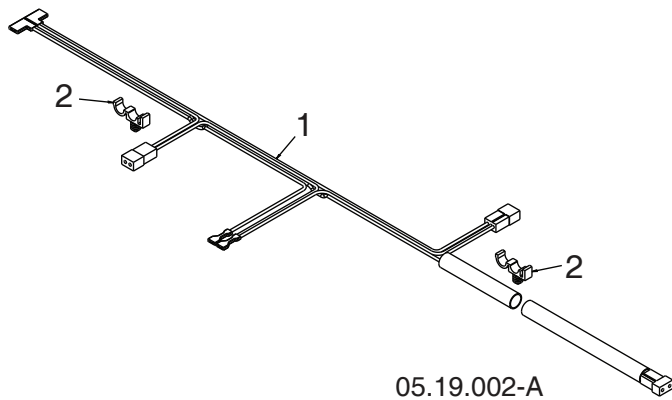

KEY NO.	PART NO.	DESCRIPTION
1	587 53 57-01	HARNESS WIRE LIGHTS & GRIPS
2	532 14 50-06	WIRE RETAINER

NOTE: All component dimensions given in U.S. inches. 1 inch = 25.4 mm
IMPORTANT: Use only Original Equipment Manufacturer (O.E.M.) replacement parts.
 Failure to do so could be hazardous, damage your snow thrower and void your warranty.

REPAIR PARTS

CONTROL PANEL / DISCHARGE CHUTE

SNOW THROWER - MODEL NO. ST224 (96193009604), PRODUCT NO. 961 93 00-96

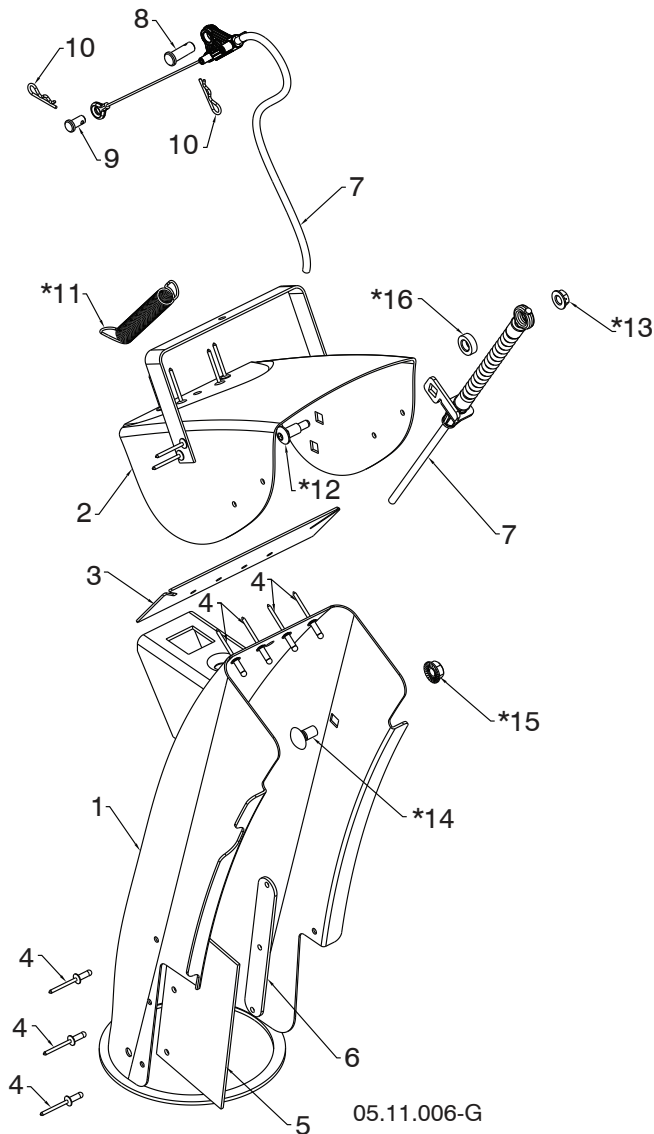

KEY NO.	PART NO.	DESCRIPTION
1	588 07 78-02	CHUTE WELDMENT ASSEMBLY (INCLUDES 1-6)
2	-----	RIVETED DEFLECTOR ASSEMBLY
3	-----	DEFLECTOR SEAL
4	-----	POP RIVET
5	-----	CHUTE SNOW SHIELD
6	-----	SHIELD STRAP RETAINER
7	590 58 70-01	CONTROL CHUTE DEFLECTOR BOWDEN
8	581 32 94-01	PIN CLEVIS 5/16 X .875
9	585 80 83-01	PIN CLEVIS 1/4 X .312
10	532 42 33-03	HAIRPIN RETAINER
*11	532 18 45-05	DEFLECTOR SPRING
*12	501 41 73-01	CARRIAGE BOLT 1/4-20 X .544
*13	585 69 14-01	NUT 1/4-20
*14	585 83 20-01	CARRIAGE BOLT 3/8-16 X .625
*15	873 97 05-00	NUT 5/16-18
*16	501 41 74-01	WASHER .362 X .625 X .205 NYLON

NOTE: ALL ITEMS MARKED WITH AN * ARE PROVIDED IN THE BAG OF ITEMS SHIPPED LOOSE WITH PRODUCT.

NOTE: All component dimensions given in U.S. inches. 1 inch = 25.4 mm
IMPORTANT: Use only Original Equipment Manufacturer (O.E.M.) replacement parts. Failure to do so could be hazardous, damage your snow thrower and void your warranty.

REPAIR PARTS

CONTROL PANEL / DISCHARGE CHUTE

SNOW THROWER - MODEL NO. ST224 (96193009604), PRODUCT NO. 961 93 00-96

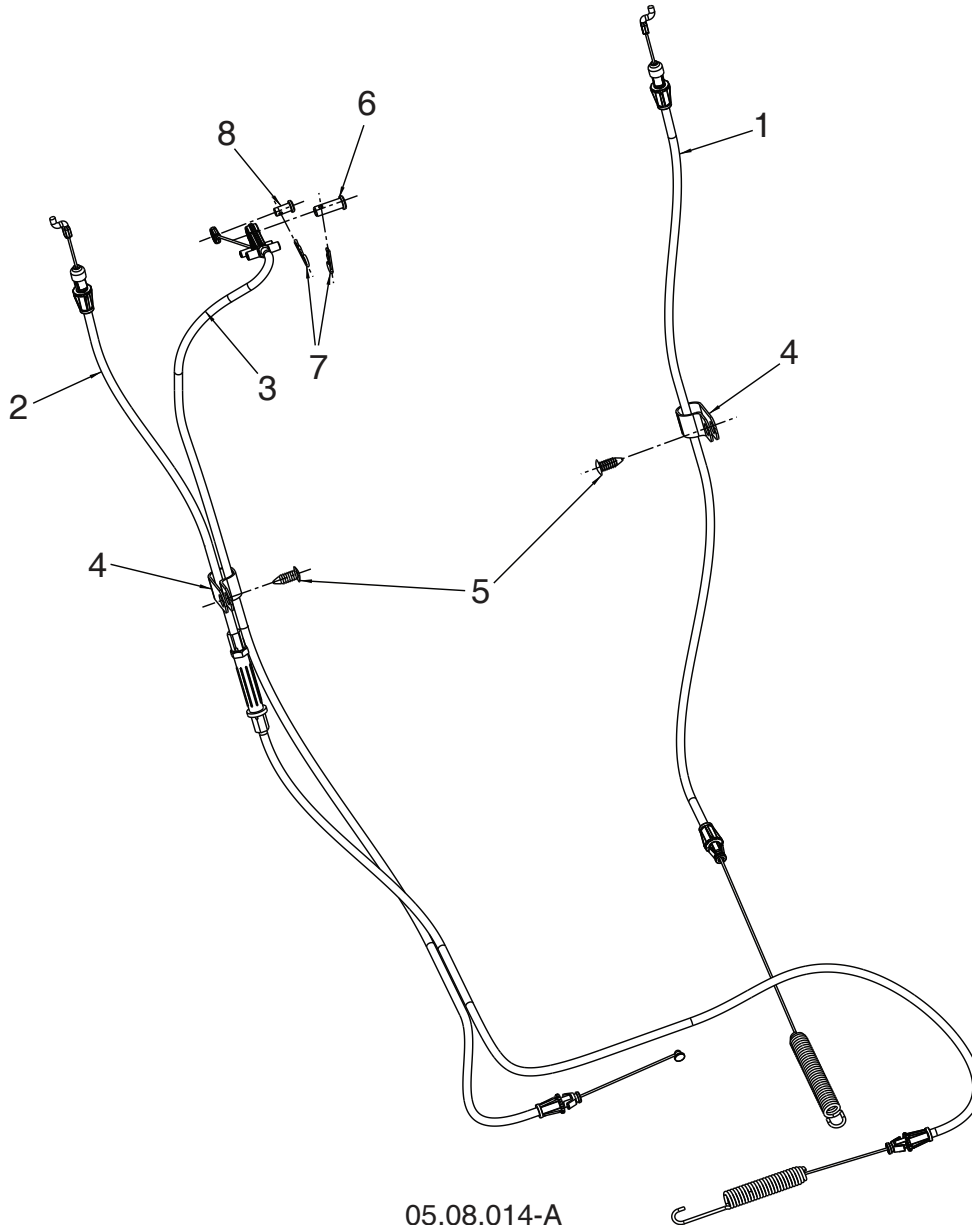

05.08.014-A

KEY NO.	PART NO.	DESCRIPTION
1	582 51 90-02	CABLE CONTROL DRIVE
2	588 11 38-02	CABLE CONTROL AUGER
3	588 12 23-01	CABLE CONTROL SPEED
4	532 19 79-91	CLIP CABLE
5	532 42 81-24	FASTENER PUSH .250
6	581 32 94-01	PIN CLEVIS 5/16
7	532 42 33-03	HAIRPIN
8	585 80 83-01	PIN CLEVIS 1/4

NOTE: All component dimensions given in U.S. inches. 1 inch = 25.4 mm
IMPORTANT: Use only Original Equipment Manufacturer (O.E.M.) replacement parts. Failure to do so could be hazardous, damage your snow thrower and void your warranty.

REPAIR PARTS

CONTROL PANEL / DISCHARGE CHUTE

SNOW THROWER - MODEL NO. **ST224** (96193009604), PRODUCT NO. 961 93 00-96

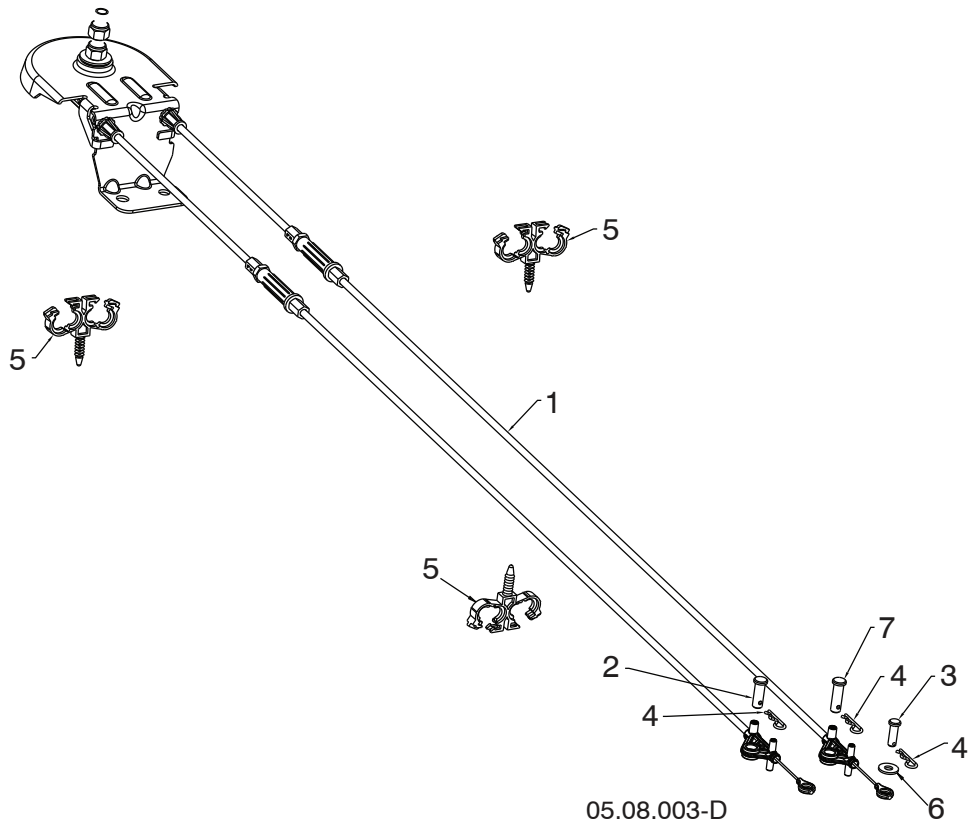

KEY NO.	PART NO.	DESCRIPTION
1	581 68 03-01	CABLE ROTATOR ASM
2	581 32 94-01	PIN CLEVIS 5/16 X 7/8
3	877 10 08-12	PIN CLEVIS 1/4 X 3/4
4	532 42 33-03	HAIRPIN SOFT ZINC
5	584 65 22-01	CLIP CONDUIT DOUBLE
6	586 68 21-01	WASHER
7	587 13 08-01	PIN CLEVIS 5/16 X 1

NOTE: All component dimensions given in U.S. inches. 1 inch = 25.4 mm
IMPORTANT: Use only Original Equipment Manufacturer (O.E.M.) replacement parts. Failure to do so could be hazardous, damage your snow thrower and void your warranty.

REPAIR PARTS

HANDLES

SNOW THROWER - MODEL NO. **ST224** (96193009604), PRODUCT NO. 961 93 00-96

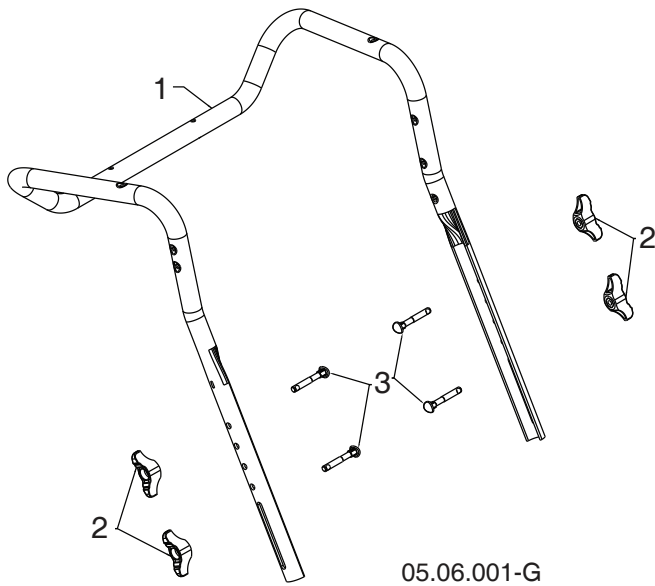

KEY NO.	PART NO.	DESCRIPTION
1	588 16 08-03	UPPER HANDLE
2	532 19 19-38	HANDLE KNOB STD BLACK
3	588 05 99-01	SCREW 5/16-18 X 2.25 CONCAVE HEAD WITH PATCH

05.06.001-G

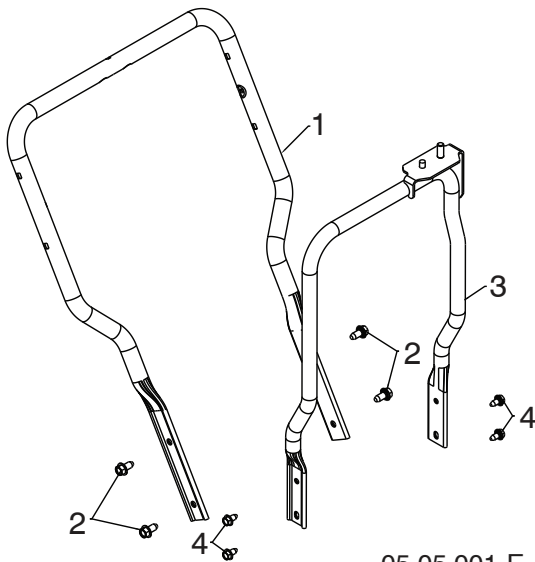

KEY NO.	PART NO.	DESCRIPTION
1	588 67 21-03	LOWER HANDLE
2	817 00 06-12	SCREW HEX WASH HD 3/8-16 X .75
3	581 62 20-02	CHUTE ROTATOR SUPPORT ASM
4	817 00 05-10	BOLT HEX 5/16-18

05.05.001-E

NOTE: All component dimensions given in U.S. inches. 1 inch = 25.4 mm
IMPORTANT: Use only Original Equipment Manufacturer (O.E.M.) replacement parts.
 Failure to do so could be hazardous, damage your snow thrower and void your warranty.

REPAIR PARTS

DRIVE

SNOW THROWER - MODEL NO. **ST224** (96193009604), PRODUCT NO. 961 93 00-96

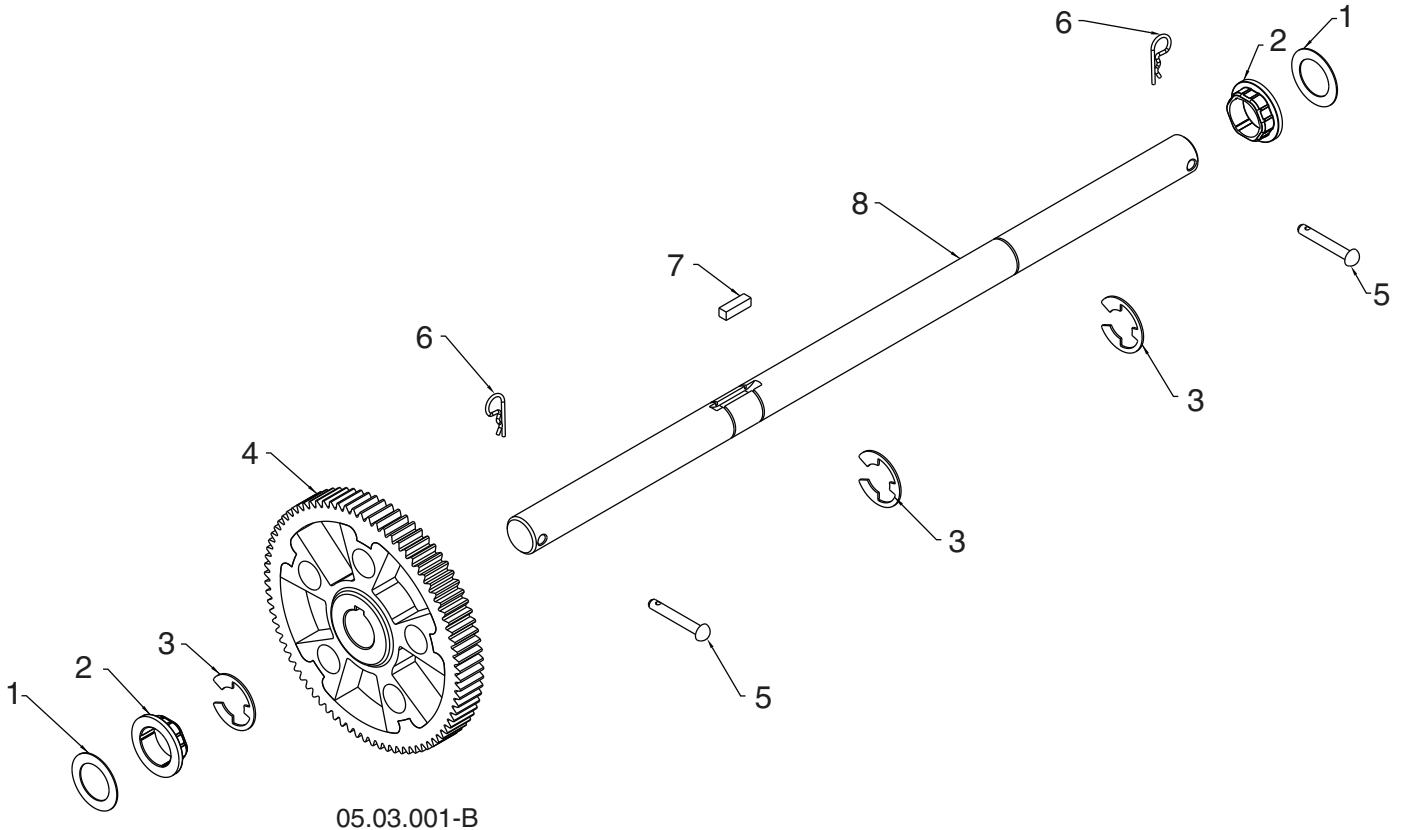

KEY NO.	PART NO.	DESCRIPTION
1	532 44 49-49	WASHER 1.00
2	587 97 89-01	HEX BUSHING 1 SHAFT
3	812 00 00-53	RETAINING RING
4	588 51 87-02	GEAR 80T DRIVEN
5	532 17 12-71	RIVET RD HD DRILLED 1/4 DIA
6	532 12 47-88	RETAINER SPRING
7	532 18 92-82	SQUARE KEY 1/4 X .875
8	581 12 20-01	AXLE SHAFT

NOTE: All component dimensions given in U.S. inches. 1 inch = 25.4 mm
IMPORTANT: Use only Original Equipment Manufacturer (O.E.M.) replacement parts. Failure to do so could be hazardous, damage your snow thrower and void your warranty.

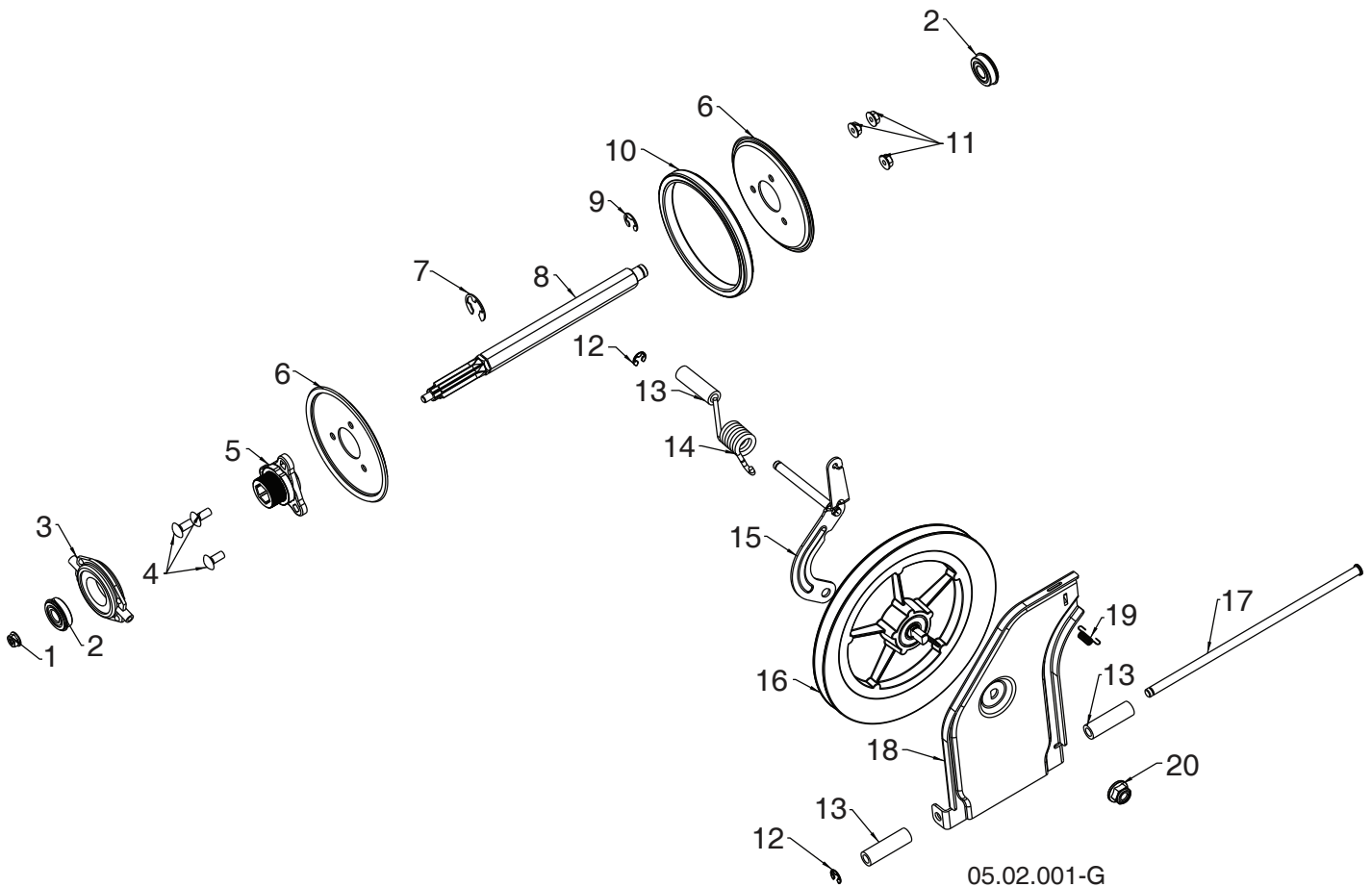

NOTE: All component dimensions given in U.S. inches. 1 inch = 25.4 mm
IMPORTANT: Use only Original Equipment Manufacturer (O.E.M.) replacement parts.
Failure to do so could be hazardous, damage your snow thrower and void your warranty.

REPAIR PARTS**DRIVE****SNOW THROWER - MODEL NO. ST224 (96193009604), PRODUCT NO. 961 93 00-96**

KEY NO.	PART NO.	DESCRIPTION
1	585 69 15-01	NUT HEX FLANGE LK 5/16-18
2	580 75 62-01	BEARING 9/16 I.D. 1622-2RSNR
3	532 17 53-44	TRUNNION BEARING ASM
4	872 11 05-06	BOLT CARRIAGE 5/16-18 X .75 GR 5
5	581 09 09-01	HUB RUBBER WHEEL
6	581 09 10-02	RUBBER WHEEL PLATE
7	812 00 00-22	E-RING
8	581 12 19-01	SHAFT 7 TOOTH REDUCTION
9	580 75 61-02	RETAINING RING 1622-2RSNR
10	581 09 11-01	RUBBER WHEEL RING
11	532 75 11-53	NUT HEX FLANGE LK 5/16-18
12	812 00 00-07	E-RING RETAINER 375
13	581 73 27-01	DRIVE SPACER
14	581 31 53-01	DRIVE TORSION SPRING
15	587 19 34-03	YOKE BRACKET ASSEMBLY
16	581 32 84-01	FRICTION PULLEY DISC COMBO
17	581 12 30-01	ROD TIP PLATE
18	587 70 34-02	FRICTION SWING PLATE PULL
19	532 19 38-85	LATCH SPRING
20	521 99 11-01	NUT HEX FLANGE LK 1/2-13

NOTE: All component dimensions given in U.S. inches. 1 inch = 25.4 mm

IMPORTANT: Use only Original Equipment Manufacturer (O.E.M.) replacement parts. Failure to do so could be hazardous, damage your snow thrower and void your warranty.

REPAIR PARTS

CHASSIS / ENGINE / PULLEYS

SNOW THROWER - MODEL NO. **ST224** (96193009604), PRODUCT NO. 961 93 00-96

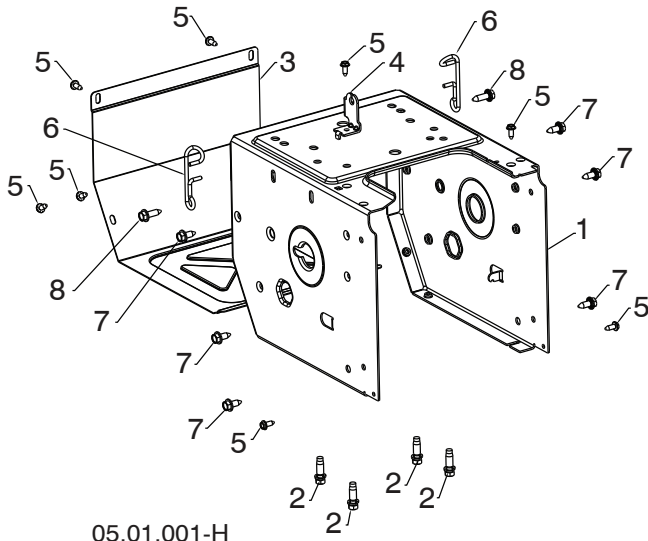

05.01.001-H

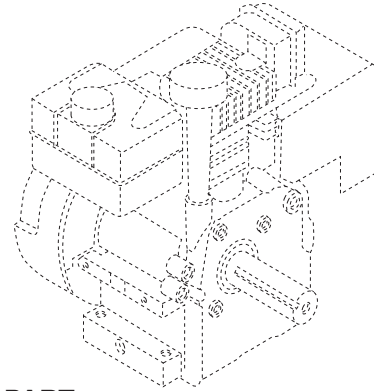

KEY NO.	PART NO.	DESCRIPTION
--	580 42 60-07	COMPLETE LCT ENGINE PW2HK18650178E
1	580 83 94-05	FRAME
2	532 15 04-06	ENGINE BOLT 3/8-16 X 1.280 DOGPOINT
3	580 83 95-07	FRAME COVER
4	501 06 04-03	SHIFTER BRACKET
5	582 90 69-01	SCREW HEX WASHER 1/4-20 X .625
6	588 95 45-01	WIREFORM SUPPORT CABLE
7	532 42 88-67	BOLT HEXHD WASHER 5/16-18 X .750
8	585 21 75-01	BOLT HEXHD WASHER 5/16-18 X 1.000

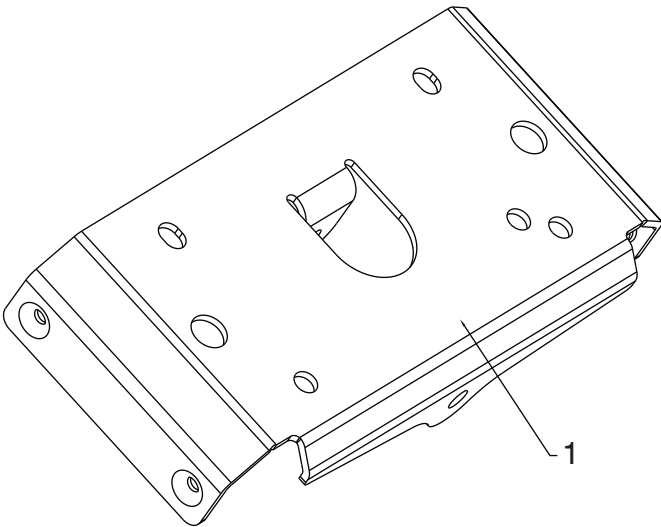

05.01.002-A

KEY NO.	PART NO.	DESCRIPTION
1	583 94 05-02	SMALL MOUNTING PLATE

NOTE: All component dimensions given in U.S. inches. 1 inch = 25.4 mm
IMPORTANT: Use only Original Equipment Manufacturer (O.E.M.) replacement parts. Failure to do so could be hazardous, damage your snow thrower and void your warranty.

REPAIR PARTS

CHASSIS / ENGINE / PULLEYS

SNOW THROWER - MODEL NO. **ST224** (96193009604), PRODUCT NO. 961 93 00-96

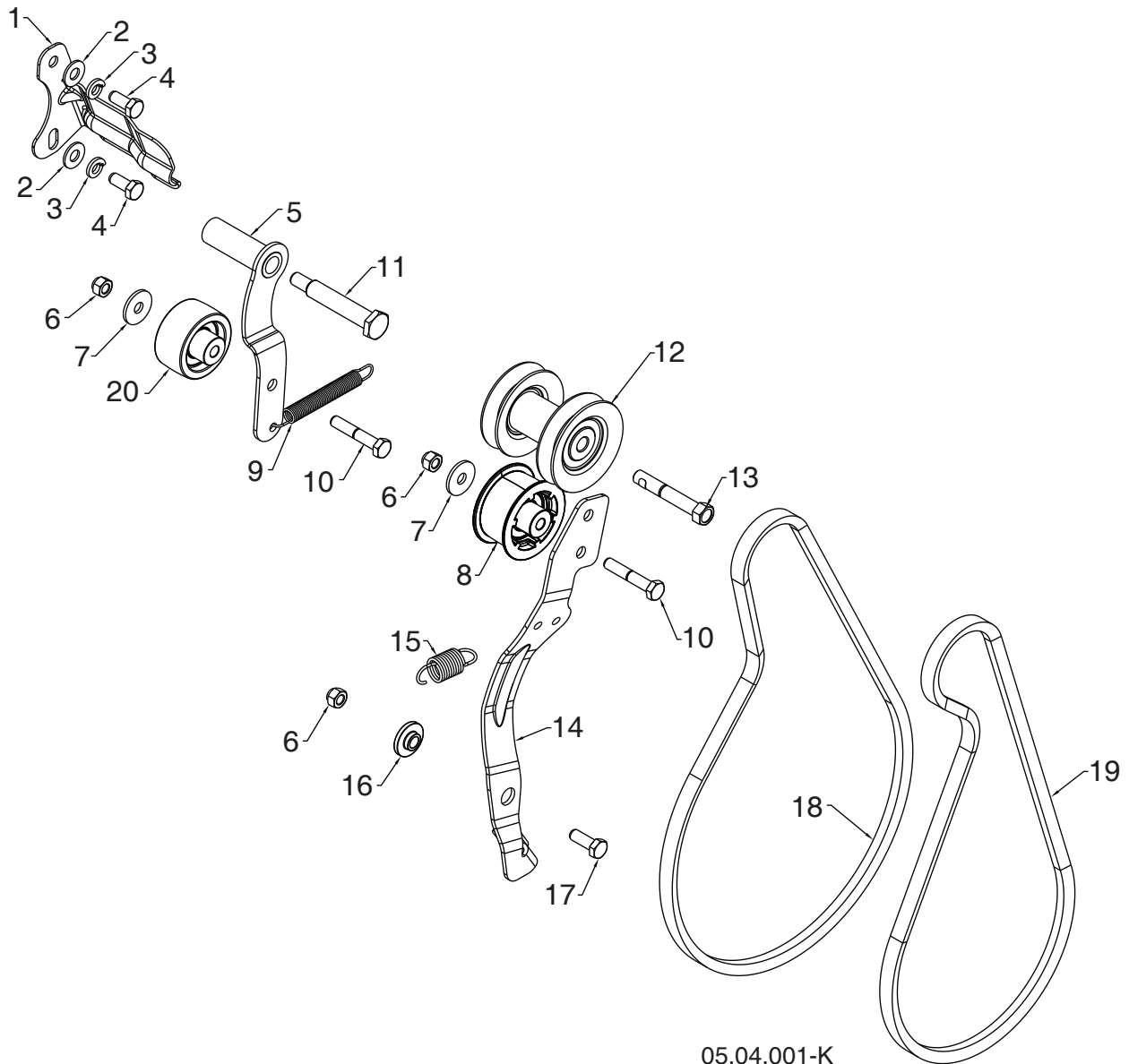

05.04.001-K

KEY NO.	PART NO.	DESCRIPTION	KEY NO.	PART NO.	DESCRIPTION
1	588 49 28-02	BELT KEEPER BRACKET	11	581 41 38-01	SHOULDER BOLT 5/16-24 X 2.15
2	819 11 12-16	WASHER 11/32 X 3/4 X 16 GA	12	587 89 37-03	PULLEY ASM ENGINE
3	810 04 05-00	LOCKWASHER 5/16 SPLIT HVY	13	582 38 84-01	BOLT HEXHD 3/8-24 X 2.375
4	874 61 05-12	CAPSCREW HEXHD 5/16-24 X .75 GR 5	14	580 83 11-06	ARM IDLER
5	581 33 82-03	IDLER ARM DRIVE WELDMENT	15	587 03 12-01	RETURN SPRING IDLER ARM
6	873 80 05-00	NUT NYLOCK 5/16-18	16	587 34 37-01	BUSHING IDLER PIVOT
7	532 05 92-89	WASHER FLAT .328 X 1.00 X .097	17	874 76 05-14	BOLT HEXHD 5/16-18 X .875
8	581 14 14-01	IDLER PULLEY 2.0 W/SPACER	18	584 21 61-02	DRIVE BELT 4L X 38.2
9	580 75 30-01	RETURN SPRING IDLER ARM DRIVE	19	501 81 82-01	IMPELLER BELT
10	874 76 05-28	BOLT HEXHD 5/16-18 X 1.75	20	586 88 02-01	IDLER PULLEY 2.0 FLANGELESS W/SPACER

NOTE: All component dimensions given in U.S. inches. 1 inch = 25.4 mm

IMPORTANT: Use only Original Equipment Manufacturer (O.E.M.) replacement parts. Failure to do so could be hazardous, damage your snow thrower and void your warranty.

REPAIR PARTS

CHASSIS / ENGINE / PULLEYS

SNOW THROWER - MODEL NO. **ST224** (96193009604), PRODUCT NO. 961 93 00-96

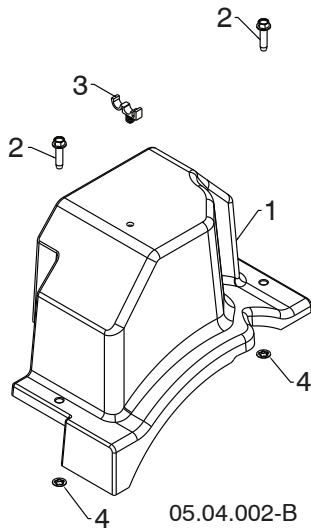

KEY NO.	PART NO.	DESCRIPTION
1	587 10 54-01	BELT COVER BLACK ASSEMBLY (INCLUDES 2 & 4)
2	-----	BOLT HEX WSH THDRL 1/4-20 X 1
3	532 14 50-06	CABLE GUIDE
4	-----	PALNUT 1/4 IN

NOTE: All component dimensions given in U.S. inches. 1 inch = 25.4 mm
IMPORTANT: Use only Original Equipment Manufacturer (O.E.M.) replacement parts. Failure to do so could be hazardous, damage your snow thrower and void your warranty.

REPAIR PARTS

WHEELS

SNOW THROWER - MODEL NO. **ST224** (96193009604), PRODUCT NO. 961 93 00-96

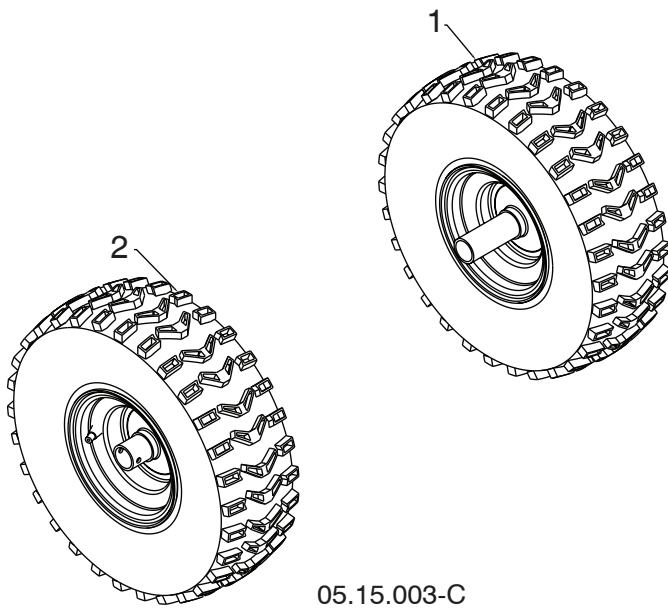

KEY NO.	PART NO.	DESCRIPTION
1	586 71 04-01	WHEEL 15X5.00 NPS LH 1.00 K478
2	586 71 03-01	WHEEL 15X5.00 NPS RH 1.00 K478

NOTE: All component dimensions given in U.S. inches. 1 inch = 25.4 mm
IMPORTANT: Use only Original Equipment Manufacturer (O.E.M.) replacement parts.
Failure to do so could be hazardous, damage your snow thrower and void your warranty.

REPAIR PARTS

BAG OF PARTS

SNOW THROWER - MODEL NO. **ST224** (96193009604), PRODUCT NO. 961 93 00-96

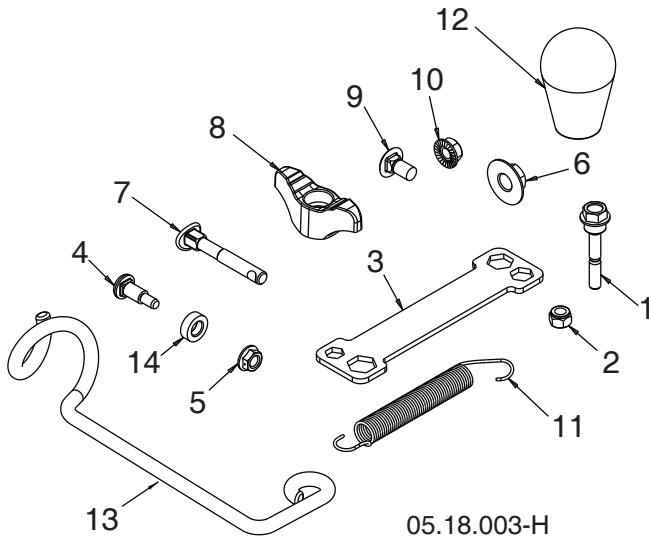

KEY NO.	PART NO.	DESCRIPTION
1	588 07 75-01	BOLT 1/4-20 X 1.81
2	873 80 04-00	NUT NYLOCK 1/4-20
3	532 42 91-12	WRENCH
4	501 41 73-01	BOLT SHOULDER
5	585 69 1401	NUT HEX FL 1/4-20 CTR
6	585 69 10-01	NUT NYLOCK 3/8-16
7	588 05 99-01	BOLT 5/16-18 X 2.25 CONCAVE
8	532 19 19-38	KNOB 5/16-18 TWO-WING
9	585 83 20-01	BOLT 5/16-18 X .625
10	873 97 05-00	NUT SERR FL LOCK 5/16-18
11	532 18 45-05	SPRING DEFLECT CHUTE
12	581 69 75-01	KNOB SOFT TOUCH SLOTTED
13	581 89 73-01	SUPPORT ROTATION CABLE
14	501 41 74-01	WASHER NYLON
NI	588 07 76-03	KIT REPLACEMENT BAG OF PARTS

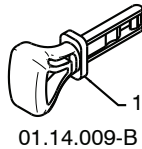

KEY NO.	PART NO.	DESCRIPTION
1	532 44 30-59	SAFETY IGNITION KEY KIT

NOTE: All component dimensions given in U.S. inches. 1 inch = 25.4 mm
IMPORTANT: Use only Original Equipment Manufacturer (O.E.M.) replacement parts.
 Failure to do so could be hazardous, damage your snow thrower and void your warranty.



1



3



2



4

KEY NO.	PART NO.	DESCRIPTION
1	532 18 40-45	DECAL AUGER
2	590 81 22-01	DECAL CHUTE
3	532 19 96-83	DECAL AUGER SAFETY
4	532 18 40-28	DECAL BELT GUIDE

05.16.001-A

NOTE: All component dimensions given in U.S. inches. 1 inch = 25.4 mm
IMPORTANT: Use only Original Equipment Manufacturer (O.E.M.) replacement parts. Failure to do so could be hazardous, damage your snow thrower and void your warranty.

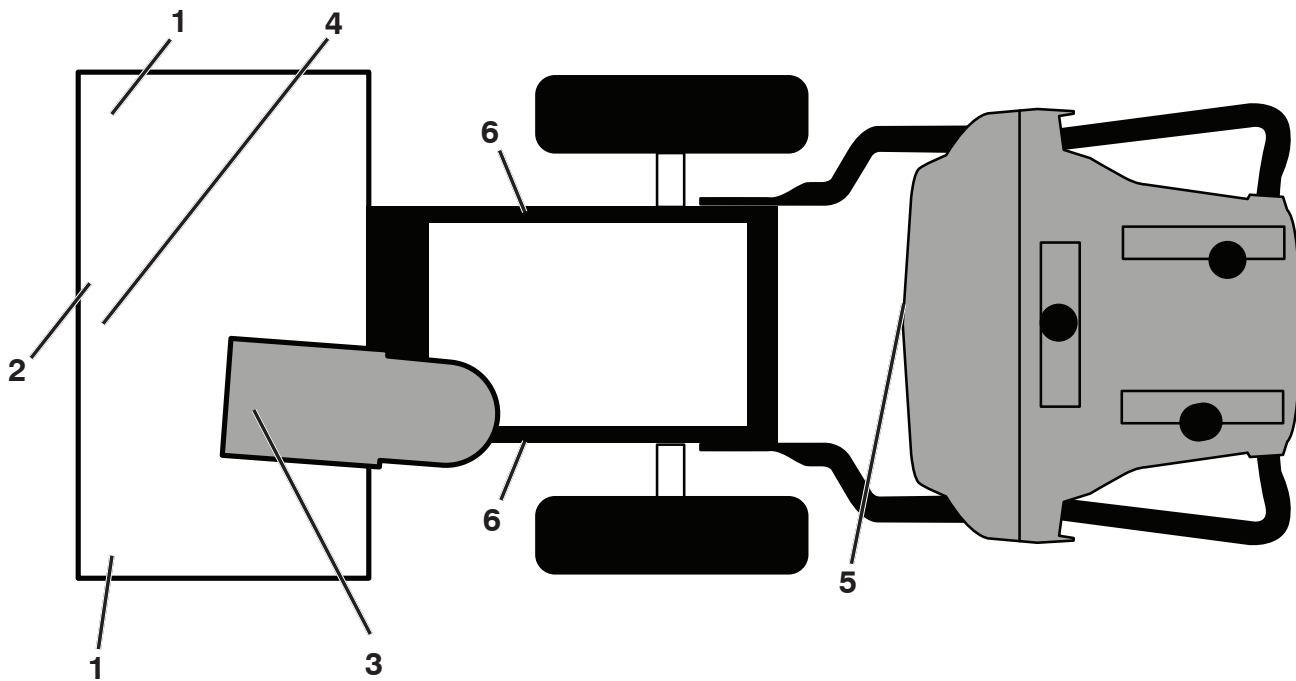

KEY NO.	PART NO.	DESCRIPTION
1	532 19 96-83	DECAL, DANGER
2	588 59 71-01	DECAL, AUGER HOUSING
3	590 81 22-01	DECAL, DANGER, DEFLECTOR
4	532 18 40-45	DECAL, DANGER
5	532 42 86-77	DECAL, CONSOLE "H"
6	532 18 40-28	DECAL, INSTRUCTION
--	115 73 40-27	OPERATOR'S MANUAL, ENGLISH
--	115 73 40-31	OPERATOR'S MANUAL, FRENCH
--	115 73 40-46	OPERATOR'S MANUAL, SPANISH

NOTE: All component dimensions given in U.S. inches. 1 inch = 25.4 mm
IMPORTANT: Use only Original Equipment Manufacturer (O.E.M.) replacement parts. Failure to do so could be hazardous, damage your snow thrower and void your warranty.

ENGINE, LCT

COMPLETE ENGINE-580426007

GEN II 136/179/208/254cc Snow Engines

9999 Options

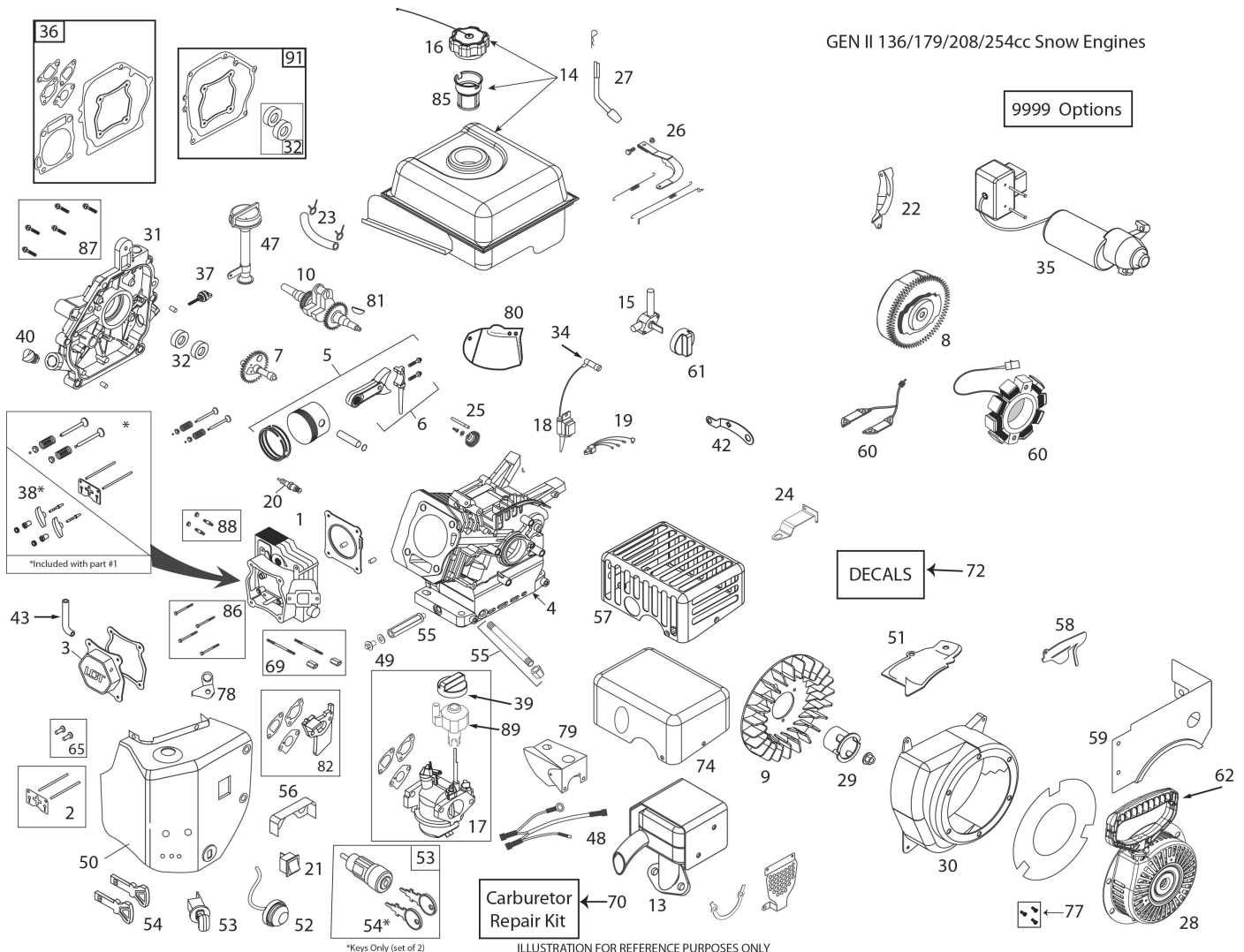

*Keys Only (set of 2)

ILLUSTRATION FOR REFERENCE PURPOSES ONLY

KEY PART NO.	NO.	DESCRIPTION
1	532 42 05-78	CYLINDER HEAD ASSEMBLY - 208CC (INCL. GASKET)
2	532 42 05-79	PUSH ROD & PLATE KIT (208CC) (INCL. VALVE COVER GSKT)
3	532 42 05-80	VALVE COVER (208CC) (INCL. GASKET)
4	N/A	N/A
5	532 42 05-82	PISTON & ROD ASSEMBLY (208CC)
6	532 42 05-83	CONNECTING ROD ASSEMBLY (208CC)
7	532 42 05-84	CAMSHAFT - MCR (208CC)
8	532 44 38-92	FLYWHEEL - ELECTRIC START (6-CHARGING MAGNETS) (208CC)
9	532 42 05-86	COOLING FAN - FLYWHEEL (PLASTIC - 208CC)
10	532 44 66-42	CRANKSHAFT (#18 KEYED 208CC SNOW)

KEY PART NO.	NO.	DESCRIPTION
13	587 73 78-01	MUFFLER ASSEMBLY - 208CC QUIET MUFFLER
14	532 43 65-64	FUEL TANK (208CC-SNOW) (2.7L BLACK W/PLASTIC CAP - GEN II)
15	532 42 92-34	FUEL TANK ON/OFF VALVE (PETCOCK) - GEN II SNOW
16	532 42 49-42	FUEL TANK CAP - BLACK CLICK STYLE (VENTED)
17	587 14 79-01	CARBURETOR SNOW 208CC IDLEDOWN
18	532 44 38-94	IGNITION COIL (CDI) (208CC)(HI-TEMP)
19	N/A	N/A
20	532 42 49-39	SPARK PLUG
21	532 42 49-57	ON/OFF SWITCH - ROCKER
22	532 42 49-75	SHIELD - FLYWHEEL - ELECTRIC START - SNOW

ENGINE, LCT**COMPLETE ENGINE-580426007**

KEY NO.	PART NO.	DESCRIPTION	KEY NO.	PART NO.	DESCRIPTION
23	532 43 80-14	FUEL HOSE KIT (1/4' ID X 318MM - SS SNOW)	55	587 15 44-01	FRONT OIL DRAIN PIPE & NUT ASSY
24	532 42 92-59	SPEED CONTROL BRACKET (FIXED)	56	532 42 92-60	CARBURETOR VAPOR SHIELD - 208CC SNOW
25	532 42 96-46	GOVERNOR GEAR ASSEMBLY (136/208CC)	57	N/A	N/A
26	581 76 87-01	GOVERNOR ARM & LINK KIT (208CC SNOW - 3600 FIXED RPM)	58	532 42 49-60	SHIELD - GOVERNOR LINKAGE - 208CC SNOW
27	532 42 06-02	GOVERNOR ARM PADDLE	59	532 43 65-62	FUEL TANK SKIRT (208CC SNOW)
28	532 43 69-67	RECOIL STARTER ASSY(ROUND-BLACK)SNOW	60	532 44 38-93	CHARGING COIL (60-WATT AC) (208/254CC)
29	532 43 69-68	STARTER CUP (FOR ROUND STYLE STARTER) (208CC SNOW)	61	532 43 27-52	FUEL CONTROL KNOB (GEN II SNOW - RED)
30	581 19 20-01	BLOWER HOUSING - BLACK ELECTRIC START W/INTEGRATED BAFFLE	62	532 42 49-68	STARTER GRIP-SNOW
31	581 00 73-01	CRANKCASE COVER ASSY (PRESS-IN TYPE HOFT)(INCL. GASKET)	65	581 37 28-01	TAPPET KIT (208/254CC)(SET OF 2)
32	532 42 95-99	OIL SEAL KIT (2 PCS FOR 3/4-INCH CRANKSHAFT)	69	532 42 49-51	CARBURETOR STUDS & COUPLING KIT-SNOW
34	532 43 69-66	SPARK PLUG BOOT - WITH METAL SHIELD (SNOW)	70	580 35 36-01	CARBURETOR REPAIR KIT (136/208/254CC)
35	532 43 64-66	120V ELECTRIC STARTER (208/254CC GEN LL) (SIDE MOUNT)	72	532 43 56-47	STORMFORCE LABEL KIT-208CC SNOW
36	532 42 96-01	ENGINE GASKET KIT (208CC)	74	587 82 11-01	MUFFLER GUARD 208-254CC (CE COMPLIANT)
37	532 42 09-61	SMALL BLACK OIL DIPSTICK (PLASTIC)	77	532 43 26-88	RECOIL BOLT KIT (3 BOLTS PER KIT)
38	532 42 96-91	ROCKER ARM KIT (208CC)(INCL. GASKET)	78	581 45 93-01	BREATHER TUBE BRACKET
39	532 42 92-24	CHOKE CONTROL KNOB (GEN II RED)	79	585 77 37-01	CARBURETOR COVER (136CC SNOW)
40	532 42 95-98	NON-REMOVABLE PLASTIC PLUG (136/208/254CC)	80	N/A	N/A
42	N/A	N/A	81	585 29 72-01	WOODRUFF FLYWHEEL KEYS (5-PACK) (5X6X18MM)(208/414CC)
43	580 35 34-01	BREATHER TUBE (136/208/254CC)	82	585 02 05-03	208CC/254CC CARBURETOR SPACER KIT
47	581 00 72-01	HIGH OIL-FILL TUBE/DIPSTICK (PRESS-IN TYPE)	85	586 32 56-01	FUEL TANK STRAINER
48	532 42 92-62	WIRE HARNESS (208CC SNOW)	86	586 32 73-01	CYLINDER HEAD BOLT KIT (4) (136-179-208-254CC)
49	532 43 54-95	OIL DRAIN PLUG W/WASHER (136/208/254CC)	87	586 32 69-01	CC COVER BOLT KIT (6) (179-208-254CC)
50	532 43 65-61	HEATER BOX KIT (GEN LL 208CC SNOW)	88	586 32 68-01	MUFFLER MTG STUD KIT (2)
51	532 43 71-19	SHIELD - CYLINDER	89	587 12 48-01	SPEED CONTROL KNOB (GREY)
52	532 42 49-49	PRIMER BULB WITH HOSE-SNOW	91	587 52 57-01	CRANKSHAFT GASKET KIT 179-208CC
53	532 42 49-54	SAFETY KEY SWITCH -SNOW (INCL. KEYS)	9999	586 32 62-01	HIGH ALTITUDE JET (>6,000 FEET)(208CC L10-1 CARBURETOR)
54	532 44 30-59	KEY SET - RED (2) (SNOW)	9999	579 80 64-01	BOLT KIT - BLWR HGS/HEATER BOX/TANK SKIRT
			9999	590 64 01-01	MUFFLER MANIFOLD GUARD

