

**ILLUSTRATED PARTS LIST**

**MODEL NUMBER ST 330 P**

**PRODUCT NUMBER 961 93 00-94**

**MFG. ID. NUMBER 96193009404**

# REPAIR PARTS

# AUGER HOUSING / IMPELLER ASSEMBLY

SNOW THROWER - MODEL NO. ST 330 P (96193009404), PRODUCT NO. 961 93 00-94

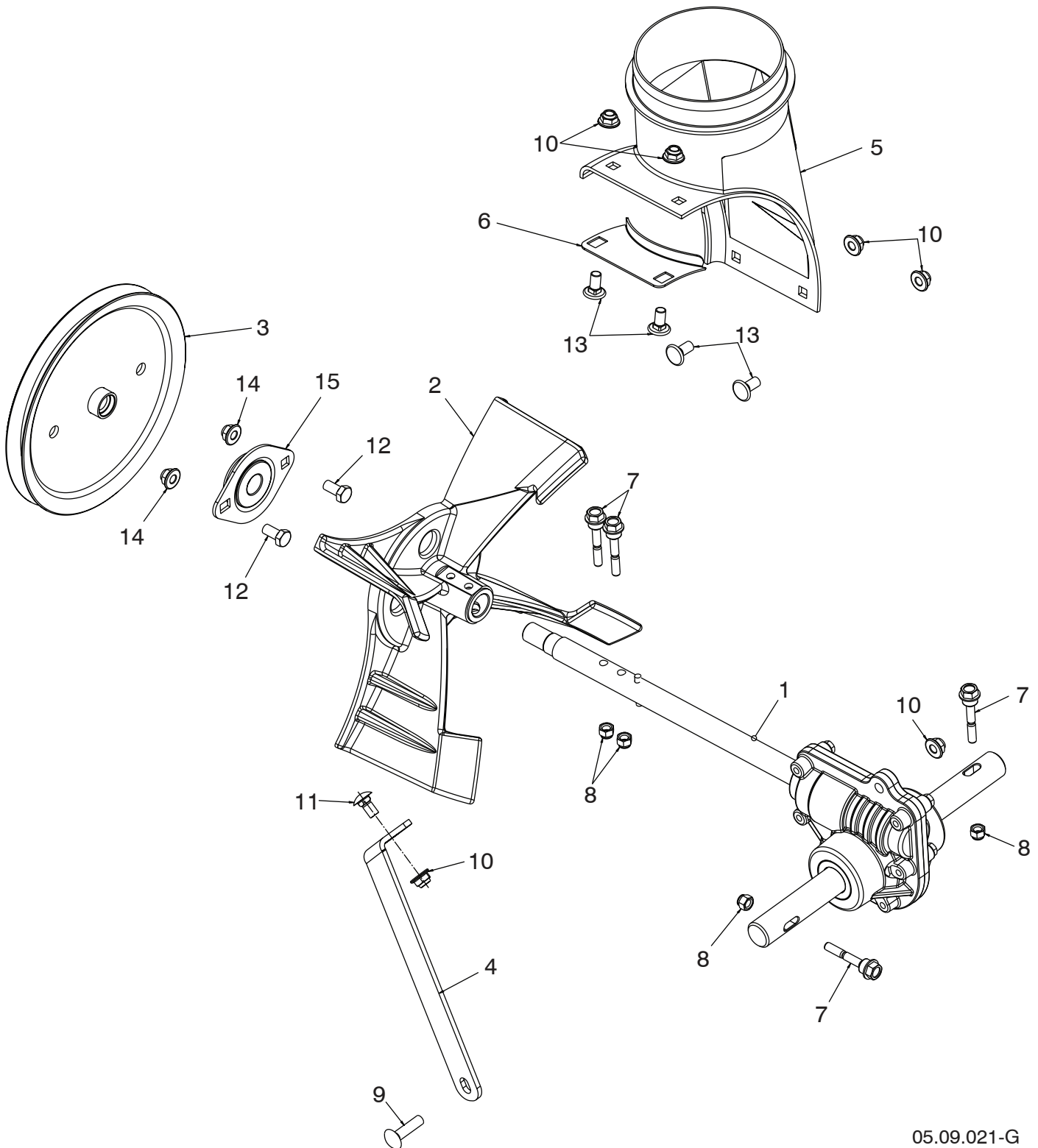

05.09.021-G

**NOTE:** All component dimensions given in U.S. inches. 1 inch = 25.4 mm  
**IMPORTANT:** Use only Original Equipment Manufacturer (O.E.M.) replacement parts. Failure to do so could be hazardous, damage your snow thrower and void your warranty.

**REPAIR PARTS****AUGER HOUSING / IMPELLER ASSEMBLY****SNOW THROWER - MODEL NO. ST 330 P (96193009404), PRODUCT NO. 961 93 00-94**

<b>KEY NO.</b>	<b>PART NO.</b>	<b>DESCRIPTION</b>
1	586 71 50-01	GEARBOX AUGER CAST IRON 5/8 THREAD
2	585 19 83-03	IMPELLER CAST IRON
3	586 71 54-01	PULLEY IMPELLER 7.9 – SCREW ON
4	585 10 90-04	SUPPORT GEARBOX GREY
5	585 05 69-01	CHUTE DISCHARGE BASE
6	532 18 40-95	BRACKET CORNER DISCHARGE BASE
7	588 07 75-01	BOLT SHEAR 1/4-20
8	873 80 04-00	NUT NYLOCK 1/4-20
9	872 11 05-10	BOLT CARRIAGE 5/16-18 X 1-1/4
10	585 69 13-01	NUT FLANGE NYLOCK 5/16-18 X 1-1/4
11	585 83 20-01	BOLT CARRIAGE 5/16-18 X 5/8 - BLK
12	532 16 31-83	SCREW HEX HEAD 5/16-18 X 5/8
13	585 69 12-01	BOLT CARRIAGE WAFER HEAD 5/16-18 X 5/8 - BLK
14	532 42 79-42	NUT FLANGE NYLOCK 5/16-18
15	532 18 89-09	BEARING FLANGE

**NOTE:** All component dimensions given in U.S. inches. 1 inch = 25.4 mm

**IMPORTANT:** Use only Original Equipment Manufacturer (O.E.M.) replacement parts. Failure to do so could be hazardous, damage your snow thrower and void your warranty.

# REPAIR PARTS

# AUGER HOUSING / IMPELLER ASSEMBLY

SNOW THROWER - MODEL NO. ST 330 P (96193009404), PRODUCT NO. 961 93 00-94

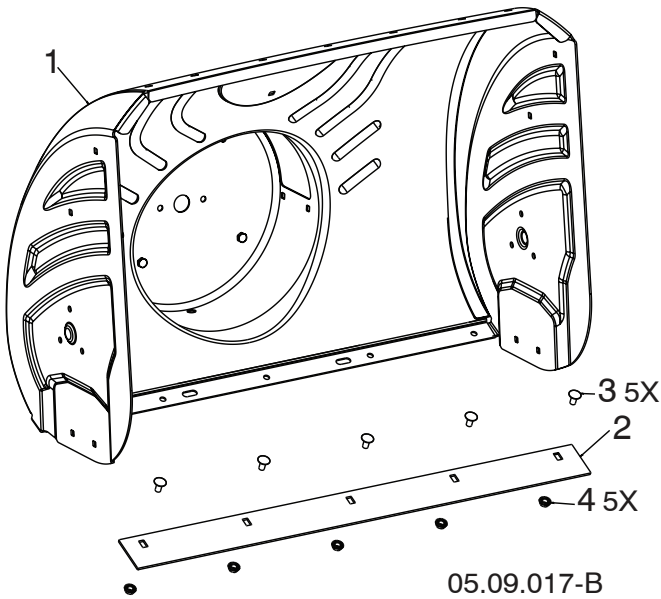

KEY NO.	PART NO.	DESCRIPTION
1	581 70 83-92	AUGER HOUSING 30 LS
2	585 04 85-02	SHAVE.PLATE 30 LS MS428
3	872 27 05-05	BOLT CARRIAGE 5/16-18 X .625
4	532 15 53-77	NUT 5/16-18 HEX TOP LOCK

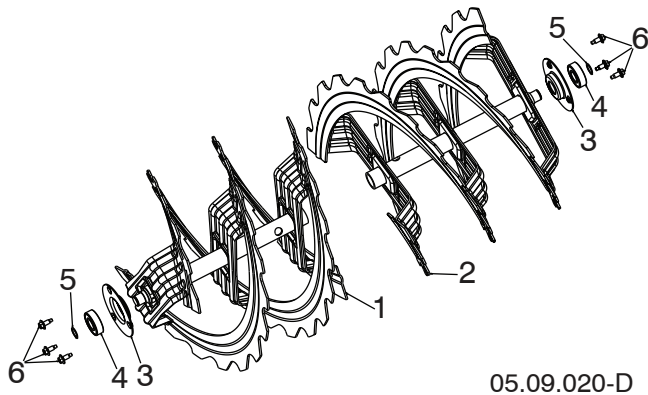

KEY NO.	PART NO.	DESCRIPTION
1	581 97 05-03	AUGER RIBBON 24 RH LS
2	581 97 06-03	AUGER RIBBON 24 LH LS
3	580 85 55-01	SUPPORT AUGER BEARING
4	532 43 76-22	BEARING IDLER 6203
5	812 00 00-28	RING RETAINING #5100-52
6	585 51 78-01	SCREW 1/4-20 X .65 W/DOG POINT

**NOTE:** All component dimensions given in U.S. inches. 1 inch = 25.4 mm  
**IMPORTANT:** Use only Original Equipment Manufacturer (O.E.M.) replacement parts. Failure to do so could be hazardous, damage your snow thrower and void your warranty.

**REPAIR PARTS**

**AUGER HOUSING / IMPELLER ASSEMBLY**

**SNOW THROWER - MODEL NO. ST 330 P (96193009404), PRODUCT NO. 961 93 00-94**

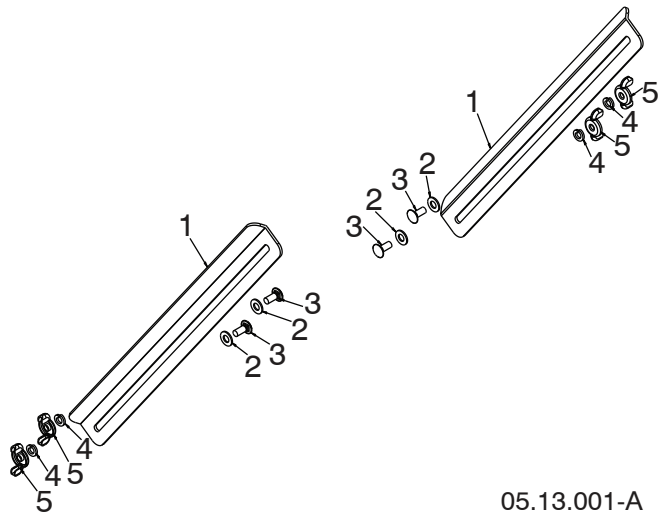

05.13.001-A

KEY NO.	PART NO.	DESCRIPTION
1	532 18 47-47	DRIFT BAR CUTTER
2	532 17 92-46	WASHER FRICTION NYLON
3	872 27 05-06	CARRIAGE BOLT 5/16-18 X .75 GR5
4	810 04 05-00	LOCKWASHER 5/16 SPLIT
5	532 12 86-38	WING NUT 5/16-18 ZINC

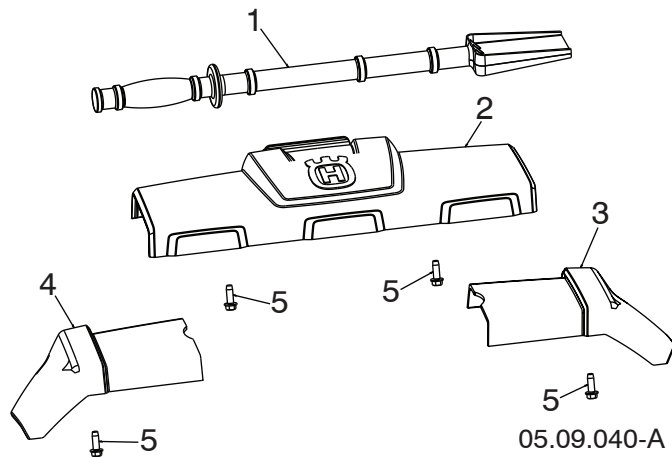

05.09.040-A

KEY NO.	PART NO.	DESCRIPTION
1	532 19 21-99	TOOL CLEANOUT
2	586 41 48-01	TRIM AUGER HOUSING FRONT ASM
3	586 33 03-02	TRIM AUGER HOUSING WING RH
4	586 33 04-02	TRIM AUGER HOUSING WING LH
5	817 67 04-12	SCREW HEX WASHER TRI-LOBE 1/4-20 X 3/4

**NOTE:** All component dimensions given in U.S. inches. 1 inch = 25.4 mm  
**IMPORTANT:** Use only Original Equipment Manufacturer (O.E.M.) replacement parts.  
 Failure to do so could be hazardous, damage your snow thrower and void your warranty.

# REPAIR PARTS

# AUGER HOUSING / IMPELLER ASSEMBLY

SNOW THROWER - MODEL NO. ST 330 P (96193009404), PRODUCT NO. 961 93 00-94

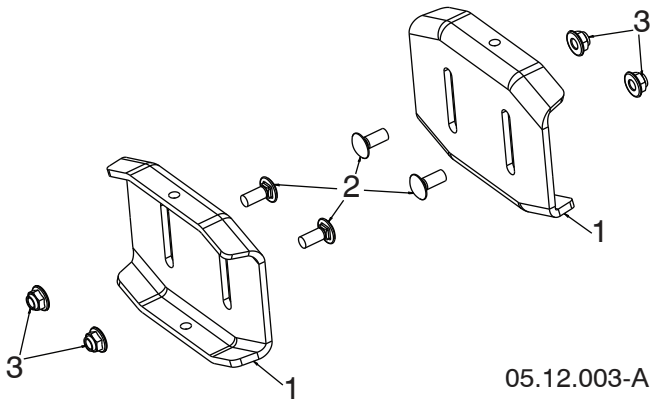

KEY NO.	PART NO.	DESCRIPTION
1	532 40 78-34	SKID PLATE
2	585 69 17-01	BOLT CARRIAGE 5/16-18 X .750 – BLK
3	585 69 13-01	NUT FLANGE NYLOCK 5/16-18 – BLK

05.12.003-A

**NOTE:** All component dimensions given in U.S. inches. 1 inch = 25.4 mm  
**IMPORTANT:** Use only Original Equipment Manufacturer (O.E.M.) replacement parts.  
Failure to do so could be hazardous, damage your snow thrower and void your warranty.

# REPAIR PARTS

# CONTROL PANEL / DISCHARGE CHUTE

SNOW THROWER - MODEL NO. ST 330 P (96193009404), PRODUCT NO. 961 93 00-94

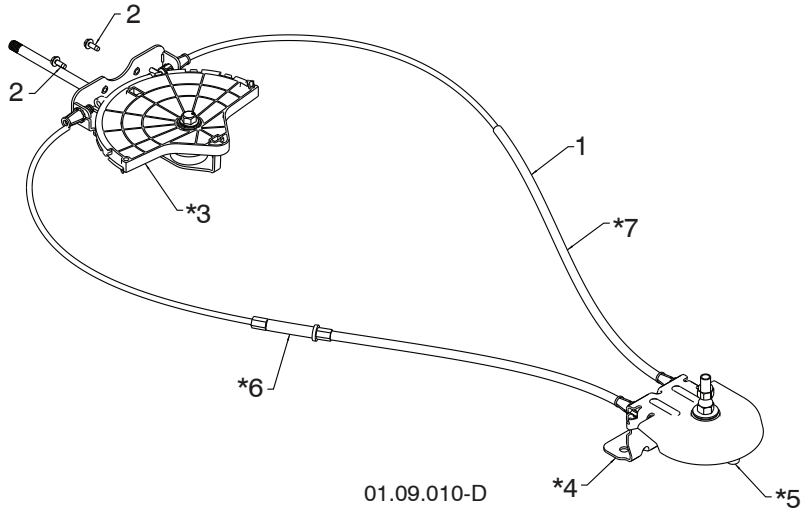

KEY NO.	PART NO.	DESCRIPTION
1	532 42 82-72	LEVER/CABLE ROTATOR ASSEMBLY
2	817 54 10-08	THREAD ROLLING SCREW 10-24 X .500
*3	532 42 06-78	ROTATOR HEAD
*4	585 19 92-01	ROTATOR PIVOT BRACKET
*5	532 42 06-75	PULLEY PIVOT
*6	532 42 82-73	CABLE ASSEMBLY ADJUSTABLE
*7	532 42 83-10	CABLE ASSEMBLY HEAT SHIELD

**NOTES:**

1. ITEMS INDICATED WITH AN \* ARE LISTED AS REFERENCE FOR SERVICE PARTS ONLY.

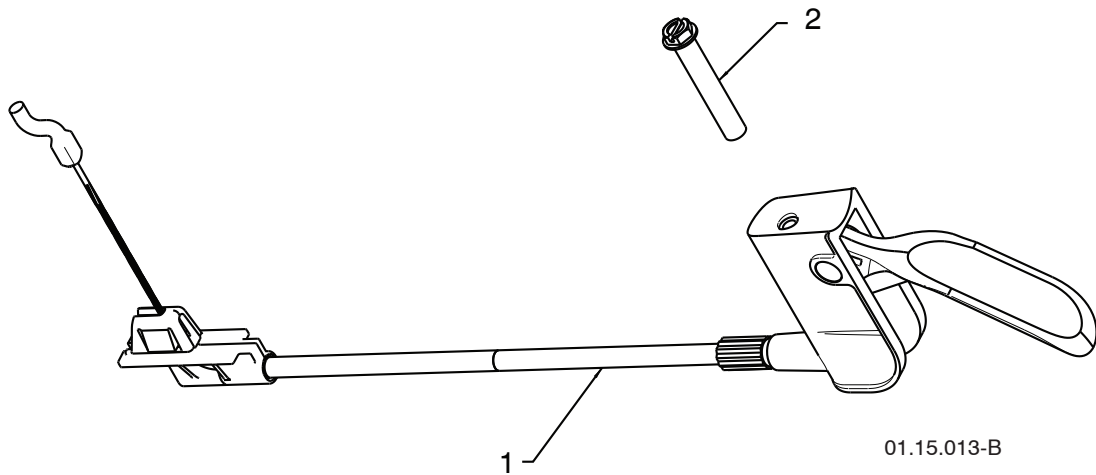

KEY NO.	PART NO.	DESCRIPTION
1	532 42 57-99	STEER CABLE
2	874 04 10-24	SCREW 10-24 X 1.50

**NOTE:** All component dimensions given in U.S. inches. 1 inch = 25.4 mm  
**IMPORTANT:** Use only Original Equipment Manufacturer (O.E.M.) replacement parts. Failure to do so could be hazardous, damage your snow thrower and void your warranty.

# REPAIR PARTS

# CONTROL PANEL / DISCHARGE CHUTE

SNOW THROWER - MODEL NO. **ST 330 P** (96193009404), PRODUCT NO. 961 93 00-94

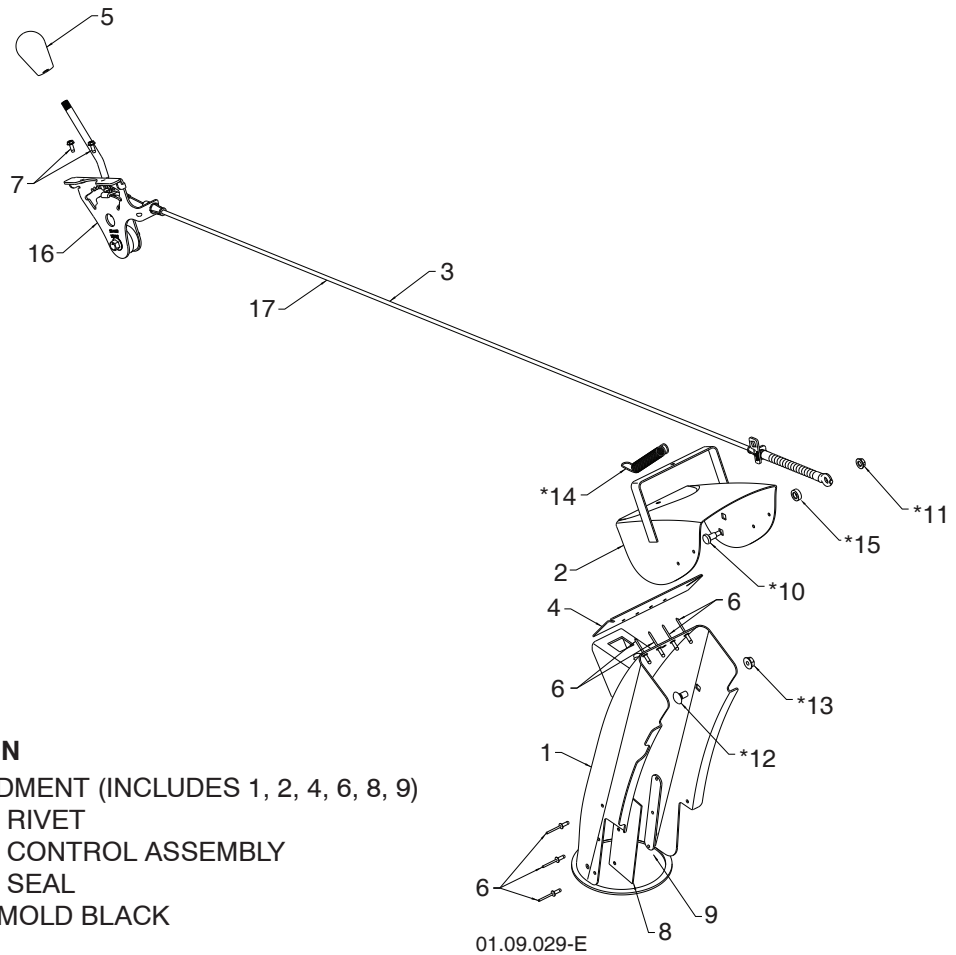

KEY NO.	PART NO.	DESCRIPTION
1	588 07 78-02	CHUTE WELDMENT (INCLUDES 1, 2, 4, 6, 8, 9)
2	-----	DEFLECTOR RIVET
3	587 03 08-01	DEFLECTOR CONTROL ASSEMBLY
4	-----	DEFLECTOR SEAL
5	580 67 32-01	KNOB OVERMOLD BLACK
6	-----	POP RIVET
7	817 54 10-08	THREAD ROLLING SCREW 10-24 X .500
8	-----	CHUTE SNOW SHIELD
9	-----	SHIELD RETAINER STRAP
*10	501 41 73-01	CARRIAGE BOLT 1/4-20 X .544
*11	532 19 17-30	NUT 1/4-20
*12	585 83 20-01	CARRIAGE BOLT BLACK 5/16-18 X 5/8
*13	873 97 05-00	NUT 5/16-18
*14	532 18 45-05	DEFLECTOR SPRING
*15	501 41 74-01	WASHER .326 X .625 X .205 NYLON
16	532 42 06-79	DEFLECTOR CONTROL
17	587 13 31-01	DEFLECTOR CABLE BLACK

**NOTE:**

1. ALL ITEMS INDICATED WITH AN \* ARE PROVIDED IN THE BAG OF ITEMS SHIPPED LOOSE WITH PRODUCT.
2. ITEMS 16 AND 17 ARE SERVICE PART NUMBERS TO ALLOW PURCHASE OF INDIVIDUAL ITEMS IF NECESSARY.

**NOTE:** All component dimensions given in U.S. inches. 1 inch = 25.4 mm  
**IMPORTANT:** Use only Original Equipment Manufacturer (O.E.M.) replacement parts. Failure to do so could be hazardous, damage your snow thrower and void your warranty.



# REPAIR PARTS

# CONTROL PANEL / DISCHARGE CHUTE

SNOW THROWER - MODEL NO. ST 330 P (96193009404), PRODUCT NO. 961 93 00-94

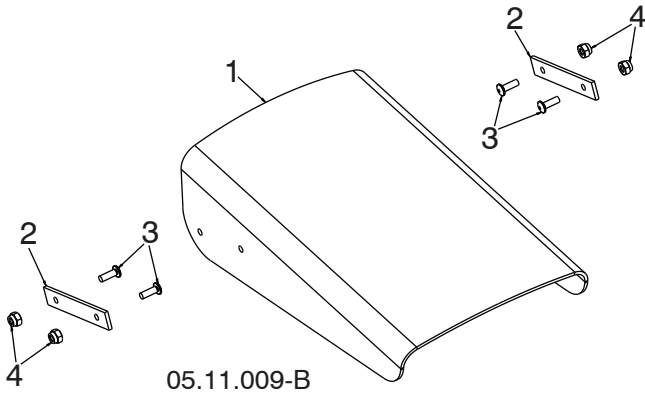

KEY NO.	PART NO.	DESCRIPTION
1	532 42 11-38	SHIELD DEFLECTOR
2	532 42 32-47	STRAP
3	586 11 80-01	SCREW MACHINE 8-32 X .50 BLK
4	586 11 81-01	NUT HEX NYLOCK 8-32 - BLK

**NOTE:** All component dimensions given in U.S. inches. 1 inch = 25.4 mm  
**IMPORTANT:** Use only Original Equipment Manufacturer (O.E.M.) replacement parts.  
Failure to do so could be hazardous, damage your snow thrower and void your warranty.

# REPAIR PARTS

# CONTROL PANEL / DISCHARGE CHUTE

SNOW THROWER - MODEL NO. **ST 330 P** (96193009404), PRODUCT NO. 961 93 00-94

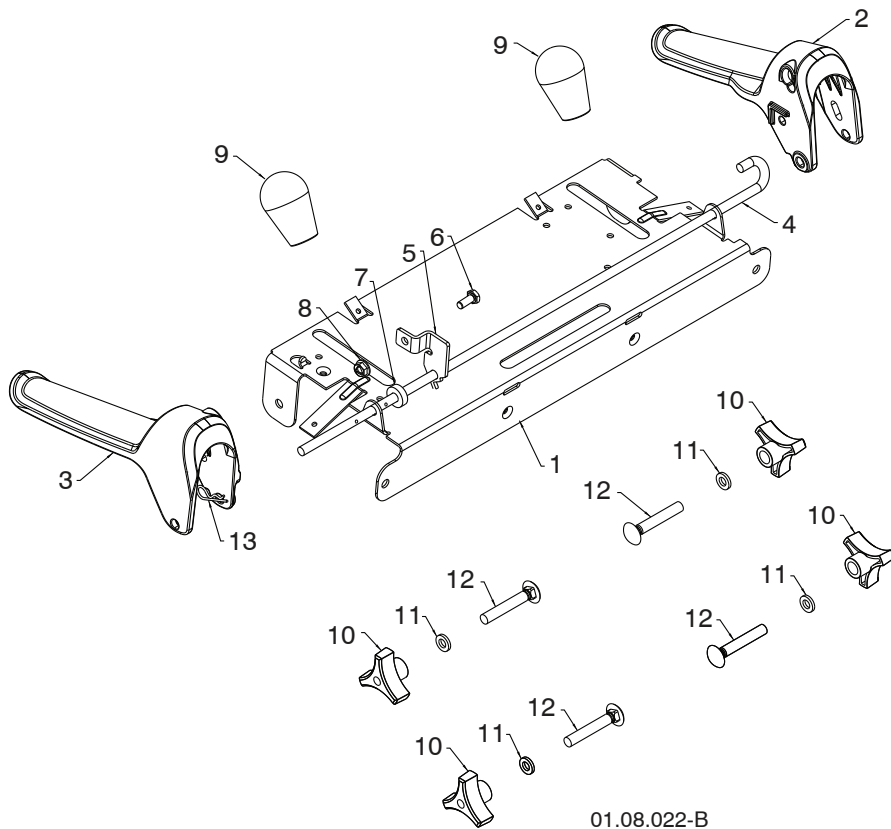

KEY NO.	PART NO.	DESCRIPTION
1	585 19 88-02	CONTROL PANEL
2	581 77 98-01	LH CONTROL LEVER
3	581 77 97-01	RH CONTROL LEVER
4	584 80 90-01	INTERLOCK CONTROL ROD
5	585 00 47-03	INTERLOCK BRACKET
6	874 78 04-10	1/4-20 X .625 HEX HEAD SCREW
7	532 42 16-13	SPACER
8	532 08 83-49	1/4-20 FLANGE NUT (TOP LOCK)
9	580 67 32-01	KNOB SOFT TOUCH
10	532 17 88-99	HANDLE KNOB
11	819 13 13-16	3/8 WASHER
12	872 12 06-18	CARRIAGE BOLT 3/8-16 X 2.25
13	532 16 96-75	RETAINER

**NOTE:** All component dimensions given in U.S. inches. 1 inch = 25.4 mm  
**IMPORTANT:** Use only Original Equipment Manufacturer (O.E.M.) replacement parts. Failure to do so could be hazardous, damage your snow thrower and void your warranty.

# REPAIR PARTS

# HANDLES

SNOW THROWER - MODEL NO. ST 330 P (96193009404), PRODUCT NO. 961 93 00-94

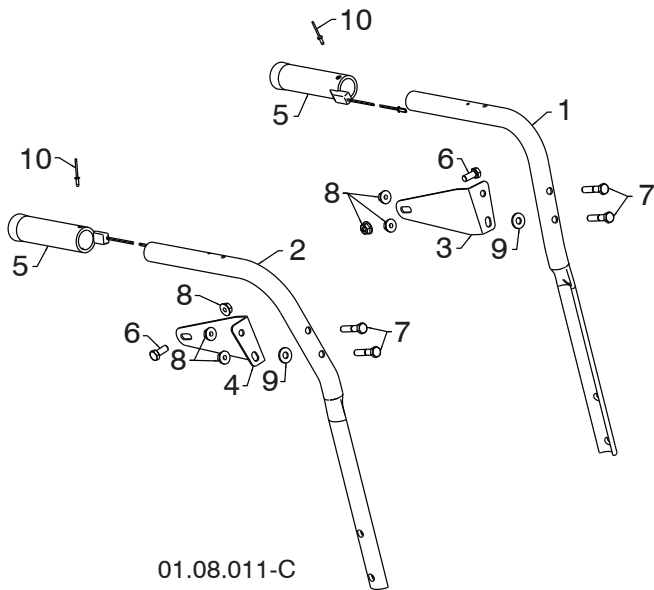

KEY NO.	PART NO.	DESCRIPTION
1	532 42 17-08	PLOW HANDLE LH
2	532 42 17-09	PLOW HANDLE RH
3	532 42 91-48	PANEL BRACKET LH
4	532 42 91-49	PANEL BRACKET RH
5	532 41 45-15	HEATED HANDLE GRIP
6	874 78 05-12	SCREW 5/16-18 X .750
7	874 78 05-24	SCREW 5/16-18 X 1.50
8	532 75 11-53	NUT 5/16-18
9	532 15 54-15	WASHER
10	532 17 87-75	POP RIVET 1/8

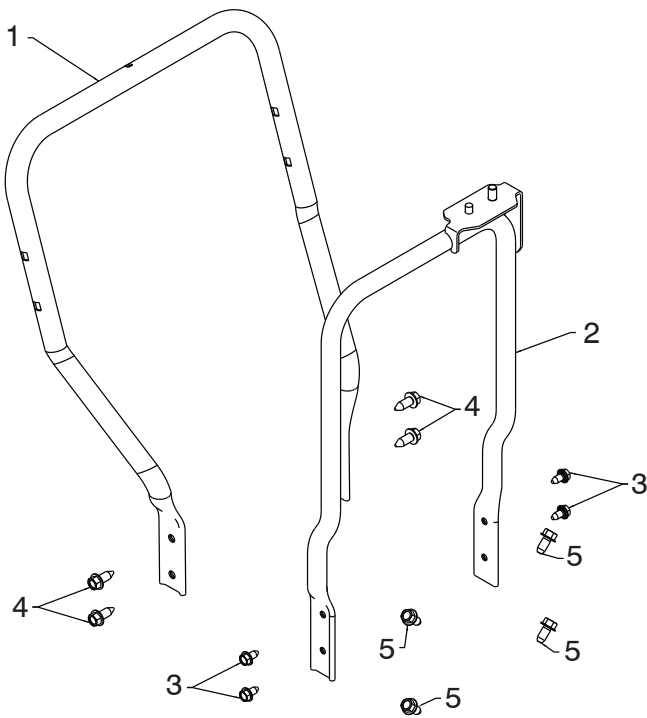

KEY NO.	PART NO.	DESCRIPTION
1	585 23 81-03	LOWER HANDLE
2	532 44 36-17	PIVOT SUPPORT WELDMENT
3	817 00 05-10	SCREW 5/16-18 X .750
4	817 00 06-16	SCREW 3/8-16 X 1.00
5	817 00 06-12	SCREW 3/8-16 X .750

**NOTE:** All component dimensions given in U.S. inches. 1 inch = 25.4 mm  
**IMPORTANT:** Use only Original Equipment Manufacturer (O.E.M.) replacement parts. Failure to do so could be hazardous, damage your snow thrower and void your warranty.

# REPAIR PARTS

# HANDLES

SNOW THROWER - MODEL NO. ST 330 P (96193009404), PRODUCT NO. 961 93 00-94

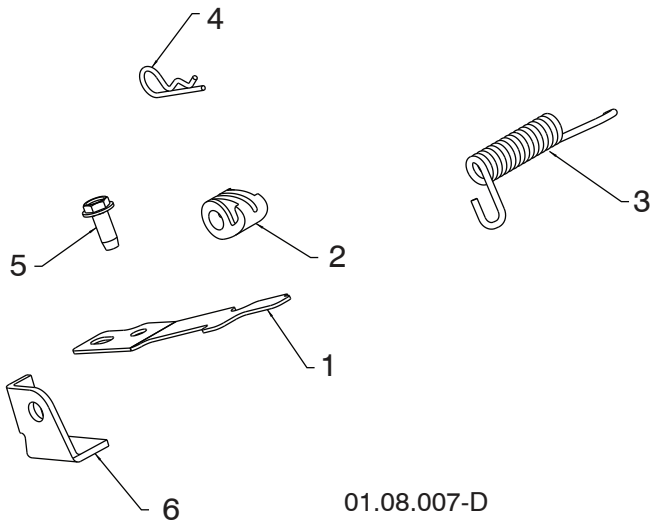

01.08.007-D

KEY NO.	PART NO.	DESCRIPTION
1	532 41 62-88	INTERLOCK SPRING
2	532 44 52-91	INTERLOCK CAM
3	532 44 32-15	TORSION SPRING
4	532 16 96-75	RETAINER
5	817 06 04-10	SCREW 1/4-20 X .625
6	532 42 18-14	INTERLOCK STOP

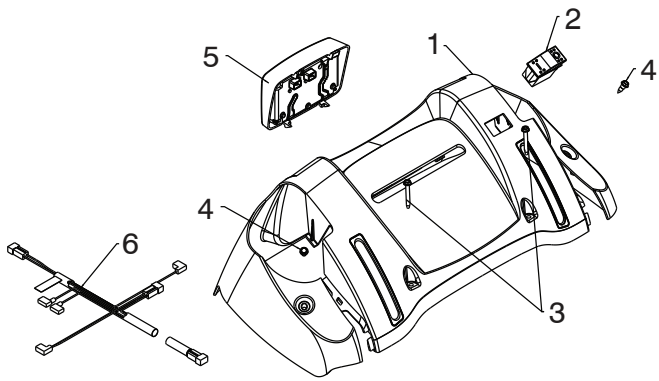

01.10.057-A

KEY NO.	PART NO.	DESCRIPTION
1	532 42 13-51	CONSOLE PANEL
2	532 41 77-60	SWITCH GRIP
3	532 17 52-62	SCREW HX WHSR HEAD 10-24 X 1.25
4	532 18 44-71	SCREW SHOULDER 10-24 X .62
5	581 68 42-01	LED LIGHT DUAL STAGE GRAY
6	580 62 56-01	WIRE HARNESS FLOOD / LED HEATED

**NOTE:** All component dimensions given in U.S. inches. 1 inch = 25.4 mm  
**IMPORTANT:** Use only Original Equipment Manufacturer (O.E.M.) replacement parts.  
 Failure to do so could be hazardous, damage your snow thrower and void your warranty.

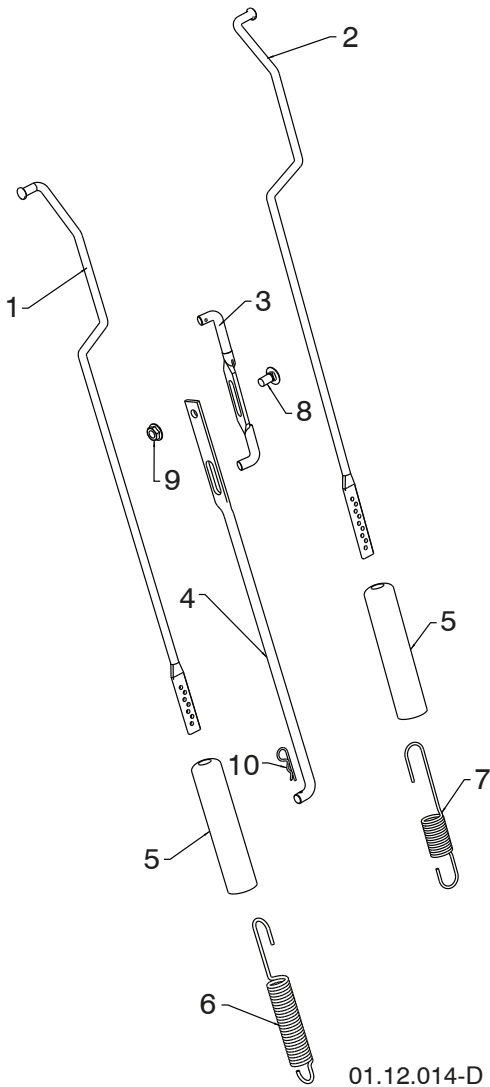

KEY NO.	PART NO.	DESCRIPTION
1	584 80 87-01	ROD IMPELLER CONTROL
2	584 80 88-01	ROD TRACTION CONTROL
3	532 42 55-98	SHIFTER ROD TOP
4	532 18 77-84	SHIFTER ROD BOTTOM
5	532 18 04-47	SPRING SLEEVE
6	580 79 62-01	SPRING CONTROL ROD
7	580 80 21-01	SPRING TRACTION ROD
8	872 27 05-05	CARRIAGE BOLT 5/16-18 X .75
9	532 15 53-77	NUT 5/16-18
10	532 16 96-75	RETAINER HAIRPIN

**NOTE:** HOOK TRACTION ROD SPRING IN HOLE 9  
HOOK IMPELLER ROD SPRING IN HOLE 4

01.12.014-D

**NOTE:** All component dimensions given in U.S. inches. 1 inch = 25.4 mm  
**IMPORTANT:** Use only Original Equipment Manufacturer (O.E.M.) replacement parts.  
Failure to do so could be hazardous, damage your snow thrower and void your warranty.



## SNOW THROWER - MODEL NO. ST 330 P (96193009404), PRODUCT NO. 961 93 00-94

KEY NO.	PART NO.	DESCRIPTION
1	532 44 33-44	SHIFT BRACKET
2	817 54 10-08	THREAD ROLLING SCREW 10-24 X .500
3	874 76 05-52	SCREW 5/16-18 X 3.25
4	532 17 92-46	PLASTIC WASHER
5	532 42 55-96	SHIFT ASSEMBLY
6	532 15 54-15	WASHER
7	532 19 21-95	FRICTION SPRING
8	873 80 05-00	NUT 5/16-18 LOCK
9	532 44 33-47	CABLE MOUNTING BRACKET RH
10	532 42 88-67	SCREW 5/16-18 X .750
11	532 40 54-85	CONTROL ARM
12	532 19 85-80	CLEVIS PIN
13	532 43 71-51	REAR PLATE
14	532 05 70-79	WASHER
15	532 42 75-42	CONTROL SHAFT
16	532 44 33-50	STEER LEVER
17	532 44 33-49	PIVOT PLATE
18	532 44 33-48	REAR CLUTCH BRACKET
19	532 19 82-49	CLUTCH ARM
20	532 42 82-88	E-RING .375
21	532 40 28-81	SHOULDER BOLT 1/4-20
22	532 19 17-30	NUT 1/4-20 SIDELOCK
23	532 06 53-22	HAIRPIN RETAINER SMALL
24	532 42 54-96	STEER ROD
25	532 19 41-24	RETURN SPRING
26	532 44 33-46	STABILIZER BRACKET
27	532 44 33-45	TRANSMISSION MOUNTING BRACKET
28	874 88 04-32	SCREW 1/4-20 X 2.00
29	874 76 05-16	BOLT 5/16-18 X 1.00
30	532 75 11-53	NUT 5/16-18 TOP LOCK
31	532 19 82-51	CLUTCH SHAFT
32	532 44 62-93	CLUTCH ROD
33	532 70 02-79	RETAINER CLIP
34	532 42 54-99	SPEED CONTROL ROD
35	532 16 96-75	HAIRPIN RETAINER LARGE
36	532 42 98-03	FRONT CLUTCH BRACKET
37	532 18 03-55	CARRIAGE BOLT 5/16-18 X .625
38	501 11 13-01	HYDROSTATIC TRANSMISSION
39	532 17 88-28	BRAKE SPRING
40	532 42 54-98	BOTTOM PAN
41	532 18 44-71	SHOULDER SCREW 10-24
42	532 05 38-47	WASHER
43	873 80 04-00	NUT 1/4-20 NYLOCK
44	532 40 65-58	RETURN SPRING
45	584 99 45-01	BELT GUIDE HYDRO 2

**NOTE:** All component dimensions given in U.S. inches. 1 inch = 25.4 mm

**IMPORTANT:** Use only Original Equipment Manufacturer (O.E.M.) replacement parts. Failure to do so could be hazardous, damage your snow thrower and void your warranty.

# REPAIR PARTS

# DRIVE

SNOW THROWER - MODEL NO. **ST 330 P** (96193009404), PRODUCT NO. 961 93 00-94

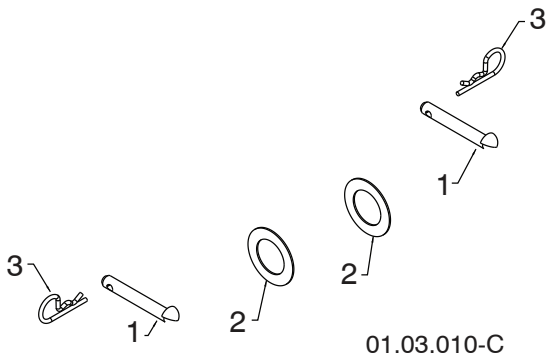

KEY NO.	PART NO.	DESCRIPTION
1	532 17 12-71	RIVET
2	532 12 49-31	THRUST WASHER
3	532 12 47-88	RETAINER

**NOTE:** All component dimensions given in U.S. inches. 1 inch = 25.4 mm  
**IMPORTANT:** Use only Original Equipment Manufacturer (O.E.M.) replacement parts. Failure to do so could be hazardous, damage your snow thrower and void your warranty.



# REPAIR PARTS

# CHASSIS / ENGINE / PULLEYS

SNOW THROWER - MODEL NO. ST 330 P (96193009404), PRODUCT NO. 961 93 00-94

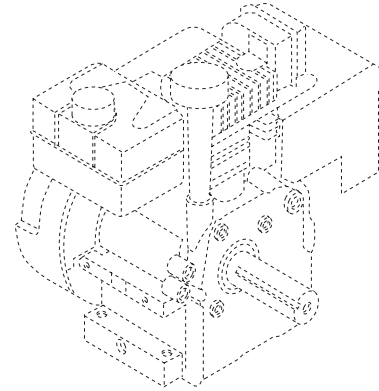
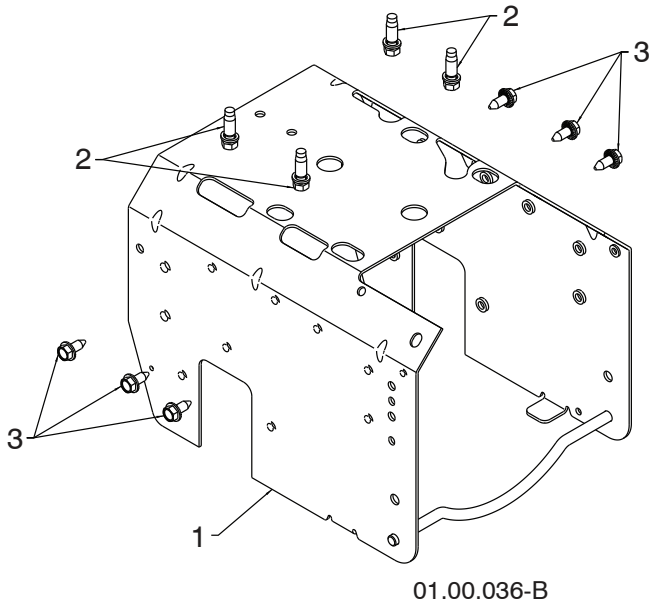

KEY NO.	PART NO.	DESCRIPTION
--	585 74 27-03	COMPLETE LCT ENGINE PW2HK181000178E
1	586 50 78-03	FRAME
2	532 15 04-06	BOLT 3/8 - 16
3	532 42 88-67	SCREW 5/16-18 X .750

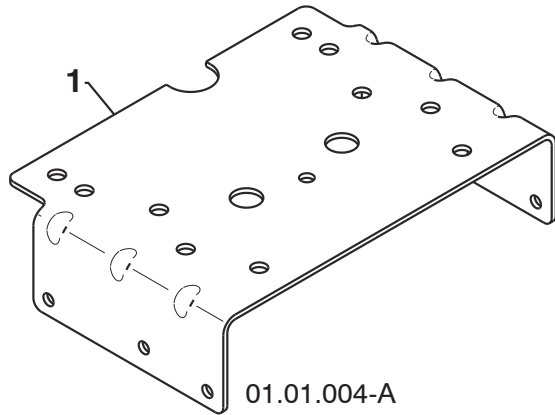

KEY NO.	PART NO.	DESCRIPTION
1	532 42 92-69	ENGINE MOUNTING PLATE

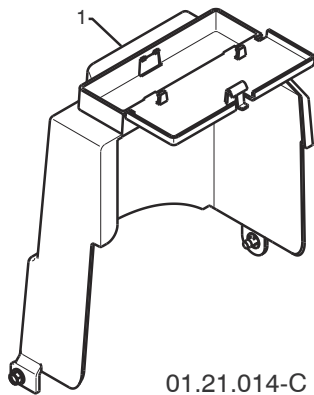

KEY NO.	PART NO.	DESCRIPTION
1	532 42 86-85	COVER ASSEMBLY

**NOTE:** All component dimensions given in U.S. inches. 1 inch = 25.4 mm  
**IMPORTANT:** Use only Original Equipment Manufacturer (O.E.M.) replacement parts.  
 Failure to do so could be hazardous, damage your snow thrower and void your warranty.

# REPAIR PARTS

# CHASSIS / ENGINE / PULLEYS

SNOW THROWER - MODEL NO. ST 330 P (96193009404), PRODUCT NO. 961 93 00-94

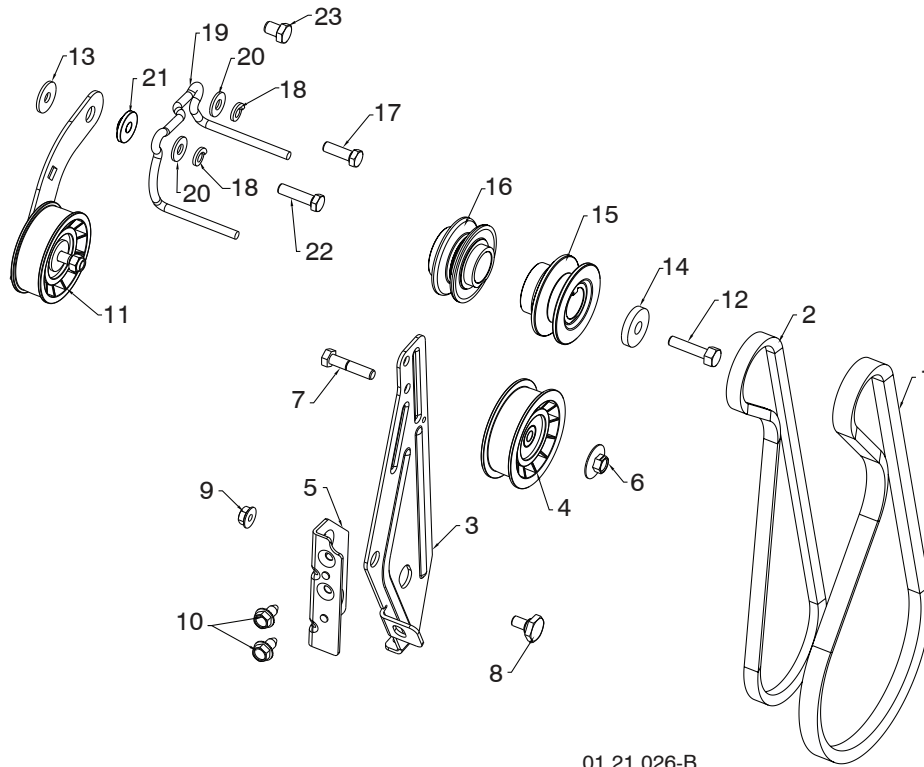

01.21.026-B

KEY NO.	PART NO.	DESCRIPTION	KEY NO.	PART NO.	DESCRIPTION
1	532 41 98-88	IMPELLER BELT	12	532 17 96-17	SCREW 3/8-24 X 1.375 GR8
2	532 41 35-92	TRACTION BELT	13	532 05 92-89	WASHER
3	584 23 24-02	IDLER ARM BRACKET	14	819 13 20-05	WASHER
4	532 18 05-23	IDLER PULLEY	15	586 05 08-01	PULLEY ENGINE IMPELLER
5	585 28 49-01	IDLER BRACKET	16	586 05 11-01	PULLEY ENGINE TRACTION
6	532 42 65-89	NUT 5/16-18	17	874 61 05-16	SCREW 5/16-24 X 1.00 GR5
7	874 78 05-24	SCREW 5/16-18 X 1.50 GR5	18	810 04 05-00	LOCKWASHER 5/16
8	532 42 42-97	SHOULDER BOLT 5/16-18 X .50 GR2	19	585 54 05-01	BELT GUIDE
9	532 75 11-53	NUT 5/16-18 LOCK	20	532 15 54-15	WASHER .20 X 8.5 X 2.0
10	817 00 05-10	SCREW 5/16-18 X .625	21	587 34 37-01	IDLER BUSHING
11	585 23 84-01	TRACTION IDLER BRACKET ASM	22	874 61 05-20	SCREW 5/16-24 X 1.25 GR5
			23	874 76 06-08	SCREW 3/8-16 X .500 GR2

**NOTE:** All component dimensions given in U.S. inches. 1 inch = 25.4 mm  
**IMPORTANT:** Use only Original Equipment Manufacturer (O.E.M.) replacement parts.  
 Failure to do so could be hazardous, damage your snow thrower and void your warranty.

# REPAIR PARTS

# WHEELS

SNOW THROWER - MODEL NO. ST 330 P (96193009404), PRODUCT NO. 961 93 00-94

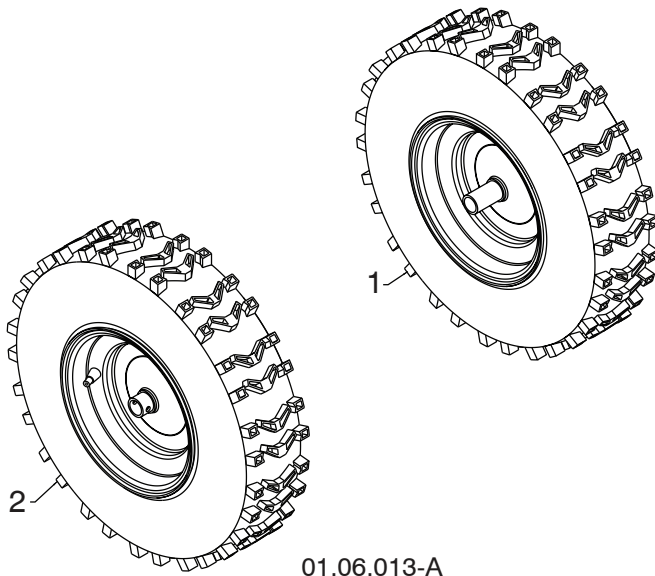

KEY NO.	PART NO.	DESCRIPTION
1	532 44 87-12	WHEEL ASSEMBLY LH
2	532 44 87-13	WHEEL ASSEMBLY RH

**NOTE:** All component dimensions given in U.S. inches. 1 inch = 25.4 mm  
**IMPORTANT:** Use only Original Equipment Manufacturer (O.E.M.) replacement parts.  
Failure to do so could be hazardous, damage your snow thrower and void your warranty.

# REPAIR PARTS

# BAG OF PARTS

## SNOW THROWER - MODEL NO. ST 330 P (96193009404), PRODUCT NO. 961 93 00-94

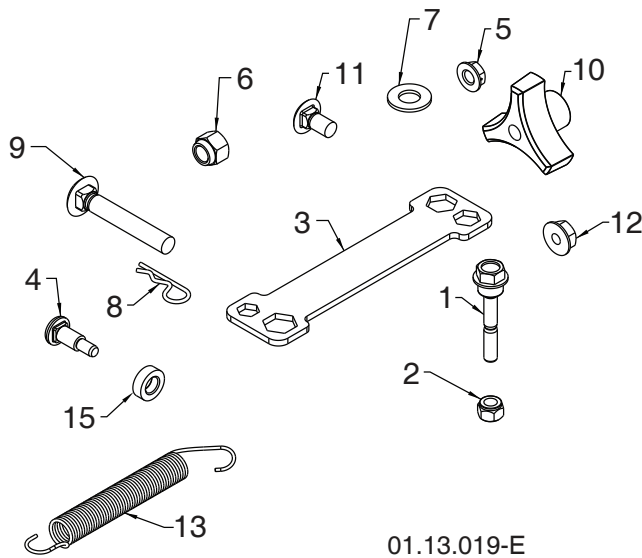

01.13.019-E

KEY NO.	PART NO.	DESCRIPTION
1	588 07 75-01	BOLT SHEAR 1/4-20
2	873 80 04-00	NUT NYLOCK 1/4-20
3	532 42 91-12	WRENCH
4	501 41 73-01	BOLT SHOULDER
5	532 19 17-30	NUT HEX FL 1/4-20 CTR
6	873 80 06-00	NUT NYLOCK 3/8-16
7	819 13 13-16	WASHER FLAT 3/8 SAE
8	532 16 96-75	RETAINER HAIRPIN
9	872 12 06-18	BOLT 3/8-16 X 2.25
10	532 17 88-99	KNOB 3/8-16 TRI LOBE
11	585 83 20-01	BOLT BLACK 5/16-18 X 5/8
12	873 97 05-00	NUT FL LOCK 5/16-18
13	532 18 45-05	SPRING DEFLECT CHUTE
14	580 94 77-01	BAG PLASTIC 11X16 WARNING
15	501 41 74-01	WASHER NYLON
NI	532 40 97-80	SHEAR BOLT KIT
NI	588 55 63-01	BAG OF PARTS

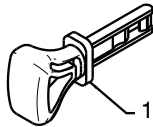

01.14.009-B

KEY NO.	PART NO.	DESCRIPTION
1	532 44 30-59	SAFETY IGNITION KEY KIT

**NOTE:** All component dimensions given in U.S. inches. 1 inch = 25.4 mm  
**IMPORTANT:** Use only Original Equipment Manufacturer (O.E.M.) replacement parts. Failure to do so could be hazardous, damage your snow thrower and void your warranty.

**REPAIR PARTS**

**BAG OF PARTS**

**SNOW THROWER - MODEL NO. ST 330 P (96193009404), PRODUCT NO. 961 93 00-94**

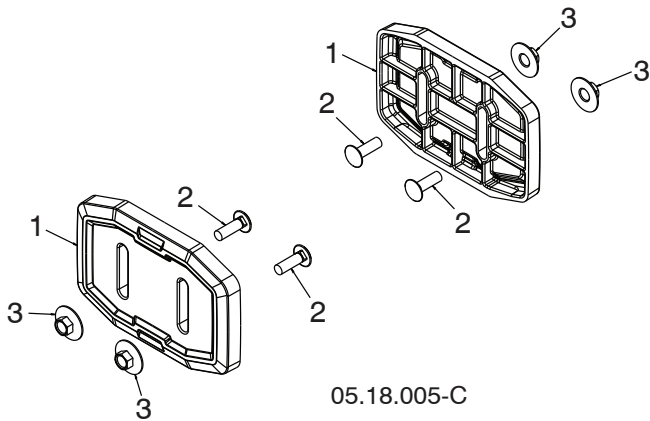

KEY NO.	PART NO.	DESCRIPTION
1	583 83 88-01	SKID PLATE UHMW
2	532 43 73-18	BOLT CARRIAGE 5/16-18 X 1.00 - BLK
3	585 80 28-01	NUT LRG FLANGE LOCK 5/16-18 - BLK

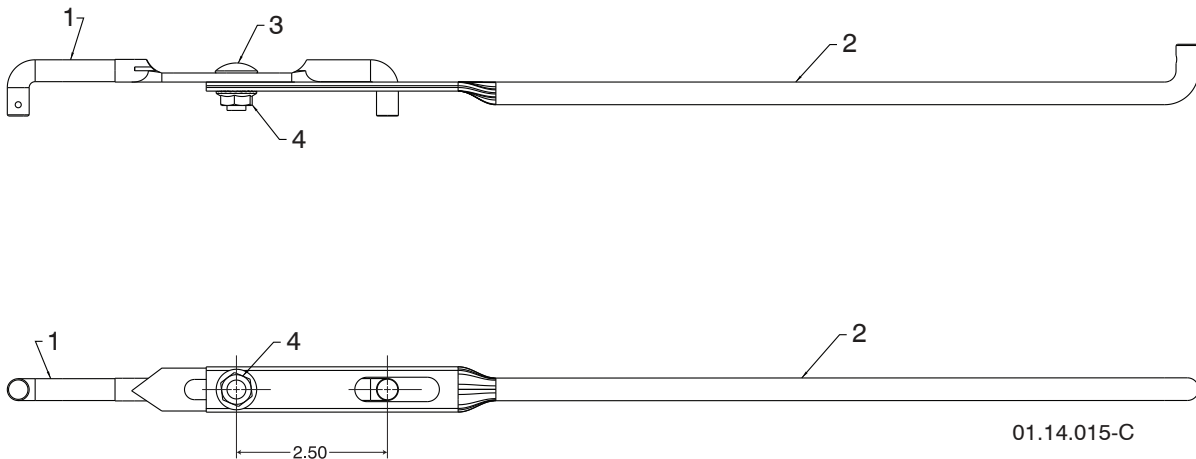

KEY NO.	PART NO.	DESCRIPTION
1	532 42 55-98	SHIFTER ROD TOP
2	532 18 77-84	SHIFTER ROD BOTTOM
3	872 27 05-05	CARRIAGE BOLT 5/16-18 X .75
4	532 15 53-77	NUT 5/16-18

**NOTE:** All component dimensions given in U.S. inches. 1 inch = 25.4 mm  
**IMPORTANT:** Use only Original Equipment Manufacturer (O.E.M.) replacement parts.  
 Failure to do so could be hazardous, damage your snow thrower and void your warranty.

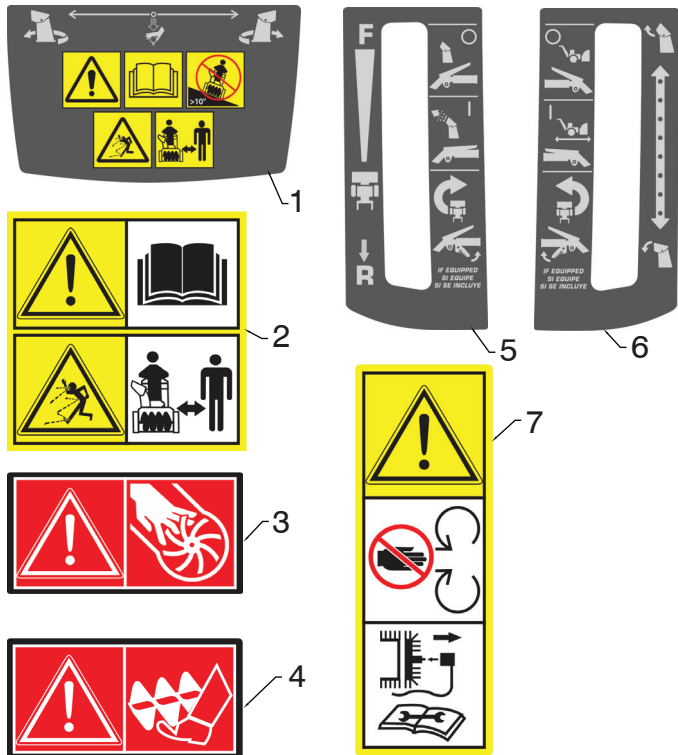

KEY NO.	PART NO.	DESCRIPTION
1	532 42 95-75	DECAL CONSOLE INSTRUCTIONS
2	532 18 40-45	DECAL AUGER
3	590 81 22-01	DECAL CHUTE
4	532 19 96-83	DECAL AUGER SAFETY
5	585 76 87-01	DECAL CONSOLE RH INSTRUCTIONS
6	585 76 87-02	DECAL CONSOLE LH INSTRUCTIONS
7	532 18 40-28	DECAL BELT GUARD

05.16.003-A

**NOTE:** All component dimensions given in U.S. inches. 1 inch = 25.4 mm  
**IMPORTANT:** Use only Original Equipment Manufacturer (O.E.M.) replacement parts. Failure to do so could be hazardous, damage your snow thrower and void your warranty.

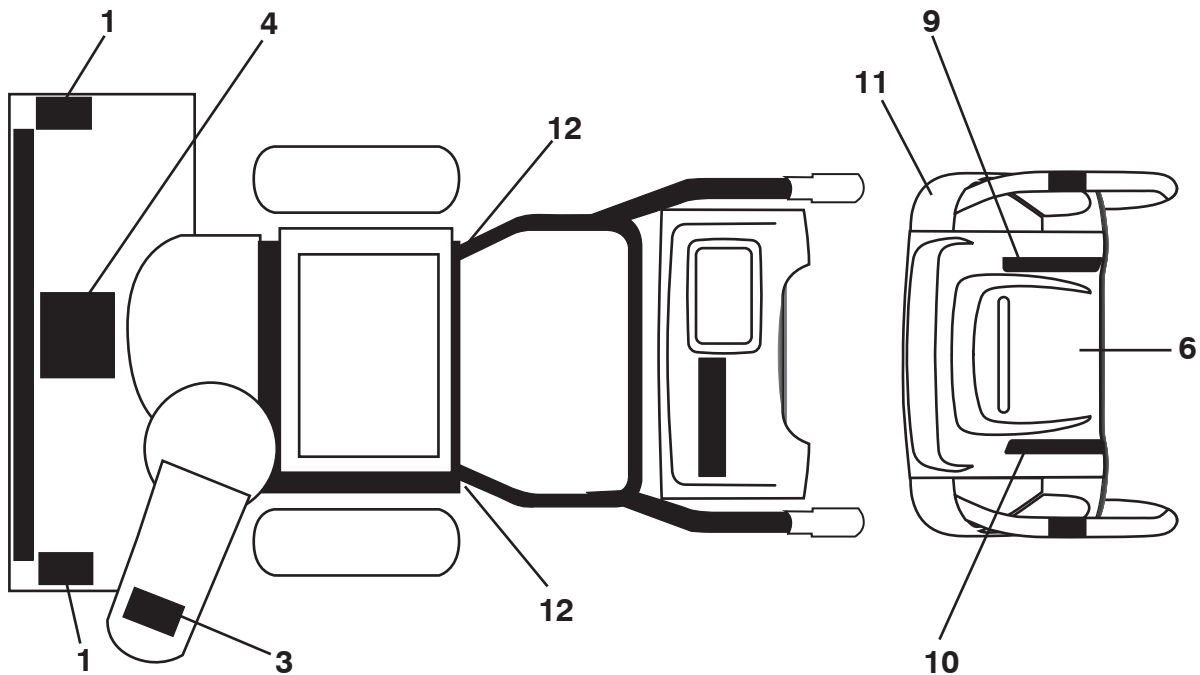

KEY NO.	PART NO.	DESCRIPTION
1	532 19 96-83	DECAL, DANGER
3	590 81 22-01	DECAL, DANGER, DEFLECTOR
4	532 18 40-45	DECAL, DANGER
6	532 42 95-75	DECAL, INSTRUCTION
9	585 76 87-01	DECAL, CONS RT
10	585 76 87-02	DECAL, CONS LT
11	532 44 47-68	DECAL, HANDWARMER
12	532 18 40-28	DECAL, BELT GUARD
--	586 93 55-01	DECAL, CONSOLE
--	586 43 16-01	DECAL, ENGINE RECOIL
--	115 73 38-27	OPERATOR'S MANUAL, ENGLISH
--	115 73 38-31	OPERATOR'S MANUAL, FRENCH
--	115 73 38-46	OPERATOR'S MANUAL, SPANISH

**NOTE:** All component dimensions given in U.S. inches. 1 inch = 25.4 mm  
**IMPORTANT:** Use only Original Equipment Manufacturer (O.E.M.) replacement parts. Failure to do so could be hazardous, damage your snow thrower and void your warranty.

# ENGINE, LCT

# COMPLETE ENGINE-585742703

GEN II 291/306/369/414/420cc Snow Engines

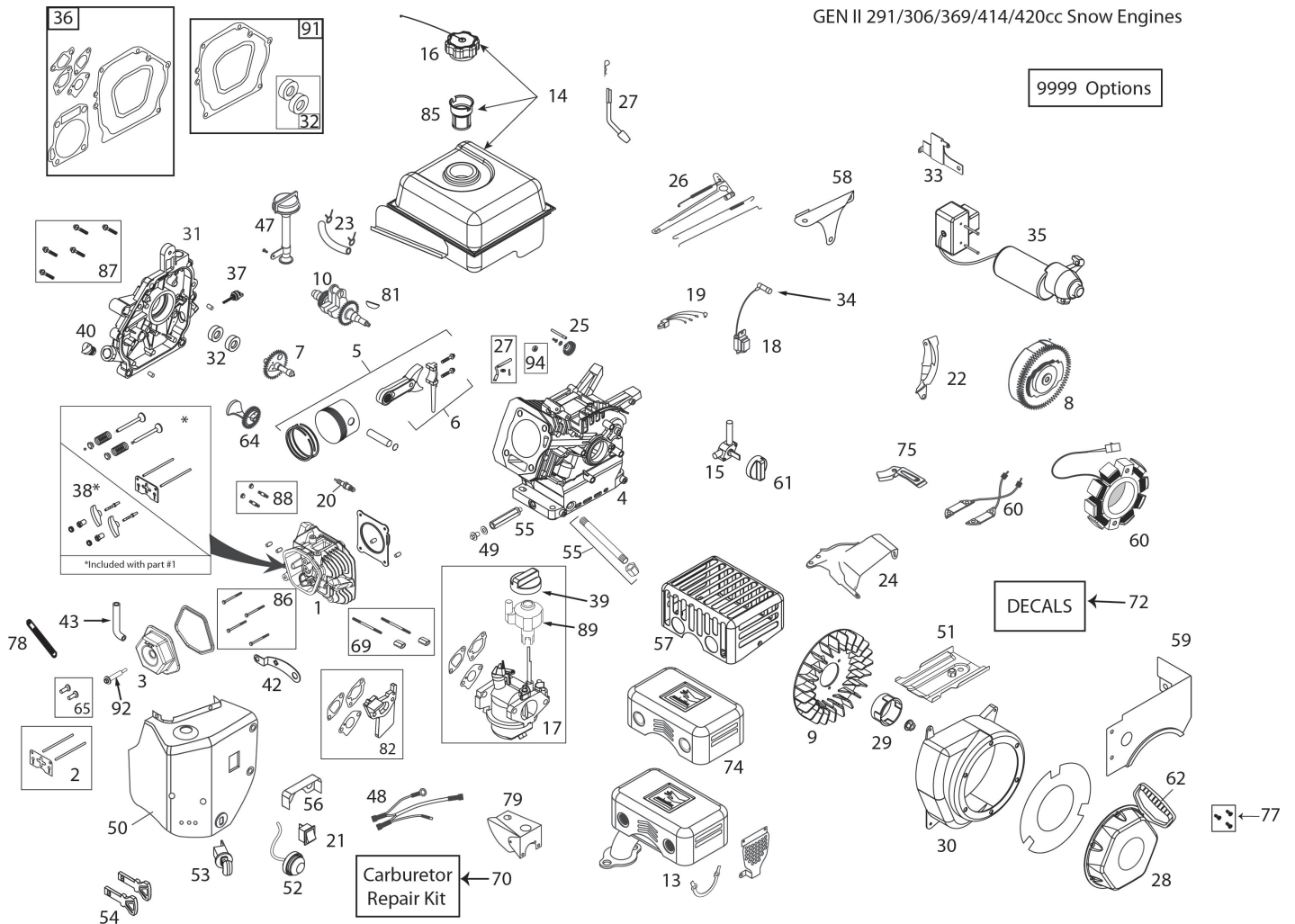

ILLUSTRATION FOR REFERENCE PURPOSES ONLY

## KEY PART NO. NO.

## DESCRIPTION

1	587 17 68-01	CYLINDER HEAD 369CC
2	532 42 96-06	PUSH ROD & PLATE KIT (414CC) (INCL. VALVE COVER GSKT)
3	532 42 93-03	VALVE COVER (291/414CC) (INCL. GASKET)
4	N/A	N/A
5	582 50 52-01	PISTON AND ROD ASSEMBLY 369CC
6	N/A	N/A
7	532 42 93-13	CAMSHAFT - MCR (414CC)
8	532 44 39-00	FLYWHEEL - ELECTRIC START (5-CHARGING MAGNETS) (414CC)
9	532 42 93-06	COOLING FAN - FLYWHEEL (PLASTIC - 414CC)
10	587 15 13-01	CRANKSHAFT - #18 369/414CC
13	587 19 87-01	QUIET MUFFLER-HOP-369CC-SNOW

## KEY PART NO. NO.

## DESCRIPTION

14	532 42 92-09	FUEL TANK (3.6L BLACK SNOW 414CC)
15	532 42 92-34	FUEL TANK ON/OFF VALVE (PETCOCK) - GEN II SNOW
16	532 42 92-11	FUEL TANK CAP - BLACK PLASTIC (VENTED)
17	587 17 91-01	CARBURETOR WITH IDLE DOWN 369CC
18	532 44 39-44	CDI IGNITION COIL (291/414CC)
19	N/A	N/A
20	532 42 49-39	SPARK PLUG
21	532 42 92-23	ON/OFF SWITCH - ROCKER
22	532 42 92-32	WIRE GUARD PLATE
23	532 43 21-46	FUEL HOSE KIT (229MM)
24	532 42 92-86	SPEED CONTROL - FIXED
25	532 42 93-12	GOVERNOR GEAR ASSEMBLY
26	532 42 93-10	GOVERNOR ARM & LINK KIT (414CC)



**ENGINE, LCT****COMPLETE ENGINE-585742703**

<b>KEY NO.</b>	<b>PART NO.</b>	<b>DESCRIPTION</b>	<b>KEY NO.</b>	<b>PART NO.</b>	<b>DESCRIPTION</b>
27	532 42 93-11	GOVERNOR ARM PADDLE	56	532 42 92-13	ARBURETOR VAPOR SHIELD
28	582 62 15-01	RECOIL STARTER - BLACK 369/414CC SNOW (JPC)	57	532 43 74-66	CE MUFFLER GUARD
29	582 62 16-01	STARTER CUP - 369/414CC SNOW (JPC)	58	532 42 92-98	SHIELD - GOVERNOR LINKAGE
30	587 39 41-01	BLOWER HOUSING MATTE BLACK 369/414CC (W/FRT OIL DRAIN)	59	582 62 17-01	FUEL TANK SKIRT (369/414CC SNOW) FOR JPC RECOIL
31	580 98 41-01	CYLINDER COVER (HOFT FEA- RURES)(FULL-FACE GASKET SURFACE)	60	532 44 38-96	CHARGING COIL (60-WATT AC) (291/414CC)
32	532 42 93-16	OIL SEAL KIT (414CC)	61	532 43 27-52	FUEL CONTROL KNOB (GEN II SNOW - RED)
33	532 42 92-90	ELECTRIC STARTER SWITCH- BOX BRACKET - 291/414CC SNOW	62	532 44 38-99	STARTER GRIP-SNOW (DELUXE)
34	532 43 69-66	SPARK PLUG BOOT - WITH METAL SHIELD (SNOW)	64	532 42 96-08	COUNTER WEIGHT KIT
35	532 42 92-97	120V ELECTRIC STARTER (414CC)	65	581 37 29-01	TAPPET KIT (291/414CC)(SET OF 2)
36	587 17 94-01	ENGINE GASKET KIT 369CC	69	586 32 67-01	CARBURETOR MTG STUD KIT (2) (414CC)
37	532 43 55-34	SMALL BLACK OIL DIPSTICK (PLASTIC)	70	580 35 37-01	CARBURETOR REPAIR KIT (291/414CC)
38	532 42 96-12	ROCKER ARM KIT (291/414CC) (INCL. GASKET)	72	N/A	N/A
39	532 42 92-24	CHOKE CONTROL KNOB (GEN II RED)	74	587 37 53-01	MUFFLER HEAT SHIELD (369/414CC)
40	532 42 92-42	NON-REMOVABLE PLASTIC PLUG (291/414CC)	75	532 42 92-32	SHIELD - FLYWHEEL (414CC SNOW)
42	N/A	N/A	77	532 43 26-88	RECOIL BOLT KIT (3 BOLTS PER KIT)
43	587 17 96-01	BREATHER TUBE (W/PROTEC- TIVE SLEEVE)	78	585 77 13-01	BREATHER TUBE RETAINING STRAP
47	532 42 92-37	HIGH OIL-FILL TUBE & CAP (NO DIPSTICK)	79	587 15 20-01	SHIELD - CARBURETOR COVER - 291/414CC
48	532 42 92-62	WIRE HARNESS (208CC SNOW)	81	585 29 72-01	WOODRUFF FLYWHEEL KEYS (5-PACK) (5X6X18MM)
49	532 43 54-94	OIL DRAIN PLUG W/WASHER (291/414CC)	82	585 02 05-01	414CC CARBURETOR SPACER KIT
50	532 42 92-94	CARBURETOR HEATER BOX MATTE BLACK - GEN II 369/414CC	85	586 32 56-01	FUEL TANK STRAINER
51	532 42 92-31	SHIELD - CYLLNDER	86	586 32 74-01	CYLINDER HEAD BOLT KIT (4) (291-414CC)
52	532 42 92-18	PRIMER BULB WITH HOSE- SNOW	87	586 32 70-01	CC COVER BOLT KIT (7) (414CC)
53	532 42 92-21	SAFETY KEY SWITCH W/KEYS	88	586 32 68-01	MUFFLER MTG STUD KIT (2)
54	532 44 30-59	KEY SET - RED (2) (SNOW)	89	587 12 48-01	SPEED CONTROL KNOB (GREY)
55	587 13 99-01	OIL DRAIN TUBE (96.5MM) WITH CAP NUT	91	587 99 41-04	CRANKSHAFT GASKET KIT 369- 414CC
			92	587 99 52-01	VALVE COVER BOLT WITH SEAL
			94	588 48 55-01	GOV SHAFT OIL SEAL
			9999	586 32 65-01	HIGH ALTITUDE JET (>6,000 FEET)
			9999	579 80 64-01	BOLT KIT - BLWR HGS/HEATER BOX/TANK SKIRT

