

ILLUSTRATED PARTS LIST

MODEL NO. 96041036702

CUSTOMER CATALOG NO. TS 138

PRODUCT NO. 960 41 03-67

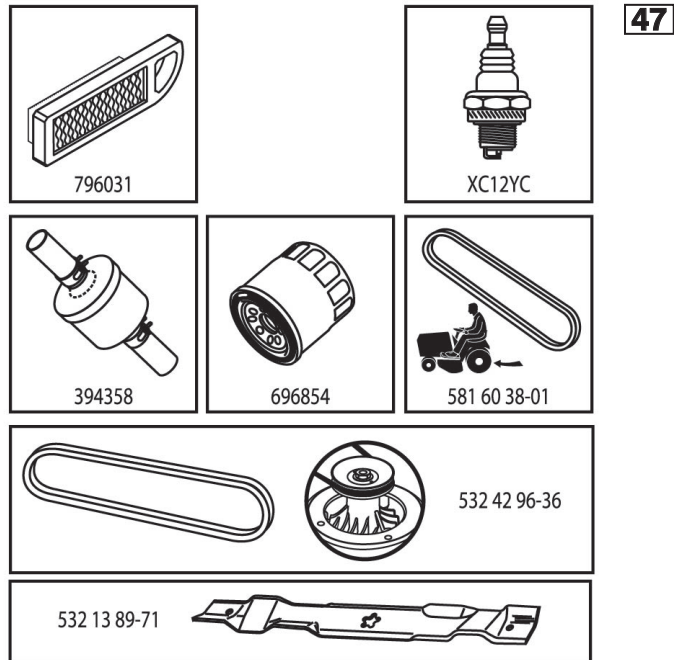

587396001

**TRACTOR - - MODEL NO. TS 138 (96041036702), PRODUCT NO. 960 41 03-67
DECALS 27**

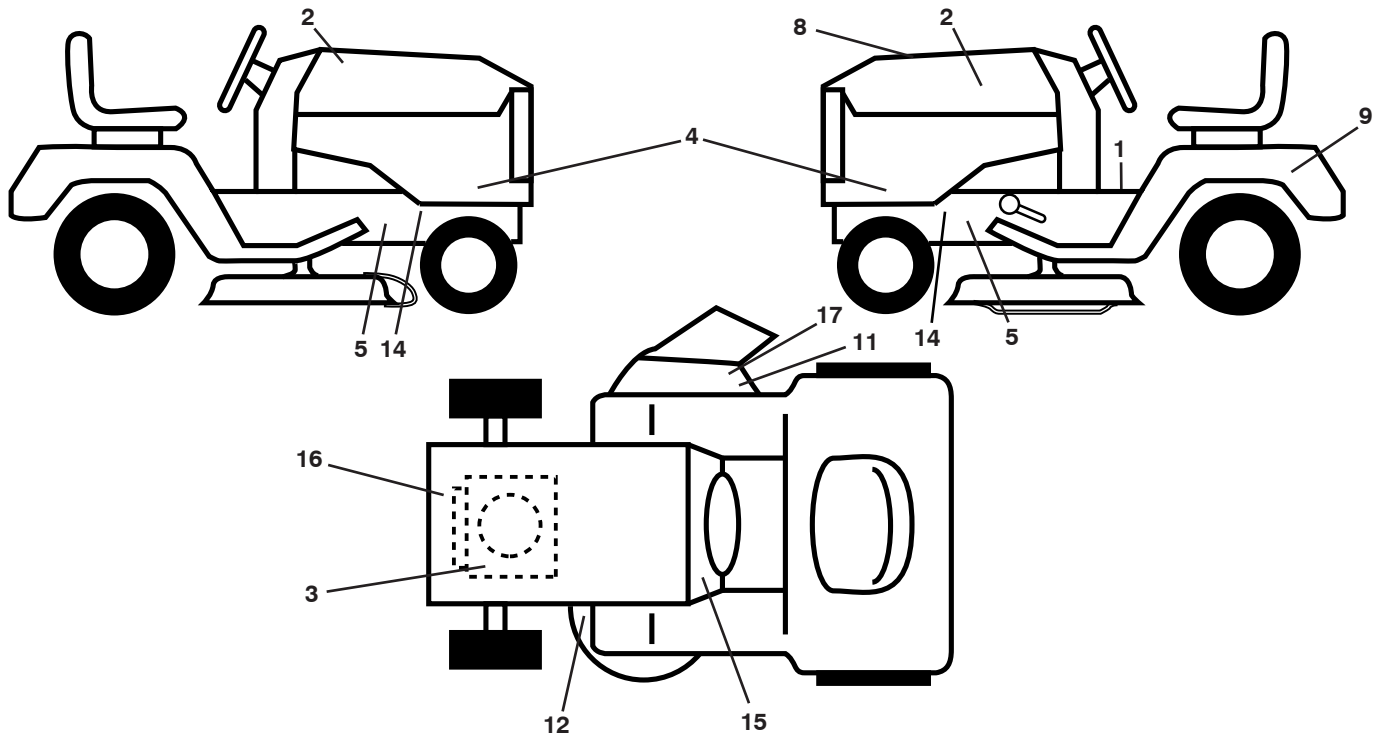

KEY PART NO.	PART NO.	DESCRIPTION
1	586 35 06-01	Decal, Operators
2	581 62 73-01	Hood Emblem
3	581 57 97-01	Decal, Warning Eng. Symbols
4	587 40 73-01	Decal, Hood Panel
5	581 57 96-01	Decal, Chassis Hot Muffler
8	587 39 59-01	Decal, Rpl.
9	532 14 50-05	Decal, Battery Dan./Poi.
11	581 57 92-01	Decal, Warning
12	581 58 00-03	Decal, Mower V-Belt Schematic
14	581 57 98-01	Decal, Warning-Service/Fire
15	586 06 62-01	Decal, Snowflake
16	587 73 12-01	Decal, Eng. BS

KEY PART NO.	PART NO.	DESCRIPTION
17	584 90 46-01	Decal, Deflect. Warning
--	581 72 48-01	Decal, Bypass
--	581 72 46-01	Decal, Drawbar Load Limit
--	532 43 96-81	Pad, Footrest, LH
--	532 43 96-82	Pad, Footrest, RH
--	115 89 86-20	Manual Oper. Euro
--	115 89 85-10	Manual Oper. Scan
--	115 89 87-50	Manual Oper. Ebloc
--	115 89 88-40	Manual Oper. Baltic

WHEELS AND TIRES

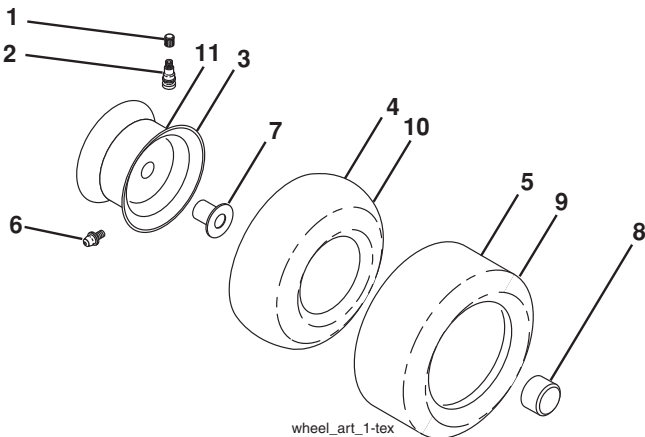

KEY PART NO.	PART NO.	DESCRIPTION
1	532 05 91-92	Cap Valve Tire
2	532 06 51-39	Stem Valve
3	532 13 83-36	Rim Asm. 6" Front
4	532 05 99-04	Tube Front (Service Item Only)
5	532 10 62-22	Tire Front 15 x 6-6
6	532 12 49-57	Fitting Grease (Front Wheel Only)
7	532 12 49-59	Bearing Flange (Front Wheel Only)
8	532 17 50-39	Cap Axle Blk. 1 50 x 1 00
9	532 12 46-35	Tire Rear 18 x 8.5-8
10	532 12 49-26	Tube Rear (Service Item Only)
11	532 13 83-37	Rim Asm. 8" Rear
--	532 14 43-34	Sealant, Tire (10 oz. Tube)

NOTE: All component dimensions given in U.S. inches.
1 inch = 25.4 mm

TRACTOR - - MODEL NO. TS 138 (96041036702), PRODUCT NO. 960 41 03-67

SCHEMATIC **38**

SCH11

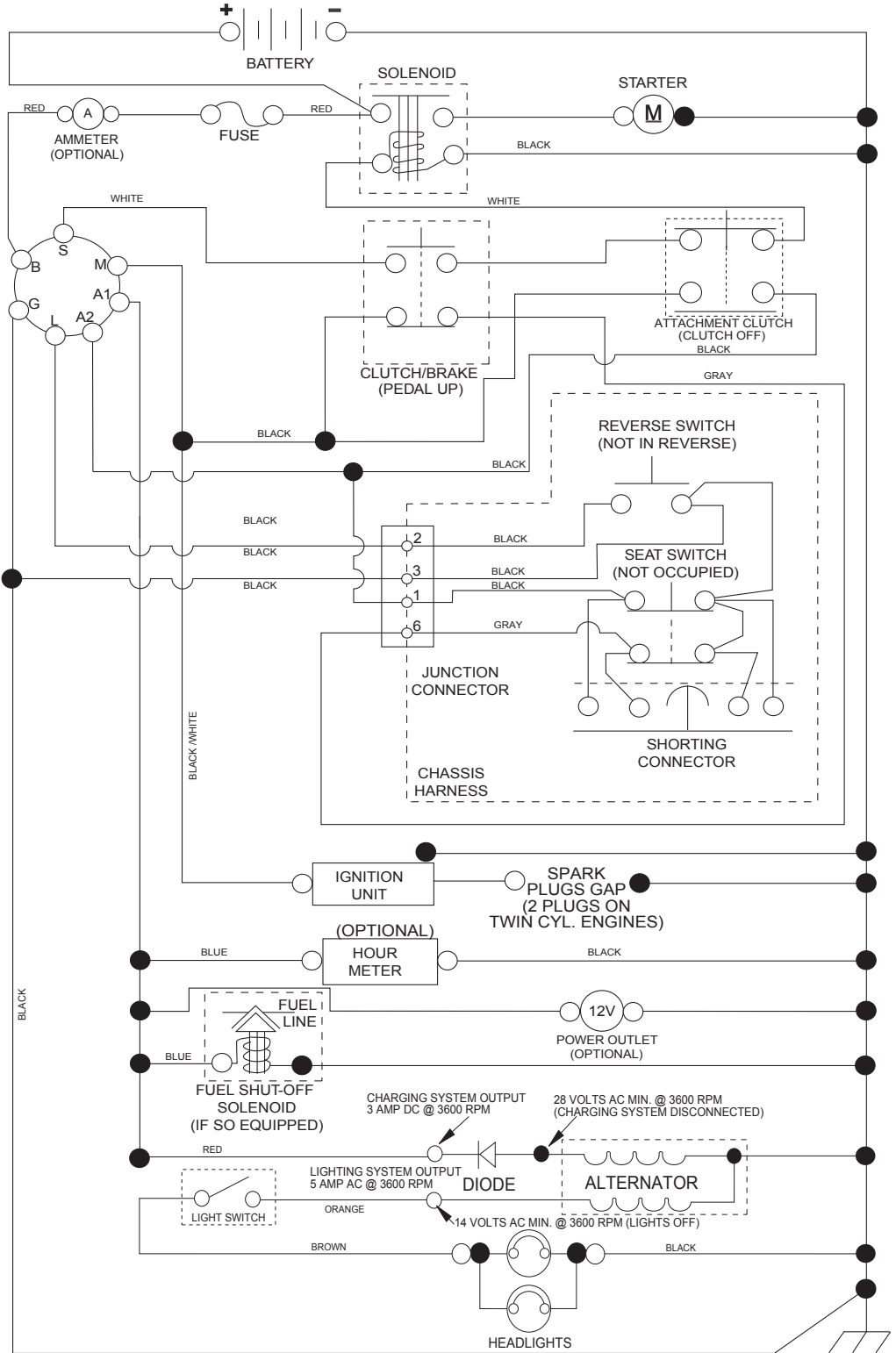

NOTE
YOUR TRACTOR IS EQUIPPED WITH A SPECIAL ALTERNATOR SYSTEM. THE LIGHTS ARE NOT CONNECTED TO THE BATTERY, BUT HAVE THEIR OWN ELECTRICAL SOURCE. BECAUSE OF THIS, THE BRIGHTNESS OF THE LIGHTS WILL CHANGE WITH ENGINE SPEED. AT IDLE THE LIGHTS WILL DIM. AS THE ENGINE IS SPEEDED UP, THE LIGHTS WILL BECOME THEIR BRIGHTEST.

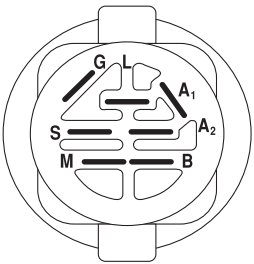

IGNITION SWITCH

POSITION	CIRCUIT	"MAKE"
OFF	M+G+A1	
RUN/OVERRIDE	B+A1	
RUN	B+A1	L+A2
START	B + S + A1	

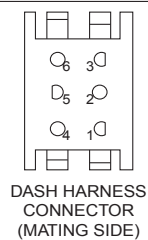
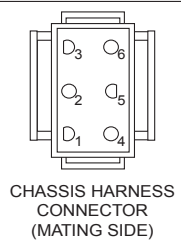

WIRING INSULATED CLIPS
NOTE: IF WIRING INSULATED CLIPS WERE REMOVED FOR SERVICING OF UNIT, THEY SHOULD BE RE-INSTALLED TO PROPERLY SECURE YOUR WIRING.

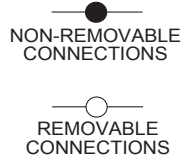

TRACTOR - - MODEL NO. TS 138 (96041036702), PRODUCT NO. 960 41 03-67
ELECTRICAL 32

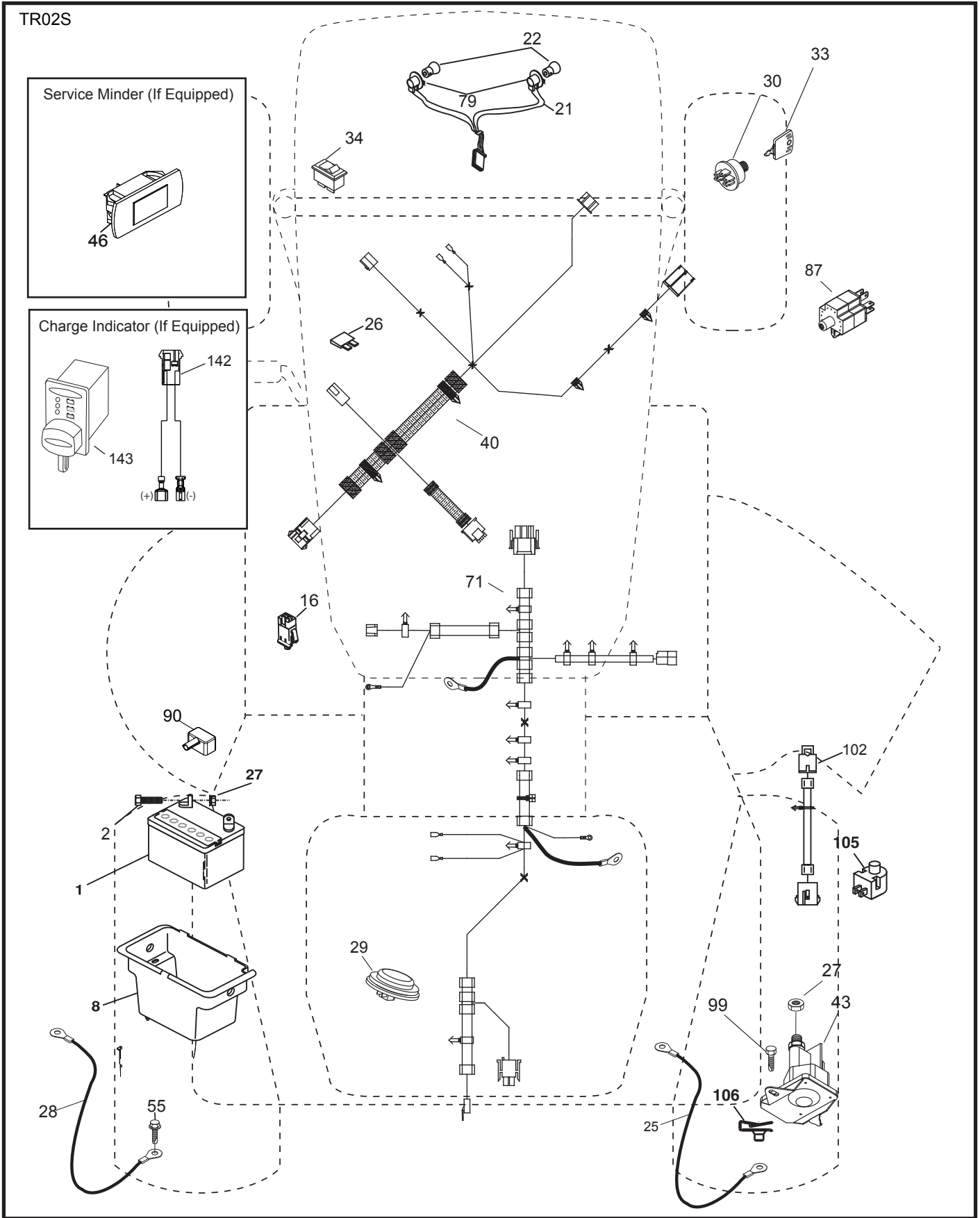

**TRACTOR - - MODEL NO. TS 138 (96041036702), PRODUCT NO. 960 41 03-67
ELECTRICAL 32**

KEY NO.	PART NO.	DESCRIPTION
1	532 16 34-65	Battery
2	874 76 04-12	Bolt Hex Head 1/4-20 x 3/4
8	532 19 32-28	Box Battery
16	532 17 61-38	Switch Interlock Push-In
21	532 40 02-52	Harness Socket Light w/4152J
22	532 00 41-52	Bulb Light
25	581 49 80-01	Cable Starter
26	532 17 51-58	Fuse
27	873 51 04-00	Nut Keps Hex 1/4-20 unc
28	532 42 16-86	Cable, Ground
29	532 40 15-45	Switch, Seat
30	532 19 33-50	Switch, Ign.
33	532 41 19-35	Key/Chain
34	532 11 07-12	Switch Light/Reset
40	585 55 52-01	Harness Ign. Dash
43	582 04 28-01	Solenoid
55	817 06 05-12	Screw Thdrol. 5/16-18 x 3/4 TYTT
71	501 13 37-01	Harness Chassis
79	532 17 52-42	Socket Asm. Bulb Twistlock
87	532 19 78-02	Switch Interlock Clutch Cable
90	532 43 53-95	Cover Terminal
99	817 67 04-12	Screw 1/4-20 x 3/4
102	581 02 34-01	Harness Pigtail
105	532 40 75-68	Switch Reverse
106	532 17 48-14	Palnut 1/4 Lugs
142	583 85 78-01	Charge Port Pigtail
143	532 44 80-59	Charge Port

NOTE: All component dimensions given in U.S. inches.
1 inch = 25.4 mm

**TRACTOR - - MODEL NO. TS 138 (96041036702), PRODUCT NO. 960 41 03-67
CHASSIS AND ENCLOSURES 39**

KEY NO.	PART NO.	DESCRIPTION	KEY NO.	PART NO.	DESCRIPTION
3	581 05 63-01	Logo	196	532 43 96-47	Console Asm. Deck Lift
5	585 47 79-06	Dash	201	819 13 20-16	Washer 13/32 x 1-1/4 x 16 Ga.
14	532 44 12-67	Hood	202	532 44 13-42	Vent Side Hood RH
15	532 44 14-28	Lens LH	203	532 44 13-43	Vent Side Hood LH
18	532 44 13-68	Grille	204	532 44 13-75	Vent Top Hood
25	532 44 14-27	Lens RH	205	532 44 13-44	Skirt Side RH
34	580 91 08-01	Plate Engine	206	532 44 13-45	Skirt Side LH
36	817 06 05-12	Screw 5/16-18 x 3/4	213	874 76 05-12	Bolt 5/16-18 unc x 3/4
37	532 44 12-06	Fender	214	532 19 91-45	Clip Retainer
52	873 68 05-00	Nut Crown Lock 5/16-18	217	532 40 91-67	Rod Pivot Hood
58	532 41 22-80	Drawbar Upper	218	532 19 63-95	X-Piece Hood Stop
68	817 49 05-08	Screw Thdrol. 5/16-18 x 1/2	228	532 19 51-61	Stud Fastener
130	532 41 63-58	Screw #10 x 0.750 BOS Thread	235	532 40 61-29	Spacer Fender
137	532 40 75-90	Bumper Dash	236	873 93 05-00	Nut Lock 5/16-18 unc
138	532 43 97-47	Cupholder	238	532 44 13-74	Trim
150	532 40 66-62	Air Duct	239	532 40 48-83	Clip Tinnerman
151	532 40 78-07	Bracket Pivot	287	817 60 04-06	Screw Hex WASHEAD 1/4-20 x 3/8
152	532 19 95-35	Shield Browning	297	532 40 66-65	Insert Reflective LH
159	817 00 06-12	Screw 3/8 - 16 x 3/4	303	587 49 34-02	Shield Chassis French LH
162	532 14 24-32	Screw Hex Wsh. Hi-Lo 1/4 x 1/2	304	587 86 51-02	Shield Chassis French RH
175	532 19 94-72	Crossmember	307	587 49 46-01	Shield Upper Pedal
176	532 40 07-76	Screw 10-24 x 5/8	308	532 17 18-77	Bolt 5/16-18 unc x 3/4
177	532 19 52-28	Bushing Steering	312	587 49 30-02	Shield Drawbar French
180	532 41 50-63	Chassis	375	586 90 82-01	Dash Clip-On Bumper
181	532 43 97-46	Bushing Mtg. Fender Cargo	376	589 45 87-01	Mount Asm. Husq LT Upper Strng
182	532 40 71-76	Dash Lower	377	589 45 53-01	Screw 10 x 1/2 ZN PL Phil Pan AB
183	874 52 05-20	Bolt 5/16-18 unc x 1-1/4			
184	587 55 41-01	Plug			
189	817 00 05-12	Screw 5/16-18 x 3/4			
191	532 41 65-01	Insert Reflective RH			
194	873 90 05-00	Nut Lock Hex Flange 5/16-18			
195	532 43 99-76	Plug Dash			

NOTE: All component dimensions given in U.S. inches.
1 inch = 25.4 mm

TRACTOR - - MODEL NO. TS 138 (96041036702), PRODUCT NO. 960 41 03-67
DRIVE **40**

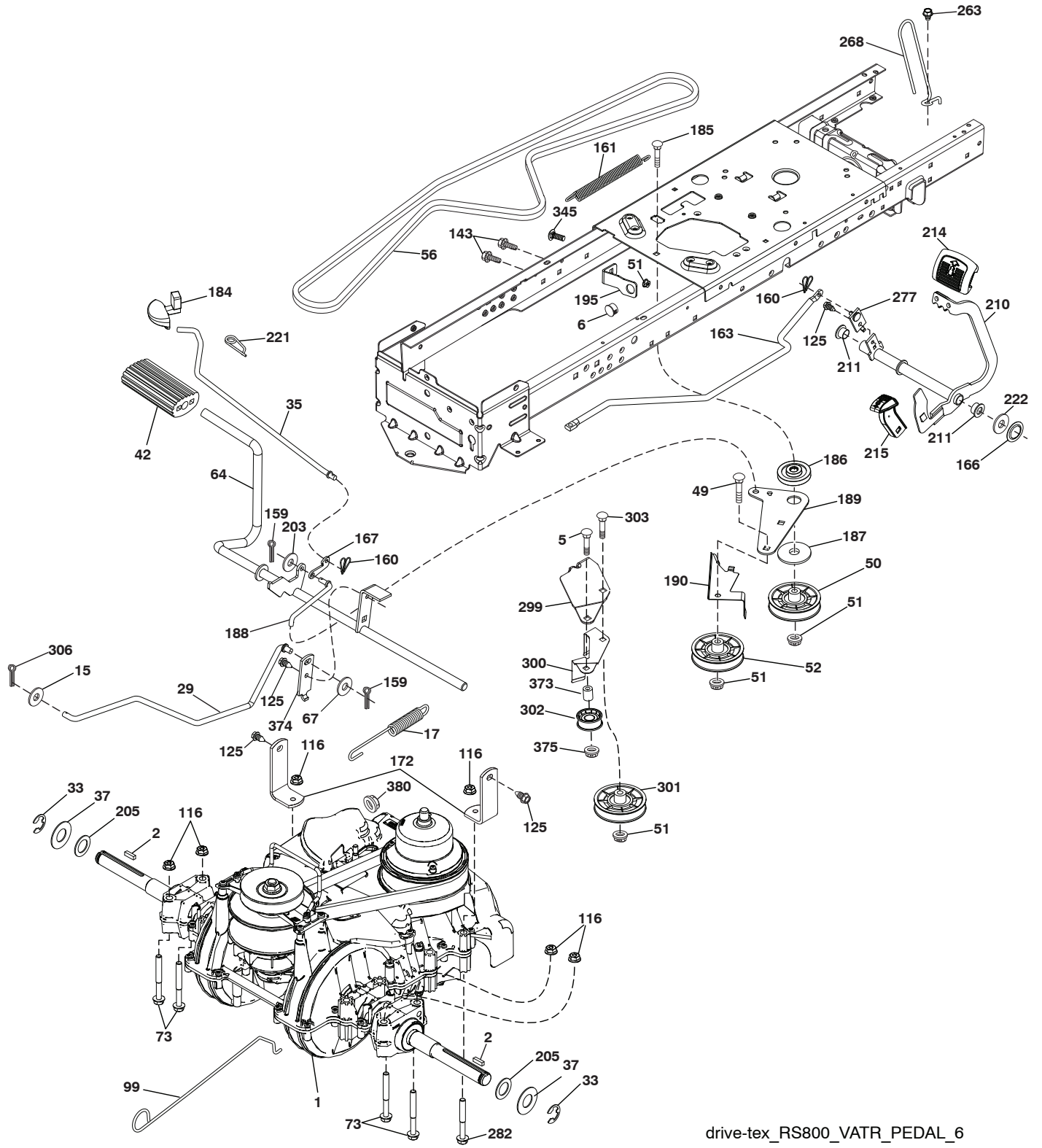

drive-tex_RS800_VATR_PEDAL_6

**TRACTOR - - MODEL NO. TS 138 (96041036702), PRODUCT NO. 960 41 03-67
DRIVE **40****

KEY NO.	PART NO.	DESCRIPTION	KEY NO.	PART NO.	DESCRIPTION
1	---	Transaxle, Variator SD Pedal (590277501) (Order parts from transaxle manufacturer.)	186	532 19 43-21	Spacer Retainer
2	532 12 35-83	Key Square	187	819 13 32-10	Washer 13/32 x 2 x 10 ga
5	874 76 06-36	Bolt Hex HS 3/8-16 unc x 2-1/4	188	582 21 70-01	Link Clutch Ground Drive, Long
6	532 12 40-28	Bushing Snap	189	532 19 43-17	Bellcrank Ground Drive
15	819 13 13-16	Washer 13/32 x 13/16 x 16 Ga.	190	532 19 43-18	Keeper. Bellcrank
17	501 48 71-01	Spring, Brake	195	581 50 46-01	Bracket Brake
29	584 82 31-01	Rod, Brake	203	819 11 11-16	Washer 11/32 x 11/16 x 16
33	812 00 00-01	Ring E	205	532 12 17-48	Washer 25/32 x 1-5/8 16 Ga.
35	532 40 10-31	Rod, Brake, Park	210	588 92 10-01	Weldment Pedal VATR
37	532 18 89-67	Washer .793 x 1.637 x 060	214	532 42 12-63	Pedal Forward
42	532 12 48-72	Cover, Foot Pedal	215	591 10 01-01	Pad Pedal Reverse
49	872 11 06-14	Bolt 3/8-16 unc	211	532 12 01-83	Bearing Nylon
50	532 19 43-27	Idler Flat	221	532 40 31-87	Retainer Spring
51	873 90 06-00	Nut Lock	222	879 21 20-10	Washer Flat
52	532 19 43-26	Idler V-Groove	263	817 00 06-12	Screw
56	581 60 38-01	V-Belt, Drive	268	532 18 24-02	Guard.Muffler
64	589 67 14-01	Subasm. Shaft Pedal Brake	277	532 44 85-00	Subasm. Link Rocker Pedal
67	582 58 01-01	Washer Nylon 13/32 x 13/16 x .109	282	874 49 05-48	Bolt Hex 5/16-18x
73	874 49 05-44	Bolt Hex 5/16-18 x 3.75	299	532 41 56-83	Bracket Mount
99	532 43 59-35	Rod Bypass	300	532 41 56-81	Keeper Idler
116	873 90 05-00	Nut Lock Hex Flange 5/16-18	301	532 41 56-80	Pulley Idler Groove
125	817 00 05-12	Screw 5/16-18 x 3/4	302	581 42 05-01	Puller Idler Flat
143	817 49 05-08	Screw Thdrol 5/16-18 x 1/2 TYTT	303	872 11 06-18	Bolt
159	876 02 04-12	Pin Cotter 1/8 x 3/4	306	876 02 04-16	Pin Cotter
160	532 16 94-84	Retainer Clip	345	872 11 06-06	Bolt RDHD
161	532 10 57-09	Spring, Return, Clutch	373	581 46 18-01	Spacer Idler
163	587 84 79-02	Rod Control	374	581 47 52-01	Arm Control Brake
166	532 42 91-64	Nut Push .625	375	873 68 06-00	Nut Crownlock 3/8-16 unc
167	532 40 52-57	Latch Brake Parking	380	582 47 86-01	Nut Flg Nylock 1/4-20 Gr G ZY
172	583 97 42-02	Strap Torque Variator			
184	532 41 14-84	Handle Park Brk.			
185	872 11 06-22	Bolt 3/8-16 unc x 2-3/4			

NOTE: All component dimensions given in U.S. inches.
1 inch = 25.4 mm

**TRACTOR - - MODEL NO. TS 138 (96041036702), PRODUCT NO. 960 41 03-67
ENGINE 24**

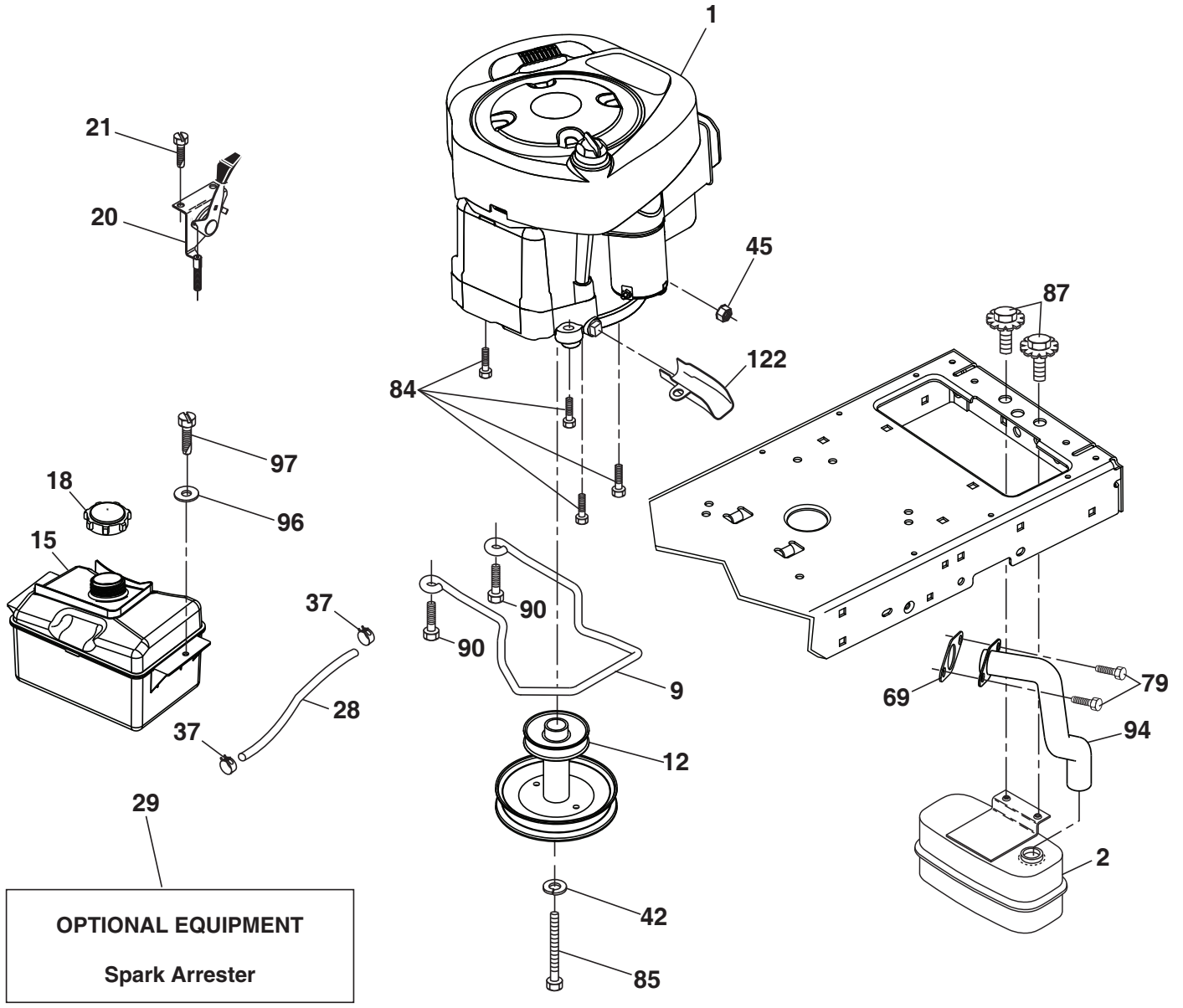

engine-tex_BS_119

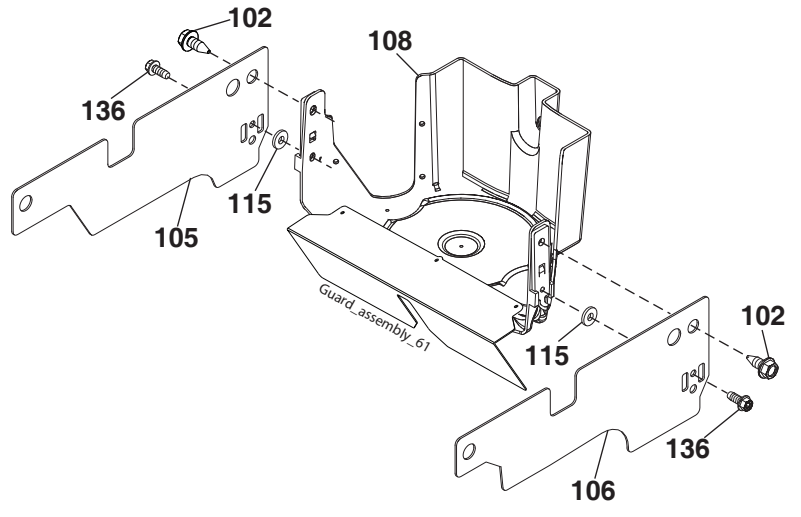

**TRACTOR - - MODEL NO. TS 138 (96041036702), PRODUCT NO. 960 41 03-67
ENGINE 24**

KEY NO.	PART NO.	DESCRIPTION
1	-----	Engine Briggs Model No. 31R577-0027-B1 (587333501) (Order parts from engine manufacturer.)
2	532 18 86-55	Muffler
9	501 83 26-02	Keeper Belt Engine
12	586 47 85-01	Pulley Engine
15	581 28 99-01	Tank Fuel
18	532 43 02-20	Cap Asm
20	587 24 26-01	Control Throttle
21	532 41 63-58	Screw #10 x 0.750 BOS Thread
28	532 13 70-40	Fuel Line
29	532 13 71-80	Spark Arrester Kit
37	532 12 34-87	Clamp Hose
42	539 99 02-47	Washer SLW STD 7/16
45	873 51 04-00	Nut Keps Hex 1/4-20 unc
69	532 16 52-91	Gasket
79	532 19 23-34	Screw 5/16-18 x 3/4
84	817 06 06-20	Screw 3/8-16 x 1/4
85	501 60 65-01	Bolt Hex 7/16-20 x Gr. 5-1.5
87	532 17 18-77	Bolt 5/16-18 unc x 3/4 w/Sems
90	817 00 06-16	Screw 3/8-16 x 1
94	581 88 09-01	Exhaust Tube
96	819 09 14-16	Washer 9/32 x 7/8 x 16 Ga.
97	817 67 04-12	Screw 1/4-20 x 3/4
102	817 00 05-12	Screw
105	501 26 72-02	Shield Side LH
106	501 26 82-02	Shield Side RH
108	587 17 95-01	Cover Eng. Pulley w/SHLD 38", 42"
115	532 43 17-61	Palnut #10
122	532 42 19-22	Extension Drain Oil
136	532 42 17-56	Screw, #10 0.500, BOS

NOTE: All component dimensions given in U.S. inches.
1 inch = 25.4 mm

Engine Power Rating Information

The gross power rating for individual gas engine models is labeled in accordance with SAE (Society of Automotive Engineers) code J1940 (Small Engine Power & Torque Rating Procedure), and rating performance has been obtained and corrected in accordance with SAE J1995 (Revision 2002-05). Torque values are derived at 3060 RPM; horsepower values are derived at 3600 RPM. Actual gross engine power will be lower and is affected by, among other things, ambient operating conditions and engine-to-engine variability. Given both the wide array of products on which engines are placed and the variety of environmental issues applicable to operating the equipment, the gas engine will not develop the rated gross power when used in a given piece of power equipment (actual "on-site" or net power). This difference is due to a variety of factors including, but not limited to, accessories (air cleaner, exhaust, charging, cooling, carburetor, fuel pump, etc.), application limitations, ambient operating conditions (temperature, humidity, altitude), and engine-to-engine variability. Due to manufacturing and capacity limitations, Briggs & Stratton may substitute an engine of higher rated power for this Series engine.

TRACTOR - - MODEL NO. TS 138 (96041036702), PRODUCT NO. 960 41 03-67
STEERING ASSEMBLY **41**

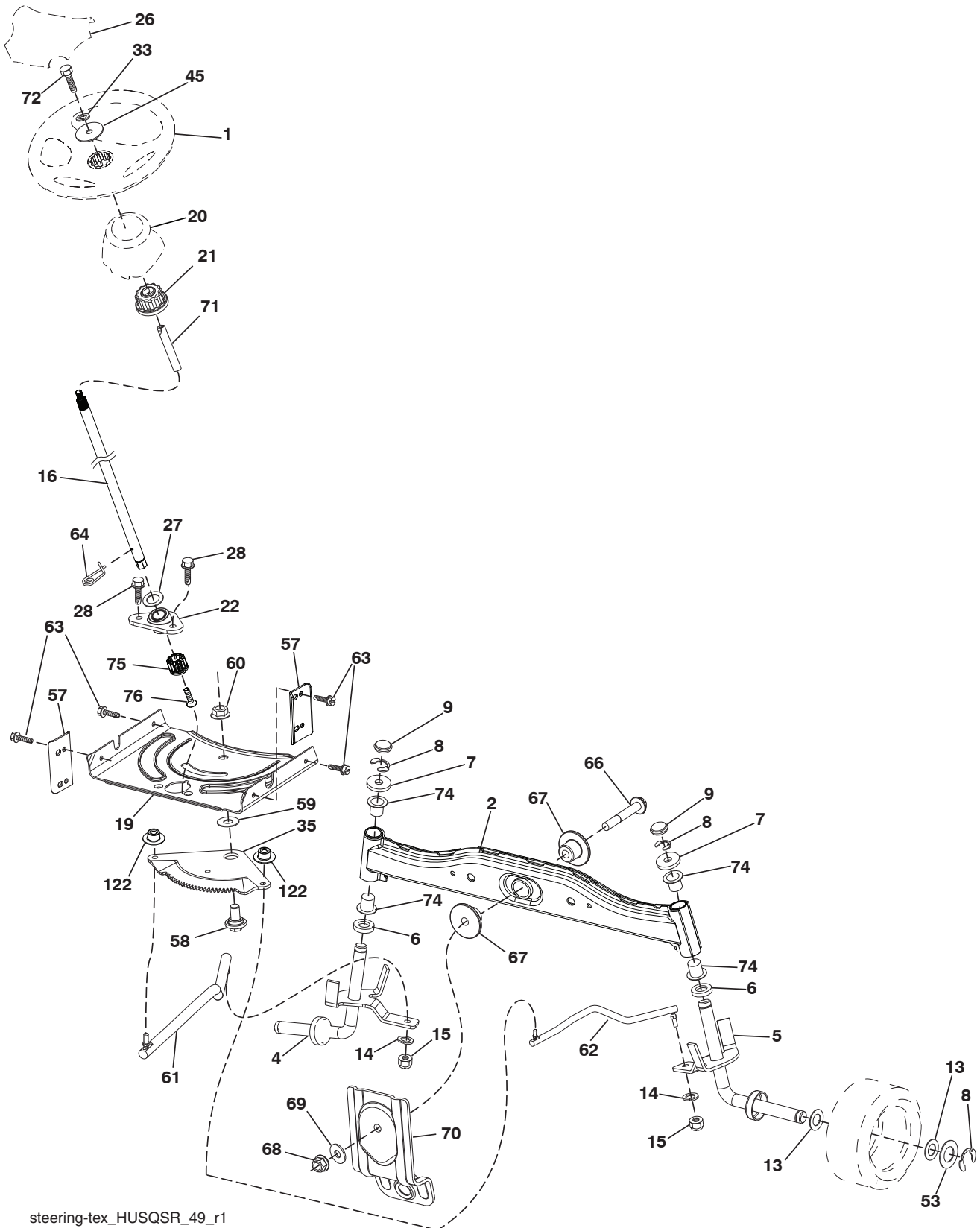

steering-tex_HUSQSR_49_r1

**TRACTOR - - MODEL NO. TS 138 (96041036702), PRODUCT NO. 960 41 03-67
STEERING ASSEMBLY 41**

KEY NO.	PART NO.	DESCRIPTION
1	532 43 99-97	Wheel, Steering Husq SR
2	532 41 81-68	Axle Asm., Front
4	532 40 30-87	Spindle Asm., LH
5	532 40 30-88	Spindle Asm., RH
6	532 12 49-31	Bearing, Race Thrust Hardened
7	532 12 17-48	Washer 25/32 x 1-5/8 x 16 Ga.
8	812 00 00-29	Ring, Clip #T5304-75
9	532 12 12-32	Cap, Spindle
13	532 12 17-49	Washer 25/32 x 1-1/4 x 16 Ga.
14	539 99 01-18	Washer, SLW ZD 3/8
15	873 54 06-00	Nut, Crown Lock 3/8-24 unf
16	585 86 92-02	Steering Shaft
19	532 19 47-29	Plate Steering
20	532 44 14-25	Boot, Steering
21	532 18 67-37	Adapter, Wheel Steering
22	585 02 98-02	Bearing
26	532 43 97-43	Insert, Wheel Steering Husq SR
27	819 21 16-16	Washer 21 x 32 x 1 x 16 Ga.
28	817 00 06-12	Screw 3/8-16 x 3/4
33	539 -99 01-87	Washer Lock 5/16
35	532 19 47-32	Gear, Sector Plate
45	819 11 38-12	Washer 11/32 x 3/8 x 12 Ga.
53	532 18 89-67	Washer Hardened .793 x 1.637 x .060
57	532 40 74-65	Bracket Upstop
58	532 19 47-47	Bolt Shoulder Sector Pivot CFM
59	532 19 47-48	Washer Thrust Sector Steering
60	873 97 10-00	Nut Flange Lock 5/8-11
61	532 19 47-40	Draglink, LH
62	532 19 47-41	Draglink, RH
63	817 00 05-12	Screw 5/16-18 x 3/4
64	532 19 98-49	Retainer Clip Spring Steering
66	871 02 07-48	Bolt Hex Fghd. 7/16-14 x 3 Serr.
67	532 19 47-37	Bushing PM Front Axle
68	873 90 07-00	Nut Lock Flange 7/16-14 Gr. 5
69	532 19 91-62	Washer 1.5 x .505 x .118
70	585 33 88-01	Bracket Deck Susp. Front
71	532 19 07-52	Shaft Extension Steering
72	532 42 89-82	Bolt Fin Hx 5/16-18 x 4 w/Patch
74	532 12 49-37	Bearing Col. STRG
75	580 68 37-01	Pinion
76	580 68 36-01	Screw Head Sock
122	532 44 49-62	Cap Gear Sector

NOTE: All component dimensions given in U.S. inches.
1 inch = 25.4 mm

TRACTOR - - MODEL NO. TS 138 (96041036702), PRODUCT NO. 960 41 03-67
MOWER DECK 44

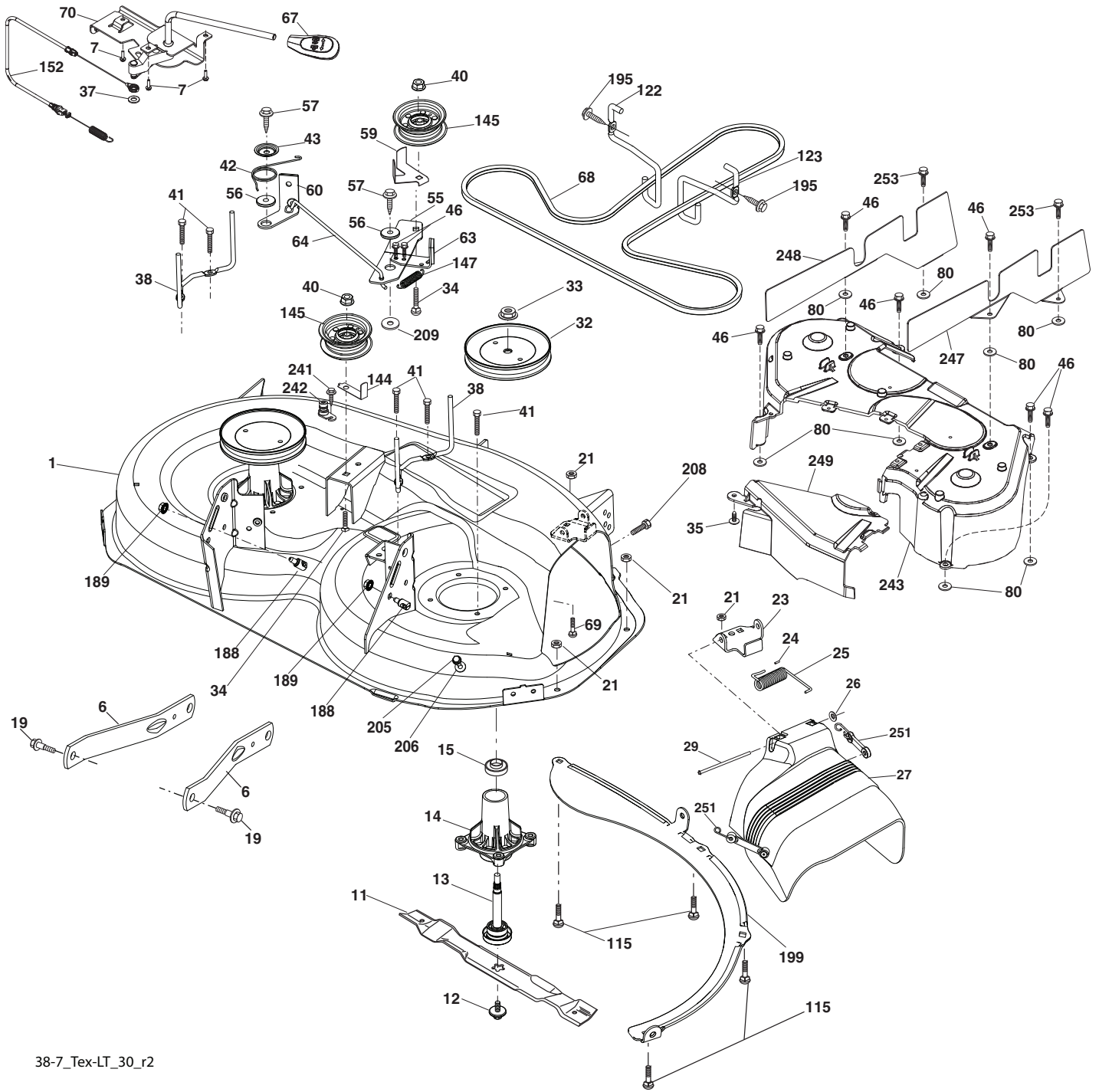

38-7_Tex-LT_30_r2

TRACTOR - - MODEL NO. TS 138 (96041036702), PRODUCT NO. 960 41 03-67
MOWER DECK 44

KEY PART NO. NO.	DESCRIPTION	KEY PART NO. NO.	DESCRIPTION
1	587 77 18-02	70	532 40 12-46
6	532 19 51-86	80	532 42 30-62
7	532 41 63-58	115	872 11 05-05
11	581 11 63-01	122	532 19 72-58
12	584 30 93-01	123	532 19 72-59
13	587 25 65-01	144	532 19 34-14
14	532 18 72-81	145	532 19 31-97
15	585 32 39-01	147	532 40 18-72
19	532 19 65-39	152	532 43 51-11
21	873 68 05-00	188	532 19 51-61
23	532 19 25-57	189	873 90 05-00
24	532 10 53-04	195	817 00 06-12
25	532 19 70-26	199	532 40 00-95
26	532 11 04-52	205	817 49 04-16
27	532 40 16-18	206	819 09 14-16
29	532 13 14-91	208	817 67 06-08
32	532 19 97-89	209	819 13 32-10
33	532 40 02-34	241	532 15 29-27
34	872 11 06-12	242	532 41 55-98
35	532 13 38-35	243	532 40 65-10
37	819 13 13-16	247	532 43 02-58
38	532 19 95-41	248	532 43 02-59
40	873 90 06-00	249	532 40 65-14
41	584 95 39-01	251	532 43 60-87
42	532 19 84-10		
43	532 19 72-56	253	532 42 73-50
46	532 13 77-29	--	587 25 33-01
55	532 19 72-49		
56	532 19 90-92		
57	817 00 06-16		
59	532 14 10-43		
60	532 19 94-71		
63	532 19 94-70	--	532 44 33-58
64	532 19 97-90		
67	532 40 30-12		
68	532 40 83-81		
69	872 14 05-05		

NOTE: All component dimensions given in U.S. inches.
1 inch = 25.4 mm

TRACTOR - - MODEL NO. TS 138 (96041036702), PRODUCT NO. 960 41 03-67
MOWER LIFT 45

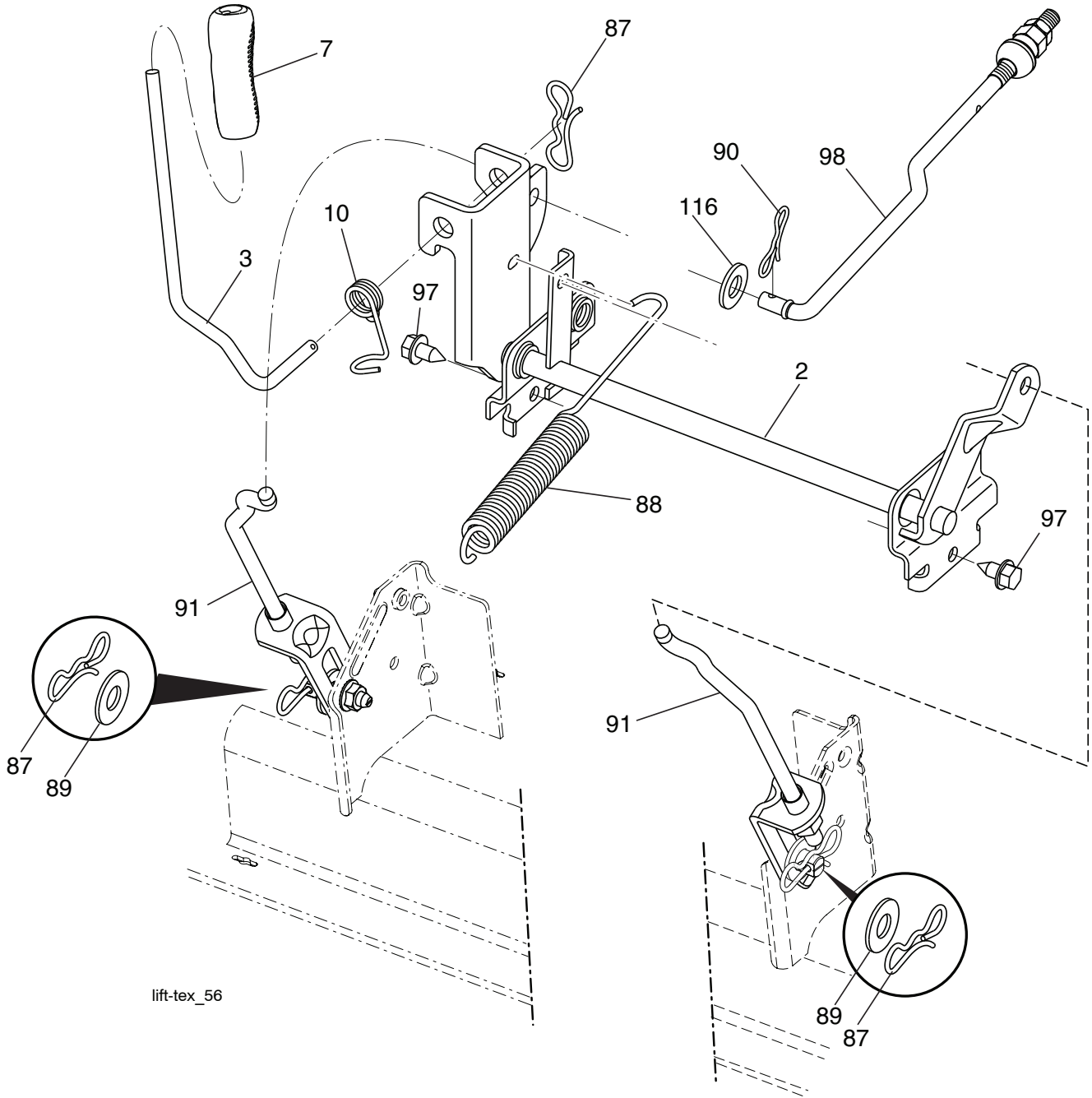

KEY NO.	PART NO.	DESCRIPTION
2	532 42 20-27	Shaft Asm., Lift
3	532 19 52-31	Lever Asm., Lift RH
7	580 96 23-01	Grip, Lever
10	532 19 63-14	Spring Torsion
87	532 19 42-09	Pin Cotter 7/16 Bow Tie Lock
88	532 41-07-10	Spring Lift Assist
89	819 19 19-12	Washer Clear Zinc
90	532 19 42-08	Pin Cotter 5/16 Bow Tie Lock

KEY NO.	PART NO.	DESCRIPTION
91	532 19 51-81	Link Lift Susp. Mower Rear
97	817 00 06-12	Screw 3/8-16 x .75 Smgml. Tap/R.Z
98	532 19 52-70	Link Lift Susp. Front Mower
116	819 15 15-16	Washer 15/32 x 15/16 x 16 Ga.

NOTE: All component dimensions given in U.S. inches.
 1 inch = 25.4 mm

**TRACTOR - - MODEL NO. TS 138 (96041036702), PRODUCT NO. 960 41 03-67
SEAT ASSEMBLY 42**

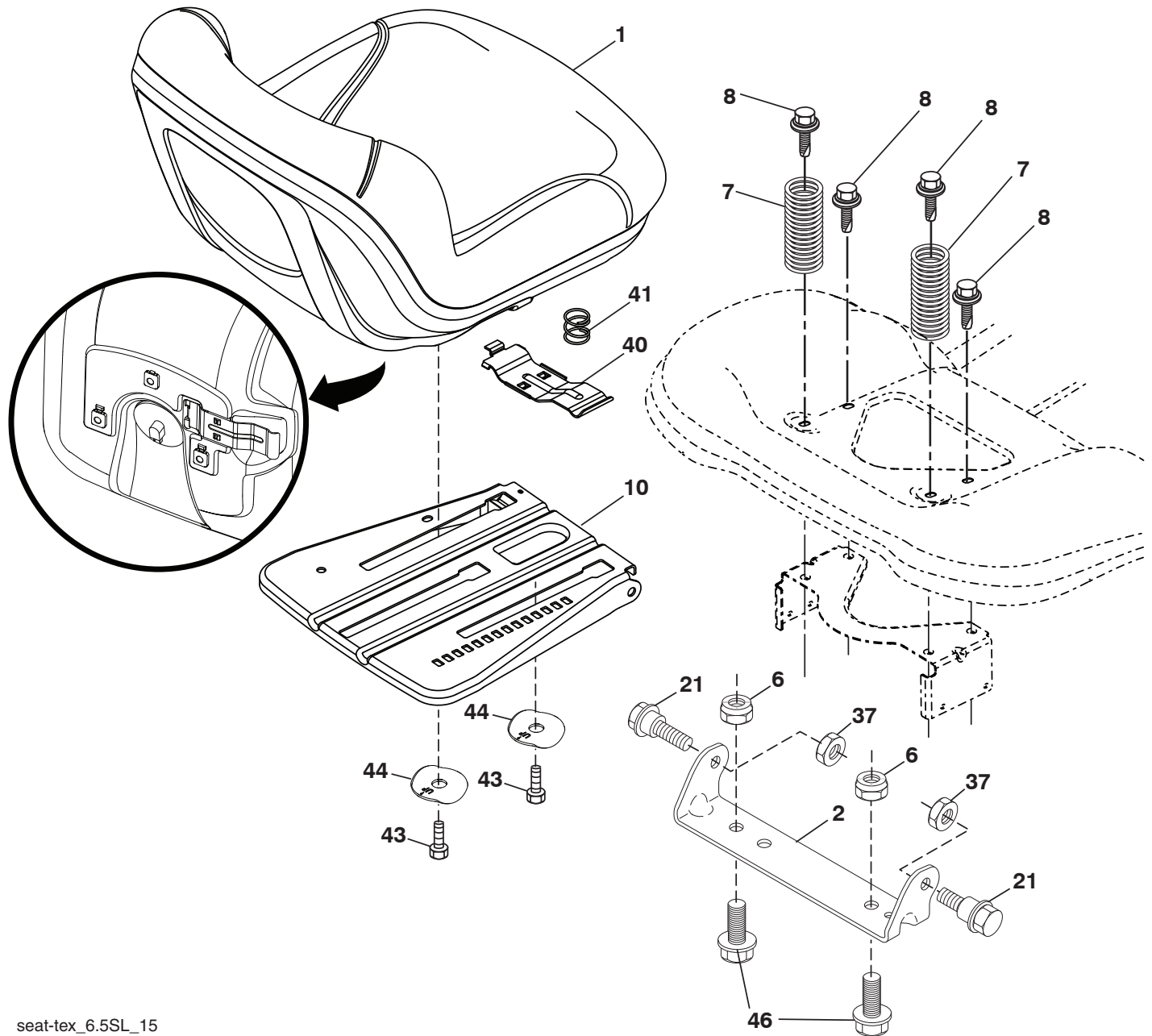

seat-tex_6.5SL_15

KEY NO.	PART NO.	DESCRIPTION
1	532 43 97-09	Seat
2	532 18 01-66	Bracket Pivot Fender
6	873 80 06-00	Nut, Lock w/Ins. 3/8-16 unc
7	589 48 35-01	Spring, Seat Cprsn.
8	532 17 18-77	Bolt 5/16-18 unc x 3/4 w/Sems.
10	587 23 20-02	Pan, Seat
21	587 90 78-01	Bolt, Shoulder 5/16-18 x 5/8
37	873 80 05-00	Nut, Lock 5/16-18 unc
40	532 19 76-61	Handle

KEY NO.	PART NO.	DESCRIPTION
41	532 19 82-00	Spring
43	874 76 06-12	Bolt 3/8-16 unc x 3/4
44	501 05 18-01	Washer Winged
46	588 09 04-01	Bolt 3/8-16 X 1, 1.25 OD

NOTE: All component dimensions given in U.S. inches.
1 inch = 25.4 mm

