



Parts Manual

Zero Turn Mower / Z 246

967 665401-00

Please read the operator manual carefully and make sure you understand the instructions before using the machine.



When you need spare parts or support in service questions, warranty issues, etc., please consult the following professional:

This manual belongs to the machine with the manufacturing number:	Engine	Transmission

Manufacturing Number

The machine's manufacturing number can be found on the printed plate affixed to the engine compartment.

Stated on the plate, from the top are:

- The machine's type designation (I.D.).
- The manufacturer's type number (Model).
- The machine's serial number (Serial no.)

Please have the type designation and serial number available when ordering spare parts.

CONTENTS

FRAME	4
ENGINE MOUNTING, GUARDS & MUFFLER	6
STEERING	8
IGNITION SYSTEM.....	10
BRAKE / LIFT	12
HYDRAULIC PUMP-MOTOR.....	14
WHEELS & TIRES	16
MOWER DECK / CUTTING DECK	18
SEAT	20
DECALS	22

Illustrations may or may not represent the actual assemblies and it is not recommended to use this manual as a guide to assemble or disassemble the mower.

NOTE: All fasteners are Grade 5 unless otherwise specified.

FRAME

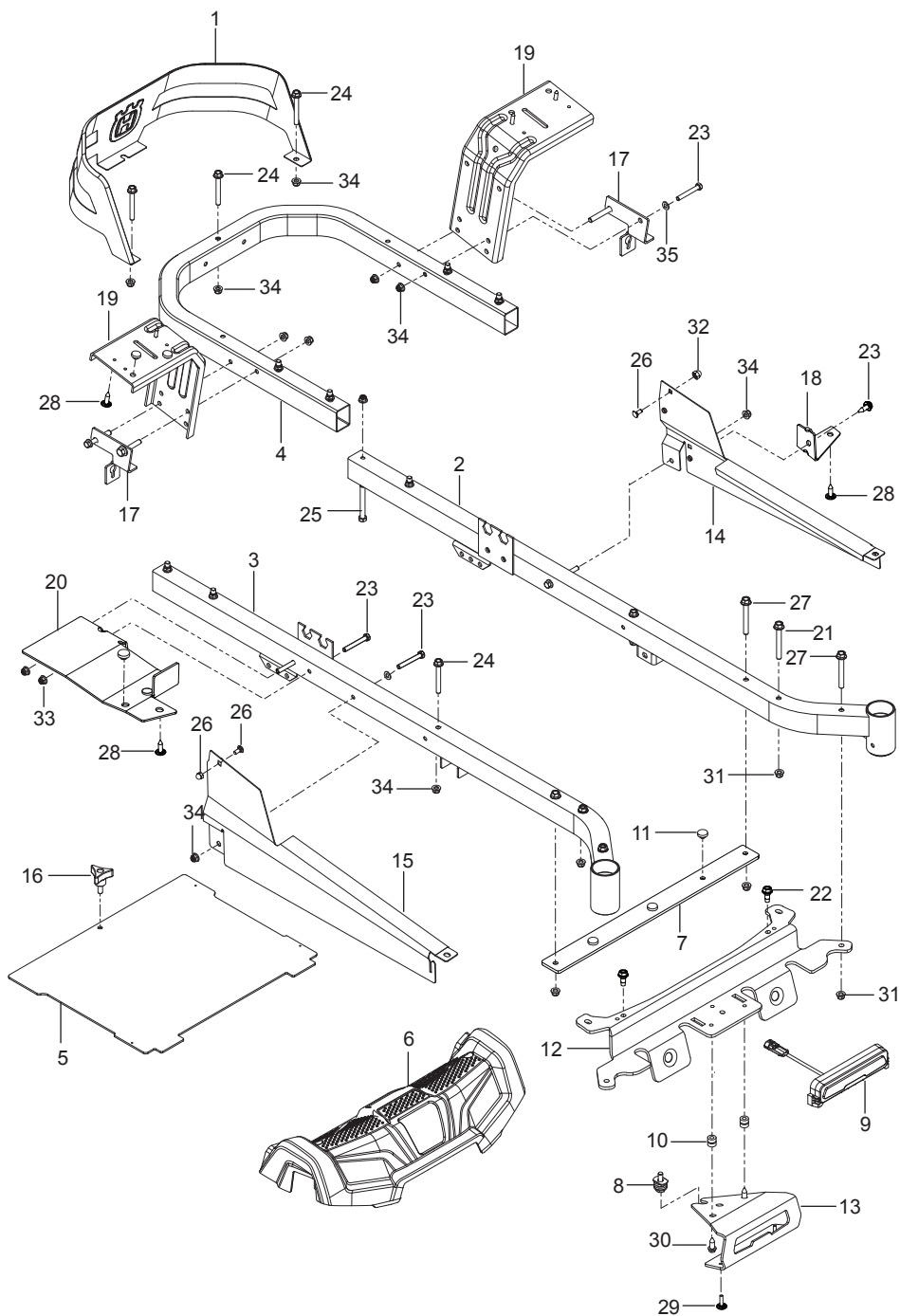

Ref.	Part No.	Qty	Description
1	585 03 98-02	1	Guard, Rear Blk
2	589 28 34-02	1	Frame, Front Right Orange
3	589 28 33-02	1	Frame, Front Left Orange
4	584 99 10-02	1	Frame, Rear Tube Orange
5	522 84 29-02	1	Foot Plate w/ Safety Decal
6	586 70 38-01	1	Cover, Footrest w/Decal
7	585 52 30-04	1	Support, Footrest
8	587 54 69-01	1	Assembly, Isolator Tap
9	585 91 67-01	1	Assembly, Led Light
10	587 22 52-01	2	Grommet, Push
11	585 98 93-01	7	Grommet, Bumper
12	585 52 31-04	1	Cross Member
13	587 45 86-02	1	Bracket, Light
14	585 33 16-02	1	Cover, Rail Right
15	585 33 15-02	1	Cover, Rail Left
16	539 10 44-11	1	Knob w/ Stud
17	585 47 43-02	2	Bracket, Bypass Rod
18	585 52 36-04	1	Support, Console Left
19	580 50 13-02	2	Support, Fender Blk
20	585 52 34-04	1	Support, Console Right
21	586 65 43-01	2	Bolt 3/8-16 x 3 Shoulder
22	586 88 11-01	2	Bolt 5/16-18 Shoulder
23	874 78 05-36	7	Bolt 5/16-18 x 2-1/4
24	874 78 05-44	5	Bolt 5/16-18 x 2-3/4
25	874 78 06-48	8	Bolt 3/8-16 x 3
26	585 94 00-01	2	Bolt 5/16-18 x 1 Carriage
27	577 11 77-01	4	Bolt 3/8-16 x 3
28	532 41 63-58	6	Screw #10-24 x 3/4 Hex Head
29	532 42 17-56	2	Screw #10 x 1/2
30	817 58 05-20	2	Screw 5/16-18 x 1-1/4 Washer Head
31	521 99 65-01	8	Nut 3/8-16 Hex Flange Nyloc
32	585 93 81-01	2	Nut 5/16-18 Acorn
33	873 90 05-00	2	Nut 5/16-18 Hex Flange Lock
34	539 11 28-99	9	Nut 5/16-18 Hex Flange Nyloc
35	819 11 11-16	6	Washer 5/16 SAE Flat

ENGINE MOUNTING, GUARDS & MUFFLER

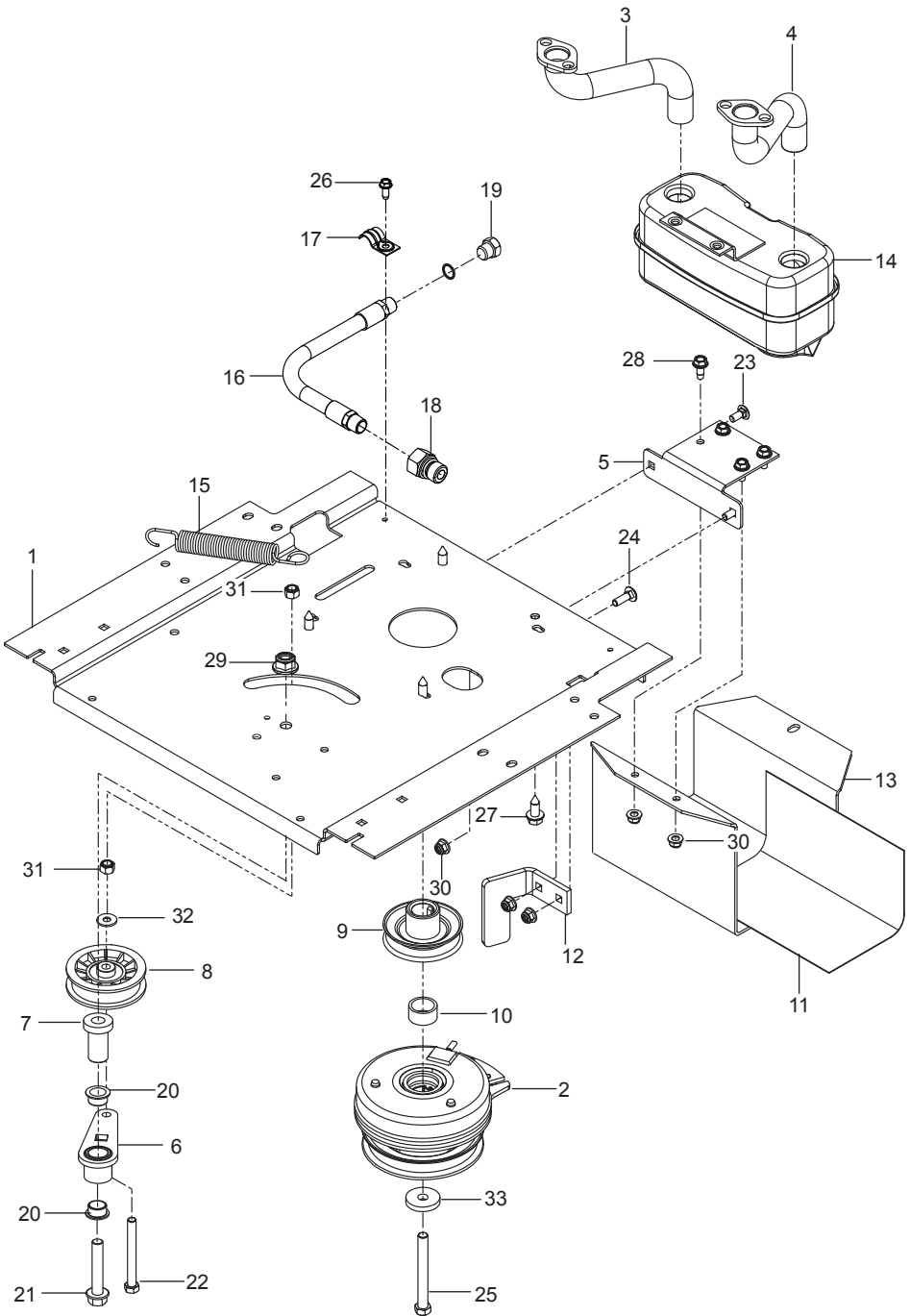

Ref.	Part No.	Qty	Description
1	588 01 71-02	1	Plate, Engine Blk
2	585 52 11-01	1	Clutch
3	583 95 57-01	1	Tube, Exhaust Right
4	583 95 56-01	1	Tube, Exhaust Left
5	581 88 67-02	1	Bracket, Muffler Blk
6	532 44 81-45	1	Arm, Idler
7	582 53 89-01	1	Spindle, Idler
8	539 11 03-11	1	Pulley, Idler
9	587 53 74-01	1	Pulley, Engine
10	539 11 22-52	1	Spacer
11	539 13 28-59	1	Shield, Muffler
12	510 24 60-02	1	Stop, Clutch Blk
13	587 45 12-02	1	Guard, Muffler Blk
14	539 13 16-04	1	Muffler Assembly
15	532 19 61-05	1	Spring, Deck Drive
16	584 82 55-01	2	Assy, Drain Hose
17	539 10 13-63	1	Clamp
18	522 59 90-01	1	Adapter, Oil Drain
19	585 80 71-01	1	Plug, Oil
20	501 60 37-01	2	Bearing, Flanged
21	582 53 95-01	1	Bolt 1/2-13 x 2-3/4 Hex Flange Head
22	874 52 06-56	1	Bolt 3/8-16 x 3-1/2 Hex Head
23	872 14 05-06	2	Bolt 5/16-18 x 1 Round Head Square Neck
24	872 14 05-08	2	Bolt 5/16-18 x 3/4 Round Head Square Neck
25	581 33 28-04	1	Bolt 7/16-20 x 3-1/2 Hex Head
26	817 49 04-10	1	Screw 1/4-20 X 5/8 Thread Form
27	817 12 06-16	4	Screw 3/8-16 x 1 Thread Form
28	817 49 05-12	4	Screw 5/16-18 x 3/4 Thread Form
29	521 99 11-01	1	Nut 1/2-13 Hex Flange Nyloc
30	539 11 28-99	5	Nut 5/16-18 Hex Flange Nyloc
31	539 97 69-79	2	Nut 3/8-16 Hex Nyloc
32	819 12 14-14	2	Washer 5/16 Std Flat
33	532 12 61-97	1	Washer, Clutch
	NOT SHOWN		
	-----	1	Engine, Kawasaki FR600V 18 HP For Engine Replacement Parts, See a Kawasaki Dealer

STEERING

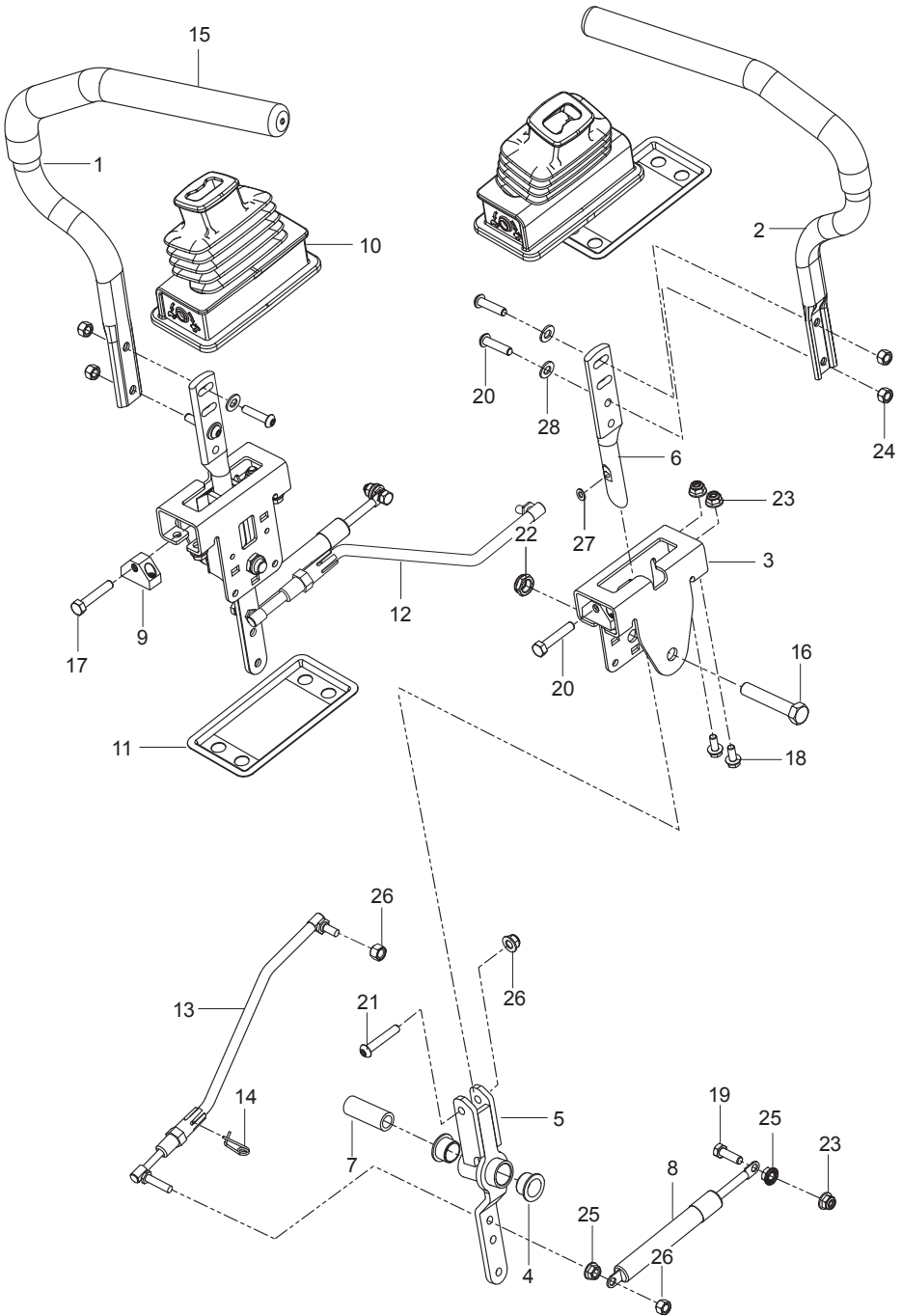

Ref.	Part No.	Qty	Description
1	582 31 38-03	1	Lever w/ Grip Right Blk
2	582 31 38-04	1	Lever w/ Grip Left Blk
3	585 12 47-05	2	Bracket, Control
4	539 13 15-18	4	Bearing, Flanged
5	576 14 03-01	2	Control, Lever
6	587 60 17-02	2	Lever, Handle
7	584 92 72-01	2	Spacer, Pivot Control
8	539 10 27-20	2	Dampener
9	581 43 75-01	2	Block, Tracking
10	585 83 16-01	2	Boot, Steering
11	585 48 82-02	2	Flange, Boot
12	588 60 49-01	2	Assy, Right Control Linkage
13	588 60 50-01	2	Assy, Left Control Linkage
14	532 19 98-49	2	Clip, Spring
15	525 39 29-02	2	Grip, Foam
16	874 78 08-44	2	Bolt 1/2-13 x 2-3/4 Hex Head
17	585 98 61-01	2	Bolt 5/16-18 x 1-1/4 Hex Head
18	874 49 05-12	8	Bolt Hex Flange 5/16-18 x 3/4
19	539 99 02-09	4	Bolt 5/16-18 X 1 Hex Head
20	585 98 59-01	4	Screw 5/16-18 x 1-1/4 Button Head Blk
21	587 88 53-01	2	Screw 5/16-18 x 1-3/4 Button Head
22	539 10 80-10	2	Nut 1/2-13 Hex Jam Nyloc Grade 2
23	539 11 28-99	10	Nut 5/16-18 Hex Flange Nyloc
24	585 98 60-01	4	Nut 5/16-18 Hex Nyloc Blk
25	539 99 05-85	4	Nut 5/16-18 Hex Whiz Lock
26	873 80 05-00	8	Nut 5/16-18 Hex Nyloc
27	587 61 42-01	2	Washer 11/32
28	586 30 91-01	4	Washer 5/16 SAE Flat Blk

IGNITION SYSTEM

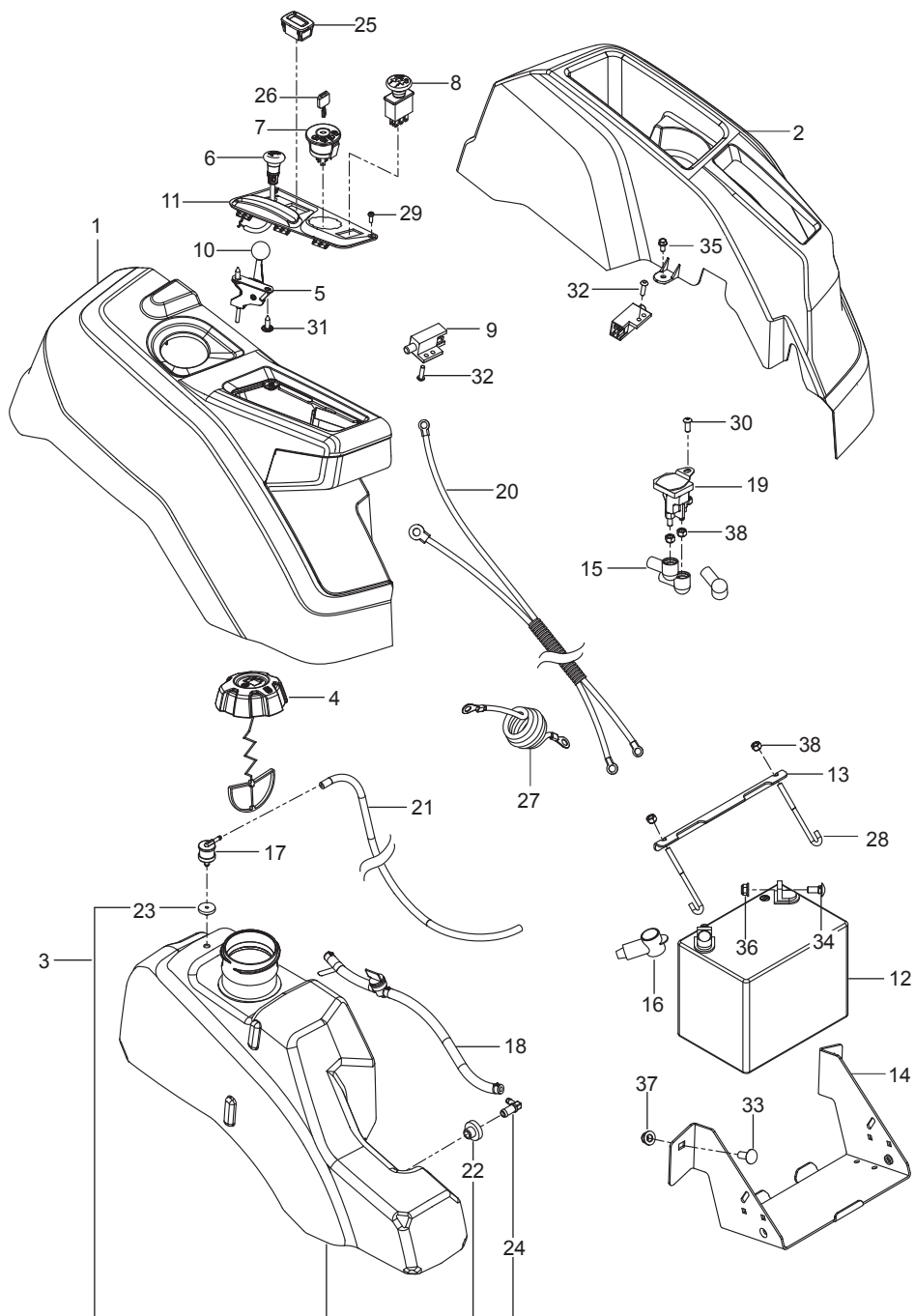

Ref.	Part No.	Qty	Description
1	585 52 28-01	1	Assembly, Fender, Right Gry
2	586 62 12 01	1	Assembly, Fender, Left Gry
3	589 92 47-01	1	Assembly, Fuel Tank
4	585 12 48-01	1	Cap, Fuel w/ Tether
5	539 11 24-38	1	Cable, Throttle
6	586 88 15-01	1	Control, Choke
7	539 10 75-41	1	Switch, Ignition
8	582 10 76-02	1	Switch, Clutch
9	587 60 15-01	2	Switch, Interlock
10	539 13 30-49	1	Knob
11	585 52 27-01	1	Panel, Control
12	539 10 24-36	1	Battery
13	510 03 00-03	1	Bracket, Battery
14	582 60 96-02	1	Box, Battery Blk
15	532 13 15-63	3	Terminal Cover
16	539 10 27-59	1	Terminal Cover
17	576 61 81-01	1	Valve, Fuel Check
18	586 12 39-06	1	Assembly, Fuel Line w/ Valve
19	582 04 28-01	1	Solenoid
20	587 19 86-01	1	Harness, Battery Cable
21	587 04 45-50	1	Hose 3/16 x 50" Vapor
22	532 00 36-45	1	Grommet, Rubber
23	532 43 74-92	1	Grommet, Check Valve
24	532 13 92-77	1	Elbow
25	586 16 18-01	1	Meter, Service
26	532 14 04-01	1	Key, Ignition
27	586 10 82-01	1	Cable, Battery Positive
28	588 83 94-01	2	J Hook
29	545 22 71-01	2	Screw 6-19 x 7/16 Pan Head
30	539 11 12-29	1	Screw 1/4-20 x 5/8 Button Socket
31	532 14 18-41	2	Screw 10-16 x .65
32	874 82 27-01	2	Screw #10-24 x 3/4 Socket Head
33	539 99 06-45	2	Bolt 3/8-16 x 1 Round Head Square Neck
34	872 14 05-06	2	Bolt 5/16-18 x 3/4 Round Head Square Neck
35	817 49 04-08	2	Bolt 1/4-20 x 1/2
36	539 11 28-99	2	Nut 5/16-18 Hex Flange Nyloc
37	521 99 65-01	2	Nut 3/8-16 Hex Flange Nyloc
38	873 80 04-00	5	Nut 1/4-20 Hex Nyloc
	NOT SHOWN		
	586 33 73-01	1	Harness, Wiring
	532 10 97-48	1	Relay 40A
	586 54 81-01	1	Harness, LED Light

BRAKE / LIFT

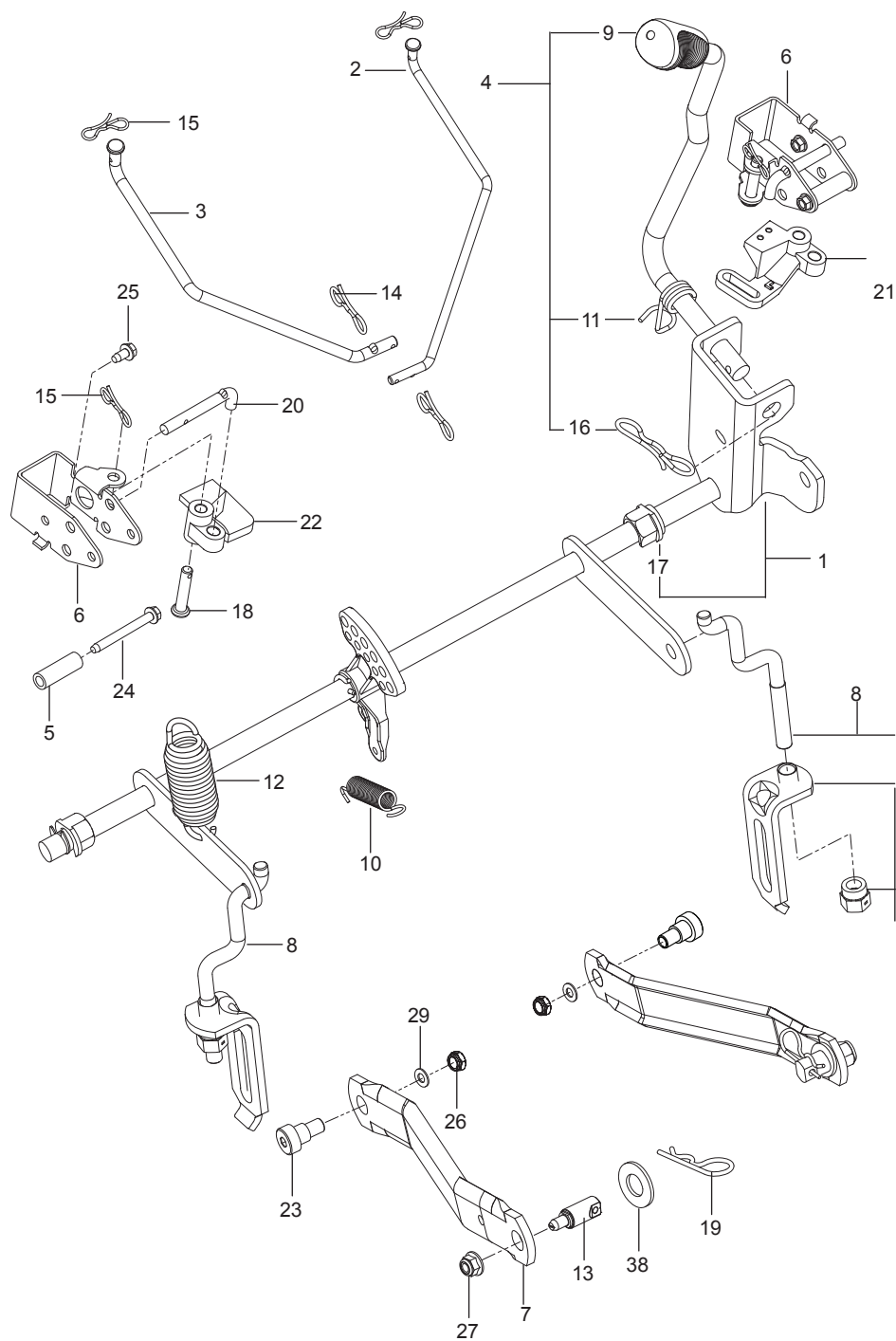

Ref.	Part No.	Qty	Description
1	587 62 31-01	1	Assembly, Shaft w/ Nuts, E-Rings
2	586 45 71-01	1	Link, Brake Left
3	586 45 72-01	1	Link, Brake Right
4	587 62 29-01	1	Assembly, Lift Handle
5	580 48 61-01	2	Spacer
6	585 68 21-01	2	Bracket, Bellcrank
7	532 19 51-85	2	Arm, Suspension
8	587 62 30-01	2	Assembly, Centering Lnk
9	532 44 50-60	1	Grip, Handle Black
10	586 86 76-01	1	Spring
11	532 19 63-14	1	Spring
12	539 11 87-62	1	Spring
13	532 19 51-61	2	Stud, w/ Anti-Rotate
14	532 19 42-08	2	Clip
15	587 22 53-01	6	Clip
16	532 19 42-09	1	Clip
17	510 18 49-01	2	Nut, Plastic
18	585 70 14-01	2	Pin 1/2 Clevis
19	539 97 69-89	2	Hair Pin
20	585 68 20-01	2	Pushrod
21	586 45 74-01	1	Bellcrank Left
22	586 45 75-01	1	Bellcrank Right
23	539 11 36-21	2	Bolt, Shoulder
24	586 56 13-01	2	Screw 1/4-20 x 2-1/4 Thread Roll
25	532 13 77-29	2	Screw 1/4-20 x 5/8 Thread Roll
26	539 20 02-82	2	Nut 3/8-16 Hex Jam Nyloc
27	539 11 28-99	2	Nut 5/16-18 Hex Flange Nyloc
28	819 21 21-13	2	Washer 1/2 Flat
29	819 13 13-16	8	Washer 3/8 SAE Flat

HYDRAULIC PUMP-MOTOR

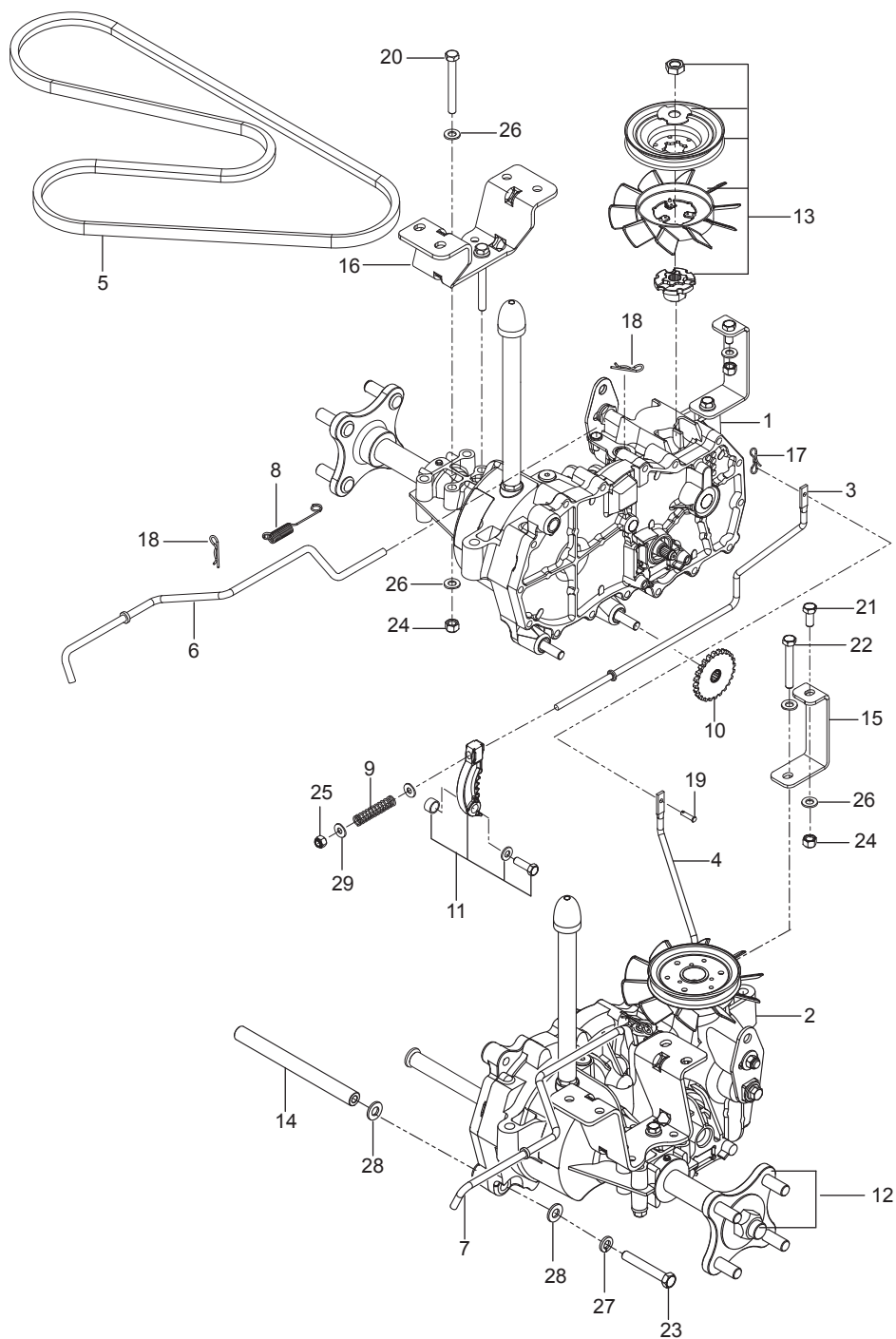

Ref.	Part No.	Qty	Description
1	510 37 56-01	1	EZT, Left
2	510 37 56-02	1	EZT, Right
3	574 03 05-01	1	Rod, EZT Brake Left
4	574 03 05-02	1	Rod, EZT Brake Right
5	539 11 04-11	1	Belt, EZT
6	585 47 44-01	1	Rod, Bypass Left
7	585 47 45-01	1	Rod, Bypass Right
8	586 66 51-01	2	Spring, Bypass
9	539 11 03-42	2	Spring, Brake Rod
10	539 12 00-80	2	Cog, Brake Disc
11	539 12 00-79	2	Assembly Kit, Brake Arm
12	575 50 70-01	1	Assembly Kit, Hub w/ Nuts
13	501 40 36-02	2	Assembly Kit, Blade, Pulley
14	510 18 41-04	2	Spacer Tube
15	580 80 65-02	2	Support, EZT Front
16	580 80 66-02	2	Mount, EZT Rear Blk
17	587 22 53-01	1	Clip
18	539 97 69-88	4	Clip
19	587 11 53-01	1	Pin, Clevis
20	874 78 05-44	4	Bolt 5/16-18 x 2-3/4
21	874 78 05-12	2	Bolt 5/16-18 x 3/4
22	874 78 05-36	2	Bolt 5/16-18 x 2-1/4
23	874 78 06-40	4	Bolt 3/8-16 x 2-1/2
24	873 80 05-00	8	Nut 5/16-18 Hex Nyloc
25	873 80 04-00	2	Nut 1/4-20 Hex Nyloc
26	819 11 11-16	16	Washer 5/16 SAE Flat
27	539 99 01-18	4	Washer 3/8 Splt Lock
28	819 13 13-16	8	Washer 3/8 SAE Flat
29	819 09 10-16	4	Washer 1/4 SAE Flat

WHEELS & TIRES

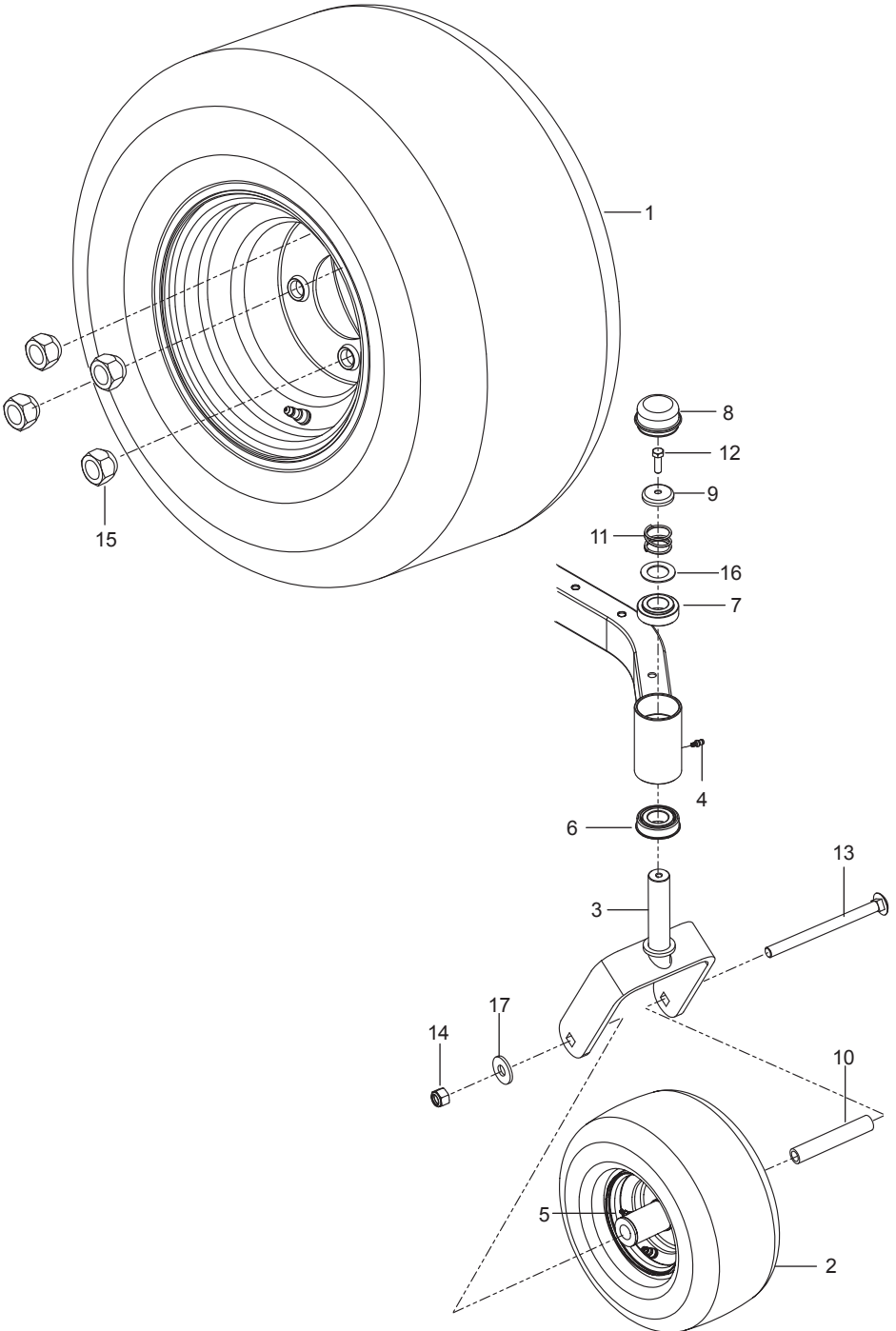

Ref.	Part No.	Qty	Description
1	579 75 34-01	2	Assembly, Wheel Rear 18 x 9.5-8
2	576 58 86-02	2	Wheel Assembly Caster 11 x 6.5
3	586 65 03-02	2	Yoke Orange
4	539 11 56-38	2	Zerk 3/16 Drive
5	539 10 33-00	2	Zerk
6	539 11 26-60	2	Bearing, Flanged
7	539 11 79-01	2	Bushing, Caster
8	539 10 25-35	2	Grease Cap
9	539 11 57-49	2	Plug, Caster
10	585 99 54-01	2	Spacer, Pivot
11	539 11 57-47	2	Spring, Caster
12	874 95 05-16	2	Bolt, Hex 5/16-18 x 1 Nylon Patch
13	576 60 15-01	2	Bolt 1/2-13 x 7-1/2 Round Head Square Neck
14	873 93 08-00	2	Nut 1/2-13 Hex Center Lock
15	539 10 11-73	8	Nut 1/2 Lug
16	539 11 56-75	2	Washer
17	819 18 22-12	2	Washer 9/16

MOWER DECK / CUTTING DECK

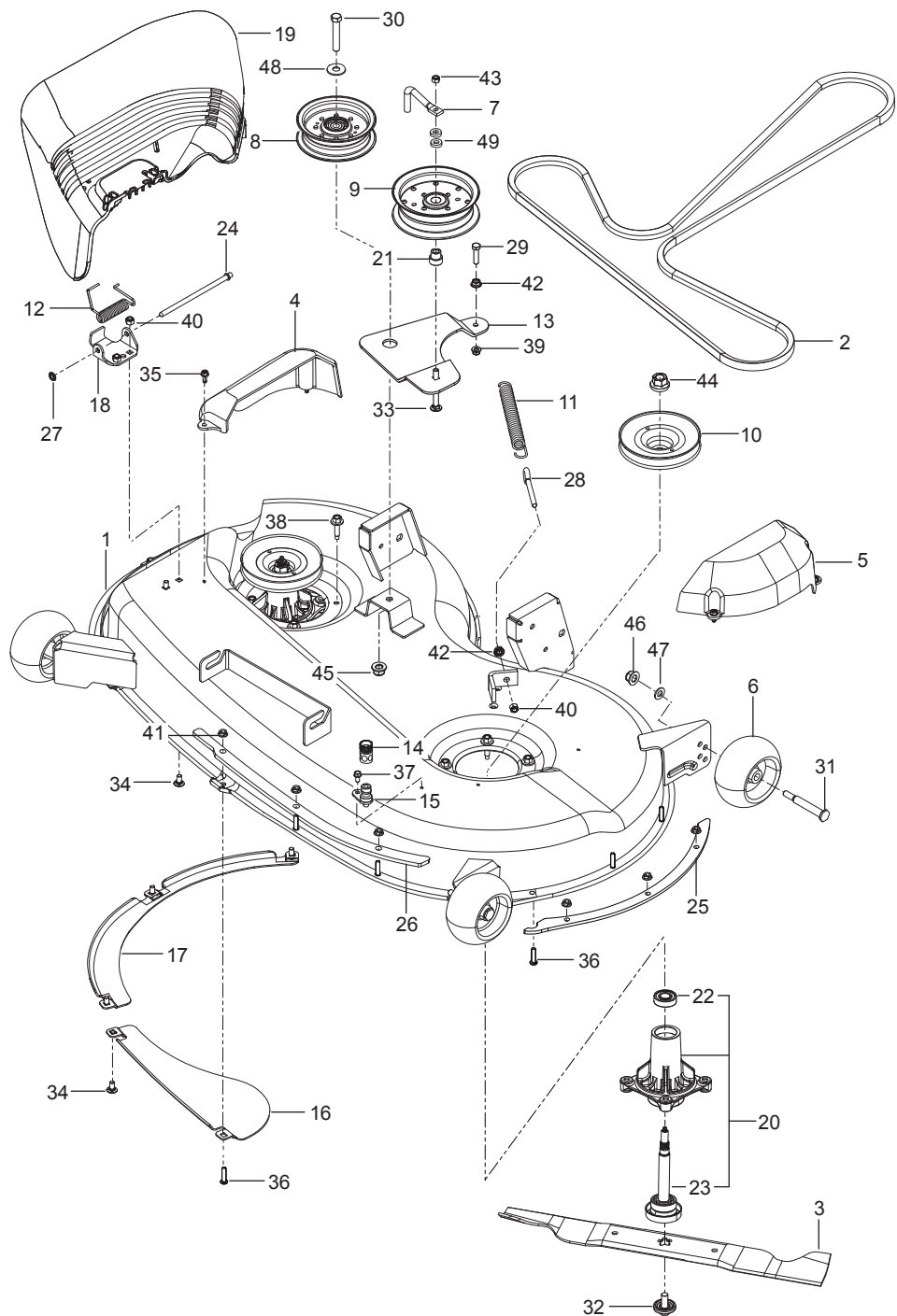

Ref.	Part No.	Qty	Description
1	581 07 10-01	1	Deck w/ Safety Decals
2	539 11 72-45	1	Belt, Deck
3	532 40 53-80	2	Blade, Hi-Lift
4	532 40 55-06	1	Shield, Belt Right
5	532 40 55-07	1	Shield, Belt Left
6	532 17 48-73	3	Wheel, Gauge
7	522 62 97-01	1	Keeper, Belt
8	532 19 61-04	1	Pulley, Idler
9	539 13 27-28	1	Pulley, Idler
10	539 11 39-62	2	Pulley, Deck
11	588 09 65-01	1	Spring, Deck Belt
12	532 17 81-02	1	Spring, Torsion
13	588 09 64-02	1	Arm, Idler
14	532 41 64-05	1	Coupling, Connect
15	532 41 55-98	1	Port, Washout
16	532 40 31-49	1	Baffle, Front
17	532 40 31-50	1	Baffle, Front Right
18	532 19 25-57	1	Bracket, Deflector
19	532 40 53-57	1	Shield, Deflector
20	587 12 52-01	2	Mandrel
21	539 11 20-76	1	Bushing, Idler
22	585 32 39-01	2	Bearing
23	587 25 56-01	2	Shaft
24	532 13 14-91	1	Rod, Hinge
25	585 31 78-05	1	Plate, Side
26	501 06 35-02	1	Plate Front
27	532 11 04-52	1	Pushnut
28	539 11 55-74	1	Eyebolt 5/16 x 3-1/2
29	874 78 05-20	1	Bolt 5/16-18 x 1-1/4 Hex Head
30	874 78 07-40	1	Bolt 7/16-14 x 2-1/2 Hex Head
31	532 19 34-06	3	Bolt 3/8-16 x 3-5/8 Shoulder
32	584 30 93-01	2	Bolt, Washer
33	872 11 06-18	1	Bolt 3/8-16 x 2-1/4 Round Head Square Neck
34	872 14 05-06	6	Bolt 5/16-18 x 3/4 Round Head Square Neck
35	532 13 77-29	4	Screw 1/4-20 x 5/8 Thread Roll
36	578 29 64-04	6	Screw 1/4-20 Button Head
37	539 99 10-34	1	Screw 10-24 x 5/8 Washer Head
38	584 95 39-01	8	Screw 5/16-18 Washer Head
39	539 11 28-99	1	Nut 5/16-18 Hex Flange Nyloc
40	873 80 05-00	8	Nut 5/16-18 Hex Nyloc
41	873 90 04-00	6	Nut 1/4-20 Hex Flange
42	539 99 05-85	2	Nut 5/16-18 Hex Whiz Lock
43	539 20 02-82	3	Nut 3/8-16 Hex Jam Nyloc
44	532 40 02-34	2	Nut 9/16 Top Center Lock
45	873 90 07-00	1	Nut 7/16-14 Hex Nyloc
46	873 90 06-00	3	Nut 3/8-16 Flange Lock
47	819 13 20-12	3	Washer 12 Gauge
48	539 10 48-64	1	Washer 7/16 Flat
49	539 10 95-62	2	Washer 3/8

SEAT

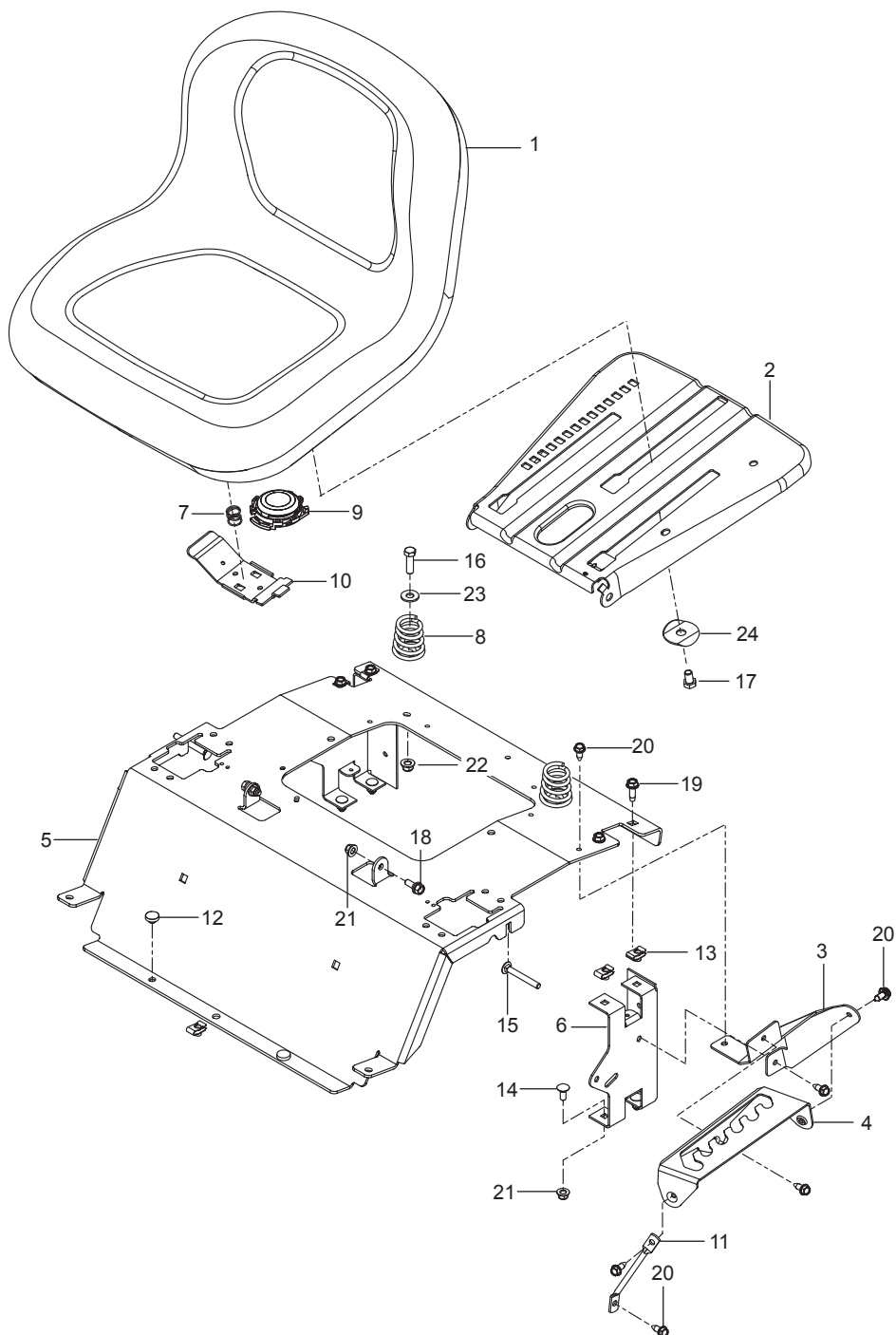

Ref.	Part No.	Qty	Description
1	532 43 98-22	1	Seat
2	587 23 20-02	1	Pan, Seat
3	586 22 08-02	1	Plate, Lift Support
4	586 22 12-02	1	Plate, Deck Lift
5	589 48 12-06	1	Support, Seat Orange
6	580 30 82-02	2	Support, Seat Rear Blk
7	532 19 82-00	1	Spring, Latch
8	589 48 35-01	2	Spring, Seat
9	581 42 93-02	1	Switch, Seat
10	532 19 76-61	1	Handle, Slide
11	586 42 86-01	1	Leg, Support
12	585 98 93-01	2	Grommet, Bumper
13	539 10 47-63	5	Retainer, U Type
14	872 14 05-06	4	Bolt 5/16-18 x 3/4 Round Head Square Neck
15	510 42 27-01	2	Bolt 5/16-18 x 2-1/2 Round Head Square Neck
16	874 78 06-20	2	Bolt 3/8-16 x 1-1/4
17	874 76 06-12	1	Bolt 3/8-16 x 3/4
18	539 11 03-03	2	Bolt 5/16-18 Shoulder
19	817 49 05-12	4	Screw 5/16-18 x 3/4 Thread Form
20	817 00 05-10	6	Screw 5/16-18 x 5/8 Washer Head
21	539 11 28-99	4	Nut 5/16-18 Hex Flange Nyloc
22	521 99 65-01	2	Nut 3/8-16 Hex Flange Nyloc
23	819 14 16-14	2	Washer 3/8 Std Flat
24	501 05 18-01	1	Washer, Winged
	NOT SHOWN - OPTIONAL		
	532 42 14-99	1	Kit, Arm Rest

DECALS

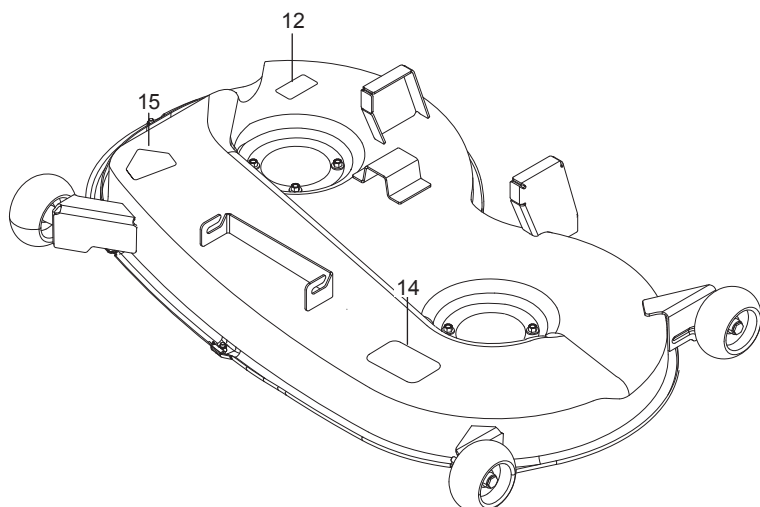
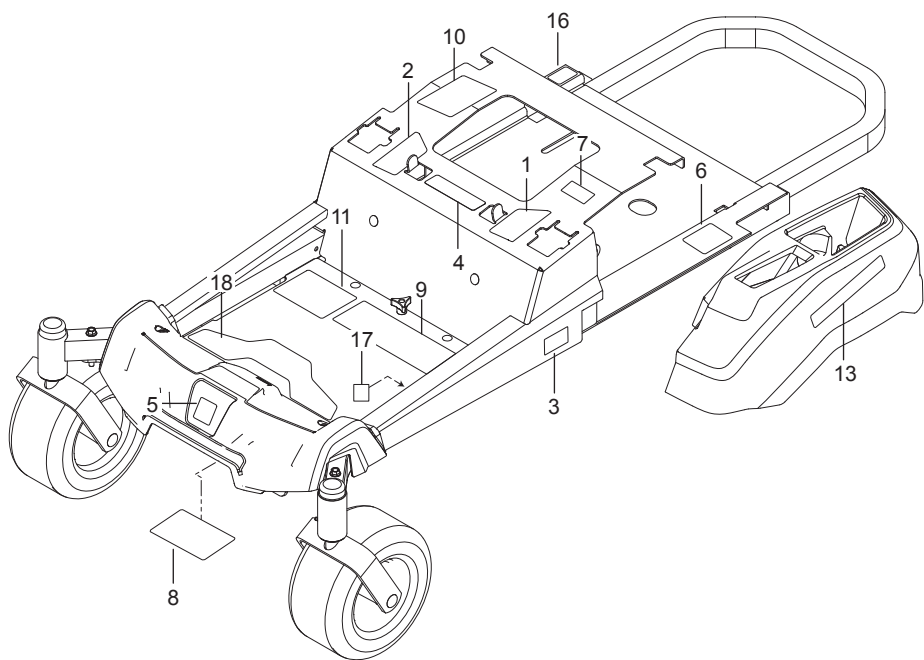

Ref.	Part No.	Qty	Description
1	587 59 56-01	1	Decal, Steer / Brake Left
2	587 59 55-01	1	Decal, Steer / Brake Right
3	587 21 93-01	2	Decal, Z 246
4	539 10 57-45	1	Decal, Battery Warning
5	532 42 86-77	1	Decal, Crown
6	539 10 83-85	1	Decal, Do Not Tow
7	539 10 83-86	1	Decal, Exit Mower
8	539 10 98-97	1	Decal, Service
9	583 93 40 01	1	Decal, Safety Warnings
10	532 42 38-29	1	Decal, Responsibility
11	588 03 51-01	1	Decal, Start
12	581 72 44-01	1	Decal, Deflector
13	577 46 90-01	2	Decal, Husqvarna
14	510 24 02-01	1	Decal, Belt Routing
15	584 90 46-01	1	Decal, Blade Warning
16	501 08 26-01	1	Decal, ECM Australia
17	581 72 41-02	1	Decal, 80 DBA
18	587 00 07-01	1	Pad, Abrasive

www.husqvarna.com

115 88 10-28 Rev A
2017-02-15