

Repair Parts Manual
Manual De Repuestos
YT42DXLS / 96043022000

Please read the operator's manual carefully and make sure you understand the instructions before using the machine.

Por favor lea cuidadosamente y comprenda estas instrucciones antes de usar esta maquina.



English/Spanish

115 81 01-96 Rev. 8



HOW TO USE THIS MANUAL

This manual is designed to provide the customer with a means to identify the parts on his/her tractor when ordering repair parts. The illustrations may or may not represent the actual assemblies; therefore, it is not recommended to use this manual as a guide to assemble or disassemble the tractor. Some hardware and parts are drawn larger in order to more readily identify them.

Each tractor has its own model number. The model number for your tractor can be found on the fender under the seat.

Support / Help

If you require assistance or have questions concerning the application, operation, maintenance or parts for your product:

- Visit our website: www.husqvarna.com
- Call Us Toll Free: 1-800-487-5951

When ordering parts, always give the following information:

- Product - "TRACTOR"
- MODEL NUMBER - "YT42DXLS" (96043022000)"
- Part Number
- Part Description

TABLE OF CONTENTS

SCHEMATIC	3
ELECTRICAL.....	4-5
CHASSIS	6-7
DRIVE.....	8-9
ENGINE.....	10-11
STEERING	12-13
MOWER DECK.....	14-15
MOWER LIFT.....	16
SEAT	17
DECALS.....	18

COMO UTILIZAR ESTE MANUAL

Este manual está diseñado para brindarle al comprador un medio para identificar las piezas del tractor para cuando necesite hacer el pedido de un repuesto. Las ilustraciones pueden o no representar los ensambles reales; por lo tanto, no se recomienda utilizar este manual como una guía para ensamblar o desarmar el tractor. Algunos accesorios y piezas están dibujados en tamaños más grandes para identificarlos con mayor facilidad.

Cada tractor tiene su propio número de modelo. El número de modelo del tractor se encuentra en el guardabarros debajo del asiento.

Soporte / Ayuda

Si necesita asistencia o tiene alguna pregunta acerca de la aplicación, operación, mantenimiento o piezas de su producto:

- Visite nuestro sitio web: www.husqvarna.com
- Llámenos de manera gratuita al: 1-800-487-5951

Cuando haga el pedido de una pieza, siempre brinde la siguiente información:

- Producto: "TRACTOR"
- NÚMERO DE MODELO: "YT42DXLS" (96043022000)"
- Número de pieza
- Descripción de la pieza

ÍNDICE

DIAGRAMA.....	19
DIAGRAMA ELÉCTRICO.....	20-21
CHASIS	22-23
TRANSMISIÓN	24-25
MOTOR	26-27
DIRECCIÓN	28-29
PLATAFORMA DE LA CORTADORA DE CÉSPED.....	30-31
ELEVACIÓN DE LA CORTADORA DE CÉSPED.....	32
ASIENTO.....	33
CALCOMANÍAS.....	34

TRACTOR - MODEL NO. YT42DXLS (96043022000), PROD. NO. 960 43 02-20

SCHEMATIC

SCH12

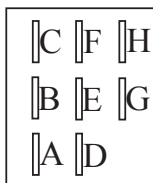
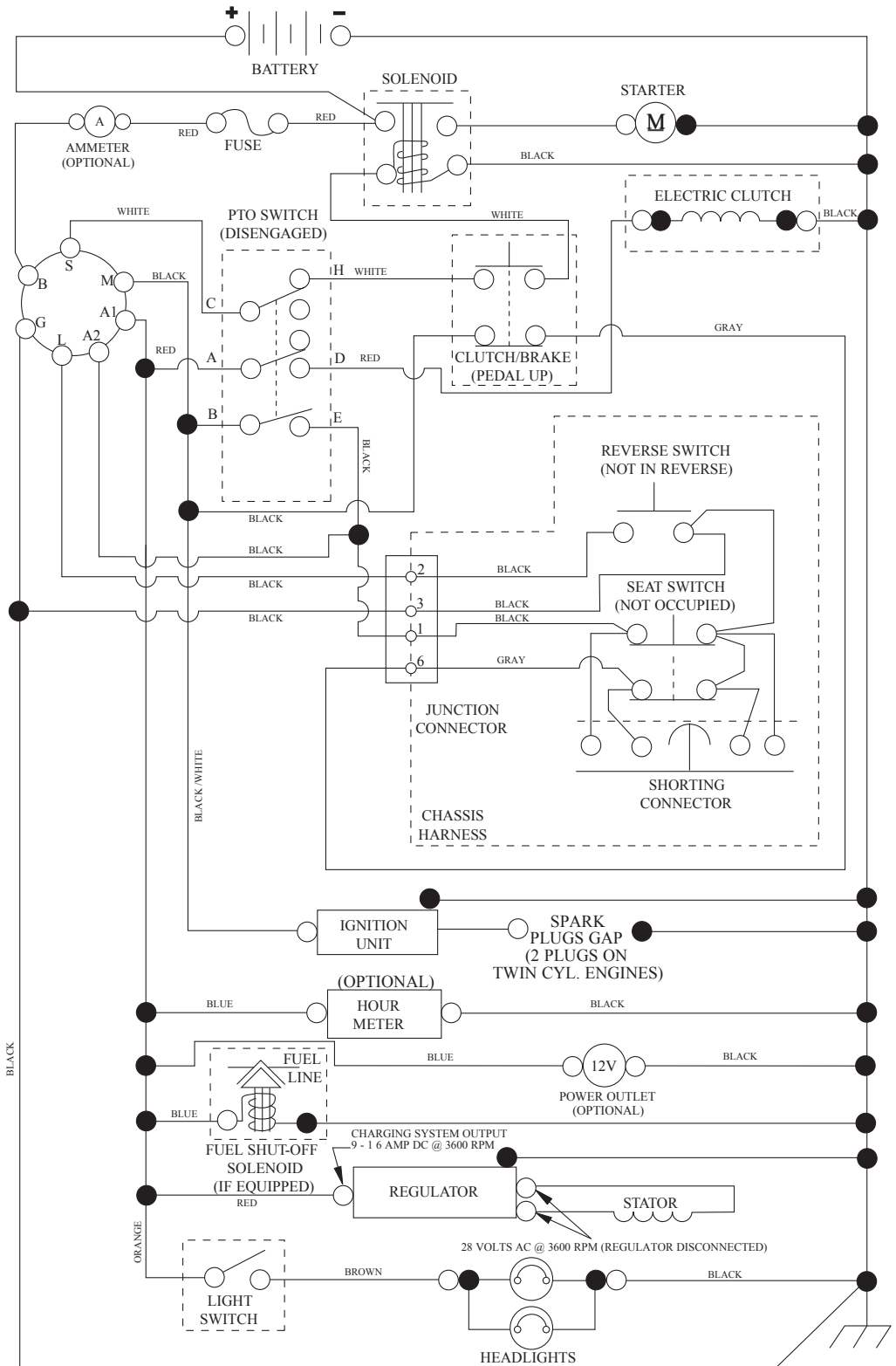

PTO SWITCH
(MATING SIDE)

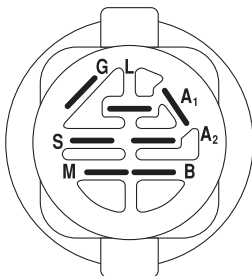

IGNITION SWITCH

POSITION	CIRCUIT	"MAKE"
OFF	M+G+A1	
RUN/OVERRIDE	B+A1	
RUN	B+A1	L+A2
START	B + S + A1	

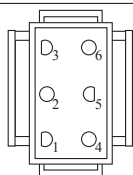

CHASSIS HARNESS
CONNECTOR
(MATING SIDE)

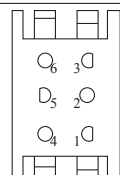

DASH HARNESS
CONNECTOR

WIRING INSULATED CLIPS
NOTE: IF WIRING INSULATED
CLIPS WERE REMOVED FOR
SERVICING OF UNIT, THEY
SHOULD BE RE-INSTALLED TO
PROPERLY SECURE YOUR
WIRING.

●
NON-REMOVABLE
CONNECTIONS

○
REMOVABLE
CONNECTIONS

**TRACTOR - MODEL NO. YT42DXLS (96043022000), PROD. NO. 960 43 02-20
ELECTRICAL**

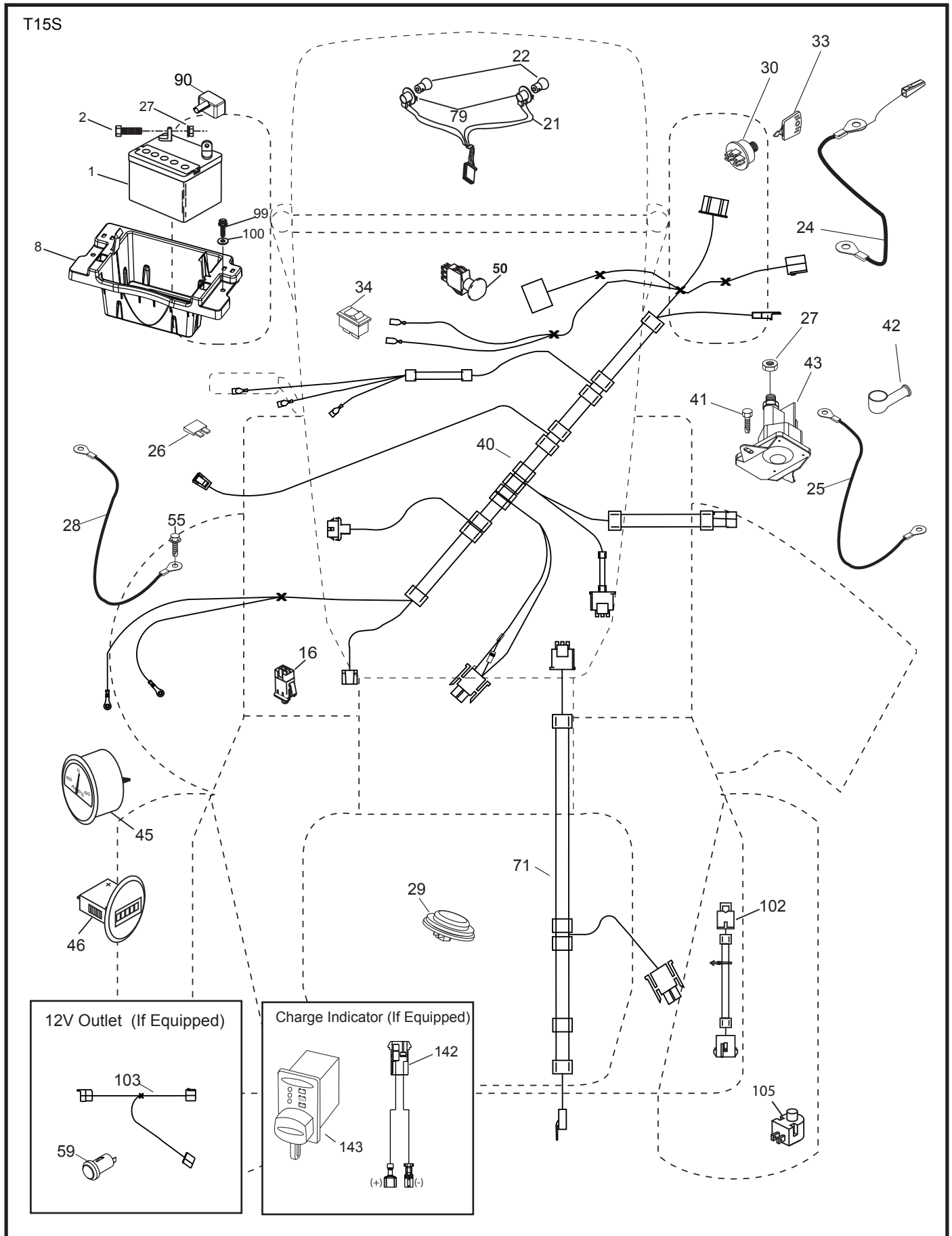

**TRACTOR - MODEL NO. YT42DXLS (96043022000), PROD. NO. 960 43 02-20
ELECTRICAL**

KEY NO.	PART NO.	DESCRIPTION
1	532 16 34-65	Battery
2	874 76 04-12	Bolt Hex Head 1/4-20 x 3/4
8	587 20 51-01	Box Battery
16	532 17 61-38	Switch Interlock Push-In
21	532 40 02-52	Harness Socket Light w/4152J
22	532 00 41-52	Bulb Light
24	585 55 56-01	Cable Battery
25	585 55 55-01	Cable Starter
26	532 17 51-58	Fuse
27	873 51 04-00	Nut Keps Hex 1/4-20 unc
28	532 41 65-88	Cable, Ground
29	532 40 15-45	Switch, Seat
30	532 19 33-50	Switch, Ign
33	532 41 19-33	Key\Chain
34	532 11 07-12	Switch Light / Reset
40	501 13 31-01	Harness Ign. Dash
41	817 72 04-08	Screw Thd Cut 1/4-20 x 1/2
42	532 13 15-63	Cover, Terminal
43	532 19 25-07	Solenoid
45	587 55 39-03	Ammeter Gauge Round
46	587 55 40-03	Gauge Servicere minder Hrmtr
50	532 17 46-51	Switch PTO
55	817 06 05-12	Screw Thdrol 5/16-18 x 3/4 TYTT
59	532 40 03-03	Outlet 12-Volt
71	532 19 42-76	Harness Ign. Chassis
79	532 17 52-42	Socket Asm Bulb Twistlock
90	532 43 53-95	Cover Terminal
99	817 67 04-12	Screw Hexwsh Thdrol 1/4-20 x 3/4
100	819 09 14-16	Washer 9/32 x 7/8 x 16 Ga.
102	532 40 44-54	Harness Pigtail
103	532 42 17-47	Harness 12-Volt Pigtail
105	532 40 75-68	Switch Reverse TT Pedal Control
142	583 85 78-01	Charge Port Pigtail
143	532 44 80-59	Charge Port

NOTE: All component dimensions given in U.S. inches
1 inch = 25.4 mm.

**TRACTOR - MODEL NO. YT42DXLS (96043022000), PROD. NO. 960 43 02-20
CHASSIS**

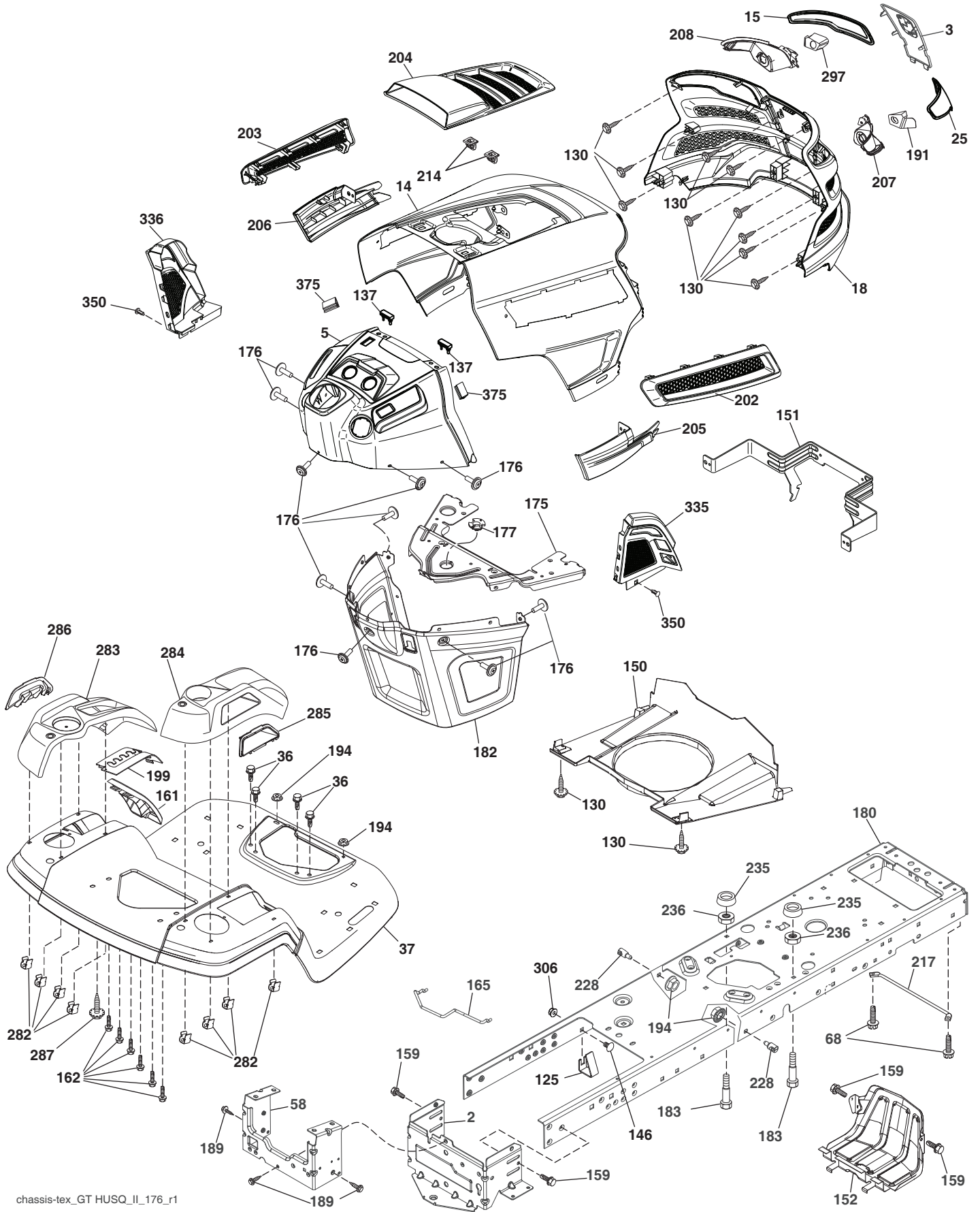

**TRACTOR - MODEL NO. YT42DXLS (96043022000), PROD. NO. 960 43 02-20
CHASSIS**

KEY NO.	PART NO.	DESCRIPTION	KEY NO.	PART NO.	DESCRIPTION
2	532 41 22-82	Drawbar	199	532 41 34-85	Plate Deck Lift
3	532 44 44-81	Applique Sub Asm.	202	532 43 97-28	Vent Side Hood RH
5	501 74 71-01	Dash	203	532 43 97-27	Vent Side Hood LH
14	532 44 11-77	Hood	204	532 43 57-14	Vent Top Hood
15	532 43 97-33	Lens LH	205	532 43 97-30	Side Trim RH
18	532 44 06-53	Grille	206	532 43 97-29	Side Trim LH
25	532 44 33-85	Lens RH	207	532 43 97-34	Bezel RH
36	817 06 05-12	Screw 5/16-18 x 3/4	208	532 43 97-35	Bezel LH
37	532 44 11-78	Fender	214	532 19 91-45	Clip Retainer Tinner
58	532 41 22-80	Drawbar Upper	217	532 40 91-67	Rod Pivot
68	817 49 05-08	Screw Thdrol 5/16-18 x 1/2	228	532 19 51-61	Stud Fastener
125	581 68 48-01	Clip Fuel Line	235	532 40 61-29	Spacer Fender
130	532 41 63-58	Screw 10 x 0.750 BOS Thread	236	873 93 05-00	Nut Lock 5/16-18 unc
137	532 40 75-90	Bumper Dash	282	532 41 41-10	Clip Retainer Console
146	581 85 79-01	Bolt	283	532 43 98-61	Console Deck Lift
150	532 43 97-74	Air Duct	284	532 43 98-23	Console Shift
151	532 43 66-70	Bracket Pivot Hood	285	532 41 63-15	Console Insert RH
152	532 43 98-70	Shield Browning	286	532 41 63-17	Console Insert LH
159	817 00 06-12	Screw 3/8-16 x 3/4	287	817 60 04-06	Screw 1/4-20 X 3/8
161	532 43 97-81	Window Fuel	297	532 43 74-56	Insert Reflective LH
162	532 14 24-32	Screw Hex Wsh Hi-Lo 1/4 x 1/2 unc	306	873 90 06-00	Nut Lock
165	532 19 43-30	Support Tank Rear	335	532 44 82-04	Cover-RH Lower
175	532 19 63-04	Crossmember	336	532 44 53-09	Cover-LH Lower
176	532 40 07-76	Screw 10-24 x 5/8	350	532 44 51-43	Clip X-mas Tree
177	532 19 52-28	Bushing Steering	375	586 90 82-01	Dash Clip-On Bumper
180	532 44 55-59	Chassis	--	532 43 18-82	Kit Guard Brush
182	532 40 68-59	Dash Lower			
183	874 52 05-20	Bolt 5/16-18 x 1-1/4			
189	817 00 05-12	Screw 5/16-18 x 3/4			
191	532 43 74-55	Insert Reflective RH			
194	873 90 05-00	Nut Lock Hex Flange 5/16-18			

NOTE: All component dimensions given in U.S. inches
1 inch = 25.4 mm.

TRACTOR - MODEL NO. YT42DXLS (96043022000), PROD. NO. 960 43 02-20 DRIVE

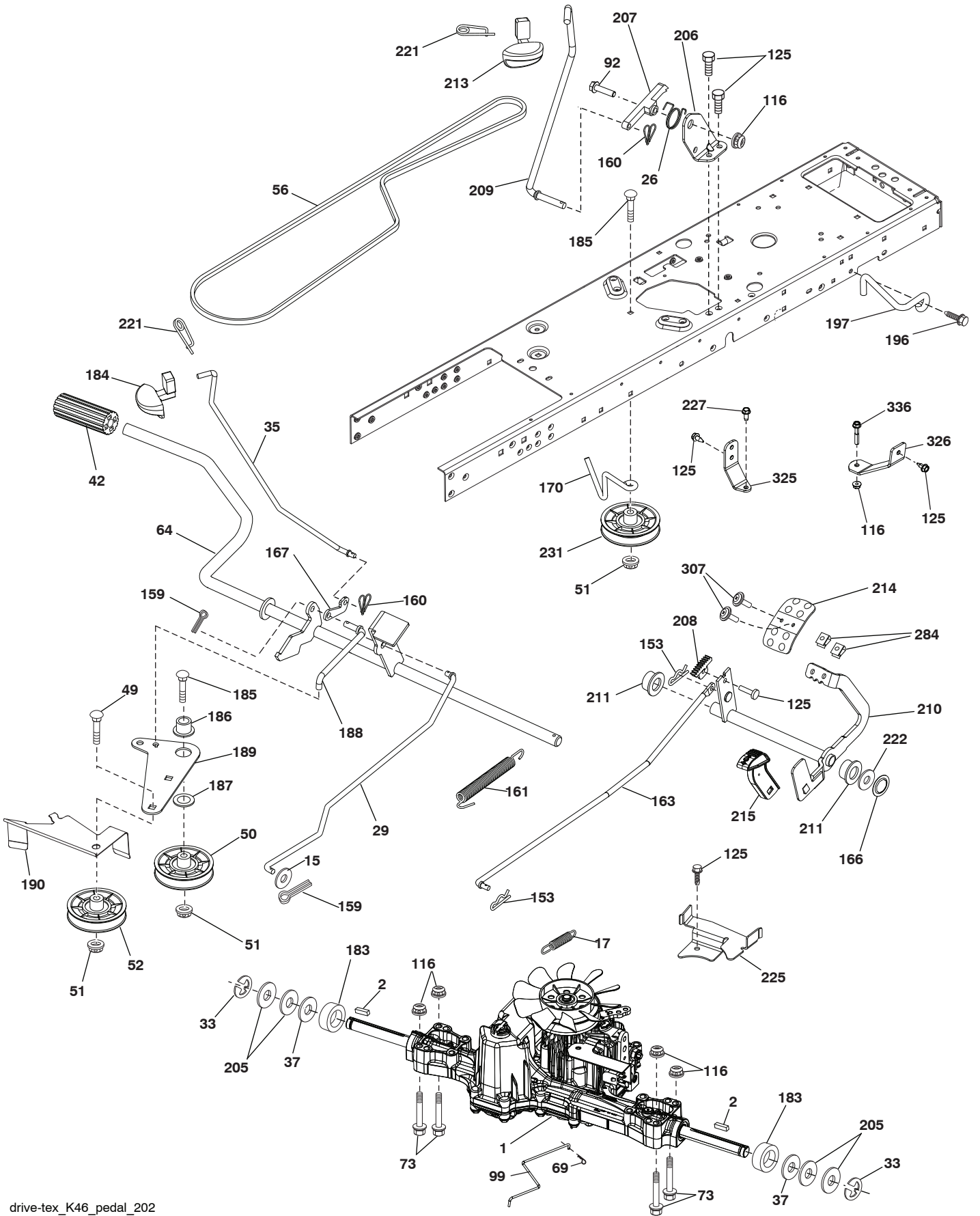

drive-tex_K46_pedal_202

TRACTOR - MODEL NO. YT42DXLS (96043022000), PROD. NO. 960 43 02-20 DRIVE

KEY NO.	PART NO.	DESCRIPTION	KEY NO.	PART NO.	DESCRIPTION
1	---	Transaxle, TUFFTORQ K46 CR (501051401) (Order parts from transaxle manufacturer.)	184	587 65 37-01	Handle Parking Brake
2	532 12 35-83	Key	185	872 11 06-22	Bolt Rdhd Sqnk 3/8-16 x 2-1/2
15	819 13 13-16	Washer 13/32 x 13/16 x 16 Ga.	186	532 19 43-21	Spacer Retainer
17	532 41 36-78	Spring, Brake	187	819 13 32-10	Washer
26	532 19 96-79	Spring Return Cruise	188	582 21 70-01	Link Clutch Ground Drive Long
29	532 40 38-06	Rod, Brake	189	532 19 43-17	Bellcrank Ground Drive
33	812 00 00-01	Ring E	190	532 19 43-18	Keeper Bellcrank Ground Drive
35	583 86 45-01	Rod, Brake, Park	196	817 00 06-16	Screw 3/8-16 x 1
37	532 18 89-67	Washer Hardened	197	587 40 20-01	Bracket Clutch Anti-Rotation
42	532 12 48-72	Cover, Foot Pedal	205	532 12 17-48	Washer
49	872 11 06-14	Bolt	206	532 44 85-96	Bracket Mount Latch Cruise
50	532 19 43-27	Pulley Idler Flat	207	587 03 14-01	Latch Control Cruise
51	873 90 06-00	Lock Nut 3/8-16	208	532 19 78-69	Gear Sector Control Cruise
52	532 19 43-26	Idler V-Groove	209	532 19 95-92	Rod Control Cruise
56	532 13 09-69	V-Belt, Drive	210	532 40 09-80	Rocker Asm. Pedal Control
64	532 19 78-65	Shaft Asm. Pedal Brake Control	211	532 12 01-83	Bearing Nylon
69	532 42 33-03	Hairpin Soft Zink .059 x 1.125	213	532 40 31-19	Knob Control Cruise
73	874 49 05-40	Bolt Hex 5/16-18 x 2-1/2 Gr. 5	214	532 41 68-63	Pedal Forward
92	874 76 05-20	Bolt Fin Hex 5/16-18 unc x 1.25	215	586 60 65-02	Pedal Reverse
99	582 40 45-01	Rod Spring Bypass	221	532 40 31-87	Retainer Spring Clip Handle
116	873 90 05-00	Nut Lock Hex Flange 5/16-18	222	879 21 20-10	Washer 21/32 x 1-1/4 x 10 Ga.
125	817 00 05-12	Screw 5/16-18 x 3/4	225	532 40 33-19	Keeper Belt Trans.
153	532 12 47-88	Retainer Spring	227	817 49 05-12	Screw 5/16-18 x 3/4
159	876 02 04-12	Pin Cotter 1/8 x 3/4	231	532 40 72-87	Idler V-Groove
160	532 16 94-84	Retainer Clip	284	532 41 76-93	Nut U-CHNL 1/4-20 550DP .350 PNL
161	532 10 57-09	Spring, Return, Clutch	307	874 18 04-12	Screw 1/4-20 x 3/4
163	532 44 82-75	Rod Pedal Control	325	586 43 12-02	Bracket
166	532 42 91-64	Nut Push	326	586 00 11-02	Bracket
167	532 40 52-57	Latch Brake Parking	336	587 25 96-01	Bolt
170	532 41 34-30	Keeper Belt Centerspan			
183	532 13 70-57	Spacer Split			

NOTE: All component dimensions given in U.S. inches
1 inch = 25.4 mm.

**TRACTOR - MODEL NO. YT42DXLS (96043022000), PROD. NO. 960 43 02-20
ENGINE**

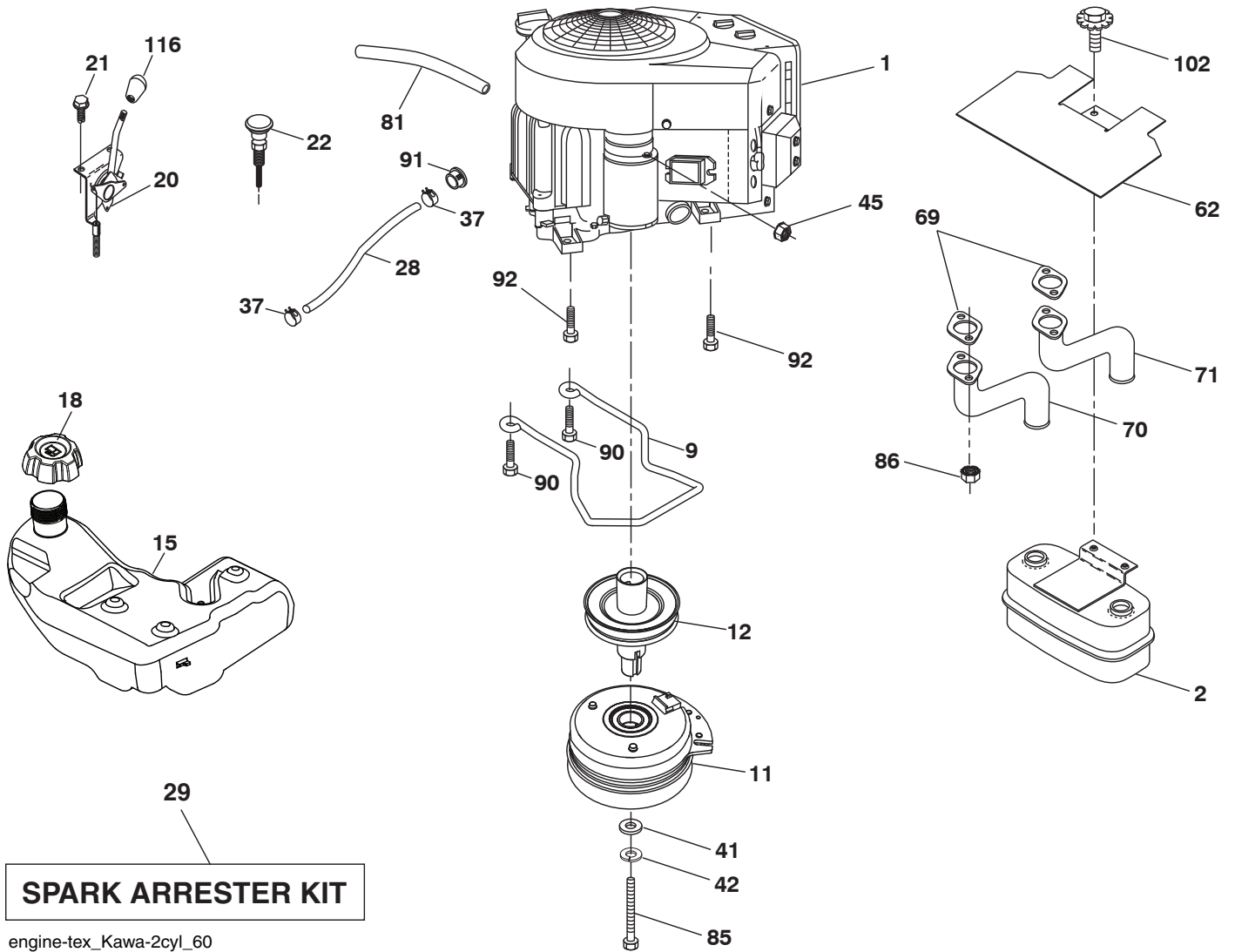

**TRACTOR - MODEL NO. YT42DXLS (96043022000), PROD. NO. 960 43 02-20
ENGINE**

KEY NO.	PART NO.	DESCRIPTION
1	-----	Engine Kawa Model No. FR651V-AS28 (581411101) (Order parts from engine manufacturer.)
2	589 81 87-01	Muffler
9	501 83 26-01	Keeper Belt Engine
11	587 25 50-01	Clutch Electric
12	586 89 96-01	Pulley Engine
15	532 43 80-25	Tank Fuel
18	585 12 48-01	Cap Fuel
20	532 42 43-41	Control Throttle
21	532 41 63-58	Screw #10 x 0.750 BOS Thread
22	532 18 95-41	Control Choke
28	532 40 11-35	Fuel Line
29	532 13 71-80	Spark Arrester Kit
37	532 12 34-87	Clamp Hose
41	532 12 61-97	Washer 1-1/2 x 15/32 x .250
42	810 04 07-00	Washer Lock 7/16
45	873 51 04-00	Nut Keps Hex 1/4-20 unc
62	532 43 40-17	Shield Heat Muffler
69	532 17 81-51	Gasket
70	583 95 56-01	Pipe Exhaust LH
71	583 95 57-01	Pipe Exhaust RH
81	532 14 84-56	Tube Drain Oil
85	871 17 07-80	Bolt 7/16-20 x 5
86	532 18 43-62	Nut Hx Flg Toplock MB-1.25
90	817 00 06-16	Screw 3/8-16 x 1
91	532 18 74-95	Bushing 1.375 OD
92	817 12 06-16	Screw 3/8-16 x 1
102	817 00 05-12	Screw 5/16-18 x 3/4
116	539 13 26-24	Knob

NOTE: All component dimensions given in U.S. inches
1 inch = 25.4 mm

For engine service and replacement parts, call the toll free
number for your engine manufacturer listed below:

Kawasaki 1-949-460-5688

TRACTOR - MODEL NO. YT42DXLS (96043022000), PROD. NO. 960 43 02-20
STEERING ASSEMBLY

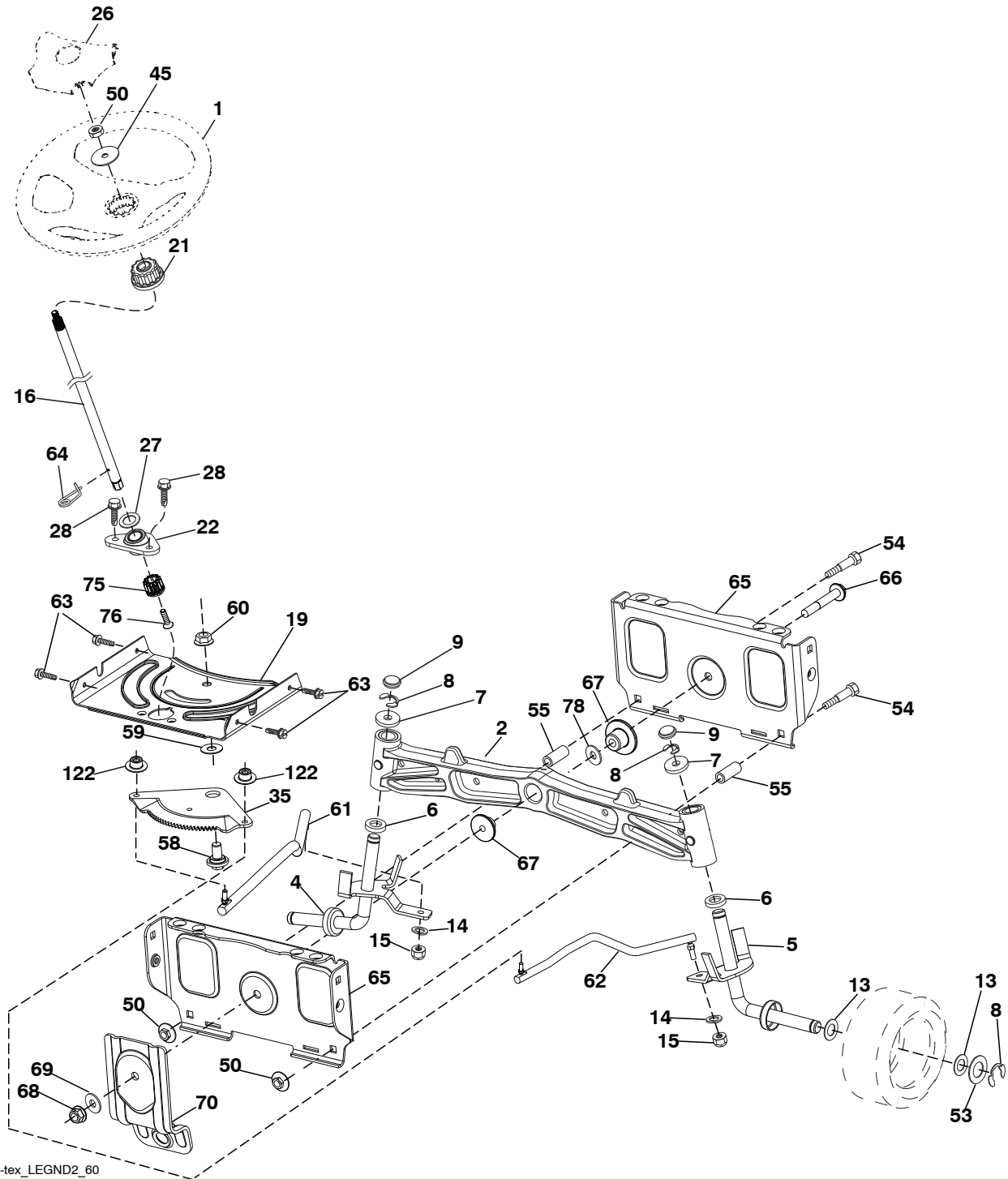

Steering-tex_LEGND2_60

**TRACTOR - MODEL NO. YT42DXLS (96043022000), PROD. NO. 960 43 02-20
STEERING ASSEMBLY**

KEY NO.	PART NO.	DESCRIPTION
1	532 43 97-40	Wheel, Steering
2	532 19 59-68	Axle Asm., Front
4	586 72 40-01	Spindle Asm., LH
5	586 72 41-01	Spindle Asm., RH
6	532 12 49-31	Bearing, Race Thrust Harden
7	532 12 17-48	Washer 25/32 x 1-5/8 x 16 Ga.
8	812 00 00-29	Ring, Clip #T5304-75
9	532 12 12-32	Cap, Spindle
13	532 12 17-49	Washer 25/32 x 1-1/4 x 16 Ga.
14	810 04 06-00	Washer, Lock Hvy Hlcl Spr 3/8
15	873 54 06-00	Nut, Crown Lock 3/8-24 unf
16	587 01 60-02	Steering Shaft
19	532 19 47-29	Plate Steering
21	586 84 02-01	Adapter Wheel Steering
22	585 02 98-02	Bearing
26	532 43 97-43	Insert, Wheel Steering
27	819 21 16-16	Washer
28	817 00 06-12	Screw 3/8-16 x 3/4
35	532 19 47-32	Gear, Sector Plate
45	587 01 64-01	Washer 3/8 ID 2-3/8 OD 12 Ga. PLTD
50	873 90 06-00	Nut Lock Flg 3/8-16 unc
53	532 18 89-67	Washer Hardened .793 x 1.637 x .060
54	874 76 06-36	Bolt Hex 3/8-16 unc x 2-1/4
55	532 41 47-36	Spacer Brace Axle
58	532 19 47-47	Bolt Shoulder Sector Pivot CFM
59	532 19 47-48	Washer Thrust Sector Steering
60	873 97 10-00	Nut Flange Lock 5/8-11
61	532 19 47-40	Draglink, LH
62	532 19 47-41	Draglink, RH
63	817 00 05-12	Screw 5/16-18 x 3/4
64	532 19 98-49	Retainer Clip Spring Steering
65	532 19 47-34	Brace Axle Front
66	871 02 07-48	Bolt Hex Fghd 7/16-14 x 3 Serr
67	532 19 47-37	Bushing PM Front Axle
68	873 90 07-00	Nut Lock Flange 7/16-14 Gr. 5
69	532 19 91-62	Washer 1.5 x .505 x .118
70	585 33 88-01	Bracket Deck Susp. Front
75	580 68 37-01	Pinion
76	580 68 36-01	Screw Head Sock
78	532 05 70-79	Washer Thrust
122	532 44 49-62	Cap Gear

NOTE: All component dimensions given in U.S. inches
1 inch = 25.4 mm.

TRACTOR - MODEL NO. YT42DXLS (96043022000), PROD. NO. 960 43 02-20
MOWER DECK

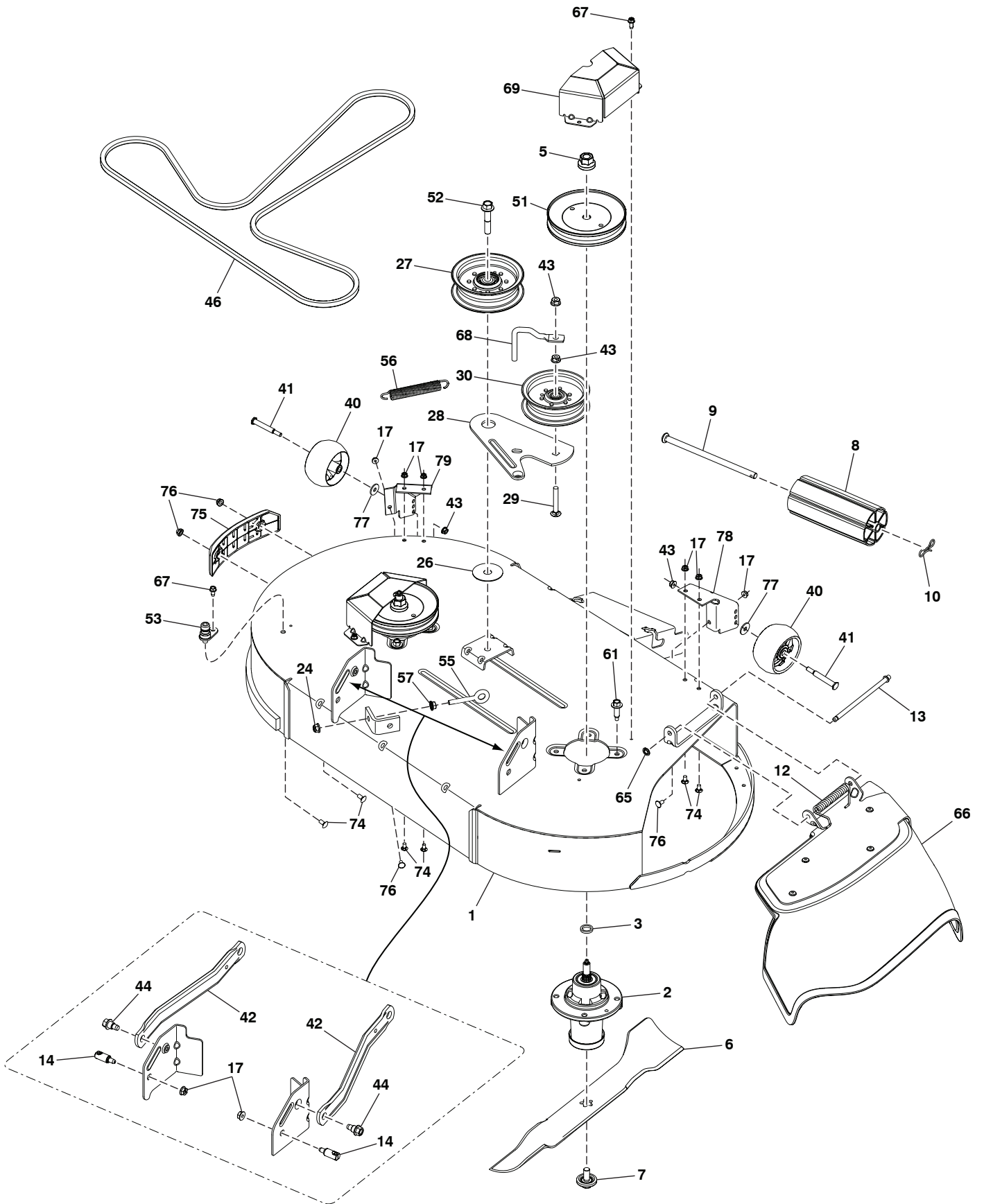

**TRACTOR - MODEL NO. YT42DXLS (96043022000), PROD. NO. 960 43 02-20
MOWER DECK**

KEY NO.	PART NO.	DESCRIPTION
1	589 02 90-02	Deck Weldment
2	539 11 21-70	Housing Assembly
3	539 18 76-90	Washer-Spacer
5	539 10 75-90	Nut 9/16 Top Center Lock
6	586 91 81-01	Blade
7	532 19 30-03	Bolt, 7/16, Assy Blade
8	532 17 60-66	Roller, Nose
9	532 17 91-27	Rod, Roller, Nose
10	532 19 42-08	Clip Retainer
12	587 35 47-01	Spring
13	532 13 14-91	Rod Hinge 42/46/48/54
14	532 19 51-61	Stud, Fasten w/ Anti-Rotate
17	873 90 05-00	Nut Lock Hex Flanged 5/16-18
24	539 11 28-99	Nut 5/16-18 Hex Flange Nyloc
26	532 17 85-15	Washer, Flat Hardened
27	532 19 61-04	Pulley, Idler Spec. Hub
28	586 87 40-02	Arm 42FCS Clutching
29	872 14 06-20	Bolt RDHD
30	532 19 61-06	Pulley, Idler
40	532 17 48-73	Gauge Wheel
41	532 19 34-06	Bolt Shoulder
42	532 19 51-85	Arm, Susp., Rear
43	873 90 06-00	Nut Lock Flg 3/8-15 unc
44	532 19 65-39	Bolt Shoulder
46	587 27 01-01	Belt 42 FCS
51	532 19 97-91	Pulley, Mandrel
52	588 43 83-01	Screw 7/16-14 x 2.125 Hex Wsh Hd.
53	532 41 55-98	Washout Port
55	539 11 55-74	Eyebolt 5/16 x 3-1/2
56	587 35 84-01	Spring
57	539 99 05-85	Nut 5/16-18 Hex
61	584 95 39-01	Bolt Hx
65	532 11 04-52	Nut Push
66	587 30 57-01	Deflector Assy 42 FCS
67	532 13 77-29	Screw
68	532 19 84-68	Keeper Belt Idler
69	586 93 68-05	Cover 42" Mandrel
74	872 11 05-05	Bolt 5/16-18 x 5/8
75	579 81 10-01	Bumper
76	585 93 81-01	Nut Acorn
77	819 13 20-12	Washer 12 Ga.
78	501 80 83-02	Gauge Wheel Bracket RH
79	590 43 90-02	Gauge Wheel Bracket LH
--	532 41 64-05	Connect Quick Coupling
--	582 16 51-01	Mower Deck Complete

NOTE: All component dimensions given in U.S. inches
1 inch = 25.4 mm

TRACTOR - MODEL NO. YT42DXLS (96043022000), PROD. NO. 960 43 02-20
MOWER LIFT

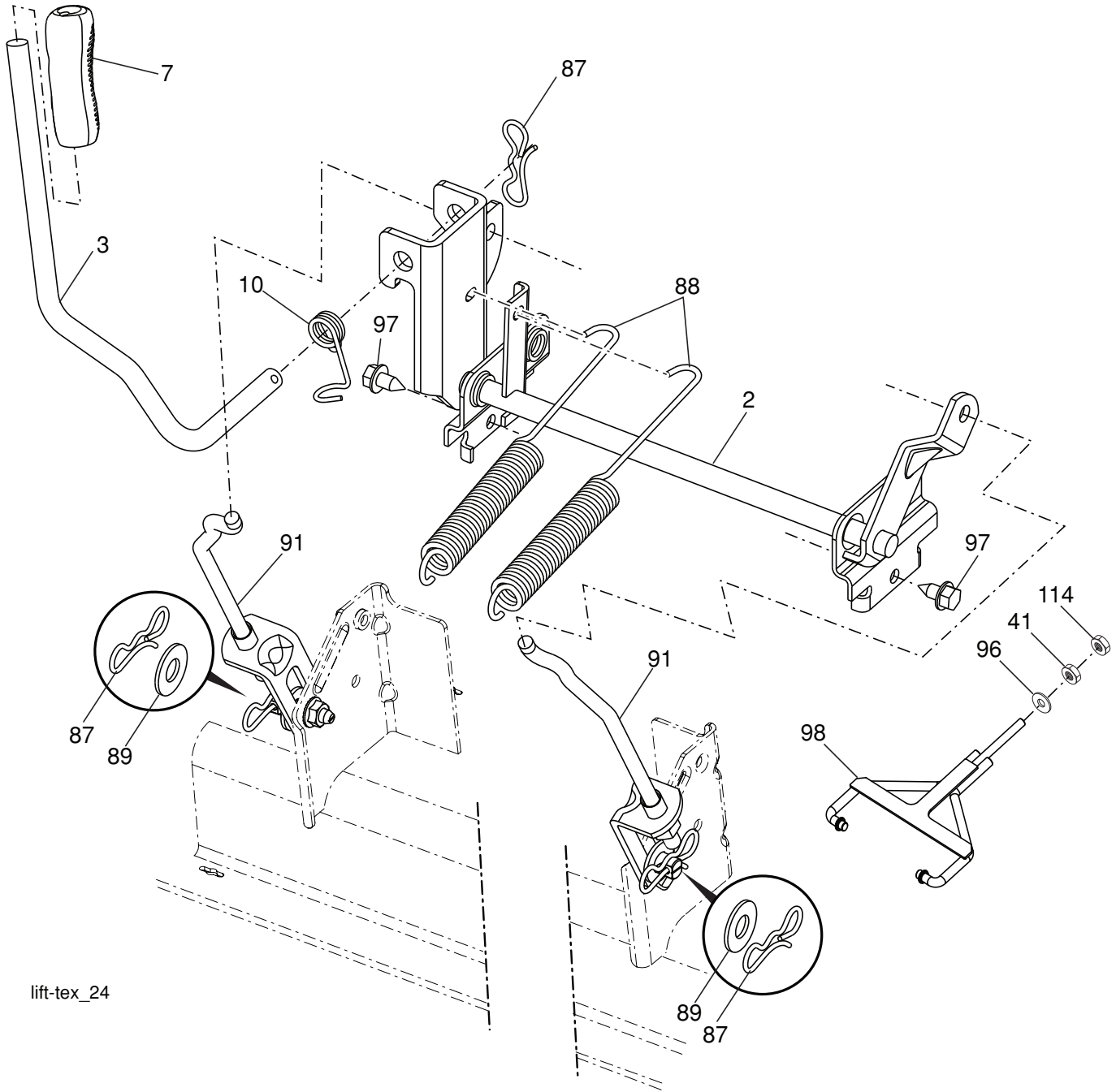

lift-tex_24

KEY PART NO.	PART NO.	DESCRIPTION
2	532 42 20-27	Shaft Asm., Lift
3	532 19 52-31	Lever Asm., Lift RH
7	580 96 23-01	Grip, Lever
10	532 19 63-14	Spring Torsion
41	532 17 59-94	Nut, Lift Link
87	532 19 42-09	Pin Cotter 7/16 Bow Tie Lock
88	532 41 07-10	Spring Lift Assist
89	819 19 19-12	Washer Clear Zinc

KEY PART NO.	PART NO.	DESCRIPTION
91	532 40 34-07	Link Lift Susp Mower Rear
96	532 19 52-63	Bushing, Spherical
97	817 00 06-12	Screw 3/8-16 x .75
98	574 82 25-01	Link Lift Susp. Front Mower
114	873 36 07-00	Nut Jam 7/16-20

NOTE: All component dimensions given in U.S. inches
 1 inch = 25.4 mm.

TRACTOR - MODEL NO. YT42DXLS (96043022000), PROD. NO. 960 43 02-20 SEAT ASSEMBLY

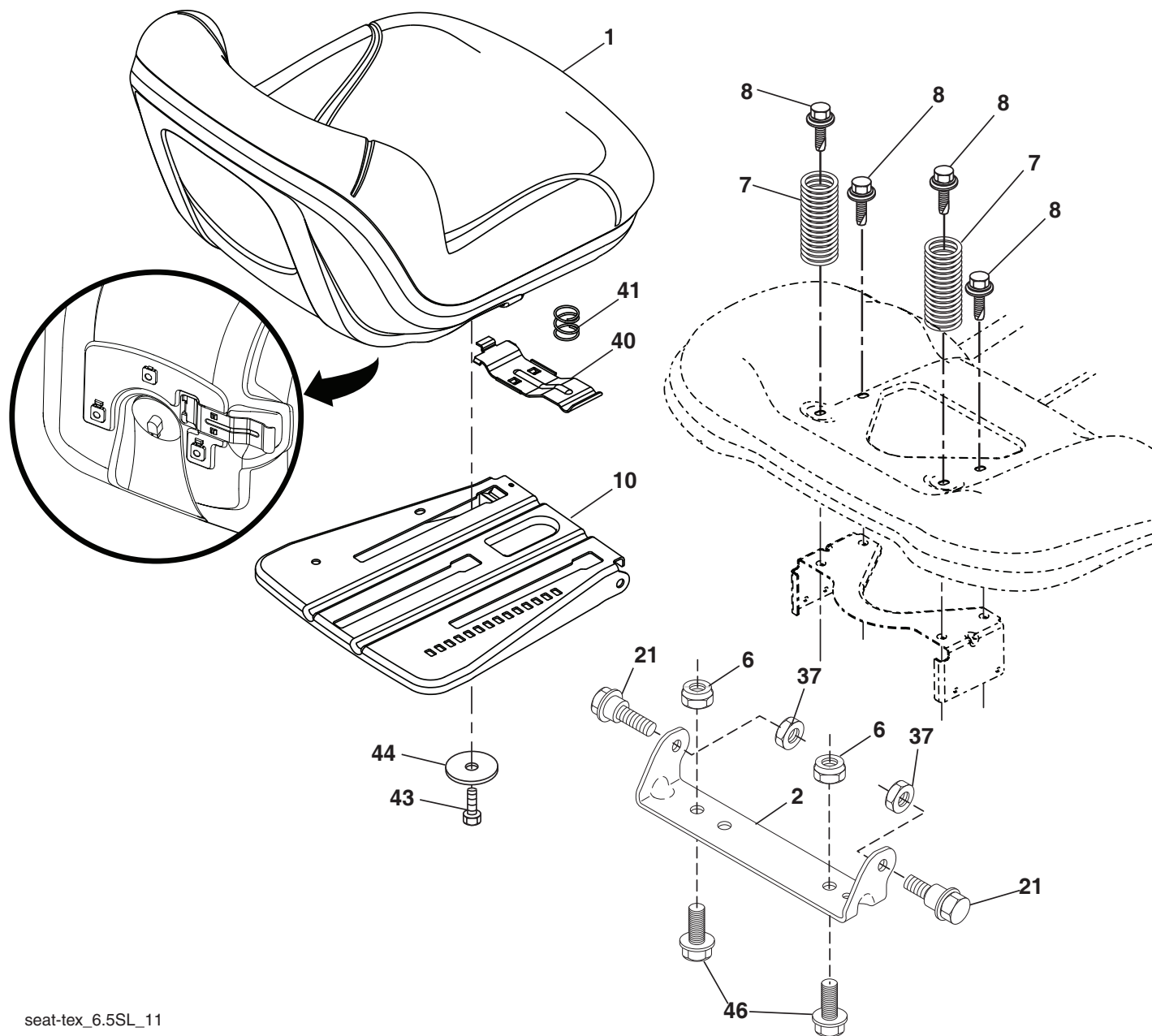

seat-tex_6.5SL_11

KEY PART NO.	NO.	DESCRIPTION
1	532 43 98-22	Seat
2	532 18 01-66	Bracket Pivot Fender
6	873 80 06-00	Nut, Lock w/Ins. 3/8-16 unc
7	587 61 33-01	Spring, Seat Cprsn
8	532 17 18-77	Bolt 5/16-18 unc x 3/4 w/Sems
10	532 19 69-77	Pan, Seat
21	587 90 78-01	Bolt, Shoulder 5/16-18 x 5/8
37	873 80 05-00	Nut, Lock 5/16-18 unc

KEY PART NO.	NO.	DESCRIPTION
40	532 43 98-71	Handle Slide Seat
41	532 19 82-00	Spring Latch Seat
43	874 76 06-12	Bolt Fin Hex 3/8-16 unc x 3/4
44	819 13 38-12	Washer 13/32 x 2-3/8 x 12 Ga.
46	588 09 04-01	Bolt 3/8-16 x 1, 1.25 OD

NOTE: All component dimensions given in U.S. inches
1 inch = 25.4 mm.

**TRACTOR - MODEL NO. YT42DXLS (96043022000), PROD. NO. 960 43 02-20
DECALS**

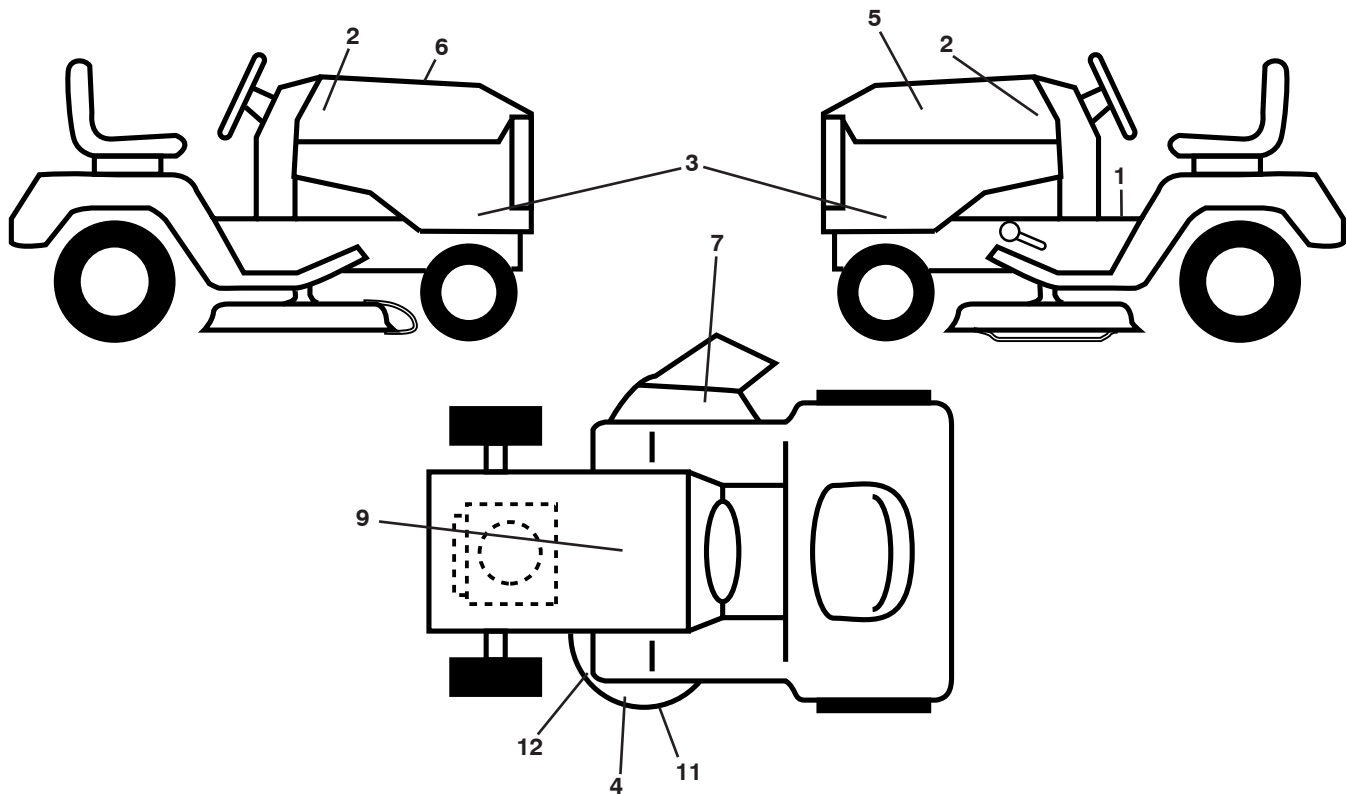

**KEY PART
NO. NO.**

KEY PART NO.	PART NO.	DESCRIPTION
1	581 57 89-01	Decal, Warning
2	581 62 73-01	Badge, Hood
3	587 89 28-01	Decal, Side Panel
4	581 72 43-01	Decal, No Step
5	532 42 38-29	Decal, Warning
6	582 14 21-01	Decal, Replacement
7	586 97 88-01	Decal, Warning
9	532 14 50-05	Decal, Battery Dnge/Poi
11	532 44 81-21	Decal, HV
12	581 58 00-01	Decal, Deck Sch

**KEY PART
NO. NO.**

KEY PART NO.	PART NO.	DESCRIPTION
--	501 74 90-01	Decal, Drawbar Locking Differential
--	581 72 48-01	Decal, Bypass
--	532 43 96-81	Pad, Footrest, LH
--	532 43 96-82	Pad, Footrest, RH
--	115 81 00-27	Manual, Oper.'s (English/Spanish)
--	115 81 01-96	Manual, Parts (English/Spanish)
--	587 71 00-26	Manual Quick Start Guide (English/Spanish)

WHEELS AND TIRES

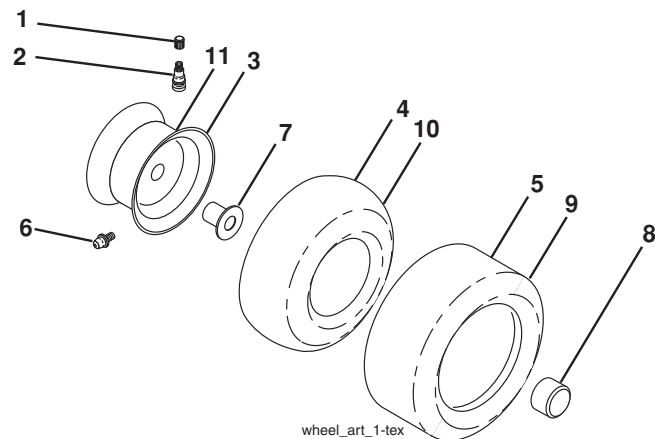

**KEY PART
NO. NO.**

KEY PART NO.	PART NO.	DESCRIPTION
1	532 05 91-92	Cap Valve Tire
2	532 06 51-39	Stem Valve
3	532 13 83-36	Rim Front Service
4	532 00 81-34	Tube Front (Service Item Only)
5	532 17 04-55	Tire Front 15 x 6-6
6	532 12 49-57	Fitting Grease (Front Wheel Only)
7	532 12 49-59	Bearing Flange (Front Wheel Only)
8	532 17 50-39	Cap Axle Blk 1 50 x 1 00
9	532 17 04-56	Tire Rear 20 x 10-8
10	532 12 49-26	Tube Rear (Service Item Only)
11	532 13 83-37	Rim Asm 8" Rear Service
--	532 14 43-34	Sealant, Tire (10 oz. Tube)

NOTE: All component dimensions given in U.S. inches
1 inch = 25.4 mm.

TRACTOR - MODELO NO. YT42DXLS (96043022000), PROD. NO. 960 43 02-20 DIAGRAMA

SCH12-s

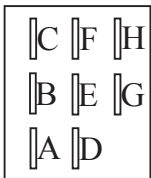
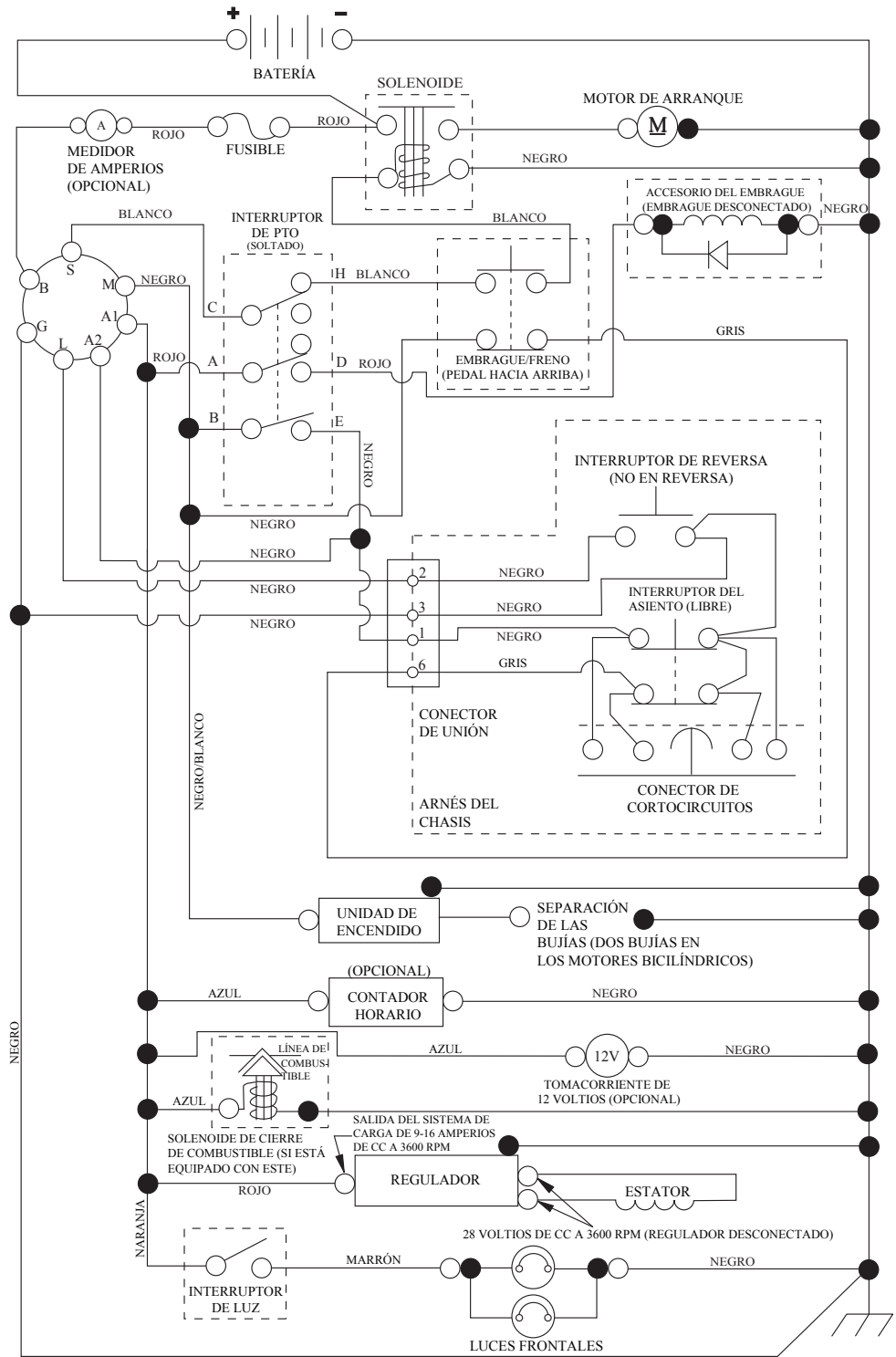

INTERRUPTOR DE PTO
(CARA DE ACOPLAMIENTO)

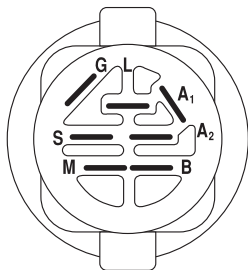

INTERRUPTOR DE ENCENDIDO

POSICIÓN	CIRCUITO «MARCA»
APAGADO	M+G+A1
PONER EN FUNCIONAMIENTO ANULAR	B+A1
PONER EN FUNCIONAMIENTO	B+A1 L+A2
ARRANCAR	B + S + A1

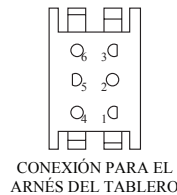

NOTA SOBRE LAS ABRAZADERAS DE AISLAMIENTO DEL CABLEADO: SI SE QUITAN LAS ABRAZADERAS DE AISLAMIENTO DEL CABLEADO PARA HACER EL MANTENIMIENTO DE LA UNIDAD, SE LAS DEBERÁ INSTALAR NUEVAMENTE PARA PROTEGER EL CABLEADO ADECUADAMENTE.



TRACTOR - MODELO NO. YT42DXLS (96043022000), PROD. NO. 960 43 02-20
DIAGRAMA ELÉCTRICO

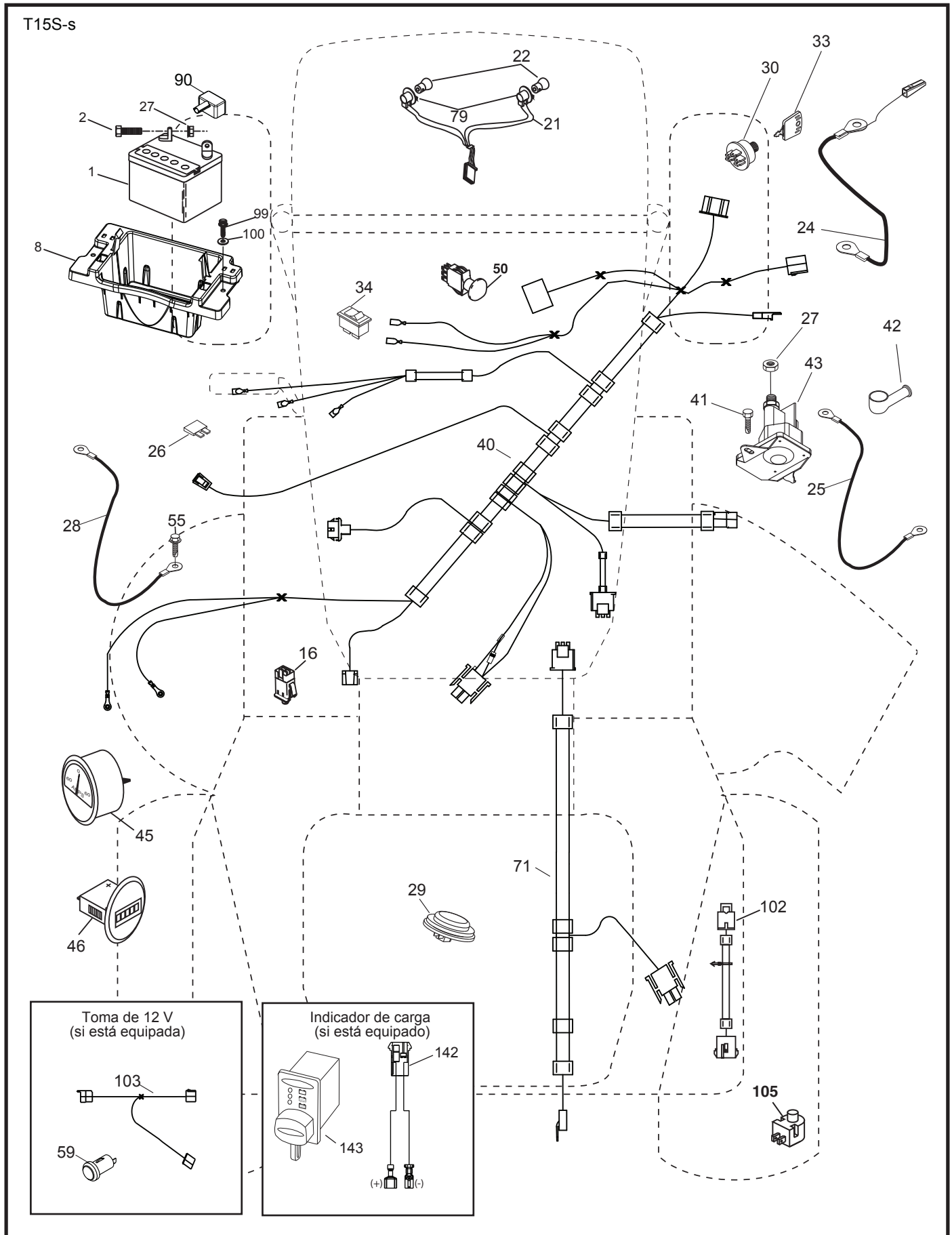

**TRACTOR - MODELO NO. YT42DXLS (96043022000), PROD. NO. 960 43 02-20
DIAGRAMA ELÉCTRICO**

CÓDIGO NO.	PIEZA NO.	DESCRIPCIÓN
1	532 16 34-65	Batería
2	874 76 04-12	Perno de cabeza hexagonal de 1/4-20 x 3/4
8	587 20 51-01	Caja de la batería
16	532 17 61-38	Interruptor corta corriente a presión
21	532 40 02-52	Cableado del enchufe para la luz
22	532 00 41-52	Bombilla de luz
24	585 55 56-01	Cable
25	585 55 55-01	Cable
26	532 17 51-58	Fusible
27	873 51 04-00	Tuerca hexagonal Keps de 1/4-20 unc
28	532 41 65-88	Cable a tierra
29	532 40 15-45	Interruptor del asiento
30	532 19 33-50	Interruptor de encendido
33	532 41 19-33	Llave/cadena
34	532 11 07-12	Interruptor de luz/de restauración
40	501 13 31-01	Cableado de encendido
41	817 72 04-08	Tornillo
42	532 13 15-63	Cubierta de la terminal
43	532 19 25-07	Solenoides
45	587 55 39-03	Indicador SRVCMNDR
46	587 55 40-03	Indicador HRMTR
50	532 17 46-51	Interruptor
55	817 06 05-12	Tornillo de 5/16-18 x 3/4
59	532 40 03-03	Enchufe, 12V
71	532 19 42-76	Cableado de encendido, chasis
79	532 17 52-42	Enchufe de cierre por torsión del ensamble de la bombilla
90	532 43 53-95	Tapa de los bornes de la batería
99	817 67 04-12	Tornillo 1/4-20 x 3/4
100	819 09 14-16	Arandela
102	532 40 44-54	Cable
103	532 42 17-47	Cable 12V
105	532 40 75-68	Interruptor Reverso
142	583 85 78-01	Cableado de conector de carga
143	532 44 80-59	Conector de carga

NOTA: Las dimensiones de todos los componentes están expresadas en pulgadas americanas. 1 pulgada = 25,4 mm

TRACTOR - MODELO NO. YT42DXLS (96043022000), PROD. NO. 960 43 02-20
CHASIS

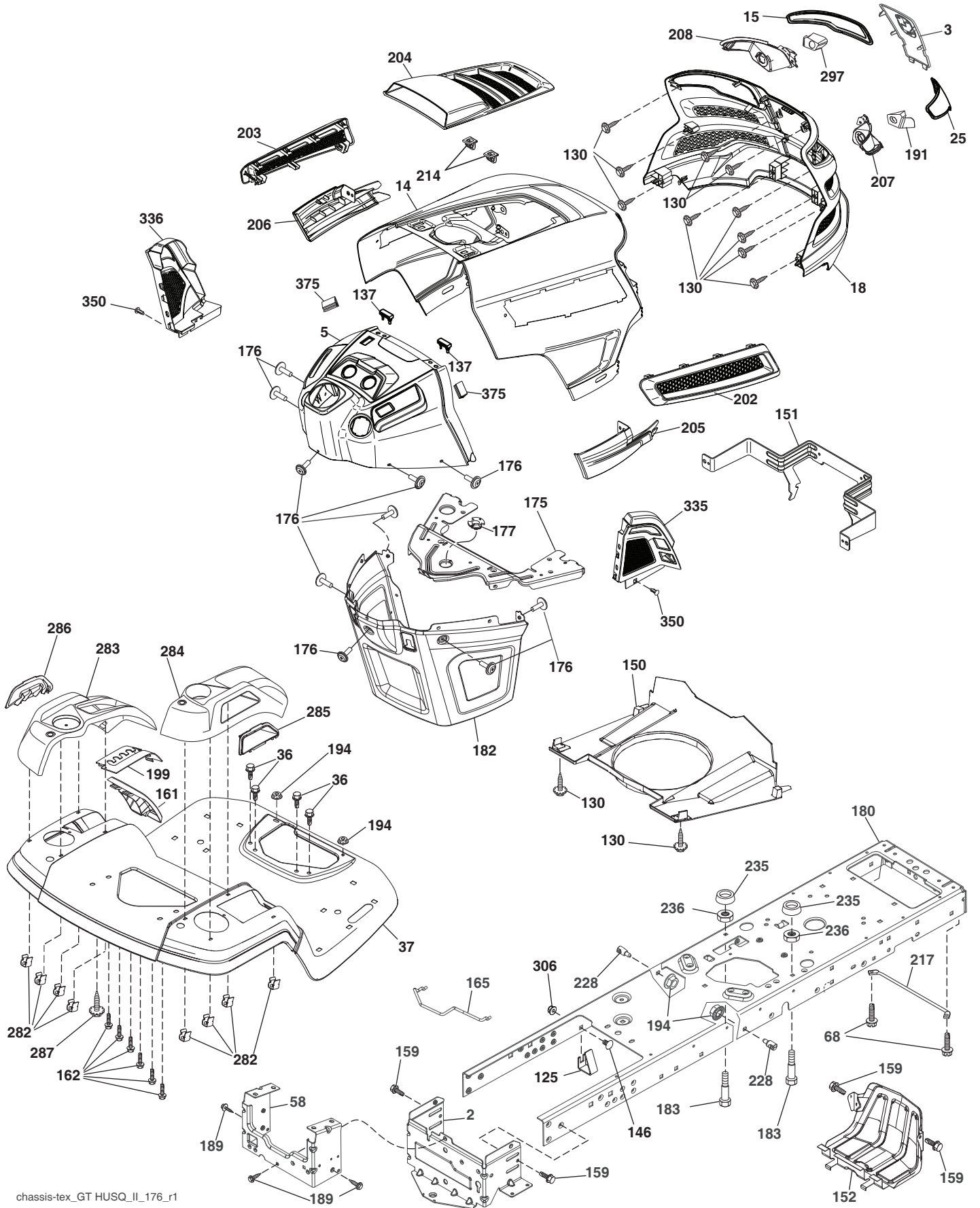

TRACTOR - MODELO NO. YT42DXLS (96043022000), PROD. NO. 960 43 02-20 CHASIS

CÓDIGO NO.	PIEZA NO.	DESCRIPCIÓN	CÓDIGO NO.	PIEZA NO.	DESCRIPCIÓN
2	532 41 22-82	Barra de tracción	199	532 41 34-85	Chapa
3	532 44 44-81	Aplica Submontaje	202	532 43 97-28	Salida de Ventilación (LD)
5	501 74 71-01	Tablero	203	532 43 97-27	Salida de Ventilación (LI)
14	532 44 11-77	Capota	204	532 43 57-14	Salida de Ventilación superior
15	532 43 97-33	Lente izquierdo de la parrilla	205	532 43 97-30	Camisa (LD)
18	532 44 06-53	Parrilla	206	532 43 97-29	Camisa (LI)
25	532 44 33-85	Lente derecho de la parrilla	207	532 43 97-34	Bisel derecho
36	817 06 05-12	Tornillo de 5/16-18 x 3/4	208	532 43 97-35	Bisel izquierdo
37	532 44 11-78	Guardabarros	214	532 19 91-45	Cierre
58	532 41 22-80	Soporte de Guardabarros	217	532 40 91-67	Varilla giratoria
68	817 49 05-08	Tornillo de 5/16-18 x 1/2	228	532 19 51-61	Sujetador del travesaño
125	581 68 48-01	Soporte	235	532 40 61-29	Separador del guardabarros
130	532 41 63-58	Tornillo No. 10 x 0,75	236	873 93 05-00	Tuerca de presión 5/16-18 unc
137	532 40 75-90	Cubierta Tablero	282	532 41 41-10	Pinzas de retención
146	581 85 79-01	Perno	283	532 43 98-61	Consola de la plataforma de elevación
150	532 43 97-74	Cubierta	284	532 43 98-23	Consola cambio
151	532 43 66-70	Soporte de Capota	285	532 41 63-15	Consola inserto (LD)
152	532 43 98-70	Protector contra oscurecimiento	286	532 41 63-17	Consola inserto (LI)
159	817 00 06-12	Tornillo 3/8-16 x 3/4	287	817 60 04-06	Tornillo 1/4-20 X 3/8
161	532 43 97-81	Ventanilla de combustible	297	532 43 74-56	Parte movable reflexivo (LI)
162	532 14 24-32	Tornillo	306	873 90 06-00	Tuerca
165	532 19 43-30	Soporte de Tanque de Gasolina	335	532 44 82-04	Cubierta de Fermeture (LD)
175	532 19 63-04	Travesaño	336	532 44 53-09	Cubierta de Fermeture (LI)
176	532 40 07-76	Tornillo de 10-24 x 5/8	350	532 44 51-43	Cierre del árbol de navidad
177	532 19 52-28	Buje de dirección	375	586 90 82-01	Cubierta Capota
180	532 44 55-59	Chasis	--	532 43 18-82	Protector del cepillo
182	532 40 68-59	Tablero inferior			
183	874 52 05-20	Perno 5/16-18 x 1-1/4			
189	817 00 05-12	Tornillo			
191	532 43 74-55	Parte movable reflexivo (LD)			
194	873 90 05-00	Tuerca de presión de 5/16-18			

NOTA: Las dimensiones de todos los componentes están expresadas en pulgadas americanas. 1 pulgada = 25,4 mm

TRACTOR - MODELO NO. YT42DXLS (96043022000), PROD. NO. 960 43 02-20

TRANSMISIÓN

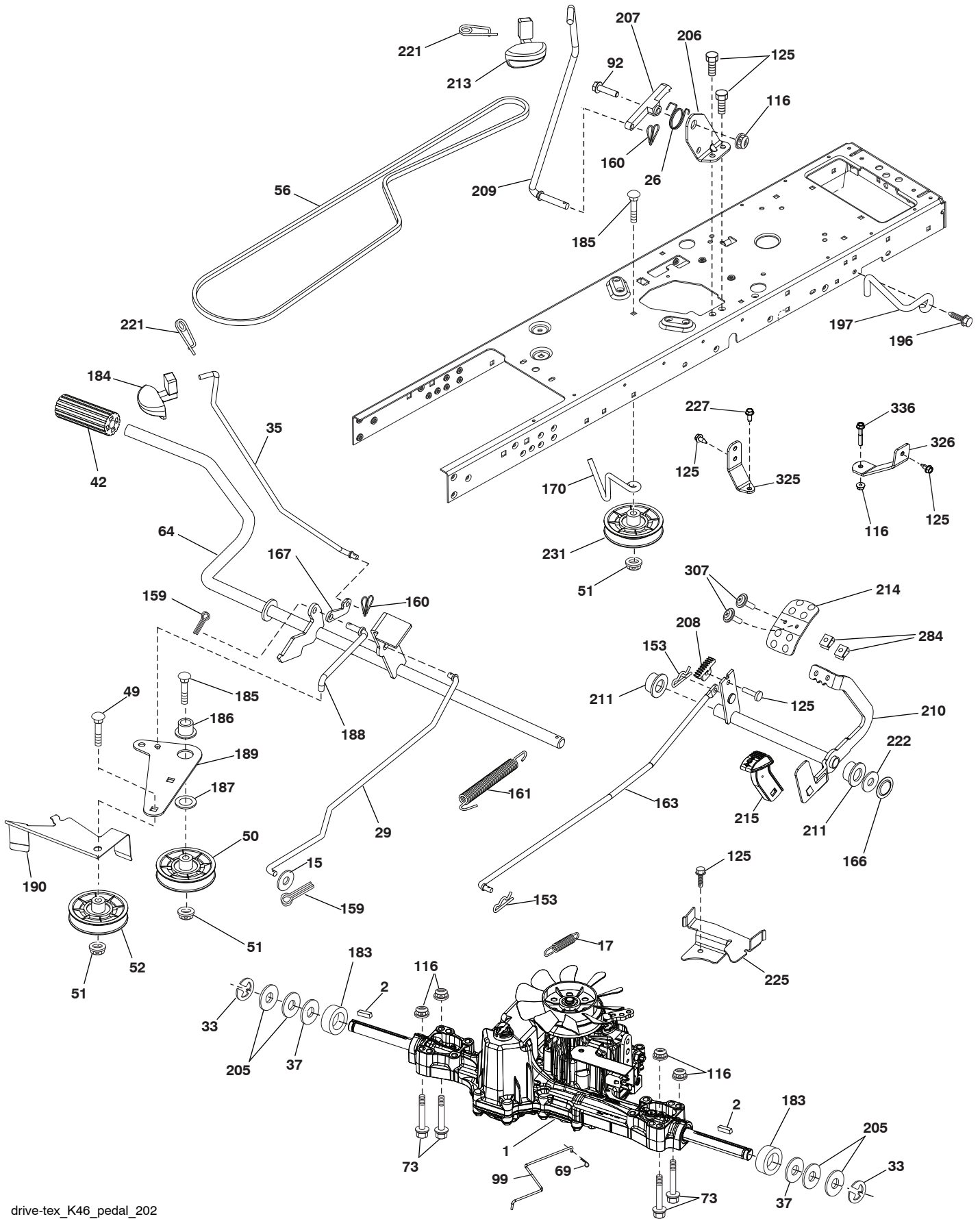

drive-tex_K46_pedal_202

TRACTOR - MODELO NO. YT42DXLS (96043022000), PROD. NO. 960 43 02-20

TRANSMISIÓN

CÓDIGO NO.	PIEZA NO.	DESCRIPCIÓN	CÓDIGO NO.	PIEZA NO.	DESCRIPCIÓN
1	---	Transeje, TUFFTORQ K46 CR (501051401) (Haga el pedido de las piezas al fabricante del transeje.)	186	532 19 43-21	Espaciador de retención
2	532 12 35-83	Llave	187	819 13 32-10	Arandela
15	819 13 13-16	Arandela 13/32 x 13/16 x calibre 16	188	582 21 70-01	Mecanismo de desplazamiento de la varilla de mando del embrague
17	532 41 36-78	Resorte de freno	189	532 19 43-17	Palanca acodada del mecanismo de desplazamiento
26	532 19 96-79	Resorte de travesía	190	532 19 43-18	Sujetador de la palanca acodada del mecanismo de desplazamiento
29	532 40 38-06	Varilla del freno	196	817 00 06-16	Tornillo 3/8-16 x 1
33	812 00 00-01	Aro "E"	197	587 40 20-01	Mecanismo de desplazamiento
35	583 86 45-01	Varilla del freno de mano	205	532 12 17-48	Tuerca
37	532 18 89-67	Tuerca	206	532 44 85-96	Soporte de la travesía
42	532 12 48-72	Cubierta del pedal	207	587 03 14-01	Cierre del control de travesía
49	872 11 06-14	Perno	208	532 19 78-69	Travesía del control del sector
50	532 19 43-27	Polea loca plana	209	532 19 95-92	Travesía del control de Rod
51	873 90 06-00	Tuerca de presión de 3/8-16	210	532 40 09-80	Ensamble del pedal
52	532 19 43-26	Polea loca con ranura en V con un desplazamiento	211	532 12 01-83	Buje
56	532 13 09-69	Correa trapezoidal de la transmisión	213	532 40 31-19	Travesía del control de la perilla
64	532 19 78-65	Ensamble del eje Control del pedal de freno	214	532 41 68-63	Pedal adelante
69	532 42 33-03	Clavija	215	586 60 65-02	Revés del pedal
73	874 49 05-40	Perno 5/16-18	221	532 40 31-87	Abrazadera de retención del resorte de la manija
92	874 76 05-20	Tornillo 5/16-18 x 1/2	222	879 21 20-10	Tuerca 21/32 x 1-1/4 x calibre 10
99	582 40 45-01	Varilla de desviación	225	532 40 33-19	Sujetador de la correa transeje
116	873 90 05-00	Tuerca 5/16-18	227	817 49 05-12	Tornillo 5/16-18 x 3/4
125	817 00 05-12	Tornillo 5/16-18 x 3/4	231	532 40 72-87	Polea loca con ranura en V con un desplazamiento
153	532 12 47-88	Retén del resorte	284	532 41 76-93	Tuerca 1/4-20
159	876 02 04-12	Pasador de chaveta de 1/8 x 3/4	307	874 18 04-12	Tornillo 1/4-20 x 3/4
160	532 16 94-84	Abrazadera de retención	325	586 43 12-02	Soporte
161	532 10 57-09	Resorte de retorno del embrague	326	586 00 11-02	Soporte
163	532 44 82-75	Control del pedal de la barra	336	587 25 96-01	Perno
166	532 42 91-64	Tuerca			
167	532 40 52-57	Pestillo del freno de mano			
170	532 41 34-30	Sujetador de la correa central			
183	532 13 70-57	Separador			
184	587 65 37-01	Manija del freno de mano			
185	872 11 06-22	Tornillo 3/8-16 x 2-3/4 G5			

NOTA: Las dimensiones de todos los componentes están expresadas en pulgadas americanas. 1 pulgada = 25,4 mm

**TRACTOR - MODELO NO. YT42DXLS (96043022000), PROD. NO. 960 43 02-20
MOTOR**

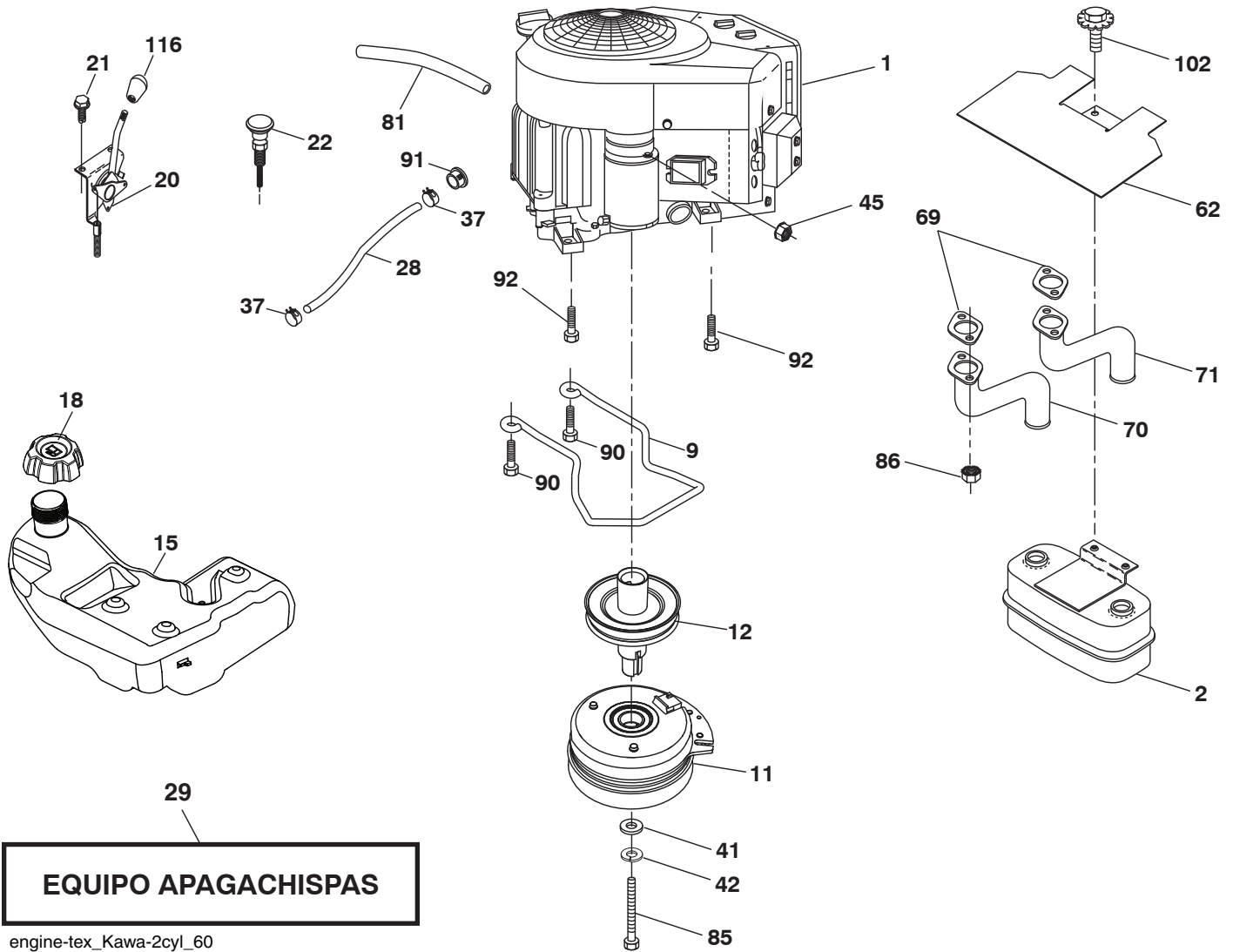

**TRACTOR - MODELO NO. YT42DXLS (96043022000), PROD. NO. 960 43 02-20
MOTOR**

CÓDIGO NO.	PIEZA NO.	DESCRIPCIÓN
1	---	Motor Kawa Modelo No. FR651-AS28 (581411101) (Piezas de la orden del fabricante del motor.)
2	589 81 87-01	Silenciador
9	501 83 26-01	Ensamble del sujetador de la correa del motor
11	587 25 50-01	Embrague eléctrico
12	586 89 96-01	Polea del motor
15	532 43 30-25	Tanque de combustible
18	585 12 48-01	Ensamble de la tapa
20	532 42 43-41	Control del regulador
21	532 41 63-58	Tornillo No. 10 x 0,75
22	532 18 95-41	Control del obturador
28	532 40 11-35	Línea de combustible
29	532 13 71-80	Equipo apagachispas
37	532 12 34-87	Abrazadera de la manguera
41	532 12 61-97	Arandela 1-1/2 x 15/32 x .250
42	810 04 07-00	Arandela de presión de 7/16
45	873 51 04-00	Tuerca
62	532 43 40-17	Silenciador con pantalla térmica
69	532 17 81-51	Junta
70	583 95 56-01	Tubo de escape izquierdo
71	583 95 57-01	Tubo de escape derecho
81	532 14 84-56	Tubo de dren del aceite
92	817 12 06-16	Tornillo 3/8-16 x 1
85	871 17 07-80	Perno de 7/16-20 x 5
86	532 18 43-62	Tuerca
90	817 00 06-16	Tornillo 3/8-16 x 1
91	532 18 74-95	Buje
92	817 12 06-16	Tornillo 3/8-16 x 1
102	817 00 05-12	Tornillo 5/16-18 x 3/4
116	539 13 26-24	Perilla

NOTA: Las dimensiones de todos los componentes están expresadas en pulgadas americanas. 1 pulgada = 25,4 mm

Para las piezas del servicio y de recambio del motor, llame el número gratis para su fabricante del motor enumerado abajo:

Kawasaki 1-949-460-5688

TRACTOR - MODELO NO. YT42DXLS (96043022000), PROD. NO. 960 43 02-20
ENSAMBLE DE LA DIRECCIÓN

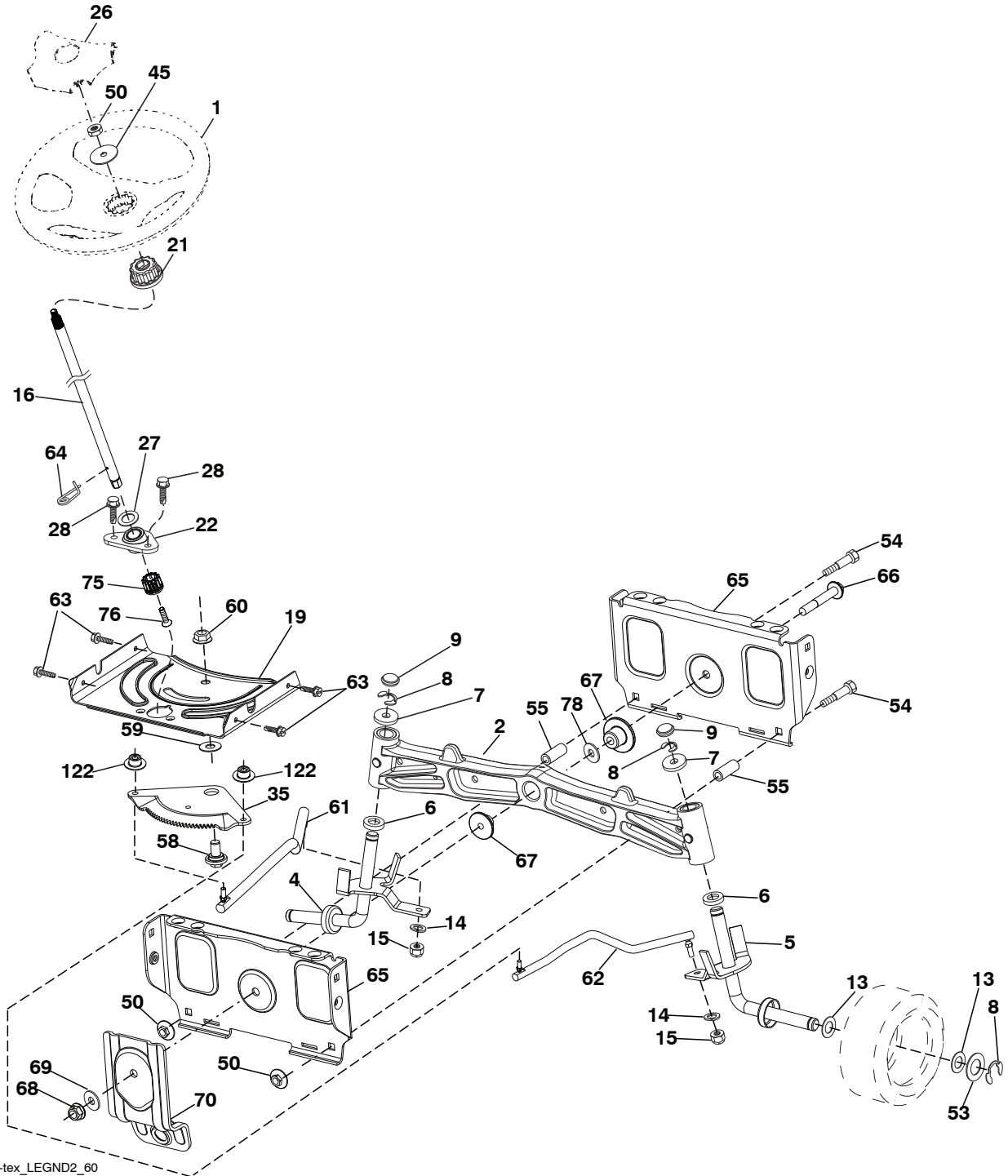

Steering-tex_LEGND2_60

**TRACTOR - MODELO NO. YT42DXLS (96043022000), PROD. NO. 960 43 02-20
ENSAMBLE DE LA DIRECCIÓN**

CÓDIGO NO.	PIEZA NO.	DESCRIPCIÓN
1	532 43 97-40	Volante de dirección
2	532 19 59-68	Ensamble del eje delantero
4	586 72 40-01	Ensamble del husillo izquierdo
5	586 72 41-01	Ensamble del husillo derecho
6	532 12 49-31	Pista del rodamiento para reforzar el impulso
7	532 12 17-48	Arandela de 25/32 x 1-5/8 calibre 16
8	812 00 00-29	Abrazadera del aro No. T5304-75
9	532 12 12-32	Tapa del husillo
13	532 12 17-49	Arandela de 25/32 x 1-1/4 calibre 16
14	810 04 06-00	Arandela de presión de 3/8
15	873 54 06-00	Tuerca de 3/8-24 unf
16	587 01 60-02	Eje de dirección
19	532 19 47-29	Placa de dirección
21	586 84 02-01	Adaptador del volante de dirección
22	585 02 98-02	Rodamiento
26	532 43 97-43	Inserto del volante de dirección
27	819 21 16-16	Arandela
28	817 00 06-12	Tornillo de 3/8-16 x 3/4
35	532 19 47-32	Engranaje del sector de la placa
45	587 01 64-01	Arandela 3/8 ID 2-3/8 OD calibre 12 PLTD
50	873 90 06-00	Tuerca 3/8-16 unc
53	532 18 89-67	Arandela reforzada de 793 x 1637 x 0,060
54	874 76 06-36	Tornillo 3/8-16 unc x 2-1/4
55	532 41 47-36	Tornillo 3/8-16 unc x 2-1/4
58	532 19 47-47	Perno de tope del sector del pivote CFM
59	532 19 47-48	Arandela de empuje del sector de dirección
60	873 97 10-00	Tuerca de 5/8-11
61	532 19 47-40	Barra de acoplamiento izquierda
62	532 19 47-41	Barra de acoplamiento derecha
63	817 00 05-12	Tornillo de 5/16-18 x 3/4
64	532 19 98-49	Abrazadera de retención del resorte de la dirección
65	532 19 47-34	Apoyo del árbol delantero
66	871 02 07-48	Perno de cabeza hexagonal con brida acanalada de 7/16-14 x 3
67	532 19 47-37	Buje PM del eje delantero
68	873 90 07-00	Tuerca de 7/16-14 grado 5
69	532 19 91-62	Arandela de 1,5 x 0,505 x 0,118
70	585 33 88-01	Soporte de la plataforma delantera
75	580 68 37-01	Piñón
76	580 68 36-01	Tornillo
78	532 05 70-79	Tuerca
122	532 44 49-62	Tapa

NOTA: Las dimensiones de todos los componentes están expresadas en pulgadas americanas. 1 pulgada = 25,4 mm

TRACTOR - MODELO NO. YT42DXLS (96043022000), PROD. NO. 960 43 02-20
PLATAFORMA DE LA CORTADORA DE CÉSPED

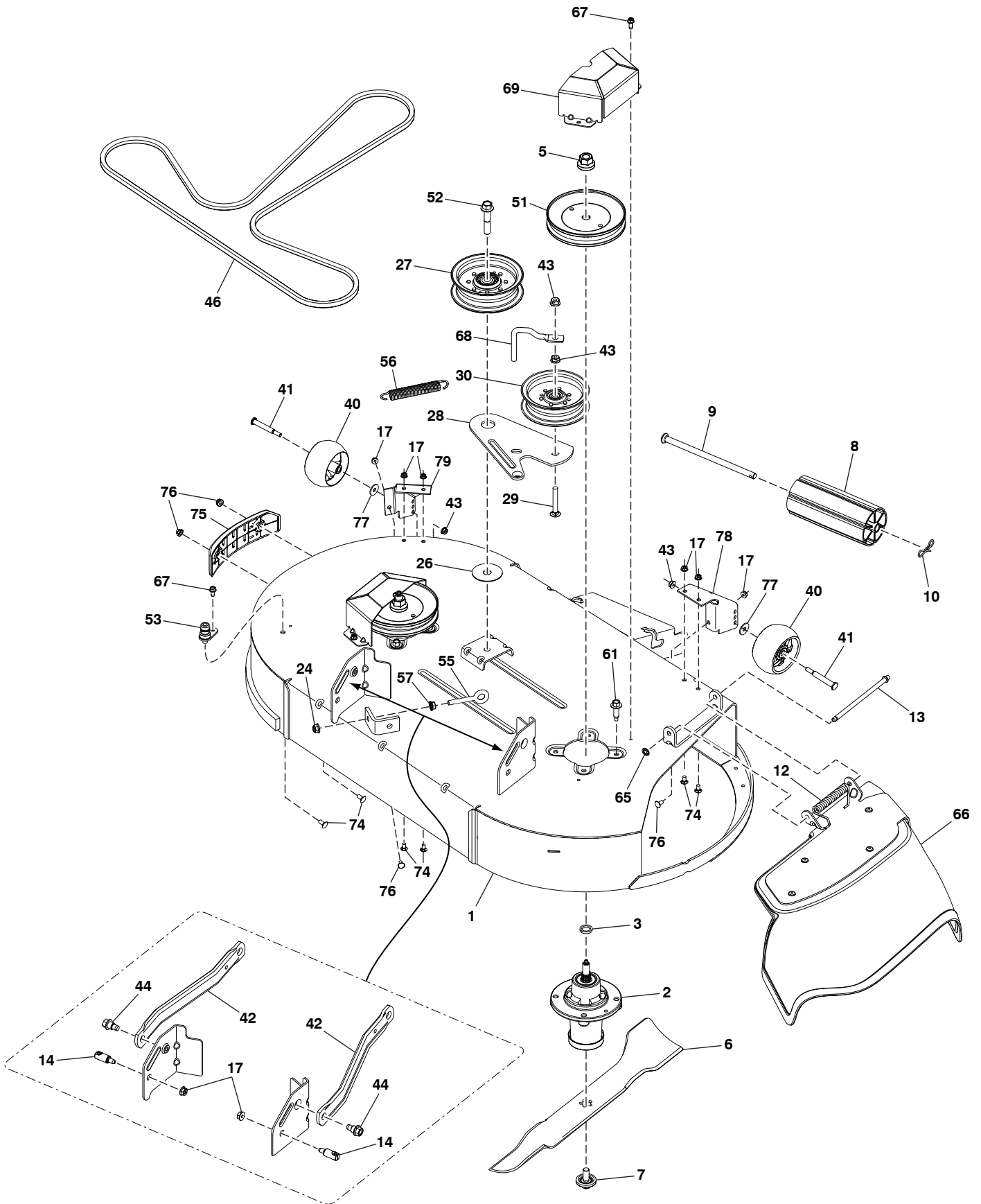

**TRACTOR - MODELO NO. YT42DXLS (96043022000), PROD. NO. 960 43 02-20
PLATAFORMA DE LA CORTADORA DE CÉSPED**

CÓDIGO NO.	PIEZA NO.	DESCRIPCIÓN
1	589 02 90-02	Carcasa de la cortadora de césped
2	539 11 21-70	Carcasa de mandril
3	539 18 76-90	Arandela
5	539 10 75-90	Tuerca 9/16
6	586 91 81-01	Cuchilla
7	532 19 30-03	Perno 7/16
8	532 17 60-66	Mida la rueda
9	532 17 91-27	Varilla de la bisagra
10	532 19 42-08	Retorno del resorte
12	587 35 47-01	Resorte
13	532 13 14-91	Varilla 42/46/48/54
14	532 19 51-61	Perno
17	873 90 05-00	Tuerca 5/16-18
24	539 11 28-99	Tuerca 5/16-18
26	532 17 85-15	Arandela
27	532 19 61-04	Polea loca
28	586 87 40-02	Brazo 42FCS
29	872 14 06-20	Perno
30	532 19 61-06	Polea loca
40	532 17 48-73	Calibrador de la rueda
41	532 19 34-06	Perno
42	532 19 51-85	Brazo de la suspensión
43	873 90 06-00	Tuerca 3/8-15 unc
44	532 19 65-39	Perno
46	587 27 01-01	Correa 42 FCS
51	532 19 97-91	Polea del mandril
52	588 43 83-01	Tornillo 7/16-14 x 2.125
53	532 41 55-98	Puerto de lavado de la cubierta
55	539 11 55-74	Perno 5/16 x 3-1/2
56	587 35 84-01	Retorno del resorte
57	539 99 05-85	Tuerca 5/16-18
61	584 95 39-01	Perno
65	532 11 04-52	Tuerca
66	587 30 57-01	Ensamble del deflector 42 FCS
67	532 13 77-29	Tornillo
68	532 19 84-68	Sujetador de la correa
69	586 93 68-05	Cubierta del mandril 42"
74	872 11 05-05	Perno 5/16-18 x 5/8
75	579 81 10-01	Cubierta
76	585 93 81-01	Tuerca
77	819 13 20-12	Arandela calibre 12
78	501 80 83-02	Soporte del calibrador de la rueda LD
79	590 43 90-02	Soporte del calibrador de la rueda LI
--	532 41 64-05	Accesorio del conexión
--	582 16 51-01	Reemplazo de la cortadora de césped, completa

NOTA: Las dimensiones de todos los componentes están expresadas en pulgadas americanas. 1 pulgada = 25,4 mm

TRACTOR - MODELO NO. YT42DXLS (96043022000), PROD. NO. 960 43 02-20
ELEVACIÓN DE LA CORTADORA DE CÉSPED

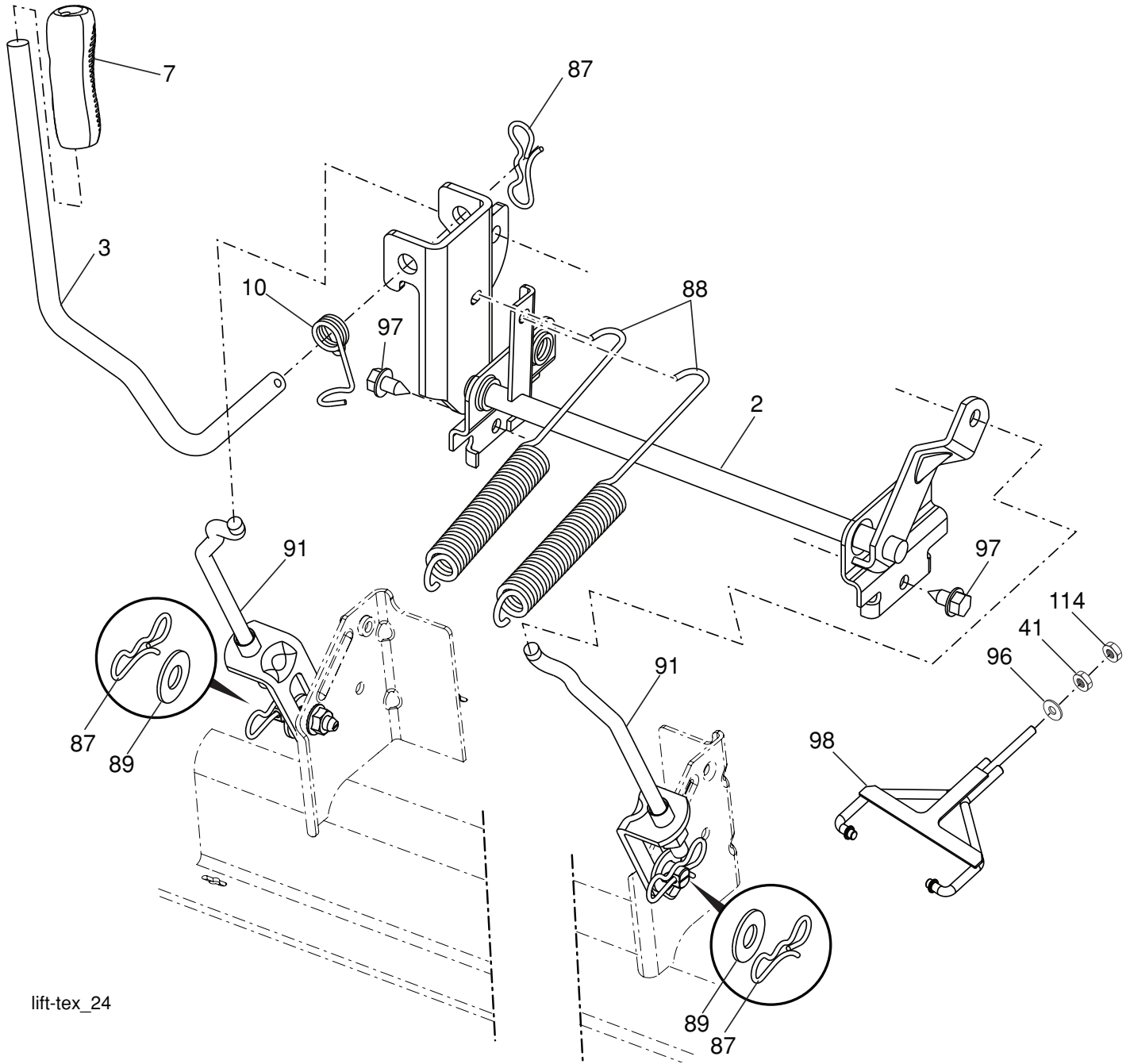

lift-tex_24

CÓDIGO NO.	PIEZA NO.	DESCRIPCIÓN
2	532 42 20-27	Ensamble del eje de la elevación
3	532 19 52-31	Ensamble de la palanca de elevación derecha
7	580 96 23-01	Mango de la palanca
10	532 19 63-14	Resorte de torsión
41	532 17 59-94	Tuerca
87	532 19 42-09	Pasador de chaveta de 7/16 con bloqueo en forma de mariposa
88	532 41 07-10	Resorte de ayuda de la elevación
89	819 19 19-12	Arandela de zinc transparente

CÓDIGO NO.	PIEZA NO.	DESCRIPCIÓN
91	532 40 34-07	Ensamble del acoplamiento Elevación trasera
96	532 19 52-63	Buje
97	817 00 06-12	Tornillo de 3/8-16 x 0,75
98	574 82 25-01	Acoplamiento frontal de la elevación de la cortadora de césped
114	873 36 07-00	Tuerca 7/16-20

NOTA: Las dimensiones de todos los componentes están expresadas en pulgadas americanas. 1 pulgada = 25,4 mm

TRACTOR - MODELO NO. YT42DXLS (96043022000), PROD. NO. 960 43 02-20 ENSAMBLE DEL ASIENTO

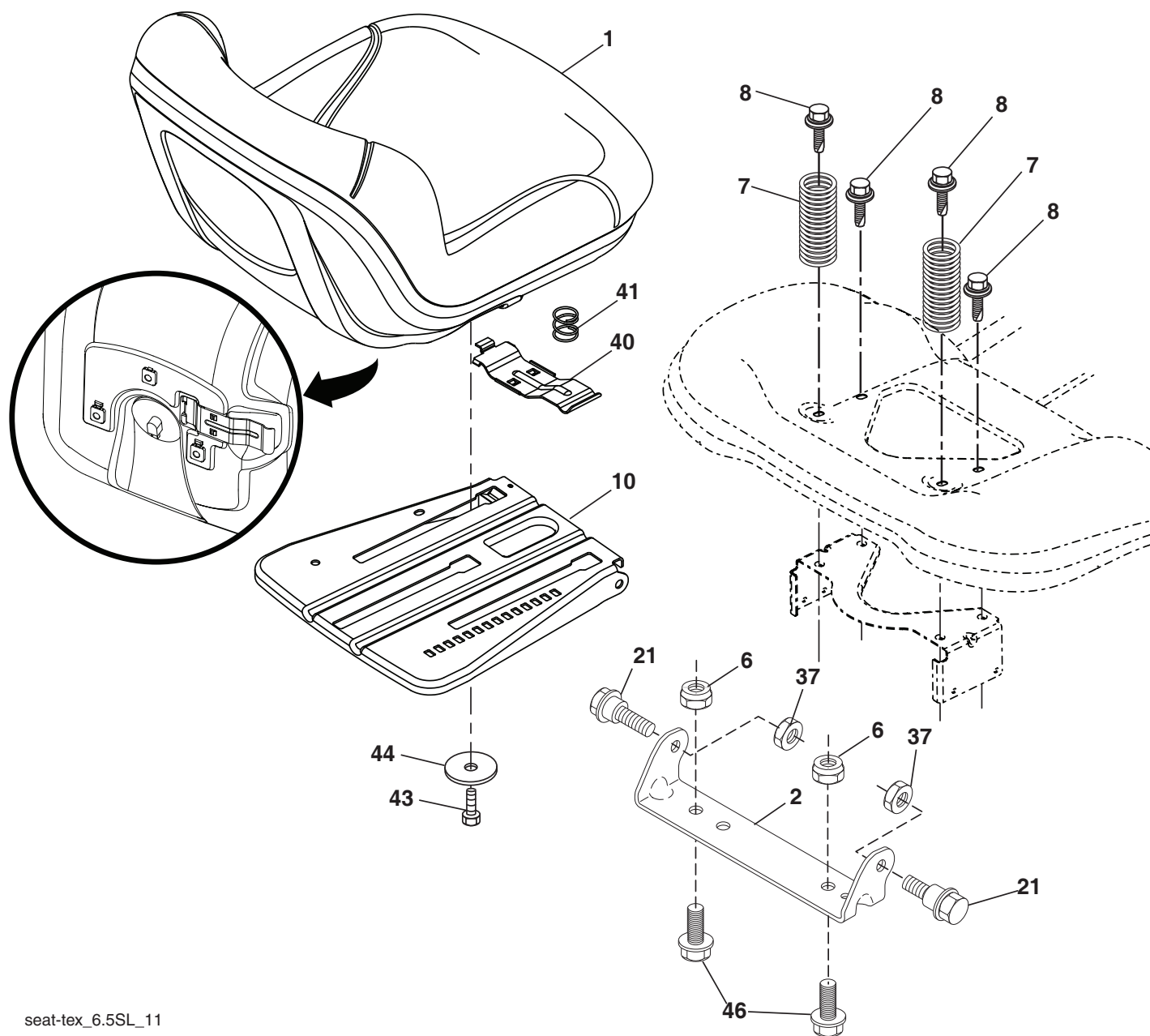

seat-tex_6.5SL_11

CÓDIGO NO.	PIEZA NO.	DESCRIPCIÓN
1	532 43 98-22	Asiento
2	532 18 01-66	Soporte pivotante del guardabarros
6	873 80 06-00	Tuerca de presión c/aislamiento de 3/8-16 unc
7	587 61 33-01	Resorte del asiento
8	532 17 18-77	Perno de 5/16" unc x 3/4"
10	532 19 69-77	Bandeja del asiento
21	587 90 78-01	Perno de tope de 5/16-18 x 5/8
37	873 80 05-00	Tuerca de presión de 5/16-18 unc
40	532 43 98-71	Manija para deslizar el asiento

CÓDIGO NO.	PIEZA NO.	DESCRIPCIÓN
41	532 19 82-00	Resorte para trabar el asiento
43	874 76 06-12	Perno de cabeza hexagonal con aleta de 3/8-16 unc x 3/4
44	819 13 38-12	Arandela de 13/32 x 2-3/8 calibre 12
46	588 09 04-01	Perno 3/8-16 x 1, 1.25 OD

NOTA: Las dimensiones de todos los componentes están expresadas en pulgadas americanas. 1 pulgada = 25,4 mm

**TRACTOR - MODELO NO. YT42DXLS (96043022000), PROD. NO. 960 43 02-20
CALCOMANÍAS**

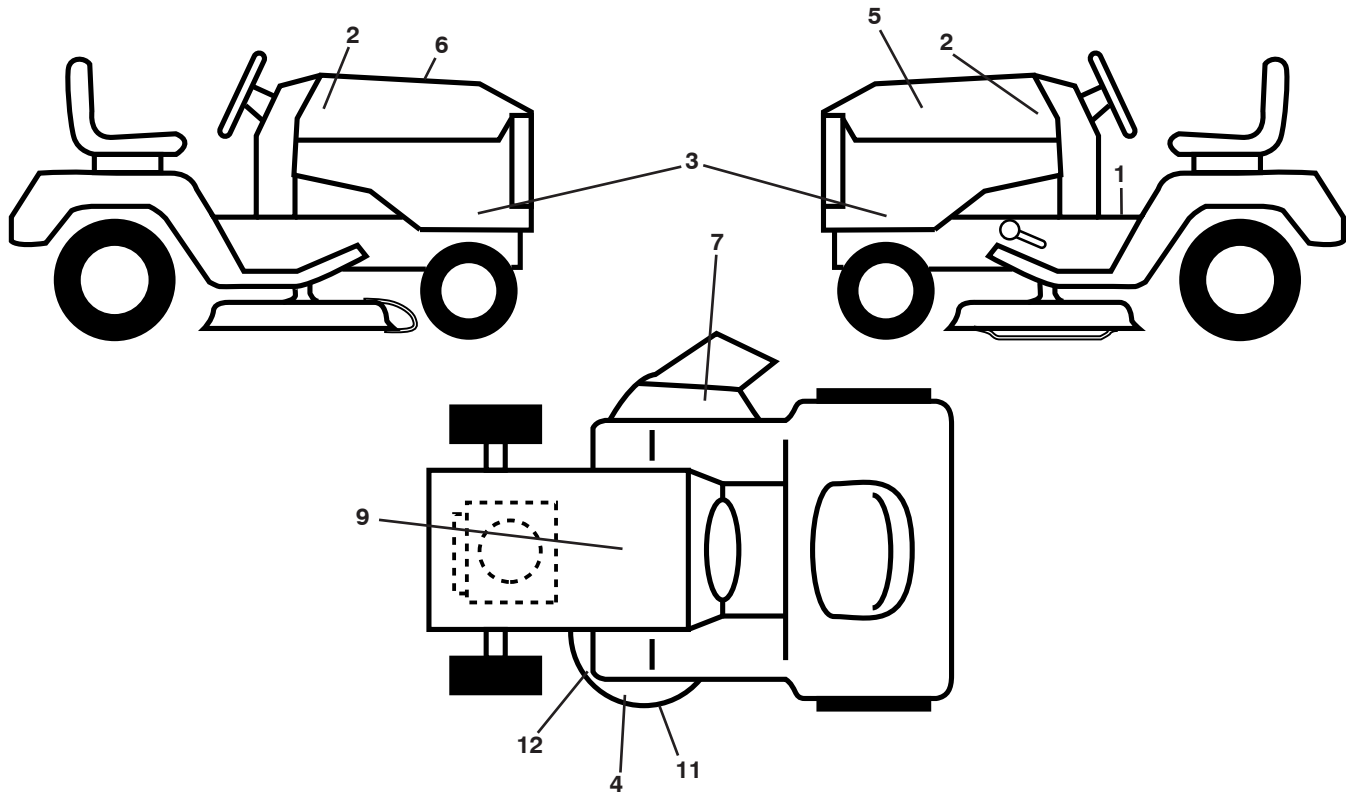

CÓDIGO NO.	PIEZA NO.	DESCRIPCIÓN
1	581 57 89-01	Calcomanía Advertencia
2	581 62 73-01	Calcomanía para el insignia
3	587 89 28-01	Calcomanía para el panel lateral
4	581 72 43-01	Calcomanía ningun n paso
5	532 42 38-29	Calcomanía Advertencia
6	582 14 21-01	Calcomanía de reemplazo
7	586 97 88-01	Calcomanía Advertencia
9	532 14 50-05	Calcomanía de Peligro/Punto de interconexión
11	532 44 81-21	Calcomanía reforzado de cubierta
12	581 58 00-01	Calcomanía diagrama de la cubierta

CÓDIGO NO.	PIEZA NO.	DESCRIPCIÓN
--	501 74 90-01	Calcomanía diferencial de bloqueo
--	581 72 48-01	Calcomanía para la desviación
--	532 43 96-81	Forro del apoyo para los pies (LD)
--	532 43 96-82	Forro del apoyo para los pies (LI)
--	115 81 00-27	Manual del operario (Inglés/Español)
--	115 81 01-96	Manual del repuestos (Inglés/Español)
--	587 71 00-26	Manual, Guía de inicio rápido (Inglés/Español)

RUEDAS Y NEUMÁTICOS

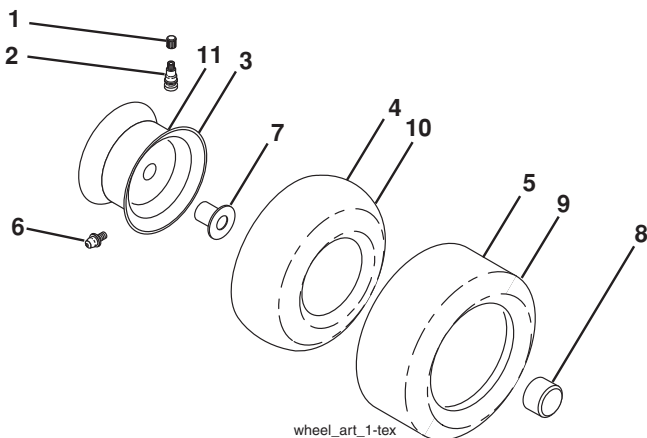

CÓDIGO NO.	PIEZA NO.	DESCRIPCIÓN
1	532 05 91-92	Tapa de la válvula del neumático
2	532 06 51-39	Vástago de la válvula
3	532 13 83-36	Ensamble de las llantas delanteras
4	532 00 81-34	Cámara delantera
5	532 17 04-55	Neumático delantero 15 x 6-6
6	532 12 49-57	Accesorio para engrasar (solo para la rueda delantera)
7	532 12 49-59	Rodamiento de la brida (solo para la rueda delantera)
8	532 17 50-39	Tapa del eje (solo para la rueda delantera)
9	532 17 04-56	Neumático trasero 20 x 10-8
10	532 12 49-26	Cámara trasera (Mantenimiento sólo)
11	532 13 83-37	Ensamble trasero de la llanta
--	532 14 43-34	Sellador para neumáticos (tubo de 10 onzas [283 gr])

NOTA: Las dimensiones de todos los componentes están expresadas en pulgadas americanas. 1 pulgada = 25,4 mm

NOTES/AVISO



www.husqvarna.com