

Repair Parts Manual
Manual De Repuestos
LTH1738 / 96043024800

Please read the operator's manual carefully and make sure you understand the instructions before using the machine.

Por favor lea cuidadosamente y comprenda estas instrucciones antes de usar esta maquina.



English/Spanish

115 93 65-49 Rev. 5



HOW TO USE THIS MANUAL

This manual is designed to provide the customer with a means to identify the parts on his/her tractor when ordering repair parts. The illustrations may or may not represent the actual assemblies; therefore, it is not recommended to use this manual as a guide to assemble or disassemble the tractor. Some hardware and parts are drawn larger in order to more readily identify them.

Each tractor has its own model number. The model number for your tractor can be found on the fender under the seat.

Support / Help

If you require assistance or have questions concerning the application, operation, maintenance or parts for your product:

- Visit our website: www.husqvarna.com
- Call Us Toll Free: 1-800-487-5951

When ordering parts, always give the following information:

- Product - "TRACTOR"
- MODEL NUMBER - "LTH1738" (96043024800)"
- Part Number
- Part Description

TABLE OF CONTENTS

SCHEMATIC	3
ELECTRICAL	4-5
CHASSIS	6-7
DRIVE	8-9
ENGINE	10-11
STEERING	12-13
MOWER DECK	14-15
MOWER LIFT	16
SEAT	17
DECALS	18
ENGINE BREAKDOWN	36-37

COMO UTILIZAR ESTE MANUAL

Este manual está diseñado para brindarle al comprador un medio para identificar las piezas del tractor para cuando necesite hacer el pedido de un repuesto. Las ilustraciones pueden o no representar los ensambles reales; por lo tanto, no se recomienda utilizar este manual como una guía para ensamblar o desarmar el tractor. Algunos accesorios y piezas están dibujados en tamaños más grandes para identificarlos con mayor facilidad.

Cada tractor tiene su propio número de modelo. El número de modelo del tractor se encuentra en el guardabarros debajo del asiento.

Soporte / Ayuda

Si necesita asistencia o tiene alguna pregunta acerca de la aplicación, operación, mantenimiento o piezas de su producto:

- Visite nuestro sitio web: www.husqvarna.com
- Llámenos de manera gratuita al: 1-800-487-5951

Cuando haga el pedido de una pieza, siempre brinde la siguiente información:

- Producto: "TRACTOR"
- NÚMERO DE MODELO: "LTH1738" (96043024800)"
- Número de pieza
- Descripción de la pieza

ÍNDICE

DIAGRAMA	19
DIAGRAMA ELÉCTRICO	20-21
CHASIS	22-23
TRANSMISIÓN	24-25
MOTOR	26-27
DIRECCIÓN	28-29
PLATAFORMA DE LA CORTADORA DE CÉSPED	30-31
ELEVACIÓN DE LA CORTADORA DE CÉSPED	32
ASIENTO	33
CALCOMANÍAS	34
MOTOR DESCOMPOSTURA	38-39

TRACTOR - MODEL NO. LTH1738 (96043024800), PRODUCT NO. 960 43 02-48 SCHEMATIC

SCH11

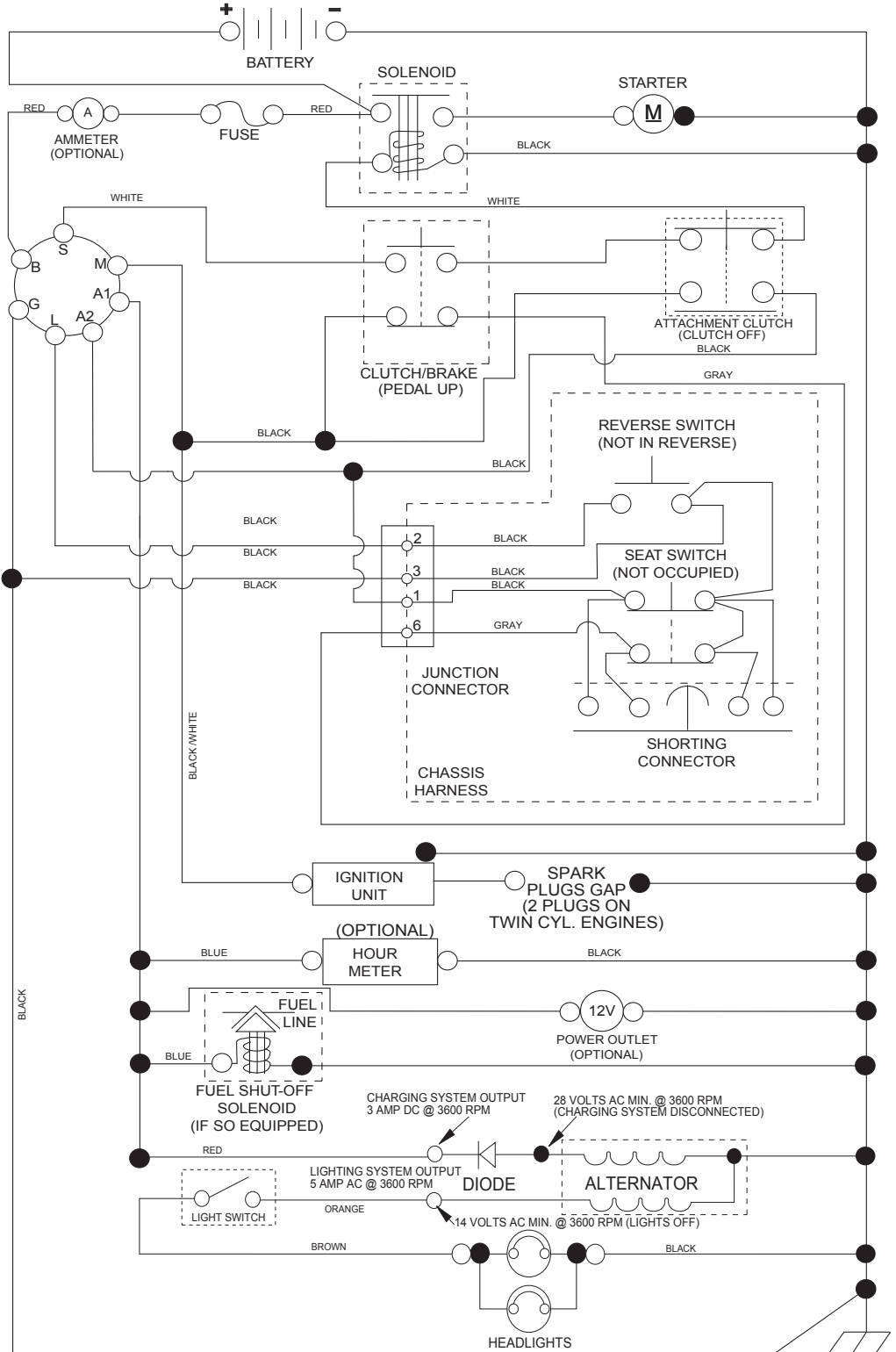

NOTE
YOUR TRACTOR IS EQUIPPED WITH A SPECIAL ALTERNATOR SYSTEM. THE LIGHTS ARE NOT CONNECTED TO THE BATTERY, BUT HAVE THEIR OWN ELECTRICAL SOURCE. BECAUSE OF THIS, THE BRIGHTNESS OF THE LIGHTS WILL CHANGE WITH ENGINE SPEED. AT IDLE THE LIGHTS WILL DIM. AS THE ENGINE IS SPEEDED UP, THE LIGHTS WILL BECOME THEIR BRIGHTEST.

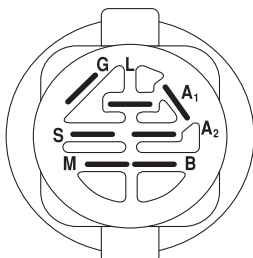

IGNITION SWITCH

POSITION	CIRCUIT "MAKE"
OFF	M+G+A1
RUN/OVERRIDE	B+A1
RUN	B+A1 L+A2
START	B+S+A1

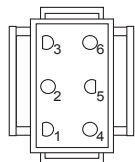

CHASSIS HARNESS CONNECTOR (MATING SIDE)

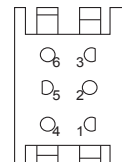

DASH HARNESS CONNECTOR (MATING SIDE)

WIRING INSULATED CLIPS
NOTE: IF WIRING INSULATED CLIPS WERE REMOVED FOR SERVICING OF UNIT, THEY SHOULD BE RE-INSTALLED TO PROPERLY SECURE YOUR WIRING.

NON-REMOVABLE CONNECTIONS

REMOVABLE CONNECTIONS

**TRACTOR - MODEL NO. LTH1738 (96043024800), PRODUCT NO. 960 43 02-48
ELECTRICAL**

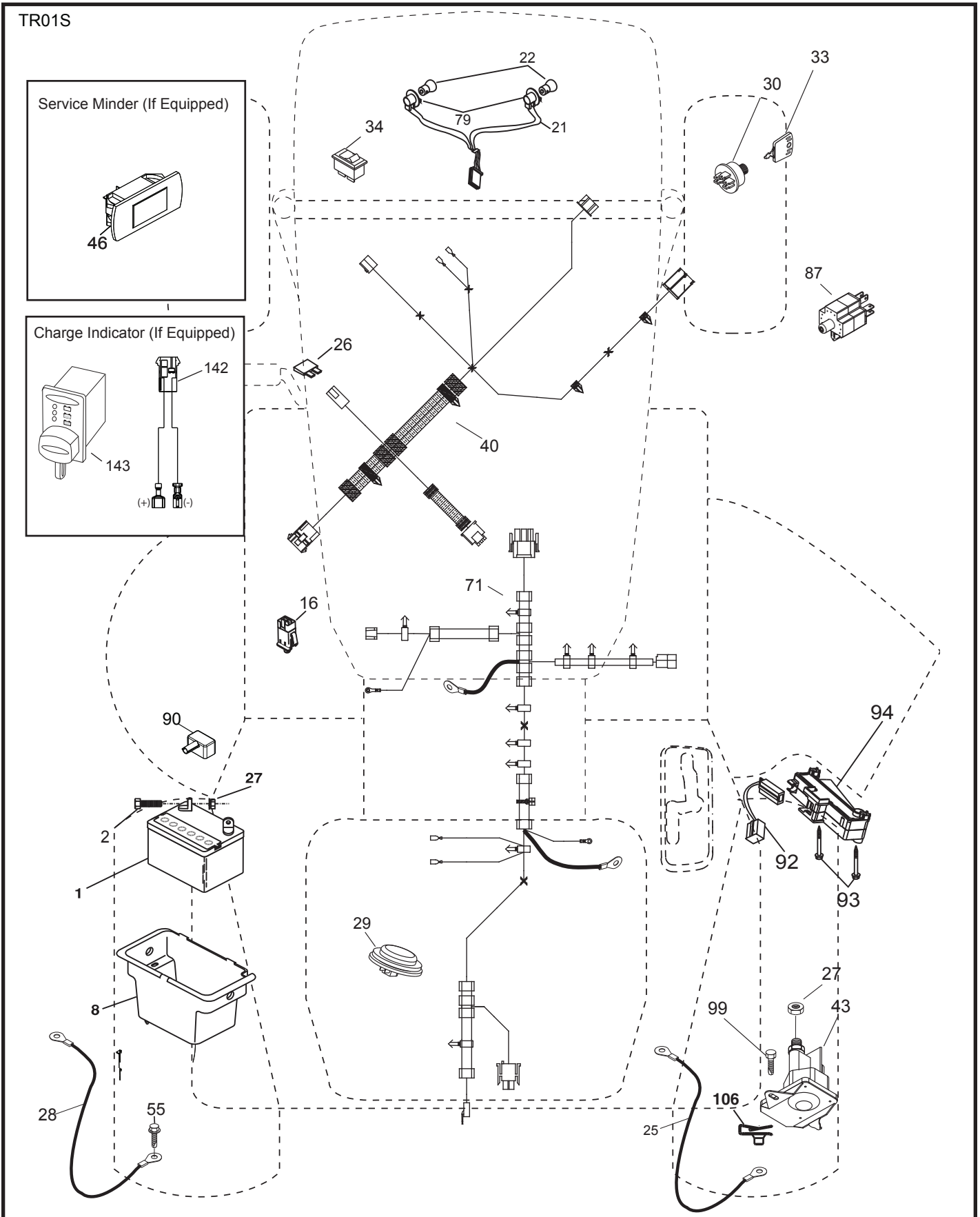

**TRACTOR - MODEL NO. LTH1738 (96043024800), PRODUCT NO. 960 43 02-48
ELECTRICAL**

KEY NO.	PART NO.	DESCRIPTION
1	532 16 34-65	Battery
2	874 76 04-12	Bolt Hex Head 1/4-20 x 3/4
8	532 19 32-28	Box Battery
16	532 17 61-38	Switch Interlock Push-In
21	532 40 02-52	Harness Socket Light w/4152J
22	532 00 41-52	Bulb Light
25	581 49 80-01	Cable Starter
26	532 17 51-58	Fuse
27	873 51 04-00	Nut Keps Hex 1/4-20 unc
28	532 42 16-86	Cable, Ground
29	532 40 15-45	Switch, Seat
30	532 19 33-50	Switch, Ign
33	532 41 19-33	Key/Chain
34	532 11 07-12	Switch Light/Reset
40	581 02 31-01	Harness Ign. Dash
43	582 04 28-01	Solenoid
55	817 06 05-12	Screw Thdrol 5/16-18 x 3/4
71	501 13 37-01	Harness Chassis
79	532 17 52-42	Socket Asm Bulb Twistlock
87	532 19 78-02	Switch Interlock Clutch Cable
90	532 43 53-95	Cover, Terminal Battery
92	532 19 66-15	Harness Pigtail Console
93	532 19 25-40	Screw Plastite 10-14 x 2.0
94	532 19 18-34	Module Reverse ROS
99	817 67 04-12	Screw
106	532 17 48-14	Pal nut

NOTE: All component dimensions given in U.S. inches
1 inch = 25.4 mm

TRACTOR - MODEL NO. LTH1738 (96043024800), PRODUCT NO. 960 43 02-48
CHASSIS

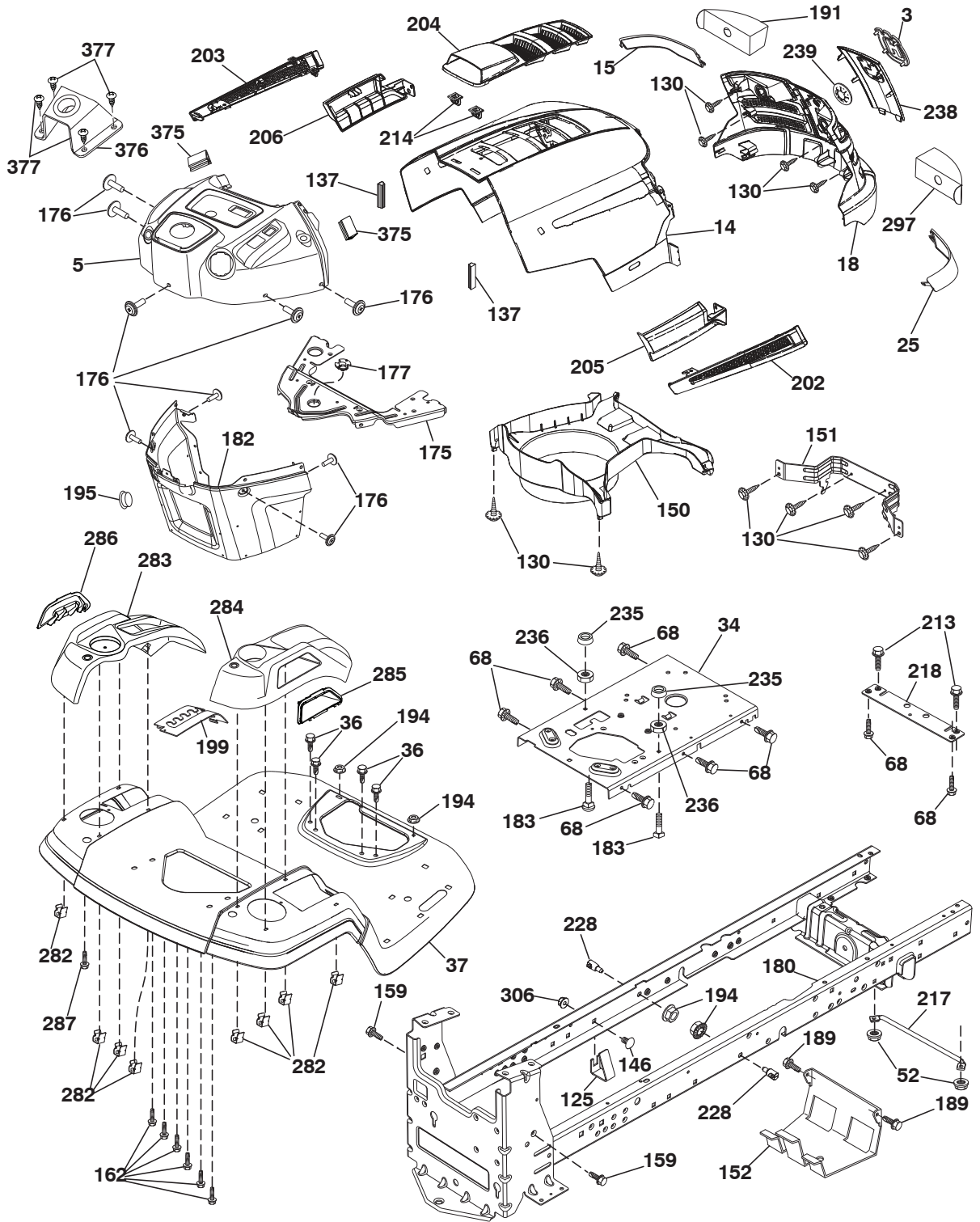

chassis-tex_TEX LT HUSQ_93

**TRACTOR - MODEL NO. LTH1738 (96043024800), PRODUCT NO. 960 43 02-48
CHASSIS**

KEY NO.	PART NO.	DESCRIPTION	KEY NO.	PART NO.	DESCRIPTION
3	581 05 63-01	Logo	202	532 44 13-42	Vent Side Hood RH
5	501 86 11-01	Dash	203	532 44 13-43	Vent Side Hood LH
14	532 44 12-67	Hood	204	532 44 13-75	Vent Top Hood
15	532 44 14-28	Lens LH	205	532 44 13-44	Skirt Side RH
18	532 44 13-68	Grille	206	532 44 13-45	Skirt Side LH
25	532 44 14-27	Lens RH	213	874 76 05-12	Bolt 5/16-18 x 3/4
34	580 91 08-01	Plate Engine	214	532 19 91-45	Clip Retainer
36	817 06 05-12	Screw 5/16-18 x 3/4	217	532 40 91-67	Rod Pivot Hood
37	532 44 12-66	Fender	218	532 19 63-95	X-Piece Hood Stop
52	873 68 05-00	Nut Crown Lock 5/16	228	532 19 51-61	Stud Fastener
68	539 99 08-58	Screw THDROL 5/16-18 x 1/2	235	532 40 61-29	Spacer Fender
125	581 68 48-01	Fuel Line Clip	236	873 93 05-00	Nut Lock 5/16-18 unc
130	532 41 63-58	Screw #10 x 0.750 BOS Thread	238	532 44 13-74	Trim
137	532 40 75-90	Bumper Dash	239	532 40 48-83	Clip Tinnerman
146	581 85 79-01	Bolt 3/8-16 x 5/8 unc	282	532 41 41-10	Clip Retainer
150	532 40 66-62	Air Duct	283	532 43 91-52	Console Asm LH
151	532 40 78-07	Bracket Pivot	284	532 44 41-64	Console RH
152	532 19 95-35	Shield Browning	285	532 41 63-15	Console Insert RH
159	817 00 06-12	Screw Hexwash Thor 3/8-16 x 3/4	286	532 41 63-17	Console Insert LH
162	532 14 24-32	Screw	287	817 60 04-06	Screw Hex Washhead 1/4-20 x 3/8
175	532 19 94-72	Crossmember Plate	297	532 40 66-65	Insert Reflective LH
176	532 40 07-76	Screw 10-24 x 5/8	306	873 90 06-00	Nut Lock Flg 3/8-16 unc
177	532 19 52-28	Bushing Steering	375	586 90 82-01	Dash Clip-On Bumper
180	532 19 54-57	Chassis	376	589 45 87-01	Mount Asm Huslt Upper Strng
182	532 40 71-76	Dash Lower	377	589 45 53-01	Screw 10 x 1/2 ZN PL Phil Pan AB
183	874 52 05-20	Bolt 5/16-18 x 1-1/4 Full Thd			
189	817 00 05-12	Screw			
191	532 41 65-01	Insert Reflective RH			
194	873 90 05-00	Nut Lock Hex Flange 5/16-18			
195	532 43 99-76	Plug Dash			
199	532 41 34-85	Plate Deck Lift			

NOTE: All component dimensions given in U.S. inches
1 inch = 25.4 mm

**TRACTOR - MODEL NO. LTH1738 (96043024800), PRODUCT NO. 960 43 02-48
DRIVE**

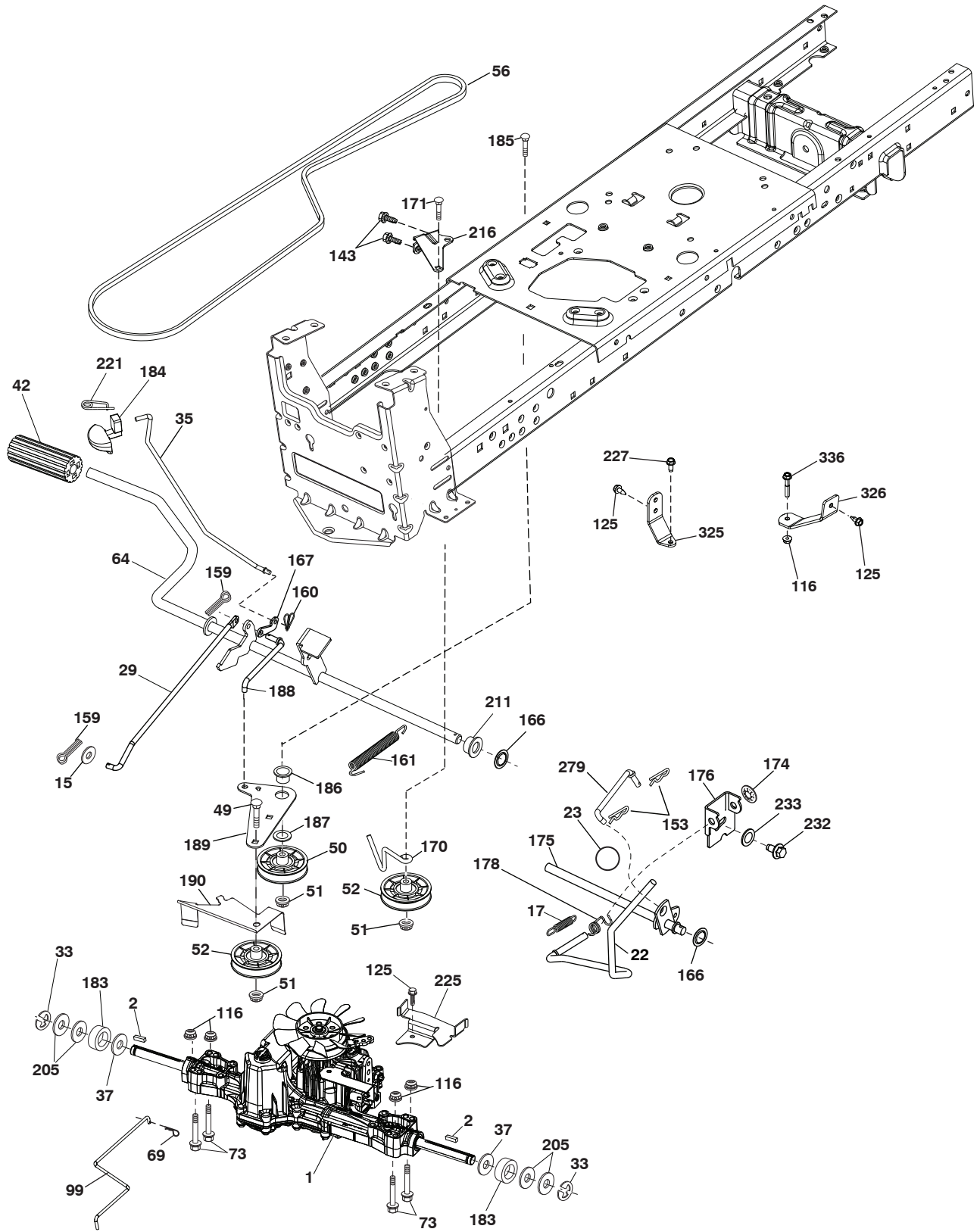

drive-tex_K46_fender_52

**TRACTOR - MODEL NO. LTH1738 (96043024800), PRODUCT NO. 960 43 02-48
DRIVE**

KEY NO.	PART NO.	DESCRIPTION	KEY NO.	PART NO.	DESCRIPTION
1	---	Transaxle, Tufftorq K46BA (448348) (Order parts from transaxle manufacturer.)	170	532 19 43-22	Keeper Belt Centerspan
			171	872 11 06-16	Bolt RD HD SQ NK 3/8-16 unc x 2
2	532 12 35-83	Key Square	174	532 19 72-89	Nut Push
15	819 13 13-16	Washer 13/32 x 13/16 x 16 Ga.	175	532 40 62-08	Shaft Asm Shift
17	532 41 36-78	Spring, Brake	176	532 19 62-14	Arm Clevis Rod Shift
22	532 19 76-60	Rod Shift	178	532 19 74-56	Spring Shift
23	532 14 08-45	Knob	183	532 13 70-57	Spacer Axle
29	532 40 38-06	Rod, Brake	184	532 41 14-84	Handle Parking Brake
33	812 00 00-01	Ring E	185	872 11 06-22	Bolt
35	532 40 10-31	Rod, Brake, Park	186	532 19 43-21	Spacer Retainer
37	532 18 89-67	Washer Harden .793 x 1.637 x 060	187	819 13 32-10	Washer
42	532 12 48-72	Cover, Foot Pedal	188	582 21 70-01	Link Clutch Ground Drive, Long
49	872 11 06-14	Bolt	189	532 19 43-17	Bellcrank Ground Drive
50	532 19 43-27	Pulley Idler Flat	190	532 19 43-18	Keeper Bellcrank Ground Drive
51	873 90 06-00	Lock Nut 3/8-16	205	532 12 17-48	Washer 25/32 x 1-5/8 x 16 Ga.
52	532 19 43-26	Idler V-Groove Offset	211	532 19 62-12	Bushing Shaft
56	532 13 09-69	V-Belt, Drive	216	532 19 61-31	Bracket Pulley Idler
64	532 19 62-00	Shaft Asm. Pedal Brake Control	221	532 40 31-87	Retainer Spring Clip Handle
69	532 42 33-03	Hairpin .059 x 1.125	225	532 40 33-19	Keeper Belt
73	874 49 05-40	Bolt Hex 5/16-18 x 2 1/2 Gr. 5	227	817 49 05-12	Screw THDROL 5/16-18 x 3/4
99	582 40 45-01	Rod Spring Bypass	232	874 78 07-16	Bolt 7/16-14 x 1 Gr 5
116	873 90 05-00	Nut Lock Hex Flange 5/16-18	233	532 40 52-96	Washer Serrated
125	817 00 05-12	Screw 5/16-18 x 3/4	279	532 40 62-07	Link Shift
143	539 99 08-58	Screw THDROL 5/16-18 x 1/2	325	585 66 85-01	Torque Strap LH
153	532 12 47-88	Retainer Spring 1"	326	585 67 08-01	Bracket Torque Strap RH
159	876 02 04-12	Pin Cotter 1/8 x 3/4	336	587 25 96-01	Bolt 5/16-18 x 1-3/4
160	532 16 94-84	Retainer Clip			
161	532 10 57-09	Spring, Return, Clutch			
166	532 42 91-64	Nut Push .625			
167	532 40 52-57	Latch Brake Parking			

NOTE: All component dimensions given in U.S. inches
1 inch = 25.4 mm

TRACTOR - MODEL NO. LTH1738 (96043024800), PRODUCT NO. 960 43 02-48
ENGINE

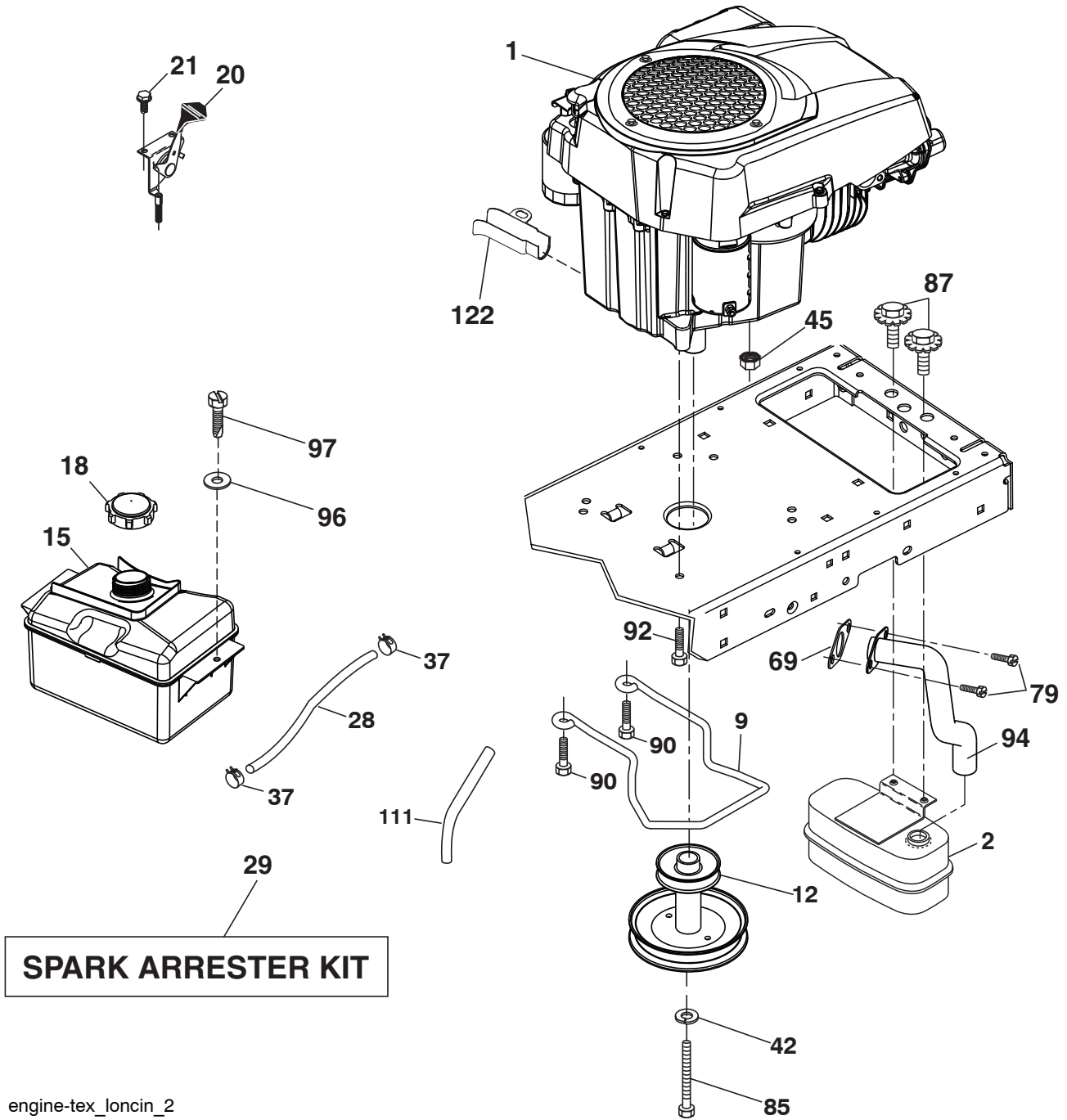

**TRACTOR - MODEL NO. LTH1738 (96043024800), PRODUCT NO. 960 43 02-48
ENGINE**

KEY NO.	PART NO.	DESCRIPTION
1	— — — — —	Engine Husqvarna Model No. LC1P92F-1 (592822601)
2	590 64 53-01	Muffler
9	501 83 26-01	Keeper Belt Engine
12	586 47 85-01	Pulley Engine
15	532 43 30-08	Tank Fuel
18	581 17 61-01	Cap Fuel
20	532 18 38-97	Control Throttle/Choke
21	532 41 63-58	Screw #10 x 0.750 BOS Thread
28	532 40 11-37	Fuel Line
29	532 13 71-80	Spark Arrester Kit
37	532 12 34-87	Clamp Hose
42	539 99 02-47	Washer Lock 7/16 SLW STD.
45	873 51 04-00	Nut Keps Hex 1/4-20 unc
69	590 86 35-01	Gasket
79	532 18 39-06	Screw 5/16-18 x 1 Socket Head
85	501 60 65-01	Bolt Hex 7/16-20 x 4 Gr. 5 1.5
87	532 17 18-77	Bolt 5/16-18 unc x 3/4
90	817 00 06-16	Screw 3/8-16 x 1
92	817 12 06-16	Screw 3/8-16 x 1
94	590 86 47-01	Exhaust Tube
96	819 09 14-16	Washer 9/32 x 7/8 x 16 Ga.
97	817 67 04-12	Screw 1/4-20 x 3/4
111	532 41 41-19	Purge Line
122	532 42 19-22	Extension Drain Oil

NOTE: All component dimensions given in U.S. inches
1 inch = 25.4 mm

TRACTOR - MODEL NO. LTH1738 (96043024800), PRODUCT NO. 960 43 02-48
STEERING ASSEMBLY

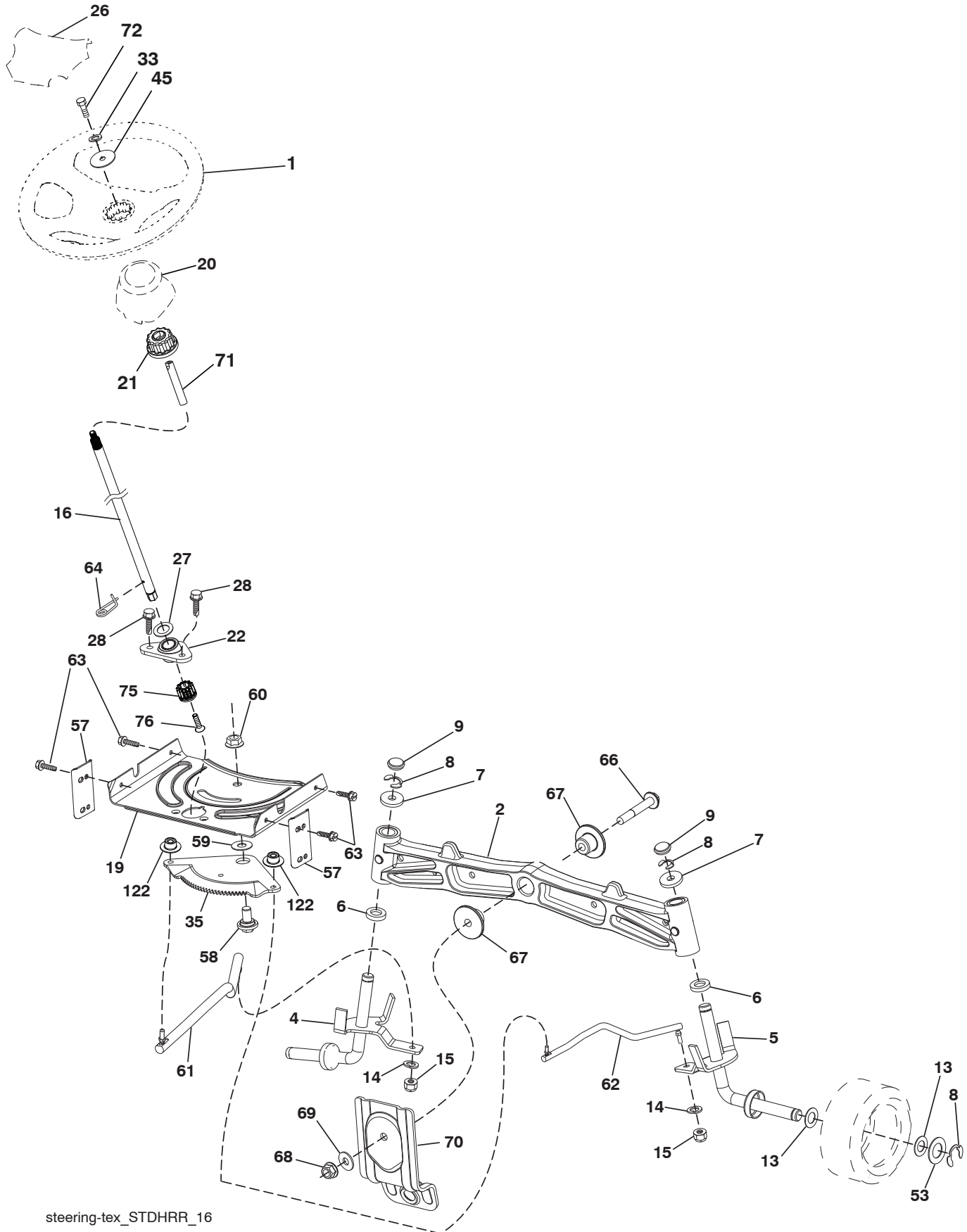

steering-tex_STDHRR_16

**TRACTOR - MODEL NO. LTH1738 (96043024800), PRODUCT NO. 960 43 02-48
STEERING ASSEMBLY**

KEY NO.	PART NO.	DESCRIPTION
1	532 43 97-40	Wheel, Steering
2	532 19 59-68	Axle Asm., Front
4	532 40 30-87	Spindle Asm., LH
5	532 40 30-88	Spindle Asm., RH
6	532 12 49-31	Bearing, Race Thrust Harden
7	532 12 17-48	Washer 25/32 x 1-5/8 x 16 Ga.
8	812 00 00-29	Ring, Klip #T5304-75
9	532 12 12-32	Cap, Spindle
13	532 12 17-49	Washer SLW ZD 3/8
14	539 99 01-18	Washer, Lock Hvy Hlcl Spr 3/8
15	873 54 06-00	Nut, Crown Lock 3/8-24 unf
16	585 86 92-02	Steering Shaft
19	532 19 47-29	Plate Steering
20	532 44 14-25	Boot Steering
21	532 18 67-37	Adapter, Wheel Steering
22	585 02 98-02	Bearing Shaft
26	532 43 97-43	Insert, Wheel Steering
27	819 21 16-16	Washer 21/32 x 1 x 16 Ga.
28	817 00 06-12	Screw 3/8-16 x 3/4
33	539 99 01-87	Lockwasher 5/16
35	532 19 47-32	Gear, Sector Plate
45	819 11 38-12	Washer 11/32 ID x 2 3/8 OD x 12 Ga.
53	532 18 89-67	Washer Hardened .793 x 1.637 x .060
57	532 40 74-65	Bracket Upstop
58	532 19 47-47	Bolt Shoulder Sector Pivot CFM
59	532 19 47-48	Washer Thrust Sector Steering
60	873 97 10-00	Nut Flange Lock 5/8-11
61	588 79 44-02	Draglink, LH
62	588 79 45-02	Draglink, RH
63	817 00 05-12	Screw 5/16-18 x 3/4
64	532 19 98-49	Retainer Clip Spring Steering
66	871 02 07-48	Bolt Hex Fghd 7/16-14 x 3 Serr
67	532 19 47-37	Bushing PM Front Axle
68	873 90 07-00	Nut Lock Flange 7/16-14 Gr. 5
69	532 19 91-62	Washer 1.5 x .505 x .118
70	585 33 88-01	Bracket Deck Susp. Front
71	532 19 07-52	Shaft Exten. Strg.
72	532 42 89-82	Bolt Fin Hx. 5/16-18 x 4 w/Patch
75	580 68 37-01	Pinion
76	580 68 36-01	Screw Head Sock
122	532 44 49-62	Cap Gear

NOTE: All component dimensions given in U.S. inches
1 inch = 25.4 mm

TRACTOR - MODEL NO. LTH1738 (96043024800), PRODUCT NO. 960 43 02-48
MOWER DECK

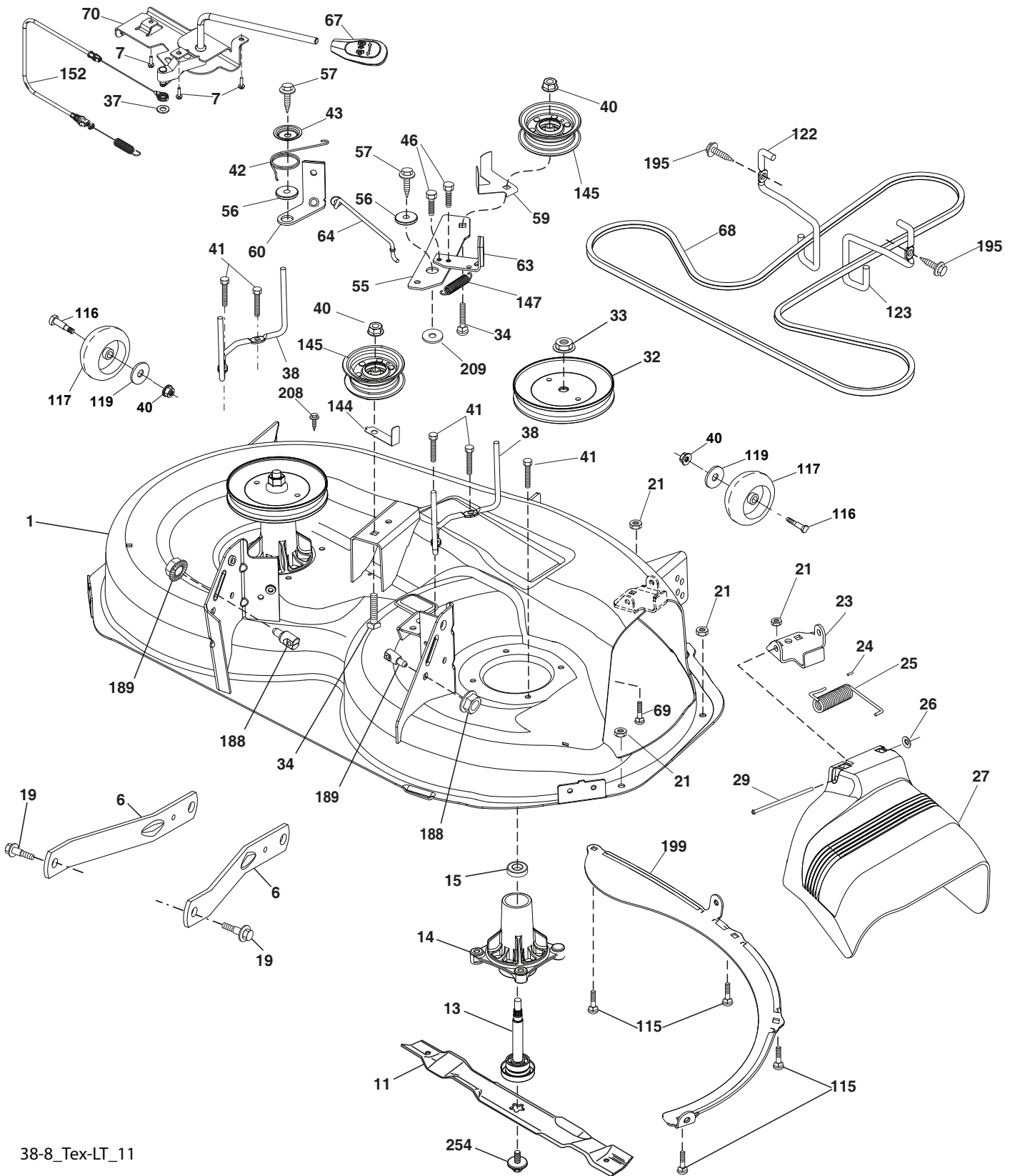

38-8_Tex-LT_11

**TRACTOR - MODEL NO. LTH1738 (96043024800), PRODUCT NO. 960 43 02-48
MOWER DECK**

KEY NO.	PART NO.	DESCRIPTION	KEY NO.	PART NO.	DESCRIPTION
1	587 77 18-14	Mower Housing	69	872 14 05-05	Bolt
6	532 19 51-86	Arm Suspension	70	532 40 12-46	Clutch Asm Manual
7	532 41 63-58	Screw #10 x 0.750 BOS Thread	115	872 11 05-05	Bolt Carr. 5/16-18 x 5/8
11	581 11 63-01	Blade 38"	116	532 12 48-42	Bolt, Shoulder
13	587 25 65-01	Shaft Assembly, Mandrel	117	589 52 74-01	Wheel, Gauge
14	532 18 72-81	Housing, Mandrel	119	819 12 14-14	Washer 3/8 x 7/8 x 14 Ga.
15	585 32 39-01	Bearing, Ball, Mandrel	122	532 19 72-58	Keeper Belt Engine LH
19	532 19 65-39	Bolt, Shoulder	123	532 19 72-59	Keeper Belt Engine RH
21	873 68 05-00	Nut, Crownlock 5/16-18 unc	144	532 19 34-14	Keeper Belt
23	532 19 25-57	Bracket, Deflector	145	532 19 31-97	Pulley Idler
24	532 10 53-04	Cap, Sleeve	147	532 40 18-72	Spring Return
25	532 19 70-26	Spring, Torsion, Deflector	152	532 43 51-11	Manual Clutch Cable
26	532 11 04-52	Nut, Push	188	532 19 51-61	Stud Fastener
27	532 19 39-68	Shield, Deflector	189	873 90 05-00	Nut Lock Hex Flange
29	532 13 14-91	Rod, Hinge	195	817 00 06-12	Screw 3/8-16 x 3/4
32	532 19 97-89	Pulley, Mandrel	199	532 40 00-95	Baffle Vortex
33	532 40 02-34	Nut, Toplock, Flanged	208	817 67 06-08	Screw Thdrol 3/8-16 x 1/2
34	872 11 06-12	Bolt Carr Sh. 3/8-16 x 1-1/2 Gr. 5	209	819 13 32-10	Washer 13/32 x 2 x 10
37	819 13 13-16	Washer	254	584 30 93-01	Screw Sems 7/16-20 x 1 Hex Head
38	532 19 95-41	Keeper Belt LH Mandrel	--	587 25 33-01	Mandrel Assembly (Includes housing (key# 14), shaft assembly (key# 13), and bearing (Key#15) only - pulley/washer and blade bolt/washers not included)
40	873 90 06-00	Nut, Lock Flg. 3/8-16 unc			
41	584 95 39-01	Bolt Hex Wshrhhd 313-18 x 1.19			
42	532 19 84-10	Spring Torsion Brake			
43	532 19 72-56	Spring Torsion Retainer			
46	532 13 77-29	Screw 1/4-20 x 5/8	--	592 93 89-01	Replacement Mower, Complete
55	532 19 72-49	Arm, Idler			
56	532 19 90-92	Spacer, Retainer			
57	817 00 06-16	Screw 3/8-16 x 1			
59	532 14 10-43	Guard, Tuv Idler			
60	532 19 94-71	Arm Brake Mower LH			
63	532 19 94-70	Arm Brake Mower RH			
64	532 19 99-18	Link Brake			
67	532 40 30-12	Handle Clutch Cable			
68	532 40 83-81	V-Belt			

NOTE: All component dimensions given in U.S. inches
1 inch = 25.4 mm

**TRACTOR - MODEL NO. LTH1738 (96043024800), PRODUCT NO. 960 43 02-48
MOWER LIFT**

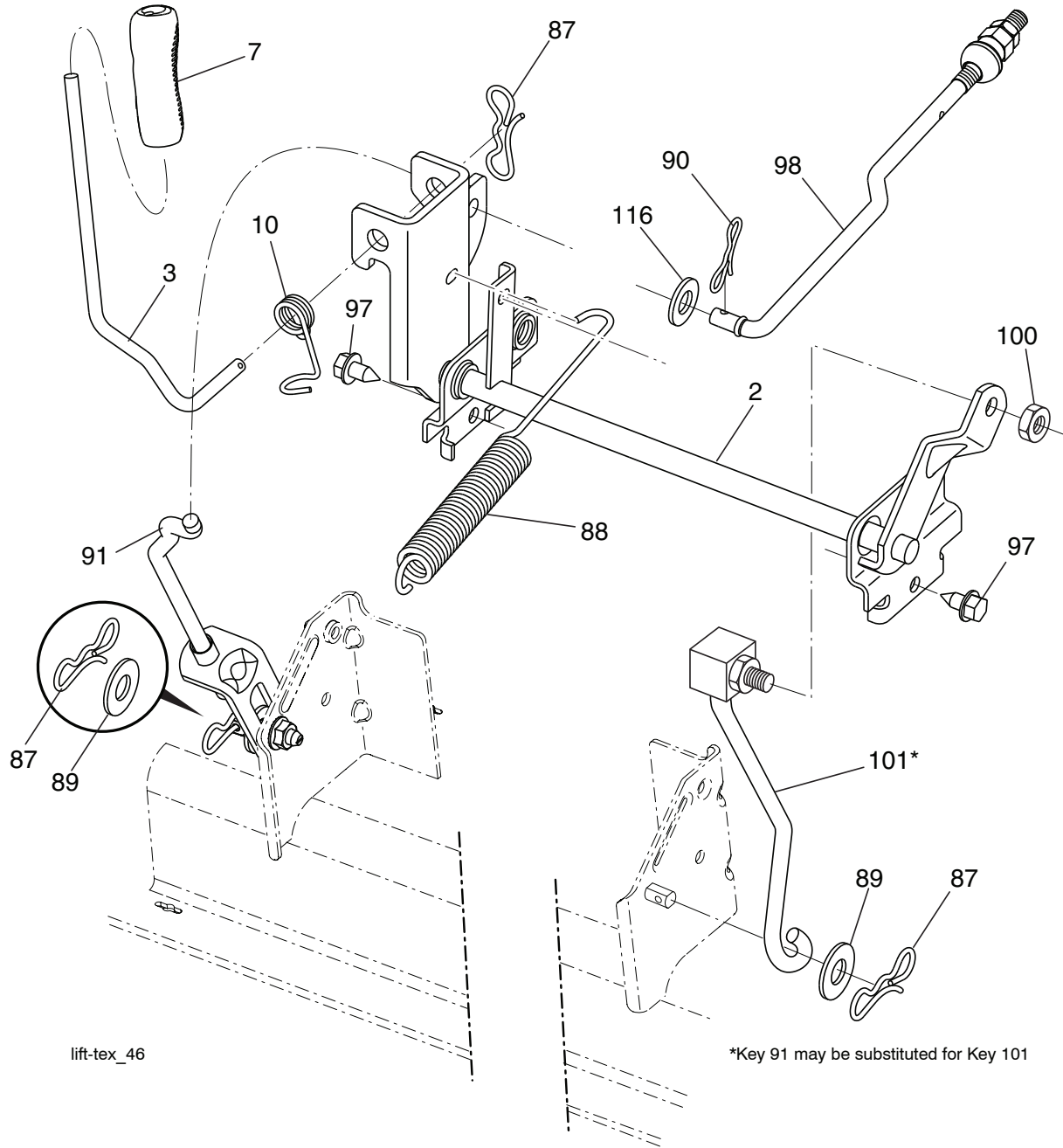

KEY NO.	PART NO.	DESCRIPTION
2	532 42 20-27	Shaft Asm., Lift
3	532 19 52-31	Lever Asm., Lift RH
7	580 96 23-01	Grip, Lever
10	532 19 63-14	Spring Torsion
87	532 19 42-09	Pin Cotter 7/16 Bow Tie Lock
88	532 41 07-10	Spring
89	819 19 19-12	Washer Clear Zinc
90	532 19 42-08	Pin Cotter 5/16 Bow Tie Lock
91	532 19 51-81	Link Asm Lift LH Rear

KEY NO.	PART NO.	DESCRIPTION
97	817 00 06-12	Screw Hex Wsh. THDR 3/8-16 x 3/4
98	532 19 52-70	Link Lift Susp. Front Mower
100	873 93 06-00	Nut Centerlock 3/8-16 unc
101	532 40 70-03	Link Asm. Fixed
116	819 15 15-16	Washer 15/32 x 15/16 x 16 Ga.

NOTE: All component dimensions given in U.S. inches
1 inch = 25.4 mm

TRACTOR - MODEL NO. LTH1738 (96043024800), PRODUCT NO. 960 43 02-48 SEAT ASSEMBLY

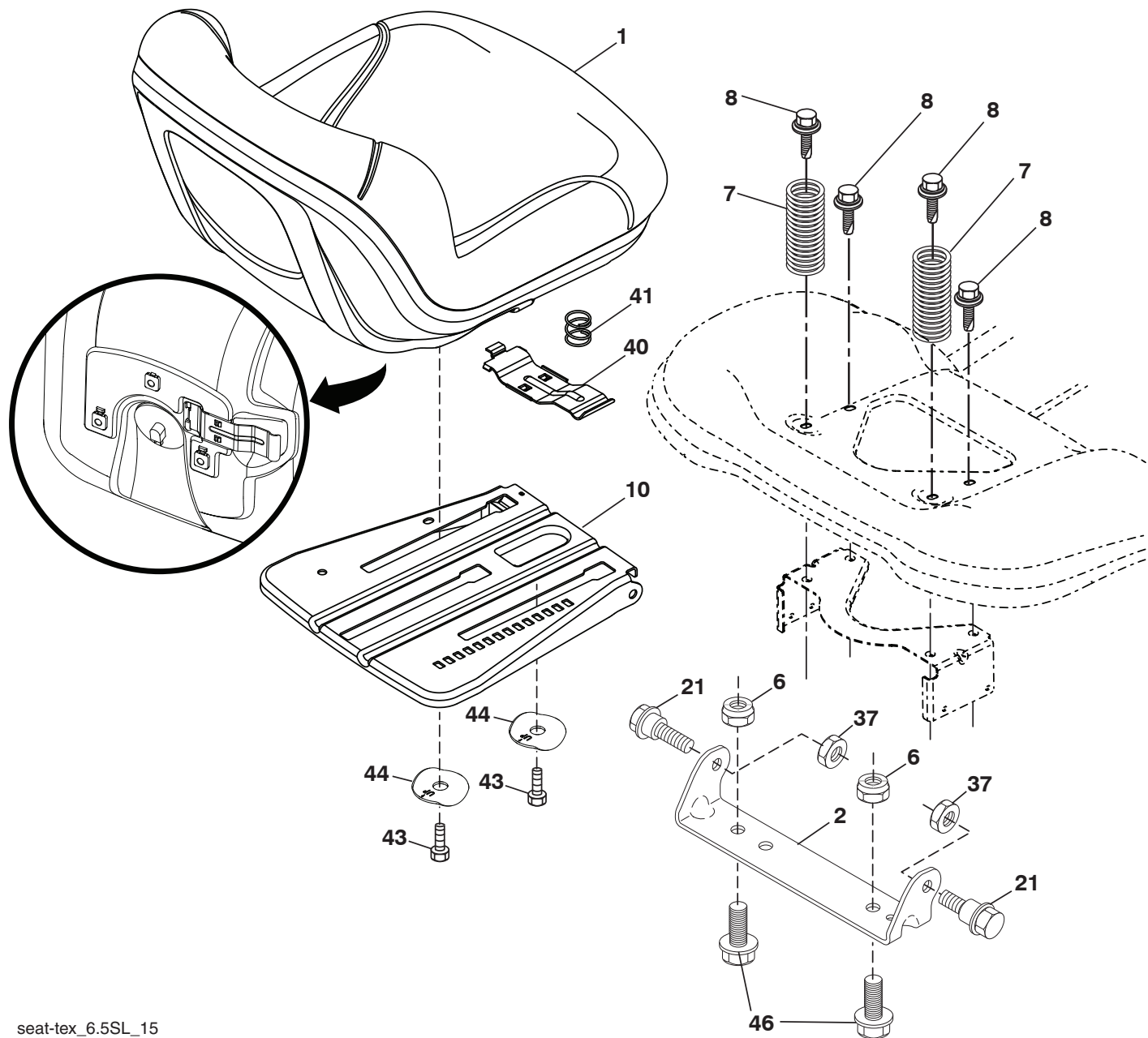

seat-tex_6.5SL_15

KEY NO.	PART NO.	DESCRIPTION
1	532 43 98-19	Seat
2	532 18 01-66	Bracket Pivot Fender
6	873 80 06-00	Nut, Lock w/Ins. 3/8-16 unc
7	589 48 35-01	Spring, Seat Cprsn
8	532 17 18-77	Bolt 5/16-18 unc x 3/4 w/Sems
10	587 23 20-02	Pan, Seat
21	587 90 78-01	Bolt, Shoulder 5/16-18 x 5/8
37	873 80 05-00	Nut, Lock 5/16-18 unc

KEY NO.	PART NO.	DESCRIPTION
40	532 19 76-61	Handle Slide Seat
41	532 19 82-00	Spring Latch Seat
43	874 76 06-12	Bolt Fin Hex 3/8-16 unc x 3/4
44	501 05 18-01	Washer Winged 3/8 ID 1.5 OD
46	588 09 04-01	Bolt 3/8-16 x 1: 1.25 OD Wshr.

NOTE: All component dimensions given in U.S. inches
1 inch = 25.4 mm

**TRACTOR - MODEL NO. LTH1738 (96043024800), PRODUCT NO. 960 43 02-48
DECALS**

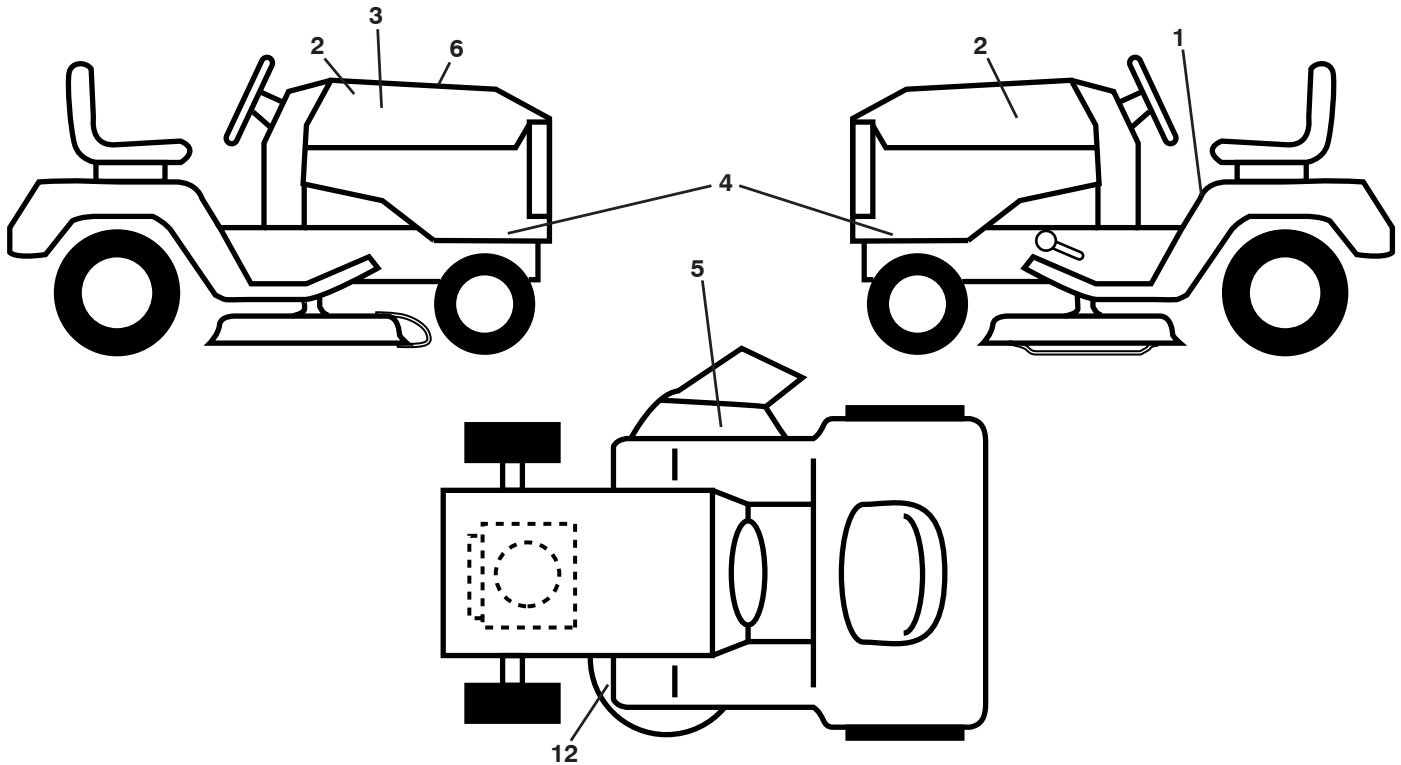

KEY NO.	PART NO.	DESCRIPTION
1	581 57 89-01	Decal, Fender Warn./Instructions
2	501 13 14-01	Decal, Husq
3	592 87 70-01	Decal, Replacement
4	592 90 67-01	Decal, Side Panel
5	584 90 46-01	Decal, Deflect. Warning
6	532 42 38-29	Decal, Warning
12	581 58 00-03	Decal, Mower V-Belt Schematic
--	581 72 48-01	Decal, Bypass
--	532 43 96-81	Pad, Footrest, LH

KEY NO.	PART NO.	DESCRIPTION
--	532 43 99-66	Pad, Footrest, RH
--	115 93 64-49	Manual, Operator's (English/Spanish)
--	115 93 65-49	Manual, Parts (English/Spanish)
--	587 71 00-26	Manual, Quick Start Guide (English/Spanish)

WHEELS AND TIRES

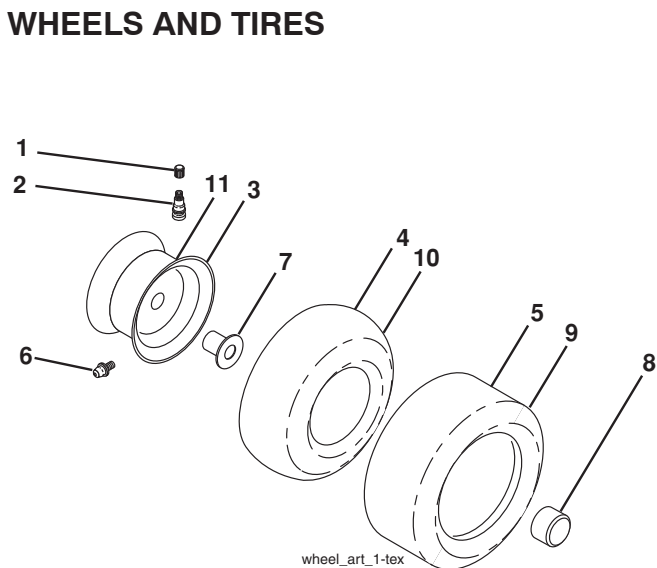

KEY PART NO.	PART NO.	DESCRIPTION
1	532 05 91-92	Cap Valve Tire
2	532 06 51-39	Stem Valve
3	532 13 83-36	Rim Asm 6" Front
4	532 05 99-04	Tube Front (Service Item Only)
5	532 10 62-22	Tire Front 15 x 6-6
6	532 12 49-57	Fitting Grease (Front Wheel Only)
7	532 12 49-59	Bearing Flange (Front Wheel Only)
8	532 17 50-39	Cap Axle Blk 1 50 x 1 00
9	532 13 84-68	Tire Rear 20 x 8-8
10	532 12 49-26	Tube Rear (Service Item Only)
11	532 13 83-37	Rim Asm 8" Rear
--	532 14 43-34	Sealant, Tire (10 oz. Tube)

NOTE: All component dimensions given in U.S. inches
1 inch = 25.4 mm

TRACTOR - MODELO NO. LTH1738 (96043024800), PRODUCTO NO. 960 43 02-48 DIAGRAMA

SCH11-s

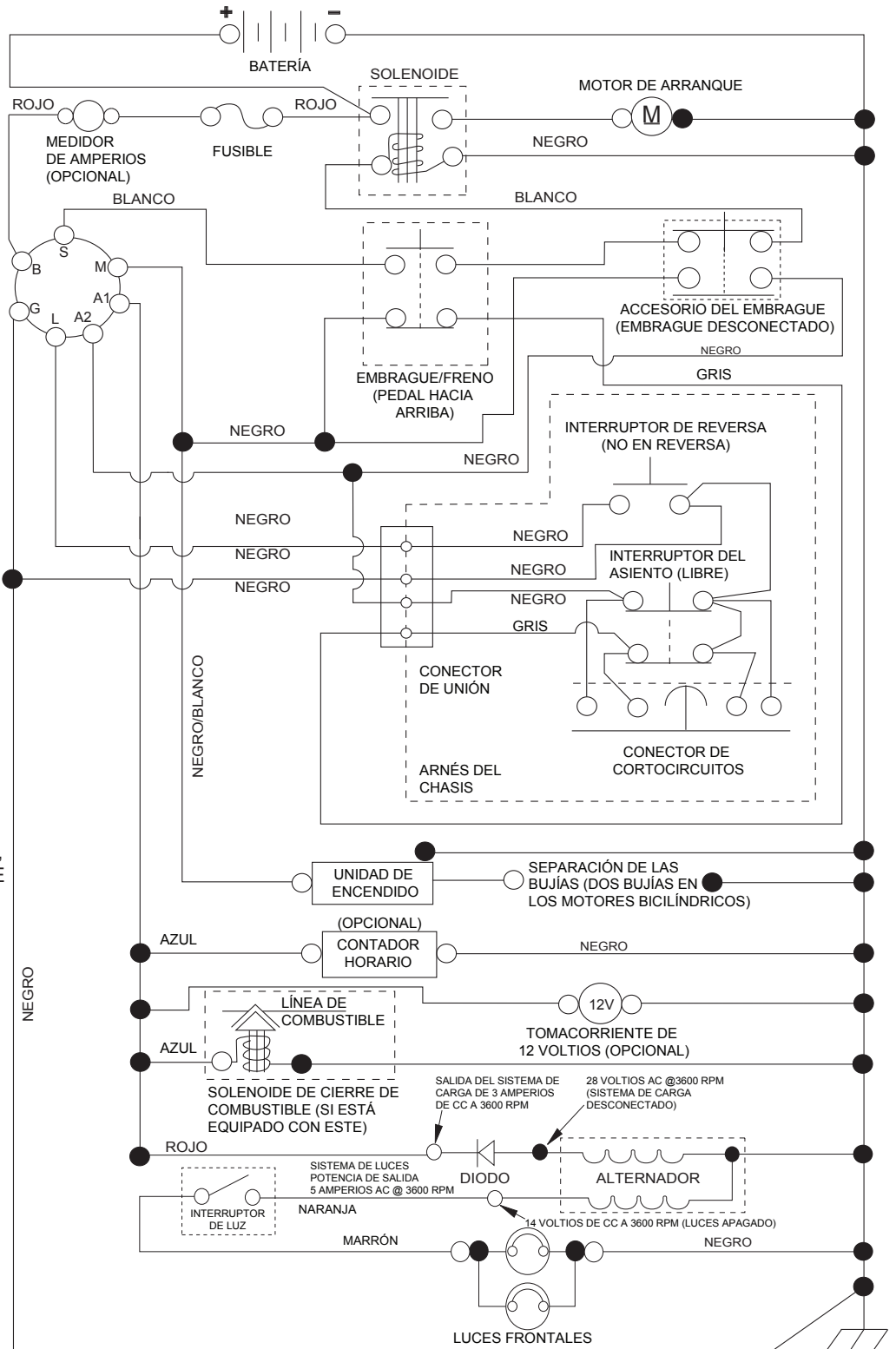

NOTAS:
QUE SU TRACTOR ES EQUIPADO CON UN SISTEMA ESPECIAL DE ALTERNADOR. LAS LUCES NO SON CONECTADAS A LA BATERIA, PERO TIENEN SU PROPIA FUENTE ELECTRICA. A CAUSA DE ESTO, EL BRILLO DE LAS LUCES CAMBIARA CON LA VELOCIDAD DE MOTOR. EN LENTO, LAS LUCES NO SON COMO BRILLANTES. CUANDO EL MOTOR ES ACELERADO, LA LUZ CONSEGUIRÁ MÁS BRILLANTE.

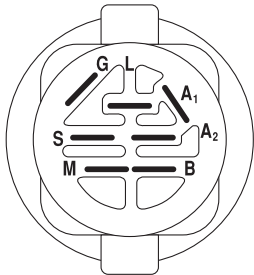

INTERRUPTOR DE ENCENDIDO

POSICIÓN	CIRCUITO «MARCA»
APAGADO	M+G+A1
PONER EN FUNCIONAMIENTO/ANULAR	B+A1
PONER EN FUNCIONAMIENTO	B+A1 L+A2
ARRANCAR	B + S + A1

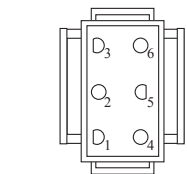

CONEXIÓN DEL ARNÉS DEL CHASIS (LATERAL QUE COINCIDA)

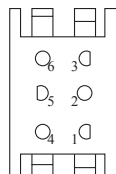

CONEXIÓN PARA EL ARNÉS DEL TABLERO (LATERAL QUE COINCIDA)

NOTA SOBRE LAS ABRAZADERAS DE AISLAMIENTO DEL CABLEADO: SI SE QUITAN LAS ABRAZADERAS DE AISLAMIENTO DEL CABLEADO PARA HACER EL MANTENIMIENTO DE LA UNIDAD, SE LAS DEBERÁ INSTALAR NUEVAMENTE PARA PROTEGER EL CABLEADO ADECUADAMENTE.

● CONEXIONES NO DESMONTABLES

○ CONEXIONES DESMONTABLES

TRACTOR - MODELO NO. LTH1738 (96043024800), PRODUCTO NO. 960 43 02-48
DIAGRAMA ELÉCTRICO

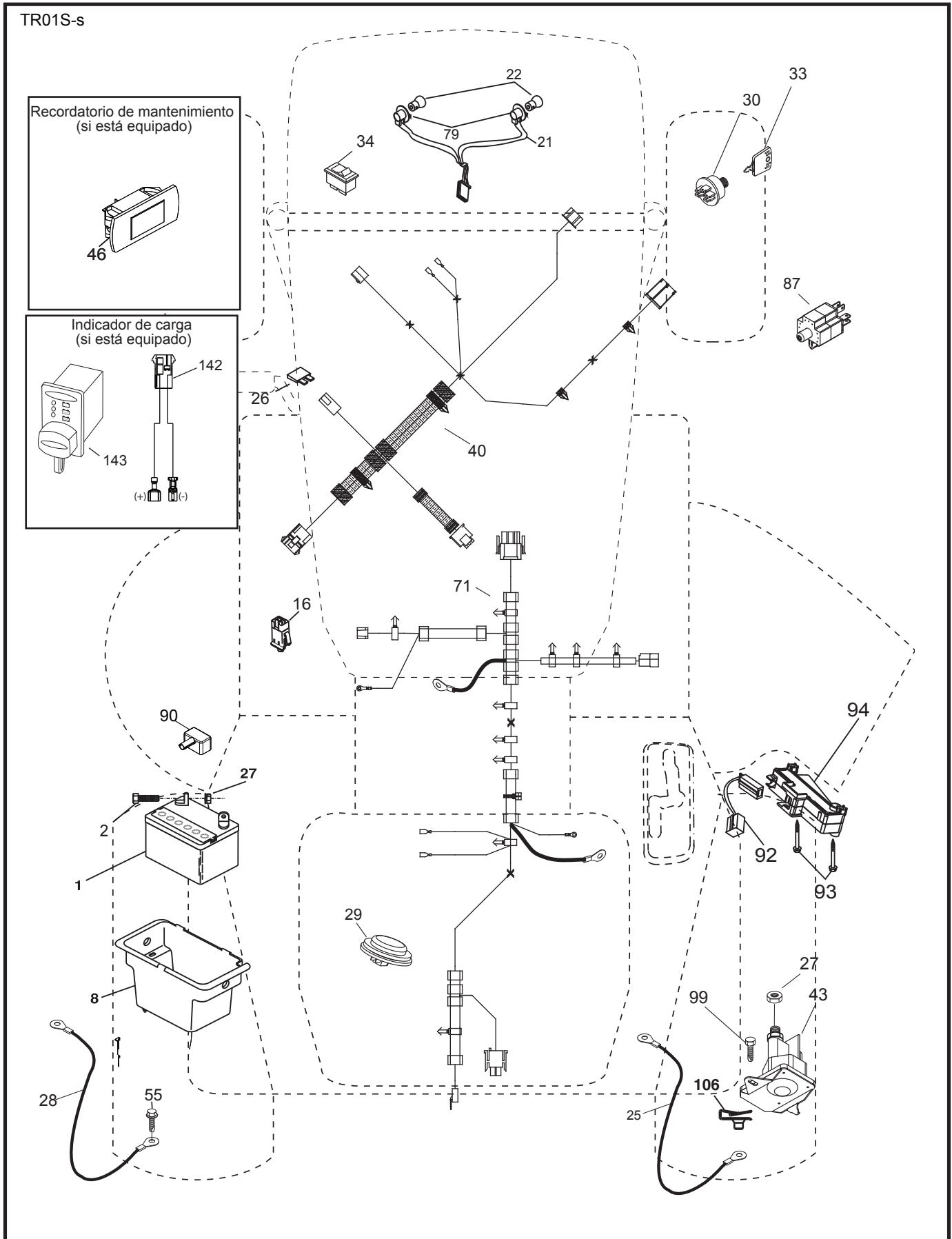

TRACTOR - MODELO NO. LTH1738 (96043024800), PRODUCTO NO. 960 43 02-48
DIAGRAMA ELÉCTRICO

CÓDIGO No.	PIEZA No.	DESCRIPCIÓN
1	532 16 34-65	Batería
2	874 76 04-12	Perno de cabeza hexagonal de 1/4-20 x 3/4
8	532 19 32-28	Caja de la batería
16	532 17 61-38	Interruptor corta corriente a presión
21	532 40 02-52	Cableado del enchufe para la luz
22	532 00 41-52	Bombilla de luz
25	581 49 80-01	Cable
26	532 17 51-58	Fusible
27	873 51 04-00	Tuerca hexagonal de 1/4-20 unc
28	532 42 16-86	Cable a tierra
29	532 40 15-45	Interruptor del asiento
30	532 19 33-50	Interruptor de encendido
33	532 41 19-33	Llave/cadena
34	532 11 07-12	Interruptor de luz/de restauración
40	581 02 31-01	Cableado del tablero de encendido
43	582 04 28-01	Solenoides
55	817 06 05-12	Tornillo de 5/16-18 x 3/4
71	501 13 37-01	Cableado de encendido
79	532 17 52-42	Enchufe de cierre por torsión del ensamble de la bombilla
87	532 19 78-02	Interruptor
90	532 43 53-95	Tapa de los bornes de la batería
92	532 19 66-15	Cableado de encendido
93	532 19 25-40	Tornillo 10-14 x 2.0
94	532 19 18-34	Retroceso del módulo ROS
99	817 67 04-12	Tornillo
106	532 17 48-14	Tuerca

NOTA: Las dimensiones de todos los componentes están expresadas en pulgadas americanas. 1 pulgada = 25,4 mm

TRACTOR - MODELO NO. LTH1738 (96043024800), PRODUCTO NO. 960 43 02-48
CHASIS

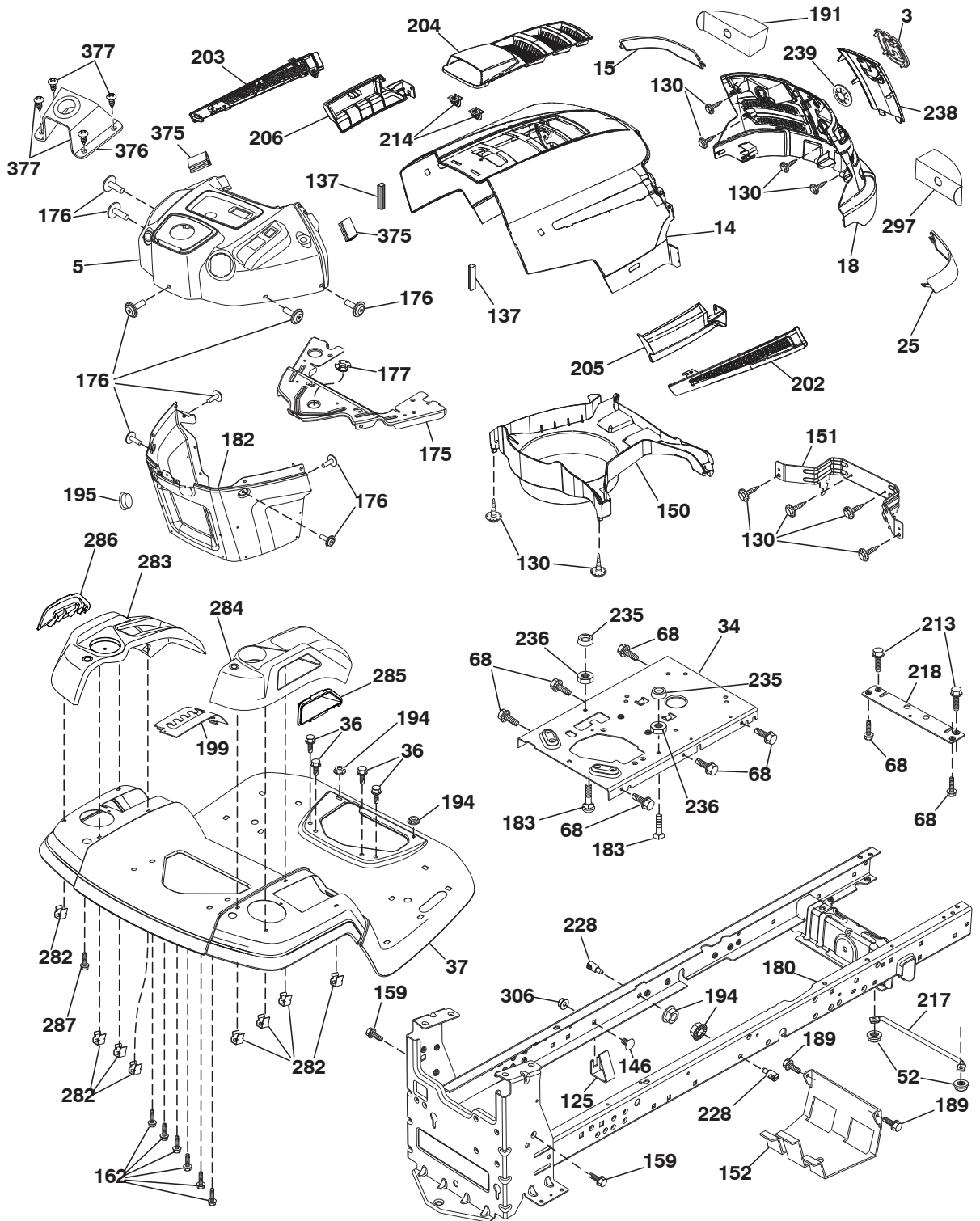

chassis-tex_TEX LT HUSQ_93

TRACTOR - MODELO NO. LTH1738 (96043024800), PRODUCTO NO. 960 43 02-48 CHASIS

CÓDIGO No.	PIEZA No.	DESCRIPCIÓN	CÓDIGO No.	PIEZA No.	DESCRIPCIÓN
3	581 05 63-01	Logo	202	532 44 13-42	Salida de Ventilación (LD)
5	501 86 11-01	Tablero	203	532 44 13-43	Salida de Ventilación (LI)
14	532 44 12-67	Capota	204	532 44 13-75	Salida de Ventilación superior
15	532 44 14-28	Lente izquierdo de la parrilla	205	532 44 13-44	Camisa de Capota (LD)
18	532 44 13-68	Parrilla	206	532 44 13-45	Camisa de Capota (LI)
25	532 44 14-27	Lente derecho de la parrilla	213	874 76 05-12	Perno 5/16-18 x 3/4
34	580 91 08-01	Chapa Motor	214	532 19 91-45	Cierre
36	817 06 05-12	Tornillo de 5/16-18 x 3/4	217	532 40 91-67	Varilla giratoria
37	532 44 12-66	Guardabarros	218	532 19 63-95	Tope
52	873 68 05-00	Tuerca de presión 5/16	228	532 19 51-61	Sujetador del travesaño
68	539 99 08-58	Tornillo de 5/16-18 x 1/2	235	532 40 61-29	Separador del guardabarros
125	581 68 48-01	Clip de la línea de combustible	236	873 93 05-00	Tuerca de presión 5/16-18 unc
130	532 41 63-58	Tornillo No. 10 x 0,75	238	532 44 13-74	Guarnición
137	532 40 75-90	Cubierta Tablero	239	532 40 48-83	Cierre
146	581 85 79-01	Perno 3/8-16 x 5/8	282	532 41 41-10	Cierre
150	532 40 66-62	Cubierta térmica del conducto	283	532 43 91-52	Console LI
151	532 40 78-07	Soporte	284	532 44 41-64	Console LD
152	532 19 95-35	Protector contra oscurecimiento	285	532 41 63-15	Insertar la consola LD
159	817 00 06-12	Tornillo 3/8-16 x 3/4	286	532 41 63-17	Insertar la consola LI
162	532 14 24-32	Tornillo	287	817 60 04-06	Tornillo 1/4-20 x 3/8
175	532 19 94-72	Travesaño	297	532 40 66-65	Inserte el derecho reflexivo (LI)
176	532 40 07-76	Tornillo de 10-24 x 5/8	306	873 90 06-00	Tuerca de presión de 3/8-16 unc
177	532 19 52-28	Buje de dirección	375	586 90 82-01	Cubierta Capota
180	532 19 54-57	Chasis	376	589 45 87-01	Conjunto de montaje
182	532 40 71-76	Tablero inferior	377	589 45 53-01	Tornillo de 10 x 1/2 ZN PL Phil Pan AB
183	874 52 05-20	Perno 5/16-18 x 1-1/4			
189	817 00 05-12	Tornillo			
191	532 41 65-01	Inserte el derecho reflexivo (LD)			
194	873 90 05-00	Tuerca de presión de 5/16-18			
195	532 43 99-76	Rociada del enchufe			
199	532 41 34-85	Placa de elevación de cubierta			

NOTA: Las dimensiones de todos los componentes están expresadas en pulgadas americanas. 1 pulgada = 25,4 mm

TRACTOR - MODELO NO. LTH1738 (96043024800), PRODUCTO NO. 960 43 02-48
TRANSMISIÓN

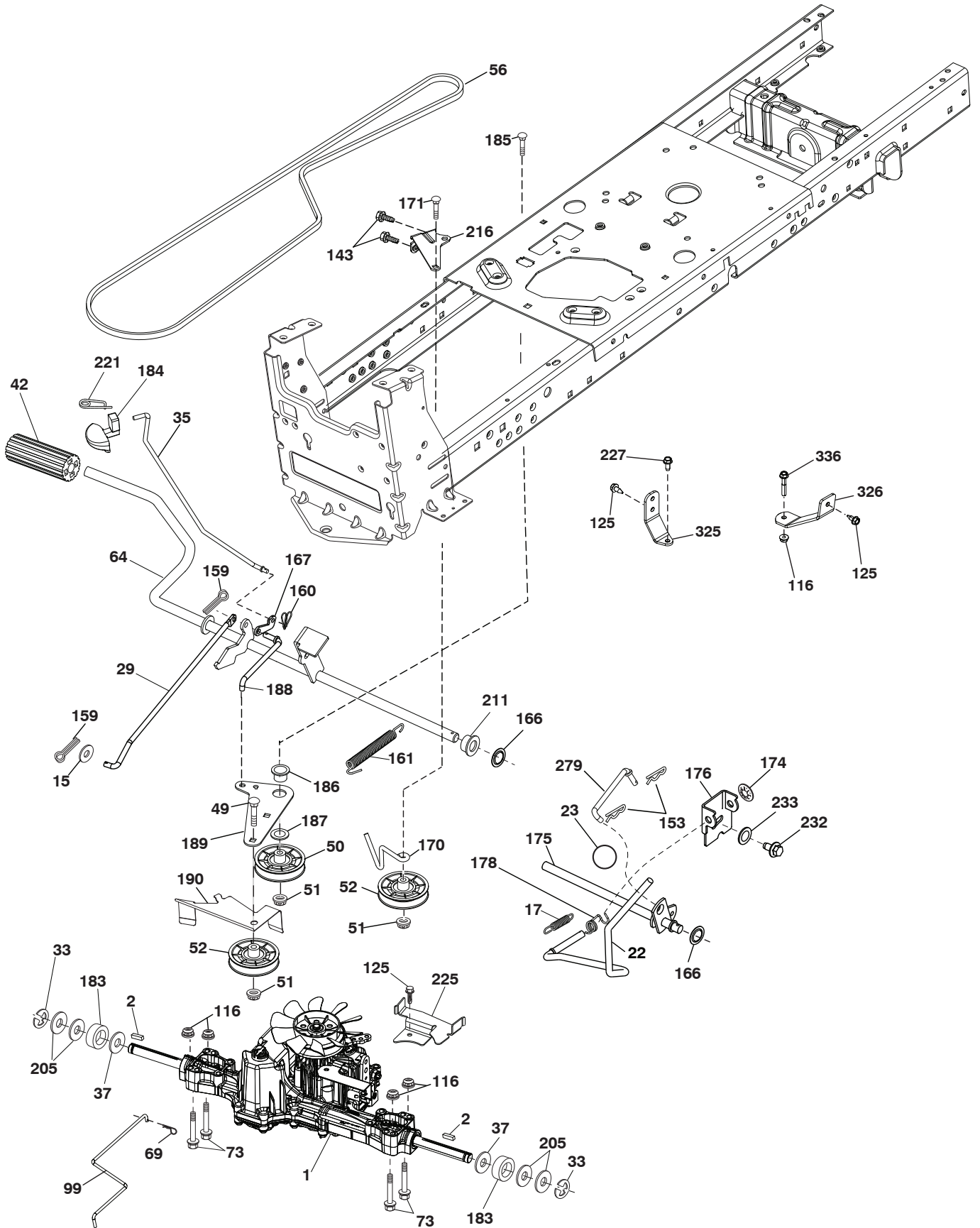

drive-tex_K46_fender_52

TRACTOR - MODELO NO. LTH1738 (96043024800), PRODUCTO NO. 960 43 02-48
TRANSMISIÓN

CÓDIGO NO.	NO.	PIEZA DESCRIPCIÓN	CÓDIGO NO.	NO.	PIEZA DESCRIPCIÓN
1	---	Transeje, Tufftorq K46BA (448348)(Haga el pedido de las piezas al fabricante del transeje.)	174	532 19 72-89	Tuerca
2	532 12 35-83	Llave	175	532 40 62-08	Ensamble del eje
15	819 13 13-16	Arandela 13/32 x 13/16 x calibre 16	176	532 19 62-14	Brazo
17	532 41 36-78	Resorte de freno	178	532 19 74-56	Resorte
22	532 19 76-60	Varilla	183	532 13 70-57	Separador
23	532 14 08-45	Perilla	184	532 41 14-84	Manija del freno de mano
29	532 40 38-06	Varilla del freno	185	872 11 06-22	Perno 3/8-16 x 2-3/4 Gr. 5
33	812 00 00-01	Aro "E"	186	532 19 43-21	Espaciador de retención
35	532 40 10-31	Varilla, freno de estacionamiento	187	819 13 32-10	Arandela
37	532 18 89-67	Arandela .793 x 1.637 x 060	188	582 21 70-01	Mecanismo de desplazamiento de la varilla de mando del embrague del largo
42	532 12 48-72	Cubierta del pedal	189	532 19 43-17	Palanca acodada del mecanismo de desplazamiento
49	872 11 06-14	Perno	190	532 19 43-18	Sujetador de la palanca acodada del mecanismo de desplazamiento
50	532 19 43-27	Polea loca plana	205	532 12 17-48	Arandela 25/32 x 1-5/8 x calibre 16
51	873 90 06-00	Tuerca de presión de 3/8-16	211	532 19 62-12	Buje
52	532 19 43-26	Polea "V"	216	532 19 61-31	Soporte tensor de polea
56	532 13 09-69	Correa trapezoidal de la transmisión	221	532 40 31-87	Abrazadera de retención del resorte de la manija
64	532 19 62-00	Ensamble del eje Control del pedal de freno	225	532 40 33-19	Sujetador de la correa
69	532 42 33-03	Horquilla .059 x 1.125	227	817 49 05-12	Tornillo 5/16-18 x 3/4
73	874 49 05-40	Perno 5/16-18 x 2 1/2 Gr. 5	232	874 78 07-16	Perno 7/16 x 1 Gr. 5
99	582 40 45-01	Varilla de desviación	233	532 40 52-96	Arandela
116	873 90 05-00	Tuerca 5/16-18	279	532 40 62-07	Acoplamiento
125	817 00 05-12	Tornillo 5/16-18 x 3/4	325	585 66 85-01	Soporte (LI)
143	539 99 08-88	Tornillo THDROL 5/16-18 x 1/2	326	585 67 08-01	Soporte (LD)
153	532 12 47-88	Retén del resorte	336	587 25 96-01	Perno 5/16-18 x 1-3/4
159	876 02 04-12	Pasador de chaveta de 1/8 x 3/4			
160	532 16 94-84	Abrazadera de retención			
161	532 10 57-09	Resorte de retorno del embrague			
166	532 42 91-64	Tuerca			
167	532 40 52-57	Pestillo del freno de mano			
170	532 19 43-22	Sujetador de la correa central			
171	872 11 06-16	Perno RD HD SQ NK 3/8-16 unc x 2			

NOTA: Las dimensiones de todos los componentes están expresadas en pulgadas americanas.
 1 pulgada = 25,4 mm

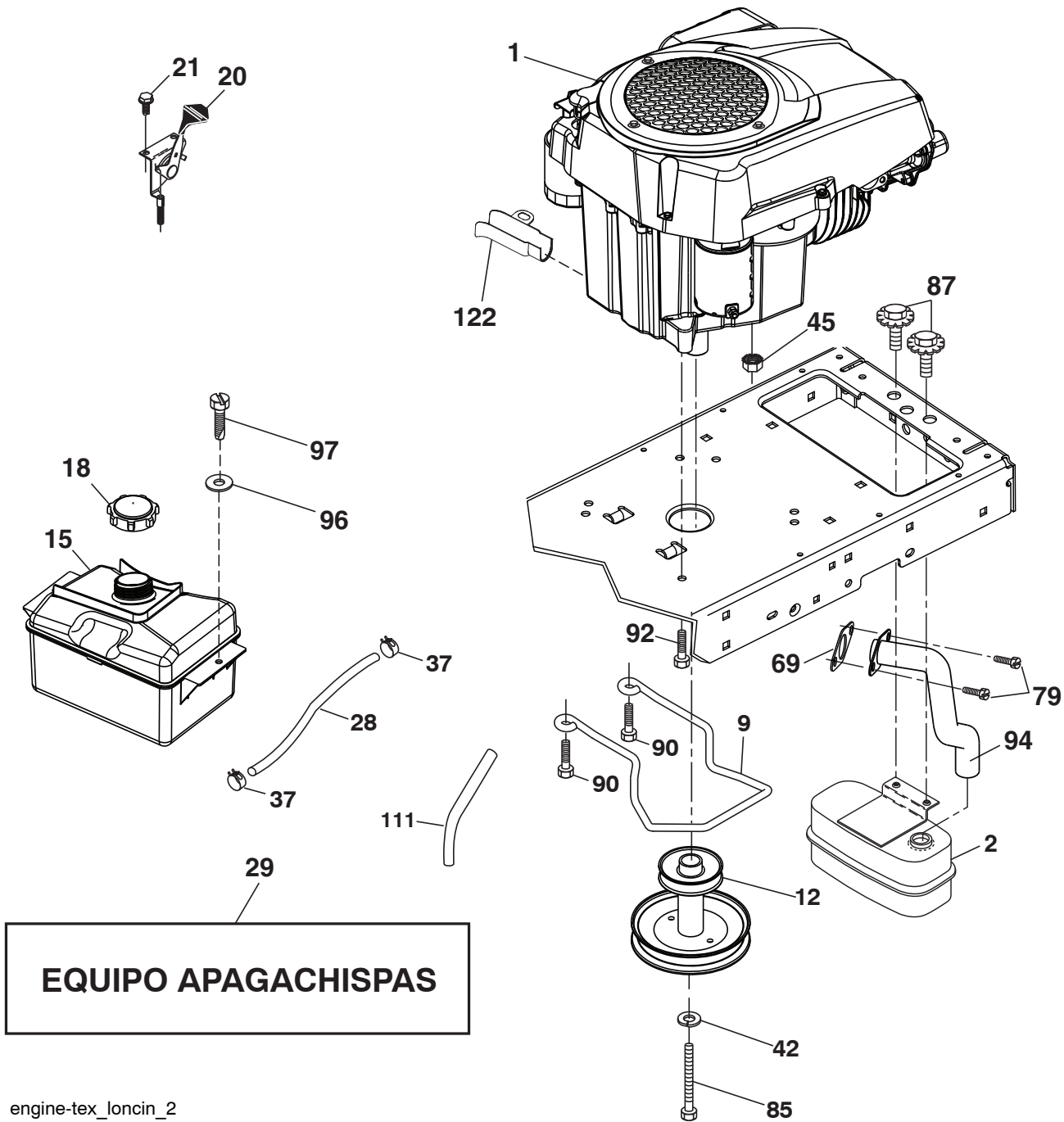

engine-tex_loncin_2

**TRACTOR - MODELO NO. LTH1738 (96043024800), PRODUCTO NO. 960 43 02-48
MOTOR**

CÓDIGO No.	PIEZA No.	DESCRIPCIÓN
1	— — — — —	Engine Husqvarna Model No. LC1P92F-1 (592822601)
2	590 64 53-01	Silenciador
9	501 83 26-01	Ensamble del sujetador de la correa del motor
12	586 47 85-01	Polea del motor
15	532 43 30-03	Tanque de Gasolina
18	581 17 61-01	Ensamble de la tapa
20	532 18 38-97	Control del regulador
21	532 41 63-58	Tornillo #10 x 0.750 BOS Thread
28	532 40 11-37	Línea de combustible
29	532 13 71-80	Equipo apagachispas
37	532 12 34-87	Abrazadera de la manguera
42	539 99 02-47	Arandela de presión de 7/16
45	873 51 04-00	Tuerca 1/4-20 unc
69	590 86 35-01	Junta
79	532 18 39-06	Tornillo de 5/16-18 x 1
85	501 60 65-01	Perno de 7/16-20 x 4 Gr. 5 1.5
87	532 17 18-77	Perno de 5/16-18 unc x 3/4
90	817 00 06-16	Tornillo de 3/8-16 x 1
92	817 12 06-16	Tornillo de 3/8-16 x 1
94	590 86 47-01	Tubo de descarga
96	819 09 14-16	Arandela de 9/32 x 7/8 x 16 Ga.
97	817 67 04-12	Tornillo de 1/4-20 x 3/4
111	532 41 41-19	Ligne de purge
122	532 42 19-22	Aceite de drenaje de extensión

NOTA: Las dimensiones de todos los componentes están expresadas en pulgadas americanas. 1 pulgada = 25,4 mm

TRACTOR - MODELO NO. LTH1738 (96043024800), PRODUCTO NO. 960 43 02-48
ENSAMBLE DE LA DIRECCIÓN

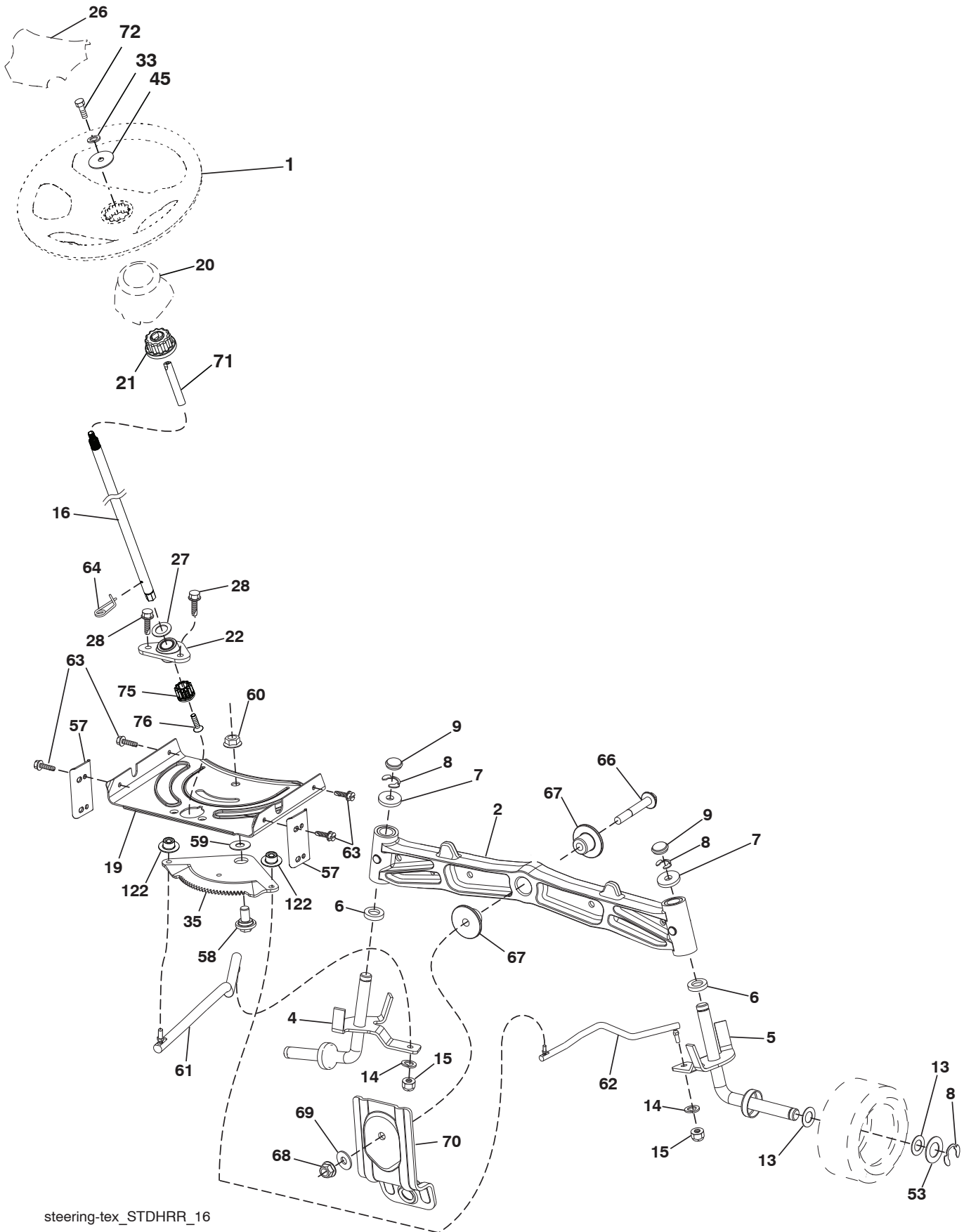

steering-tex_STDHRR_16

**TRACTOR - MODELO NO. LTH1738 (96043024800), PRODUCTO NO. 960 43 02-48
ENSAMBLE DE LA DIRECCIÓN**

CÓDIGO No.	PIEZA No.	DESCRIPCIÓN
1	532 43 97-40	Volante de dirección
2	532 19 59-68	Ensamble del eje delantero
4	532 40 30-87	Ensamble del husillo izquierdo
5	532 40 30-88	Ensamble del husillo derecho
6	532 12 49-31	Pista del rodamiento para reforzar el impulso
7	532 12 17-48	Arandela de 25/32 x 1-5/8 x 16 Ga.
8	812 00 00-29	Abrazadera del aro No. T5304-75
9	532 12 12-32	Tapa del husillo
13	532 12 17-49	Arandela de 25/32 x 1-1/4 calibre 16
14	539 99 01-18	Arandela de presión de 3/8
15	873 54 06-00	Tuerca de 3/8-24 unf
16	585 86 92-02	Eje de dirección
19	532 19 47-29	Placa de dirección
20	532 44 14-25	Accesorio de transición de la dirección
21	532 18 67-37	Adaptador del volante de dirección
22	585 02 98-02	Rodamiento
26	532 43 97-43	Inserto del volante de dirección
27	819 21 16-16	Arandela 21/32 x 1 x calibre 16
28	817 00 06-12	Tornillo de 3/8-16 x 3/4
33	539 99 01-87	Arandela de 5/16
35	532 19 47-32	Engranaje del sector de la placa
45	819 18 38-12	Arandela de 9/16 ID x 2-3/8 x calibre 12
53	532 18 89-67	Arandela de .793 x 1.637 x .060
57	532 40 74-65	Tope superior del soporte
58	532 19 47-47	Perno de tope del sector del pivote CFM
59	532 19 47-48	Arandela de empuje del sector de dirección
60	873 97 10-00	Tuerca de 5/8-11
61	588 79 44-02	Barra de acoplamiento izquierda
62	588 79 45-02	Barra de acoplamiento derecha
63	817 00 05-12	Tornillo de 5/16-18 x 3/4
64	532 19 98-49	Abrazadera de retención del resorte de la dirección
66	871 02 07-48	Perno de cabeza hexagonal con brida acanalada de 7/16-14 x 3
67	532 19 47-37	Buje PM del eje delantero
68	873 90 07-00	Tuerca de 7/16-14 grado 5
69	532 19 91-62	Arandela de 1,5 x 0,505 x 0,118
70	585 33 88-01	Soporte de la plataforma delantera
71	532 19 07-52	Extensión de eje
72	532 42 89-82	Perno. 5/16-18 x 4
75	580 68 37-01	Piñón
76	580 68 36-01	Tornillo
122	532 44 49-62	Tapas

NOTA: Las dimensiones de todos los componentes están expresadas en pulgadas americanas. 1 pulgada = 25,4 mm

TRACTOR - MODELO NO. LTH1738 (96043024800), PRODUCTO NO. 960 43 02-48
PLATAFORMA DE LA CORTADORA DE CÉSPED

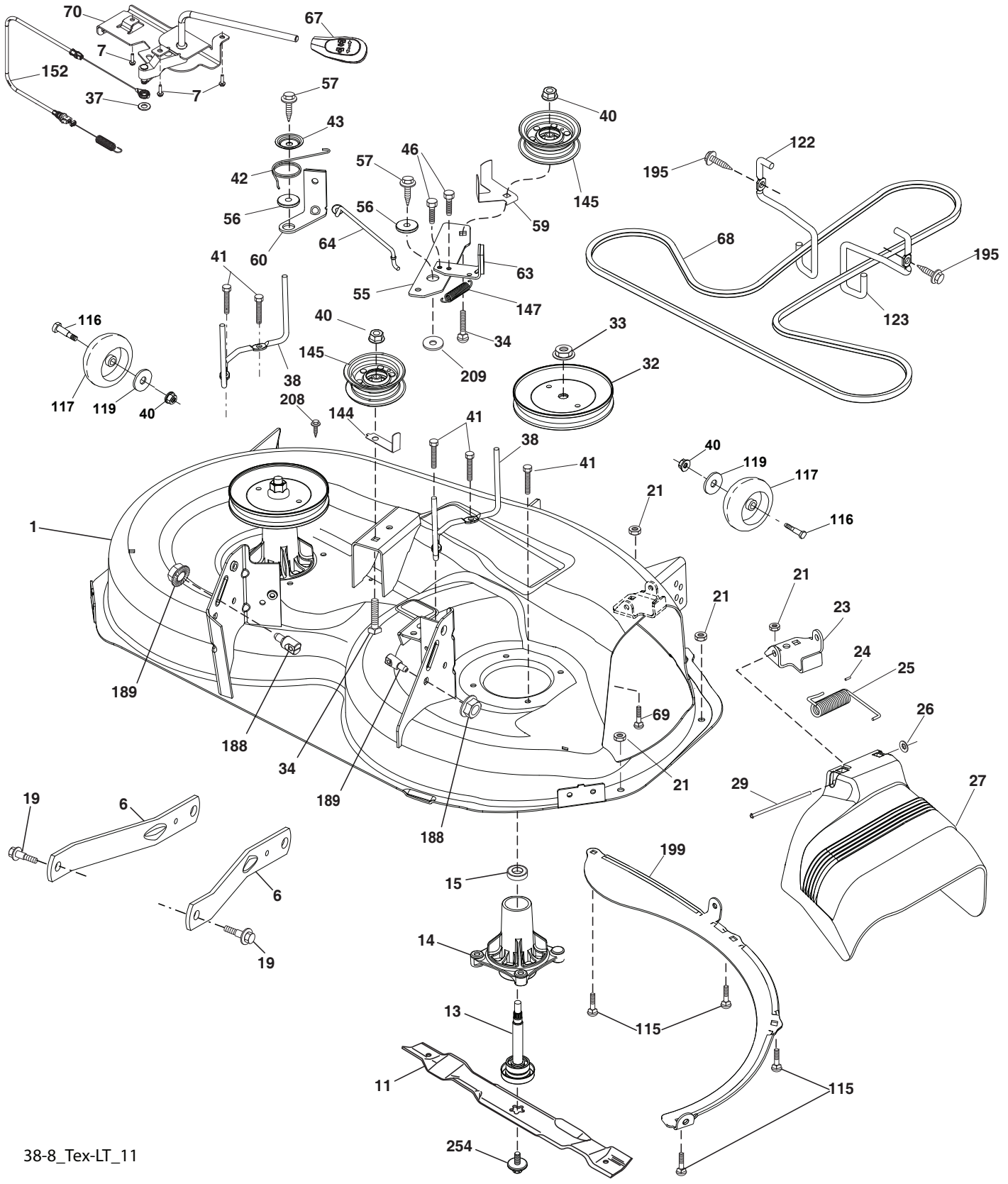

38-8_Tex-LT_11

**TRACTOR - MODELO NO. LTH1738 (96043024800), PRODUCTO NO. 960 43 02-48
PLATAFORMA DE LA CORTADORA DE CÉSPED**

CÓDIGO No.	PIEZA No.	DESCRIPCIÓN	CÓDIGO No.	PIEZA No.	DESCRIPCIÓN
1	587 77 18-14	Cubierta del cortacéspedes	68	532 40 83-81	Correa trapezoidal
6	532 19 51-86	Suspensión del brazo	69	872 14 05-05	Perno
7	532 41 63-58	Tornillode #10 x 0.750	70	532 40 12-46	Embrague Asmsembly Manua
11	581 11 63-01	Cuchilla de la cortadora de césped	115	872 11 05-05	Perno de 5/16-18 x 5/8
13	587 25 65-01	Ensamble del eje del mandril	116	532 12 48-42	Perno
14	532 18 72-81	Carcasa del mandril	117	589 52 74-01	Calibrador de la rueda
15	585 32 39-01	Rodamiento de bolas del mandril	119	819 12 14-14	Arandela de 3/8 x 7/8 x 14 Ga.
19	532 19 65-39	Perno	122	532 19 72-58	Motor de la correa del encargado (LI)
21	873 68 05-00	Tuerca	123	532 19 72-59	Motor de la correa del encargado (LD)
23	532 19 25-57	Soporte deflector	144	532 19 34-14	Motor de la correa
24	532 10 53-04	Tapa de la manga	145	532 19 31-97	Polea loca
25	532 19 70-26	Resorte de torsión del deflector	147	532 40 18-72	Crucero con retorno
26	532 11 04-52	Tuerca de presión	152	532 43 51-11	Cable
27	532 19 39-68	Protector del deflector	188	532 19 51-61	Sujetador del travesaño
29	532 13 14-91	Varilla de la bisagra	189	873 90 05-00	Tuerca de presión
32	532 19 97-89	Polea del mandril	195	817 00 06-12	Tornillo de 3/8-16 x 3/4
33	532 40 02-34	Tuerca de seguridad con brida	199	532 40 00-95	Deflector delantero
34	872 11 06-12	Tuerca de 3/8-16 x 1-1/2 Gr. 5	208	817 67 06-08	Tornillo 3/8-16 x 1/2
37	819 13 13-16	Arandela	209	819 13 32-10	Arandela de 13/32 x 2 x 10
38	532 19 95-41	Sujetador de la mandril (LI)	254	584 30 93-01	Tornillo 7/16-20 x 1
40	873 90 06-00	Tuerca de presión 3/8-16 unc	--	587 25 33-01	Ensamble del Mandril (solo incluye la carcasa (Código 14), el ensamble del (Código 13) eje y el rodamiento (Código 15); no incluye (Código 33) la polea/ arandela ni los pernos/arandelas de la cuchilla)
41	584 95 39-01	Perno 313-18 x 1.19			
42	532 19 84-10	Resorte de torsión del freno			
43	532 19 72-56	Resorte de torsión de retención			
46	532 13 77-29	Tornillo de 1/4-20 x 5/8			
55	532 19 72-49	Brazo de la polea			
56	532 19 90-92	Espaciador de retención	--	592 93 89-01	Reemplazo de la cortadora de césped, completa
57	817 00 06-16	Tornillo de 3/8-16 x 1			
59	532 14 10-43	Dispositivo de protección			
60	532 19 94-71	Brazo del freno de la cortadora de césped (LI)			
63	532 19 94-70	Brazo del freno de la cortadora de césped (LD)			
64	532 19 99-18	Acoplamiento del freno			
67	532 40 30-12	Cable de embrague de la manija			

NOTA: Las dimensiones de todos los componentes están expresadas en pulgadas americanas. 1 pulgada = 25,4 mm

TRACTOR - MODELO NO. LTH1738 (96043024800), PRODUCTO NO. 960 43 02-48
ELEVACIÓN DE LA CORTADORA DE CÉSPED

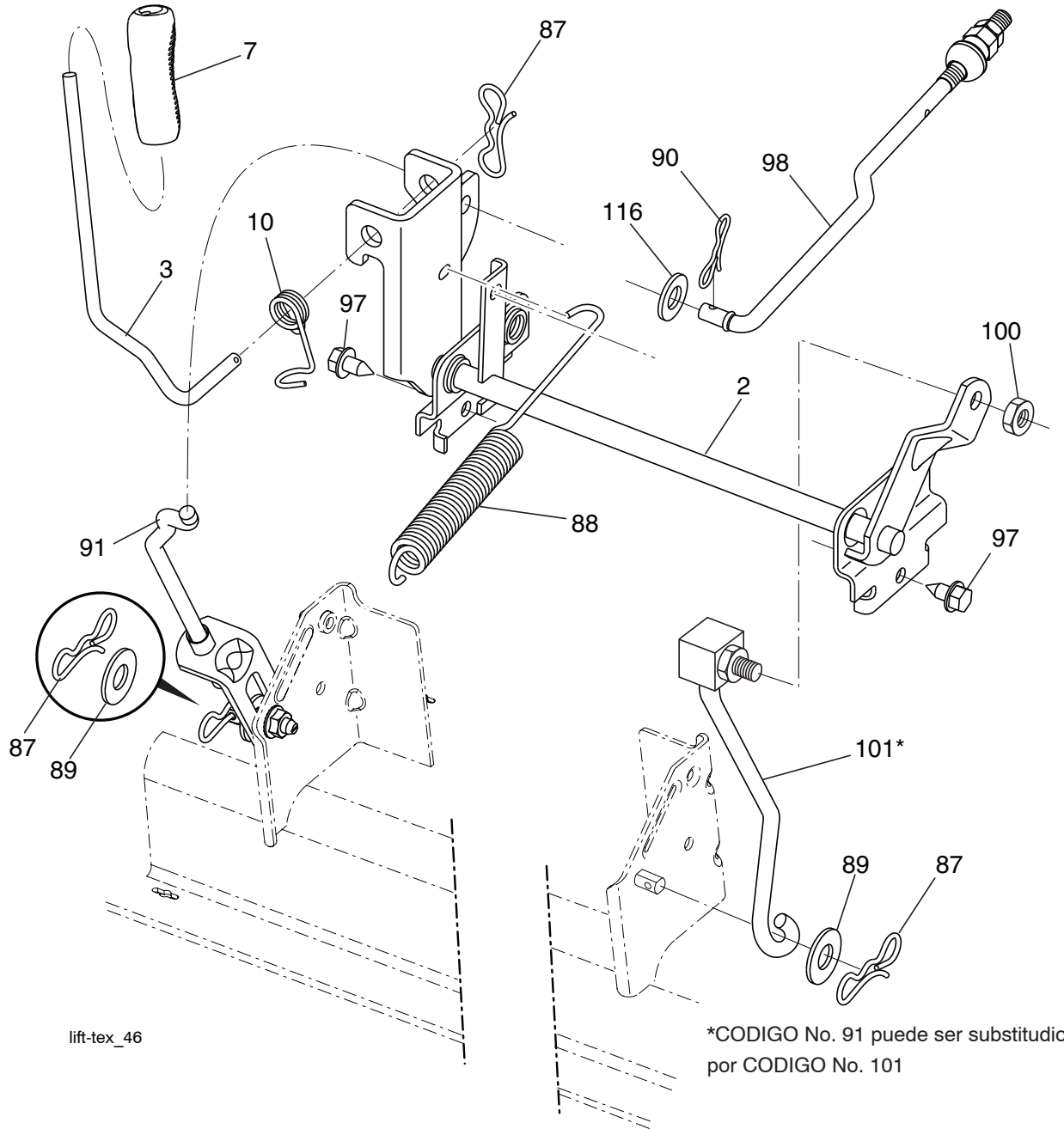

lift-tex_46

*CODIGO No. 91 puede ser substituido por CODIGO No. 101

CÓDIGO No.	PIEZA No.	DESCRIPCIÓN
2	532 42 20-27	Ensamble del eje de la elevación
3	532 19 52-31	Ensamble de la palanca de elevación derecha
7	580 96 23-01	Mango de la palanca
10	532 19 63-14	Resorte de torsión
87	532 19 42-09	Pasador de chaveta de 7/16 con bloqueo en forma de mariposa
88	532 41 07-10	Resorte
89	819 19 19-12	Arandela de zinc transparente
90	532 19 42-08	Pasador de chaveta de 5/16 con bloqueo en forma de mariposa
91	532 19 51-81	Ensamble del acoplamiento Elevación

CÓDIGO No.	PIEZA No.	DESCRIPCIÓN
97	817 00 06-12	Tornillo de 3/8-16 x 0,75
98	532 19 52-70	Acoplamiento frontal de la elevación de la cortadora de césped
100	873 93 06-00	Tuerca de presión central de 3/8-16 unc
101	532 40 70-03	Ensamble del acoplamiento Elevación fijo
116	819 15 15-16	Washer 15/32 x 15/16 x calibre 16

NOTA: Las dimensiones de todos los componentes están expresadas en pulgadas americanas. 1 pulgada = 25,4 mm

TRACTOR - MODELO NO. LTH1738 (96043024800), PRODUCTO NO. 960 43 02-48

ENSAMBLE DEL ASIENTO

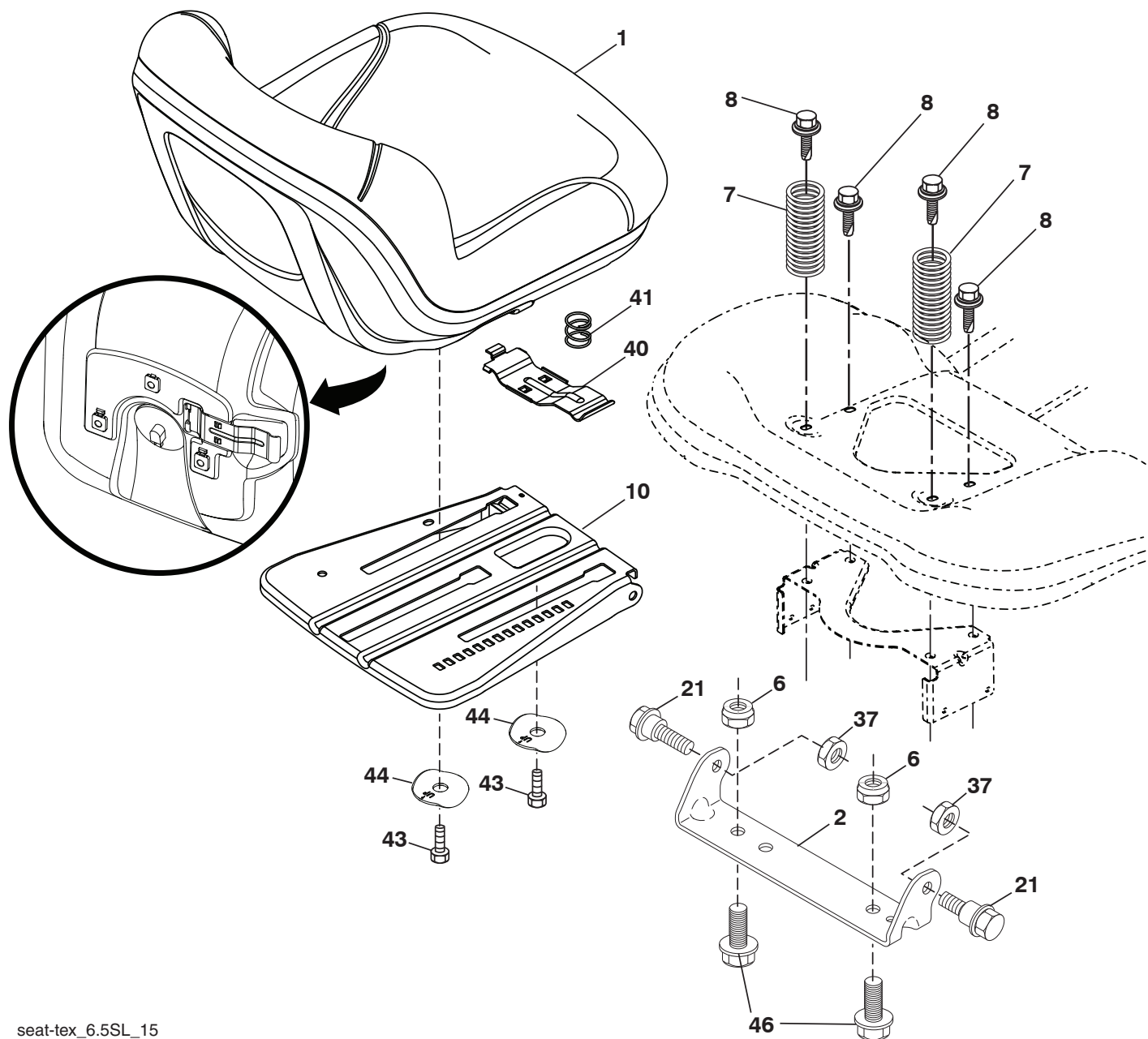

seat-tex_6.5SL_15

CÓDIGO No.	PIEZA No.	DESCRIPCIÓN
1	532 43 98-19	Asiento
2	532 18 01-66	Soporte pivotante del guardabarros
6	873 80 06-00	Tuerca de 3/8-16 unc
7	589 48 35-01	Resorte del asiento
8	532 17 18-77	Perno de 5/16" unc x 3/4"
10	587 23 20-02	Bandeja del asiento
21	587 90 78-01	Perno de tope de 5/16-18 x 5/8
37	873 80 05-00	Tuerca de presión de 5/16-18 unc
40	532 19 76-61	Manija para deslizar el asiento

CÓDIGO No.	PIEZA No.	DESCRIPCIÓN
41	532 19 76-61	Resorte para trabar el asiento
43	874 76 06-12	Perno de cabeza hexagonal con aleta de 3/8-16 unc x 3/4
44	501 05 18-01	Arandela 3/8 ID 1.5
46	588 09 04-01	Perno 3/8 ID 1.5 OD

NOTA: Las dimensiones de todos los componentes están expresadas en pulgadas americanas. 1 pulgada = 25,4 mm

**TRACTOR - MODELO NO. LTH1738 (96043024800), PRODUCTO NO. 960 43 02-48
CALCOMANÍAS**

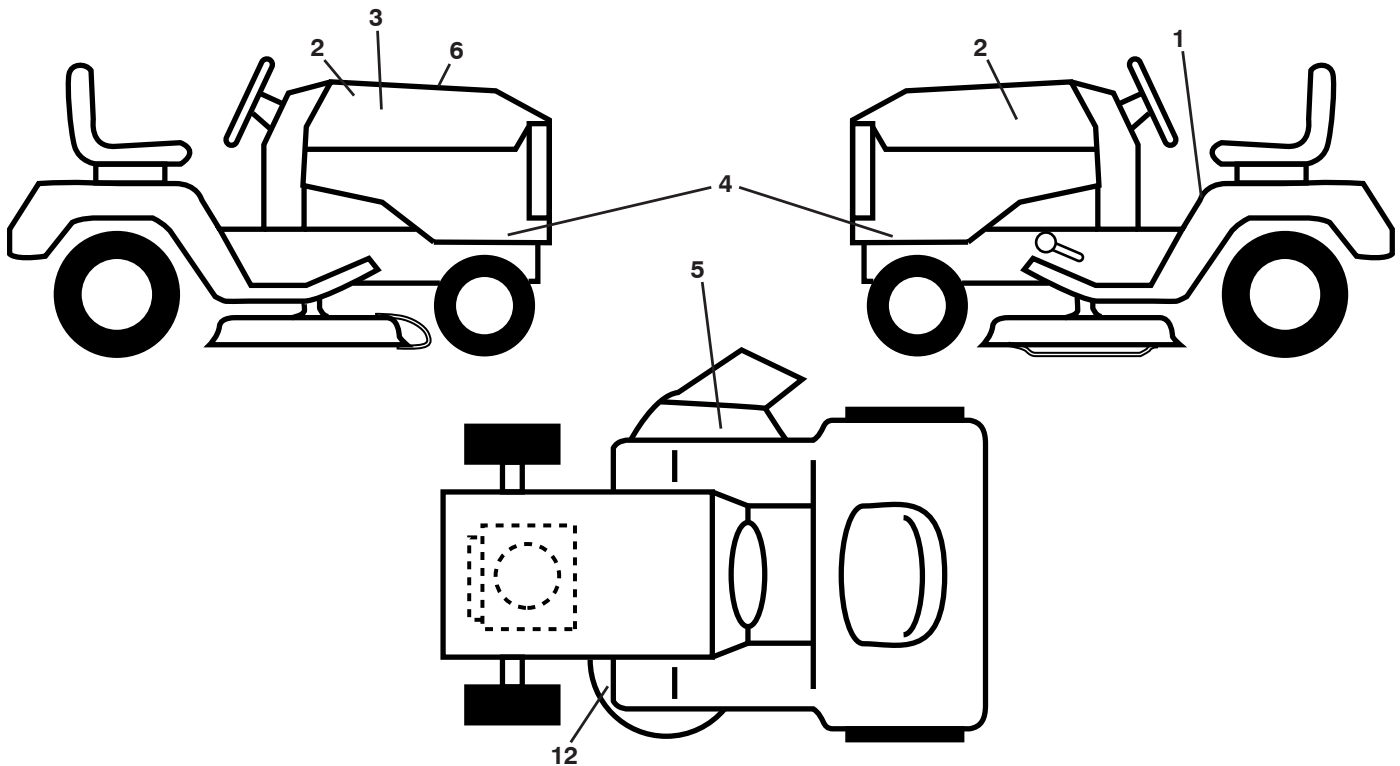

CÓDIGO No.	PIEZA No.	DESCRIPCIÓN
1	581 57 89-01	Calcomanía, la defensa advierte./ Instructions
2	501 13 14-01	Calcomanía, Husq
3	592 87 70-01	Calcomanía de reemplazo
4	592 90 67-01	Calcomanía para el panel lateral
5	584 90 46-01	Calcomanía, Advertencia
6	532 42 38-29	Calcomanía, Advertencia
12	581 58 00-03	Calcomanía, Correa "V"

CÓDIGO No.	PIEZA No.	DESCRIPCIÓN
--	581 72 48-01	Calcomanía, Puente
--	532 43 96-81	Reposapiés, (LI)
--	532 43 99-66	Reposapiés, (LD)
--	115 93 64-49	Manual del Operario (Inglés /Español)
--	115 93 65-49	Manual de Repuestos (Inglés/Español)
--	587 71 00-26	Manual QSG (Inglés /Español)

WHEELS AND TIRES

CÓDIGO No.	PIEZA No.	DESCRIPCIÓN
1	532 05 91-92	Tapa de la válvula del neumático
2	532 06 51-39	Vástago de la válvula
3	532 14 45-09	Ensamble de las llantas delanteras
4	532 05 99-04	Cámara delantera
5	532 10 62-22	Neumático delantero 15 x 6-6
6	532 12 49-57	Accesorio para engrasar (solo para la rueda delantera)
7	532 12 49-59	Rodamiento de la brida (solo para la rueda delantera)
8	532 17 50-39	Tapa del eje (solo para la rueda delantera)
9	532 13 84-68	Neumático trasero 20 x 8-8
10	532 00 71-54	Cámara trasera (Service Item Only)
11	532 40 17-82	Ensamble trasero de la llanta
--	532 14 43-34	Sellador para neumáticos (tubo de 10 onzas [283 gr])

NOTA: Las dimensiones de todos los componentes están expresadas en pulgadas americanas. 1 pulgada = 25,4 mm

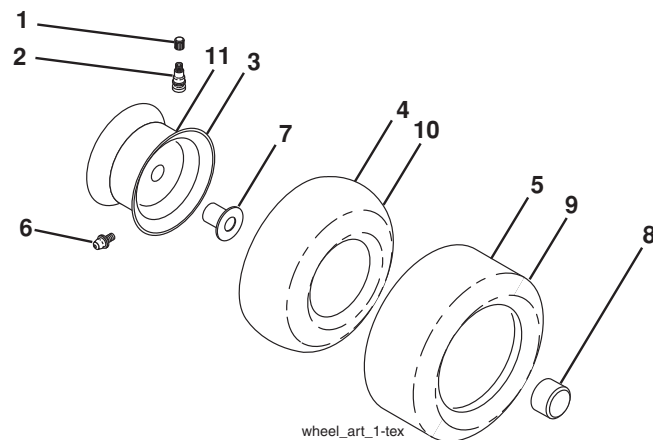

wheel_art_1-tex

NOTES/AVISO

**TRACTOR - MODEL NO. LTH1738 (96043024800), PRODUCT NO. 960 43 02-48
HUSQVARNA ENGINE (452 CC)**

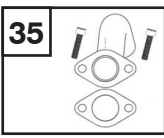
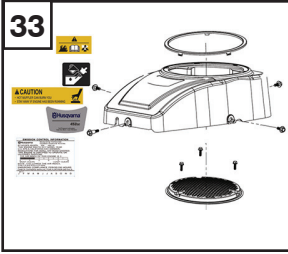
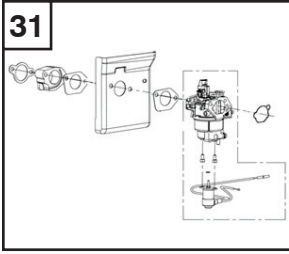
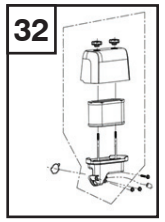
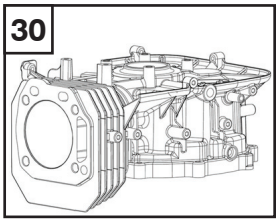
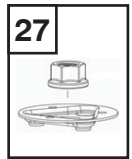
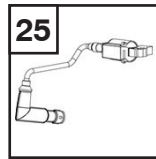
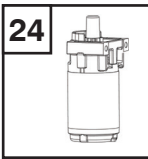
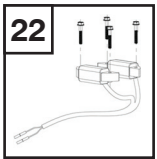
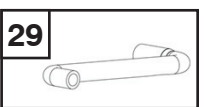
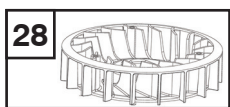
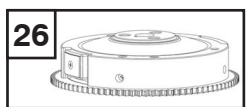
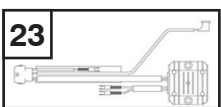
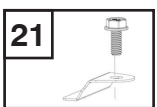
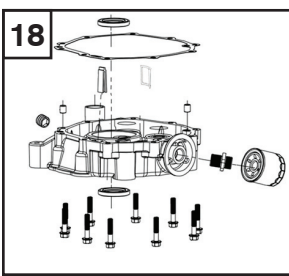
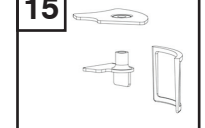
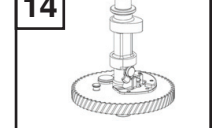
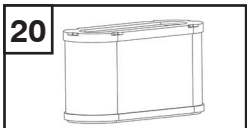
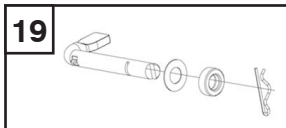
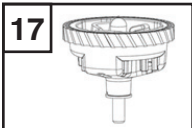
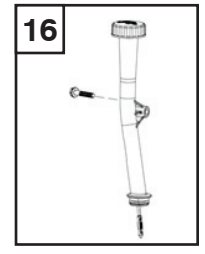
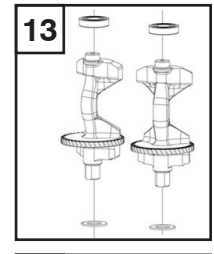
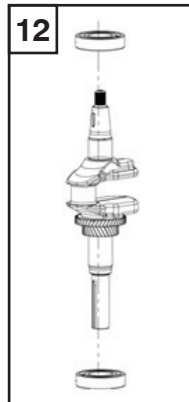
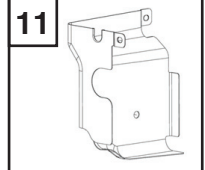
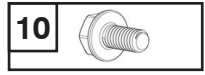
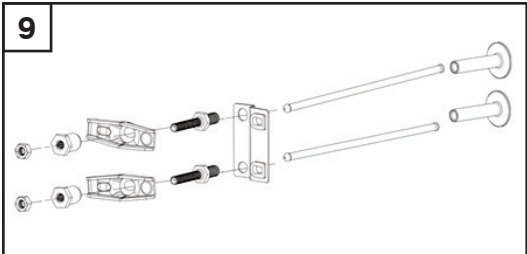
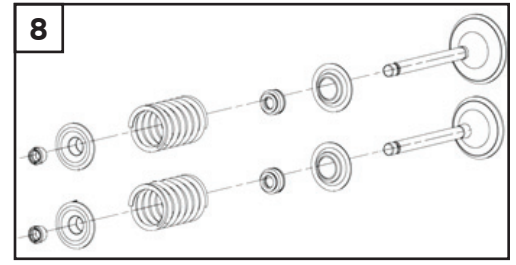
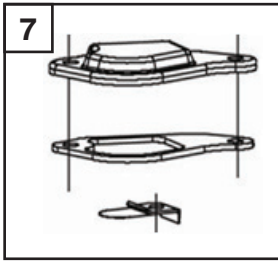
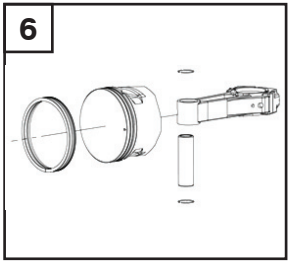
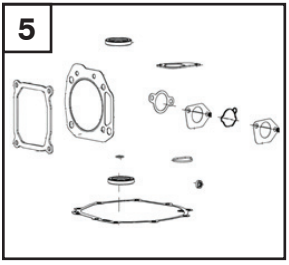
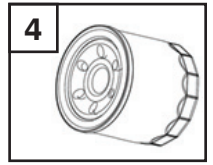
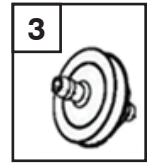
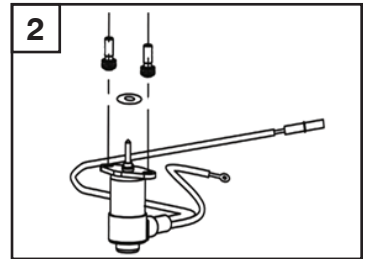
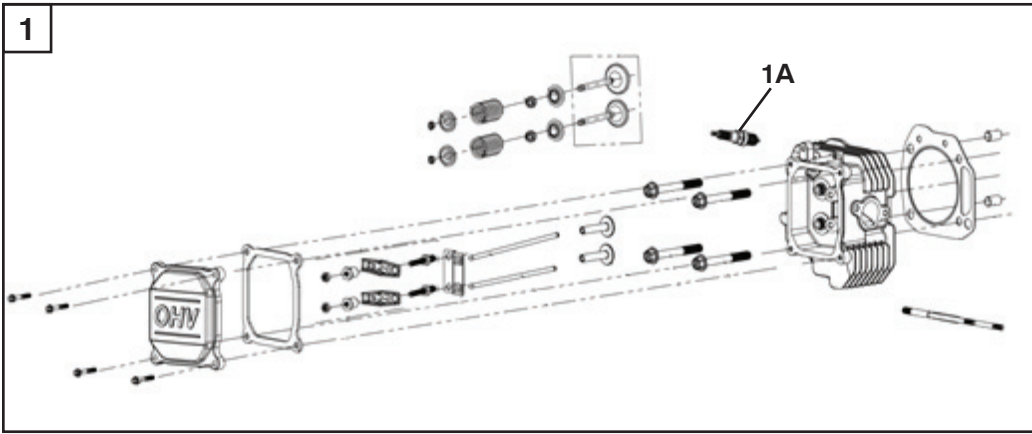

**TRACTOR - MODEL NO. LTH1738 (96043024800), PRODUCT NO. 960 43 02-48
HUSQVARNA ENGINE (452 CC)**

ITEM NO.	PART NO.	DESCRIPTION	QTY.
1	590904901	CYLINDER HEAD COMP KIT	1
1A	591165501	SPARK PLUG	1
2	590905101	SOLENOID KIT	1
3	591165801	FUEL FILTER	1
4	591165901	OIL FILTER	1
5	590905401	GASKET AND SEAL KIT	1
6	590905501	PISTON AND RING SET, PISTON KIT	1
7	590905601	COVER COMP BREATHER AND STRAINER FUEL KIT	1
8	590971701	VALVE KIT	1
9	590971801	ROCKER ARM KIT	1
10	590971901	HEXAGON BOLT WITH FLANGE	1
11	590972101	AIR DEFLECTOR	1
12	590972201	CRANKSHAFT KIT	1
13	590972301	BALANCING SHAFT KIT	1
14	590972401	CAMSHAFT ASSY	1
15	590972501	OIL STRAINER KIT	1
16	590972601	FILL TUBE KIT	1
17	590972701	GOVERNER GEAR KIT	1
18	590972801	CRANKCASE COVER KIT	1
19	590972901	SPEED REGULATING ARM KIT	1
20	590973101	AIR FILTER	1
21	590973501	PRESSING PLATE KIT	1
22	590973601	CHARGING ARMATURE KIT	1
23	590973801	VOLTAGE RECTIFIER	1
24	590974301	STARTER MOTOR KIT	1
25	590975801	IGNITION COIL ASSEMBLY	1
26	590978001	FLYWHEEL COMP	1
27	590992201	STARTING DISC KIT	1
28	590992301	IMPELLER	1
29	590965901	BREATHER TUBE	1
30	592951101	CRANKCASE BODY KIT	1
31	593098301	CARBURETOR KIT - US	1
32	593098501	AIR CLEANER KIT	1
33	593098601	START COVER KIT	1
34	593098801	THROTTLE LEVER KIT - US	1
35	592952001	EXHAUST PIPE KIT	1

**TRACTOR - MODELO NO. LTH1738 (96043024800), PRODUCTO NO. 960 43 02-48
HUSQVARNA MOTOR (452 CC)**

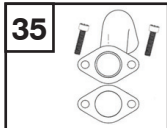
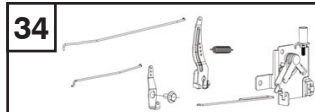
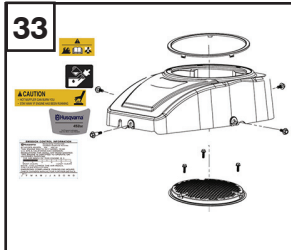
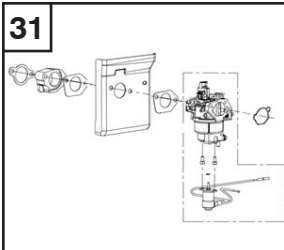
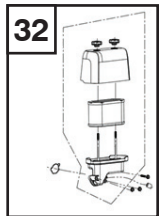
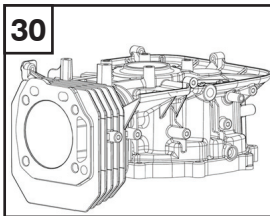
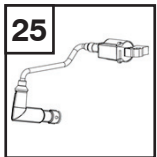
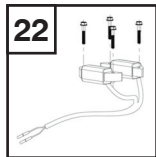
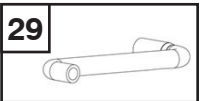
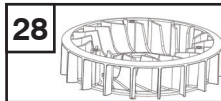
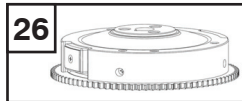
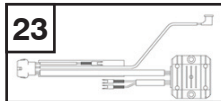
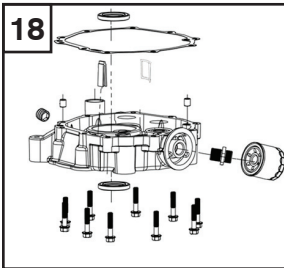
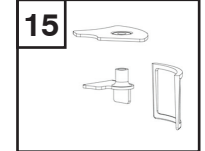
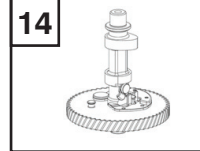
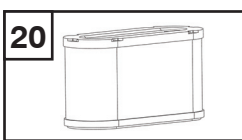
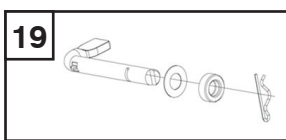
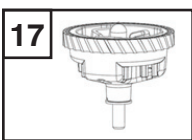
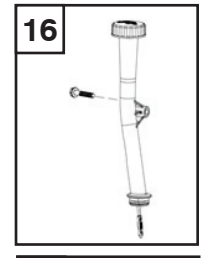
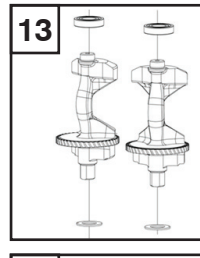
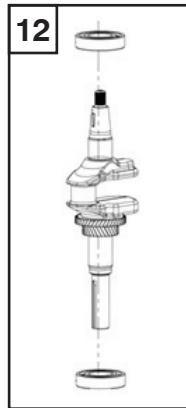
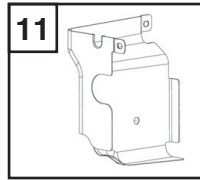
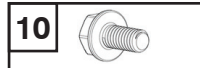
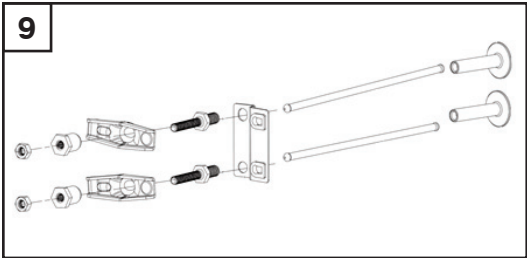
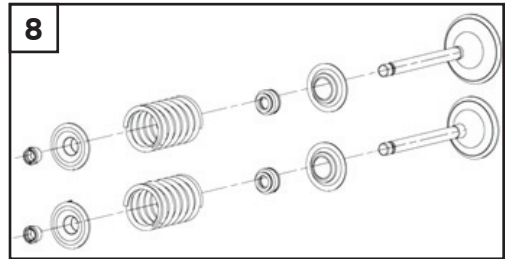
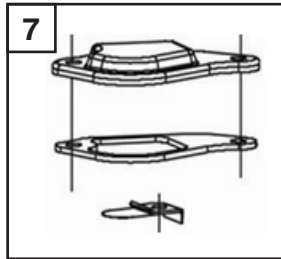
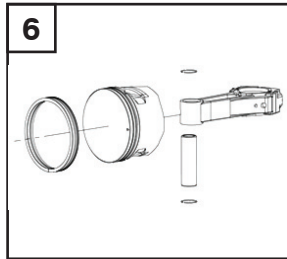
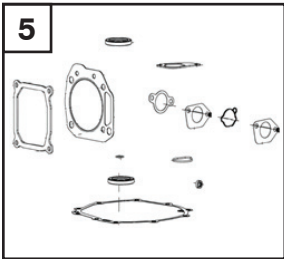
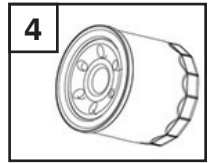
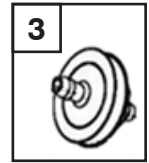
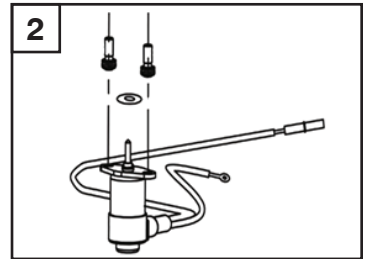
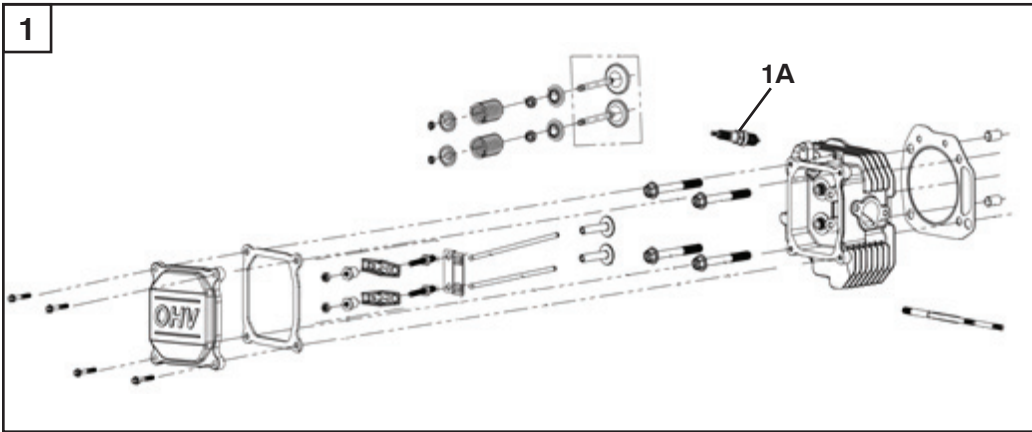

**TRACTOR - MODELO NO. LTH1738 (96043024800), PRODUCTO NO. 960 43 02-48
HUSQVARNA MOTOR (452 CC)**

CÓDIGO No.	PIEZA No.	DESCRIPCIÓN	CANT.
1	591166101	KIT COMPLETO DE LA CULATA	1
1A	591166001	BUJÍA	1
2	590901901	KIT DEL SOLENOIDE	1
3	590902001	KIT DEL CARBURADOR WITHOUT FUEL PUMP	1
--	593240101	KIT DEL CARBURADOR WITH FUEL PUMP	1
4	593230701	KIT DEL PURIFICADOR DEL AIRE	1
5	590902201	KIT DE LA JUNTA Y DEL SELLO	1
6	590903001	CONJUNTO DE ANILLOS Y PISTÓN, KIT DE PISTÓN	1
7	590903101	PROPULSOR	1
8	590903201	KIT DE LA VÁLVULA DE LENGÜETA	1
9	590903301	VÁLVULA, KIT DEL RESPIRADOR	1
10	592964601	KIT DEL VENTILADOR DE REFRIGERACIÓN CON CUBIERTA	1
11	593230901	KIT DE LA CUBIERTA DEL ARRANCADOR	1
12	591042401	VALVE KIT	1
13	591042501	CYLINDER HEAD KIT	1
14	591042701	AIR DEFLECTOR KIT	1
15	591042801	CRANKCASE BODY KIT	1
16	593231001	FILTRO DE AIRE	1
17	591043201	KIT DE LA CUBIERTA DEL CÁRTER	1
18	591043301	FILTRO DE ACEITE	1
19	591043401	KIT DE EJES DE EQUILIBRIO	1
20	593104101	KIT DE LA PALANCA DEL ACELERADOR - CON BOMBA DE COMBUSTIBLE	1
21	591043501	KIT DE LA PALANCA DEL ACELERADOR - SIN CON BOMBA DE COMBUSTIBLE	1
22	591043801	KIT DEL TUBO DE LLENADO SIN CON BOMBA DE COMBUSTIBLE	1
23	593146701	KIT DEL TUBO DE LLENADO CON BOMBA DE COMBUSTIBLE	1
24	591043901	SPEED REGULATING ARM KIT	1
25	591044001	CONJUNTO DE LA BOBINA DE ENCENDIDO	1
26	591044101	KIT DEL RECTIFICADOR DE TENSIÓN	1
27	591044201	KIT DE LA PLACA LATERAL	1
28	591044301	KIT DEL PERNO	1
29	591044501	ENGRANAJE DEL REGULADOR	1
30	591044701	KIT DEL MOTOR DE ARRANQUE	1
31	592950701	KIT DEL CIGÜEÑAL	1
32	592950801	KIT DE LA ARMADURA DE CARGA	1
33	592950901	VOLANTE KIT	1
34	592951001	FILTRO DE ACEITE KIT	1
35	593168501	COMBUSTIBLE KIT DEL SISTEMA	1
36	591043101	KIT DEL TUBO DEL RESPIRADOR	1
37	591044601	CONJUNTO DEL ÁRBOL DE LEVAS	1



www.husqvarna.com