

Repair Parts Manual
Manual De Repuestos
YTH24V54 / 96045006900

Please read the operator's manual carefully and make sure you understand the instructions before using the machine.

Por favor lea cuidadosamente y comprenda estas instrucciones antes de usar esta maquina.



English/Spanish

115 94 44-49 Rev. 8



HOW TO USE THIS MANUAL

This manual is designed to provide the customer with a means to identify the parts on his/her tractor when ordering repair parts. The illustrations may or may not represent the actual assemblies; therefore, it is not recommended to use this manual as a guide to assemble or disassemble the tractor. Some hardware and parts are drawn larger in order to more readily identify them.

Each tractor has its own model number. The model number for your tractor can be found on the fender under the seat.

Support / Help

If you require assistance or have questions concerning the application, operation, maintenance or parts for your product:

- Visit our website: www.husqvarna.com
- Call Us Toll Free: 1-800-487-5951

When ordering parts, always give the following information:

- Product - "TRACTOR"
- MODEL NUMBER - "YTH24V54" (96045006900)"
- Part Number
- Part Description

TABLE OF CONTENTS

SCHEMATIC	3
ELECTRICAL	4-5
CHASSIS	6-7
DRIVE	8-9
ENGINE	10-11
STEERING	12-13
MOWER DECK	14-15
MOWER LIFT	16
SEAT	17
DECALS	18

COMO UTILIZAR ESTE MANUAL

Este manual está diseñado para brindarle al comprador un medio para identificar las piezas del tractor para cuando necesite hacer el pedido de un repuesto. Las ilustraciones pueden o no representar los ensambles reales; por lo tanto, no se recomienda utilizar este manual como una guía para ensamblar o desarmar el tractor. Algunos accesorios y piezas están dibujados en tamaños más grandes para identificarlos con mayor facilidad.

Cada tractor tiene su propio número de modelo. El número de modelo del tractor se encuentra en el guardabarros debajo del asiento.

Soporte / Ayuda

Si necesita asistencia o tiene alguna pregunta acerca de la aplicación, operación, mantenimiento o piezas de su producto:

- Visite nuestro sitio web: www.husqvarna.com
- Llámenos de manera gratuita al: 1-800-487-5951

Cuando haga el pedido de una pieza, siempre brinde la siguiente información:

- Producto: "TRACTOR"
- NÚMERO DE MODELO: "YTH24V54" (96045006900)"
- Número de pieza
- Descripción de la pieza

ÍNDICE

DIAGRAMA	19
DIAGRAMA ELÉCTRICO	20-21
CHASIS	22-23
TRANSMISIÓN	24-25
MOTOR	26-27
DIRECCIÓN	28-29
PLATAFORMA DE LA CORTADORA DE CÉSPED	30-31
ELEVACIÓN DE LA CORTADORA DE CÉSPED	32
ASIENTO	33
CALCOMANÍAS	34

TRACTOR - MODEL NO. YTH24V54 (96045006900), PRODUCT NO. 960 45 00-69 SCHEMATIC

SCH12

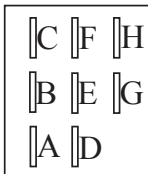
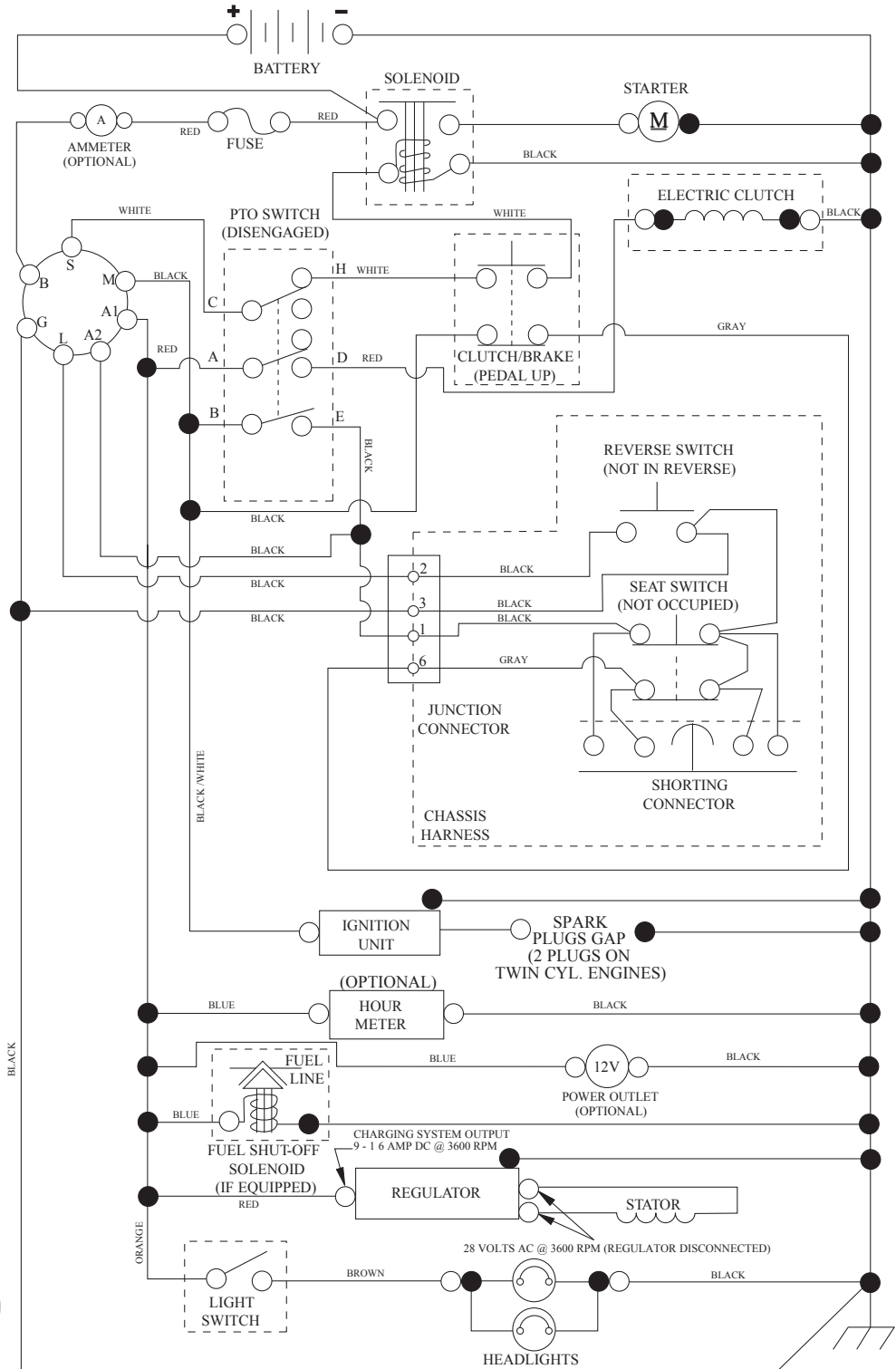

PTO SWITCH (MATING SIDE)

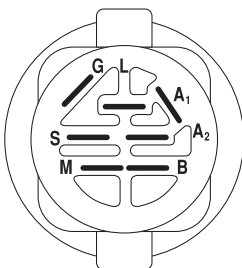

POSITION	CIRCUIT	"MAKE"
OFF	M+G+A1	
RUN/OVERRIDE	B+A1	
RUN	B+A1	L+A2
START	B + S + A1	

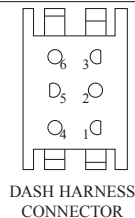
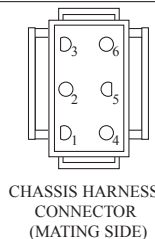

WIRING INSULATED CLIPS
NOTE: IF WIRING INSULATED CLIPS WERE REMOVED FOR SERVICING OF UNIT, THEY SHOULD BE RE-INSTALLED TO PROPERLY SECURE YOUR WIRING.

NON-REMOVABLE CONNECTIONS

REMOVABLE CONNECTIONS

**TRACTOR - MODEL NO. YTH24V54 (96045006900), PRODUCT NO. 960 45 00-69
ELECTRICAL**

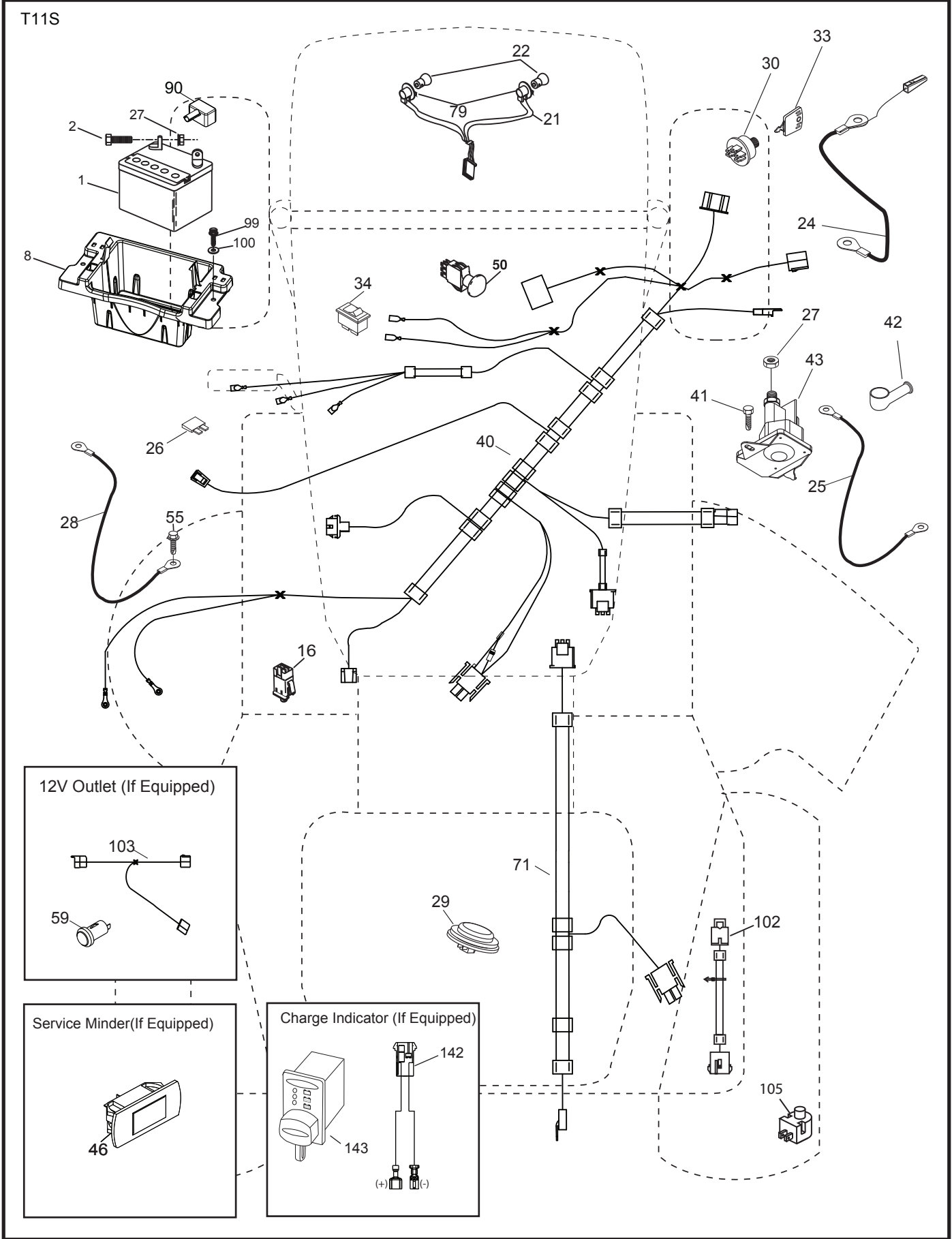

**TRACTOR - MODEL NO. YTH24V54 (96045006900), PRODUCT NO. 960 45 00-69
ELECTRICAL**

KEY NO.	PART NO.	DESCRIPTION
1	532 16 34-65	Battery
2	874 76 04-12	Bolt Hex Hd 1/4-20 unc x 3/4
8	532 41 41-26	Battery Tray
16	532 17 61-38	Switch Interlock
21	532 40 02-52	Harness Socket Light
22	532 00 41-52	Bulb, Light #1156
24	585 55 56-01	Cable Battery
25	585 55 55-01	Cable Starter
26	532 17 51-58	Fuse
27	596 13 36-01	Locknut, Keps. 1/4-20
28	532 41 65-88	Cable Ground 21" Blk 6 Ga.
29	532 40 15-45	Switch Seat
30	532 19 33-50	Switch Ign
33	532 41 19-33	Key/Chain
34	532 11 07-12	Switch Light/Reset
40	501 13 29-01	Harness Ign. Dash
41	817 72 04-08	Screw 1/4-20 x 1/2
42	532 13 15-63	Cover Terminal Red
43	582 04 28-02	Solenoid, W/Brass, Plunger, ZN
46	594 91 91-01	Hourmeter Delta
50	582 10 76-02	Switch, PTO. 8 Terminal, Std. Red
55	817 06 05-12	Screw Thdrol 5/16-18 x 3/4
71	532 19 42-76	Harness Ign
79	532 17 52-42	Socket Asm. Bulb Twistlock
90	532 43 53-95	Cover Terminal Battery
99	817 67 04-12	Screw Hexwsh Thdrol 1/4-20 x 3/4
100	596 13 53-01	Washer, Plain 9/32 x 7/8 Clr. Zn
102	532 40 44-54	Harness Pigtail
105	532 40 75-68	Switch Reverse TT Pedal Control

NOTE: All component dimensions given in U.S. inches
1 inch = 25.4 mm

**TRACTOR - MODEL NO. YTH24V54 (96045006900), PRODUCT NO. 960 45 00-69
CHASSIS**

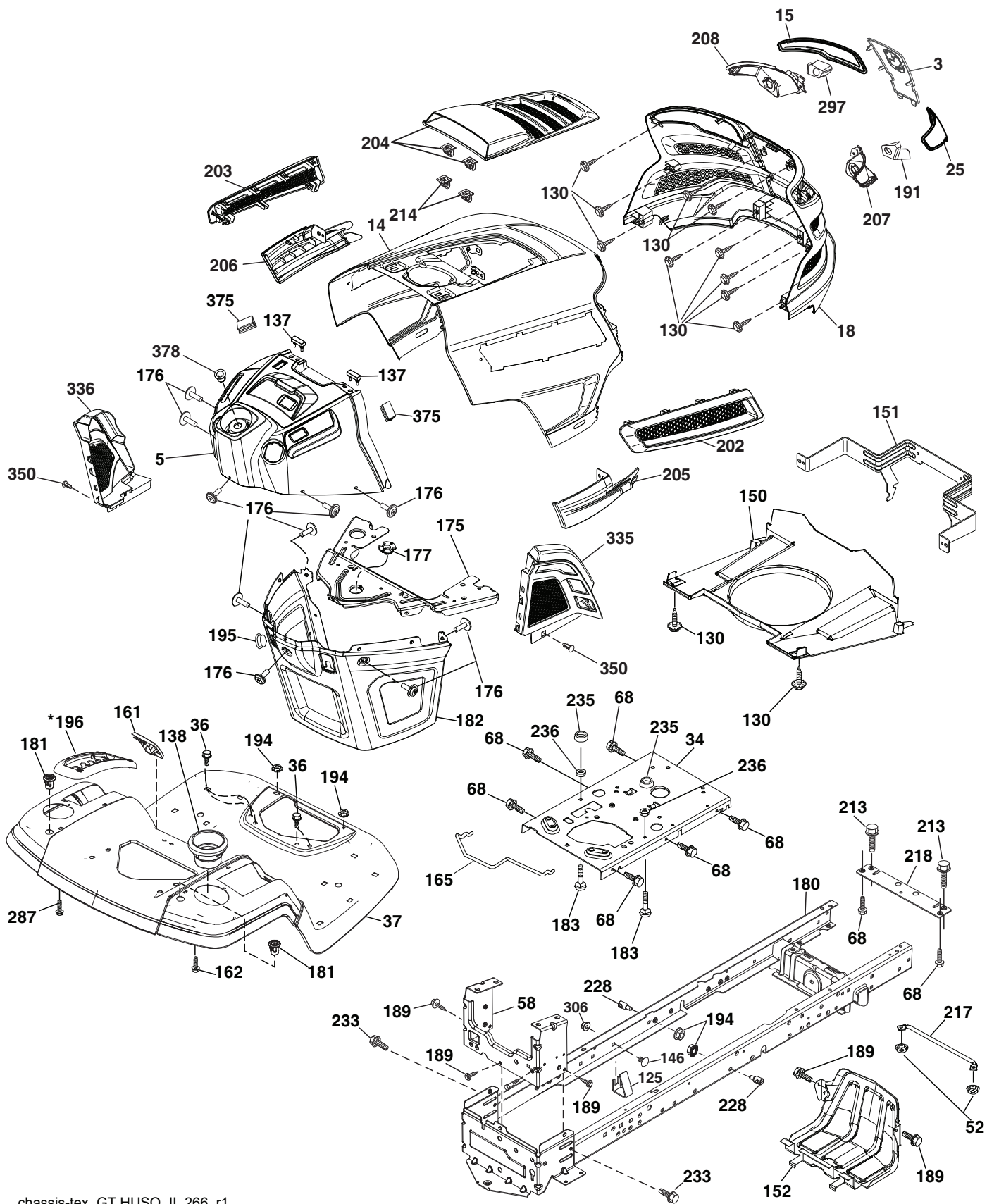

chassis-tex_GT HUSQ_II_266_r1

TRACTOR - MODEL NO. YTH24V54 (96045006900), PRODUCT NO. 960 45 00-69 CHASSIS

KEY NO.	PART NO.	DESCRIPTION	KEY NO.	PART NO.	DESCRIPTION
3	532 44 44-81	Logo	194	596 13 57-01	Nutlock, Prvl, Torq. 5/16-18 x .68
5	590 74 88-21	Dash	195	532 40 41-37	Plug Hole Dash Lower
14	532 44 11-77	Hood	*196	532 43 96-47	Tex Deck Lift Console
15	532 43 97-33	Lens LH	*196	596 86 92-01	Tex Deck Lift Console
18	587 52 34-01	Grille	202	532 43 97-28	Vent Side Hood RH
25	532 44 33-85	Lens RH	203	532 43 97-27	Vent Side Hood LH
34	580 91 08-01	Plate Engine	204	587 48 58-01	Vent, Top, Asm.
36	817 06 05-12	Screw 5/16-18 x 3/4	205	532 43 97-30	Trim Hood Side RH
37	532 44 12-69	Fender	206	532 43 97-29	Trim Hood Side LH
52	596 04 05-01	Nutlock, Hex. Prvl. 5/16-18	207	587 46 48-01	Bezel RH
58	532 41 22-80	Drawbar Upper	208	587 46 45-01	Bezel LH
68	596 03 07-01	Screw, Hexagon, 5/16-18 x 1/2	213	596 03 05-01	Bolt, Hex. Hd. 5/16-18 unc x 3/4
125	581 68 48-01	Clip Fuel Line	214	532 19 91-45	Clip Retainer Tinner
130	596 32 17-01	Screw, #10 x 0.750 BOS Thread	217	532 40 91-67	Rod Pivot
137	532 40 75-90	Bumper Dash	218	532 19 63-95	X-Piece Hood Stop
138	532 43 97-47	Cup Holder	228	593 82 40-01	Stud, W/"D" Anti-rotation
146	581 85 79-01	Bolt 3/8-16 x 5/8	233	532 19 65-39	Bolt, Shoulder
150	532 43 97-74	Air Duct	235	596 56 42-01	Spacer, Fender, Clr. Zn
151	532 43 66-70	Bracket Pivot	236	873 93 05-00	Nut Lock 5/16-18 unc
152	532 43 98-70	Shield Browning	287	817 60 04-06	Screw Hex Washhead 1/4-20 x 3/8
161	532 43 97-81	Window Fuel	297	532 43 74-56	Insert Reflective LH
162	596 13 41-01	Screw, Hex. Tap. 1/4-15 x 1/2	306	873 90 06-00	Nut Lock 3/8-16 unc
165	532 19 68-26	Support Tank Rear	335	532 44 82-04	Cover Lower Dash Close Out RH
175	590 60 77-02	Crossmember	336	532 44 53-09	Cover Lower Dash LH
176	532 40 07-76	Screw 10-24 x 5/8	350	532 44 51-43	Clip X-mas Tree
177	532 19 52-28	Bushing Steering	375	586 90 82-01	Dash Clip-On Bumper
180	532 41 50-63	Chassis	378	590 84 98-01	Bushing, Flange, Plastic
181	532 43 97-46	Bushing			
182	532 40 68-59	Dash Lower			
183	595 30 57-01	Screw, Hexagon, 5/16-18 x 1-1/4			
189	817 00 05-12	Screw 3/8-16 3/4			
191	532 43 74-55	Insert Reflective RH			

NOTE: All component dimensions given in U.S. inches
1 inch = 25.4 mm

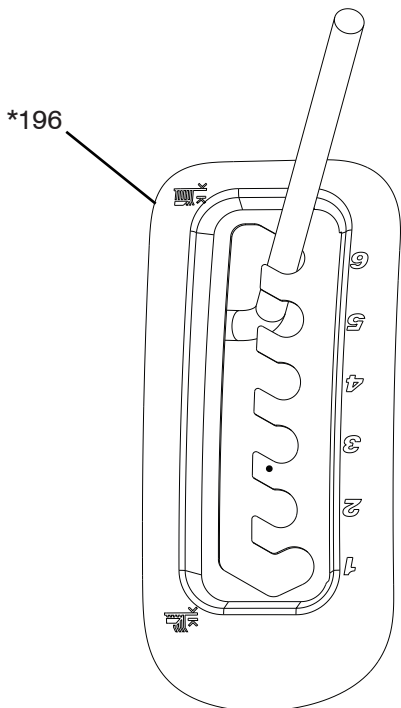

*196 532 43 96-47 Tex Deck Lift Console

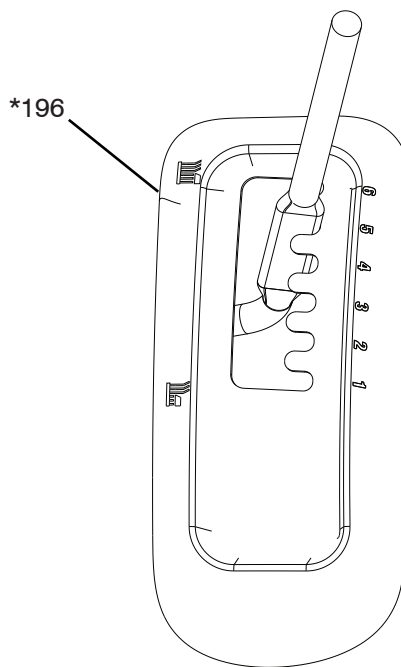

*196 596 86 92-01 Tex Deck Lift Console

TRACTOR - MODEL NO. YTH24V54 (96045006900), PRODUCT NO. 960 45 00-69 DRIVE

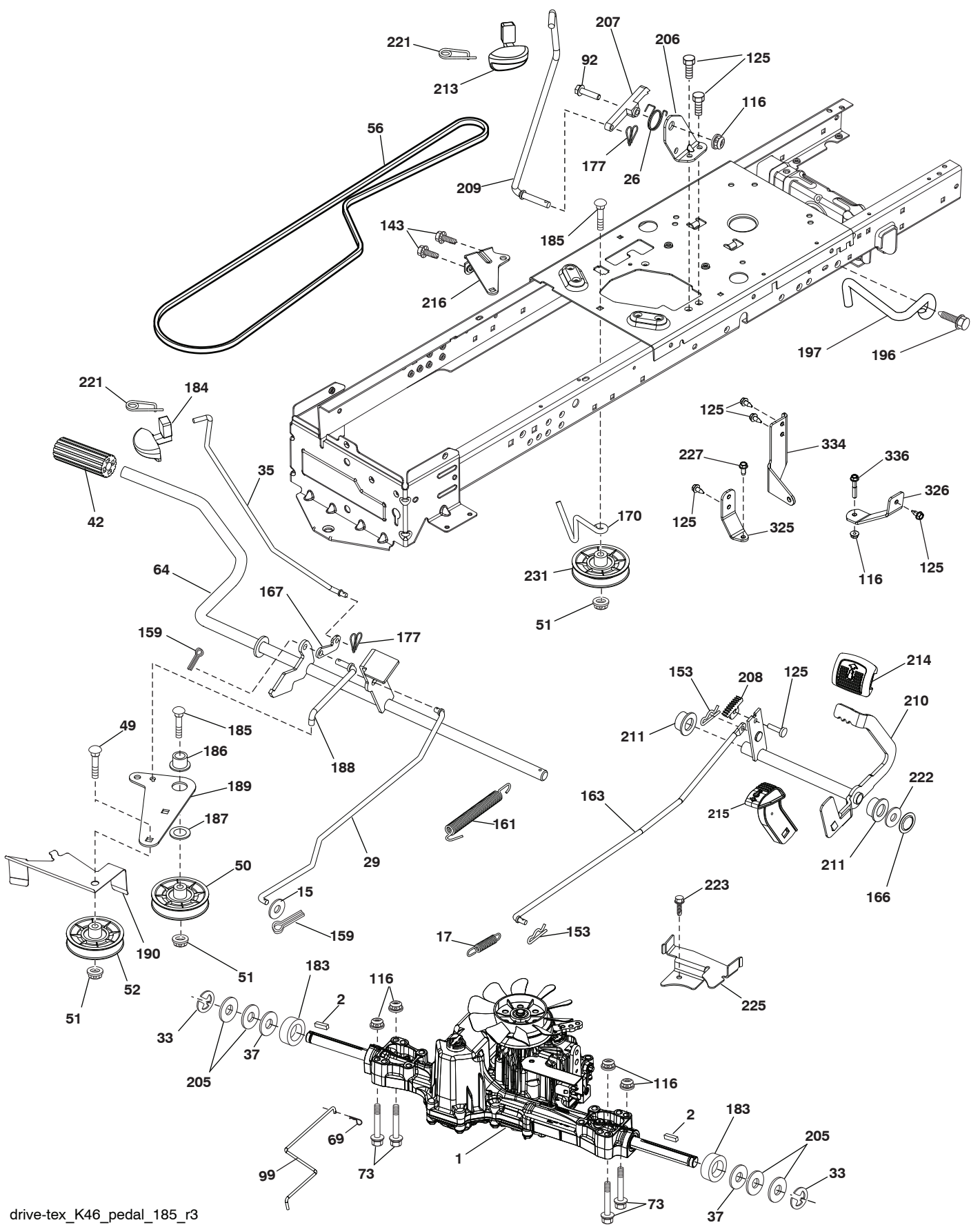

drive-tex_K46_pedal_185_r3

TRACTOR - MODEL NO. YTH24V54 (96045006900), PRODUCT NO. 960 45 00-69 DRIVE

KEY NO.	PART NO.	DESCRIPTION	KEY NO.	PART NO.	DESCRIPTION
1	---	Transaxle, Tufftorq K46BT(426120) (Order parts from transaxle manu facturer.)	184	587 65 37-01	Handle Parking Brake
2	532 12 35-83	Key Square	185	872 11 06-22	Bolt
15	596 56 53-01	Washer, 3/8 x 0.08 in. St. Clr. Zinc	186	532 19 43-21	Spacer Retainer
17	532 41 36-78	Spring, Brake	187	596 13 55-01	Washer, 13/32 x 2 Clear, Zinc
26	532 19 96-79	Spring Return Cruise	188	582 21 70-01	Link Clutch Ground Drive
29	532 40 38-06	Rod, Brake	189	532 19 43-17	Bellcrank Ground Drive
33	812 00 00-01	Ring E	190	532 19 43-18	Keeper Bellcrank Ground Drive
35	590 60 59-02	Rod, Brake, Park	196	817 00 06-16	Screw 3/8-16 x 1
37	532 18 89-67	Washer Harden .793 x 1.637 x 060	197	585 65 86-02	Wireform, Clutch, AntiRotation
42	532 00 88-83	Cover, Foot Pedal	205	532 12 17-48	Washer 25/32 x 1-5/8 x 16 Ga.
49	596 13 62-01	Bolt, Cup Head, 3/8-16 x 3/4	206	532 44 85-96	Bracket Mount Latch Cruise
50	532 19 43-27	Pulley Idler Flat	207	587 03 14-02	Latch, Cruisecontrol, Tex. Clr.
51	873 90 06-00	Lock Nut 3/8-16	208	596 56 41-01	Gear
52	532 19 43-26	Idler V-Groove 910" Offset	209	590 52 78-02	Rod Control Cruise
56	592 85 52-01	V-Belt, Drive	210	532 40 09-80	Rocker Asm. Pedal Control
64	532 19 78-65	Shaft Asm. Pedal Brake Control	211	532 12 01-83	Bearing Nylon
69	532 42 33-03	Hairpin Soft Zinc .059 x 1.125	213	532 40 31-19	Knob Control Cruise
73	596 13 65-01	Bolt, Hex. Head, 5/16-18 x 1-1/2	214	532 42 12-63	Pedal Forward Pad
92	595 30 57-01	Screw, Hexagon, 5/16-18 x 1-1/4	215	586 60 65-02	Pedal Reverse
99	582 40 45-01	Rod Bypass LT K46, K57	216	532 19 61-31	Bracket Pulley Idler
116	596 13 57-01	Nutlock, Prvl. Torq. 5/16-18 x .68	221	532 40 31-87	Retainer Spring Clip Handle
125	817 00 05-12	Screw 5/16-18 x 3/4	222	879 21 20-10	Washer 21/32 x 1-1/4 10 Ga.
143	596 03 07-01	Screw, Hexagon, 5/16-18 x 1/2	223	598 66 26-01	Bolt, T45. 5/16-18 x .75 Hexhd Blk
153	532 00 44-97	Retainer Spring 1"	225	532 40 33-19	Keeper Belt Transaxle
159	596 02 95-01	Pin, Cotter, 1/8 Dia. x 3/4	227	596 13 59-01	Bolt, Hex. 5/16-18 x 3/4 Clr. Znc
161	532 10 57-09	Spring, Return, Clutch	231	532 40 72-87	Idler V-Groove
163	593 86 10-01	Rod, Control, K46/K57R	325	586 00 11-02	Torque Brkt RH
166	532 42 91-64	Nut Push	326	586 43 12-02	Torque Strap LH
167	532 40 52-57	Latch Brake Parking	334	585 88 22-02	Sway Rod Bracket
170	532 41 34-30	Keeper Center Span	336	596 13 57-01	Nutlock, Prvl, Torq. 5/16-18 x .68
177	587 22 53-01	Pin, Cotter, Locking, Bowtie, 1 In.			
183	532 13 70-57	Spacer Axle			

NOTE: All component dimensions given in U.S. inches
1 inch = 25.4 mm

**TRACTOR - MODEL NO. YTH24V54 (96045006900), PRODUCT NO. 960 45 00-69
ENGINE**

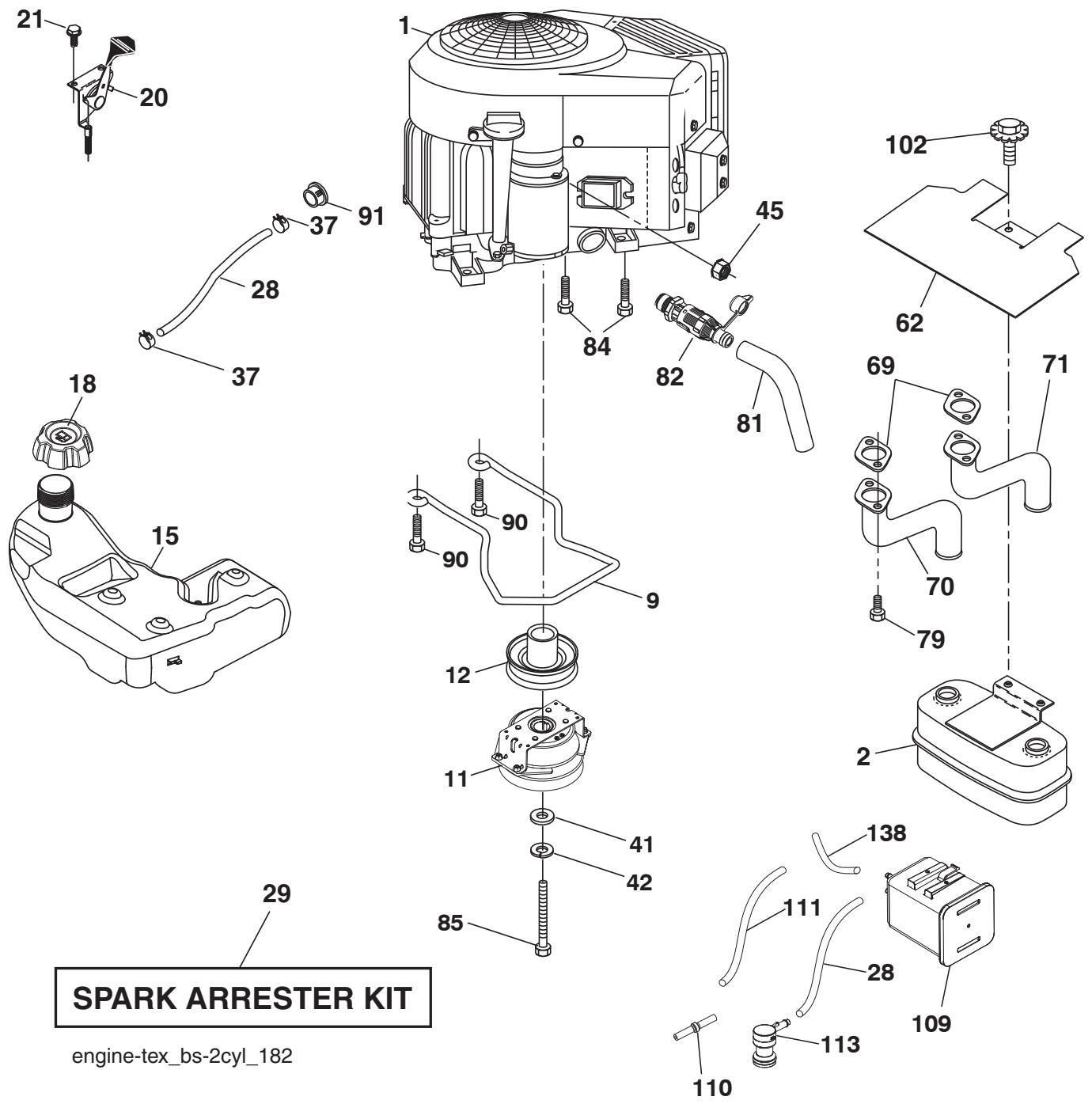

TRACTOR - MODEL NO. YTH24V54 (96045006900), PRODUCT NO. 960 45 00-69 ENGINE

KEY NO.	PART NO.	DESCRIPTION
1	-----	Engine Briggs Model No. 44N877-0003-G1 (501259701) (Order parts from engine manufacturer.)
2	589 81 87-01	Muffler
9	501 83 26-02	Keeper Belt Engine
11	587 24 16-01	Clutch Electric
12	532 40 50-97	Pulley Engine
15	599 83 76-01	Fuel, Tank, Asm. 3 Gal. Rr 2020
18	599 50 22-01	Fuel, Cap, Asm. 3" W/Grease
20	587 24 25-01	Control Throttle/Choke
21	596 32 17-01	Screw, #10 x 0.750 BOS Thread
28	532 40 11-35	Fuel Line
29	532 13 71-80	Spark Arrester Kit
37	532 12 34-87	Clamp Hose
41	532 12 61-97	Washer 1-1/2 OD x 15/32 ID x .250
42	596 23 89-01	Washer, 7/16 in. Clr. Zn
45	596 13 36-01	Locknut, Keps. 1/4-20
62	532 43 40-17	Shield Heat Muffler
69	532 16 53-91	Gasket
70	581 88 11-01	Tube Exhaust LH
71	581 88 10-01	Tube Exhaust RH
79	596 13 42-02	Screw, Hex. Socket, 5/16-18 x 3/4
81	532 14 84-56	Tube Drain Oil Easy
82	532 42 82-87	Valve Oil Drain
84	817 06 06-20	Screw 3/8-16 x 1-1/4
85	501 60 66-01	Bolt Hx 7/16-20 x 3.75 Gr. 5
90	817 00 06-16	Screw 3/8-16 x 1
91	532 18 74-95	Bushing
102	817 00 05-12	Screw 5/16-18 x 3/4
109	532 41 41-14	Canister Carbon Filter
110	532 41 41-18	Valve Anti-Slosh
111	596 94 15-01	Tube, Purge, Fuel .1875"
113	532 41 41-27	Valve Slant Cartridge
138	532 42 07-18	Purge Line Rear

NOTE: All component dimensions given in U.S. inches
1 inch = 25.4 mm

For engine service and replacement parts, call the toll free number for your engine manufacturer listed below:

Briggs & Stratton 1-800-233-3723

Engine Power Rating Information

The gross power rating for individual gas engine models is labeled in accordance with SAE (Society of Automotive Engineers) code J1940 (Small Engine Power & Torque Rating Procedure), and rating performance has been obtained and corrected in accordance with SAE J1995 (Revision 2002-05). Torque values are derived at 3060 RPM; horsepower values are derived at 3600 RPM. Actual gross engine power will be lower and is affected by, among other things, ambient operating conditions and engine-to-engine variability. Given both the wide array of products on which engines are placed and the variety of environmental issues applicable to operating the equipment, the gas engine will not develop the rated gross power when used in a given piece of power equipment (actual "on-site" or net power). This difference is due to a variety of factors including, but not limited to, accessories (air cleaner, exhaust, charging, cooling, carburetor, fuel pump, etc.), application limitations, ambient operating conditions (temperature, humidity, altitude), and engine-to-engine variability. Due to manufacturing and capacity limitations, Briggs & Stratton may substitute an engine of higher rated power for this Series engine.

TRACTOR - MODEL NO. YTH24V54 (96045006900), PRODUCT NO. 960 45 00-69
STEERING ASSEMBLY

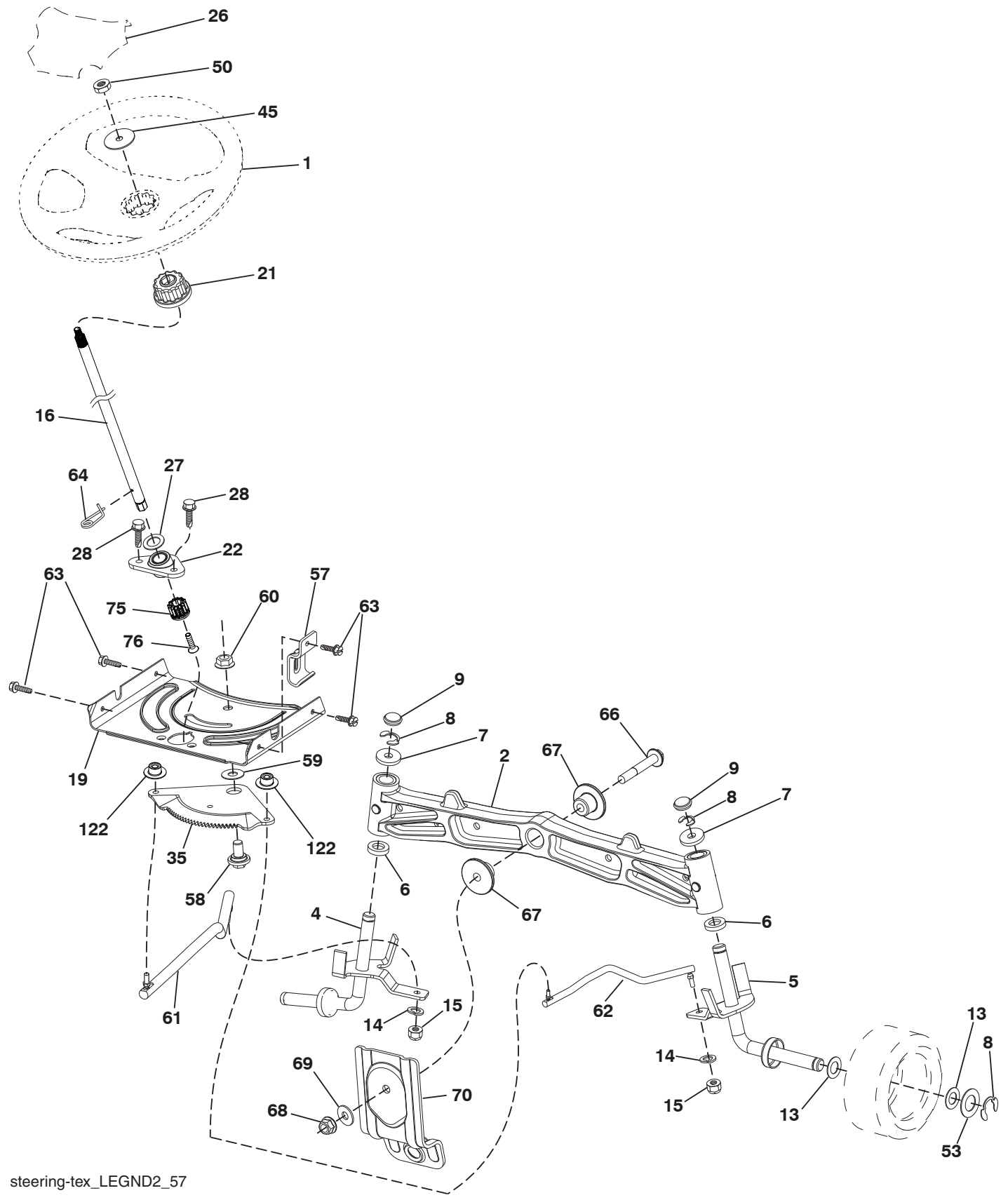

steering-tex_LEGND2_57

**TRACTOR - MODEL NO. YTH24V54 (96045006900), PRODUCT NO. 960 45 00-69
STEERING ASSEMBLY**

KEY NO.	PART NO.	DESCRIPTION
1	532 43 97-40	Wheel, Steering
2	532 19 59-68	Axle Asm., Front
4	532 40 30-87	Spindle Asm., LH
5	532 40 30-88	Spindle Asm., RH
6	532 00 62-66	Washer, Thrust .75 x 1.230
7	532 12 17-48	Washer 25/32 x 1-5/8 x 16 Ga.
8	812 00 00-29	Ring, Clip #T5304-75
9	532 12 12-32	Cap, Spindle
13	532 12 17-49	Washer 25/32 x 1-1/4 x 16 Ga.
14	596 23 87-01	Washer, Spring, Lock, .381 ID x .680
15	873 54 06-00	Nut, Crown Lock 3/8-24 unf
16	587 01 60-02	Steering Shaft
19	532 19 47-29	Plate Steering
21	586 84 02-01	Adapter Wheel Steering
22	585 02 98-02	Bearing
26	532 43 97-43	Insert, Wheel Steering
27	596 93 34-01	Washer, Plain
28	817 00 06-12	Screw 3/8-16 x 3/4
35	532 19 47-32	Gear, Sector Plate
45	587 01 64-01	Washer 3/8 ID 2-3/8 OD 12 Ga. PLTD
50	873 90 06-00	Nut Lock Flg 3/8-16 unc
53	532 18 89-67	Washer Hardened .793 x 1.637 x .060
57	532 19 72-46	Bracket Upstop
58	532 19 47-47	Bolt Shoulder Sector Pivot CFM
59	532 19 47-48	Washer Thrust Sector Steering
60	873 97 10-00	Nut Flange Lock 5/8-11
61	532 19 47-40	Draglink, LH
62	532 19 47-41	Draglink, RH
63	817 00 05-12	Screw 5/16-18 x 3/4
64	532 19 98-49	Retainer Clip Spring Steering
66	871 02 07-48	Bolt Hex Fghd 7/16-14 x 3 Serr
67	532 19 47-37	Bushing PM Front Axle
68	873 90 07-00	Nut Lock Flange 7/16-14 Gr. 5
69	532 19 91-62	Washer 1.5 x .505 x .118
70	585 33 88-01	Bracket Deck Susp. Front
75	580 68 37-01	Pinion
76	580 68 36-01	Screw Head Sock
122	532 44 49-62	Cap Gear Sector

NOTE: All component dimensions given in U.S. inches
1 inch = 25.4 mm

TRACTOR - MODEL NO. YTH24V54 (96045006900), PRODUCT NO. 960 45 00-69
MOWER DECK

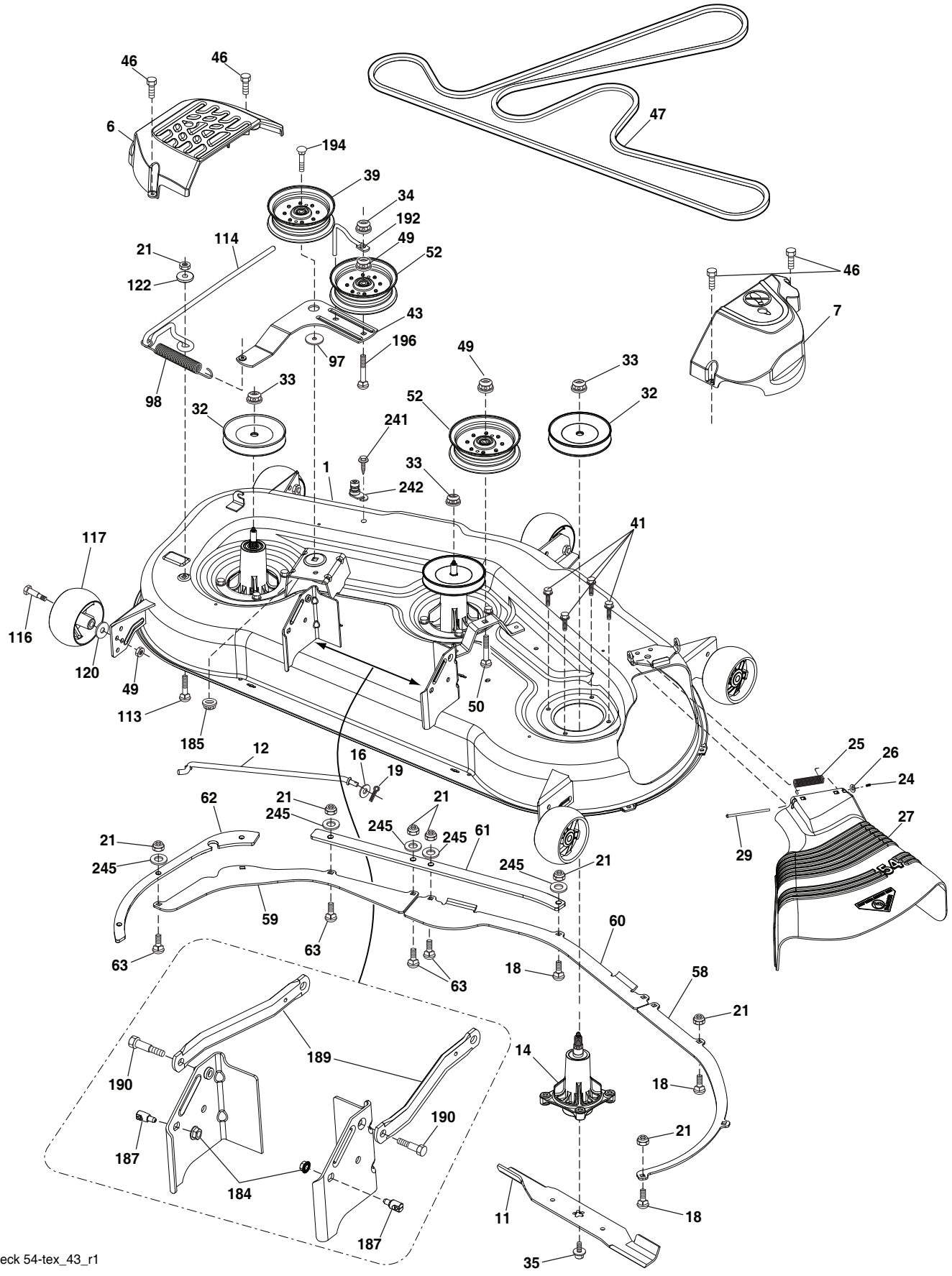

mower_deck 54-tex_43_r1

**TRACTOR - MODEL NO. YTH24V54 (96045006900), PRODUCT NO. 960 45 00-69
MOWER DECK**

KEY NO.	PART NO.	DESCRIPTION	KEY NO.	PART NO.	DESCRIPTION
1	532 41 82-30	Kit. SVC. Weldment	62	585 32 28-05	Plate Reinforcement Side
6	532 19 60-66	Cover Mandrel LH	63	872 11 05-10	Bolt Carr. 5/16-18 x 1-1/4 Gr. 5
7	532 19 71-81	Cover Mandrel RH	97	532 17 85-15	Washer Hardened
11	532 18 72-56	Blade Bagging	98	532 19 61-05	Spring Drive
12	532 40 48-51	Rod Anti Sway	113	596 43 57-01	Bolt Sqr. 5/16-18 x 1.02 Gr. 5
14	587 82 03-01	Kit, Mandrel, Greaseable, Tall (includes mandrel and bolts)	114	532 18 75-56	Rod Tension Relief
16	596 13 32-01	Washer, 13/32 x 13/16 x 12 Ga.	116	596 43 44-04	Bolt, shoulder 3/8-16 x 3-5/8"
18	596 13 64-01	Bolt, Cup, head 5/16-18 x 5/8	117	589 52 73-01	Gauge Wheel
19	532 19 42-08	Pin Cotter 5/16 Bowtie	120	596 13 49-01	Washer, Plain 3/8 x 7/8
21	596 04 05-01	Nut, Lock, Hex. Prvl 5/16-18	122	532 18 75-57	Bushing Tension Relief
24	532 10 53-04	Cap Sleeve	184	596 13 57-01	Nut, Lock, Prvl. Torq 5/16-18 x .68
25	532 17 81-02	Spring, Torsion	185	873 90 07-00	Nut Lock Flange 7/16-14 Gr. 5
26	532 11 04-52	Nut, Push	187	593 82 40-01	Stud, W/"D" Anti-rotation
27	532 18 89-38	Deflector Shield	189	587 14 05-02	Arm Susp. Mower Rear
29	595 29 70-01	Rod, Hinge	190	532 19 65-39	Bolt Shoulder
32	532 15 35-35	Pulley, Mandrel	192	532 19 84-68	Keeper Belt Idler
33	596 13 48-01	Nut, Hex 9/16-18 x 1.010	194	874 49 07-36	Bolt Carr Sqnk 7/16-24 x 2
34	596 32 26-01	Nut, Crownlock 3/8 - 16 unc	196	596 33 78-01	Bolt, Carriage 3/8-16 x 2-1/2
35	584 30 93-01	Screw 7/16-20 x 1	241	532 15 29-27	Screw
39	532 19 73-80	Pulley, Idler, Stationary LH	242	532 41 55-98	Washout Port
41	584 95 39-01	Bolt Hx Wsh Hd 3/16-18 x 1.19	245	596 20 41-01	Washer 11/32 x 11/16 x 14
43	532 19 60-65	Arm, Idler	--	532 41 64-05	Coupling, Quick Connect
46	532 13 77-29	Screw, Thdroll. 1/4-20 x 5/8	--	532 41 82-29	Replacement Mower, Complete
47	587 68 67-01	Belt Deck Drive			
49	873 90 06-00	Nut, Lock Flg. 3/8-16 unc			
50	596 13 63-01	Bolt, Cup Head 3/8-16 x 2			
52	532 19 73-79	Pulley Idler			
58	532 18 73-42	Baffle Right			
59	532 18 73-44	Baffle Left			
60	532 18 76-07	Baffle Center			
61	585 32 26-05	Plate Reinforcement Front			

NOTE: All component dimensions given in U.S. inches
1 inch = 25.4 mm

**TRACTOR - MODEL NO. YTH24V54 (96045006900), PRODUCT NO. 960 45 00-69
MOWER LIFT**

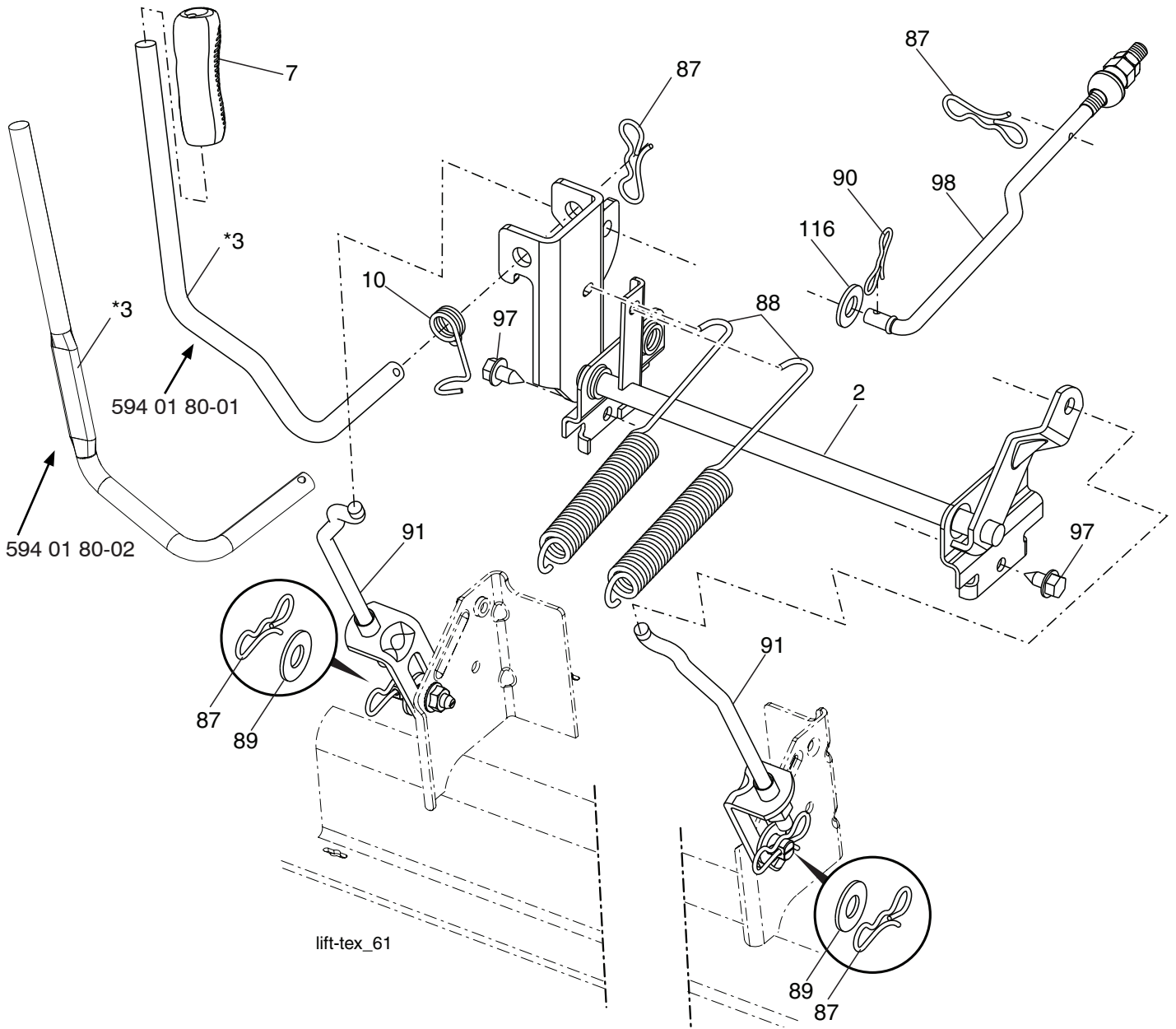

KEY NO.	PART NO.	DESCRIPTION
2	532 42 20-27	Shaft Asm. Cross, Lift
*3	594 01 80-01	Handle, Liflever, Lt. Std. Wide
*3	594 01 80-02	Handle, Liflever, LT. Flat, Narrow
7	580 96 23-01	Grip, Lever
10	532 19 63-14	Spring Torsion
87	532 19 42-09	Pin Cotter 7/16 Bow Tie Lock
88	532 41 07-10	Spring Lift Assist
89	819 19 19-12	Washer Clear Zinc
90	532 19 42-08	Pin Cotter 5/16 Bow Tie Lock

KEY NO.	PART NO.	DESCRIPTION
91	589 46 48-05	Link, Assy. Lift, Rear 10.540 Blue
97	817 00 06-12	Screw 3/8-16 x .75
98	581 50 69-02	Link, Assy. Mwr. Front, Suspension, 9.820
116	594 97 65-01	Washer Round 15/32 x 15/16 x .065.

NOTE: All component dimensions given in U.S. inches
1 inch = 25.4 mm

**TRACTOR - MODEL NO. YTH24V54 (96045006900), PRODUCT NO. 960 45 00-69
SEAT ASSEMBLY**

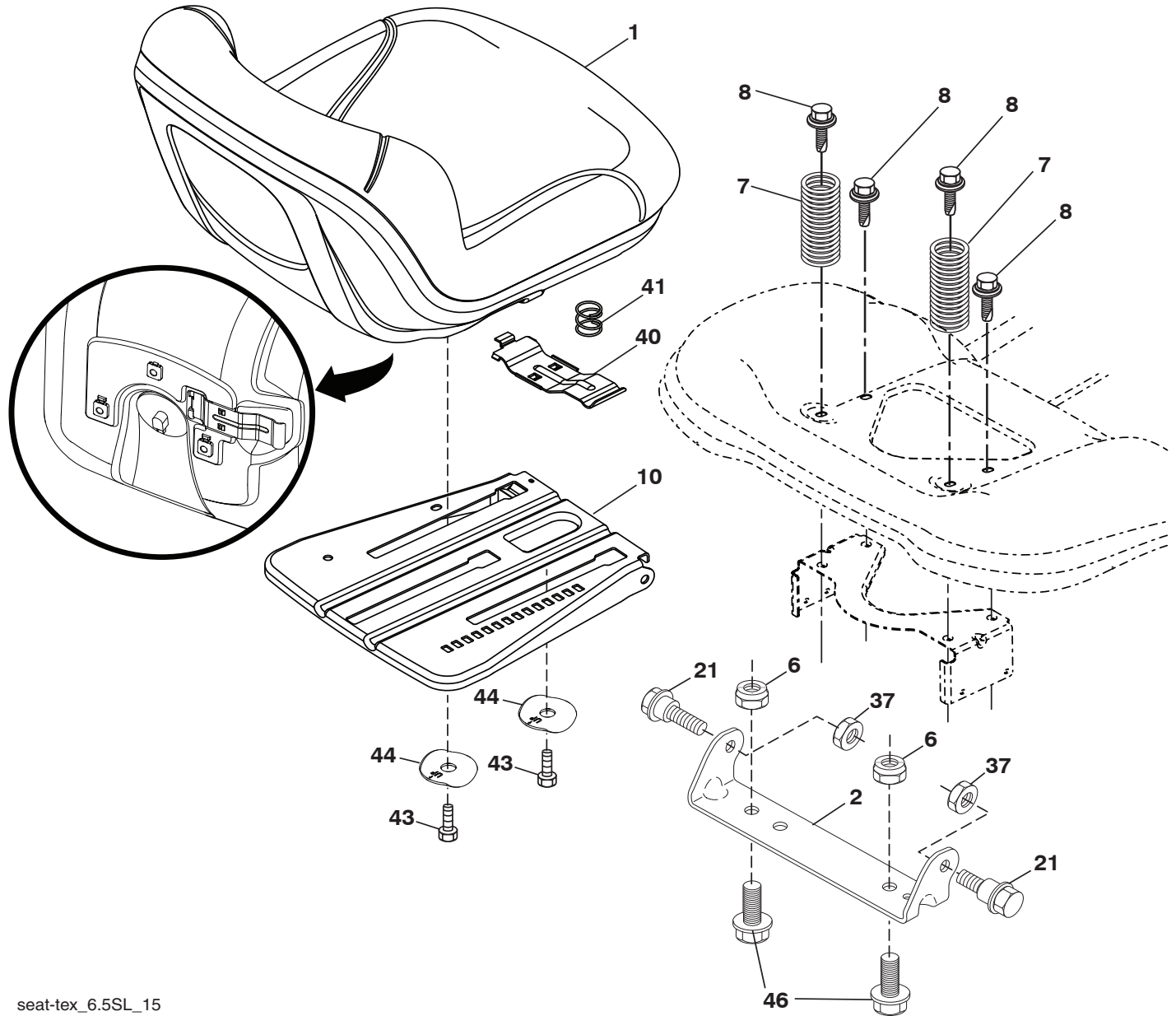

seat-tex_6.5SL_15

KEY NO.	PART NO.	DESCRIPTION
1	532 43 98-22	Seat
2	532 18 01-66	Bracket Pivot Fender
6	873 80 06-00	Nut, Lock w/Ins. 3/8-16 unc
7	589 48 35-01	Spring, Seat Cprsn
8	532 17 18-77	Bolt 5/16-18 unc x 3/4 w/Sems
10	596 65 74-02	Plate, Seat
21	587 90 78-01	Bolt, Shoulder 5/16-18 x 5/8
37	596 58 37-02	Nut 5/16-18 Nyloc. Blk. Zinc
40	595 08 81-02	Handle, Seat, Slide, E-Dip, x 431

KEY NO.	PART NO.	DESCRIPTION
41	532 19 82-00	Spring Latch Seat
43	874 76 06-12	Bolt 3/8-16 x 3/4
44	501 05 18-01	Washer Winged 3/8 ID 1.5 OD
46	588 09 04-01	Bolt 3/8-16 x 1, 1.25

NOTE: All component dimensions given in U.S. inches
1 inch = 25.4 mm

**TRACTOR - MODEL NO. YTH24V54 (96045006900), PRODUCT NO. 960 45 00-69
DECALS**

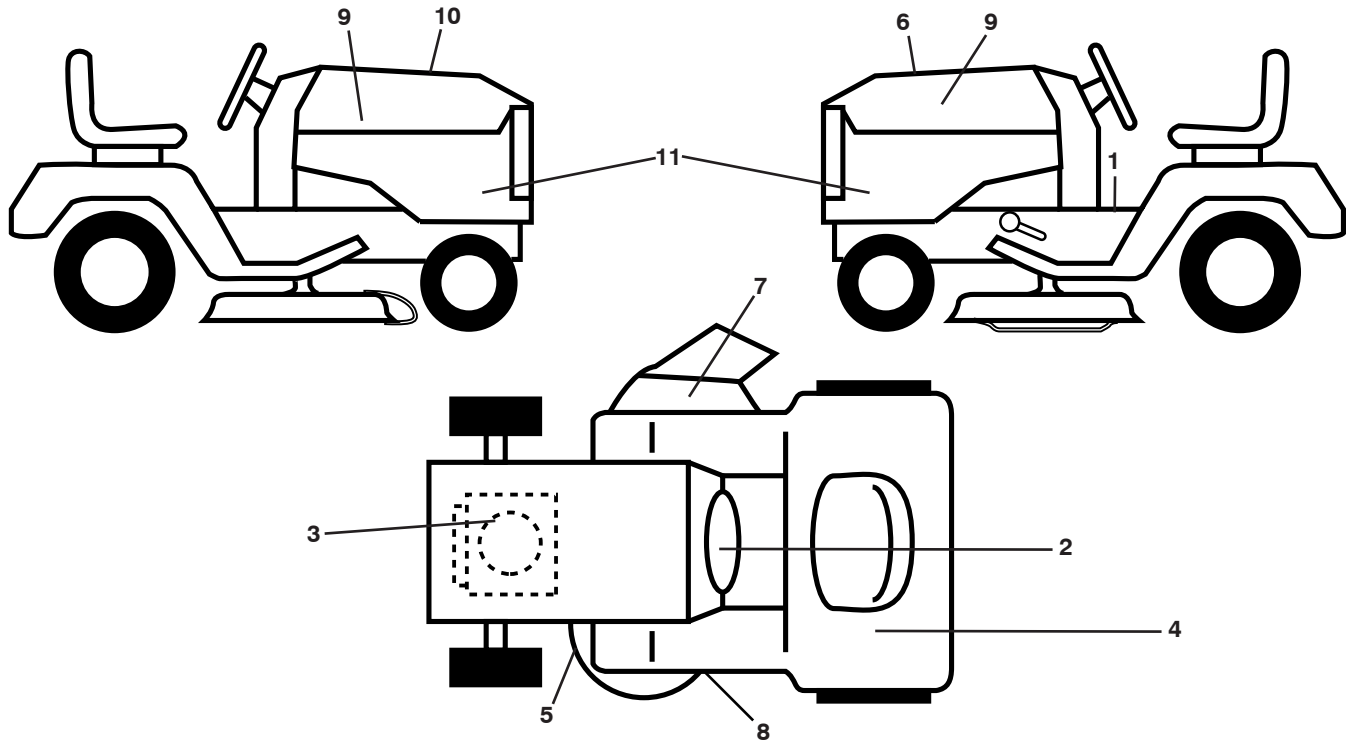

KEY NO.	PART NO.	DESCRIPTION	KEY NO.	PART NO.	DESCRIPTION
1	586 71 38-01	Decal, Warning	11	586 01 34-01	Decal, Panel Side
2	596 02 42-01	Decal, Warning Spark	--	581 72 48-01	Decal, Bypass
3	585 93 73-01	Decal, Engine H.P.	--	532 43 96-81	Pad, Footrest, LH
4	580 88 58-01	Decal, E85 Warning	--	532 43 96-82	Pad, Footrest, RH
5	581 72 45-02	Decal, Caution	--	115 94 43-49	Manual, Operator's (English/Spanish)
6	591 44 63-01	Decal, Replacement	--	115 94 44-49	Manual, Parts (English/Spanish)
7	584 90 46-01	Decal, Deflect. Warning	--	587 71 00-26	Manual, QSG (English/Spanish)
8	581 58 00-02	Decal, Mower Sch.			
9	581 62 73-01	Decal, Hood Logo			
10	532 42 38-29	Decal, Cust. Resp.			

WHEELS AND TIRES

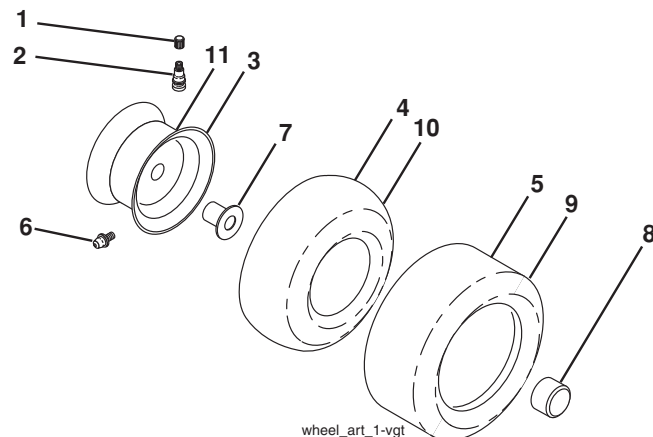

wheel_art_1-vgt

KEY NO.	PART NO.	DESCRIPTION
1	532 05 91-92	Cap, Valve, Tire
2	532 06 51-39	Stem, Valve
3	532 13 83-36	Rim Assembly, Front
4	532 05 99-04	Tube, Front (Service Item Only)
5	532 10 62-22	Tire, Front 15 x 6-6
6	532 00 02-78	Fitting, Grease (Front Wheel Only)
7	532 00 90-40	Bearing, Flange (Front Wheel Only)
8	532 17 50-39	Cap, Axle
9	532 13 84-68	Tire, Rear 20 x 8-8
10	532 00 71-52	Tube, Rear (Service Item Only)
11	532 13 83-37	Rim Assembly, Rear
--	532 14 43-34	Sealant, Tire (10 oz. Tube)

NOTE: All component dimensions given in U.S. inches
1 inch = 25.4 mm

TRACTOR - MODELO NO. YTH24V54 (96045006900), PRODUCT NO. 960 45 00-69

DIAGRAMA

SCH12-s

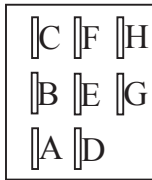
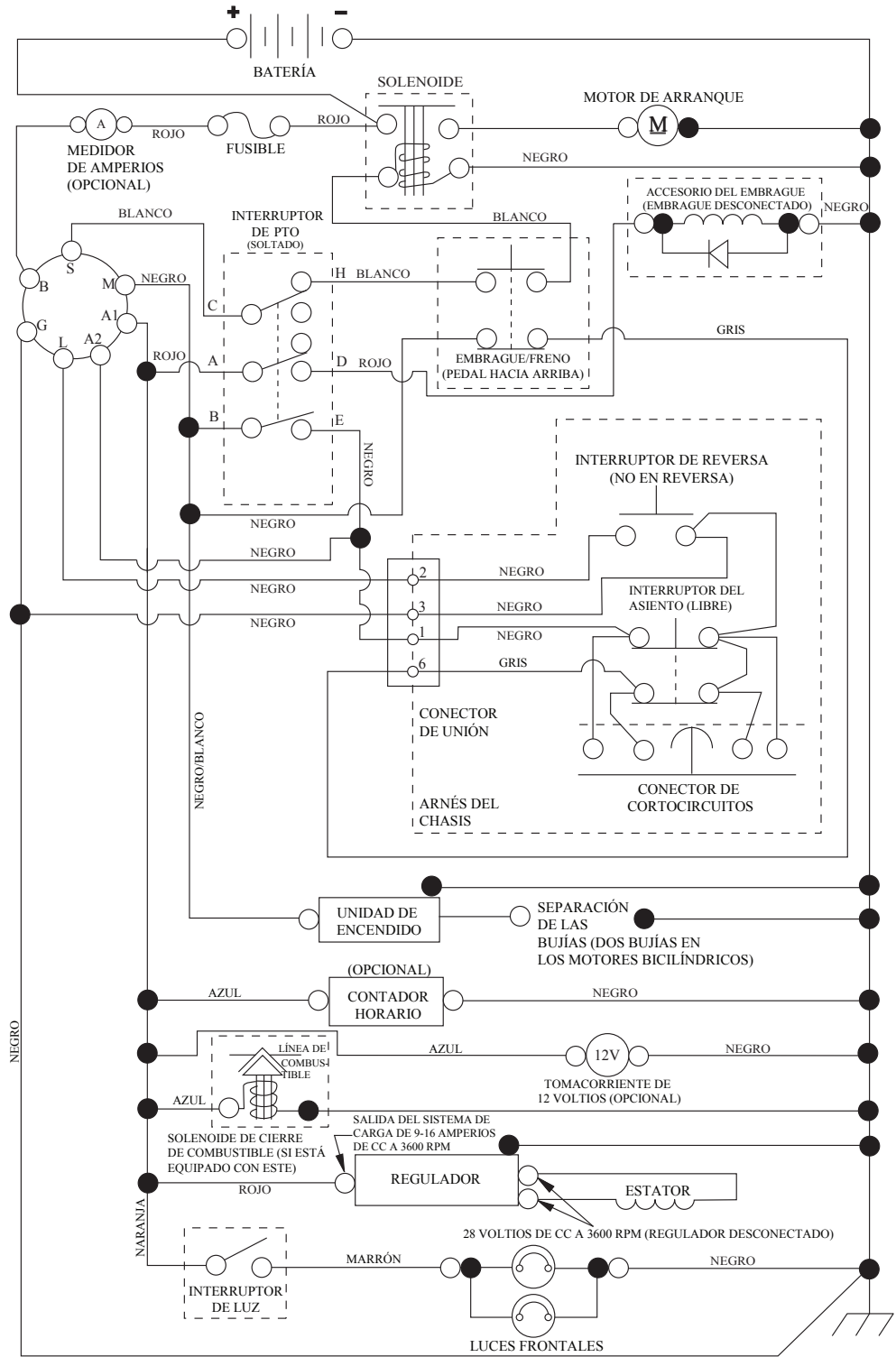

INTERRUPTOR DE PTO (CARA DE ACOPLAMIENTO)

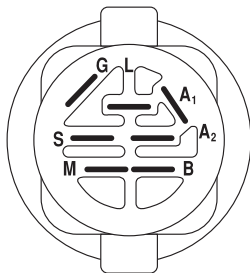

INTERRUPTOR DE ENCENDIDO

POSICIÓN	CIRCUITO «MARCA»
APAGADO	M+G+A1
PONER EN FUNCIONAMIENTO/ANULAR	B+A1
PONER EN FUNCIONAMIENTO	B+A1 L+A2
ARRANCAR	B + S + A1



CONEXIÓN DEL ARNÉS DEL CHASIS (LATERAL QUE COINCIDA)



CONEXIÓN PARA EL ARNÉS DEL TABLERO

NOTA SOBRE LAS ABRAZADERAS DE AISLAMIENTO DEL CABLEADO: SI SE QUITAN LAS ABRAZADERAS DE AISLAMIENTO DEL CABLEADO PARA HACER EL MANTENIMIENTO DE LA UNIDAD, SE LAS DEBERÁ INSTALAR NUEVAMENTE PARA PROTEGER EL CABLEADO ADECUADAMENTE.



DIAGRAMA ELÉCTRICO

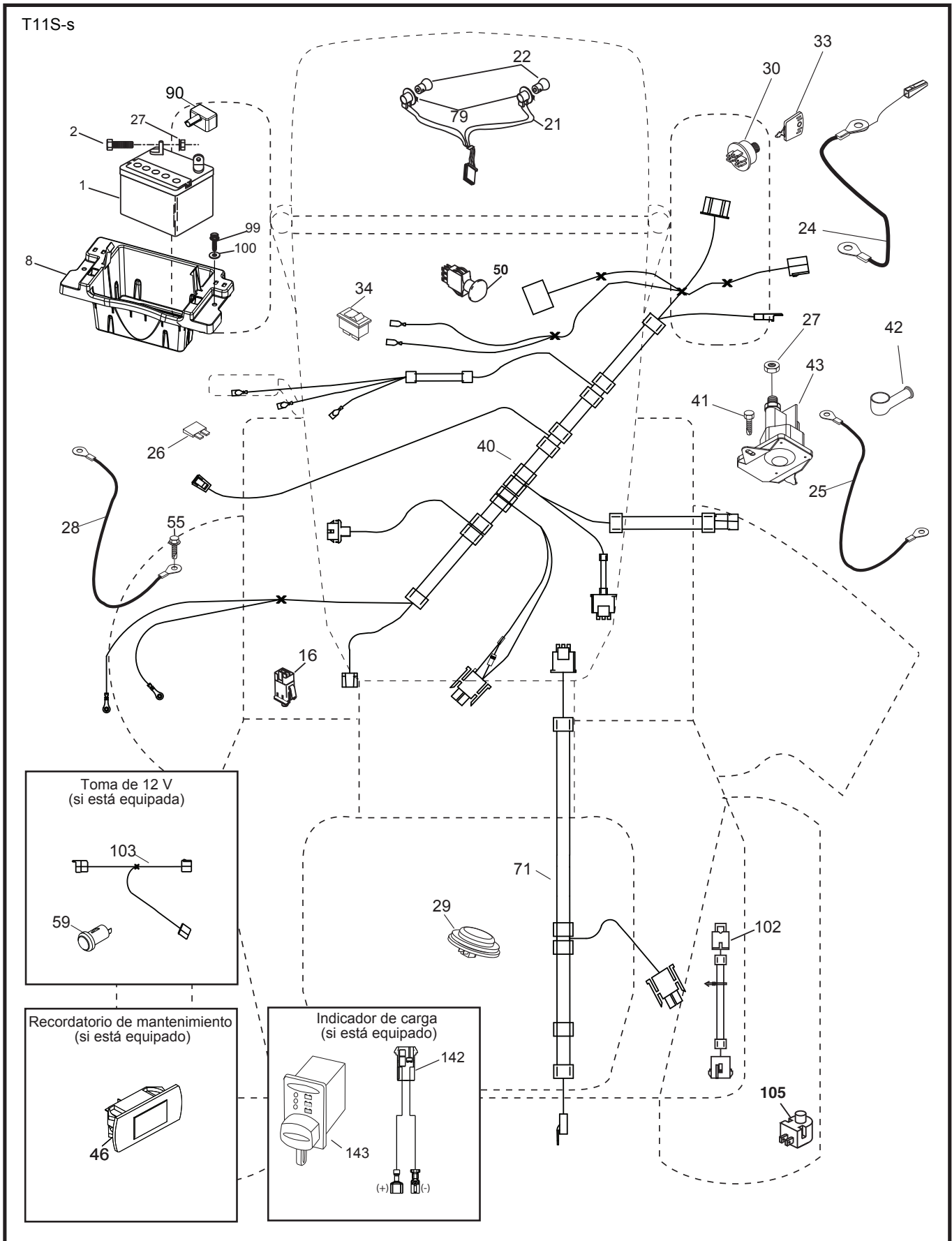

TRACTOR - MODELO NO. YTH24V54 (96045006900), PRODUCT NO. 960 45 00-69
DIAGRAMA ELÉCTRICO

CÓDIGO No.	PIEZA No.	DESCRIPCIÓN
1	532 16 34-65	Batería
2	874 76 04-12	Perno de cabeza hexagonal de 1/4-20 x 3/4
8	532 41 41-26	Puerta de la caja de la batería
16	532 17 61-38	Interruptor corta corriente a presión
21	532 40 02-52	Cableado del enchufe para la luz
22	532 00 41-52	Bombilla de luz #1156
24	585 55 56-01	Cable
25	585 55 55-01	Cable de Arrancador
26	532 17 51-58	Fusible
27	596 13 36-01	Tuerca de presión de 1/4-20
28	532 41 65-88	Cable a tierra 21" negro Calibre 6
29	532 40 15-45	Interruptor del asiento
30	532 19 33-50	Interruptor de encendido
33	532 41 19-33	Llave/cadena
34	532 11 07-12	Interruptor de luz/de restauración
40	501 13 29-01	Cableado del tablero de encendido
41	817 72 04-08	Tornillo 1/4-20 x 1/2
42	532 13 15-63	Cubierta de la terminal, rojo
43	582 04 28-02	Solenoides con émbolo de latón
46	594 91 91-01	Cuenta-horas, Delta
50	582 10 76-02	Interruptor PTO
55	817 06 05-12	Tornillo 5/16-18 x 3/4
71	532 19 42-76	Cableado del tablero
79	532 17 52-42	Enchufe de cierre por torsión del ensamble de la bombilla
90	532 43 53-95	Tapa de los bornes de la batería
99	817 67 04-12	Tornillo 1/4-20 x 3/4
100	596 13 53-01	Arandela de 9/32 x 7/8
102	532 40 44-54	Cableado
105	532 40 75-68	Interruptor para retroceder TT control del pedal

NOTA: Las dimensiones de todos los componentes están expresadas en pulgadas americanas. 1 pulgada = 25,4 mm

TRACTOR - MODELO NO. YTH24V54 (96045006900), PRODUCT NO. 960 45 00-69
CHASIS

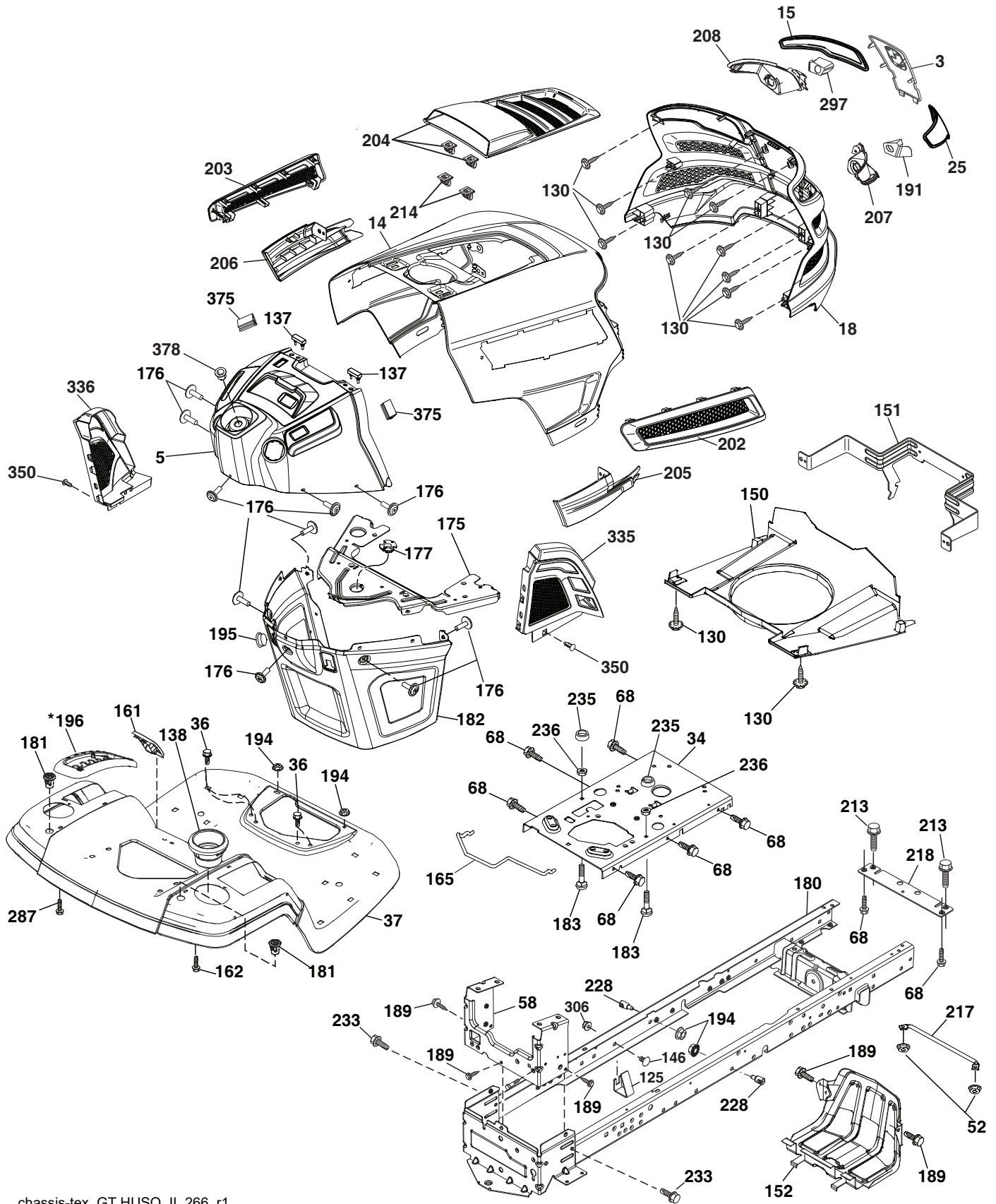

chassis-tex_GT HUSQ_II_266_r1

TRACTOR - MODELO NO. YTH24V54 (96045006900), PRODUCT NO. 960 45 00-69

CHASIS

CÓDIGO No.	PIEZA No.	DESCRIPCIÓN	CÓDIGO No.	PIEZA No.	DESCRIPCIÓN
3	532 44 44-81	Logo	195	532 40 41-37	Tapón
5	590 74 88-21	Tablero	*196	532 43 96-47	Ensamble de la consola de la plataforma de elevación
14	532 44 11-77	Capota			
15	532 43 97-33	Lente izquierdo de la parrilla	*196	596 86 92-01	Ensamble de la consola de la plataforma de elevación
18	587 52 34-01	Parrilla			
25	532 44 33-85	Lente derecho de la parrilla	202	532 43 97-28	Salida de Ventilación (LD)
34	580 91 08-01	Chapa Motor	203	532 43 97-27	Salida de Ventilación (LI)
36	817 06 05-12	Tornillo de 5/16-18 x 3/4	204	587 48 58-01	Salida de Ventilación superior
37	532 44 12-69	Guardabarros	205	532 43 97-30	Camisa de Capota (LD)
52	596 04 05-01	Tuerca de presión de 5/16-18 x .18	206	532 43 97-29	Camisa de Capota (LI)
58	532 41 22-80	Barra de tracción	207	587 46 48-01	Bisel derecho (LD)
68	596 03 07-01	Tornillo de 5/16-18 x 1/2	208	587 46 45-01	Bisel izquierdo (LI)
125	581 68 48-01	Cierre	213	596 03 05-01	Perno de 5/16-18 unc x 3/4
130	596 32 17-01	Tornillo de #10 x 0.750	214	532 19 91-45	Cierre
137	532 40 75-90	Cubierta Tablero	217	532 40 91-67	Varilla giratoria
138	532 43 97-47	Portavasos	218	532 19 63-95	Tope
146	581 85 79-01	Perno 3/8-16 x 5/8	228	593 82 40-01	Perno prisionero con anti rotación
150	532 43 97-74	Cubierta térmica del conducto	233	532 19 65-39	Tornillo
151	532 43 66-70	Soporte pivotante	235	596 56 42-01	Separador del guardabarros
152	532 43 98-70	Protector contra oscurecimiento	236	873 93 05-00	Tuerca de presión 5/16-18 unc
161	532 43 97-81	Ventana de combustible	287	817 60 04-06	Tornillo 1/4 - 20 x 3/8
162	596 13 41-01	Tornillo de 1/4-15 x 1/2	297	532 43 74-56	Parrilla reflectora LI
165	532 19 68-26	Apoyo de tanque	306	873 90 06-00	Tuerca de presión 3/8-18 unc
175	590 60 77-02	Travesaño	335	532 44 82-04	Cubierta LD
176	532 40 07-76	Tornillo 10-24 x 5/8	336	532 44 53-09	Cubierta LI
177	532 19 52-28	Buje de dirección	350	532 44 51-43	Cierre del árbol de navidad
180	532 41 50-63	Chasis	375	586 90 82-01	Cubierta Capota
181	532 43 97-46	Buje			
182	532 40 68-59	Tablero inferior			
183	595 30 57-01	Tornillo de 5/16-18 x 1-1/4			
189	817 00 05-12	Tornillo 3/8-16 x 3/4			
191	532 43 74-55	Parrilla reflectora LD			
194	596 13 57-01	Tuerca de presión de 5/16-18 x .68			

NOTA: Las dimensiones de todos los componentes están expresadas en pulgadas americanas. 1 pulgada = 25,4 mm

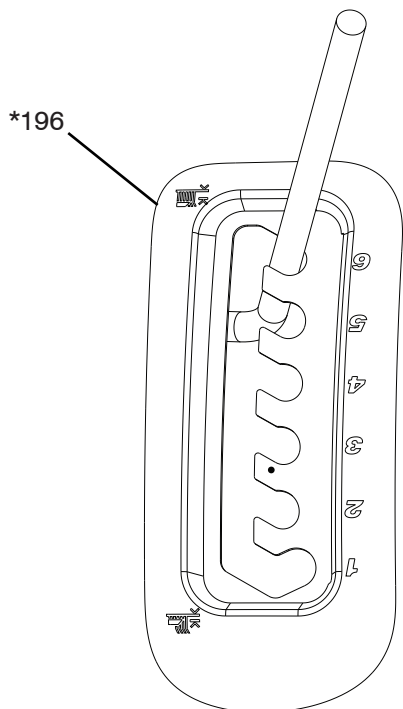

*196 532 43 96-47 Ensamble de la consola de la plataforma de elevación

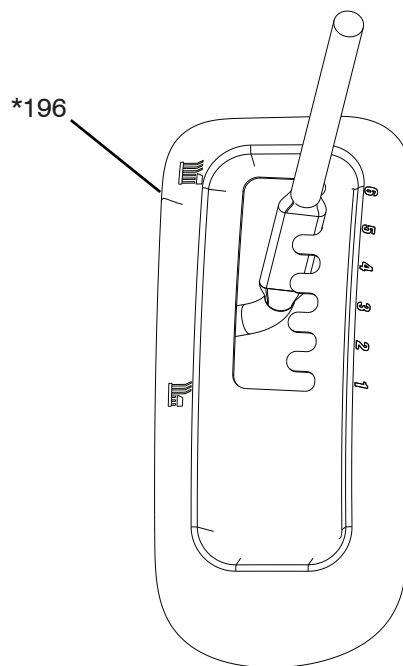

*196 596 86 92-01 Ensamble de la consola de la plataforma de elevación

TRACTOR - MODELO NO. YTH24V54 (96045006900), PRODUCT NO. 960 45 00-69

TRANSMISIÓN

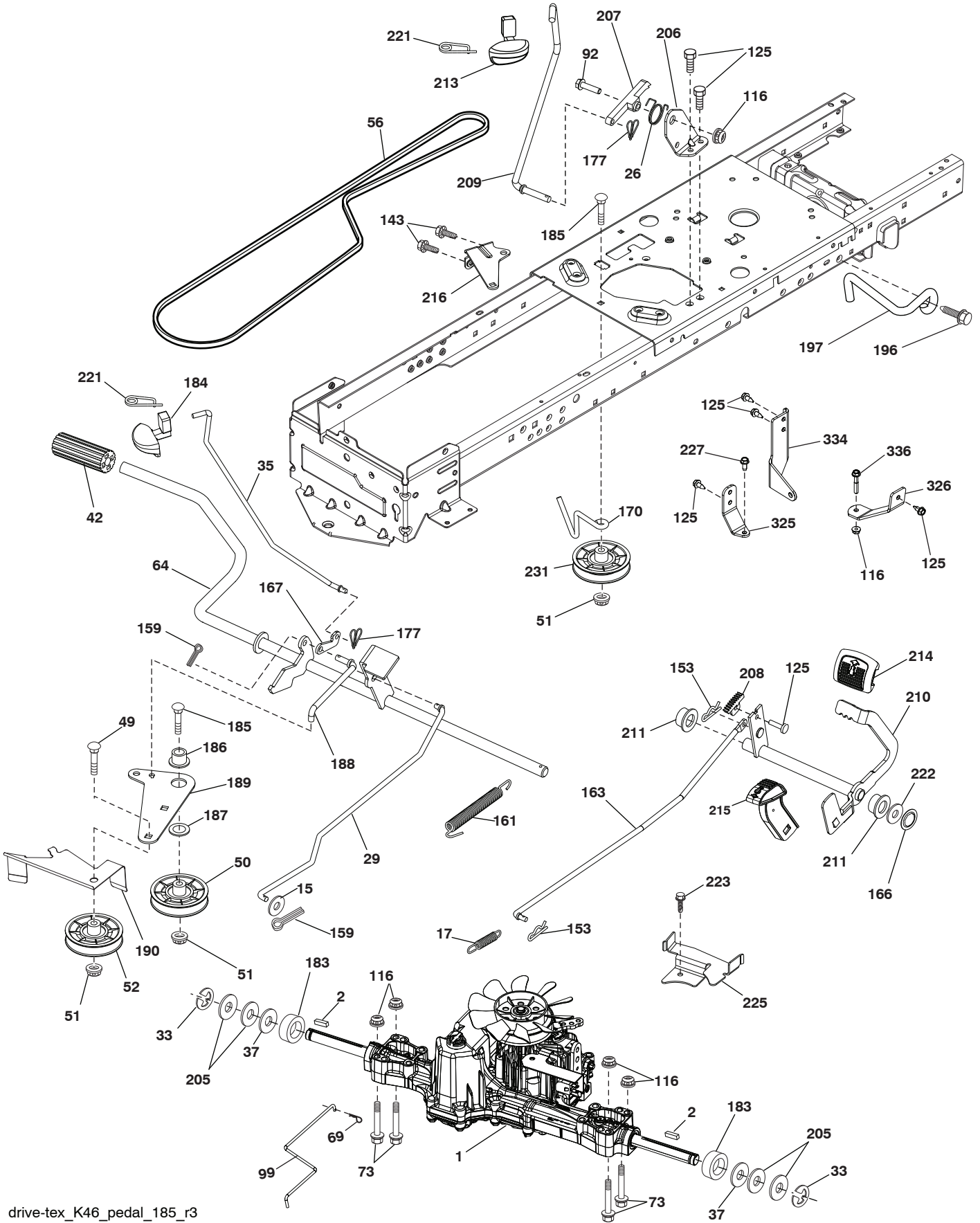

drive-tex_K46_pedal_185_r3

TRACTOR - MODELO NO. YTH24V54 (96045006900), PRODUCT NO. 960 45 00-69
TRANSMISIÓN

CÓDIGO No.	PIEZA No.	DESCRIPCIÓN	CÓDIGO No.	PIEZA No.	DESCRIPCIÓN
1	---	Transeje, TUFFTORQ K46BT (426120) (Haga el pedido de las piezas al fabricante del transeje.)	186	532 19 43-21	Espaciador de retención
			187	596 13 55-01	Arandela de 13/32 x 2
			188	582 21 70-01	Mecanismo de desplazamiento de la varilla de mando del embrague del largo
2	532 12 35-83	Cuña			
15	596 56 53-01	Arandela de 3/8 x 0.08			
17	532 41 36-78	Resorte de freno	189	532 19 43-17	Palanca acodada del mecanismo de desplazamiento
26	532 19 96-79	Crucero con retorno de muelle			
29	532 40 38-06	Varilla del freno	190	532 19 43-18	Sujetador de la palanca acodada del mecanismo de desplazamiento
33	812 00 00-01	Aro E			
35	590 60 59-02	Varilla del freno de mano	196	817 00 06-16	Tornillo 3/8-16 x 1
37	532 18 89-67	Arandela	197	585 65 86-02	Soporte antirrotación
42	532 00 88-83	Cubierta del pedal	205	532 12 17-48	Arandela de 25/32 x 1-5/8 calibre 16
49	596 13 62-01	Perno de 3/8-16 x 3/4	206	532 44 85-96	Soporte de montaje del bloqueo del crucero
50	532 19 43-27	Polea loca plana			
51	873 90 06-00	Tuerca de presión de 3/8-16	207	587 03 14-02	Pestillo
52	532 19 43-26	Polea loca con ranura en V con un desplazamiento	208	596 56 41-01	Engranaje
			209	590 52 78-02	Varilla de control del crucero
56	592 85 52-01	Correa trapezoidal de la transmisión	210	532 40 09-80	Ensamble del control del pedal
64	532 19 78-65	Ensamble del eje Control del pedal de freno	211	532 12 01-83	Rodamiento de nylon
			213	532 40 31-19	Perilla de control del crucero
69	532 42 33-03	Zinc suave horquilla .059 x 1.125	214	532 42 12-63	Forro del pedal para avanzar
73	596 13 65-01	Perno de 5/16-18 x 1-1/2	215	586 60 65-02	Forro del pedal para retroceder
92	595 30 57-01	Tornillo de 5/16-18 x 1-1/4	216	532 19 61-31	Soporte del Polea
99	582 40 45-01	Varilla de Derivación LT K46, K57	221	532 40 31-87	Abrazadera de retención del resorte de la manija
116	596 13 57-01	Tuerca de 5/16-18 x .68			
125	817 00 05-12	Tornillo de 5/16-18 x 3/4	222	879 21 20-10	Arandela de 21/32 x 1-1/4 calibre 10
143	596 03 07-01	Tornillo de 5/16-18 x 1/2	223	598 66 26-01	Perno de T45. 5/16-18X.75
153	532 00 44-97	Retén del resorte	225	532 40 33-19	Sujetador de la correa
159	596 02 95-01	Goupille Fendue 1/8 Dia. x 3/4	227	596 13 59-01	Perno de 5/16-18 x 3/4
161	532 10 57-09	Resorte de retorno del embrague	231	532 40 72-87	Polea loca con ranura
163	593 86 10-01	Tige, K46/K57R	325	586 00 11-02	Soporte de torsión (LD)
166	532 42 91-64	Tuerca de presión	326	586 43 12-02	Correa de torsión (LI)
167	532 40 52-57	Pestillo del freno de mano	334	585 88 22-02	Soporte
170	532 41 34-30	Sujetador de la correa central	336	596 13 57-01	Tuerca de presión de 5/16-18 x .68
177	587 22 53-01	Abrazadera de retención 1 In.			
183	532 13 70-57	Separador del eje			
184	587 65 37-01	Manija del freno de mano			
185	872 11 06-22	Perno			

NOTA: Las dimensiones de todos los componentes están expresadas en pulgadas americanas. 1 pulgada = 25,4 mm

**TRACTOR - MODELO NO. YTH24V54 (96045006900), PRODUCT NO. 960 45 00-69
MOTOR**

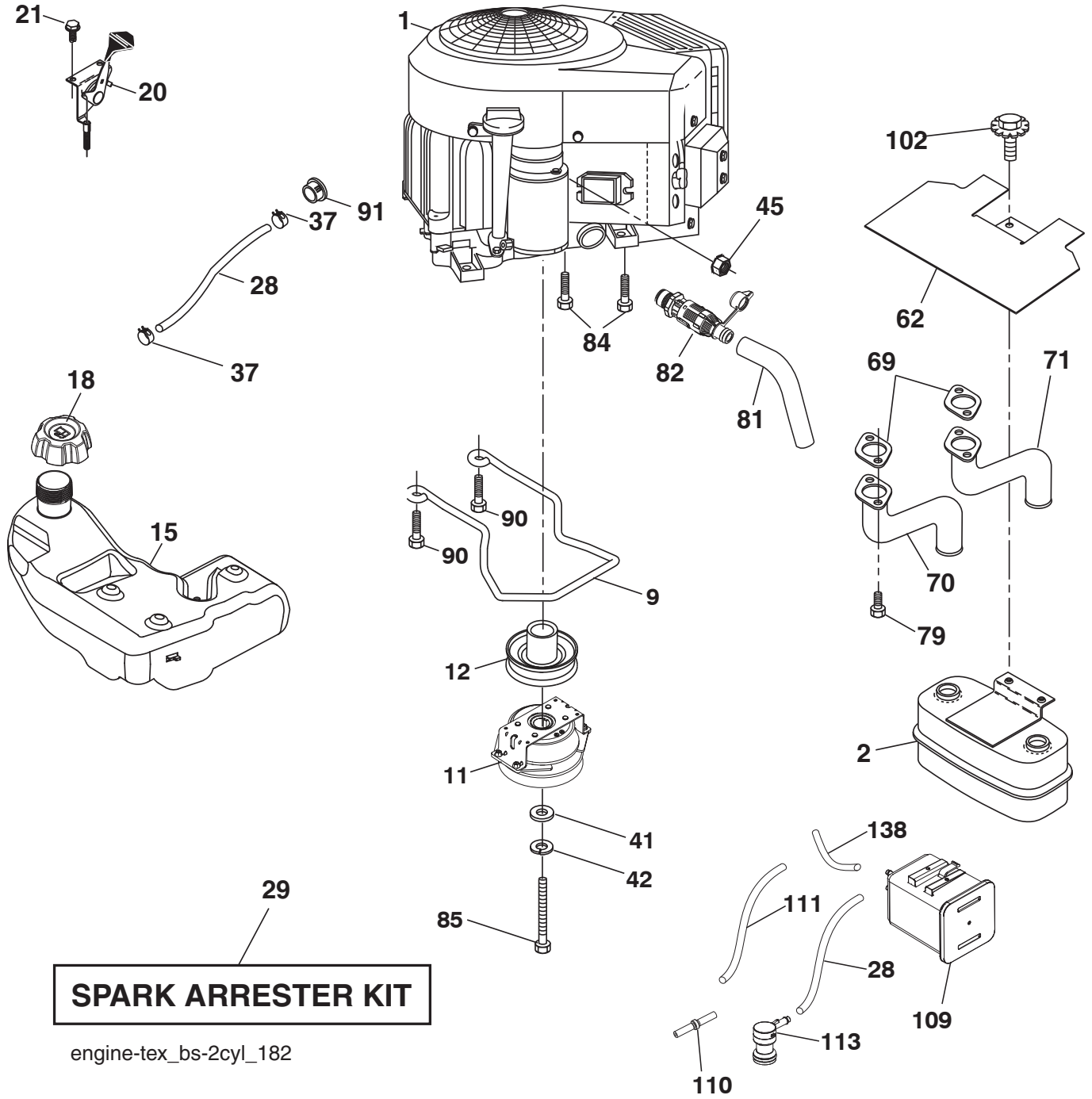

**TRACTOR - MODELO NO. YTH24V54 (96045006900), PRODUCT NO. 960 45 00-69
MOTOR**

CÓDIGO No.	PIEZA No.	DESCRIPCIÓN
1	- - - - -	Motor Briggs modelo No. 44N877-0003-G1 (501259701) (Haga el pedido de las piezas al fabricante del motor.)
2	589 81 87-01	Silenciador
9	501 83 26-02	Ensamble del sujetador de la correa del motor
11	587 24 16-01	Embrague de eléctrico
12	532 40 50-97	Polea del motor
15	599 83 76-01	Depósito de combustible 3 galón
18	599 50 22-01	Ensamble de la tapa 3"
20	587 24 25-01	Control del regulador
21	596 32 17-01	Tornillo de #10 x 0.750
28	532 40 11-35	Línea de combustible
29	532 13 71-80	Equipo apagachispas
37	532 12 34-87	Abrazadera de la manguera
41	532 12 61-97	Arandela 1-1/2 OD x 15/32 ID x .250
42	596 23 89-01	Arandela de 7/16"
45	596 13 36-01	Tuerca de presión de 1/4-20
62	532 43 40-17	Silenciador con pantalla térmica
69	532 16 53-91	Junta
70	581 88 11-01	Tubo de escape(L.I.)
71	581 88 10-01	Tubo de escape (L.D.)
79	596 13 42-02	Tornillo de 5/16-18 x 1
81	532 14 84-56	Tubo de fácil drenaje de aceite
82	532 42 82-87	Aceite drenaje válvula
84	817 06 06-20	Tornillo 3/8-16 x 1-1/4
85	501 60 66-01	Perno 7/16-20 x 3.75 calibre 5
90	817 00 06-16	Tornillo 3/8-16 x 1
91	532 18 74-95	Buje
102	817 00 05-12	Tornillo 5/16-18 x 3/4
109	532 41 41-14	Bote
110	532 41 41-18	Válvula
111	596 94 15-01	Línea de purga .1875"
113	532 41 41-27	Válvula
138	532 42 07-18	Línea de purge

NOTA: Las dimensiones de todos los componentes están expresadas en pulgadas americanas. 1 pulgada = 25,4 mm

Para el servicio de motor y repuestos, llame el número de llamada gratuita para su fabricante de motor listó abajo:

Briggs & Stratton 1-800-233-3723

Información de Clasificación de Potencia del Motor

La clasificación de potencia para un modelo de motor a gas en particular se designa de acuerdo al código J1940 de SAE (Sociedad de Ingenieros Automotrices) (Procedimiento de Clasificación de Potencia & Torque del Motor Pequeño), y la clasificación de desempeño ha sido obtenida y corregida de acuerdo con el código J1995 de SAE (Revisión 2002-05). Los valores de torque se obtienen a 3060 RPM; los valores de potencia se obtienen a 3600 RPM. La potencia bruta actual del motor será inferior y está afectada, entre otras cosas, por las condiciones ambientales operativas y la variabilidad de motor a motor. Dado ambos un amplio conjunto de productos en los cuales son puestos nuestros motores, y la variedad de emisiones ambientales aplicables al operar el equipo, el motor a gas no desarrollará la potencia nominal cuando sea usado en una parte del equipo acoplado (potencia real "en el-sitio" o potencia neta). Esta diferencia se debe a una variedad de factores que incluyen, pero que no están limitados a, accesorios (filtro de aire, sistema de escape, sistema de carga, sistema de enfriamiento, carburador, bomba de combustible, etc.) limitaciones de la aplicación, condiciones ambientales de operación (temperatura, humedad, altitud), y la variabilidad de motor a motor. Debido a las limitaciones, Briggs & Stratton puede sustituir este motor con clasificación de potencia más alta por esta serie de motor.

TRACTOR - MODELO NO. YTH24V54 (96045006900), PRODUCT NO. 960 45 00-69
ENSAMBLE DE LA DIRECCIÓN

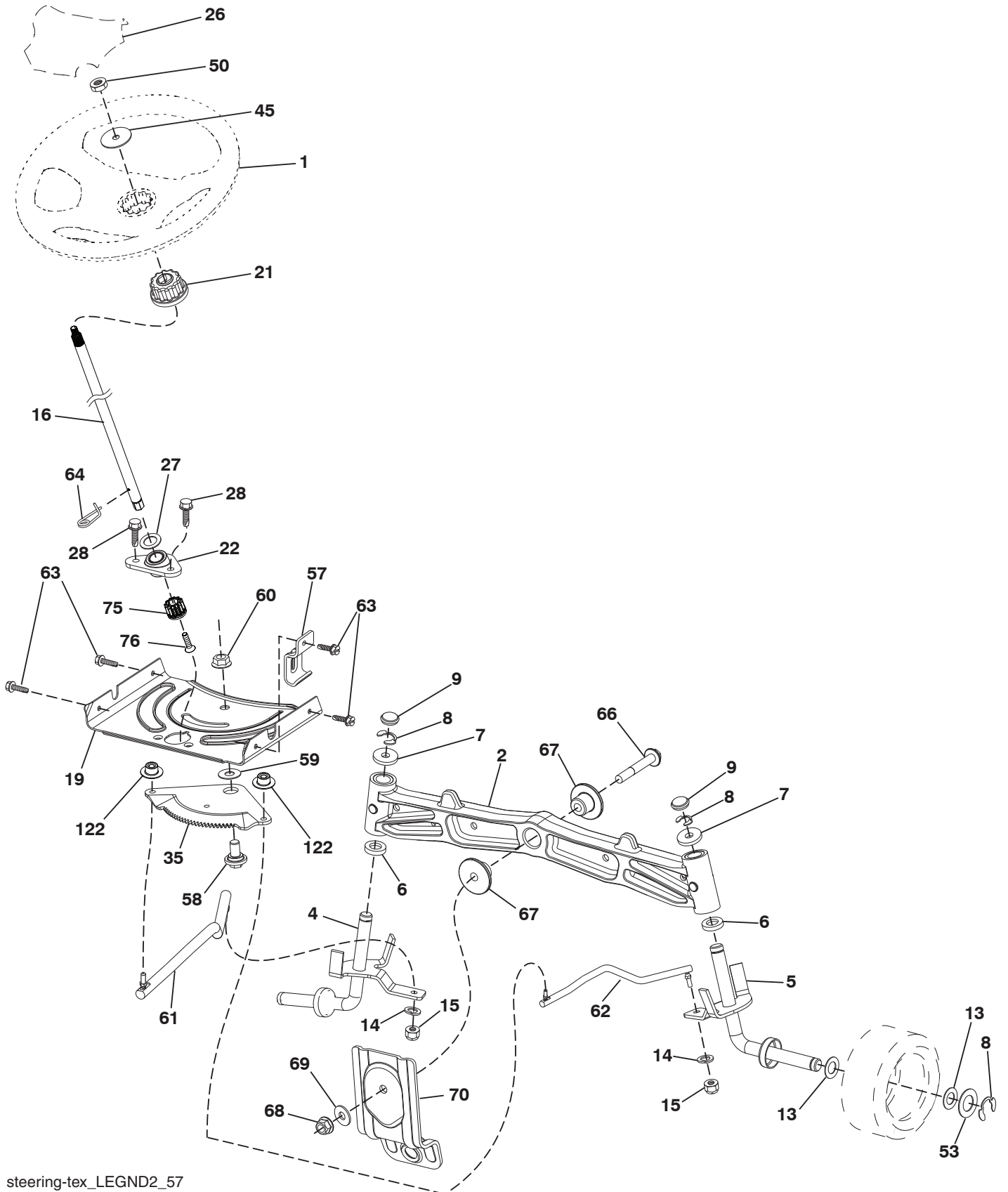

steering-tex_LEGND2_57

TRACTOR - MODELO NO. YTH24V54 (96045006900), PRODUCT NO. 960 45 00-69
ENSAMBLE DE LA DIRECCIÓN

CÓDIGO No.	PIEZA No.	DESCRIPCIÓN
1	532 43 97-40	Volante de dirección
2	532 19 59-68	Eje delantero
4	532 40 30-87	Ensamble del husillo izquierdo
5	532 40 30-88	Ensamble del husillo derecho
6	532 00 62-66	Arandela de .75 x 1.230
7	532 12 17-48	Arandela 25/32 x 1-5/8 x Calibre 16
8	812 00 00-29	Abrazadera del aro No. T5304-75
9	532 12 12-32	Tapa del husillo
13	532 12 17-49	Arandela 25/32 x 1-1/4 x Calibre 16
14	596 23 87-01	Arandela de .381 x .680
15	873 54 06-00	Tuerca corona de presión de 3/8-24 unf
16	587 01 60-02	Eje de dirección
19	532 19 47-29	Placa de dirección
21	586 84 02-01	Adaptador del volante de dirección
22	585 02 98-02	Rodamiento
26	532 43 97-43	Inserto del volante de dirección
27	596 93 34-01	Arandela
28	817 00 06-12	Tornillo 3/8-16 x 3/4
35	532 19 47-32	Engranaje del sector de la placa
45	587 01 64-01	Arandela 3/8 ID 2-3/8 OD calibre 12 PLTD
50	873 90 06-00	Tuerca 3/8-16 unc
53	532 18 89-67	Arandela .793 x 1.637 x .060
57	532 19 72-46	Tope superior del soporte
58	532 19 47-47	Perno de tope del sector del pivote CFM
59	532 19 47-48	Arandela de empuje del sector de dirección
60	873 97 10-00	Tuerca de presión con brida de 5/8-11
61	532 19 47-40	Barra de acoplamiento izquierda
62	532 19 47-41	Barra de acoplamiento derecha
63	817 00 05-12	Tornillo 5/16-18 x 3/4
64	532 19 98-49	Abrazadera de retención del resorte de la dirección
66	871 02 07-48	Perno de cabeza 7/16-14 x 3
67	532 19 47-37	Buje PM del eje delantero
68	873 90 07-00	Tuerca de presión con brida de 7/16-14 grado 5
69	532 19 91-62	Arandela 1.5 x .505 x .118
70	585 33 88-01	Soporte de la plataforma delantera
75	580 68 37-01	Piñón
76	580 68 36-01	Tornillo
122	532 44 49-62	Tapa

NOTA: Las dimensiones de todos los componentes están expresadas en pulgadas americanas. 1 pulgada = 25,4 mm

TRACTOR - MODELO NO. YTH24V54 (96045006900), PRODUCT NO. 960 45 00-69
PLATAFORMA DE LA CORTADORA DE CÉSPED

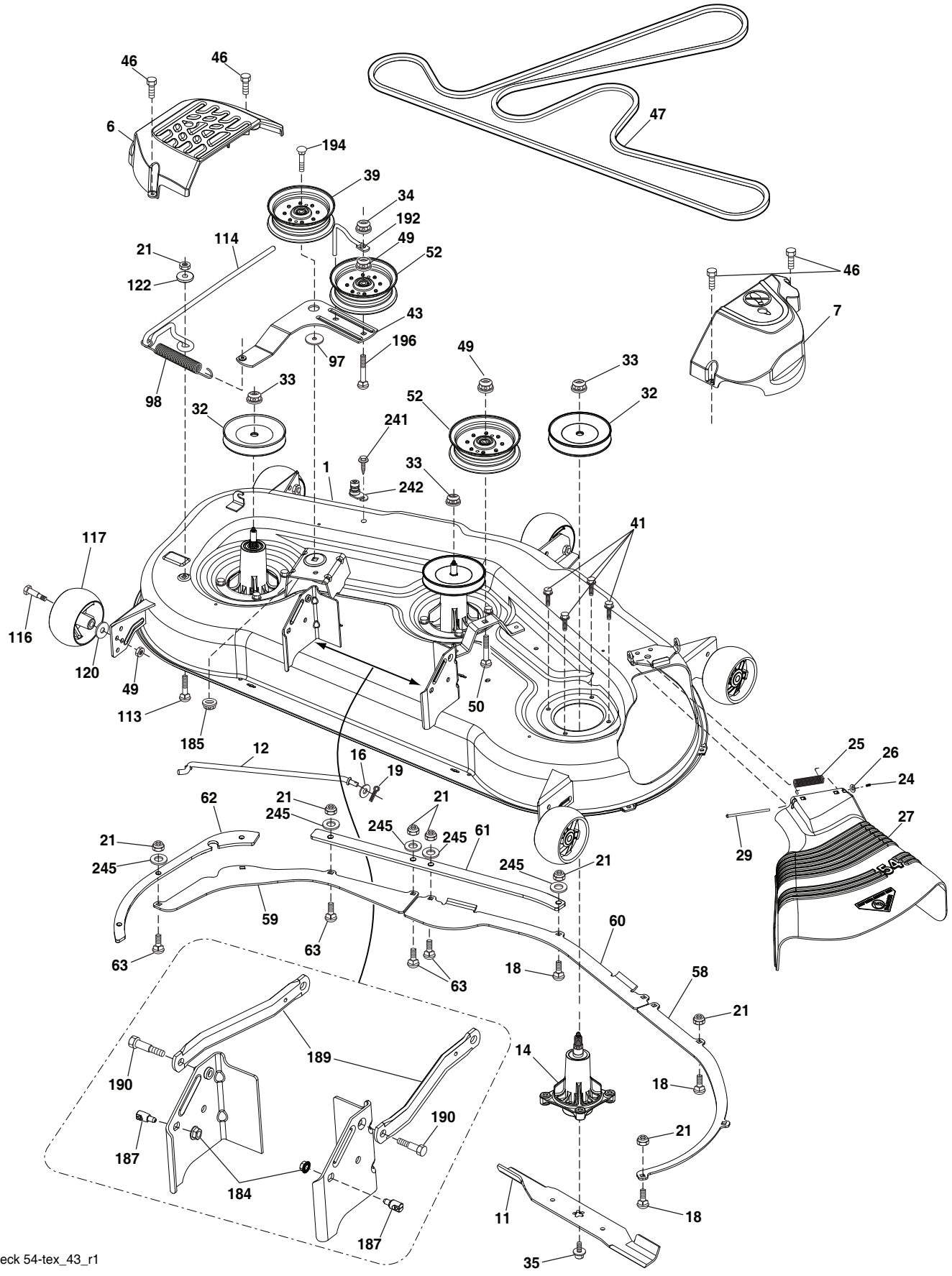

mower_deck 54-tex_43_r1

TRACTOR - MODELO NO. YTH24V54 (96045006900), PRODUCT NO. 960 45 00-69
PLATAFORMA DE LA CORTADORA DE CÉSPED

CÓDIGO NO.	PIEZA NO.	DESCRIPCIÓN	CÓDIGO NO.	PIEZA NO.	DESCRIPCIÓN
1	532 41 82-30	Carcasa de la cortadora de césped	61	585 32 26-05	Placa
6	532 19 60-66	Cubierta derecha del mandril	62	585 32 28-05	Placa
7	532 19 71-81	Cubierta izquierda del mandril	63	872 11 05-10	Perno 5/16-18 x 1-1/4 grado 5
11	532 18 72-56	Cuchilla de la cortadora de césped	97	532 17 85-15	Perno
12	532 40 48-51	Barra	98	532 19 61-05	Resorte
14	587 82 03-01	Conjunto del mandril (incluye mandril y tornillos)	113	596 43 57-01	Perno de 5/16-18 x 1.02 Gr. 5
16	596 13 32-01	Arandela de 13/32 x 13/16 x 12	114	532 18 75-56	Barra
18	596 13 64-01	Perno de 5/16-18 x 5/8	116	596 43 44-04	Perno de 3/8-16 x 3-5/8"
19	532 19 42-08	Alfiler	117	589 52 73-01	Calibrador de la rueda
21	596 04 05-01	Tuerca de presión de 5/16-18	120	596 13 49-01	Arandela de 3/8 x 7/8
24	532 10 53-04	Tapa de la manga	122	532 18 75-57	Buje
25	532 17 81-02	Resorte de torsión del deflector	184	596 13 57-01	Tuerca de presión de 5/16-18 x .68
26	532 11 04-52	Tuerca de presión	185	873 90 07-00	Tuerca de presión 7/16-14 grado 5
27	532 18 89-38	Protector del deflector	187	593 82 40-01	Perno prisionero con anti rotación
29	595 29 70-01	Varilla de la bisagra	189	587 14 05-02	Barra
32	532 15 35-35	Polea del mandril	190	532 19 65-39	Perno de tope
33	596 13 48-01	Tuerca de 9/16-18 x 1.010	192	532 19 84-68	Sujetador de la correa
34	596 32 26-01	Tuerca de 3/8 - 16 unc	194	874 49 07-36	Perno
35	584 30 93-01	Tornillo 7/16-20 x 1	196	596 33 78-01	Perno de 3/8-16 x 2-1/2
39	532 19 73-80	Polea loca	241	532 15 29-27	Tornillo
41	584 95 39-01	Perno 313-18 x 1.19	242	532 41 55-98	Puerto de lavado de la cubierta
43	532 19 60-65	Brazo de la polea	245	596 20 41-01	Arandela de 11/32 x 11/16 x 14
46	532 13 77-29	Espaciador de retención	--	532 41 64-05	Acoplador
47	587 68 67-01	Tornillo hexagonal con arandela de 3/8-16 x 1	--	532 41 82-29	Reemplazo de la cortadora de césped, completa
49	873 90 06-00	Dispositivo de protección de la polea			
50	596 13 63-01	Perno de 3/8-16 x 2			
52	532 19 73-79	Brazo del freno de la cortadora de césped			
58	532 18 73-42	Varillaje del freno			
59	532 18 73-44	Manija del cable de embrague			
60	532 18 76-07	Correa trapezoidal			

NOTA: Las dimensiones de todos los componentes están expresadas en pulgadas americanas.
 1 pulgada = 25,4 mm

TRACTOR - MODELO NO. YTH24V54 (96045006900), PRODUCT NO. 960 45 00-69
ELEVACIÓN DE LA CORTADORA DE CÉSPED

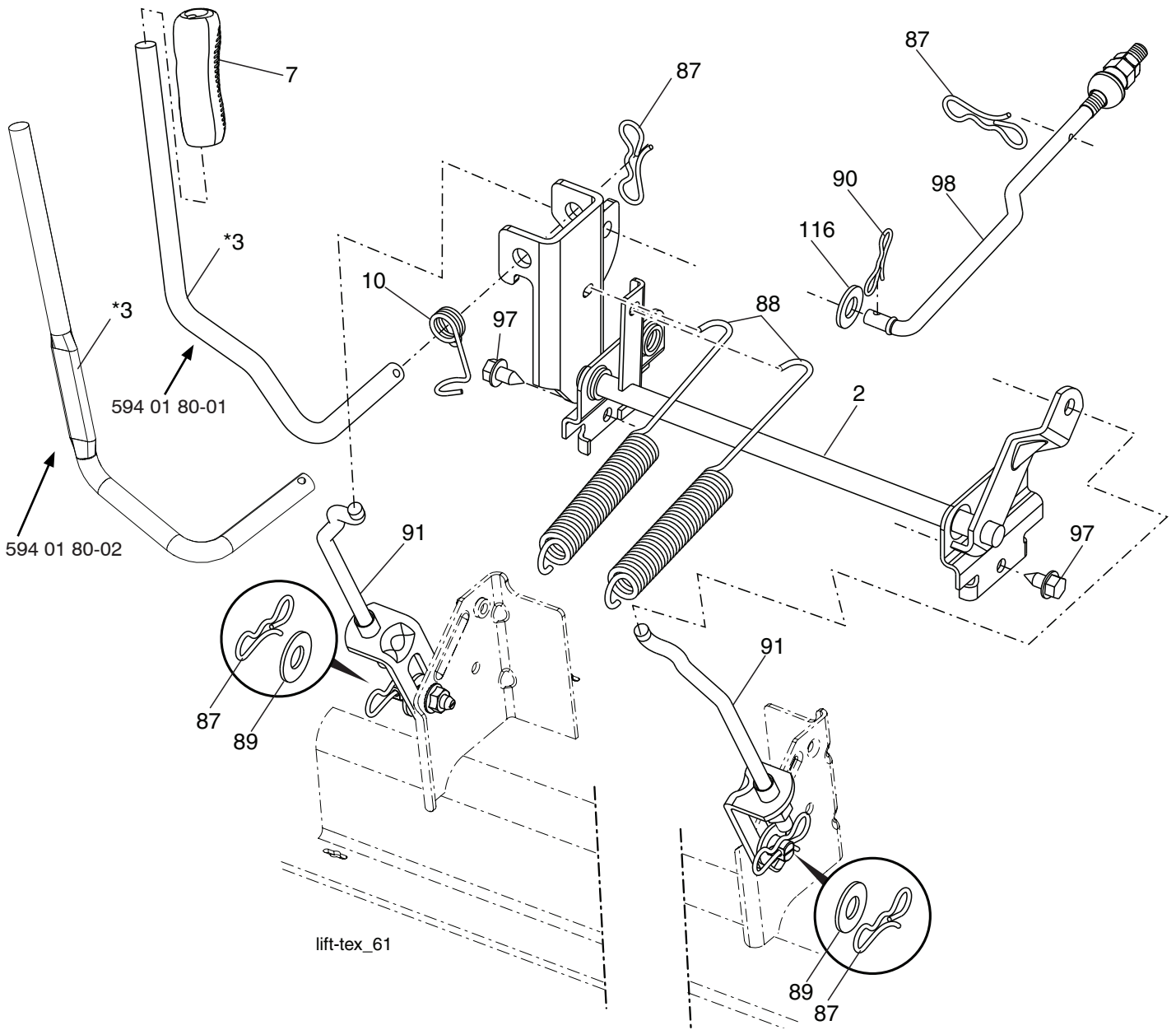

CÓDIGO No.	PIEZA No.	DESCRIPCIÓN
2	532 42 20-27	Ensamble del eje de la elevación
*3	594 01 80-01	Ensamble de la palanca de elevación
*3	594 01 80-02	Palanca de elevación de estrecho
7	580 96 23-01	Mango de la palanca
10	532 19 63-14	Resorte de torsión
87	532 19 42-09	Pasador de chaveta de 7/16 con bloqueo en forma de mariposa
88	532 41 07-10	Resorte de ayuda de la elevación
89	819 19 19-12	Arandela de zinc transparente
90	532 19 42-08	Pasador de chaveta de 5/16 con bloqueo en forma de mariposa

CÓDIGO No.	PIEZA No.	DESCRIPCIÓN
91	589 46 48-05	Ensamble del acoplamiento Elevación trasera
97	817 00 06-12	Tornillo de 3/8-16 x 0,75
98	581 50 69-02	Ensamble del acoplamiento Elevación Frente
116	594 97 65-01	Arandela 15/32 x 15/16 x .065

NOTA: Las dimensiones de todos los componentes están expresadas en pulgadas americanas. 1 pulgada = 25,4 mm

TRACTOR - MODELO NO. YTH24V54 (96045006900), PRODUCT NO. 960 45 00-69
ENSAMBLE DEL ASIENTO

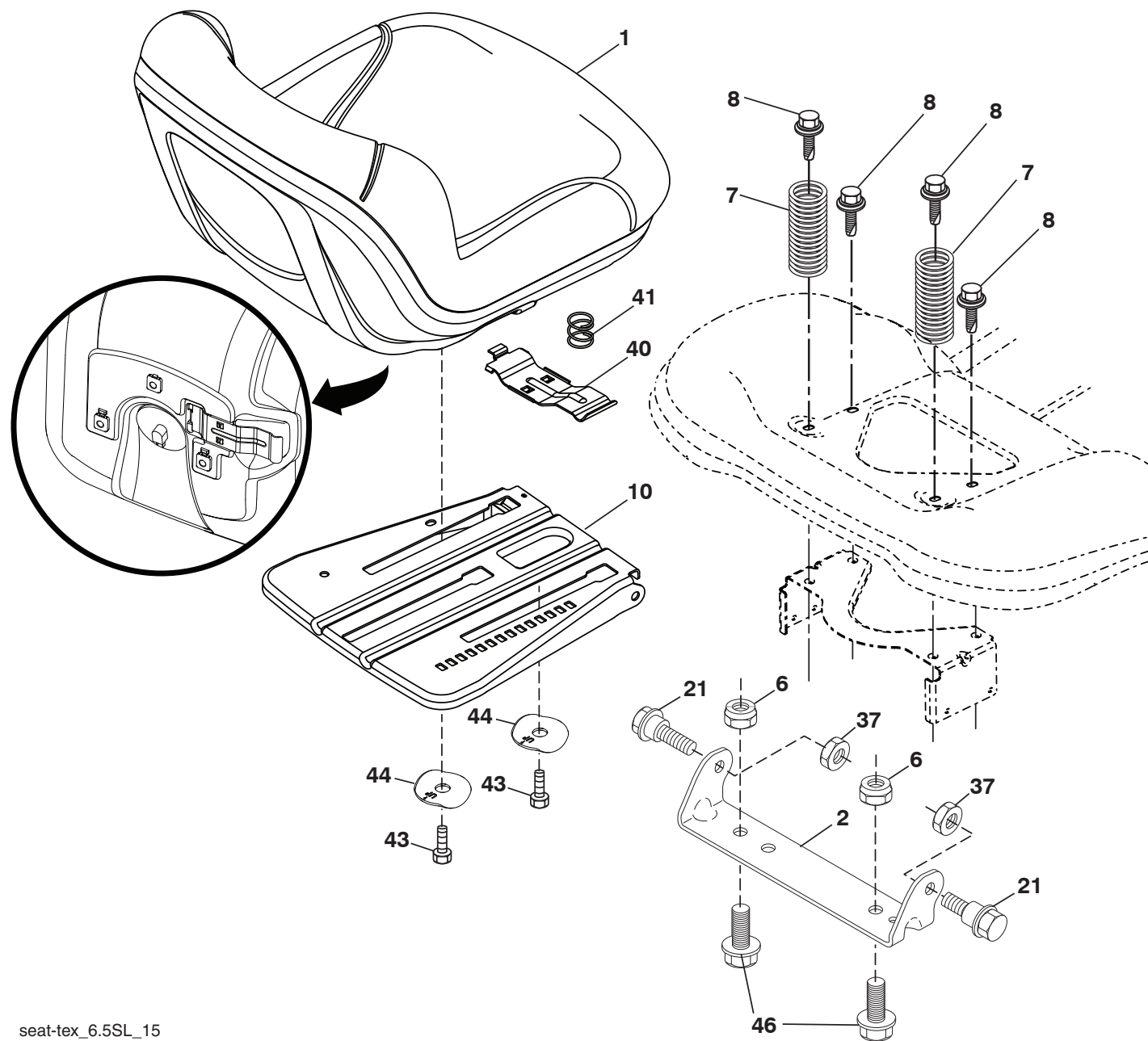

seat-tex_6.5SL_15

CÓDIGO No.	PIEZA No.	DESCRIPCIÓN
1	532 43 98-22	Asiento
2	532 18 01-66	Soporte pivotante del guardabarros
6	873 80 06-00	Tuerca de presión c/aislamiento de 3/8-16 unc
7	589 48 35-01	Resorte del asiento
8	532 17 18-77	Perno de 5/16" unc x 3/4"
10	596 65 74-02	Chapa del Asiento
21	587 90 78-01	Perno de tope de 5/16-18 x 5/8
37	596 58 37-02	Tuerca 5/16-18
40	595 08 81-02	Manija para deslizar el asiento x 431

CÓDIGO No.	PIEZA No.	DESCRIPCIÓN
41	532 19 82-00	Resorte para trabar el asiento
43	874 76 06-12	Perno de cabeza hexagonal con aleta de 3/8-16 unc x 3/4
44	501 0518-01	Arandela de con alas 3/8 ID 1.5 OD
46	588 09 04-01	Perno 3/8-16 x 1, 1.25

NOTA: Las dimensiones de todos los componentes están expresadas en pulgadas americanas. 1 pulgada = 25,4 mm

CALCOMANÍAS

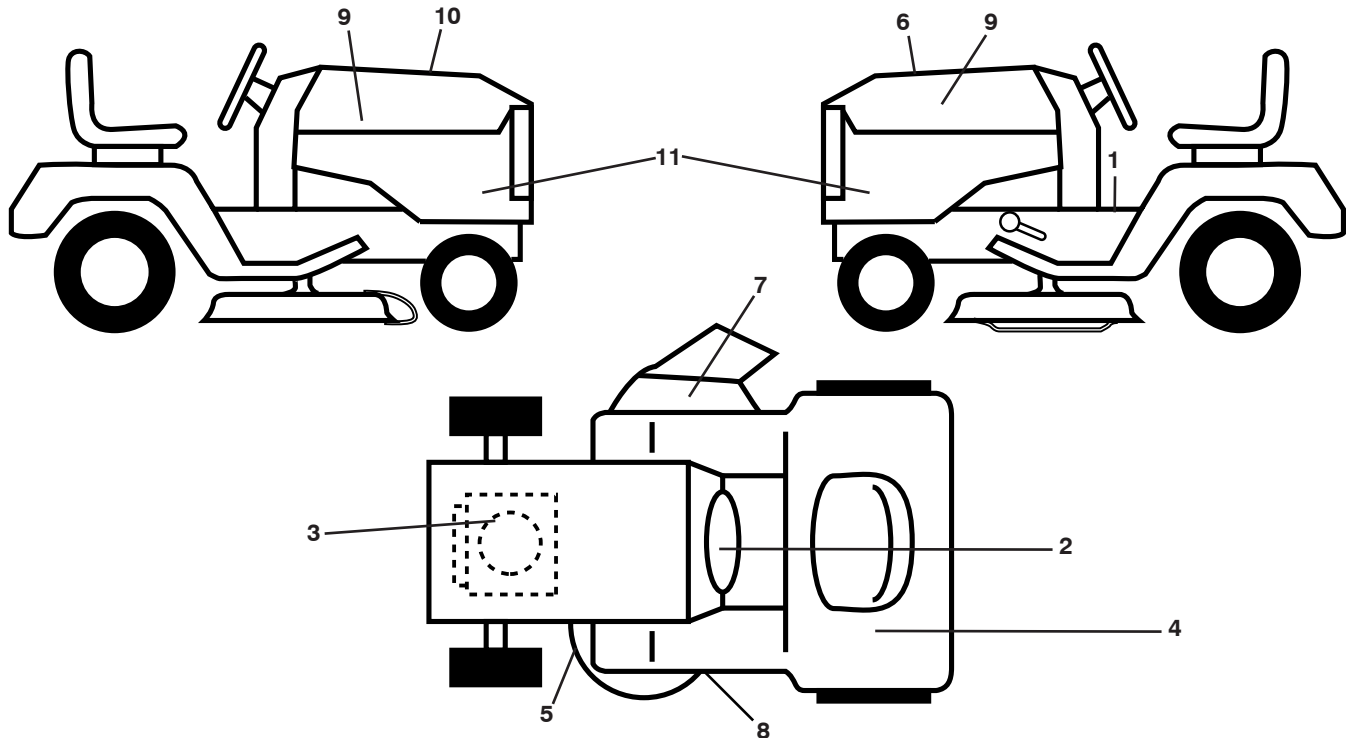

CÓDIGO No.	PIEZA No.	DESCRIPCIÓN
1	586 71 38-01	Calcomanía precaución
2	596 02 42-01	Calcomanía advertencia
3	585 93 73-01	Calcomanía H.P.
4	580 88 58-01	Calcomanía de E85 advertencia
5	581 72 45-02	Calcomanía precaución
6	591 44 63-01	Calcomanía de reemplazo
7	584 90 46-01	Calcomanía precaución
8	581 58 00-02	Calcomanía del diagrama de la cortadora de césped
9	581 62 73-01	Calcomanía para el logo de la capota
10	532 42 38-29	Calcomanía responsabilidad del cliente

CÓDIGO No.	PIEZA No.	DESCRIPCIÓN
11	586 01 34-01	Calcomanía para el panel lateral
--	581 72 48-01	Calcomanía para la desviación
--	532 43 96-81	Forro del apoyo para los pies (LI)
--	532 43 96-82	Forro del apoyo para los pies (LD)
--	115 94 43-49	Manual del operador (Inglés/Español)
--	115 94 44-49	Manual De Repuestos (Inglés/Español)
--	587 71 00-26	Guía de inicio rápido (Inglés/Español)

RUEDAS Y NEUMÁTICOS

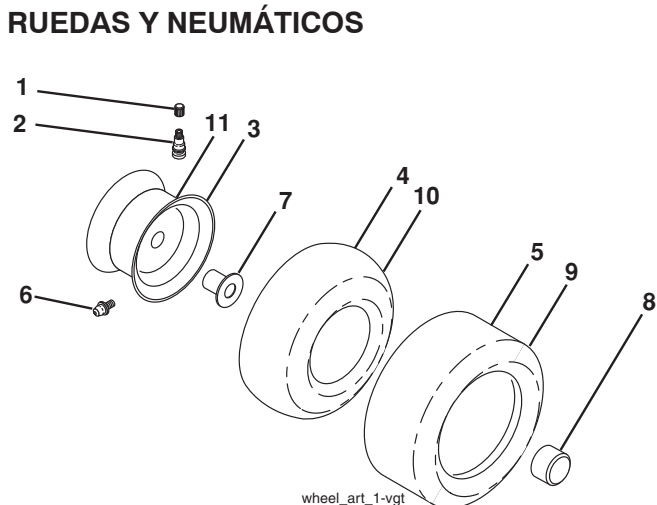

CÓDIGO No.	PIEZA No.	DESCRIPCIÓN
1	532 05 91-92	Tapa de la válvula del neumático
2	532 06 51-39	Vástago de la válvula
3	532 13 83-36	Ensamble de las llantas delanteras
4	532 05 99-04	Cámara delantera (Mantenimiento sólo)
5	532 10 62-22	Neumático delantero 15 x 6-6
6	532 00 02-78	Accesorio para engrasar (solo para la rueda delantera)
7	532 00 90-40	Rodamiento de la brida (solo para la rueda delantera)
8	532 17 50-39	Tapa del eje
9	532 13 84-68	Neumático trasero 20 x 8-8
10	532 00 71-52	Cámara trasera (Mantenimiento sólo)
11	532 13 83-37	Ensamble trasero de la llanta
--	532 14 43-34	Sellador para neumáticos (tubo de 10 onzas [283 gr])

NOTA: Las dimensiones de todos los componentes están expresadas en pulgadas americanas. 1 pulgada = 25,4 mm

SERVICE NOTES / AVISO



www.husqvarna.com