

115 86 33-26 Rev. 3



Repair Parts Manual Manual De Repuestos

GT48DXLS / 96043023100

Please read the operator's manual carefully and make sure you understand the instructions before using the machine.

Por favor lea cuidadosamente y comprenda estas intrucciones antes de usar esta maquina.



English/Spanish

HOW TO USE THIS MANUAL

This manual is designed to provide the customer with a means to identify the parts on his/her tractor when ordering repair parts. The illustrations may or may not represent the actual assemblies; therefore, it is not recommended to use this manual as a guide to assemble or disassemble the tractor. Some hardware and parts are drawn larger in order to more readily identify them.

Each tractor has its own model number. The model number for your tractor can be found on the fender under the seat.

Support / Help

If you require assistance or have questions concerning the application, operation, maintenance or parts for your product:

- Visit our website: www.husqvarna.com
- Call Us Toll Free: 1-800-487-5951

When ordering parts, always give the following information:

- Product - "TRACTOR"
- MODEL NUMBER - "GT48DXLS" (96043023100)"
- Part Number
- Part Description

TABLE OF CONTENTS

SCHEMATIC	3
ELECTRICAL.....	4-5
CHASSIS	6-7
DRIVE.....	8-9
ENGINE.....	10-11
STEERING	12-13
MOWER DECK.....	14-15
MOWER LIFT.....	16
SEAT	17
DECALS.....	18

COMO UTILIZAR ESTE MANUAL

Este manual está diseñado para brindarle al comprador un medio para identificar las piezas del tractor para cuando necesite hacer el pedido de un repuesto. Las ilustraciones pueden o no representar los ensambles reales; por lo tanto, no se recomienda utilizar este manual como una guía para ensamblar o desarmar el tractor. Algunos accesorios y piezas están dibujados en tamaños más grandes para identificarlos con mayor facilidad.

Cada tractor tiene su propio número de modelo. El número de modelo del tractor se encuentra en el guardabarros debajo del asiento.

Soporte / Ayuda

Si necesita asistencia o tiene alguna pregunta acerca de la aplicación, operación, mantenimiento o piezas de su producto:

- Visite nuestro sitio web: www.husqvarna.com
- Llámenos de manera gratuita al: 1-800-487-5951

Cuando haga el pedido de una pieza, siempre brinde la siguiente información:

- Producto: "TRACTOR"
- NÚMERO DE MODELO: "GT48DXLS" (96043023100)"
- Número de pieza
- Descripción de la pieza

ÍNDICE

DIAGRAMA.....	19
DIAGRAMA ELÉCTRICO.....	20-21
CHASIS	22-23
TRANSMISIÓN	24-25
MOTOR.....	26-27
DIRECCIÓN	28-29
PLATAFORMA DE LA CORTADORA DE CÉSPED.....	30-31
ELEVACIÓN DE LA CORTADORA DE CÉSPED.....	32
ASIENTO.....	33
CALCOMANÍAS.....	34

TRACTOR - MODEL NO. GT48DXLS (96043023100), PRODUCT NO. 960 43 02-31 SCHEMATIC

SCH27

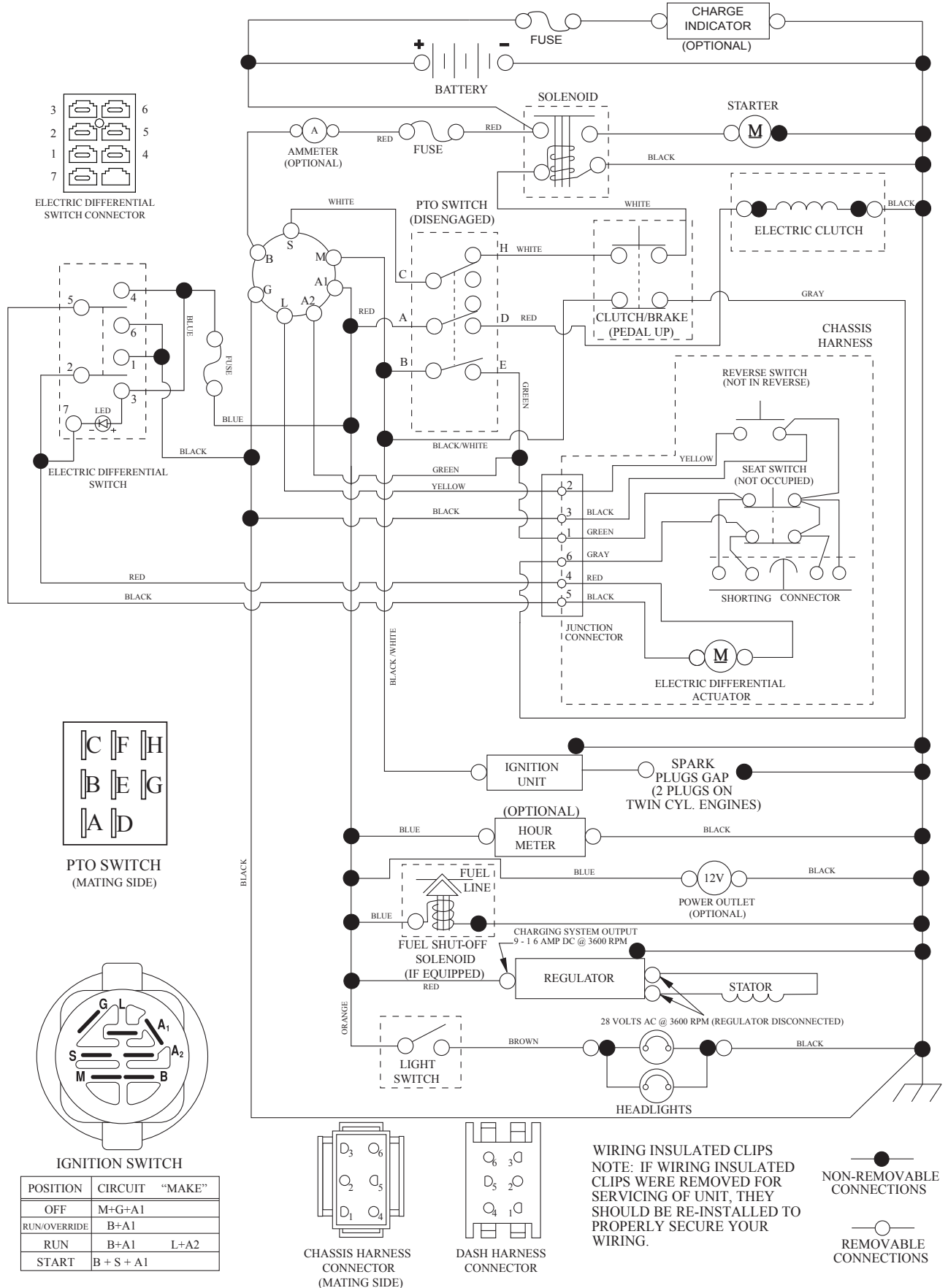

**TRACTOR - MODEL NO. GT48DXLS (96043023100), PRODUCT NO. 960 43 02-31
ELECTRICAL**

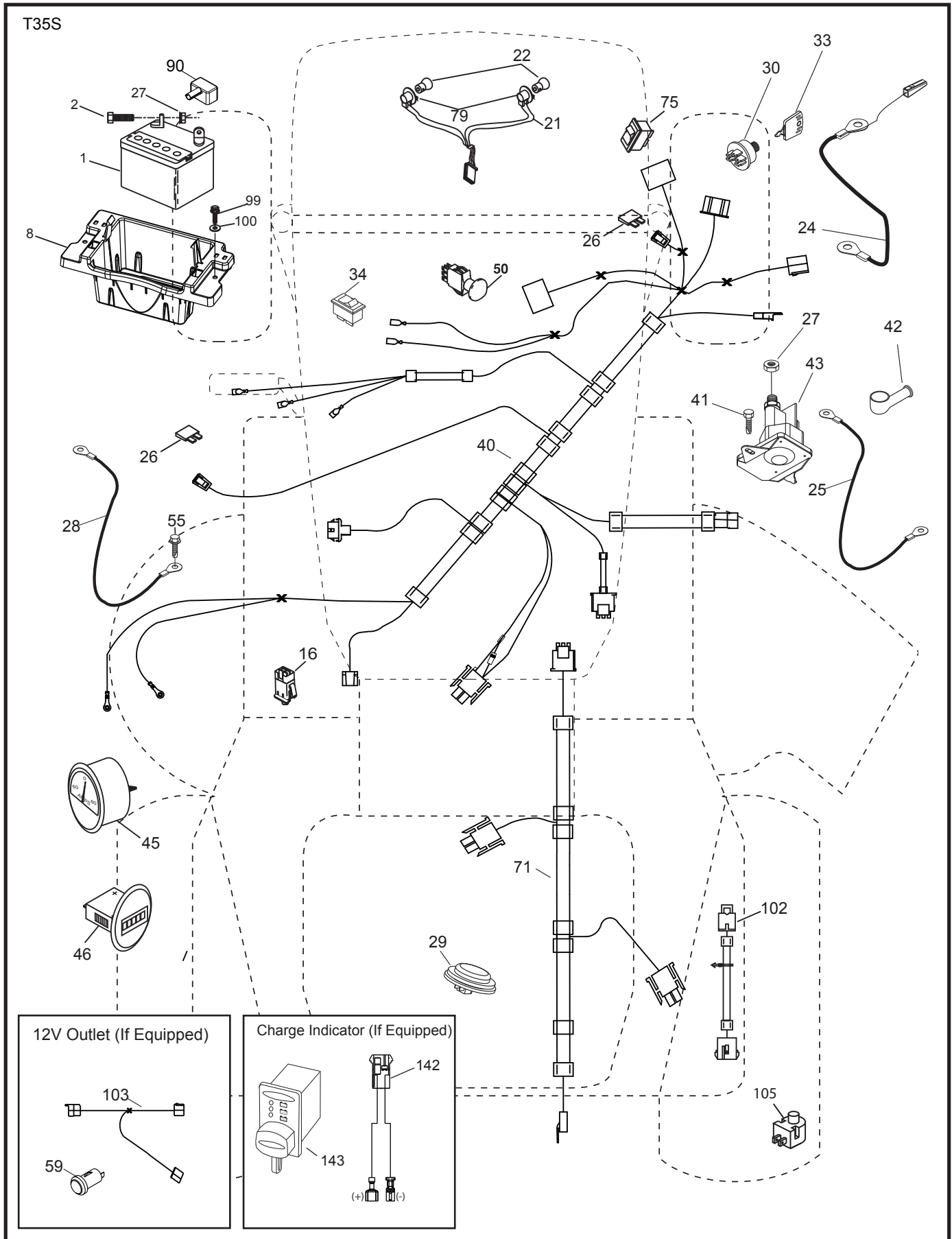

**TRACTOR - MODEL NO. GT48DXLS (96043023100), PRODUCT NO. 960 43 02-31
ELECTRICAL**

KEY NO.	PART NO.	DESCRIPTION
1	532 16 34-65	Battery
2	874 76 04-12	Bolt Hex Hd 1/4-20 unc x 3/4
8	587 20 51-01	Battery Box
16	532 17 61-38	Switch Interlock
21	532 40 02-52	Harness Socket Light
22	532 00 41-52	Bulb, Light #1156
24	585 55 56-01	Cable Battery
25	585 55 55-01	Cable Starter
26	532 17 51-58	Fuse
27	873 51 04-00	Nut Keps Hex 1/4-20 unc
28	532 41 65-88	Cable Ground 21" Blk 6 Ga.
29	532 40 15-45	Switch Seat
30	532 19 33-50	Switch Ign
33	532 41 19-33	Key/Chain
34	532 11 07-12	Switch Light/Reset
40	501 13 36-01	Harness Ign. Dash
41	817 72 04-08	Screw 1/4-20 unc x 1/2
42	532 13 15-63	Cover Terminal Red
43	582 04 28-01	Solenoid
45	587 55 39-03	Ammeter Round
46	587 55 40-03	Gauge Hourmeter
50	582 10 76-01	Switch PTO
55	817 06 05-12	Screw Thdrol 5/16-18 x 3/4
59	532 40 03-03	Outlet 12-Volt
71	580 51 30-01	Harness Ign Chassis
75	580 36 64-01	Switch On/On
79	532 17 52-42	Socket Asm. Bulb Twistlock
90	532 43 53-95	Cover Terminal Battery
99	817 67 04-12	Screw Hexwsh Thdrol 1/4-20 x 3/4
100	819 09 14-16	Washer 9/32 x 7/8 x 16 Ga.
102	532 40 44-54	Harness Pigtail ROS
103	532 42 17-47	Harness Pigtail 12V Outlet
105	532 40 75-68	Switch Reverse
142	583 85 78-01	Harness Charge Port
143	532 44 80-59	Charge Port

NOTE: All component dimensions given in U.S. inches
1 inch = 25.4 mm

**TRACTOR - MODEL NO. GT48DXLS (96043023100), PRODUCT NO. 960 43 02-31
CHASSIS**

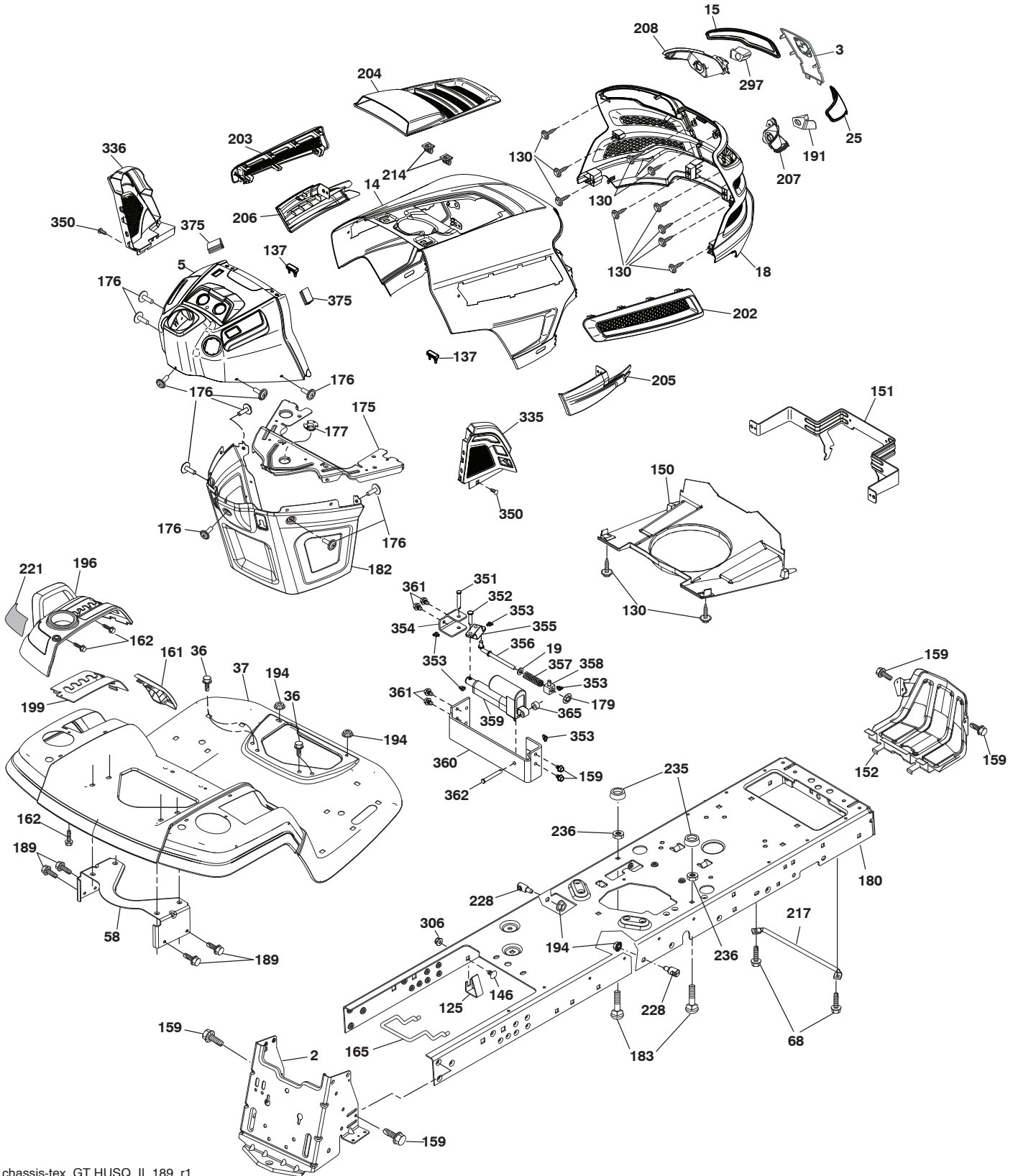

chassis-tex_GT HUSQ_II_189_r1

TRACTOR - MODEL NO. GT48DXLS (96043023100), PRODUCT NO. 960 43 02-31 CHASSIS

KEY NO.	PART NO.	DESCRIPTION
2	580 43 44-01	Drawbar
3	532 44 44-81	Applique Husq.
5	589 71 41-01	Dash
14	532 44 11-77	Hood
15	532 43 97-33	Lens LH
18	532 44 06-53	Grille
19	819 13 13-12	Washer 13/32 x 13/16 x 12 Ga.
25	532 44 33-85	Lens RH
36	817 06 05-12	Screw 5/16-18 x 3/4
37	532 44 12-08	Fender
58	532 19 43-14	Bracket Fender
68	817 49 05-08	Screw 5/16-18 x 1/2
125	581 68 48-01	Clip Fuel Line
130	532 41 63-58	Screw #10 x 0.750 BOS Thread
137	532 40 75-90	Bumper Dash
146	581 85 79-01	Bolt
150	532 43 97-74	Duct Heat Hood
151	532 43 66-70	Bracket Pivot Hood
152	532 43 98-70	Shield Browning
159	817 00 06-12	Screw 3/8-16 x 3/4
161	532 43 99-29	Console Fuel Window
162	532 14 24-32	Screw Hex Wsh Hi-Lo 1/4 x 1/2
165	532 19 43-30	Bracket Support Tank
175	532 19 63-04	Crossmember
176	532 40 07-76	Screw 10-24 x 5/8 Wshd Qdrx
177	532 19 52-28	Bushing Steering
179	532 16 89-37	Nut Push
180	532 44 55-59	Chassis
182	532 40 68-59	Dash Lower
183	874 52 05-20	Bolt 5/16-18 x 1-1/4
189	817 00 05-12	Screw 5/16-18 x 3/4
191	532 43 74-55	Insert Reflect. RH
194	873 90 05-00	Nut Lock Hex Flange 5/16-18
196	532 43 96-74	Console Asm. Deck Lift
199	532 19 82-59	Plate Deck Lift
202	532 43 97-28	Vent Side Hood RH
203	532 43 97-27	Vent Side Hood LH

KEY NO.	PART NO.	DESCRIPTION
204	532 43 57-14	Vent Asm Hood Top
205	532 43 97-30	Trim Hood Side RH
206	532 43 97-29	Trim Hood Side LH
207	532 43 97-34	Bezel RH
208	532 43 97-35	Bezel LH
214	532 19 91-45	Clip Retainer
217	532 40 91-67	Rod Pivot
221	532 19 89-09	Reflector LH
228	532 19 51-61	Stud Fastener
235	532 40 61-29	Spacer Fender
236	873 93 05-00	Nut Center Lock 5/16-18 unc
297	532 43 74-56	Insert Reflect. LH
306	873 90 06-00	Nut Lock
335	532 44 82-04	Cover RH Lower
336	532 44 53-09	Cover LH Lower
350	532 44 51-43	Clip X-mas Tree
351	532 42 17-34	Pin Clevis .375 x 2.125
352	532 44 86-34	Clevis .375 x 2.125
353	532 17 80-62	Clip Retainer .0375
354	532 44 86-19	Support Bellcrank
355	532 44 86-36	Bellcrank Pivot Lock Diff
356	532 44 86-93	Link Lock Diff
357	532 44 86-84	Spring Compression
358	580 36 66-01	Swivel Guide
359	584 39 34-01	Actuator Electric
360	532 44 86-18	Bracket Actuator
361	817 49 06-10	Screw Hxwsh Thdr 3/8-16 x 5/8
362	532 44 86-33	Clevis .375 x 2.42
365	532 44 73-68	Nylon Spacer .375 x .4375L
375	586 90 82-01	Dash Clip-On Bumper
--	532 43 18-82	Kit Guard Brush

NOTE: All component dimensions given in U.S. inches
1 inch = 25.4 mm

TRACTOR - MODEL NO. GT48DXLS (96043023100), PRODUCT NO. 960 43 02-31
DRIVE

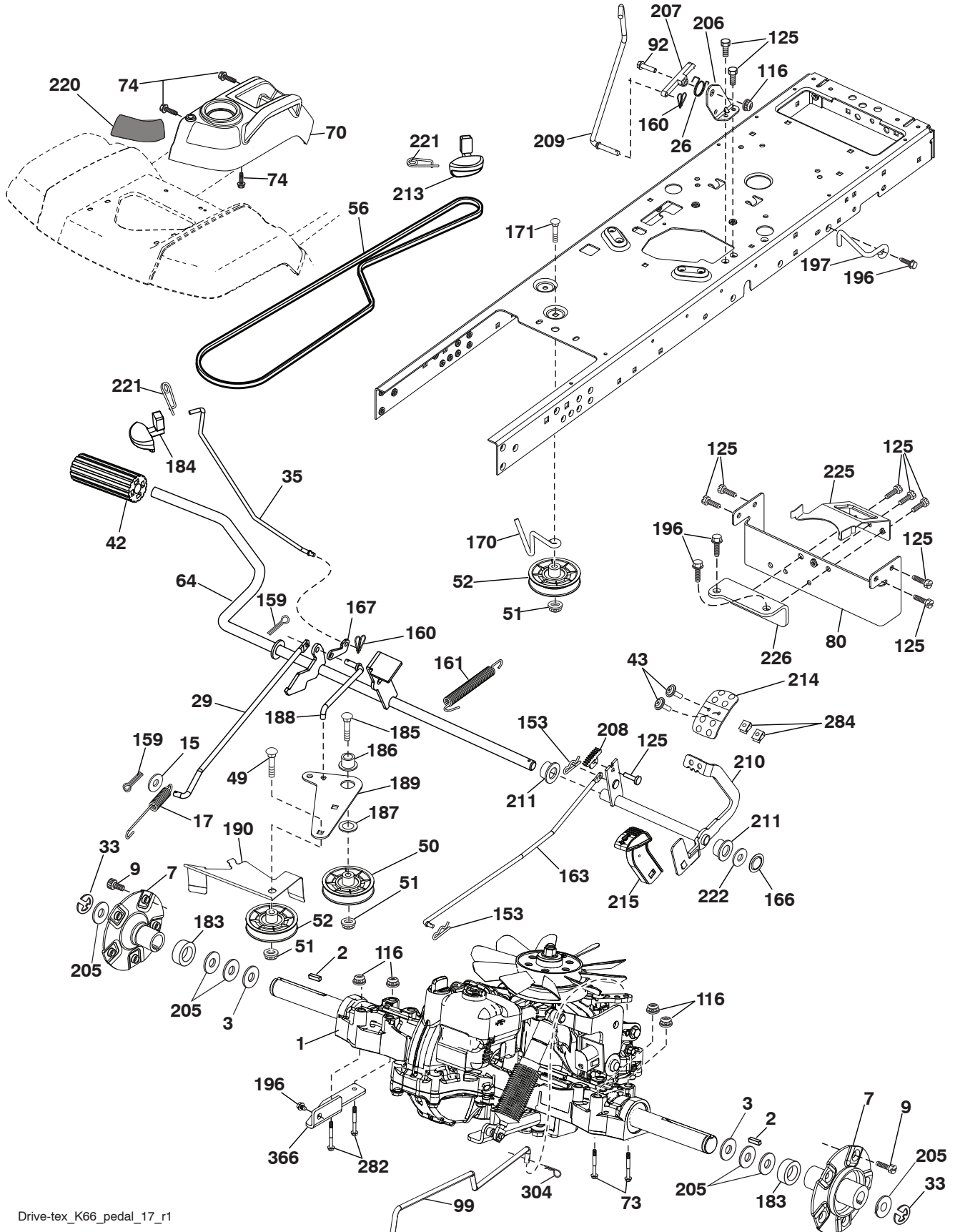

Drive-tex_K66_pedal_17_r1

TRACTOR - MODEL NO. GT48DXLS (96043023100), PRODUCT NO. 960 43 02-31 DRIVE

KEY NO.	PART NO.	DESCRIPTION	KEY NO.	PART NO.	DESCRIPTION
1	---	Transaxle, Tufftorq K66ELD (580402201) (Order parts from transaxle manufacturer.)	167	532 40 52-57	Latch Brake Parking
2	539 91 27-57	Key .25 x 1.25	170	532 19 43-22	Keeper V-Idler Centerspan
3	532 00 75-63	Washer Thrust Axle Hardened	171	872 11 06-16	Keeper V-Idler Centerspan
7	586 93 54-02	Hub Asm. Wheel	183	501 05 15-01	Spacer Axle
9	532 14 00-80	Bolt Hub Wheel	184	587 65 37-01	Handle Parking Brake
15	819 13 13-16	Washer 13/32 x 13/16 x 16 Ga.	185	872 11 06-22	Bolt Rdhd 3/8-16 unc x 2-3/4 G5
17	532 40 10-72	Spring, Brake	186	532 19 43-21	Spacer Retainer
26	532 19 96-79	Spring Return Cruise	187	819 13 32-10	Washer
29	532 40 72-45	Rod, Brake	188	582 21 70-01	Link Clutch Ground Drive Long
33	812 00 00-53	Ring E	189	532 19 43-17	Bellcrank Ground Drive
35	583 86 45-01	Rod, Brake, Park	190	532 19 43-18	Keeper Bellcrank Ground Drive
42	532 12 48-72	Cover, Foot Pedal	196	817 00 06-16	Screw 3/8-16 x 1
43	874 18 04-12	Screw Mach. CR. 1/4-20 x 3/4	197	585 65 86-01	Bracket Clutch Anti-Rotation
49	872 11 06-14	Bolt	205	532 12 38-00	Washer 1-1/32 x 1-5/8 x 16 Ga.
50	532 19 43-27	Pulley Idler Flat	206	532 44 85-96	Bracket Mount Latch Cruise
51	873 90 06-00	Lock Nut 3/8-16	207	587 03 14-01	Latch Control Cruise
52	532 19 43-26	Idler V-Groove	208	532 19 78-69	Gear Sector Control Cruise
56	532 12 59-07	V-Belt, Drive	209	532 19 95-92	Rod Control Cruise
64	532 19 78-65	Shaft Asm. Pedal Brake Control	210	532 19 78-60	Rocker Asm. Pedal Control
70	532 43 96-61	Console Asm	211	532 12 01-83	Bearing Nylon
73	874 49 05-44	Bolt Hex Flghd 5/16-18 Gr. 5	213	532 40 31-19	Knob Control Cruise
74	532 14 24-32	Screw 1/4 x 1/2	214	532 41 68-63	Pedal Forward
80	583 97 07-01	Strap Torque	215	586 60 65-02	Pedal Reverse
92	874 76 05-20	Bolt 5/16-18 x 1/2	220	532 19 89-08	Reflector RH
99	582 40 47-01	Spring Bypass	221	532 40 31-87	Retainer Spring Clip Handle
116	873 90 05-00	Nut Lock Hex Flange 5/16-18	222	879 21 20-10	Washer 21/32 x 1-1/4 x 10 Ga.
125	817 00 05-12	Screw 5/16-18 x 3/4	225	532 40 73-11	Keeper Belt
153	532 12 47-88	Retainer Spring	226	532 40 71-09	Bracket Mount Torque
159	876 02 04-12	Pin Cotter 1/8 x 3/4	282	874 49 05-48	Bolt 5/16-18 x 3.0 G5
160	532 16 94-84	Retainer Clip	284	532 41 76-93	Nut U-Chnl. 1/4-20
161	532 10 57-09	Spring, Return, Clutch	304	532 42 33-03	Pin
163	532 40 72-46	Rod Pedal Control	366	580 62 62-01	Bracket Reinforcement
166	532 42 91-64	Nut Push .625			

NOTE: All component dimensions given in U.S. inches
1 inch = 25.4 mm

**TRACTOR - MODEL NO. GT48DXLS (96043023100), PRODUCT NO. 960 43 02-31
ENGINE**

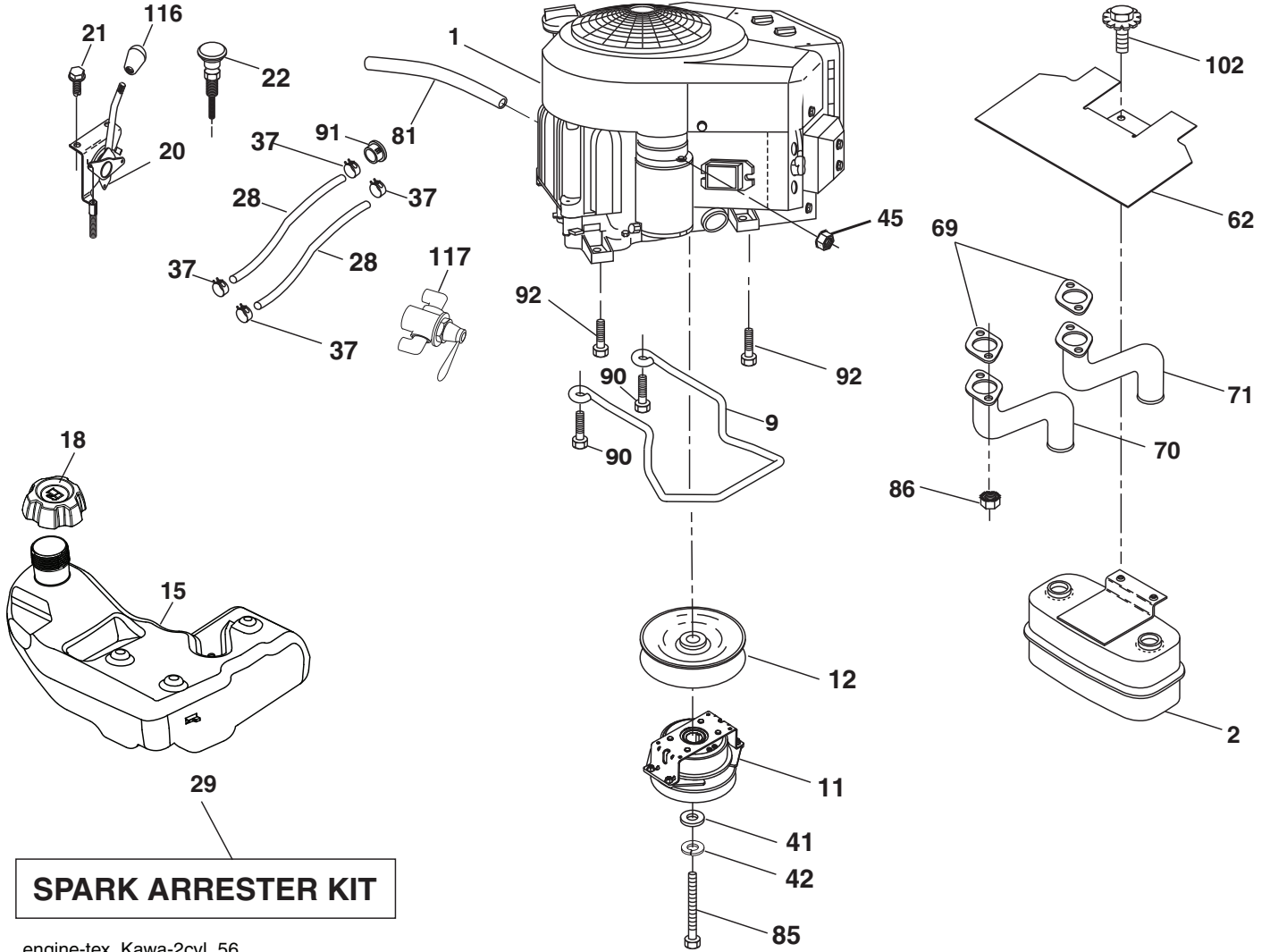

engine-tex_Kawa-2cyl_56

TRACTOR - MODEL NO. GT48DXLS (96043023100), PRODUCT NO. 960 43 02-31
STEERING ASSEMBLY

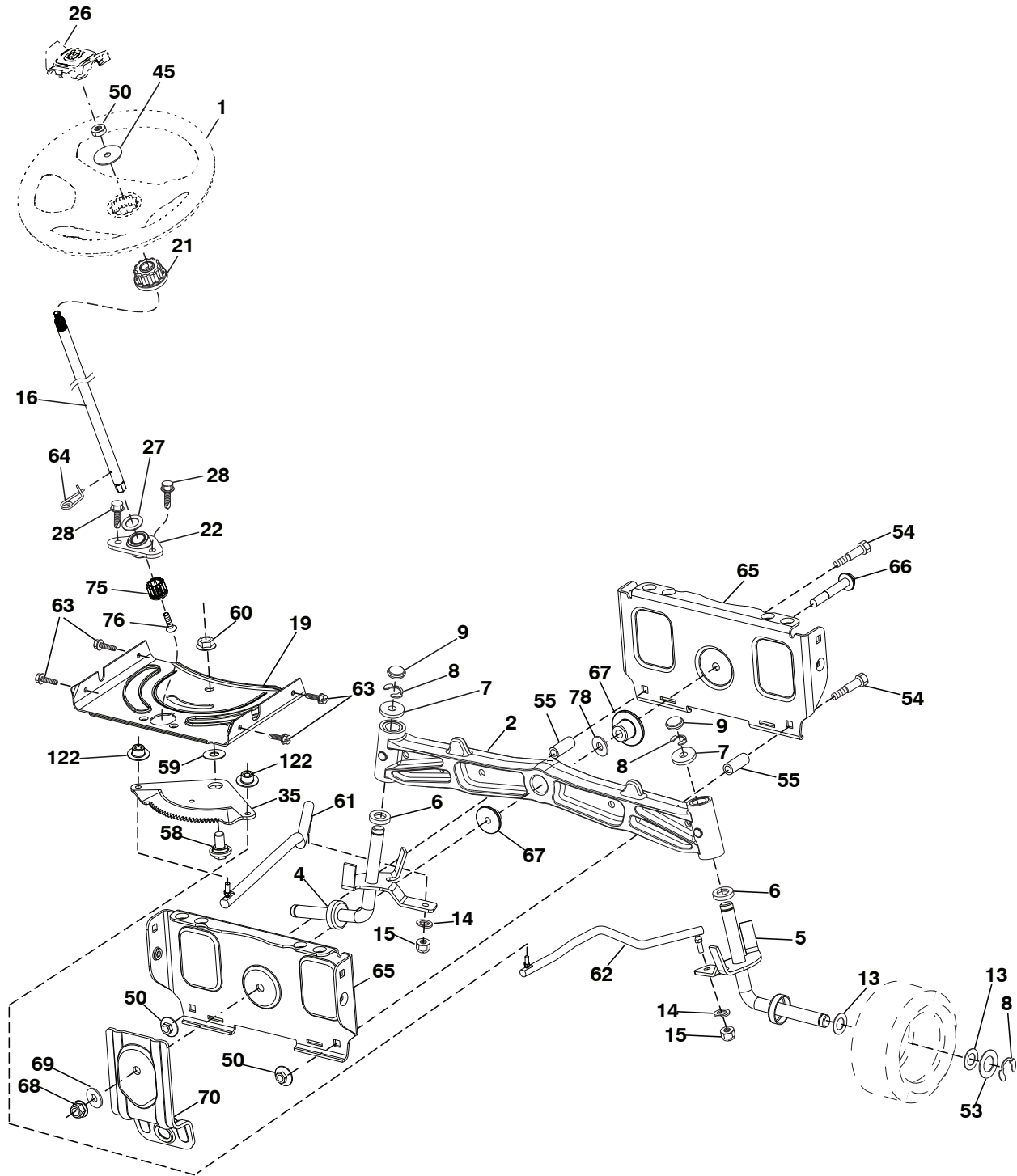

steering-tex_HUSQSR_63

**TRACTOR - MODEL NO. GT48DXLS (96043023100), PRODUCT NO. 960 43 02-31
STEERING ASSEMBLY**

KEY NO.	PART NO.	DESCRIPTION
1	532 43 97-40	Wheel, Steering
2	532 19 59-68	Axle Asm., Front
4	532 40 30-89	Spindle Asm. LH
5	532 40 30-90	Spindle Asm. RH
6	532 12 49-31	Bearing, Race Thrust Harden
7	532 12 17-48	Washer 25/32 x 1-5/8 x 16 Ga.
8	812 00 00-29	Ring, Clip #T5304-75
9	532 12 12-32	Cap, Spindle
13	532 12 17-49	Washer 25/32 x 1-1/4 x 16 Ga.
14	810 04 06-00	Washer, Lock Hvy Hlcl Spr 3/8
15	873 54 06-00	Nut, Crown Lock 3/8-24 unf
16	587 01 60-02	Steering Shaft
19	532 19 47-29	Plate Steering
21	586 84 02-01	Adapter Wheel Steering
22	585 02 98-02	Bearing
26	532 43 97-43	Insert, Wheel Steering
27	819 21 16-16	Washer
28	817 00 06-12	Screw 3/8-16 x 3/4
35	532 19 47-32	Gear, Sector Plate
45	587 01 64-01	Washer 3/8 ID 2-3/8 OD 12 Ga. PLTD
50	873 90 06-00	Nut Lock Flg 3/8-16 unc
53	532 18 89-67	Washer Hardened .793 x 1.637 x .060
54	874 76 06-36	Bolt Hex 3/8-16 unc x 2-1/4
55	532 41 47-36	Bolt Hex 3/8-16 unc x 2-1/4
58	532 19 47-47	Bolt Shoulder Sector Pivot CFM
59	532 19 47-48	Washer Thrust Sector Steering
60	873 97 10-00	Nut Flange Lock 5/8-11
61	532 19 47-40	Draglink, LH
62	532 19 47-41	Draglink, RH
63	817 00 05-12	Screw 5/16-18 x 3/4
64	532 19 98-49	Retainer Clip Spring Steering
65	532 19 47-34	Brace Axle Front
66	871 02 07-48	Bolt Hex Fghd 7/16-14 x 3 Serr
67	532 19 47-37	Bushing PM Front Axle
68	873 90 07-00	Nut Lock Flange 7/16-14 Gr. 5
69	532 19 91-62	Washer 1.5 x .505 x .118
70	585 33 88-01	Bracket Deck Susp. Front
75	580 68 37-01	Pinion
76	580 68 36-01	Screw Head Sock
78	532 05 70-79	Washer Thrust
122	532 44 49-62	Cap Gear Sector

NOTE: All component dimensions given in U.S. inches
1 inch = 25.4 mm

TRACTOR - MODEL NO. GT48DXLS (96043023100), PRODUCT NO. 960 43 02-31
MOWER DECK

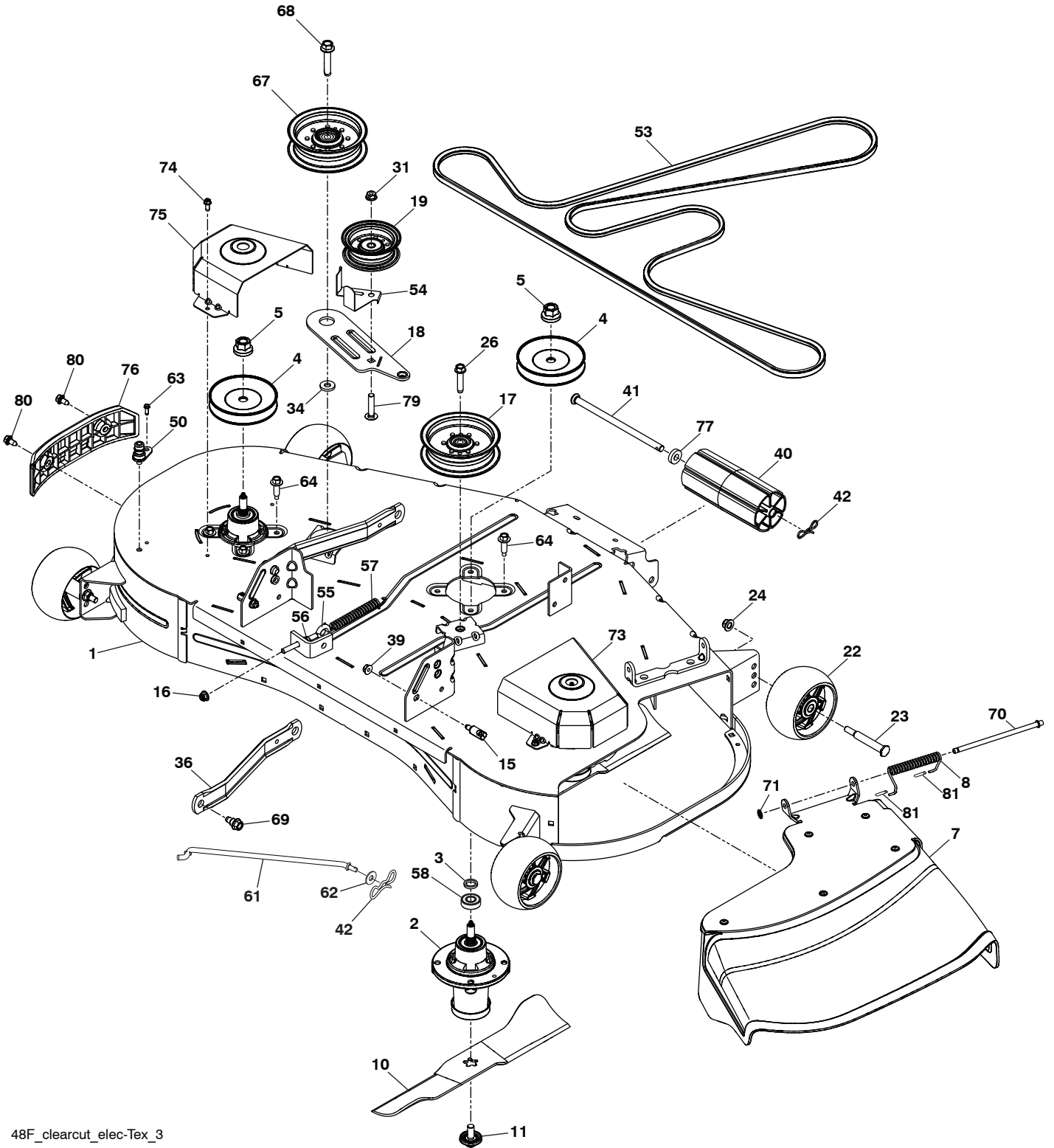

48F_clearcut_elec-Tex_3

**TRACTOR - MODEL NO. GT48DXLS (96043023100), PRODUCT NO. 960 43 02-31
MOWER DECK**

KEY NO.	PART NO.	DESCRIPTION	KEY NO.	PART NO.	DESCRIPTION
1	588 78 80-02	Deck	55	539 11 55-74	Eyebolt 5/16 x 3-1/2
2	539 13 18-98	Housing Assembly	56	539 99 05-85	Nut 5/16-18 Hx
3	532 18 76-90	Washer-Spacer	57	587 35 84-01	Spring Extn.
4	532 17 34-34	Pulley, Mandrel	58	532 11 04-85	Ball Bearing
5	532 40 02-34	Nut Flange Lock Top	61	532 40 03-37	Rod Anti-Sway
7	588 98 07-01	Deflector Asm. 48"	62	819 13 13-12	Washer 13/32 x 13/16 x 12 Ga.
8	587 35 47-01	Spring - Torsion	63	817 49 04-10	Screw 1/4-20 x 5/8 Hx Self Tap ZD
10	588 81 10-02	Blade	64	584 95 39-01	Bolt Hex Washer Head .313-18 x 1.19
11	532 19 30-03	Bolt Washer Assy 7/16-20	67	532 19 61-06	Pulley Idler
15	532 19 51-61	Stud, Fasten w/ Anti- Rotate	68	817 49 06-28	Screw Thdrl 3/8-16 x 1-3/4 TT
16	539 11 28-99	Nut 5/16-18 Hx Flng NYLOC	69	532 19 65-39	Bolt Shoulder
17	532 19 61-04	Pulley, Idler Spec. Hub	70	532 13 14-91	Rod Hinge
18	588 81 23-02	Arm Idler	71	532 11 04-52	Nut Push
19	532 19 31-97	Pulley, Idler	73	588 81 24-02	Cover Mandrel RH
22	532 17 48-73	Wheel, Gauge	74	532 13 77-29	Screw Thdrl 1/4-20 x 5/8
23	532 19 34-06	Bolt Shoulder 3/8-16 x 3-5/8	75	588 81 31-02	Cover Mandrel LH
24	521 99 65-01	Nut 3/8-16 Hex Flg Nyloc	76	582 54 11-01	Bumper Side Trim
26	588 43 83-01	Screw 7/16-14 x 2.125 Wsh	77	582 36 05-01	Bushing Nose Roller
31	873 90 06-00	Nut Lock Flng 3/8-16 unc	79	872 11 06-14	Bolt RdHd 3/8-16 unc x 1-3/4 Gr. 5
34	532 17 85-15	Washer, Flat Hardened	80	532 17 01-65	Bolt 5/16
36	532 19 51-85	Arm, Susp., Rear	81	532 10 53-04	Cap Sleeve
39	873 90 05-00	Nut Lock Hx Flng 5/16-18	--	532 41 64-05	Connect Quick Coupling
40	532 17 60-66	Roller, Nose, 48"	--	589 42 88-01	Service Deck
41	532 17 91-27	Rod, Roller, Nose, Narrow			
42	532 19 42-08	Pin Cotter			
50	532 41 55-98	Washout Port			
53	588 81 43-01	Belt, Deck			
54	532 14 10-43	Guard, Belt			

NOTE: All component dimensions given in U.S. inches
1 inch = 25.4 mm

**TRACTOR - MODEL NO. GT48DXLS (96043023100), PRODUCT NO. 960 43 02-31
MOWER LIFT**

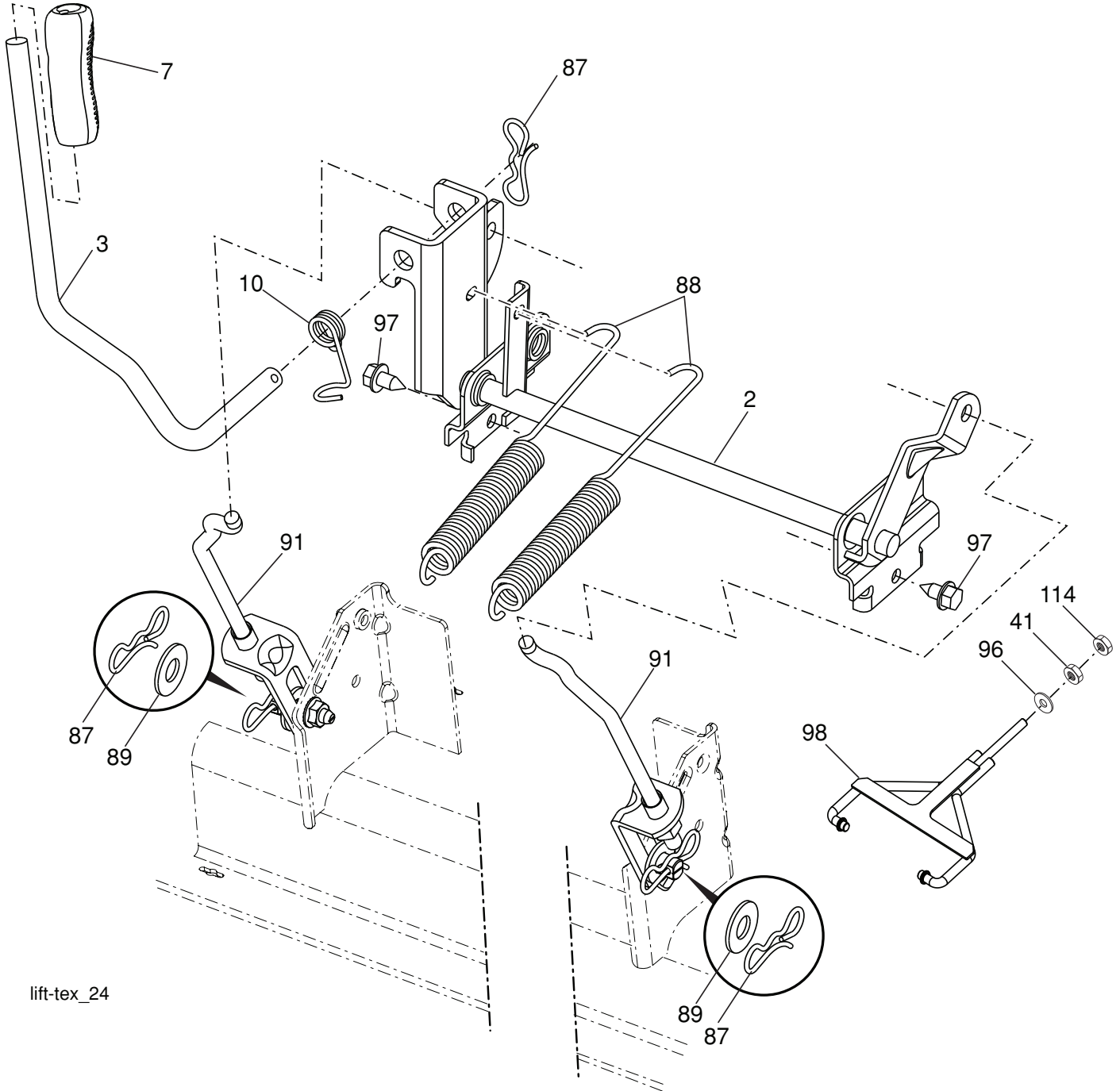

lift-tex_24

KEY NO.	PART NO.	DESCRIPTION
2	532 42 20-27	Shaft Asm., Lift
3	532 19 52-30	Lever Asm., Lift RH
7	580 96 23-01	Grip, Lever
10	532 19 63-14	Spring Torsion
41	532 17 59-94	Nut Lift Link
87	532 19 42-09	Pin Cotter 7/16 Bow Tie Lock
88	532 19 53-04	Spring Lift Assist
89	819 19 19-12	Washer Clear Zinc

KEY NO.	PART NO.	DESCRIPTION
91	532 40 34-07	Link Lift Susp Mower Rear
96	532 19 52-63	Bushing Spherical
97	817 00 06-12	Screw 3/8-16 x .75
98	574 82 25-01	Link Lift Susp. Front Mower
114	873 36 07-00	Nut Jam 7/16-20

NOTE: All component dimensions given in U.S. inches
1 inch = 25.4 mm

**TRACTOR - MODEL NO. GT48DXLS (96043023100), PRODUCT NO. 960 43 02-31
SEAT ASSEMBLY**

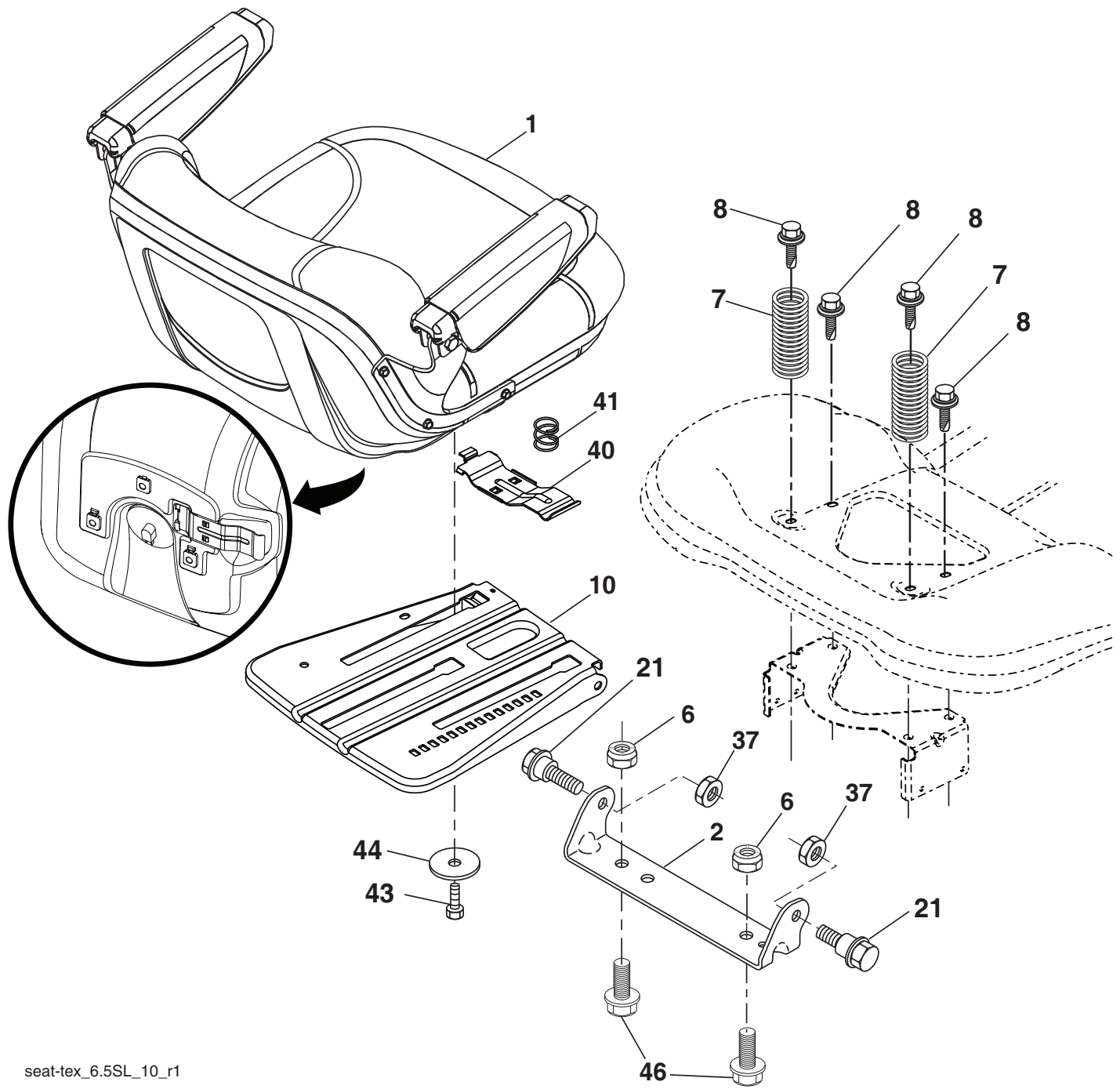

seat-tex_6.5SL_10_r1

KEY NO.	PART NO.	DESCRIPTION
1	532 44 32-63	Seat
2	532 18 01-66	Bracket Pivot Fender
6	873 80 06-00	Nut, Lock w/Ins. 3/8-16 unc
7	587 61 33-01	Spring, Seat Cprsn
8	532 17 18-77	Bolt 5/16-18 unc x 3/4 w/Sems
10	532 19 69-77	Pan, Seat
21	587 90 78-01	Bolt, Shoulder 5/16-18 x 5/8
37	873 80 05-00	Nut, Lock 5/16-18 unc

KEY NO.	PART NO.	DESCRIPTION
40	532 19 76-61	Handle Slide Seat
41	532 19 82-00	Spring Latch Seat
43	874 76 06-12	Bolt Fin Hex 3/8-16 unc x 3/4
44	819 13 38-12	Washer 13/32 x 2-3/8 x 12 Ga.
46	588 09 04-01	Bolt 3/8-16 x 1, 1.25 OD

NOTE: All component dimensions given in U.S. inches
1 inch = 25.4 mm

**TRACTOR - MODEL NO. GT48DXLS (96043023100), PRODUCT NO. 960 43 02-31
DECALS**

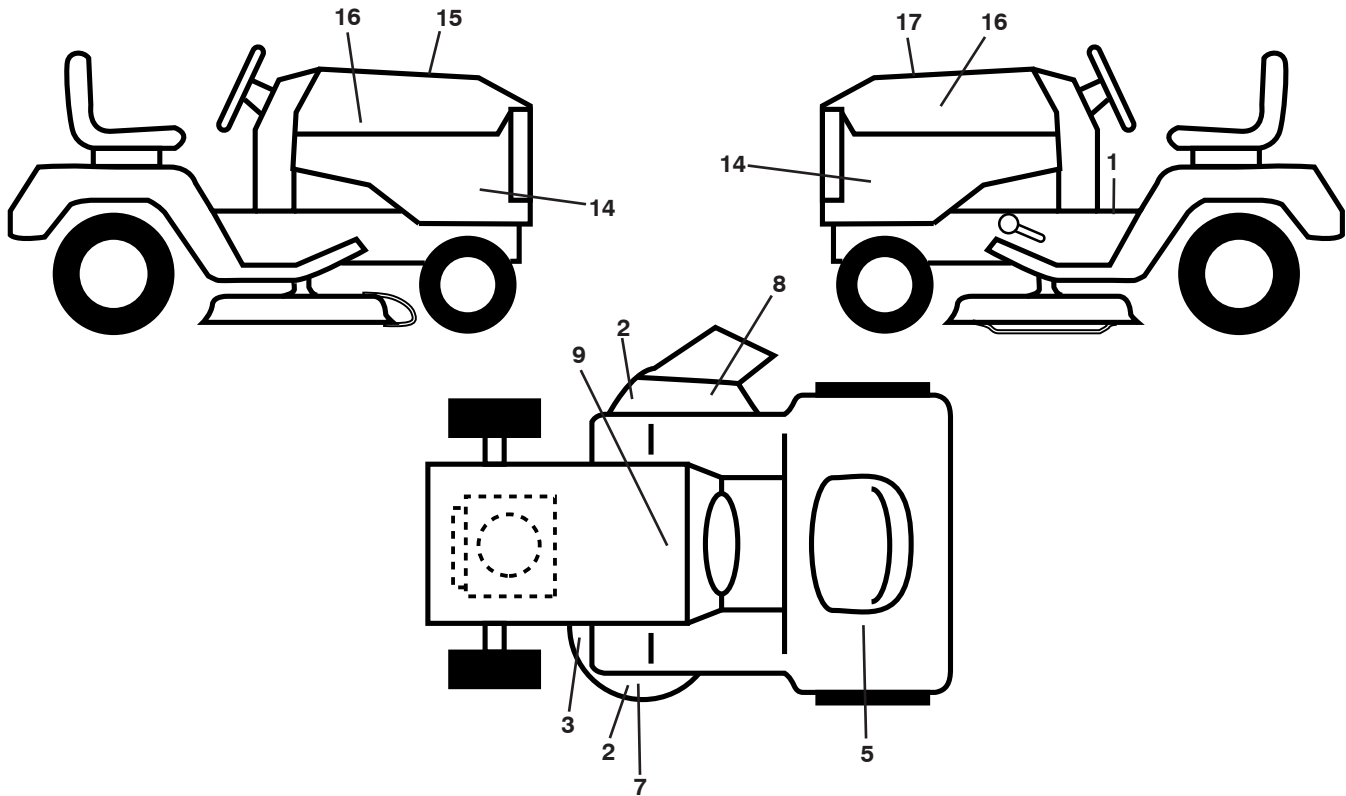

KEY NO.	PART NO.	DESCRIPTION
1	581 57 89-01	Decal, Warning
2	589 35 79-01	Decal, No Step
3	539 11 26-20	Decal, Belt Routing
5	587 01 51-01	Decal, Warning Reserve
7	532 44 81-21	Decal, Deck HV Reinforced
8	586 97 88-01	Decal, Deflect. Warning
9	532 14 50-05	Decal, Battery Dnqe/Poi
14	589 65 54-01	Decal, Panel Side
15	532 42 38-29	Decal, Cust. Resp.
16	581 62 73-01	Decal, Hood Logo

KEY NO.	PART NO.	DESCRIPTION
17	589 62 66-01	Decal, Replacement
--	581 72 48-01	Decal, Bypass
--	532 43 98-82	Pad, Footrest, LH
--	532 43 98-81	Pad, Footrest, RH
--	115 86 32-26	Manual, Operator's (English/Spanish)
--	115 86 33-26	Manual, Part's (English/Spanish)
--	587 71 00-26	Manual, QSG Husq (English/Spanish)

WHEELS AND TIRES

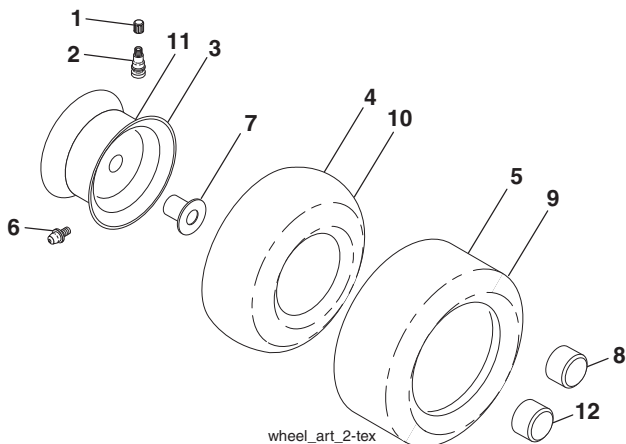

KEY NO.	PART NO.	DESCRIPTION
1	532 05 91-92	Cap, Valve, Tire
2	532 06 51-39	Stem, Valve
3	532 18 18-39	Rim Assembly, Front
4	532 00 81-34	Tube, Front (Service Item Only)
5	532 16 10-24	Tire, Front 16 x 6.5-8
6	532 12 49-57	Fitting, Grease (Front Wheel Only)
7	532 12 49-59	Bearing, Flange (Front Wheel Only)
8	532 17 50-39	Cap, Axle, Front
9	532 17 04-53	Tire, Rear 23 x 10.5-12
10	532 00 71-54	Tube, Rear (Service Item Only)
11	532 14 45-10	Rim Assembly, Rear
12	501 50 31-01	Cap, Hub, GT, PM, Black, Rear
--	532 14 43-34	Sealant, Tire (10 oz. Tube)

NOTE: All component dimensions given in U.S. inches
1 inch = 25.4 mm

TRACTOR MODELO NO. GT48DXLS (96043023100), PRODUCTO NO. 960 43 02-31

DIAGRAMA

SCH27-s

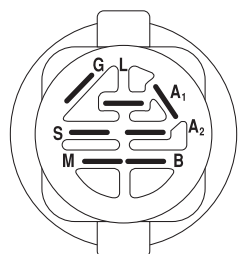
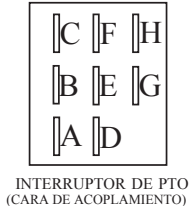
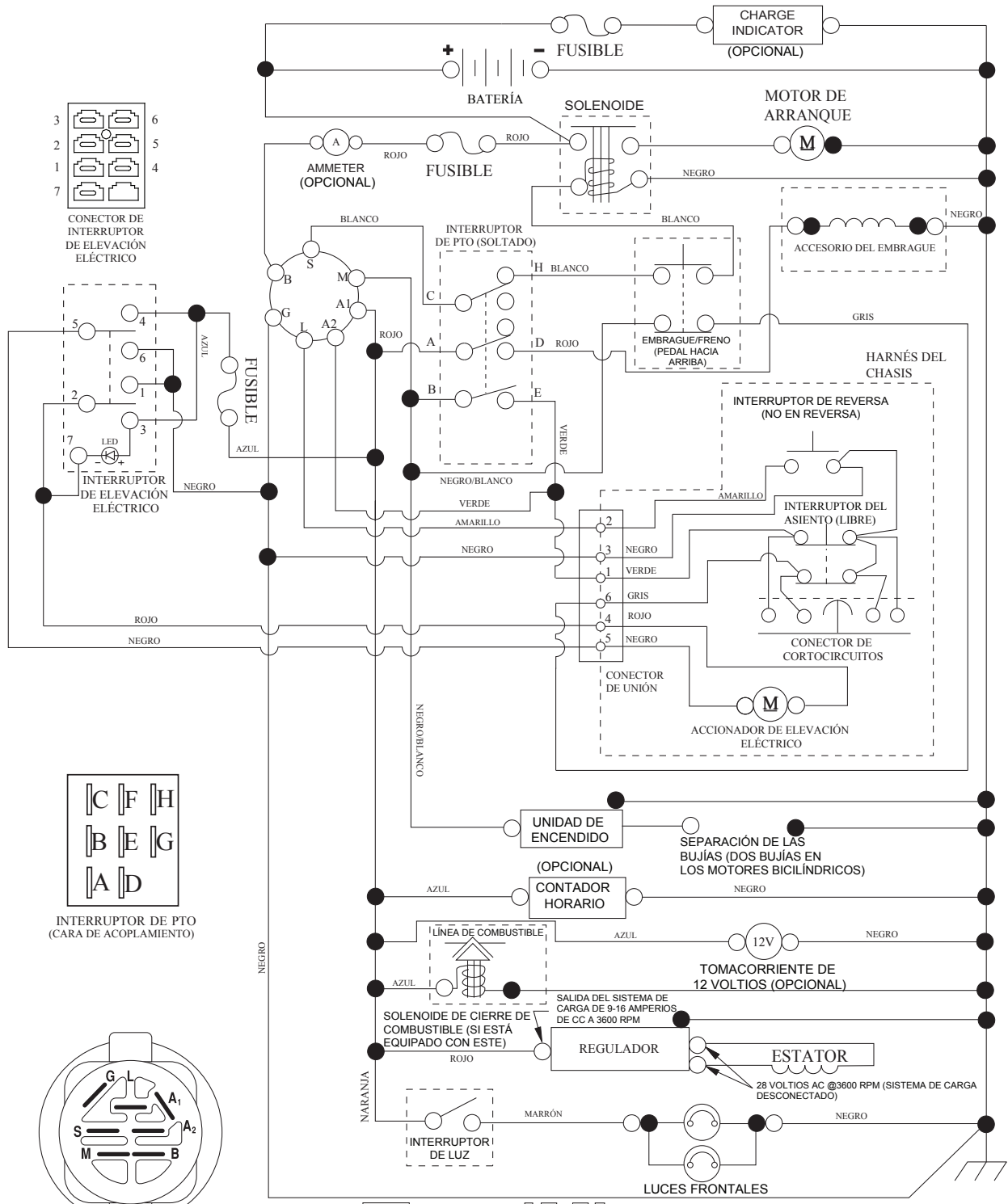

POSICIÓN	CIRCUITO «MARCA»
APAGADO	M+G+A1
PONER EN FUNCIONAMIENTO ANULAR	B+A1
PONER EN FUNCIONAMIENTO	B+A1 L+A2
ARRANCAR	B + S + A1

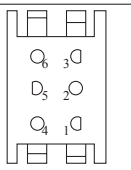
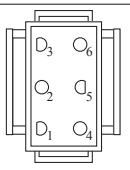

NOTA SOBRE LAS ABRAZADERAS DE AISLAMIENTO DEL CABLEADO: SI SE QUITAN LAS ABRAZADERAS DE AISLAMIENTO DEL CABLEADO PARA HACER EL MANTENIMIENTO DE LA UNIDAD, SE LAS DEBERÁ INSTALAR NUEVAMENTE PARA PROTEGER EL CABLEADO ADECUADAMENTE.



TRACTOR MODELO NO. GT48DXLS (96043023100), PRODUCTO NO. 960 43 02-31

DIAGRAMA ELÉCTRICO

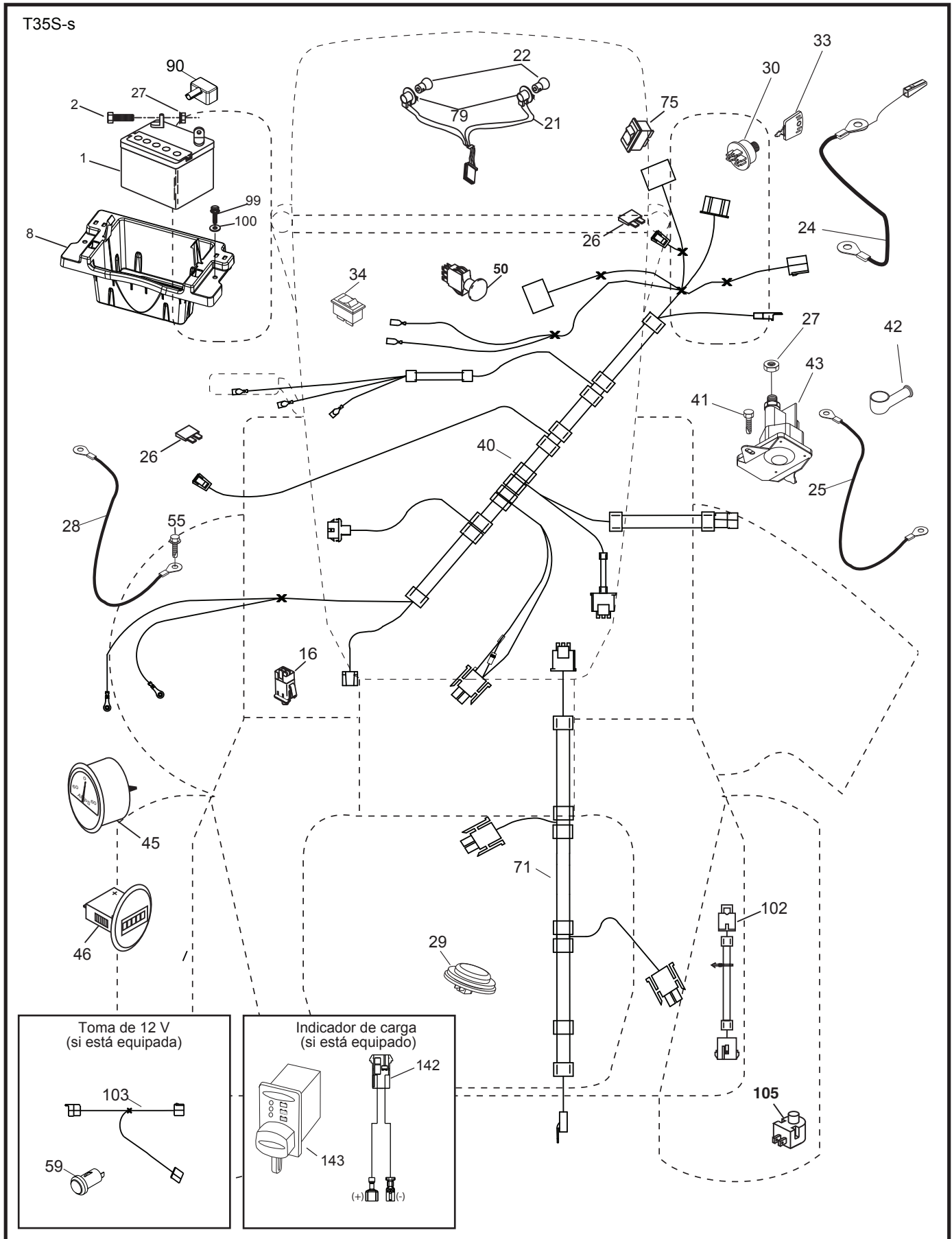

**TRACTOR MODELO NO. GT48DXLS (96043023100), PRODUCTO NO. 960 43 02-31
DIAGRAMA ELÉCTRICO**

CÓDIGO No.	PIEZA No.	DESCRIPCIÓN
1	532 16 34-65	Batería
2	874 76 04-12	Perno de cabeza hexagonal de 1/4-20 x 3/4
8	587 20 51-01	Caja de la batería
16	532 17 61-38	Interruptor corta corriente a presión
21	532 40 02-52	Cableado del enchufe para la luz
22	532 00 41-52	Bombilla de luz
24	585 55 56-01	Cable
25	585 55 55-01	Cable
26	532 17 51-58	Fusible
27	873 51 04-00	Tuerca hexagonal Keps de 1/4-20 unc
28	532 41 65-88	Cable a tierra
29	532 40 15-45	Interruptor del asiento
30	532 19 33-50	Interruptor de encendido
33	532 41 19-33	Llave/cadena
34	532 11 07-12	Interruptor de luz/de restauración
40	501 13 36-01	Cableado de encendido
41	817 72 04-08	Tornillo
42	532 13 15-63	Cubierta de la terminal
43	582 04 28-01	Solenoides
45	587 55 39-03	Indicador SRVCMNDR
46	587 55 40-03	Indicador HRMTR
50	582 10 76-01	Interruptor
55	817 06 05-12	Tornillo de 5/16-18 x 3/4
59	532 40 03-03	Enchufe, 12V
71	580 51 30-01	Cableado de encendido, chasis
75	580 36 64-01	Interruptor
79	532 17 52-42	Enchufe de cierre por torsión del ensamble de la bombilla
90	532 43 53-95	Tapa de los bornes de la batería
99	817 67 04-12	Tornillo 1/4-20 x 3/4
100	819 09 14-16	Arandela
102	532 40 44-54	Cableado
103	532 42 17-47	Cable 12V
105	532 40 75-68	Interruptor
142	583 85 78-01	Cableado de conector de carga
143	532 44 80-59	Conector de carga

NOTA: Las dimensiones de todos los componentes están expresadas en pulgadas americanas. 1 pulgada = 25,4 mm

**TRACTOR MODELO NO. GT48DXLS (96043023100), PRODUCTO NO. 960 43 02-31
CHASIS**

CÓDIGO PIEZA			CÓDIGO PIEZA		
No.	No.	DESCRIPCIÓN	No.	No.	DESCRIPCIÓN
2	580 43 44-01	Barra de tracción	203	532 43 97-27	Salida de Ventilación (LI)
3	532 44 44-81	Aplica	204	532 43 57-14	Salida de Ventilación superior
5	589 71 41-01	Tablero	205	532 43 97-30	Camisa de Capota (LD)
14	532 44 11-77	Capota	206	532 43 97-29	Camisa de Capota (LI)
15	532 43 97-33	Lente izquierdo de la parrilla	207	532 43 97-34	Bisel derecho
18	532 44 06-53	Parrilla	208	532 43 97-35	Bisel izquierdo
19	819 13 13-12	Arandela de 13/32 x 13/16 x 12 calibre 16	214	532 19 91-45	Cierre
25	532 44 33-85	Lente derecho de la parrilla	217	532 40 91-67	Varilla giratoria
36	817 06 05-12	Tornillo 5/16-18 x 3/4	221	532 19 89-09	Reflector (LI)
37	532 44 12-08	Guardabarros	228	532 19 51-61	Sujetador del travesaño
58	532 19 43-14	Soporte	235	532 40 61-29	Separador del guardabarros
68	817 49 05-08	Tornillo 5/16-18 x 1/2	236	873 93 05-00	Tuerca 5/16-18 unc
125	581 68 48-01	Cierre	297	532 43 74-56	Parrilla reflector (LI)
130	532 41 63-58	Tornillo #10 x 0.750	306	873 90 06-00	Tuerca
137	532 40 75-90	Cubierta Tablero	335	532 44 82-04	Cubierta (LD)
146	581 85 79-01	Perno	336	532 44 53-09	Cubierta (LI)
150	532 43 97-74	Cubierta térmica del conducto	350	532 44 51-43	Clip del árbol de navidad
151	532 43 66-70	Soporte	351	532 42 17-34	Clavija de horquilla .375 x 2.125
152	532 43 98-70	Protector contra oscurecimiento	352	532 44 86-34	Clavija .375 x 2.125
159	817 00 06-12	Tornillo 3/8-16 x 3/4	353	532 17 80-62	Pinzas de retención .0375
161	532 43 99-29	Ventana	354	532 44 86-19	Soporte
162	532 14 24-32	Tornillo 1/4 x 1/2	355	532 44 86-36	Mecanismo
165	532 19 43-30	Soporte	356	532 44 86-93	Acoplamiento
175	532 19 63-04	Travesaño	357	532 44 86-84	Resorte
176	532 40 07-76	Tornillo 10-24 x 5/8	358	580 36 66-01	Guía
177	532 19 52-28	Buje de soporte del guardabarros de carga	359	584 39 34-01	Accionador
179	532 16 89-37	Tuerca de presión	360	532 44 86-18	Soporte del accionador
180	532 44 55-59	Chasis	361	817 49 06-10	Tornillo 3/8-16 x 5/8
182	532 40 68-59	Tablero	362	532 44 86-33	Clavija .375 x 2.42
183	874 52 05-20	Perno 5/16-18 x 1-1/4	365	532 44 73-68	Separador .375 x .4375L
189	817 00 05-12	Tornillo 5/16-18 x 3/4	375	586 90 82-01	Cubierta Capota
191	532 43 74-55	Parrilla reflector (LD)	- -	532 43 18-82	Kit del protector del cepillo
194	873 90 05-00	Tuerca 5/16-18			
196	532 43 96-74	Ensamble de la consola de la plataforma de elevación			
199	532 19 82-59	Plataforma de elevación			
202	532 43 97-28	Salida de Ventilación (LD)			

NOTA: Las dimensiones de todos los componentes están expresadas en pulgadas americanas. 1 pulgada = 25,4 mm

TRACTOR MODELO NO. GT48DXLS (96043023100), PRODUCTO NO. 960 43 02-31
TRANSMISIÓN

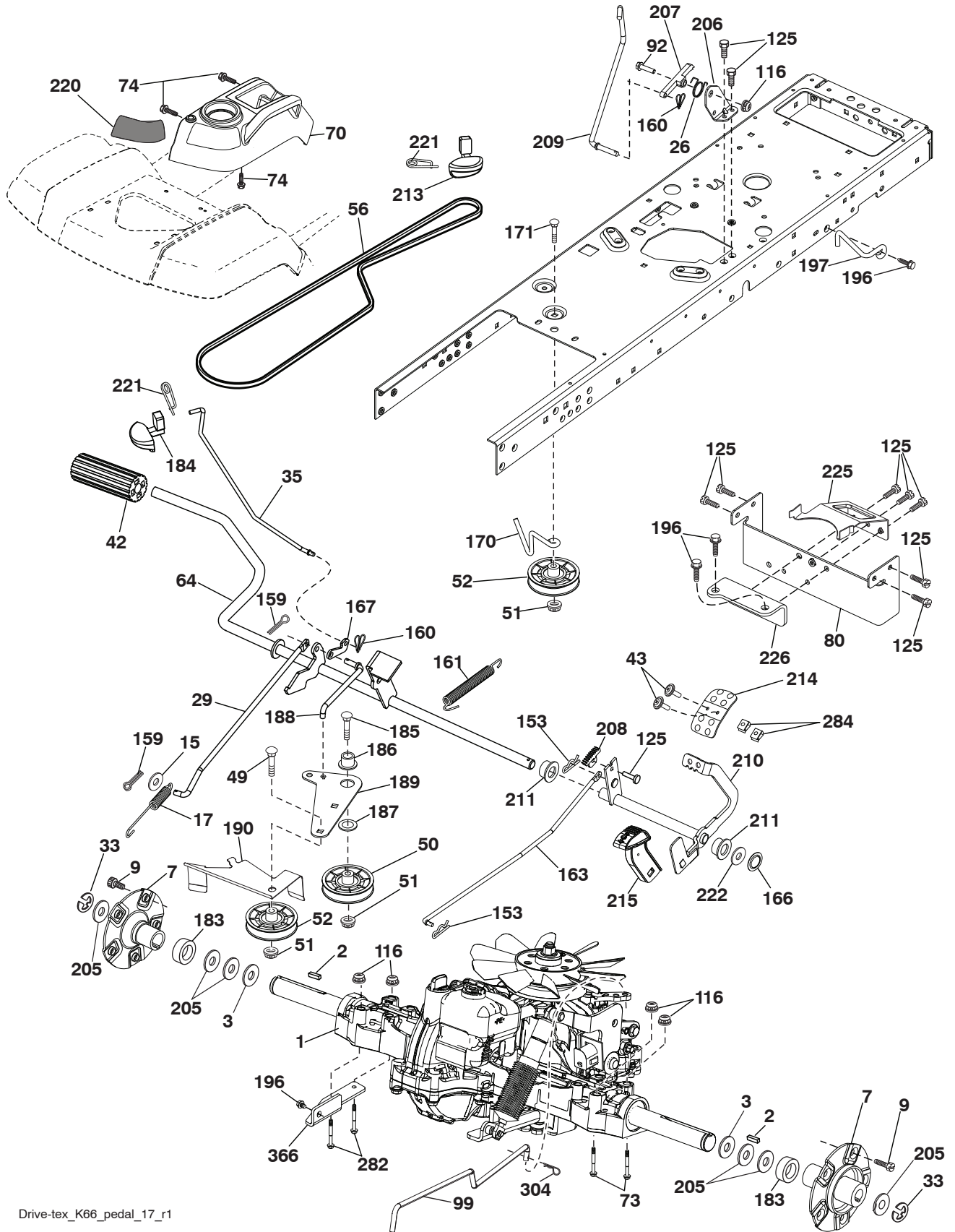

Drive-tex_K66_pedal_17_r1

TRACTOR MODELO NO. GT48DXLS (96043023100), PRODUCTO NO. 960 43 02-31

TRANSMISIÓN

CÓDIGO PIEZA			CÓDIGO PIEZA		
No.	No.	DESCRIPCIÓN	No.	No.	DESCRIPCIÓN
1	---	Transeje, Tufftorq K66ELD (580402201) (Haga el pedido de las piezas al fabricante del transeje.)	183	501 05 15-01	Separador del eje
2	539 91 27-57	Cuña .25 x 1.25	184	587 65 37-01	Manija del freno de mano
3	532 00 75-63	Arandela	185	872 11 06-22	Perno 3/8-16 unc x 2-3/4 grado 5
7	586 93 54-02	Ruede eje la asamblea	186	532 19 43-21	Espaciador de retención
9	532 14 00-80	Perno	187	819 13 32-10	Arandela
15	819 13 13-16	Arandela 13/32 x 13/16 x calibre 16	188	582 21 70-01	Mecanismo de desplazamiento de la varilla de mando del embrague
17	532 40 10-72	Resorte de freno	189	532 19 43-17	Palanca acodada del mecanismo de desplazamiento
26	532 19 96-79	Crucero con retorno de muelle	190	532 19 43-18	Sujetador de la palanca acodada del mecanismo de desplazamiento
29	532 40 72-45	Varilla del freno	196	817 00 06-16	Tornillo 3/8-16 x 1
33	812 00 00-53	Aro "E"	197	585 65 86-01	Soporte
35	583 86 45-01	Varilla del freno de mano	205	532 12 38-00	Arandela 1-1/32 x 1-5/8 x calibre 16
42	532 12 48-72	Cubierta del pedal	206	532 44 85-96	Soporte
43	874 18 04-12	Tornillo 1/4-20 x 3/4	207	587 03 14-01	Bloqueo del control del crucero
49	872 11 06-14	Perno	208	532 19 78-69	Engranaje del sector de control del crucero
50	532 19 43-27	Polea loca plana	209	532 19 95-92	Varilla de control del crucero
51	873 90 06-00	Tuerca 3/8-16	210	532 19 78-60	Ensamble del balancín del control del pedal
52	532 19 43-26	Polea loca con ranura en V con un desplazamiento	211	532 12 01-83	Rodamiento de nylon
56	532 12 59-07	Correa trapezoidal de la transmisión	213	532 40 31-19	Perilla de control del crucero
64	532 19 78-65	Ensamble del eje control del pedal de freno	214	532 41 68-63	Forro del pedal para avanzar
70	532 43 96-61	Ensamble del console	215	586 60 65-02	Forro del pedal para retroceder
73	874 49 05-44	Perno 5/16-18 x 3 Gr. 5	220	532 19 89-08	Reflector (LD)
74	532 14 24-32	Tornillo 1/4 x 1/2	221	532 40 31-87	Abrazadera de retención del resorte de la manija
80	583 97 07-01	Correa de torsión	222	879 21 20-10	Arandela 21/32 x 1-1/4 x calibre 10
92	874 76 05-20	Perno 5/16-18 x 1/2	225	532 40 73-11	Sujetador de la correa
99	582 40 47-01	Resorte	226	532 40 71-09	Soporte de montaje
116	873 90 05-00	Tuerca 5/16-18	282	874 49 05-48	Perno 5/16-18 x 3.0 Gr 5
125	817 00 05-12	Tornillo 5/16-18 x 3/4	284	532 41 76-93	Tuerca 1/4-20
153	532 12 47-88	Retén del resorte	304	532 42 33-03	Pasador de chaveta
159	876 02 04-12	Pasador de chaveta de 1/8 x 3/4	366	580 62 62-01	Soporte
160	532 16 94-84	Abrazadera de retención			
161	532 10 57-09	Resorte de retorno del embrague			
163	532 40 72-46	Varilla de control del pedal			
166	532 42 91-64	Tuerca .625			
167	532 40 52-57	Pestillo del freno de mano			
170	532 19 43-22	Sujetador de la correa			
171	872 11 06-16	Sujetador de la correa			

NOTA: Las dimensiones de todos los componentes están expresadas en pulgadas americanas. 1 pulgada = 25,4 mm

TRACTOR MODELO NO. GT48DXLS (96043023100), PRODUCTO NO. 960 43 02-31
MOTOR

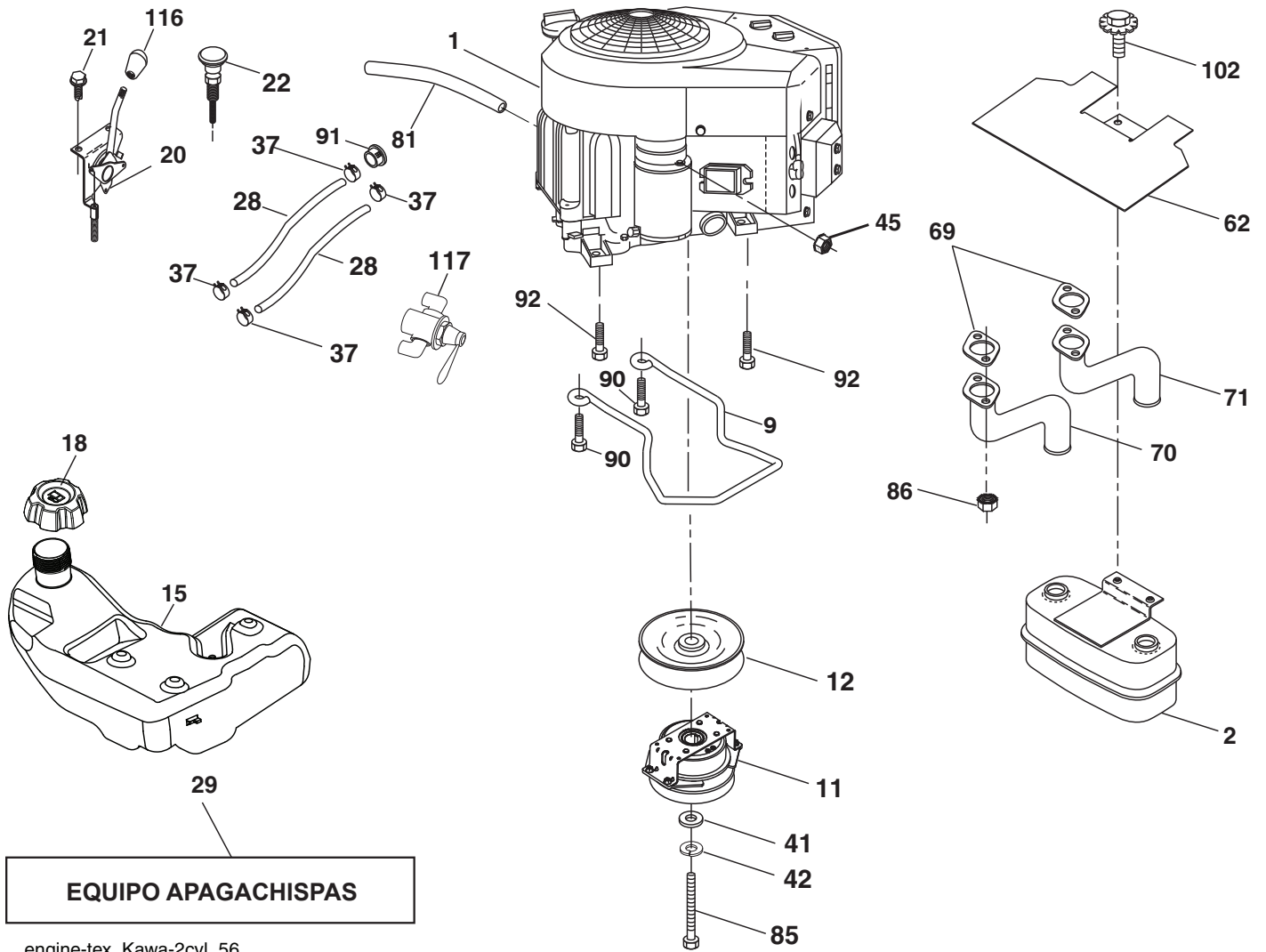

**TRACTOR MODELO NO. GT48DXLS (96043023100), PRODUCTO NO. 960 43 02-31
MOTOR**

CÓDIGO No.	PIEZA No.	DESCRIPCIÓN
1	---	Motor KAWA modelo No. FR730V-ES04 (445363)(Haga el pedido de las piezas al fabricante del motor.)
2	532 44 59-62	Silenciador
9	501 83 26-01	Ensamble del sujetador de la correa del motor
11	587 24 14-01	Embrague de eléctrico
12	532 19 43-43	Polea del motor
15	532 43 80-82	Tanque de Gasolina de 4,0 R
18	585 12 48-01	Tapa
20	532 42 43-41	Control del regulador
21	532 41 63-58	Tornillo No. 10 x 0,75 con rosca reforzada
22	532 19 15-96	Control de la estrangulación del motor
28	532 40 11-35	Línea de combustible
29	532 13 71-80	Equipo apagachispas
37	532 12 34-87	Abrazadera de la manguera
41	532 12 61-97	Arandela 1-1/2 x 15/32 x .250
42	810 04 07-00	Arandela de presión de 7/16
45	873 51 04-00	Tuerca
62	532 14 66-29	Silenciador con pantalla térmica
69	532 17 81-51	Junta
70	583 95 56-01	Tubo de escape izquierdo
71	583 95 57-01	Tubo de escape derecho
81	532 14 84-56	Tubo de drenaje
85	501 60 69-01	Perno de 7/16-20 x 3.0 x grado 5
86	532 18 43-62	Tuerca
90	817 00 06-16	Tornillo de 3/8-16 x 1
91	532 18 74-95	Buje
92	817 12 06-16	Tornillo 3/8-16 x 1
102	817 00 05-12	Tornillo 5/16-18 x 3/4
116	539 13 26-24	Tacto suave de la perilla
117	532 42 08-28	válvula de la reserva del combustible

NOTA: Las dimensiones de todos los componentes están expresadas en pulgadas americanas. 1 pulgada = 25,4 mm
Para las piezas del servicio y de recambio del motor, llame el número gratis para su fabricante del motor enumerado abajo:
Kawasaki 1-949-460-5688

TRACTOR MODELO NO. GT48DXLS (96043023100), PRODUCTO NO. 960 43 02-31
ENSAMBLE DE LA DIRECCIÓN

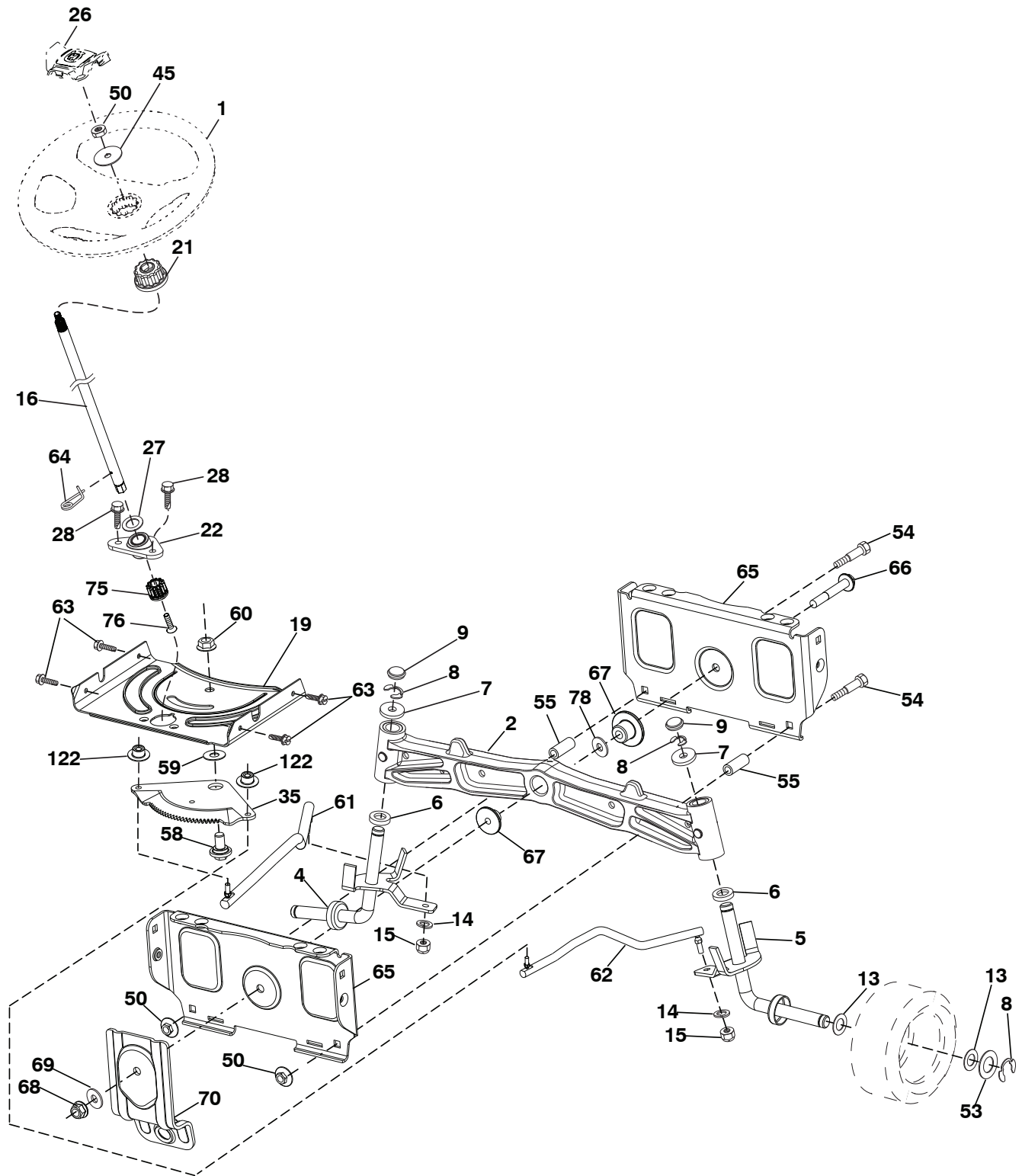

steering-tex_HUSQSR_63

**TRACTOR MODELO NO. GT48DXLS (96043023100), PRODUCTO NO. 960 43 02-31
ENSAMBLE DE LA DIRECCIÓN**

CÓDIGO No.	PIEZA No.	DESCRIPCIÓN
1	532 43 97-40	Volante de dirección
2	532 19 59-68	Ensamble del eje delantero
4	532 40 30-89	Ensamble del husillo izquierdo
5	532 40 30-90	Ensamble del husillo derecho
6	532 12 49-31	Pista del rodamiento para reforzar el impulso
7	532 12 17-48	Arandela de 25/32 x 1-5/8 calibre 16
8	812 00 00-29	Abrazadera del aro No. T5304-75
9	532 12 12-32	Tapa del husillo
13	532 12 17-49	Arandela de 25/32 x 1-1/4 calibre 16
14	810 04 06-00	Arandela de presión de 3/8
15	873 54 06-00	Tuerca de 3/8-24 unf
16	587 01 60-02	Eje de dirección
19	532 19 47-29	Placa de dirección
21	586 84 02-01	Adaptador del volante de dirección
22	585 02 98-02	Rodamiento
26	532 43 97-43	Inserto del volante de dirección
27	819 21 16-16	Arandela
28	817 00 06-12	Tornillo de 3/8-16 x 3/4
35	532 19 47-32	Engranaje del sector de la placa
45	587 01 64-01	Arandela 3/8 ID 2-3/8 OD calibre 12 PLTD
50	873 90 06-00	Tuerca 3/8-16 unc
53	532 18 89-67	Arandela reforzada de, 793 x 1,637 x 0,060
54	874 76 06-36	Tornillo 3/8-16 unc x 2-1/4
55	532 41 47-36	Tornillo 3/8-16 unc x 2-1/4
58	532 19 47-47	Perno de tope del sector del pivote CFM
59	532 19 47-48	Arandela de empuje del sector de dirección
60	873 97 10-00	Tuerca de 5/8-11
61	532 19 47-40	Barra de acoplamiento izquierda
62	532 19 47-41	Barra de acoplamiento derecha
63	817 00 05-12	Tornillo de 5/16-18 x 3/4
64	532 19 98-49	Abrazadera de retención del resorte de la dirección
65	532 19 47-34	Apoyo del árbol delantero
66	871 02 07-48	Perno de cabeza hexagonal con brida acanalada de 7/16-14 x 3
67	532 19 47-37	Buje PM del eje delantero
68	873 90 07-00	Tuerca de 7/16-14 grado 5
69	532 19 91-62	Arandela de 1,5 x 0,505 x 0,118
70	585 33 88-01	Soporte de la plataforma delantera
75	580 68 37-01	Piñón
76	580 68 36-01	Tornillo
78	532 05 70-79	Tuerca
122	532 44 49-62	Tapa

NOTA: Las dimensiones de todos los componentes están expresadas en pulgadas americanas. 1 pulgada = 25,4 mm

**TRACTOR MODELO NO. GT48DXLS (96043023100), PRODUCTO NO. 960 43 02-31
PLATAFORMA DE LA CORTADORA DE CÉSPED**

CÓDIGO PIEZA			CÓDIGO PIEZA		
NO.	NO.	DESCRIPCIÓN	NO.	NO.	DESCRIPCIÓN
1	588 78 80-02	Cubierta	57	587 35 84-01	Resorte
2	539 13 18-98	Ensamble de la cubierta	58	532 11 04-85	Rodamiento de bolitas
3	532 18 76-90	Arandela	61	532 40 03-37	Varilla
4	532 17 34-34	Polea	62	819 13 13-12	Arandela 13/32 x 13/16 x calibre 12
5	532 40 02-34	Tuerca	63	817 49 04-10	Tornillo 1/4-20 x 5/8
7	588 98 07-01	Deflector	64	584 95 39-01	Perno .313-18 x 1.19
8	587 35 47-01	Resorte - torsión	67	532 19 61-06	Polea
10	588 81 10-02	Cuchilla	68	817 49 06-28	Tornillo 3/8-16 x 1-3/4 TT
11	532 19 30-03	Perno, 7/16-20	69	532 19 65-39	Perno
15	532 19 51-61	Sujetador del perno prisionero	70	532 13 14-91	Varilla
16	539 11 28-99	Tuerca	71	532 11 04-52	Tuerca
17	532 19 61-04	Polea más ociosa	73	588 81 24-02	Cubierta del mandril lado derecho
18	588 81 23-02	Brazo más ocioso	74	532 13 77-29	Tornillo 1/4-20 x 5/8
19	532 19 31-97	Polea más ociosa	75	588 81 31-02	Cubierta del mandril lado izquierdo
22	532 17 48-73	Rueda, calibrador	76	582 54 11-01	Guarnición
23	532 19 34-06	Perno 3/8-16 x 3-5/8	77	582 36 05-01	Buje
24	521 99 65-01	Tuerca 3/8-16	79	872 11 06-14	Perno 3/8-16 unc x 1-3/4 Gr. 5
26	588 43 83-01	Tornillo 7/16-14 x 2.125	80	532 17 01-65	Perno 5/16
31	873 90 06-00	Tuerca 3/8-16	81	532 10 53-04	Tapa
34	532 17 85-15	Arandela	--	532 41 64-05	Accesorio del conexión
36	532 19 51-85	Suspensión posterior del brazo	--	589 42 88-01	Cubierta del cortacéspedes completa
39	873 90 05-00	Tuerca 5/16-18			
40	532 17 60-66	Rodillo de la nariz			
41	532 17 91-27	Varilla, rodillo de la nariz			
42	532 19 42-08	Pasador de chaveta			
50	532 41 55-98	Puerto del derrubio			
53	588 81 43-01	Correa, cubierta			
54	532 14 10-43	Protector, correa			
55	539 11 55-74	Perno de argolla 5/16 x 3-1/2			
56	539 99 05-85	Tuerca 5/16-18			

NOTA: Las dimensiones de todos los componentes están expresadas en pulgadas americanas. 1 pulgada = 25,4 mm

TRACTOR MODELO NO. GT48DXLS (96043023100), PRODUCTO NO. 960 43 02-31
ELEVACIÓN DE LA CORTADORA DE CÉSPED

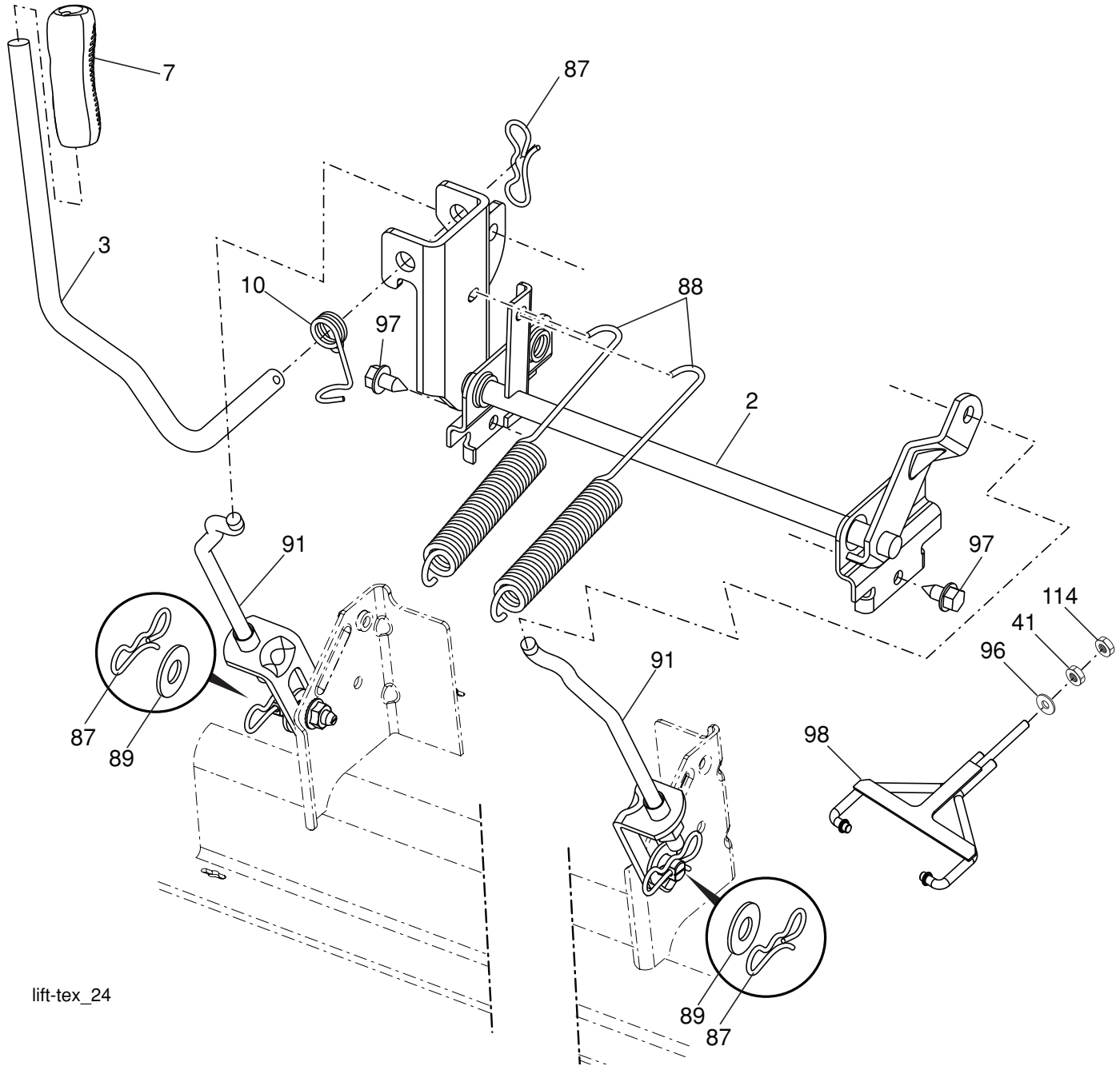

lift-tex_24

CÓDIGO No.	PIEZA No.	DESCRIPCIÓN
2	532 42 20-27	Ensamble del eje de la elevación
3	532 19 52-30	Ensamble de la palanca de elevación derecha
7	580 96 23-01	Mango de la palanca
10	532 19 63-14	Resorte de torsión
41	532 17 59-94	Tuerca
87	532 19 42-09	Pasador de chaveta de 7/16 con bloqueo en forma de mariposa
88	532 19 53-04	Resorte de ayuda de la elevación
89	819 19 19-12	Arandela de zinc transparente

CÓDIGO No.	PIEZA No.	DESCRIPCIÓN
91	532 40 34-07	Ensamble del acoplamiento Elevación trasera
96	532 19 52-63	Buje
97	817 00 06-12	Tornillo de 3/8-16 x 0,75
98	574 82 25-01	Acoplamiento frontal de la elevación de la cortadora de césped
114	873 36 07-00	Tuerca 7/16-20

NOTA: Las dimensiones de todos los componentes están expresadas en pulgadas americanas. 1 pulgada = 25,4 mm

**TRACTOR MODELO NO. GT48DXLS (96043023100), PRODUCTO NO. 960 43 02-31
ENSAMBLE DEL ASIENTO**

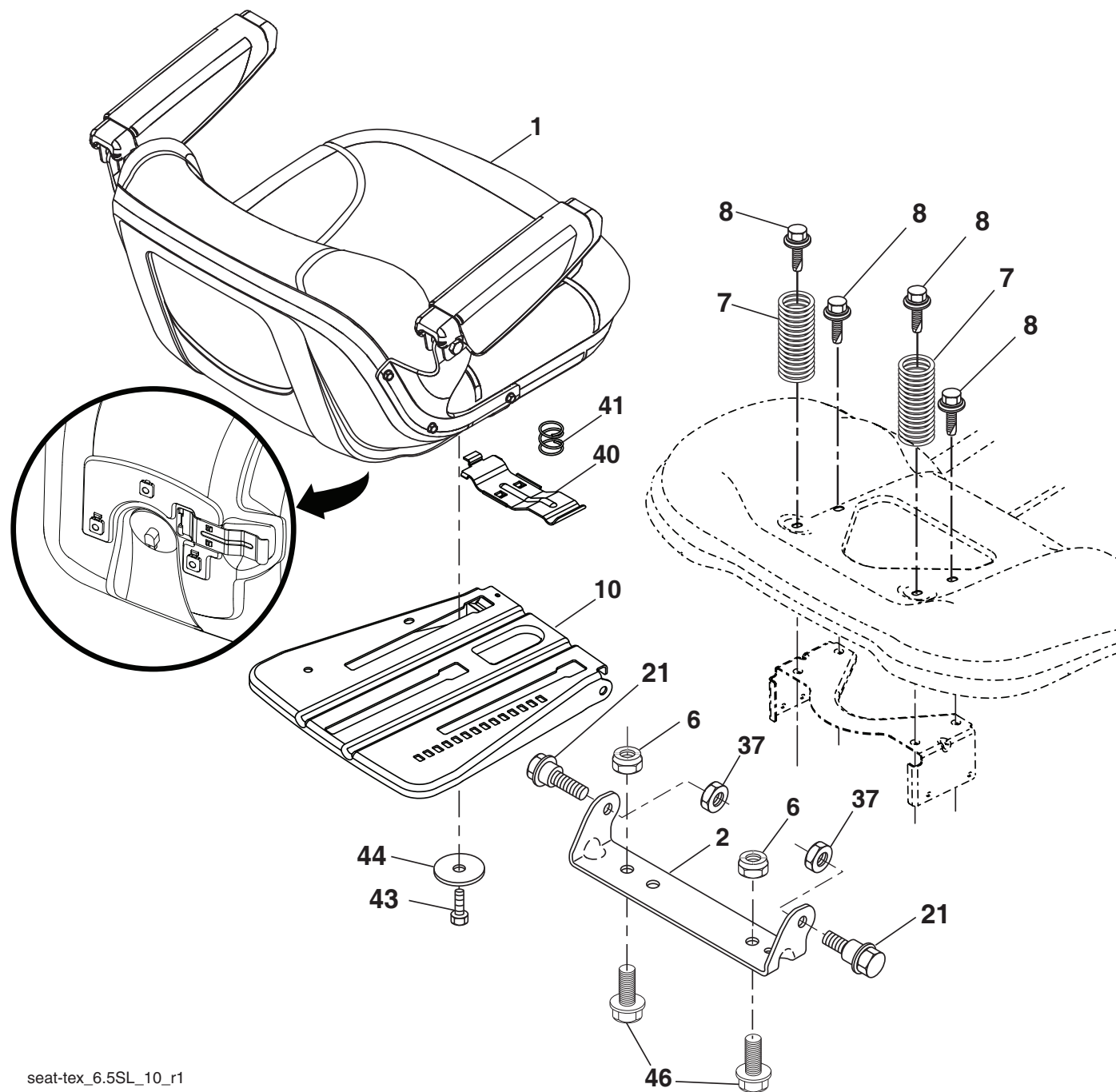

seat-tex_6.5SL_10_r1

CÓDIGO No.	PIEZA No.	DESCRIPCIÓN
1	532 44 32-63	Asiento
2	532 18 01-66	Soporte pivotante del guardabarros
6	873 80 06-00	Tuerca de presión c/aislamiento de 3/8-16 unc
7	587 61 33-01	Resorte del asiento
8	532 17 18-77	Perno de 5/16" unc x 3/4"
10	532 19 69-77	Bandeja del asiento
21	587 90 78-01	Perno de tope de 5/16-18 x 5/8
37	873 80 05-00	Tuerca de presión de 5/16-18 unc
40	532 19 76-61	Manija para deslizar el asiento

CÓDIGO No.	PIEZA No.	DESCRIPCIÓN
41	532 19 82-00	Resorte para trabar el asiento
43	874 76 06-12	Perno de cabeza hexagonal con aleta de 3/8-16 unc x 3/4
44	819 13 38-12	Arandela de 13/32 x 2-3/8 calibre 12
46	588 09 04-01	Perno 3/8-16 x 1, 1.25

NOTA: Las dimensiones de todos los componentes están expresadas en pulgadas americanas. 1 pulgada = 25,4 mm

TRACTOR MODELO NO. GT48DXLS (96043023100), PRODUCTO NO. 960 43 02-31

CALCOMANÍAS

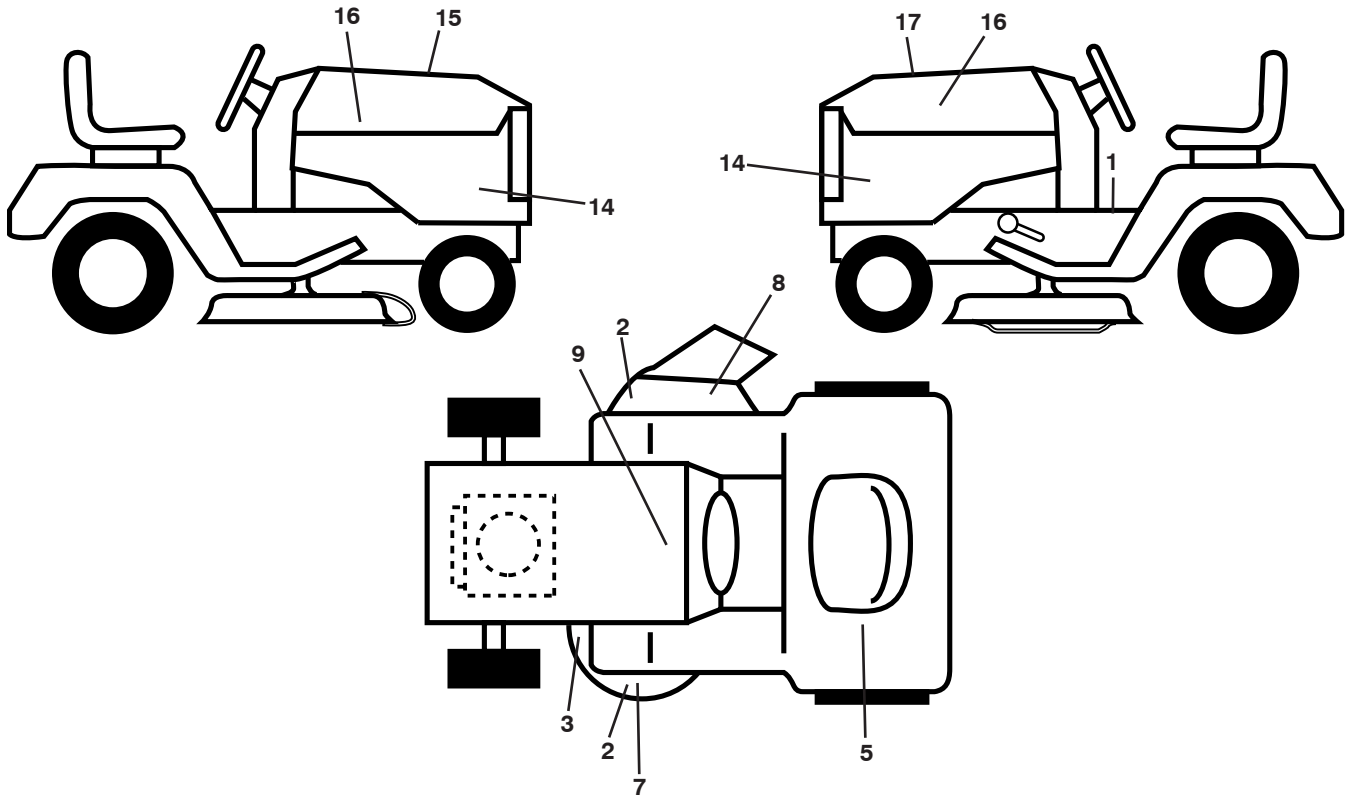

CÓDIGO No.	PIEZA No.	DESCRIPCIÓN
1	581 57 89-01	Calcomanía, Advertencia
2	589 35 79-01	Calcomanía, Ningún paso
3	539 11 26-20	Calcomanía del diagrama de la cortadora de césped
5	587 01 51-01	Calcomanía, Cuidado
7	532 44 81-21	Calcomanía, Cubierta
8	586 97 88-01	Calcomanía, Advertencia
9	532 14 50-05	Calcomanía de Peligro/Punto de interconexión
14	589 65 54-01	Calcomanía, Panel
15	532 42 38-29	Calcomanía

CÓDIGO No.	PIEZA No.	DESCRIPCIÓN
16	581 62 73-01	Calcomanía para la capota, logo
17	589 62 66-01	Calcomanía de reemplazo
--	581 72 48-01	Calcomanía para la desviación
--	532 43 98-82	Forro del apoyo para los pies izquierdo
--	532 43 98-81	Forro del apoyo para los pies derecho
--	115 86 32-26	Manual del operario (Inglés/Español)
--	115 86 33-26	Manual de repuestos (Inglés/Español)
--	587 71 00-26	Manual de QSG (Inglés/Español)

WHEELS AND TIRES

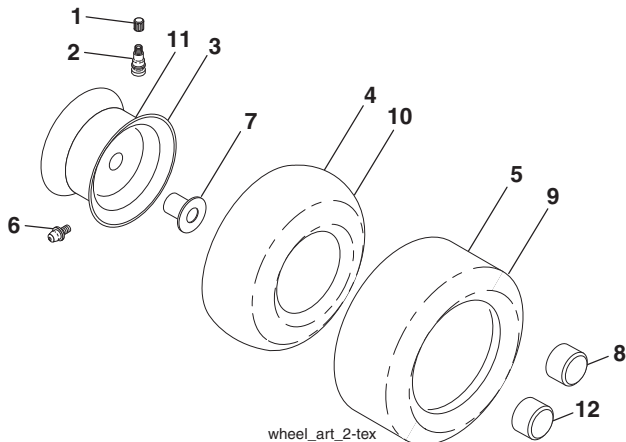

wheel_art_2-tex

CÓDIGO No.	PIEZA No.	DESCRIPCIÓN
1	532 05 91-92	Tapa de la válvula del neumático
2	532 06 51-39	Vástago de la válvula
3	532 18 18-39	Ensamble de las llantas delanteras
4	532 00 81-34	Cámara delantera
5	532 16 10-24	Neumático delantero 16 x 6.5-8
6	532 12 49-57	Accesorio para engrasar (solo para la rueda delantera)
7	532 12 49-59	Rodamiento de la brida (solo para la rueda delantera)
8	532 17 50-39	Tapa del eje frente
9	532 17 04-53	Neumático trasero 23 x 10.5-12
10	532 00 71-54	Cámara trasera (Mantenimiento sólo)
11	532 14 45-10	Ensamble trasero de la llanta
12	501 50 31-01	Tapa del eje trasero negro
--	532 14 43-34	Sellador para neumáticos (tubo de 10 onzas [283 gr])

NOTA: Las dimensiones de todos los componentes están expresadas en pulgadas americanas. 1 pulgada = 25,4 mm

NOTES/AVISO

02/21/2017 CL