

ILLUSTRATED PARTS LIST

MFG. ID NO. 96041042300

CUSTOMER CATALOG NO. TS 343

PRODUCT NO. 960 41 04-23

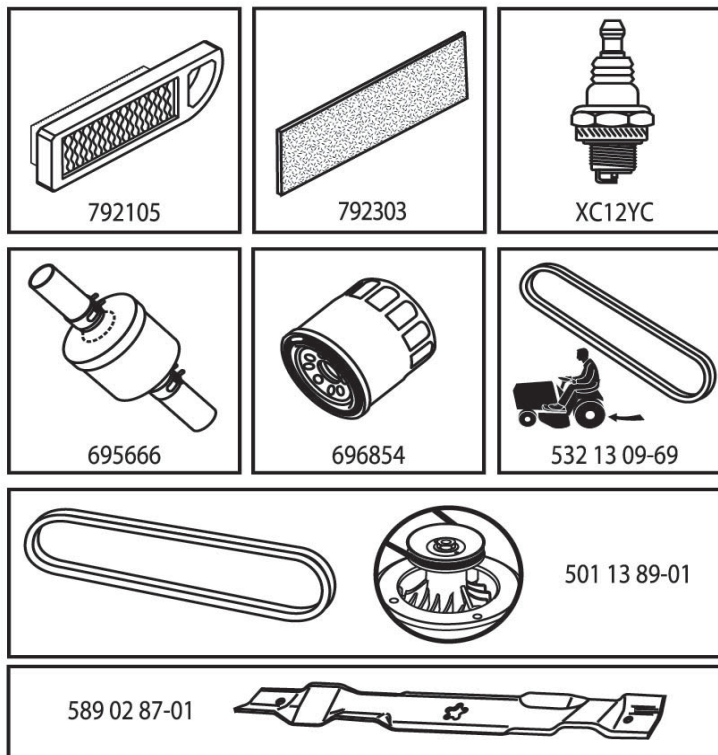

47

588896801

**TRACTOR - - MODEL NO. TS 343 (96041042300), PRODUCT NO. 960 41 04-23
DECALS 27**

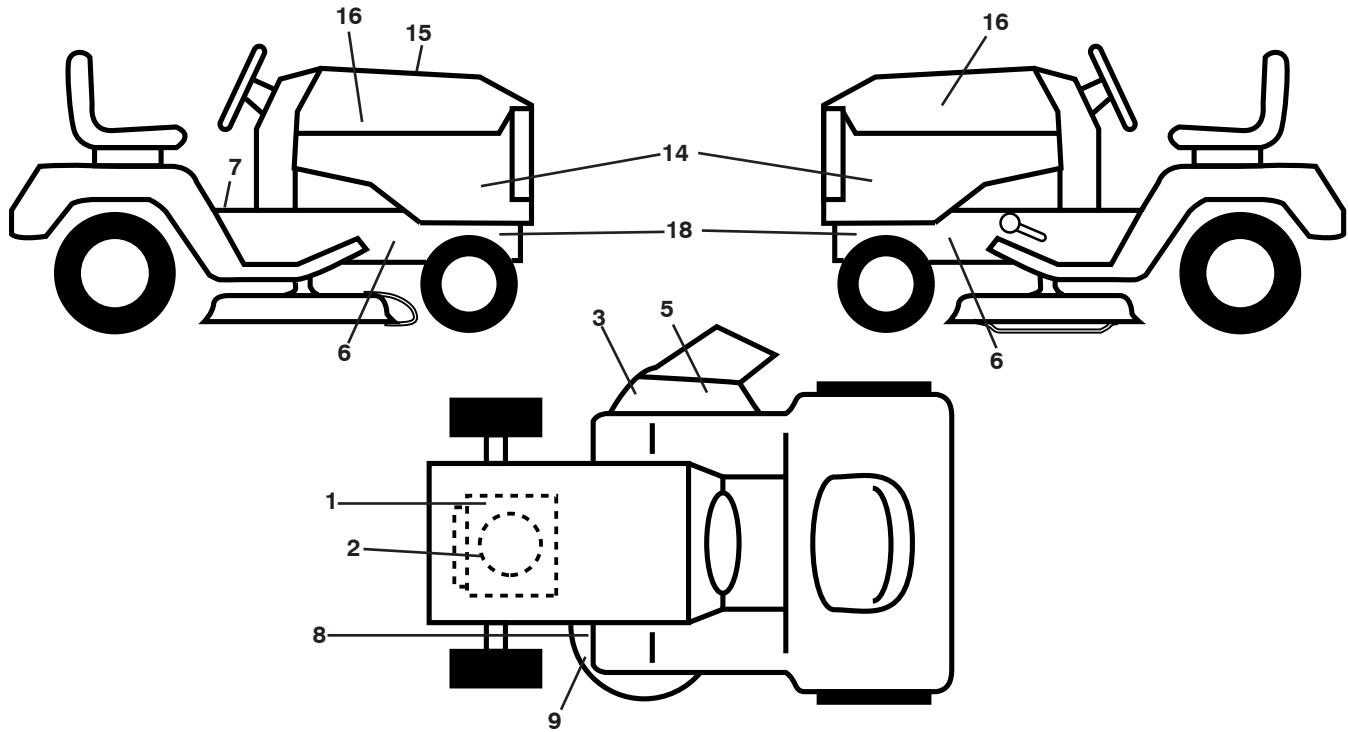

KEY NO.	PART NO.	DESCRIPTION
1	581 57 97-01	Decal, Engine Warning
2	594 72 71-01	Decal, Engine
3	590 88 49-01	Decal, 42" Deck
5	586 97 88-01	Decal, Deflect. Warning
6	581 57 98-01	Decal, Warning
7	586 04 73-02	Decal, Warning Symbols
8	581 58 00-01	Decal, Mower Sch.
9	589 35 79-01	Decal, Deck No Step
14	588 90 11-01	Decal, Panel Side
15	588 89 68-01	Decal, Replacement Parts
16	581 62 73-01	Decal, Hood Logo

KEY NO.	PART NO.	DESCRIPTION
18	581 57 96-01	Decal, Chassis Hot Muffler
--	581 72 46-01	Decal, Drawbar Load Limit
--	581 72 48-01	Decal, Bypass
--	501 74 90-01	Decal, Drawbar, Locking Diff.
--	532 43 98-82	Pad, Footrest, LH
--	532 43 98-81	Pad, Footrest, RH
--	114 05 10-20	Manual, Operator's (Euro)
--	114 05 11-10	Manual, Operator's (Scan)
--	114 05 09-50	Manual, Operator's (E-bloc)
--	114 05 08-40	Manual, Operator's (Baltic)

WHEELS AND TIRES

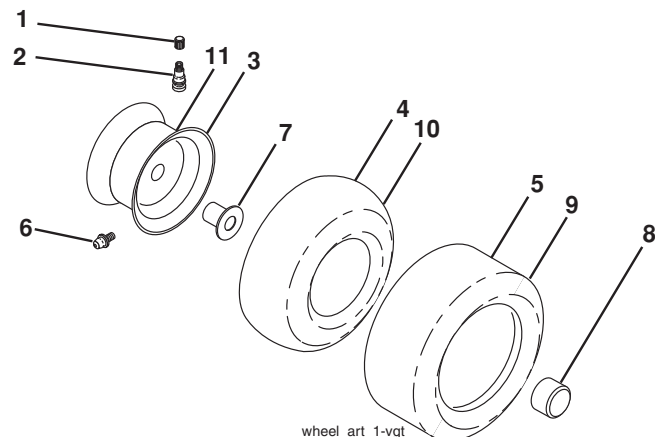

KEY NO.	PART NO.	DESCRIPTION
1	532 05 91-92	Cap, Valve, Tire
2	532 06 51-39	Stem, Valve
3	532 13 83-36	Rim Assembly, Front
4	532 05 99-04	Tube, Front (Service Item Only)
5	532 17 04-55	Tire, Front 15 x 6-6
6	532 12 49-57	Fitting, Grease (Front Wheel Only)
7	532 12 49-59	Bearing, Flange (Front Wheel Only)
8	532 17 50-39	Cap, Axle (Front Wheel Only)
9	532 17 04-56	Tire, Rear 20 x 10-8
10	532 00 71-52	Tube, Rear (Service Item Only)
11	532 13 83-37	Rim Assembly, Rear
--	532 14 43-34	Sealant, Tire (10 oz. Tube)

NOTE: All component dimensions given in U.S. inches
1 inch = 25.4 mm

TRACTOR - - MODEL NO. TS 343 (96041042300), PRODUCT NO. 960 41 04-23 SCHEMATIC 38

SCH12

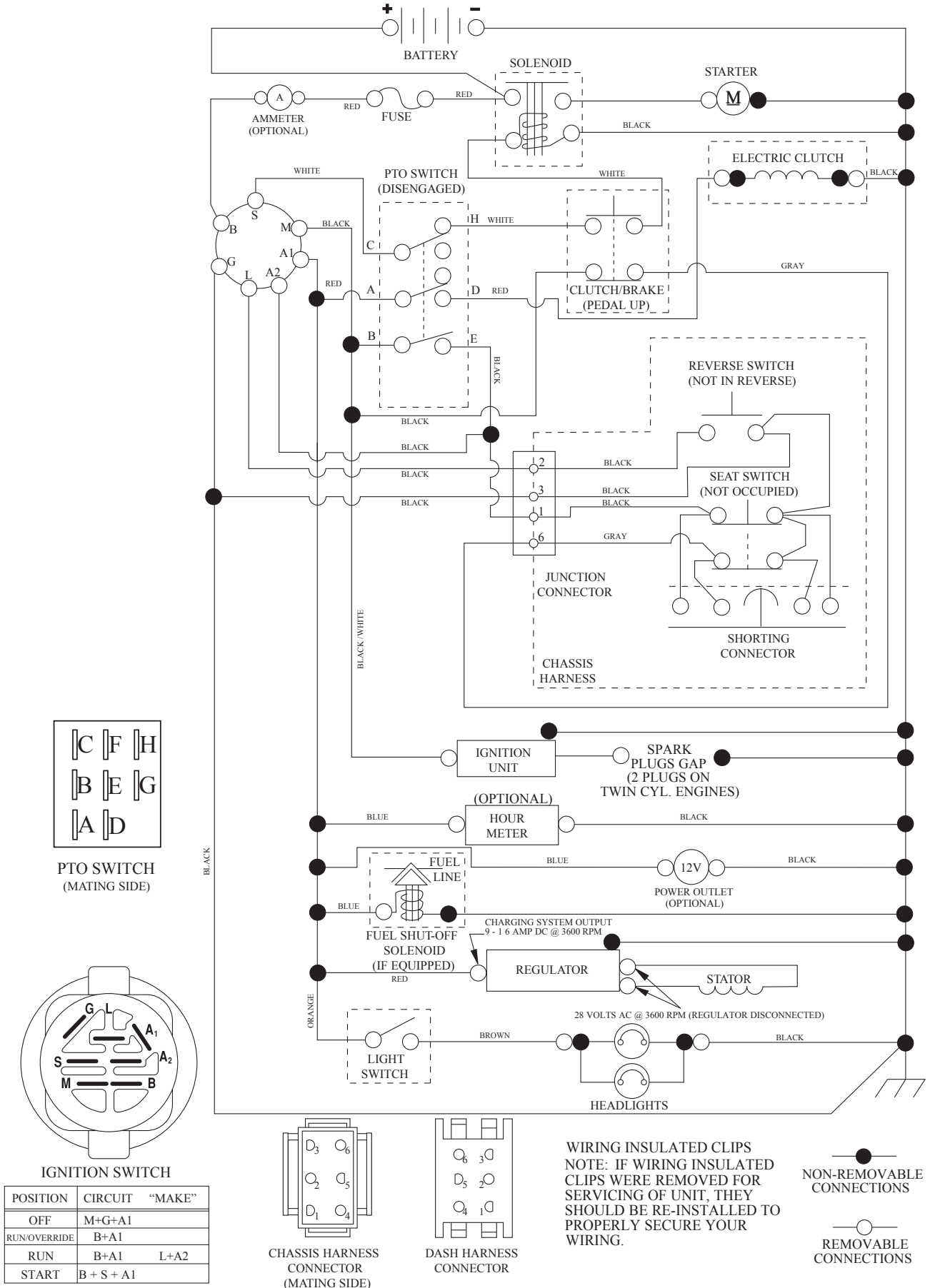

TRACTOR - - MODEL NO. TS 343 (96041042300), PRODUCT NO. 960 41 04-23
ELECTRICAL 32

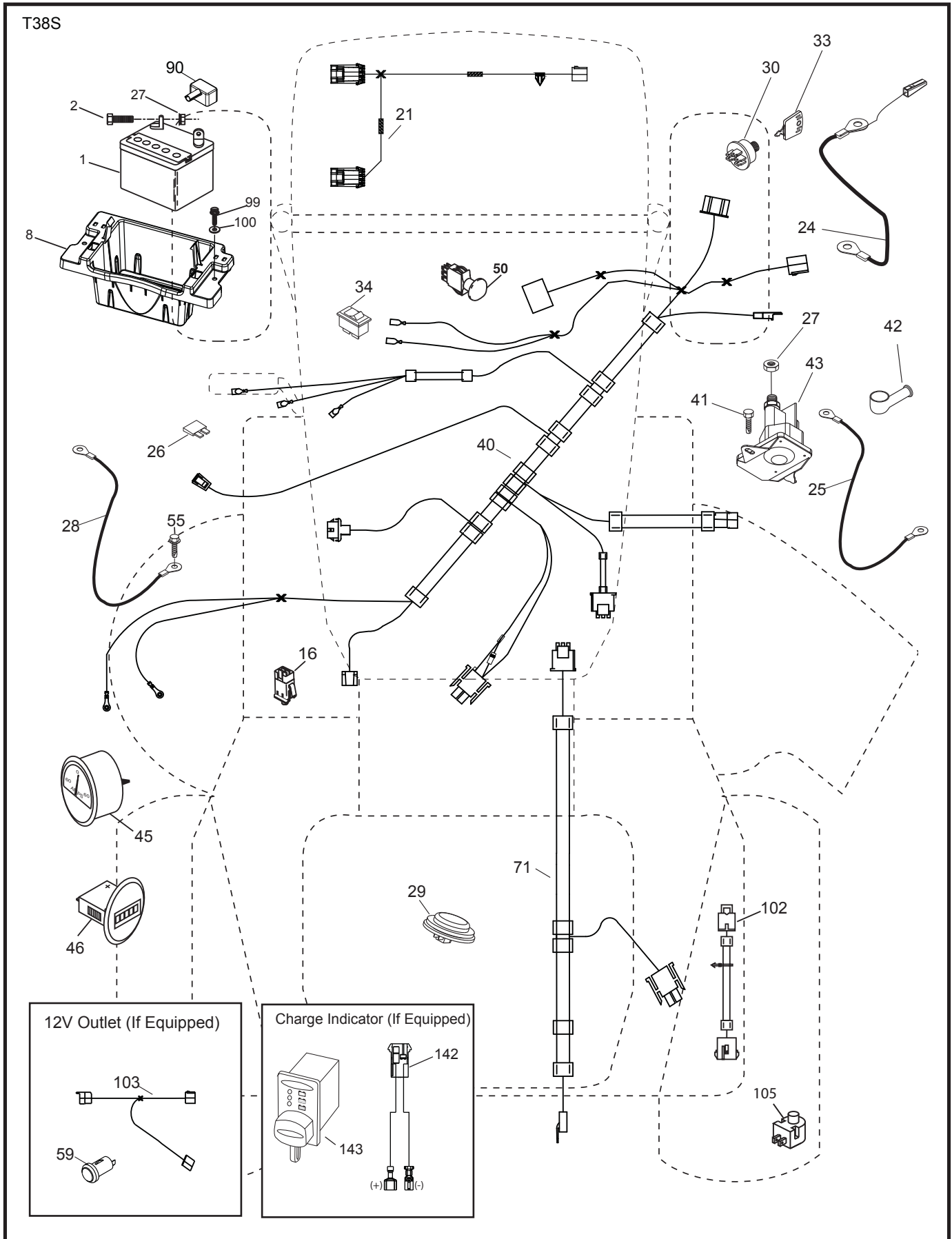

**TRACTOR - - MODEL NO. TS 343 (96041042300), PRODUCT NO. 960 41 04-23
ELECTRICAL 32**

KEY PART NO.	NO.	DESCRIPTION
1	532 16 34-65	Battery
2	874 76 04-12	Bolt Hex Hd. 1/4-20 unc x 3/4
8	587 20 51-01	Battery Box
16	532 17 61-38	Switch Interlock
21	585 43 64-01	Harness Light
24	585 55 56-01	Cable Battery
25	585 55 55-01	Cable Starter
26	532 17 51-58	Fuse
27	873 51 04 00	Nut Keps Hex 1/4-20 unc
28	532 41 65-88	Cable Ground
29	532 40 15-45	Switch Seat
30	532 19 33-50	Switch Asm. Smart
33	532 41 19-33	Key/Chain
34	532 11 07-12	Switch, Light
40	532 42 90-83	Harness Ign. Dash
41	817 72 04-08	Screw 1/4-20 x 1/2
42	532 13 15-63	Cover Terminal
43	582 04 28-01	Solenoid
45	587 55 39-03	Ammeter Guage Round
46	587 55 40-03	Hourmeter Gauge
50	582 10 76-01	Switch PTO
55	817 06 05-12	Screw 5/16-18 x 3/4
71	532 19 42-76	Harness Ign. Chassis
90	532 43 53-95	Cover Terminal Battery
99	817 67 04-12	Screw Hex Wsh. Thdrol. 1/4-20 x 3/4
100	819 09 14-16	Washer 9/32 x 7/8 x 16 Ga.
102	532 40 44-54	Harness Pigtail Tex ROS Tufftorq
105	532 40 75-68	Switch Reverse
142	583 85 78-01	Charge Port Pigtail
143	532 44 80-59	Charge Port

NOTE: All component dimensions given in U.S. inches
1 inch = 25.4 mm

TRACTOR - - MODEL NO. TS 343 (96041042300), PRODUCT NO. 960 41 04-23
CHASSIS AND ENCLOSURES **39**

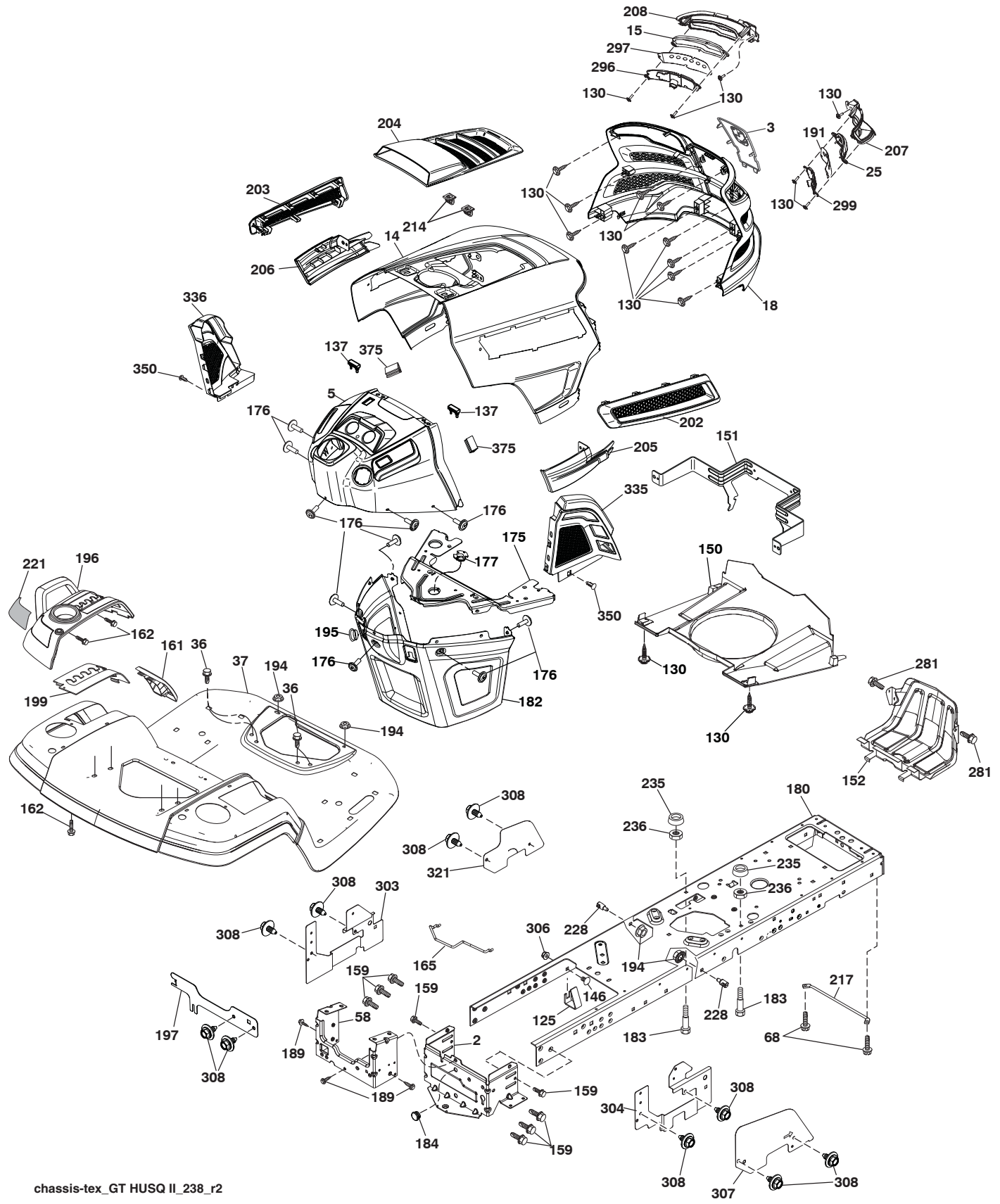

chassis-tex_GT HUSQ II_238_r2

**TRACTOR - - MODEL NO. TS 343 (96041042300), PRODUCT NO. 960 41 04-23
CHASSIS AND ENCLOSURES 39**

KEY NO.	PART NO.	DESCRIPTION
2	532 41 22-82	Drawbar Lower 2pc
3	532 44 44-81	Applique Sub Asm.
5	590 74 00-29	Dash
14	532 44 11-77	Hood
15	585 42 03-01	Lens LH
18	587 52 34-01	Grille
25	585 42 02-01	Lens RH
36	817 06 05-12	Screw 5/16-18 x 3/4
37	532 44 12-08	Fender
58	532 41 22-81	Drawbar Upper
68	539 99 08-58	Screw 5/16-18 x 1/2
125	581 68 48-01	Clip Fuel Line
130	532 41 63-58	Screw #10 x 0.750
137	532 40 75 90	Bumper Dash
146	581 85 79-01	Bolt
150	532 43 97-74	Duct Heat Hood
151	532 43 66-70	Pivot Bracket
152	532 43 98-70	Shield Browning/Debris
159	817 00 06-12	Screw 3/8-16 x 3/4 BL
161	532 43 99-29	Console Fuel Window
162	532 14 24-32	Screw Hex Wsh. Hi-Lo 1/4 x 1/2
165	532 19 43-30	Bracket Support Tank
175	590 60 77-02	Crossmember
176	532 40 07-76	Screw #10-24 x 5/8
177	532 19 52-28	Bushing Steering
180	593 34 63-01	Chassis
182	532 40 68-59	Dash Lower
183	874 52 05-20	Bolt 5/16-18 unc x 1-1/4
184	587 55 41-01	Plug Demo
189	817 00 05-12	Screw 5/16-18 x 3/4
191	586 18 28-01	Insert Reflective RH
194	873 90 05-00	Nut Lock Hex Flange 5/16-18
195	532 40 41-37	Plug 12 V Adapter
196	532 43 97-16	Console Asm. Deck Lift
197	589 20 46-02	Shield Drawbar

KEY NO.	PART NO.	DESCRIPTION
199	532 19 82-59	Plate Deck Lift
202	532 43 97-28	Vent Side Hood RH
203	532 43 97-27	Vent Side Hood LH
204	532 43 57-14	Vent Asm. Hood Top
205	532 43 97-30	Trim Hood Side RH
206	532 43 97-29	Trim Hood Side LH
207	585 42 00-01	Bezel RH
208	585 42 01-01	Bezel LH
214	532 19 91-45	Clip Retainer
217	532 40 91-67	Rod Pivot
221	532 19 89-09	Reflector LH
228	532 19 51-61	Stud Fastener
235	532 40 61 29	Spacer Fender
236	873 93 05-00	Nut 5/16-18 unc
281	817 00 06-16	Screw 3/8-16 x 1
296	585 42 05-01	LED Light LH
297	586 18 29-01	Insert Reflective LH
299	585 42 04-01	LED Light RH
303	589 00 81-02	Shield Lower LH
304	589 00 90-02	Shield Lower RH
306	873 90 06-00	Nut 3/8-16 unc
307	587 52 03-01	Shield Upper RH
308	532 17 18-77	Bolt 5/16-18 unc x 3/4
321	587 52 02-01	Shield Upper LH
335	532 44 82-04	Lower Dash Cover RH
336	532 44 53-09	Lower Dash Cover LH
350	532 44 51-43	Clip X-mas Tree
375	586 90 82-01	Dash Clip-On Bumper
--	532 43 18-82	Kit Guard Brush
--	586 29 76-01	Plug Light Switch

NOTE: All component dimensions given in U.S. inches
1 inch = 25.4 mm

TRACTOR - - MODEL NO. TS 343 (96041042300), PRODUCT NO. 960 41 04-23
DRIVE **40**

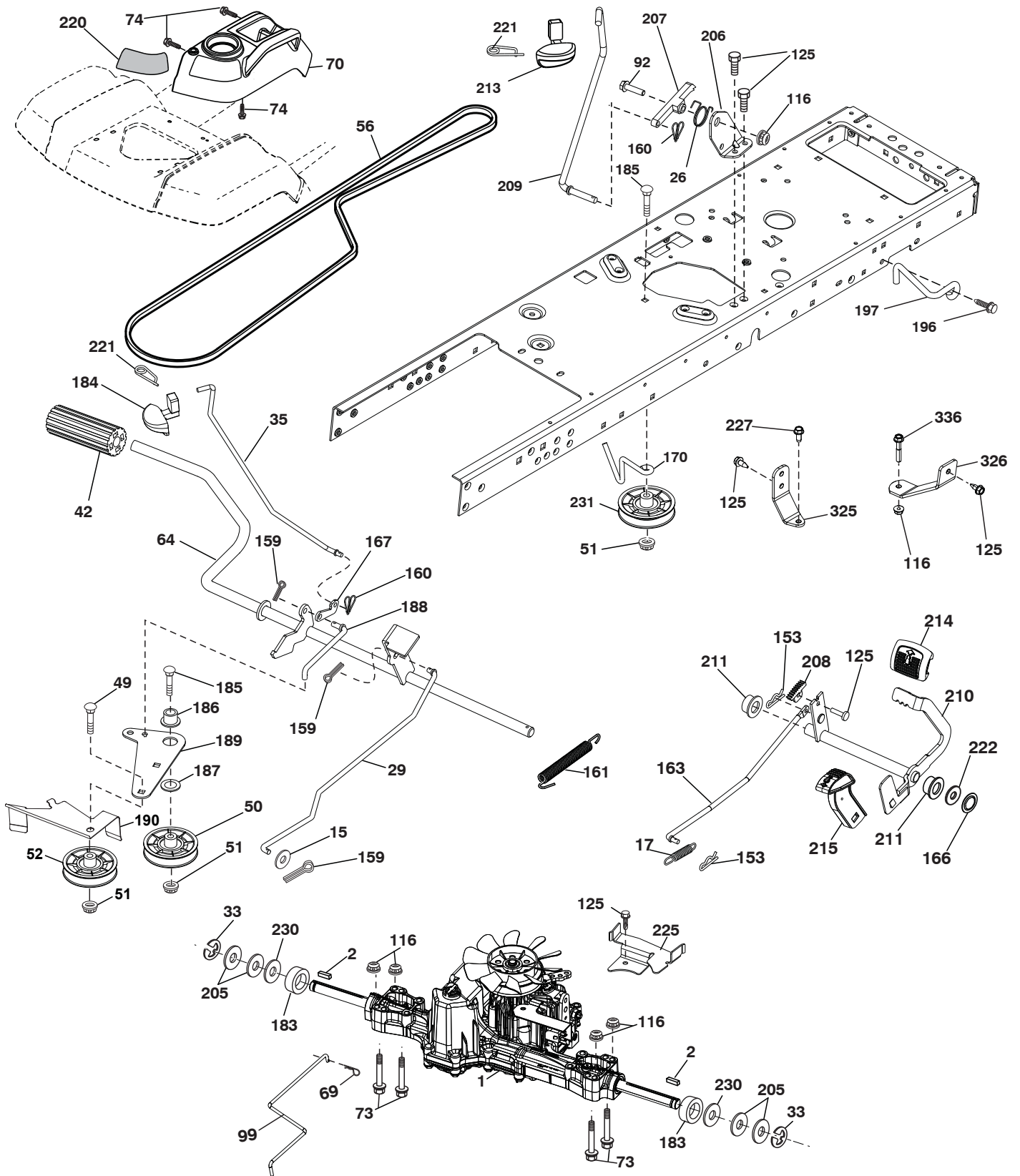

drive-tex_K46_pedal_204_r1

**TRACTOR - - MODEL NO. TS 343 (96041042300), PRODUCT NO. 960 41 04-23
DRIVE **40****

KEY NO.	PART NO.	DESCRIPTION	KEY NO.	PART NO.	DESCRIPTION
1	---	Transaxle, TuffTorq K46LD (501051401) (Order parts from transaxle manufacturer.)	185	872 11 06-22	Bolt
2	532 12 35-83	Key	186	532 19 43-21	Spacer Retainer
15	819 13 13-16	Washer 13/32 x 13/16 x 16 Ga.	187	819 13 32-10	Washer
17	532 41 36-78	Spring, Brake	188	582 21 70-01	Link Clutch Ground Drive, Long
26	532 19 96-79	Spring Return Cruise	189	532 19 43-17	Bellcrank Ground Drive
29	532 40 38-06	Rod, Brake	190	532 19 43-18	Keeper Bellcrank Ground Drive
33	812 00 00-01	Ring E	196	817 00 06-16	Screw 3/8-16 x 1
35	583 86 45-01	Rod, Brake, Park	197	587 40 20-01	Link Clutch Anti-Rotation
42	532 12 48-72	Cover, Foot Pedal	205	532 12 17-48	Washer 25/32 x 1-5/8 x 16 Ga.
49	872 11 06-14	Bolt	206	532 44 85-96	Bracket Mount Latch Cruise
50	532 19 43-27	Pulley Idler Flat	207	587 03 14-01	Latch Control Cruise
51	873 90 06-00	Lock Nut 3/8-16	208	532 19 78-69	Gear Sector Control Cruise
52	532 19 43-26	Idler V-Groove	209	532 19 95-92	Rod Control Cruise
56	532 13 09-69	V-Belt, Drive	210	532 19 78-60	Rocker Asm Cruise
64	532 19 78-65	Shaft Asm. Pedal Brake Control	211	532 12 01-83	Bearing Nylon
69	532 42 33-03	Hairpin	213	532 40 31-19	Handle Parking Brake
70	532 43 96-61	Console Asm.	214	532 42 12-63	Pedal Forward
73	874 49 05-40	Bolt 5/16-18 x 1/2 Gr 5	215	586 60 65-02	Pedal Reverse
74	532 14 24-32	Screw Hx Wsh Hi-Lo 1/4 x 1/2 unc	220	532 19 89-08	Reflector RH
92	874 76 05-20	Bolt Fin Hex 5/16-18 unc x 1.25	221	532 40 31-87	Retainer Spring Clip Handle
99	582 40 45-01	Rod Bypass	222	879 21 20-10	Washer 21/32 x 1-1/4 10 Ga.
116	873 90 05-00	Nut Lock Hex Flange 5/16-18	225	532 40 33-19	Keeper Belt Trans.
125	817 00 05-12	Screw 5/16-18 x 3/4	227	817 49 05-12	Screw Thdrol 5/16-18 x 3/4
153	532 12 47-88	Retainer Spring	230	532 18 89-67	Washer Hardened
159	876 02 04-12	Pin Cotter 1/8 x 3/4	231	532 40 72-87	Idler Groove
160	532 16 94-84	Retainer Clip	325	586 43 12-02	Bracket
161	532 10 57-09	Spring, Return, Clutch	326	586 00 11-02	Bracket
163	532 44 82-75	Rod Pedal Control	336	587 25 96-01	Bolt
166	532 42 91-64	Nut Push .625			
167	532 40 52-57	Latch Brake Parking			
170	532 41 34-30	Keeper Belt Centerspan			
183	532 13 70-57	Spacer Axle			
184	587 65 37-01	Handle Parking Brake			

NOTE: All component dimensions given in U.S. inches
1 inch = 25.4 mm

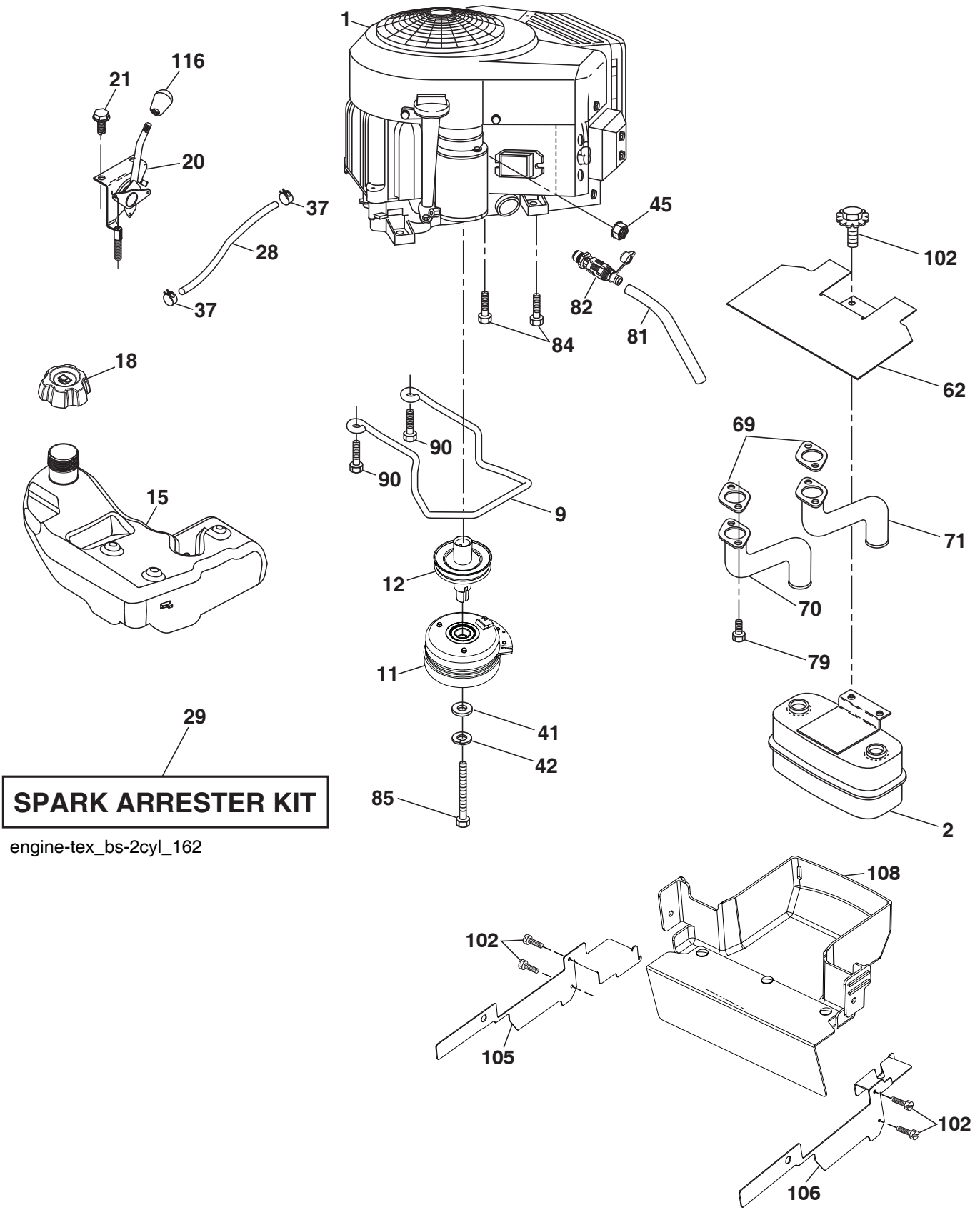

**TRACTOR - - MODEL NO. TS 343 (96041042300), PRODUCT NO. 960 41 04-23
ENGINE 24**

KEY NO.	PART NO.	DESCRIPTION
1	-----	Briggs&Stratton 44U677-0018-B1 (595898501) (Order parts from engine manufacturer.)
2	589 81 87-01	Muffler
9	501 83 26-02	Keeper Belt Engine
11	587 25 50-01	Clutch
12	586 89 96-01	Pulley Engine
15	532 19 34-99	Tank Fuel 4.0
18	584 24 87-02	Cap Fuel
20	532 42 43-41	Control Throttle/Choke
21	532 41 63-58	Screw #10 x 0.750
28	532 14 21-58	Fuel Line
29	532 13 71-80	Spark Arrester Kit
37	532 12 34-87	Clamp Hose
41	532 12 61-97	Washer 1-1/2 OD x 15/32 ID x .250
42	539 99 02-47	Washer Lock 7/16
45	873 51 04-00	Nut Keps 1/4-20 unc
62	532 43 40-17	Shield Heat Muffler
69	532 16 53-91	Gasket
70	581 88 11-01	Tube Exhaust LH
71	581 88 10-01	Tube Exhaust RH
79	532 18 39-06	Screw
81	532 14 84-56	Tube Drain Oil Easy
82	532 42 82-87	Valve Oil Drain
84	817 06 06-20	Screw
85	501 60 67-01	Bolt Hex 7/16-20 x 5
90	817 00 06-16	Screw 3/8-16 x 1
102	817 00 05-12	Screw 5/16-18 x 3/4
108	592 72 71-01	Cover Asm. Engine
105	591 20 49-02	Shield Chassis LH
106	591 20 50-02	Shield Chassis RH
116	539 13 26-24	Knob Shift

NOTE: All component dimensions given in U.S. inches
1 inch = 25.4 mm

Engine Power Rating Information

The gross power rating for individual gas engine models is labeled in accordance with SAE (Society of Automotive Engineers) code J1940 (Small Engine Power & Torque Rating Procedure), and rating performance has been obtained and corrected in accordance with SAE J1995 (Revision 2002-05). Torque values are derived at 3060 RPM; horsepower values are derived at 3600 RPM. Actual gross engine power will be lower and is affected by, among other things, ambient operating conditions and engine-to-engine variability. Given both the wide array of products on which engines are placed and the variety of environmental issues applicable to operating the equipment, the gas engine will not develop the rated gross power when used in a given piece of power equipment (actual "on-site" or net power). This difference is due to a variety of factors including, but not limited to, accessories (air cleaner, exhaust, charging, cooling, carburetor, fuel pump, etc.), application limitations, ambient operating conditions (temperature, humidity, altitude), and engine-to-engine variability. Due to manufacturing and capacity limitations, Briggs & Stratton may substitute an engine of higher rated power for this Series engine.

TRACTOR - - MODEL NO. TS 343 (96041042300), PRODUCT NO. 960 41 04-23
STEERING ASSEMBLY 41

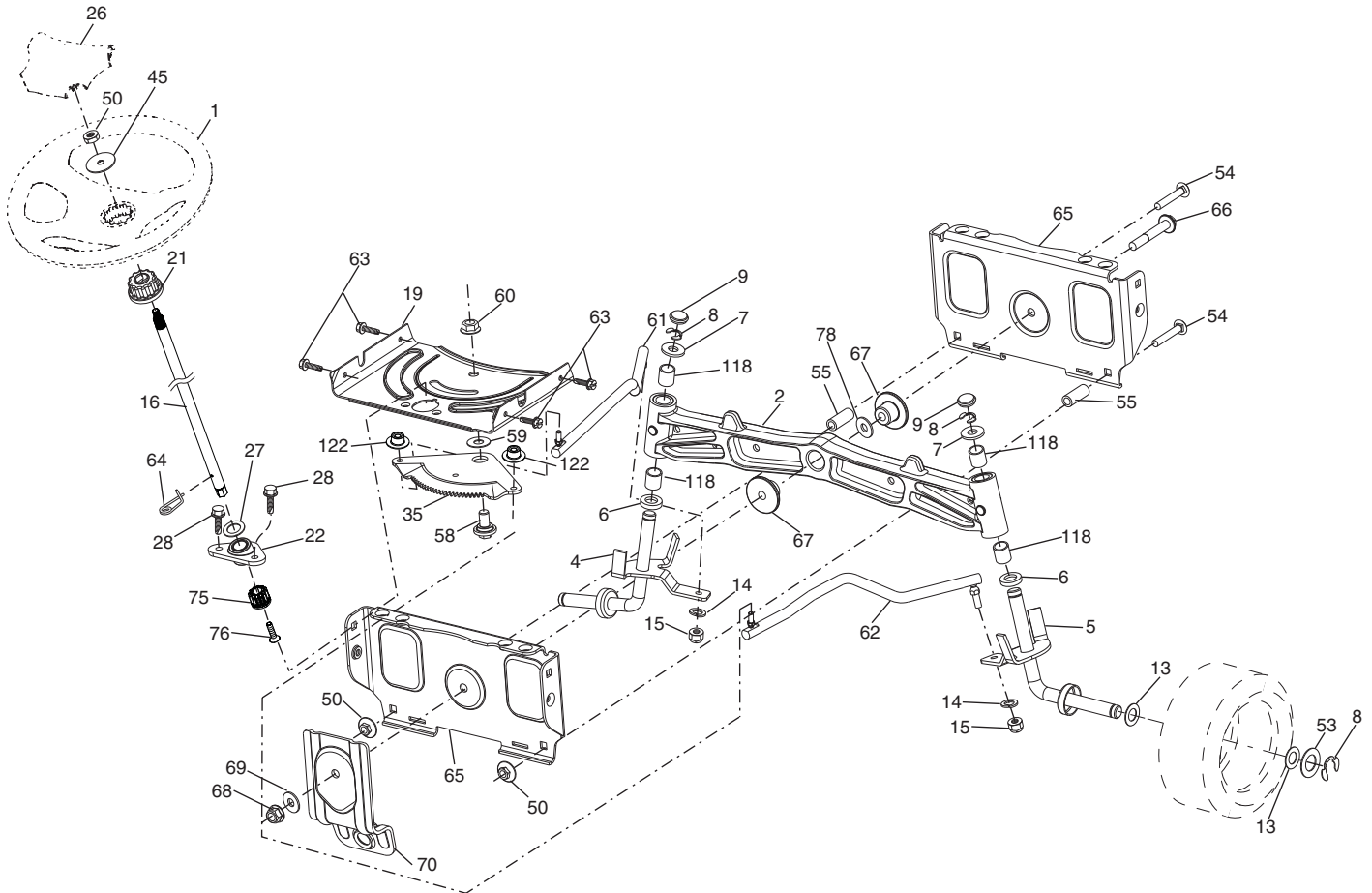

Steering-tex_LEGND2_56

TRACTOR - - MODEL NO. TS 343 (96041042300), PRODUCT NO. 960 41 04-23
STEERING ASSEMBLY 41

KEY NO.	PART NO.	DESCRIPTION
1	532 43 97-40	Wheel, Steering
2	532 41 35-91	Axle Asm.
4	586 72 40-01	Spindle Asm., LH
5	586 72 41-01	Spindle Asm., RH
6	532 12 49-31	Bearing, Race Thrust Harden
7	532 12 17-48	Washer 25/32 x 1-5/8 x 16 Ga.
8	812 00 00-29	Ring, Clip #T5304-75
9	532 12 12-32	Cap, Spindle
13	532 12 17-49	Washer 25/32 x 1-1/4 x 16 Ga.
14	539 99 01-18	Washer, Lock Hvy Hlcl Spr 3/8
15	873 54 06-00	Nut, Crown Lock 3/8-24 unf
16	587 01 60-02	Steering Shaft
19	532 19 47-29	Plate Steering
21	586 84 02-01	Adapter Wheel Steering
22	585 02 99-01	Bearing
26	532 43 97-43	Insert, Wheel Steering
27	819 21 16-16	Washer
28	817 00 06-12	Screw 3/8-16 x 3/4
35	532 19 47-32	Gear, Sector Plate
45	587 01 64-01	Washer 3/8 ID 2-3/8 OD 12 Ga. PLTD
50	873 90 06-00	Nut Lock Flg 3/8-16 unc
53	532 18 89-67	Washer Hardened .793 x 1.637 x .060
54	874 76 06-36	Bolt Hex 3/8-16 unc x 2-1/4
55	532 41 47-36	Spacer Brace Axle
58	532 19 47-47	Bolt Shoulder Sector Pivot CFM
59	532 19 47-48	Washer Thrust Sector Steering
60	873 97 10-00	Nut Flange Lock 5/8-11
61	588 79 44-02	Draglink, LH
62	588 79 45-02	Draglink, RH
63	817 00 05-12	Screw 5/16-18 x 3/4
64	532 19 98-49	Retainer Clip Spring Steering
65	532 19 47-34	Brace Axle Front
66	871 02 07-48	Bolt Hex Fghd 7/16-14 x 3 Serr
67	532 19 47-37	Bushing PM Front Axle
68	873 90 07-00	Nut Lock Flange 7/16-14 Gr. 5
69	532 19 91-62	Washer 1.5 x .505 x .118
70	585 33 88-01	Bracket Deck Susp. Front
75	580 68 37-01	Pinion
76	580 68 36-01	Screw Head Sock
78	532 05 70-79	Washer Thrust
118	532 40 60-13	Bushing Axle
122	532 44 49-62	Cap Gear Sector Tex

NOTE: All component dimensions given in U.S. inches
1 inch = 25.4 mm

TRACTOR - - MODEL NO. TS 343 (96041042300), PRODUCT NO. 960 41 04-23
MOWER DECK 44

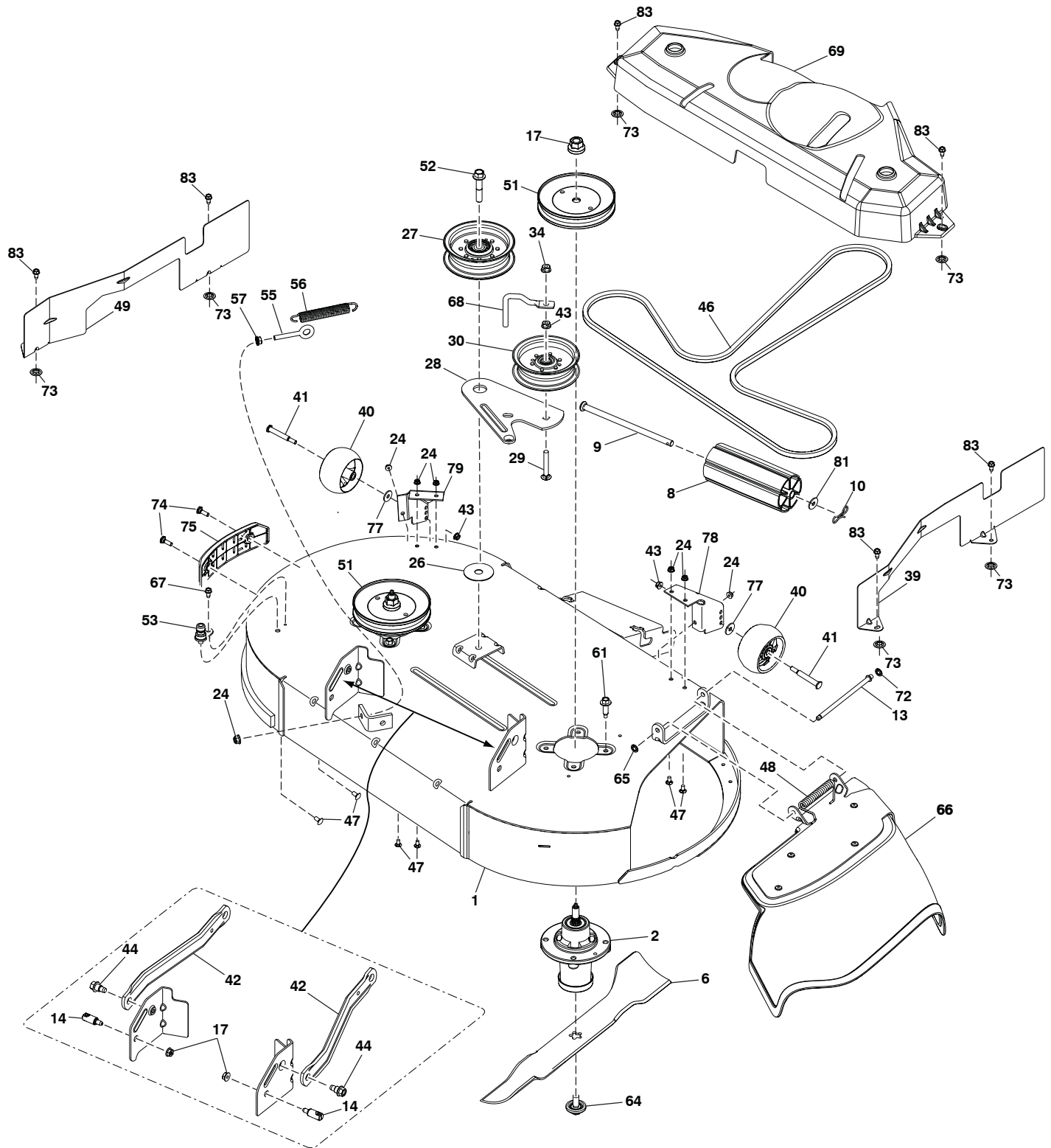

Mower Deck-tex_42F Flat_elec_9

TRACTOR - - MODEL NO. TS 343 (96041042300), PRODUCT NO. 960 41 04-23
MOWER DECK 44

KEY NO.	PART NO.	DESCRIPTION
1	501 58 8801	Kit SVC Weldment
2	539 13 18-98	Housing, Assembly
6	592 76 97-08	Blade 42 Clearcut Euro Rev
8	532 17 60-66	Nose Roller
9	532 17 91-27	Rod Roller Nose
10	532 19 42-08	Pin Locking Cotter
13	532 13 14-91	Deflector Hinge Pin
14	532 19 51-61	Stud, Fastening
17	873 90 05-00	Locknut, Hex Flanged
24	539 11 28-99	Nut 5/16-18 Hex Flange
26	532 17 85-15	Washer, Flat Hardened Steel
27	532 19 61-04	Pulley, Idler 4.50
28	586 87 40-02	Arm 42 FCS Clutching
29	539 12 81-01	Bolt RHD 3/8-16 x 2-1/2
30	532 19 61-06	Pulley 4.50 Idler
34	873 68 06-00	Nut Crownlock 3/8-16 unc
39	588 90 75-02	Shield 42 Clearcut RH
40	589 52 73-01	Gauge Wheel
41	532 19 34-06	Bolt Shoulder
42	532 19 51-85	Arm, Suspension RR
43	873 90 06-00	Nut Lock Flg 3/8-15 unc
44	532 19 65-39	Screw, Shoulder
46	501 13 89-01	Belt 42 Clearcut Euro
47	539 99 03-16	RHSNB 5/16 Hx. Whs. Hd. LCKSERR
48	587 35 47-01	Spring, 42 FCS Deflector
49	588 90 74-02	Shield 42 Clearcut LH Deck
51	532 19 74-73	Pulley, Mandrel
52	588 43 83-01	Screw 7/16-14 x 2.125 Hex
53	532 41 55-98	Plate Washout Port
55	539 11 55-74	Bolt Eye 5/16 x 3.50
56	587 35 84-01	Spring, 42 FCS Tractor DK DRV
57	539 99 05-85	Nut 5/16-18 unbc-28 Fln
61	584 95 39-01	Bolt Hex 5/16-18 x 1.310
64	532 19 30-03	Bolt/Washer 7/16-20
65	532 11 04-52	Hinge Pin Push Nut
66	587 30 57-01	Deflector Assembly
67	532 13 77-29	Screw 1/4-20 x 5/8
68	532 19 84-68	Keep Belt
69	588 90 76-01	42 Clearcut Euro Mandrel Cover
72	532 10 53-04	Cap Sleeve
73	532 42 30-62	Palnut 1/4
74	532 17 01-65	Bolt 5/16-18
75	582 68 32-03	Bumper
77	819 12 14-14	Washer 5/16 Flat
78	501 80 83-02	Gauge Wheel Breacket RH
79	590 43 90-02	Gauge Wheel Breacket LH
81	582 36 05-01	Bushing Nose Roller
83	817 49 04-10	Screw 1/4-20 x 5/8 Hx. Self Tap ZD
--	597 13 45-01	Deck SVC 42F
--	589 65 96-01	Kit 42FCS Mulch W/O Blades

NOTE: All component dimensions given in U.S. inches
1 inch = 25.4 mm

TRACTOR - - MODEL NO. TS 343 (96041042300), PRODUCT NO. 960 41 04-23
MOWER LIFT 45

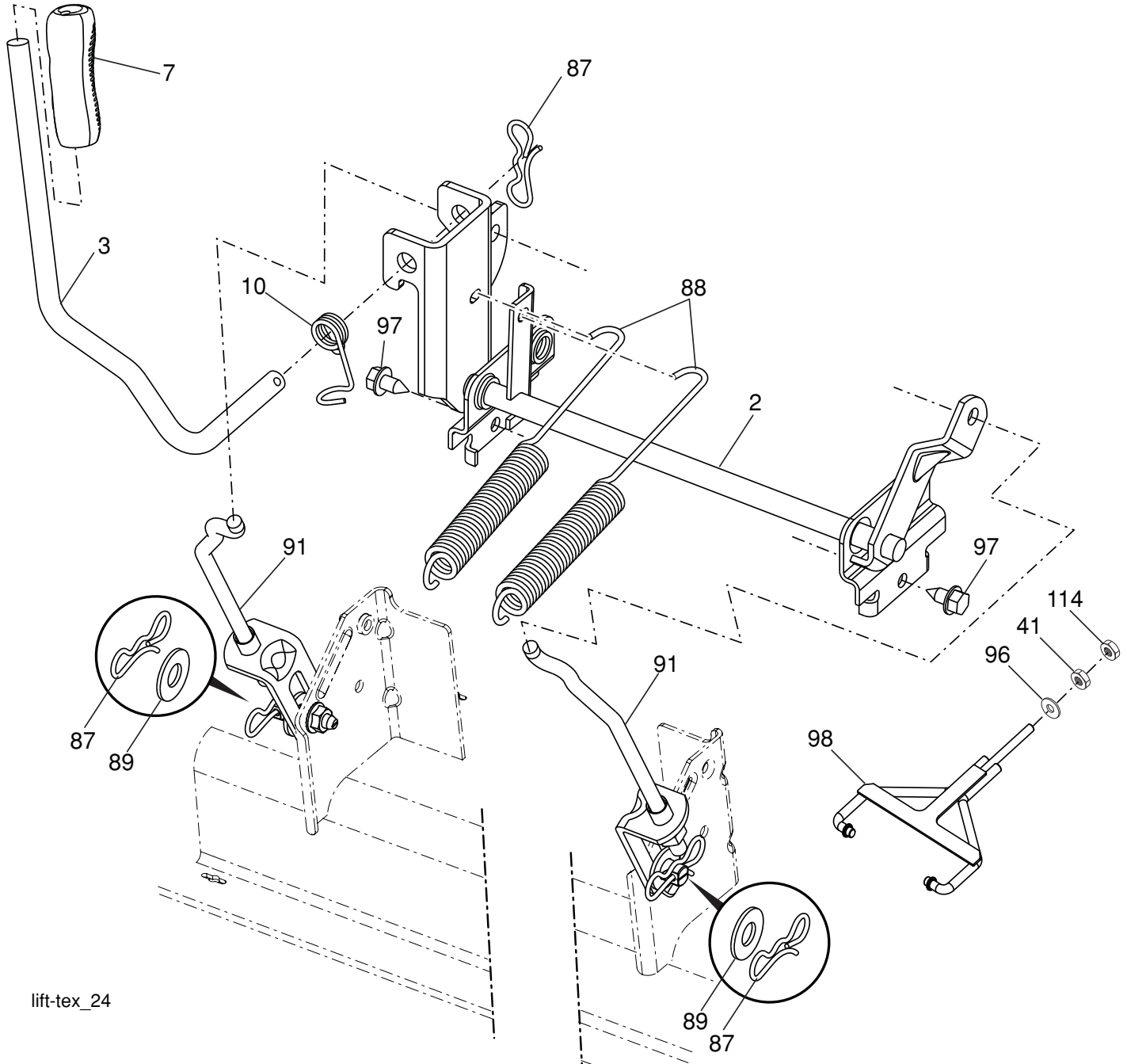

lift-tex_24

KEY PART NO.	PART NO.	DESCRIPTION
2	532 42 20-27	Shaft Asm., Lift
3	532 19 52-30	Lever Asm., Lift RH
7	580 96 23-01	Grip, Lever
10	532 19 63-14	Spring Torsion
41	532 17 59-94	Nut, Lift Link
87	532 19 42-09	Pin Cotter 7/16 Bow Tie Lock
88	532 41 07-10	Spring Lift Assist
89	819 19 19-12	Washer Clear Zinc

KEY PART NO.	PART NO.	DESCRIPTION
91	532 40 34-07	Link Lift Susp Mower Rear
96	532 19 52-63	Bushing, Spherical
97	817 00 06-12	Screw 3/8-16 x .75
98	574 82 25-01	Link Lift Susp. Front Mower
114	873 36 07-00	Nut Jam 7/16-20

NOTE: All component dimensions given in U.S. inches
 1 inch = 25.4 mm

**TRACTOR - - MODEL NO. TS 343 (96041042300), PRODUCT NO. 960 41 04-23
SEAT ASSEMBLY 42**

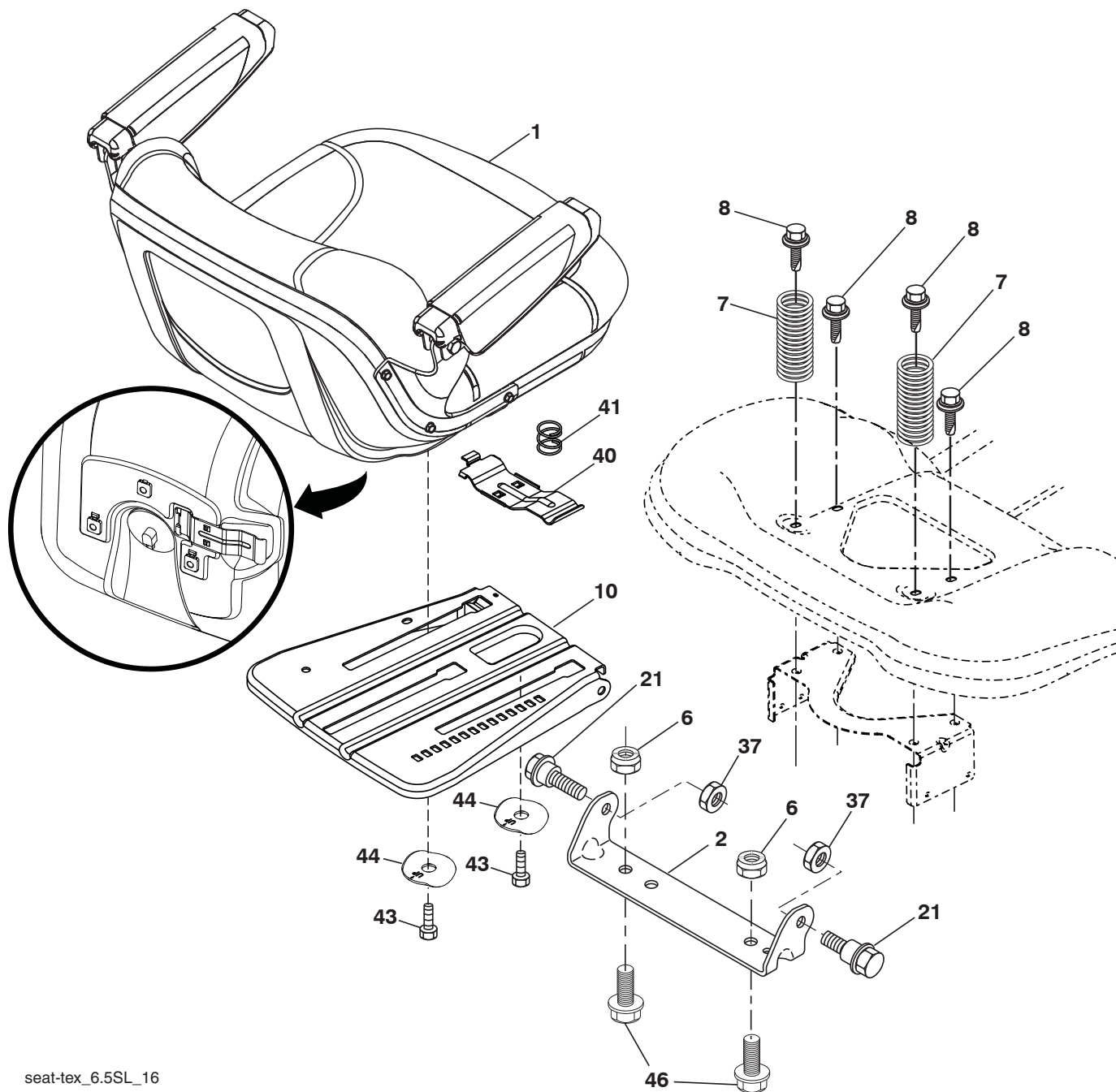

seat-tex_6.5SL_16

KEY NO.	PART NO.	DESCRIPTION
1	588 55 67-01	Seat
2	532 18 01-66	Bracket Pivot Fender
6	873 80 06-00	Nut, Lock W/Ins. 3/8-16 unc
7	589 48 35-01	Spring, Seat Cprsn
8	532 17 18-77	Bolt 5/16-18 unc x 3/4 w/Sems
10	596 65 74-02	Pan, Seat
21	587 90 78-01	Bolt, Shoulder 5/16-18 x 5/8
37	873 80 05-00	Nut, Lock 5/16-18 unc

KEY NO.	PART NO.	DESCRIPTION
40	532 19 76-61	Handle Slide Seat
41	532 19 82-00	Spring Latch Seat
43	874 76 06-12	Bolt Fin Hex 3/8-16 unc x 3/4
44	501 05 18-01	Washer Winged
46	588 09 04-01	Bolt 3/8-16 x1, 1.25 OD Wshr.

NOTE: All component dimensions given in U.S. inches
1 inch = 25.4 mm

