

ILLUSTRATED PARTS LIST

MFG. ID NO. 96051018200

CUSTOMER CATALOG NO. TC 239T

PRODUCT NO. 960 51 01-82

47

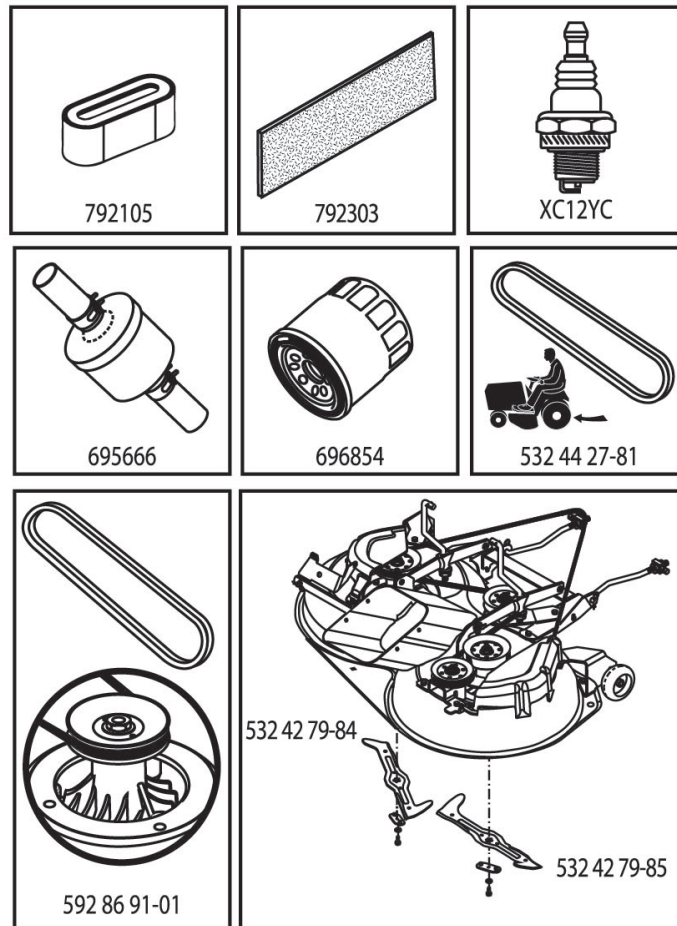

596396001

**TRACTOR - - MODEL NO. TC 239T (96051018200), PRODUCT NO. 960 51 01-82
DECALS 27**

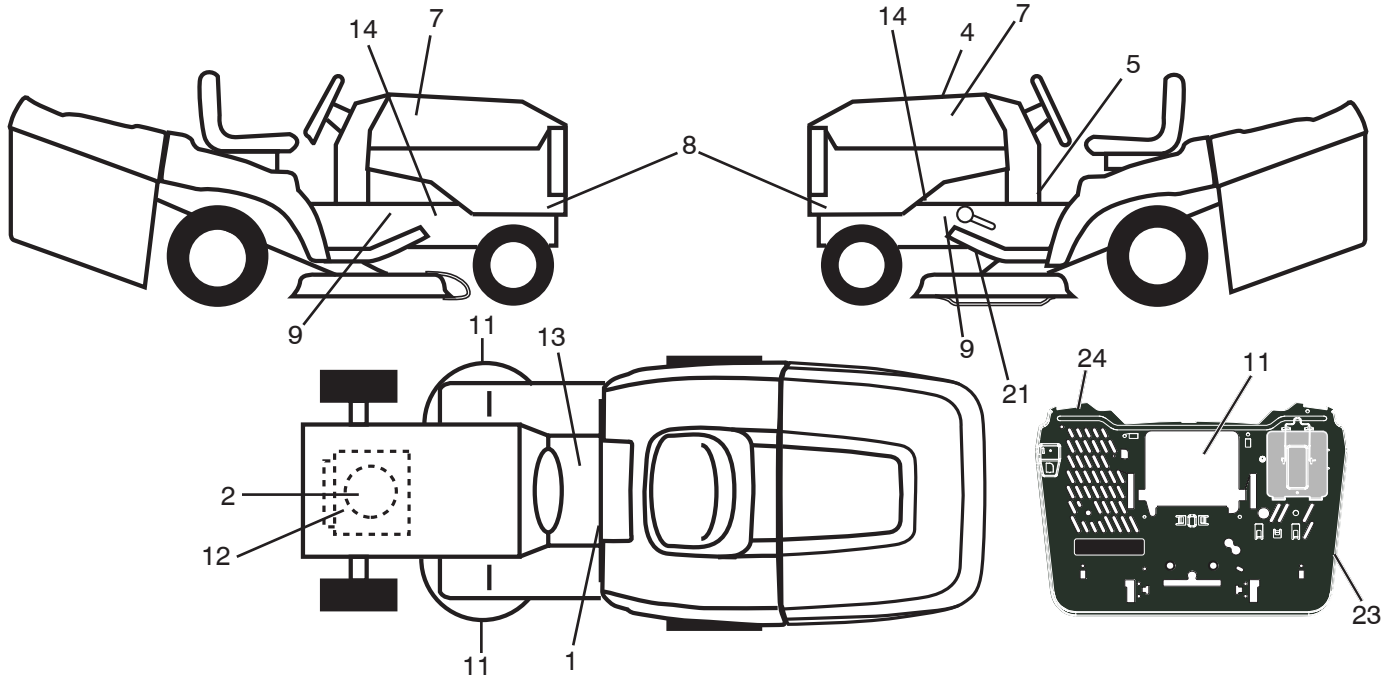

KEY NO.	PART NO.	DESCRIPTION
1	581 57 83-01	Decal, Warning
2	581 57 97-01	Decal, Warning Eng. Sym.
4	596 39 60-01	Decal, Replacement
5	581 57 84-01	Decal, Lower Dash
7	581 62 73-01	Decal, Hood
8	589 44 14-01	Decal, Side Panel
9	581 57 98-01	Decal, Warning
11	581 57 91-01	Decal, Mower Cut Finger Symbol
12	587 46 91-01	Decal, Engine B&S
13	586 80 03-01	Decal, Tractor Saddle
14	581 57 96-01	Decal, Chassis Hot Muffler

KEY NO.	PART NO.	DESCRIPTION
21	592 98 02-01	Decal, Belt Schematic
23	532 44 46-19	Decal, Bypass
24	532 44 54-93	Decal, Warning Combined
--	532 44 14-09	Pad Footrest LH
--	532 44 14-10	Pad Footrest RH
--	114 06 14-20	Manual Operator's (Euro)
--	114 06 15-10	Manual Operator's (Scan)
--	114 06 16-50	Manual Operator's (EBloc)
--	114 06 17-40	Manual Operator's (Baltic)

WHEELS AND TIRES

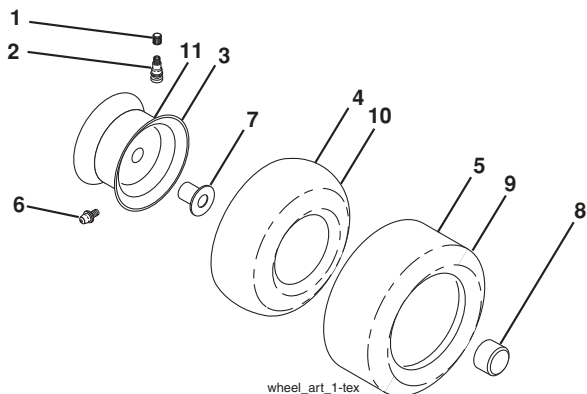

wheel_art_1-tex

KEY NO.	PART NO.	DESCRIPTION
1	532 05 91-92	Cap Valve Tire
2	532 06 51-39	Stem Valve
3	532 13 83-36	Rim Front
4	532 05 99-04	Tube Front (Service Item Only)
5	532 10 62-22	Tire Front 15 x 6-6
6	532 12 49-57	Fitting Grease (Front Wheel Only)
7	532 12 49-59	Bearing Flange (Front Wheel Only)
8	532 17 50-39	Cap Axle Blk 1 50 x 1 00
9	532 42 05-31	Tire R 18 x 9.5-8
10	532 00 71-52	Tube Rear (Service Item Only)
11	532 13 83-37	Rim Asm 8" Rear
--	532 14 43-34	Sealant, Tire (10 oz. Tube)

NOTE: All component dimensions given in U.S. inches
1 inch = 25.4 mm

TRACTOR - - MODEL NO. TC 239T (96051018200), PRODUCT NO. 960 51 01-82

SCHEMATIC **38**

SCH19

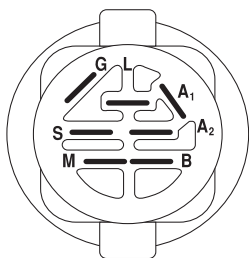
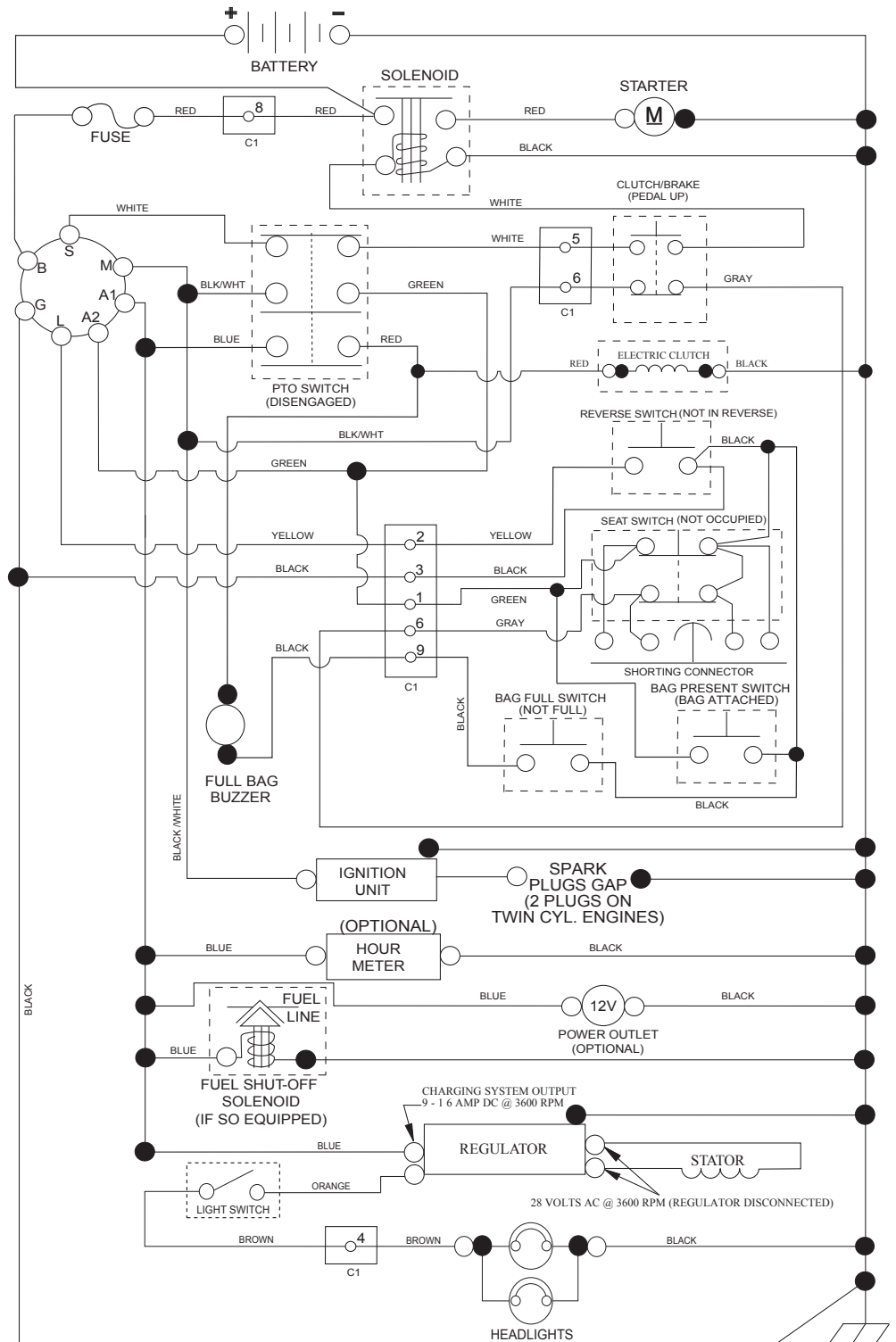

IGNITION SWITCH

POSITION	CIRCUIT "MAKE"
OFF	M+G+A1
RUN/OVERRIDE	B+A1
RUN	B+A1 L+A2
START	B + S + A1

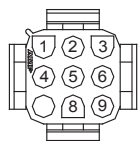

CHASSIS HARNESS CONNECTOR (C1) (MATING SIDE)

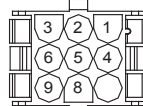

DASH HARNESS CONNECTOR (C1) (MATING SIDE)

WIRING INSULATED CLIPS
NOTE: IF WIRING INSULATED CLIPS WERE REMOVED FOR SERVICING OF UNIT, THEY SHOULD BE RE-INSTALLED TO PROPERLY SECURE YOUR WIRING.

● NON-REMOVABLE CONNECTIONS

○ REMOVABLE CONNECTIONS

TRACTOR - - MODEL NO. TC 239T (96051018200), PRODUCT NO. 960 51 01-82
ELECTRICAL 32

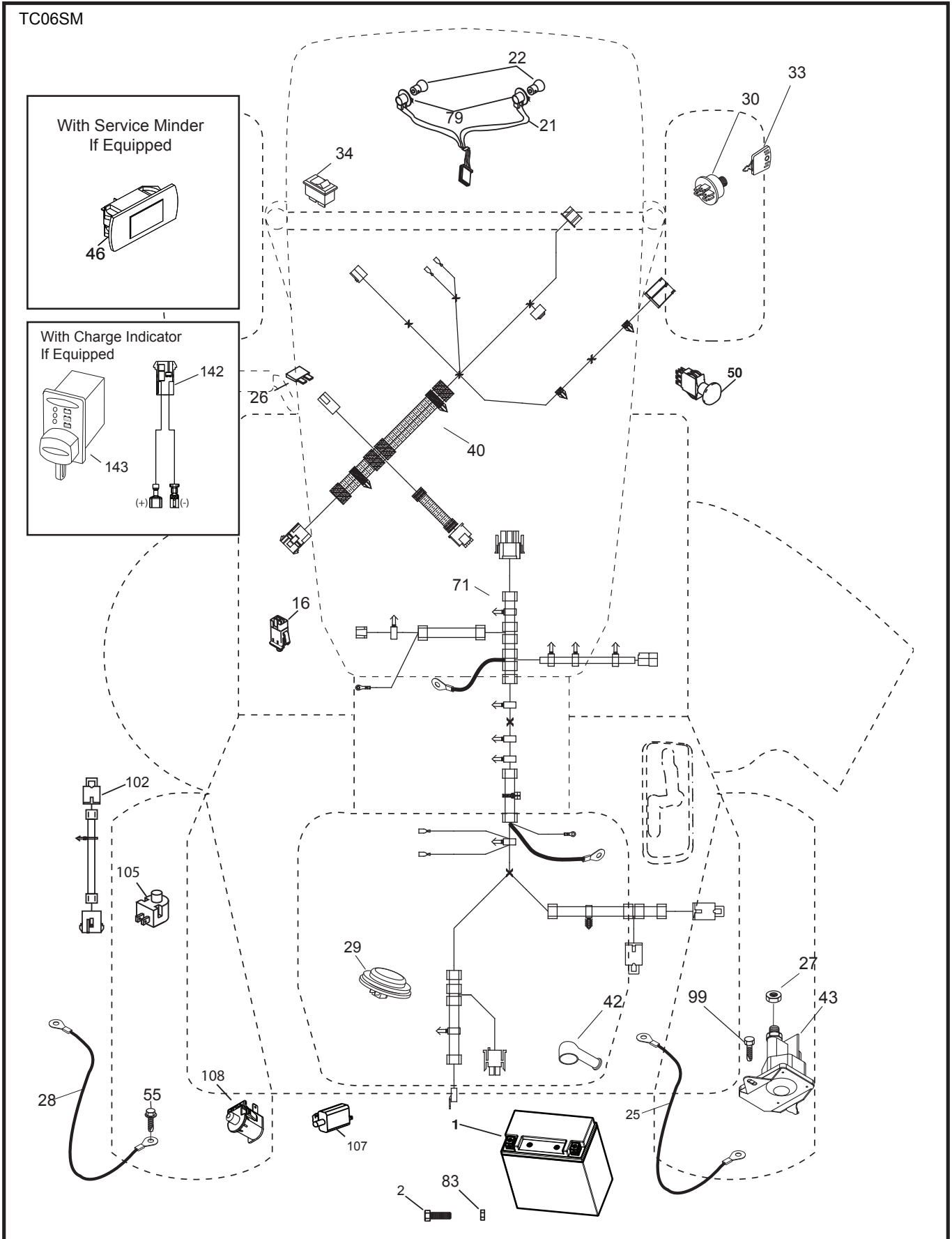

**TRACTOR - - MODEL NO. TC 239T (96051018200), PRODUCT NO. 960 51 01-82
ELECTRICAL 32**

KEY NO.	PART NO.	DESCRIPTION
1	532 43 71-57	Battery
2	532 44 09-23	Screw Hex Hd Cap M6 x 1.12mm
16	532 17 61-38	Switch Interlock Push-In
21	532 40 02-52	Harness Light
22	532 00 41-52	Bulb Light
25	589 32 37-01	Cable Batt 8 Ga. Red 9
26	532 17 51-58	Fuse
27	873 51 04-00	Nut Keps Hex 1/4-20 unc
28	589 32 36-01	Cable, Ground
29	532 40 15-45	Switch, Seat
30	532 19 33-50	Switch, Ign
33	532 41 19-35	Key/Chain Blister Pack
34	532 11 07-12	Switch Light Blk Red
40	587 26 89-01	Harness Ign. Dash
42	532 13 15-63	Cover Terminal Red
43	582 04 28-01	Solenoid
46	586 16 18-01	Gauge Serviceminder Hrmtr
50	582 10 76-01	Switch PTO
55	817 06 05-12	Screw Thdrol 5/16-18 x 3/4 TYTT
71	587 26 87-01	Harness Ignition Chassis
79	532 17 52-42	Socket, Asm. Bulb
83	532 43 67-74	Nut Square M6 x 1.8.5 x 11mm
99	817 00 05-12	Screw Thrdrol 5/16-18 x 3/4
102	532 44 12-62	Harness Jumper
105	532 40 75-68	Switch Reverse
107	532 18 03-79	Switch Full Bagger
108	589 50 03-01	Switch Snapmount

NOTE: All component dimensions given in U.S. inches
1 inch = 25.4 mm

TRACTOR - - MODEL NO. TC 239T (96051018200), PRODUCT NO. 960 51 01-82
CHASSIS AND ENCLOSURES **39**

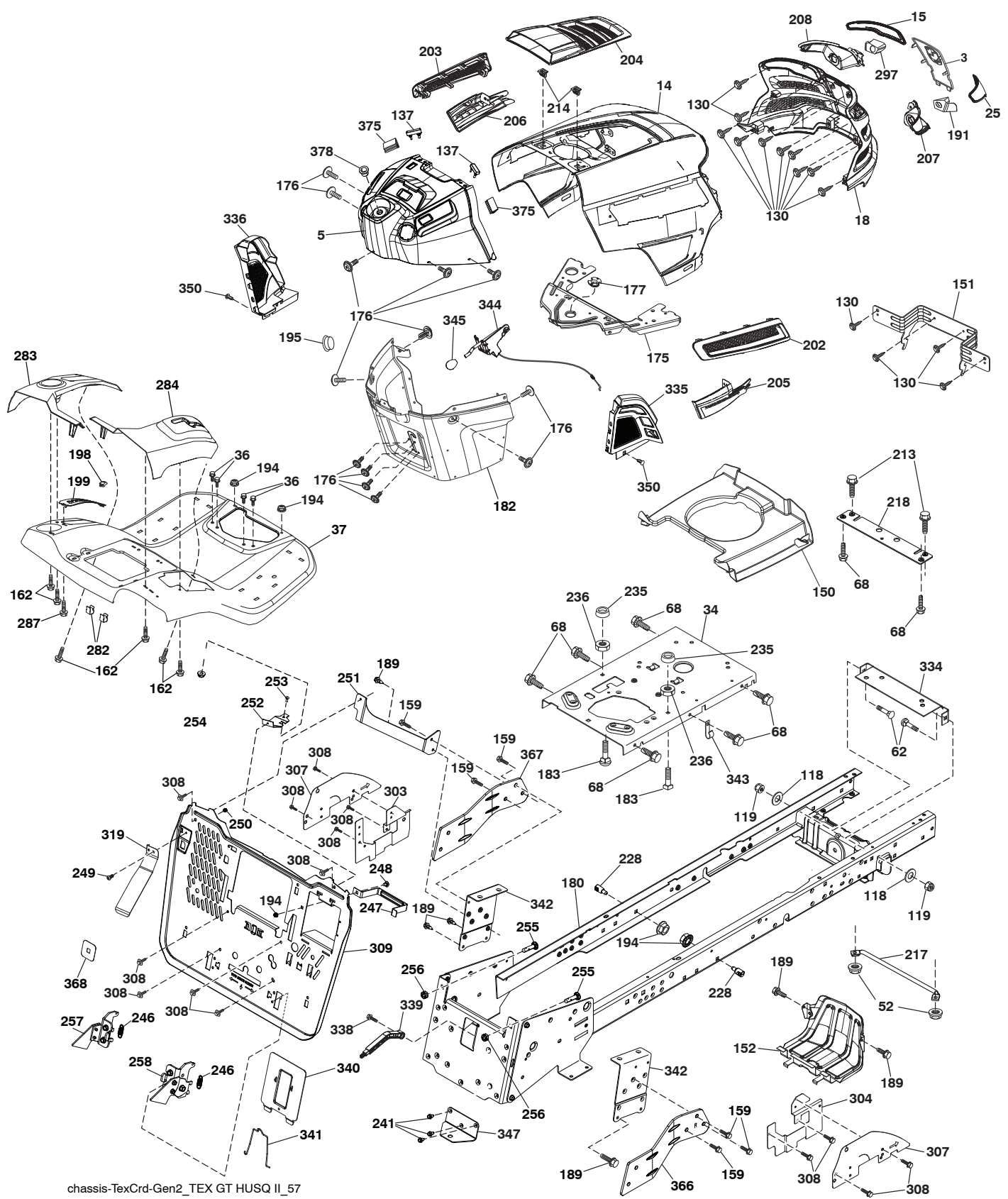

chassis-TeXCrd-Gen2_TEX GT HUSQ II_57

**TRACTOR - - MODEL NO. TC 239T (96051018200), PRODUCT NO. 960 51 01-82
CHASSIS AND ENCLOSURES **39****

KEY NO.	PART NO.	DESCRIPTION	KEY NO.	PART NO.	DESCRIPTION
3	532 44 44-81	Applique	256	532 19 07-33	Nut Jam 3/8-16
5	590 07 00-21	Dash	257	589 74 66-02	Bagger Latch Assembly LH
14	532 44 11-77	Hood	258	589 74 67-02	Bagger Latch Assembly RH
15	532 43 97-33	Lens LH	282	532 41 41-10	Clip Retainer
18	587 52 34-01	Grille	283	532 44 72-12	Console Deck Lift LH
25	532 44 33-85	Lens RH	284	532 44 72-20	Console Shft RH
34	580 91 09-01	Plate Engine	287	817 60 04-06	Screw 1/4-20 x 3/8
36	817 06 05-12	Screw 5/16-18 x 3/4	297	532 43 74-56	Insert Reflective LH
37	532 44 13-69	Fender	303	589 00 76-02	Shield Chassis French LH
52	873 68 05-00	Nut Lock 5/16-18	304	589 00 68-02	Shield Chassis French RH
62	872 11 06-08	Bolt RdHd Sqnk 3/8-16 x 1 Gr. 5	307	587 49 45-01	Shield Upper French
68	539 99 08-58	Screw Thdrol 5/16-18 x 1/2	308	532 17 18-77	Bolt 5/16-18 unc x 3/4 w/Sems
118	819 13 13-16	Washer 13/32 x 13/16 x 16 Ga.	309	582 55 25-02	Backplate
119	873 68 06-00	Nut Crownlock 3/8-16 unc	319	581 31 39-07	Lever Bag
130	532 41 63-58	Screw #10 x 0.750	334	532 44 25-37	Bracket Engine
137	532 40 75-90	Bumper Dash	335	532 44 82-04	Cover RH Lower Close Out
150	532 43 97-74	Air Duct	336	532 44 53-09	Cover LH Lower Close Out
151	532 43 66-70	Bracket Pivot	338	532 43 66-40	Bolt Shoulder
152	532 43 98-70	Shield Browning	339	532 43 66-41	Lever Bagger Full
159	817 00 06-12	Screw Hexwsh Thrd 3/8-16 x 3/4	340	582 55 27-02	Battery Door
162	532 14 24-32	Screw	341	582 06 08-01	Battery Door Latch
175	590 60 77-02	Crossmember	342	582 82 68-02	Supprt Fender
176	532 40 07-76	Screw 10-24 x 5/8	343	532 44 07-49	Clip
177	532 19 52-28	Bushing Steering	344	532 43 89-70	Control EZ Mulch
180	593 89 88-01	Chassis	345	532 44 06-39	Knob
182	586 73 87-02	Dash Lower	347	532 44 28-87	Hitch Tow
183	874 52 05-20	Bolt 5/16-18 x 1-1/4	350	532 44 51-43	Clip X-Mas Tree
189	817 00 05-12	Screw 5/16-18 x 3/4	366	581 31 46-02	Bracket RH Front Bagger
191	532 43 74-55	Insert Reflective RH	367	581 31 45-02	Bracket LH Front Bagger
194	873 90 05-00	Nut Lock Hex Flange 5/16-18	368	581 42 48-01	Full Lever Shroud
195	532 40 41-37	Plug Hole Dash Lower	375	586 90 82-01	Dash Clip-On Bumper
198	532 44 15-52	Indicator Deck Lift	378	590 84 98-01	Bushing Flange
199	532 41 87-39	Plate Deck Lift	--	589 45 39-01	Kit ID Box -This kit includes Battery Hardware (532 44 09-23 Screw Hex Head Cap M6 x 1.2mm), 532 43 67-74 Nut Square M6 x 1.8.5 x 11mm; refer to pages 4 & 5 in this IPL, Chassis Parts/Hardware (532 44 28-87 Tow Hitch), (532 43 66-41 Bagger Full Lever); refer to pages 6 & 7 in this IPL, Bagger Parts/Hardware (582 36 48-01 Bagger Latch), Bagger Presence Lever/Hardware (581 31 39-06 Bagger Presence lever), (586 93 60-01 Screw Buttonhead 10-24 x 1/2), (539 97 69-77 Nut Hex 10-24), (817 00 06-12 Screw Hexwsh Trdr 3/8-16 x 3/4), (872 11 06-08 Bolt Rdhd Sqnk 3/8-16 x 1 Gr. 5), (873 80 06-00 Nut Lock 3/8-16 unc); refer to pages 18 & 19 in this IPL.
202	532 43 97-28	Vent Side Hood RH			
203	532 43 97-27	Vent Side Hood LH			
204	532 43 57-14	Vent Top Hood			
205	532 43 97-30	Skirt Hood Side RH			
206	532 43 97-29	Skirt Hood Side LH			
207	587 46 48-01	Bezel RH			
208	587 46 45-01	Bezel LH			
213	539 97 69-34	Bolt 5/16-18 x 3/4 HSC			
214	532 19 91-45	Clip Retainer Tinner			
217	532 40 91-67	Rod Pivot			
218	532 19 63-95	X-Piece Hood Stop			
228	532 19 51-61	Stud Fastner			
235	532 40 61-29	Spacer Fender			
236	873 93 05-00	Nut Lock 5/16-18 unc			
241	817 06 05-16	Screw 5/16-18 x 1			
246	591 44 90-01	Bagger Latch Extension Spring			
247	582 55 26-02	Battery Strap			
248	872 11 05-04	Bolt Rdhd Sqnk 5/16-18 x 1/2 Gr. 5			
249	586 93 60-01	Screw Bnhd 10-24 x 1/2 Patched			
250	539 97 69-77	Nut Lock Hx w/ins 10-24 unc			
251	589 31 89-04	LH Backplate Support Bracket			
252	581 99 22-04	RH Backplate Support Bracket			
253	539 11 56-20	Bolt Carr. 1/4-20 x 3/4			
254	873 90 04-00	Nut Lock Hex Flange 1/4-20			
255	589 39 22-02	Bolt Cross Drilled 3/8-16 x 1.75			

NOTE: All component dimensions given in U.S. inches
1 inch = 25.4 mm

TRACTOR - - MODEL NO. TC 239T (96051018200), PRODUCT NO. 960 51 01-82
 DRIVE **40**

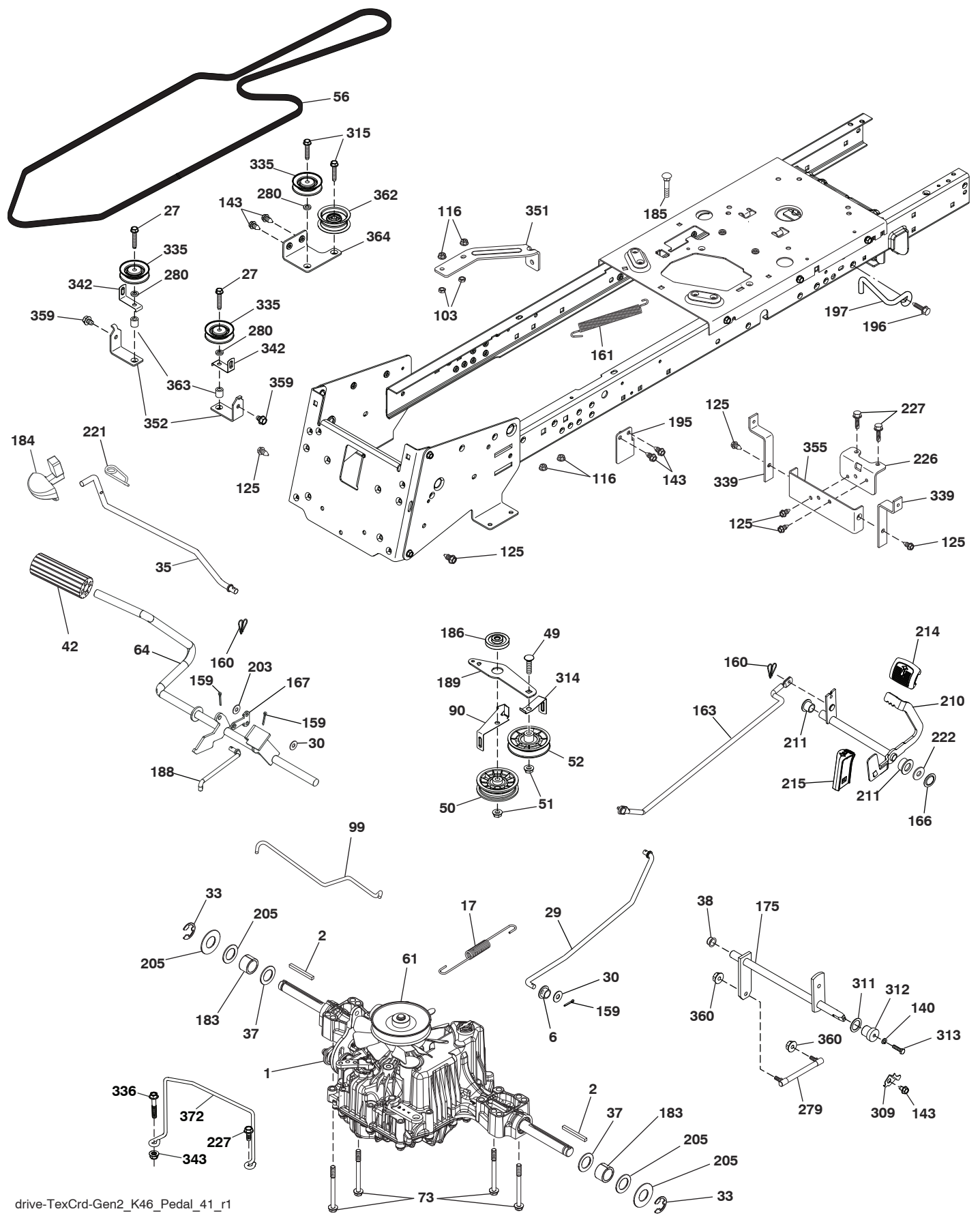

drive-TeXCrd-Gen2_K46_Pedal_41_r1

**TRACTOR - - MODEL NO. TC 239T (96051018200), PRODUCT NO. 960 51 01-82
DRIVE **40****

KEY NO.	PART NO.	DESCRIPTION	KEY NO.	PART NO.	DESCRIPTION
1	---	Transaxle, Tufftorq K46DF (446488) (Order parts from trans-axle manufacturer.)	189	532 43 36-11	Bellcrank Ground Drive
2	532 12 35-83	Key Square	195	580 45 69-01	Bracket Rod Brake CRD Tex
6	532 12 40-28	Bushing Snap	196	817 00 06-16	Screw 3/8-16 x 1 Smgml Tap/R Blk
17	532 43 62-27	Spring Brake K46	197	585 65 86-01	Link Clutch Anti-Rotation
27	817 49 05-28	Screw Hexwsh Thd 5/16-18 x 1-3/4	203	819 11 11-16	Washer 11/32 x 11/16 x 16 Ga.
29	532 44 27-95	Rod, Brake	205	532 12 17-48	Washer 25/32 x 1-5/8 x 16 Ga.
30	819 13 16-16	Washer	210	532 40 09-80	Rocker Asm. Pedal Control
33	812 00 00-01	Ring E	211	532 12 01-83	Bearing Nylon
35	583 86 45-01	Rod, Brake, Park	214	532 42 12-63	Pedal Forward
37	532 18 89-67	Washer Harden .793 x 1.063 x .060	215	586 60 65-02	Pedal Reverse
38	532 16 96-13	Nyliner Bushing	221	532 40 31-87	Retainer Spring Clip Handle
42	532 12 48-72	Cover, Foot Pedal	222	879 21 20-10	Washer 21/32 x 1-1/4 10 Ga.
49	872 11 06-14	Bolt Rdhd 3/8-16 unc x 3/4 Gr. 5	226	532 40 15-64	Bracket Strap Torque
50	532 19 43-27	Idler Flat	227	817 49 05-12	Screw
51	873 90 06-00	Lock Nut 3/8-16	279	532 44 42-83	Link Shift
52	532 19 43-26	Idler V-Groove	280	819 11 10-12	Washer 11/32 x 5/8 x 12 Ga.
56	591 06 53-01	V-Belt, Drive	309	532 16 55-81	Plate Fstnr Cross Shf
61	532 44 51-51	Pulley Transaxle K46	311	532 16 98-45	Washer Nylon
64	532 19 78-65	Shaft Asm. Pedal Brake Control	312	532 16 56-14	Hub Tapered
73	874 49 05-44	Bolt Flanged	313	874 78 04-16	Bolt Hex Fin 1/4-20 unc x 1 Gr. 5
90	532 44 36-05	Keeper Belt Clutching	314	532 44 47-13	Keeper Belt
99	532 44 39-47	Rod Spring Bypass	315	817 58 05-20	Screw Thdrol 5/16-18 x 4.25
103	873 35 05-00	Nut Hex Jam 5/16-18	335	532 19 95-34	Pulley V-Idler
116	873 90 05-00	Nut Lock Hex Flange 5/16-18	336	587 25 96-01	Bolt 5/16-18 x 1-3/4 Flanged hex
125	817 00 05-12	Screw 5/16-18 x 3/4	339	532 43 68-67	Strap Torque K46 CRD Tex
140	810 04 04-00	Washer Lock Hvy Helical 1/4	342	532 18 26-82	Keeper Belt 2.5" STL V-Idlr CRD
143	539 99 08-58	Screw 5/16-18 x 1/2	343	539 11 28-99	Nut 5/16-18 Hex Flanged Nyloc
159	876 02 04-12	Pin Cotter 1/8 x 3/4	351	532 43 69-98	Bracket 97 CRD Deck Sway
160	532 16 94-84	Retainer Clip	352	532 43 56-45	Bracket Idler CRD Tex
161	532 10 57-09	Spring, Return, Clutch	355	532 43 56-69	Strap Torque
163	532 44 27-93	Rod Control	359	817 49 06-10	Screw Thdrol 3/8-16 x 5/8
166	532 42 91-64	Nut Push	360	532 44 47-14	Nut 5/16-24 unf
167	532 40 52-57	Latch Brake Parking	362	532 43 68-12	Idler Flat
175	532 42 93-59	Shaft Asm Crossshift Rear CRD	363	532 44 27-80	Spacer .343 x .63 x .62
183	532 13 70-57	Spacer Axle	364	532 44 30-32	Bracket Idler CRD Tex
184	587 65 37-01	Handle Parking Brake	372	582 65 49-01	Keeper Belt Transaxle
185	872 11 06-22	Bolt 3/8-16 unc x 2-3/4 Gr. 5			
186	532 19 43-21	Spacer Retainer			
188	582 21 70-01	Link Clutch			

NOTE: All component dimensions given in U.S. inches
1 inch = 25.4 mm

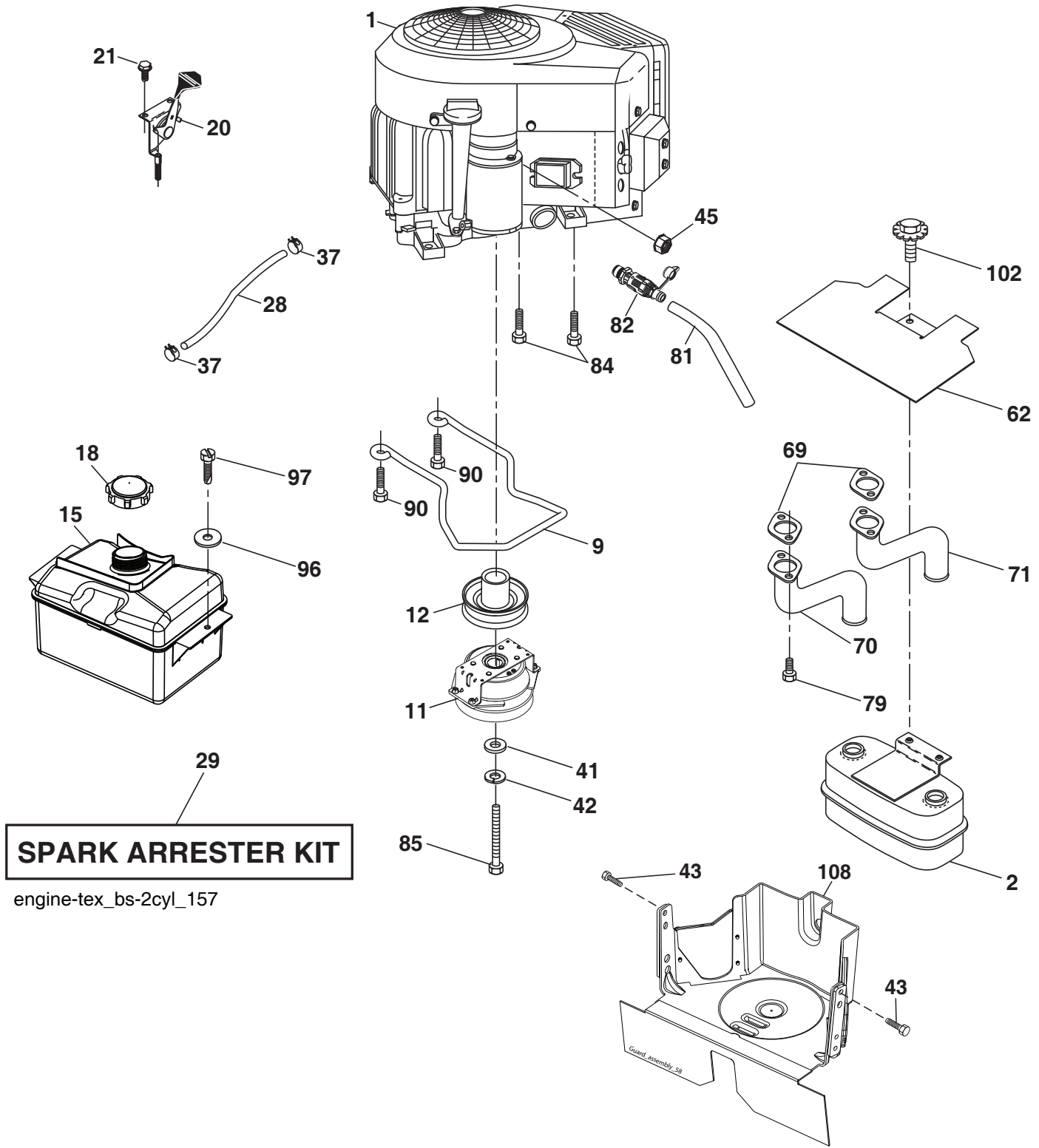

SPARK ARRESTER KIT

engine-tex_bs-2cyl_157

**TRACTOR - - MODEL NO. TC 239T (96051018200), PRODUCT NO. 960 51 01-82
ENGINE 24**

KEY NO.	PART NO.	DESCRIPTION
1	- - - - -	Engine B&S Model No. 40U777-0006-B1 (593105201) (Order parts from engine manufacturer.)
2	589 81 87-01	Muffler
9	501 83 26-02	Keeper Belt Engine
11	592 82 17-01	Clutch Electric
12	532 40 50-97	Pulley Engine
15	581 29 01-01	Tank Fuel
18	532 43 02-20	Fuel Cap
20	587 24 25-01	Control Throttle
21	532 41 63-58	Screw # 10 x 0.750
28	532 14 21-58	Fuel Line
29	532 13 71-80	Spark Arrester Kit
37	532 12 34-87	Clamp Hose
41	532 12 61-97	Washer 1-1/2 OD x 15/32 ID x .250
42	539 99 02-47	Washer SLW STD 7/16
43	817 06 05-16	Screw 5/16-18 x 1 SMGML Tap/R
45	873 51 04-00	Nut Keps Hex 1/4-20 unc
62	532 43 40-17	Shield Heat Muffler
69	532 16 53-91	Gasket
70	581 88 11-01	Tube Exhaust LH
71	581 88 10-01	Tube Exhaust RH
79	532 18 39-06	Screw Socket
81	532 14 84-56	Tube Drain Oil Easy
82	532 42 82-87	Valve Oil Drain
84	817 06 06-20	Screw
85	501 60 66-01	Bolt Hex 7/16-20 x 3.75 Gr. 5
90	817 00 06-16	Screw 3/8-16 x 1
96	819 09 14-16	Washer 9/32 x 7/8 x 16 Ga.
97	817 67 04-12	Screw 1/4-20 x 3/4
102	817 00 05-12	Screw 5/16-18 x 3/4
108	587 17 95-10	Cover Pulley Eng. w/SHLD

NOTE: All component dimensions given in U.S. inches
1 inch = 25.4 mm

Engine Power Rating Information

The gross power rating for individual gas engine models is labeled in accordance with SAE (Society of Automotive Engineers) code J1940 (Small Engine Power & Torque Rating Procedure), and rating performance has been obtained and corrected in accordance with SAE J1995 (Revision 2002-05). Torque values are derived at 3060 RPM; horsepower values are derived at 3600 RPM. Actual gross engine power will be lower and is affected by, among other things, ambient operating conditions and engine-to-engine variability. Given both the wide array of products on which engines are placed and the variety of environmental issues applicable to operating the equipment, the gas engine will not develop the rated gross power when used in a given piece of power equipment (actual "on-site" or net power). This difference is due to a variety of factors including, but not limited to, accessories (air cleaner, exhaust, charging, cooling, carburetor, fuel pump, etc.), application limitations, ambient operating conditions (temperature, humidity, altitude), and engine-to-engine variability. Due to manufacturing and capacity limitations, Briggs & Stratton may substitute an engine of higher rated power for this Series engine.

TRACTOR - - MODEL NO. TC 239T (96051018200), PRODUCT NO. 960 51 01-82
STEERING ASSEMBLY [41]

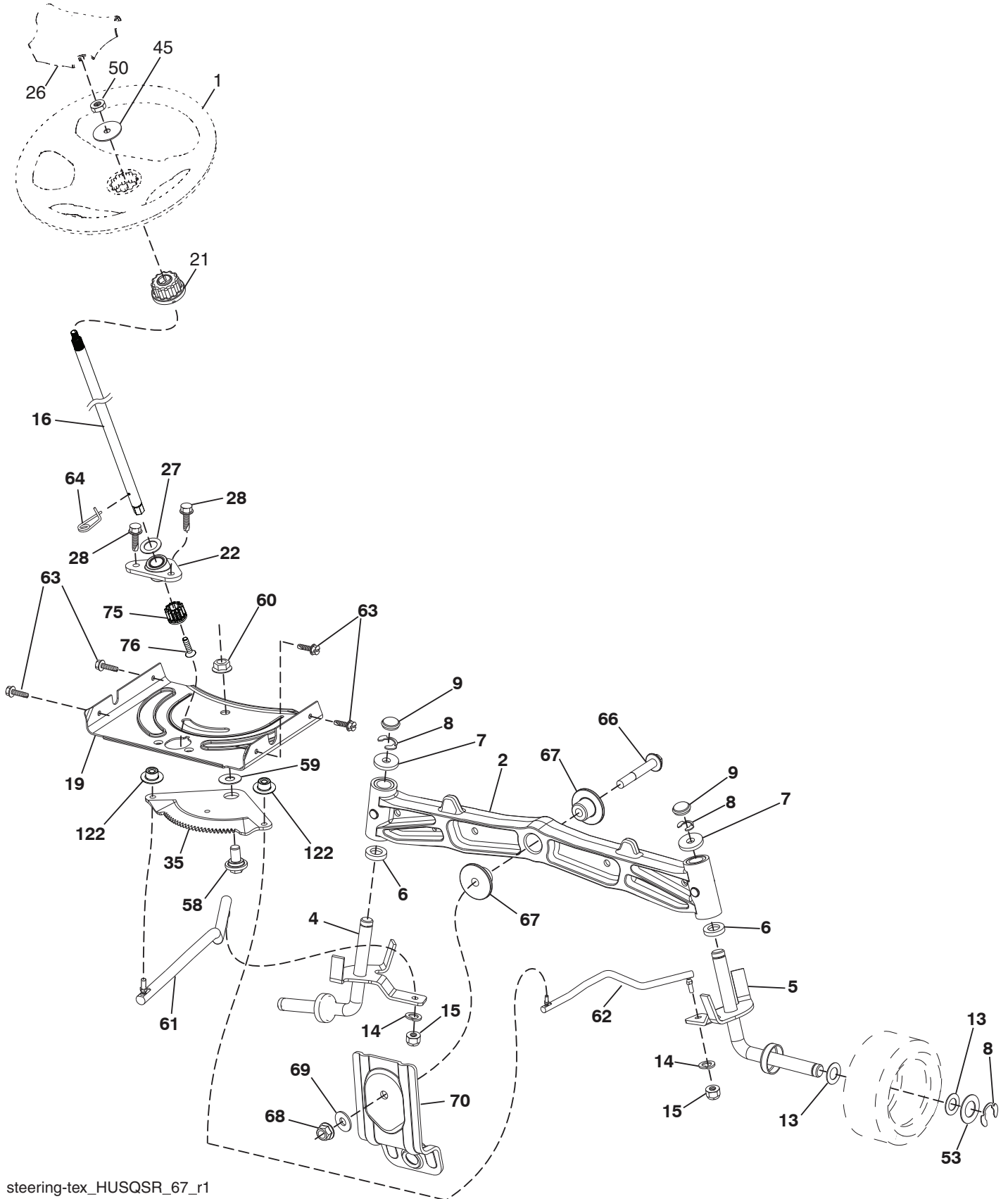

steering-tex_HUSQSR_67_r1

**TRACTOR - - MODEL NO. TC 239T (96051018200), PRODUCT NO. 960 51 01-82
STEERING ASSEMBLY 41**

KEY NO.	PART NO.	DESCRIPTION
1	532 43 97-40	Wheel, Steering
2	532 19 59-68	Axle Cast Iron
4	532 40 30-87	Spindle Asm., LH
5	532 40 30-88	Spindle Asm., RH
6	532 12 49-31	Washer Thrust 0.75 x 1.23
7	532 12 17-48	Washer 25/32 x 1-5/8 x 16 Ga.
8	812 00 00-29	Ring, Klip #T5304-75
9	532 12 12-32	Cap, Spindle
13	532 12 17-49	Washer 25/32 x 1-1/4 x 16 Ga.
14	539 99 01-18	Washer, SLW ZD 3/8
15	873 54 06-00	Nut, Crown Lock 3/8-24 unf
16	587 01 60-02	Shaft Steering
19	532 19 47-29	Plate Steering
21	586 84 02-01	Adapter, Wheel Steering Splnd Alum
22	585 02 98-02	Bearing Shaft Steer Low
26	532 43 97-43	Insert, Wheel Steering
27	819 21 16-16	Washer 21/32 x 1 x 16 Ga.
28	817 00 06-12	Screw 3/8-16 x 3/4
35	532 19 47-32	Gear, Sector Plate
45	587 01 64-01	Washer 3/8 ID 2-3/8 OD 12 Ga. PLTD
50	873 90 06-00	Nut Lock Flg. 3/8-16 unc
53	532 18 89-67	Washer Hardened .793 x 1.637 x .060
58	532 19 47-47	Bolt Shoulder Sector Pivot CFM
59	532 19 47-48	Washer Thrust Sector Steering
60	873 97 10-00	Nut Flange Lock 5/8-11
61	588 79 44-02	Draglink, LH
62	588 79 45-02	Draglink, RH
63	817 00 05-12	Screw 5/16-18 x 3/4
64	532 19 98-49	Retainer Clip Spring Steering
66	871 02 07-48	Bolt Hex Fghd 7/16-14 x 3 Serr
67	532 19 47-37	Bushing PM Front Axle
68	873 90 07-00	Nut Lock Flange 7/16-14 Gr. 5
69	532 19 91-62	Washer 1.5 x .505 x .118
70	585 33 88-01	Bracket Deck Susp. Front
75	580 68 37-01	Pinion
76	580 68 36-01	Screw Head Sock
122	532 44 49-62	Cap Gear

NOTE: All component dimensions given in U.S. inches
1 inch = 25.4 mm

TRACTOR - - MODEL NO. TC 239T (96051018200), PRODUCT NO. 960 51 01-82
 MOWER DECK **44**

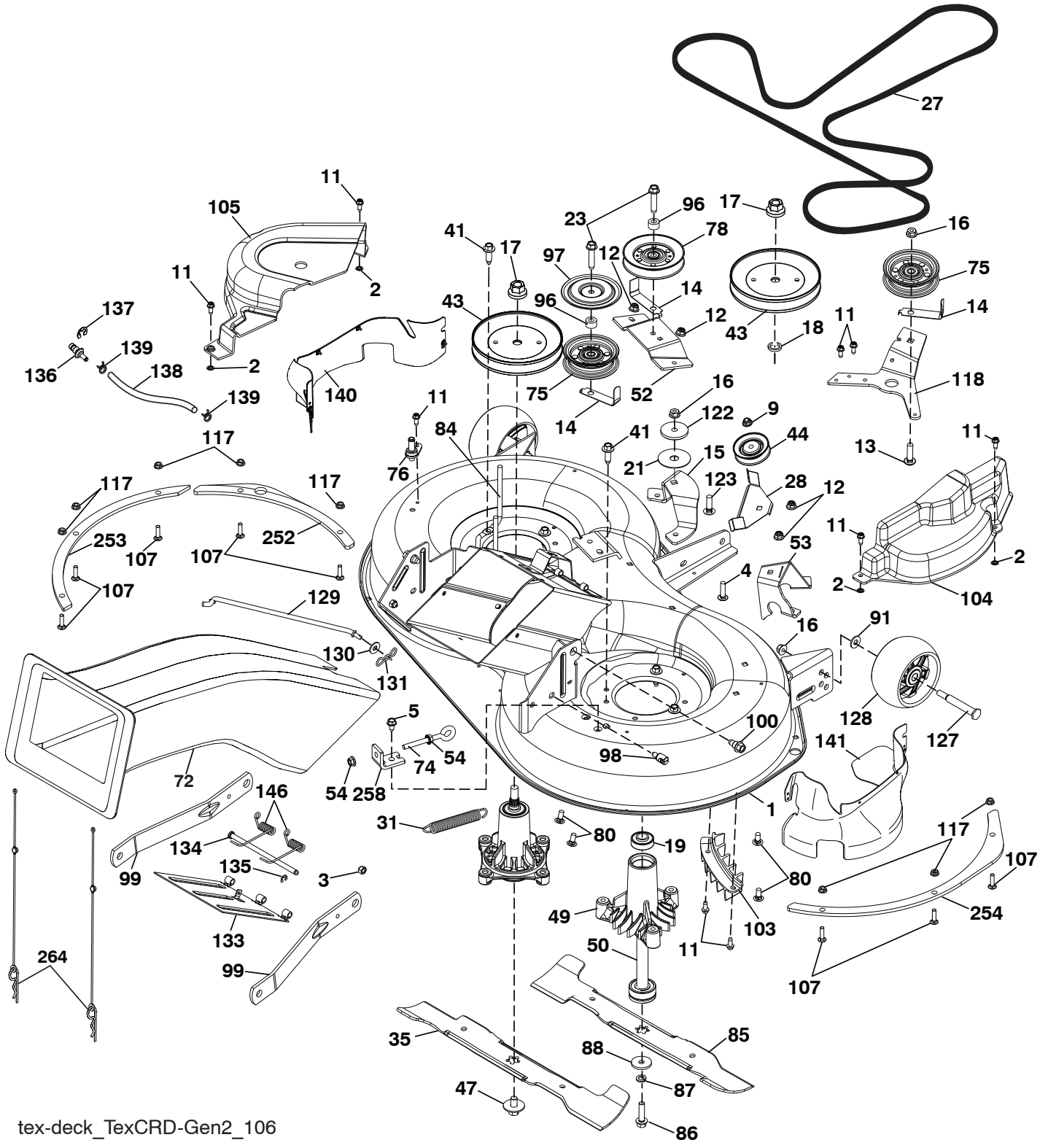

tex-deck_TexCRD-Gen2_106

**TRACTOR - - MODEL NO. TC 239T (96051018200), PRODUCT NO. 960 51 01-82
MOWER DECK 44**

KEY NO.	PART NO.	DESCRIPTION	KEY NO.	PART NO.	DESCRIPTION
1	592 87 42-02	97 Crd Shell Weldment	91	819 12 14-14	Washer 5/16 Flat Ste Std Zd
2	532 42 30-62	Palnut 1/4	96	532 40 02-71	Spacer
3	873 90 05-00	Nut 5/16-18	97	532 18 20-61	Shield Idler Mower
4	872 11 05-10	Bolt Carr. 5/16-18 x 1-1/4 Gr.5	98	532 19 51-61	Stud Fastener
5	817 00 05-10	Bolt 5/16-18	99	532 19 51-86	Arm Suspension
9	585 69 13-01	Nut Hex Flg Nylock	100	532 19 65-39	Bolt Shoulder
11	532 13 77-29	Screw 1/4-20 x 5/8	103	532 43 69-92	Guard Front Vent
12	539 11 28-99	Nut 5/16-18 Hex Flange Nyloc	104	592 84 81-01	Mandrel Cover RH
13	872 11 06-12	Bolt 3/8-16 x 1-1/2	105	532 43 87-44	Mandrel Cover LH
14	532 15 60-85	Keeper Belt Idler	107	592 80 78-01	Bolt 1/4-20 x 3/4
15	592 85 47-02	Crd Idler Arm Mount Bracket	117	873 90 04-00	Nut 1/4-20
16	873 90 06-00	Nut 3/8-16	118	592 85 48-02	Arm Clutching
17	532 40 02-34	Nut Flange 9/16	122	532 16 57-23	Retainer Spacer
18	532 18 76-90	Washer Spacer Mandrel	123	872 11 06-10	Carriage Bolt 3/8-16 x 1.25
19	585 32 39-01	Bearing Mandrel	127	532 19 34-06	Bolt 3/8-16 x 3-5/8
21	532 17 85-15	Washer Flat Hardened	128	589 52 73-01	Wheel Gauge Rally
23	817 49 06-28	Screw 3/8-16 x 1-3/4	129	532 44 32-37	Rod Anti Sway
27	592 86 91-01	Belt 97 Manual	130	819 13 13-12	Washer 13/32 x 13/16 x 12 Ga.
28	592 85 56-02	Keeper 97 Crd Angled Idler	131	532 19 42-08	Pin Cotter 5/16 Bow Tie Lock
31	587 35 84-01	Spring Extn	133	532 43 55-38	Door, Mulch
35	532 42 79-84	Blade	134	532 43 58-61	Pin, Hinge
41	584 95 39-01	Bolt Hex Wshrhd 3/16-18 x 1.19	135	532 43 79-88	E-Ring 5/16
43	532 19 97-89	Pulley Mandrel	136	532 43 96-39	Washout Port Hookup
44	532 19 95-34	Pulley V-Idler Grnd Dr Plated	137	812 00 00-29	Ring Klip
47	584 30 93-01	Screw LH Blade 7/16 x 1	138	532 44 07-43	Hose 3/8 Long 12"
49	532 18 72-81	Housing Mandrel	139	532 44 07-42	Hose 3/8 Clamp
50	587 25 65-01	Shaft Asm	140	501 57 94-01	Guard Asm LH
52	595 09 80-03	Bracket V-Idler Bolt Center	141	501 57 93-01	Guard Asm RH
53	595 09 81-03	Bracket V-Idler Bolt Angled	146	532 44 58-96	Spring, Mulch
54	539 99 05-85	Nut Whizlock 5/16-18	252	585 30 87-05	Plate Reinforcement LHS
72	581 45 41-03	Chute Upper	253	585 30 88-05	Plate Reinforcement LHS
74	539 11 55-74	Bolt Eye 5/16-18 x 3.5	254	585 30 90-05	Plate Reinforcement LHS
75	532 17 34-38	Pulley Idler Flat	258	592 85 60-01	Bracket Adj Tensioner
76	532 43 96-40	Washout Port	264	589 39 29-01	Retainer Chute Texcrd
78	532 17 39-02	Pulley Idler V-GR Plated 4.25	--	587 25 33-01	Mandrel Asm
80	539 99 03-16	Carriage Bolt 5/16-18 3/4	--	597 00 10-01	Replacement Mower Complete
84	532 40 01-40	Keeper Belt Mandrel			
85	532 42 79-85	Blade			
86	532 18 17-13	Bolt 3/8-24 x 1.50			
87	539 99 01-18	Washer Lock			
88	532 14 02-96	Washer Hard Blade			

NOTE: All component dimensions given in U.S. inches
1 inch = 25.4 mm

TRACTOR - - MODEL NO. TC 239T (96051018200), PRODUCT NO. 960 51 01-82
MOWER LIFT 45

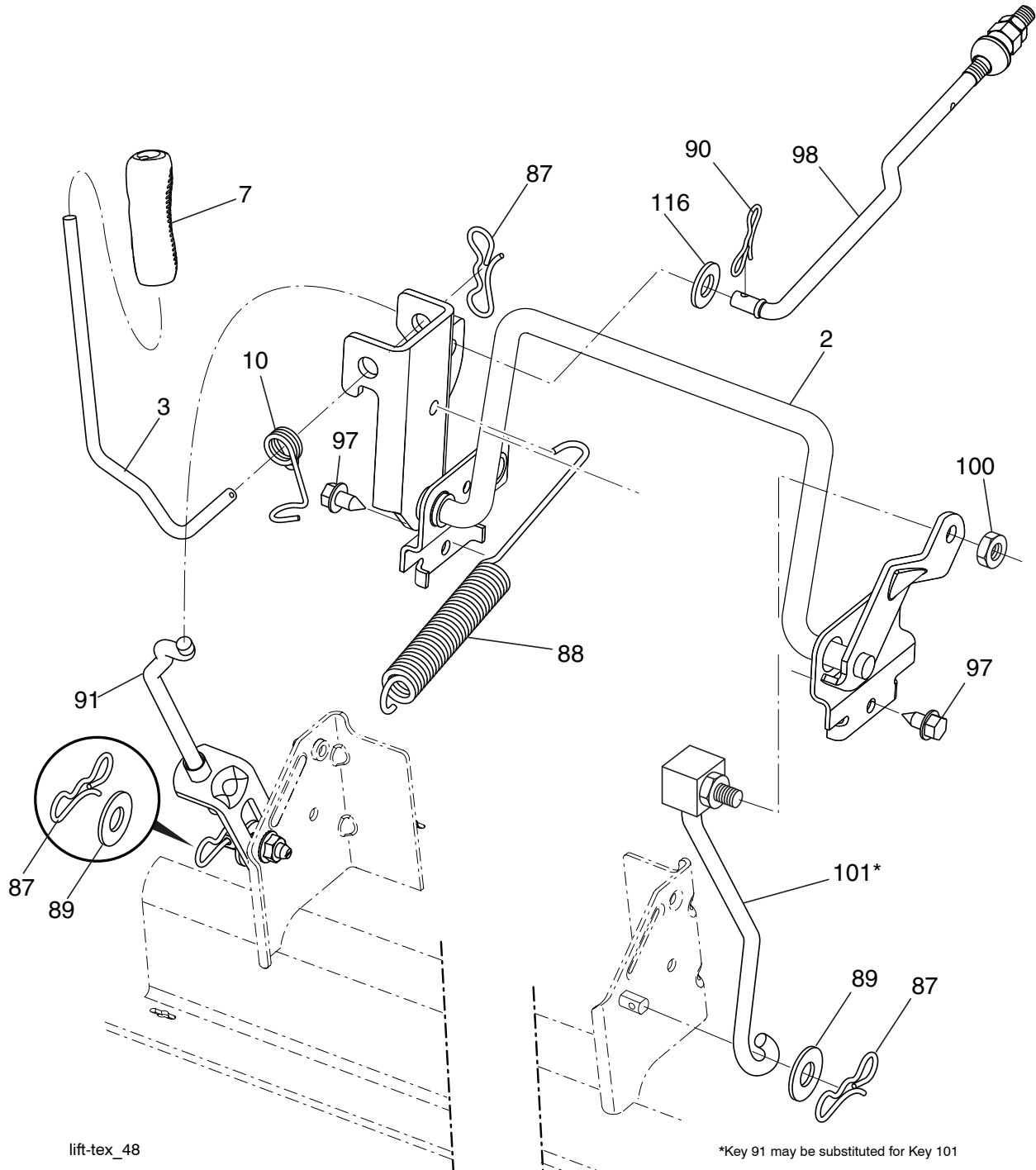

lift-tex_48

*Key 91 may be substituted for Key 101

KEY NO.	PART NO.	DESCRIPTION
2	532 43 69-96	Deck Lift Weldment
3	532 19 52-31	Lever Asm., Lift RH
7	580 96 23-01	Grip, Lever
10	532 19 63-14	Spring Torsion
87	532 19 42-09	Pin Cotter 7/16 Bow Tie Lock
88	532 44 54-96	Spring Lift Assist
89	819 19 19-12	Washer Clear Zinc
90	532 19 42-08	Pin Cotter 5/16 Bow Tie Lock
91	532 19 51-81	Link Lift Susp Mower Rear

KEY NO.	PART NO.	DESCRIPTION
97	817 49 06-08	Screw 3/8-16 x 1/2
98	532 19 52-70	Link Lift Susp. Front Mower
100	873 93 06-00	Nut Centerlock 3/8-16 unc
101	532 40 70-03	Link Asm. Lift Fixed
116	819 15 15-16	Washer 15/32 x 15/16 x 16 Ga.

NOTE: All component dimensions given in U.S. inches
 1 inch = 25.4 mm

**TRACTOR - - MODEL NO. TC 239T (96051018200), PRODUCT NO. 960 51 01-82
SEAT ASSEMBLY 42**

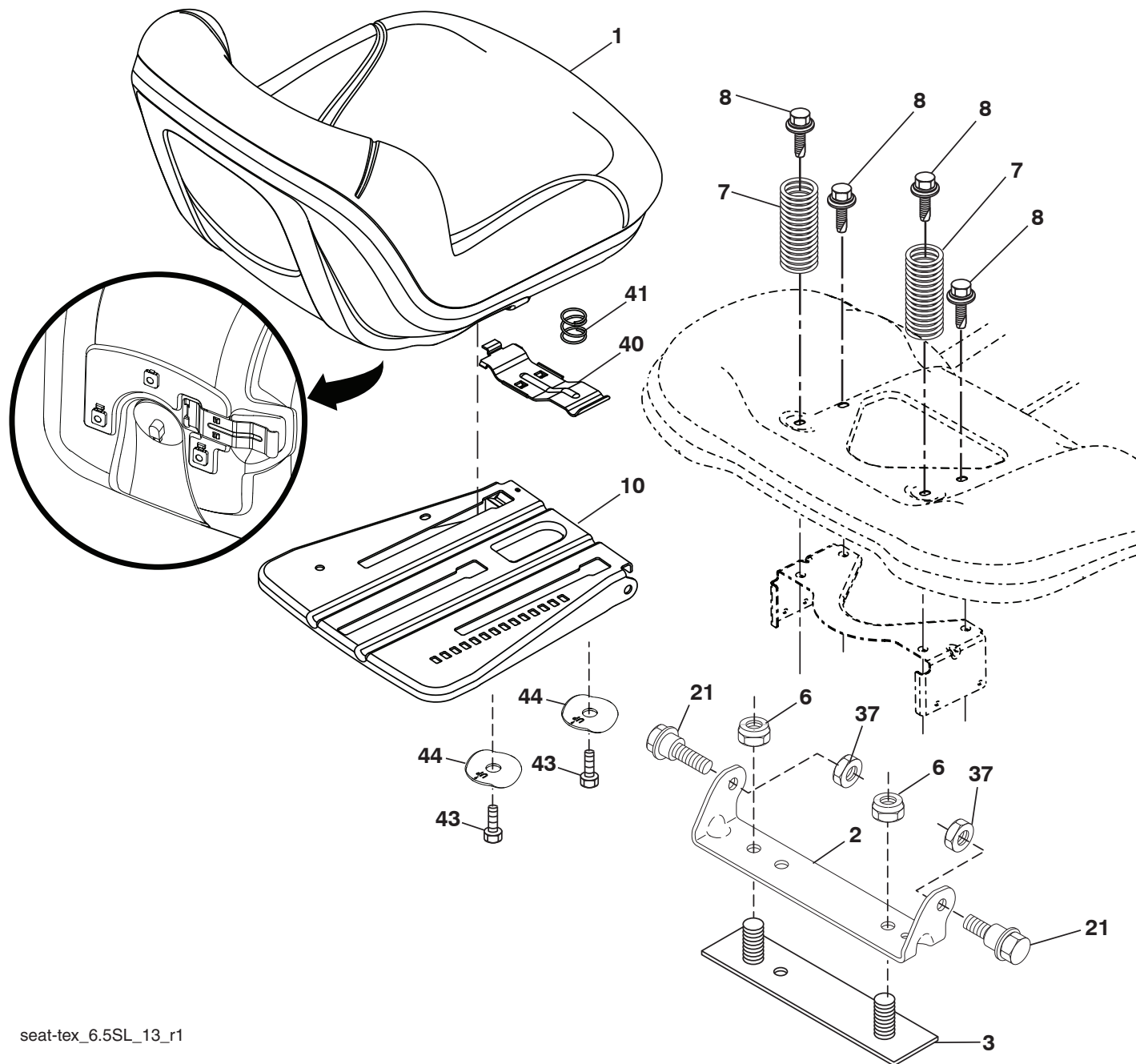

seat-tex_6.5SL_13_r1

KEY NO.	PART NO.	DESCRIPTION
1	532 43 98-22	Seat
2	532 18 01-66	Bracket Pivot Fender
3	532 14 06-75	Strap, Asm Fender
6	873 80 06-00	Nut, Lock W/Ins. 3/8-16 unc
7	589 48 35-01	Spring, Seat Cprsn
8	532 17 18-77	Bolt 5/16-18 unc x 3/4 w/Sems
10	587 23 20-02	Pan, Seat
21	587 90 78-01	Bolt, Shoulder 5/16-18 x 5/8
37	873 80 05-00	Nut, Lock 5/16-18 unc

KEY NO.	PART NO.	DESCRIPTION
40	532 19 76-61	Handle Slide Seat
41	532 19 82-00	Spring Latch Seat
43	874 76 06-12	Bolt Fin Hex 3/8-16 unc x 3/4
44	501 05 18-01	Washer Winged 3/8 ID 1.5 OD

NOTE: All component dimensions given in U.S. inches
1 inch = 25.4 mm

TRACTOR - - MODEL NO. TC 239T (96051018200), PRODUCT NO. 960 51 01-82
BAGGER **46**

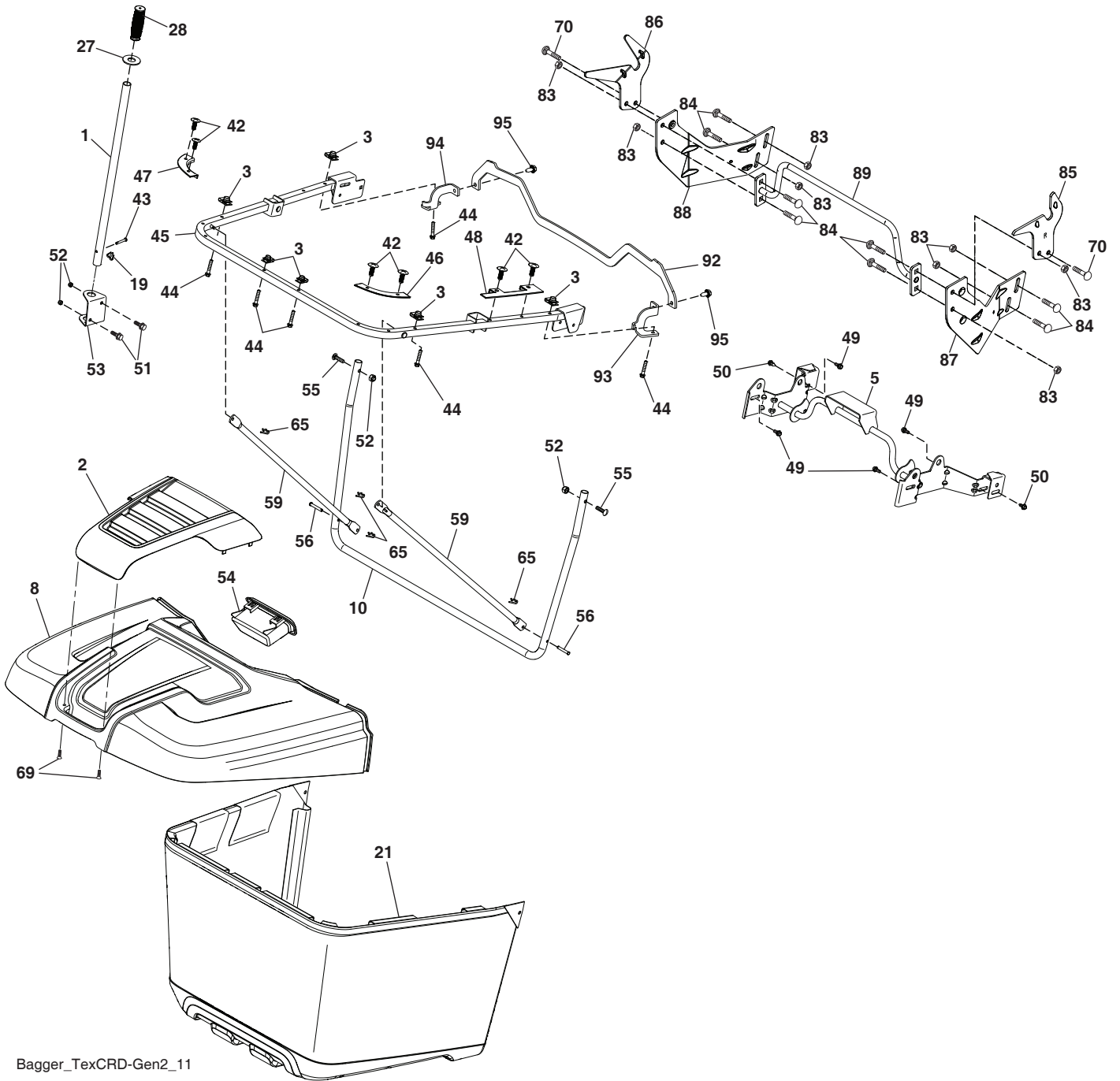

Bagger_TexCRD-Gen2_11

**TRACTOR - - MODEL NO. TC 239T (96051018200), PRODUCT NO. 960 51 01-82
BAGGER 46**

KEY NO.	PART NO.	DESCRIPTION
1	532 42 86-10	Tube Handle Bagger
2	532 44 75-72	Applique
3	532 17 48-14	Palnut 1/4 Lugs
5	532 44 37-62	Upper Pivot Tube
8	532 44 75-75	Bagger Top
10	532 44 37-55	Frame Front
19	532 19 42-08	Cotter Pin 5/16 Bow Tie
21	581 33 71-03	Bag Asm
27	532 44 55-29	Grommet Rubber
28	532 16 57-87	Grip Handle
42	532 44 04-28	Clip
43	532 12 68-75	Clevis Pin
44	532 19 96-87	Bolt 1/4-20
45	532 44 37-54	Upper Frame
46	532 44 55-41	Bag Corner Close Out RH
47	532 44 40-79	Bag Corner Close Out LH
48	532 44 40-80	Top Bagger Side Close Out
49	532 17 18-73	Bolt Shoulder 5/16-18
50	532 17 18-77	Bolt 5/16-18 x 3/4 w/SEMS
51	872 05 05-06	Bolt 5/16 x 18 x 3/4
52	873 80 05-00	Nut Lock Hex w/Ins 5/16-18 unc
53	532 44 41-95	Bracket Dump Handle
54	532 44 72-18	Bagger Top Front Handle
55	539 10 29-33	Bolt 5/16-18 x 1-1/2 Gr. 5
56	532 42 03-06	Pin Clevis .183 x 1.26
59	532 44 47-63	Bagger Sprd Tube
65	532 12 47-88	Retainer Spring
69	532 42 18-01	Screw #8 Flat Head Drill
70	817 00 06-12	Screw 3/8-16 x 3/4
83	873 80 06-00	Nut Lock Hex w/Ins. 3/8-16 unc
84	872 11 06-08	Bolt 3/8-16 x 1 Gr. 5
85	581 31 44-02	Bracket RH Pivot
86	581 31 43-02	Bracket LH Pivot
87	581 31 48-02	Bracket RH
88	581 31 47-02	Bracket LH
89	581 31 51-04	Weldment Offset Strut
92	586 05 23-02	Bracket Top Support
93	586 05 24-02	Bracket Support RH
94	586 05 25-02	Bracket Support LH
95	817 00 05-12	Screw 5/16-18 x 3/4
--	501 70 56-01	Bagger Dump Kit (Includes Key#'s 85, 86, 87, 88, & 89)
--	586 74 49-01	Bagger Complete Kit (Includes Key#'s 1, 5, 10, 19, 21, 27, 28, 42, 43, 46, 47, 48, 49, 50, 52, 54, 56, 59, 65)

NOTE: All component dimensions given in U.S. inches
1 inch = 25.4 mm

