

# ILLUSTRATED PARTS LIST

**MFG. ID NO. 96051018500**

**CUSTOMER CATALOG NO. TC 238**

**PRODUCT NO. 960 51 01-85**

**47**

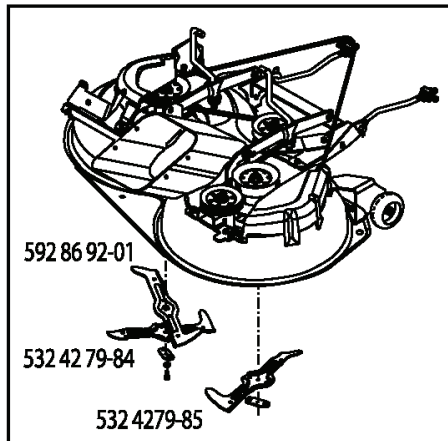
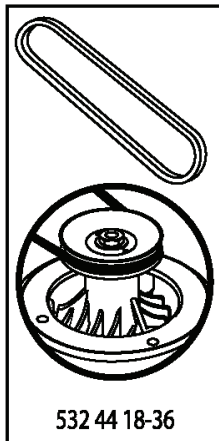
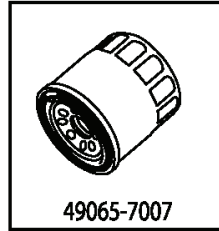
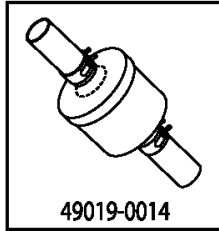
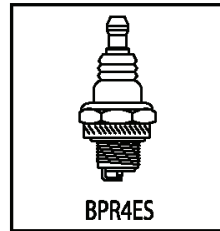
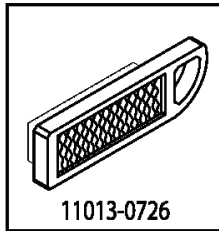

**596555201**

**TRACTOR - - MODEL NO. TC 238 (96051018500), PRODUCT NO. 960 51 01-85  
DECALS 27**

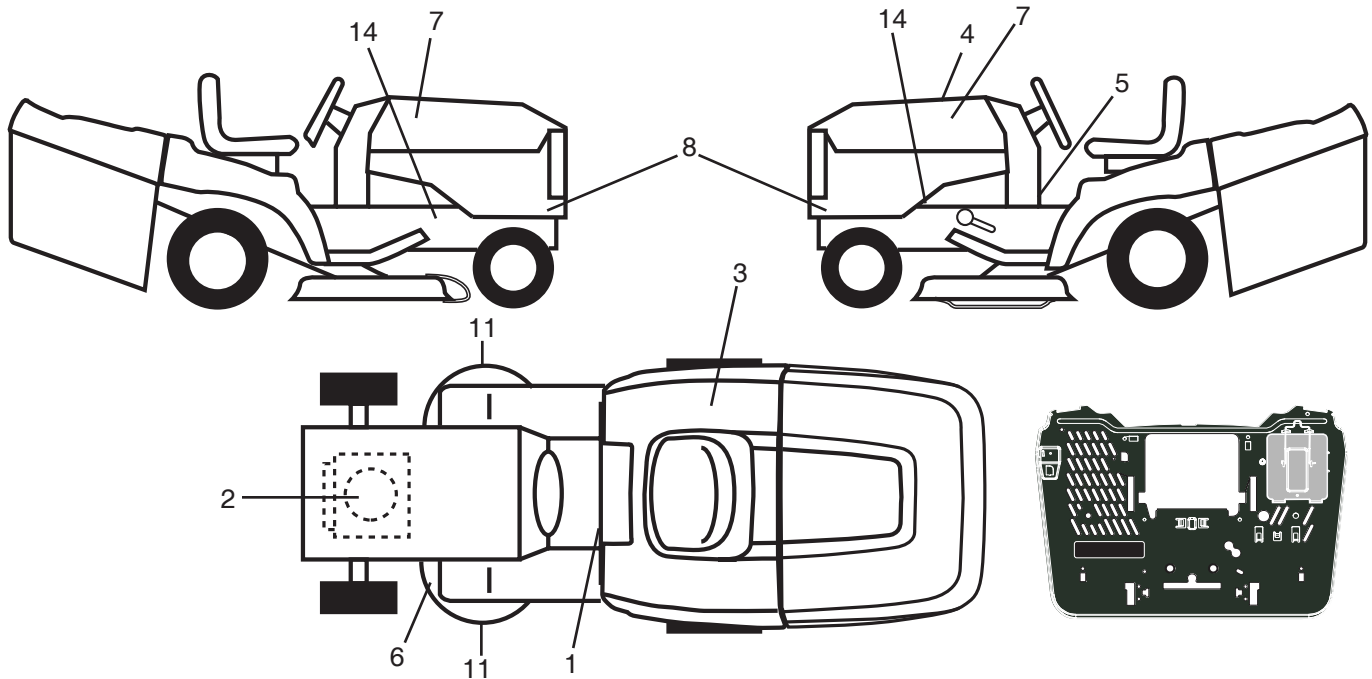

KEY NO.	PART NO.	DESCRIPTION
1	586 04 73-02	Decal, Saddle
2	581 57 97-01	Decal, Warning Eng. Sym.
3	501 08 26-01	Decal, ECM Australia
4	596 55 52-01	Decal, Replacement
5	581 57 84-01	Decal, Mulch Bag Instructions
6	592 98 02-01	Decal, VBelt
7	581 62 73-01	Decal, Hood
8	588 72 58-01	Decal, Side Panel

KEY NO.	PART NO.	DESCRIPTION
11	581 57 91-01	Decal, Mower Cut Finger Symbol
14	581 57 96-01	Decal, Chassis Hot Muffler
--	532 44 54-93	Decal, Warning Combined
--	532 44 46-19	Decal Bypass
--	532 44 14-09	Pad Footrest LH
--	532 44 14-10	Pad Footrest RH
--	114 07 21-27	Manual Operator's (English)

**WHEELS AND TIRES**

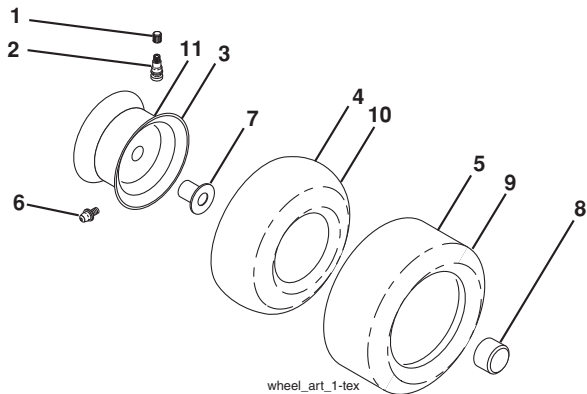

KEY NO.	PART NO.	DESCRIPTION
1	532 05 91-92	Cap Valve Tire
2	532 06 51-39	Stem Valve
3	532 13 83-36	Rim Front
4	532 05 99-04	Tube Front (Service Item Only)
5	532 10 62-22	Tire Front 15 x 6-6
6	532 00 02-78	Fitting Grease (Front Wheel Only)
7	532 00 90-40	Bearing Flange (Front Wheel Only)
8	532 17 50-39	Cap Axle Blk 1 50 x 1 00
9	532 42 05-31	Tire Rear 18 x 9.5-8
10	532 00 71-52	Tube Rear (Service Item Only)
11	532 13 83-37	Rim Asm 8" Rear
--	532 14 43-34	Sealant, Tire (10 oz. Tube)

**NOTE:** All component dimensions given in U.S. inches  
1 inch = 25.4 mm

# TRACTOR - - MODEL NO. TC 238 (96051018500), PRODUCT NO. 960 51 01-85

## SCHEMATIC **38**

SCH19

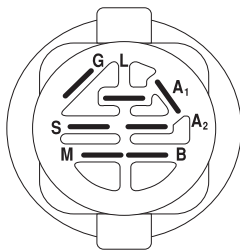
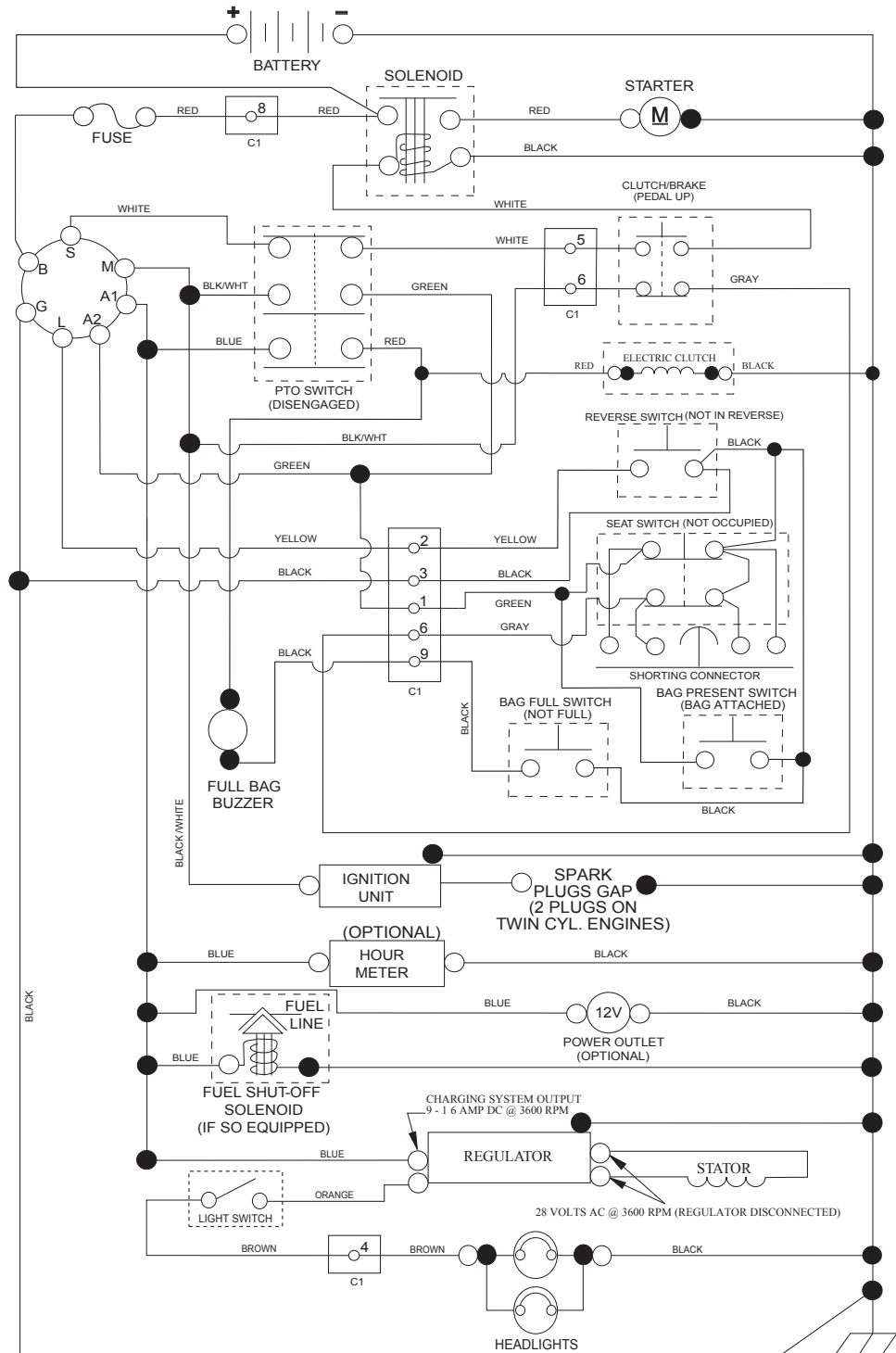

IGNITION SWITCH

POSITION	CIRCUIT	"MAKE"
OFF	M+G+A1	
RUN/OVERRIDE	B+A1	
RUN	B+A1	L+A2
START	B + S + A1	

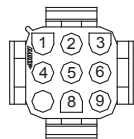

CHASSIS HARNESS CONNECTOR (C1) (MATING SIDE)

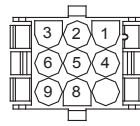

DASH HARNESS CONNECTOR (C1) (MATING SIDE)

WIRING INSULATED CLIPS  
NOTE: IF WIRING INSULATED CLIPS WERE REMOVED FOR SERVICING OF UNIT, THEY SHOULD BE RE-INSTALLED TO PROPERLY SECURE YOUR WIRING.

NON-REMOVABLE CONNECTIONS

REMOVABLE CONNECTIONS

**TRACTOR - - MODEL NO. TC 238 (96051018500), PRODUCT NO. 960 51 01-85**  
**ELECTRICAL 32**

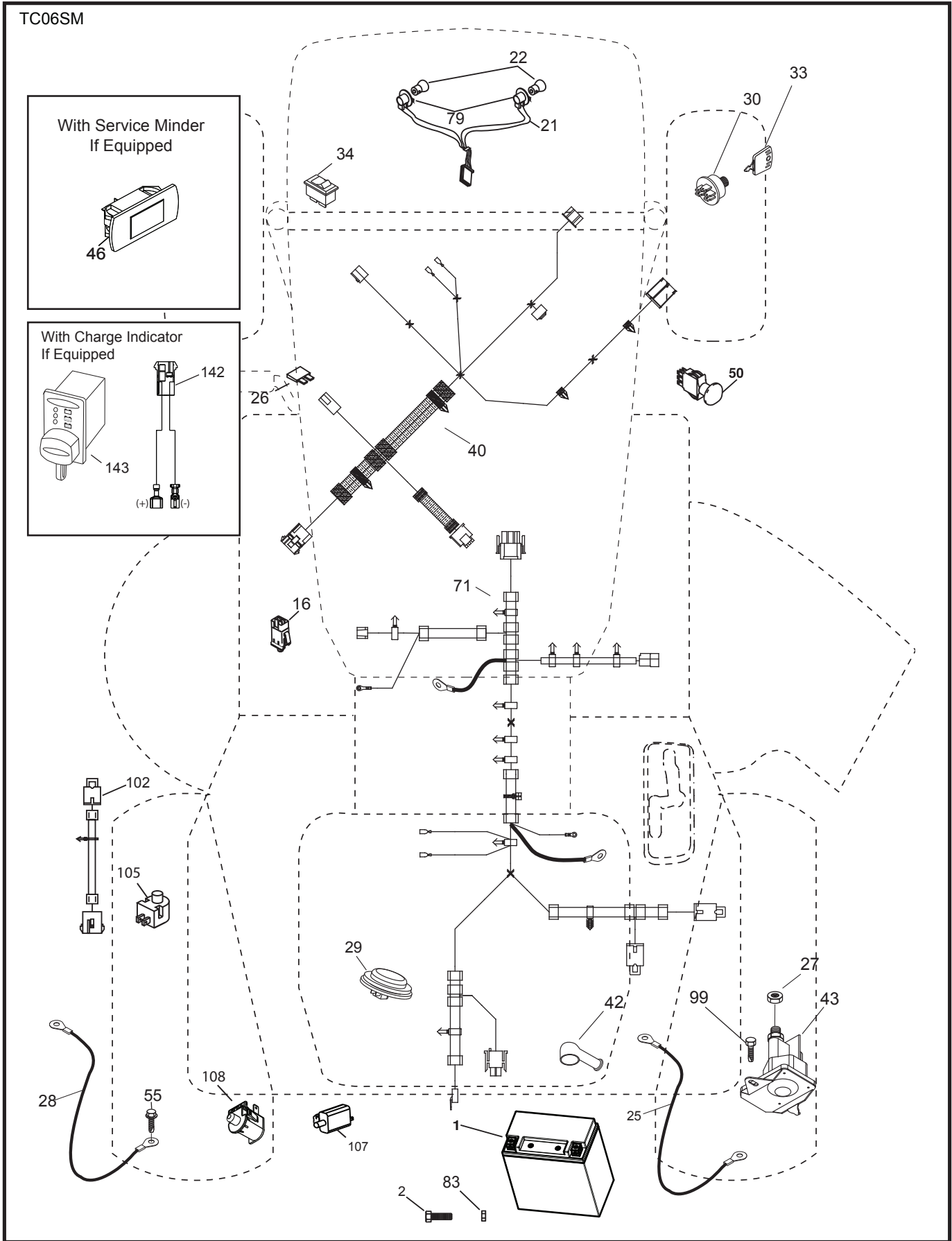

**TRACTOR - - MODEL NO. TC 238 (96051018500), PRODUCT NO. 960 51 01-85  
ELECTRICAL 32**

<b>KEY NO.</b>	<b>PART NO.</b>	<b>DESCRIPTION</b>
1	532 43 71-57	Battery
2	532 44 09-23	Screw Hex Hd Cap M6 x 1.12mm
16	532 17 61-38	Switch Interlock Push-In
21	532 40 02-52	Harness Light
22	532 00 41-52	Bulb Light
25	589 32 37-01	Cable Battery
26	532 17 51-58	Fuse
27	873 51 04-00	Nut Keps Hex 1/4-20 unc
28	589 32 36-01	Cable, Ground
29	532 40 15-45	Switch, Seat
30	532 19 33-50	Switch, Ign
33	532 41 19-33	Key/Chain
34	532 11 07-12	Switch Light
40	587 26 89-01	Harness Ign. Dash
42	532 13 15-63	Cover Terminal Red
43	582 04 28-01	Solenoid
46	594 91 91-01	Hourmeter
50	582 10 76-01	Switch PTO
55	817 06 05-12	Screw Thdrol 5/16-18 x 3/4 TYTT
71	532 44 08-20	Harness Ignition Chassis
79	532 17 52-42	Socket Asm. Bulb
83	532 43 67-74	Nut Square M6 x 1.8.5 x 11mm
99	817 00 05-12	Screw 5/16-18 x 3/4
102	532 44 12-62	Harness Jumper
105	532 40 75-68	Switch Reverse
107	532 18 03-79	Switch Full Bagger
108	589 50 03-01	Switch SNPMT.

**NOTE:** All component dimensions given in U.S. inches  
1 inch = 25.4 mm

# TRACTOR - - MODEL NO. TC 238 (96051018500), PRODUCT NO. 960 51 01-85

## CHASSIS AND ENCLOSURES 39

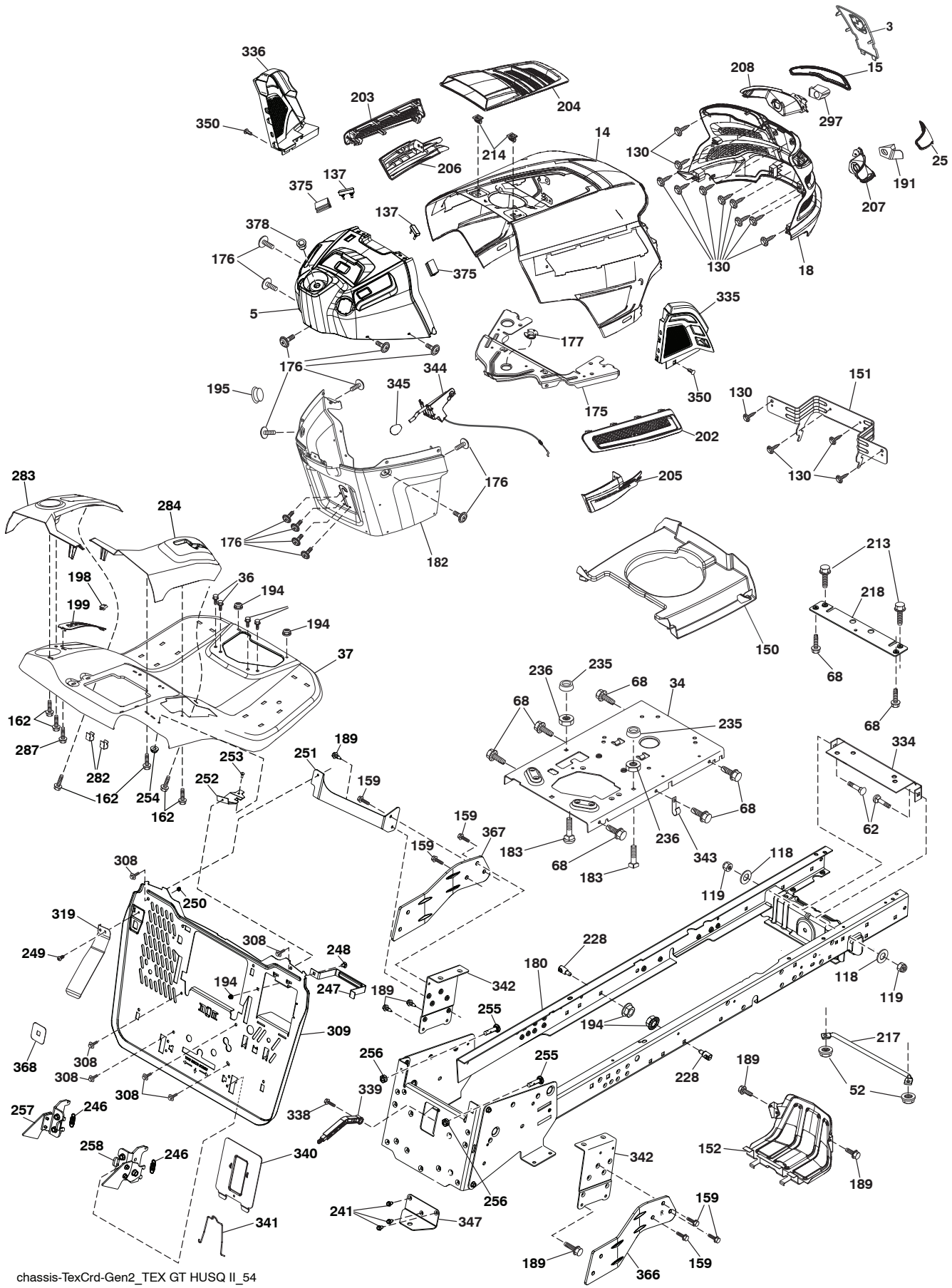

chassis-TextCrd-Gen2\_TEX GT HUSQ II\_54

**TRACTOR - - MODEL NO. TC 238 (96051018500), PRODUCT NO. 960 51 01-85  
CHASSIS AND ENCLOSURES 39**

KEY NO.	PART NO.	DESCRIPTION	KEY NO.	PART NO.	DESCRIPTION
3	532 44 44-81	Applique	236	873 93 05-00	Nut Lock 5/16-18 unc
5	590 74 88-11	Dash	241	817 06 05-16	Screw 5/16-18 x 1
14	532 44 11-77	Hood	246	591 44 90-01	Spring
15	532 43 97-33	Lens LH	247	582 55 26-02	Strap Battery
18	587 52 34-01	Grille	248	872 11 05-04	Bolt Carr. 5/16-unc x 1/2
25	532 44 33-85	Lens RH	249	586 93 60-01	Screw Buttonhead 10-24 x 1/2
34	580 91 09-01	Plate Engine	250	539 97 69-77	Nut #10-24 Hex Nylon Ring
36	817 06 05-12	Screw 5/16-18 x 3/4	251	589 31 89-04	Backplate Support Bracket
37	532 44 14-19	Fender	252	581 99 22-04	Backplate Support Bracket
52	873 68 05-00	Nut Lock 5/16-18	253	539 11 56-20	Bolt Carr. 1/4-20 x 3/4
62	872 11 06-08	Bolt RdHd Sqnk 3/8-16 x 1 Gr. 5	254	873 90 04-00	Nut Hex Flange 1/4-20 unc
68	539 99 08-58	Screw Thdrol 5/16-18 x 1/2	255	589 39 22-03	Bolt Cross Drilled 3.8/16 x 1.75
118	819 13 13-16	Washer 13/32 x 13/16 x 16 Ga.	256	532 19 70-33	Nut Jam 3/8-16
119	873 68 06-00	Nut Crownlock 3/8-16 unc	257	589 74 66-02	Bagger Latch Assembly LH
130	532 41 63-58	Screw #10 x 0.750	258	589 74 67-02	Bagger Latch Assembly RH
137	532 40 75-90	Bumper Dash	282	532 41 41-10	Clip Retainer
150	532 43 97-31	Air Duct	283	532 44 72-12	Console Deck Lift LH
151	532 43 66-70	Bracket Pivot	284	532 44 72-20	Console Shft RH
152	532 43 98-70	Shield Browning	287	817 60 04-06	Screw 1/4-20 x 3/8
159	817 00 06-12	Screw Hexwsh Thrd 3/8-16 x 3/4	297	532 43 74-56	Insert Reflective LH
162	532 14 24-32	Screw	308	532 17 18-77	Bolt 5/16-18 unc x 3/4
175	590 60 77-02	Crossmember	309	582 55 25-02	Backplate
176	532 40 07-76	Screw 10-24 x 5/8	319	581 31 39-07	Lever Bag
177	532 19 52-28	Bushing Steering	334	532 44 25-37	Bracket Engine
180	593 89 88-01	Chassis	335	532 44 82-04	Cover RH Lower Close Out
182	532 43 89-67	Dash Lower	336	532 44 53-09	Cover LH Lower Close Out
183	874 52 05-20	Bolt 5/16-18 x 1-1/4	338	594 09 39-01	Bolt Shoulder
189	817 00 05-12	Screw 5/16-18 x 3/4	339	532 43 66-41	Lever Bagger Full
191	532 43 74-55	Insert Reflective RH	340	582 55 27-02	Door Battery
194	873 90 05-00	Nut Lock Hex Flange 5/16-18	341	582 06 08-01	Latch Battery Door
195	532 40 41-37	Plug Hole Dash Lower	342	582 82 68-02	Supprt Fender
198	532 44 15-52	Indicator Deck Lift	343	532 44 07-49	Clip
199	532 41 87-39	Plate Deck Lift	344	532 43 89-70	Control EZ Mulch
202	532 43 97-28	Vent Side Hood RH	345	532 44 06-39	Knob
203	532 43 97-27	Vent Side Hood LH	347	532 44 28-87	Hitch Tow
204	532 43 57-14	Vent Top Hood	350	532 44 51-43	Clip X-Mas Tree
205	532 43 97-30	Trim Hood Side RH	366	581 31 46-02	Bracket RH Front Bagger
206	532 43 97-29	Trim Hood Side LH	367	581 31 45-02	Bracket LH Front Bagger
207	587 46 48-01	Bezel RH	368	581 42 48-01	Full Lever Shroud
208	587 46 45-01	Bezel LH	375	586 90 82-01	Dash Clip-On Bumper
213	539 97 69-34	Screw 5/16-18 x 3/4	378	590 84 98-01	Bushing Flange
214	532 19 91-45	Clip Retainer Tinner	--	532 40 09-44	Bumper
217	532 40 91-67	Rod Pivot			
218	532 19 63-95	X-Piece Hood Stop			
228	532 19 51-61	Stud Fastner			
235	532 40 61-29	Spacer Fender			

**NOTE:** All component dimensions given in U.S. inches  
1 inch = 25.4 mm

**TRACTOR - - MODEL NO. TC 238 (96051018500), PRODUCT NO. 960 51 01-85**  
**DRIVE 40**

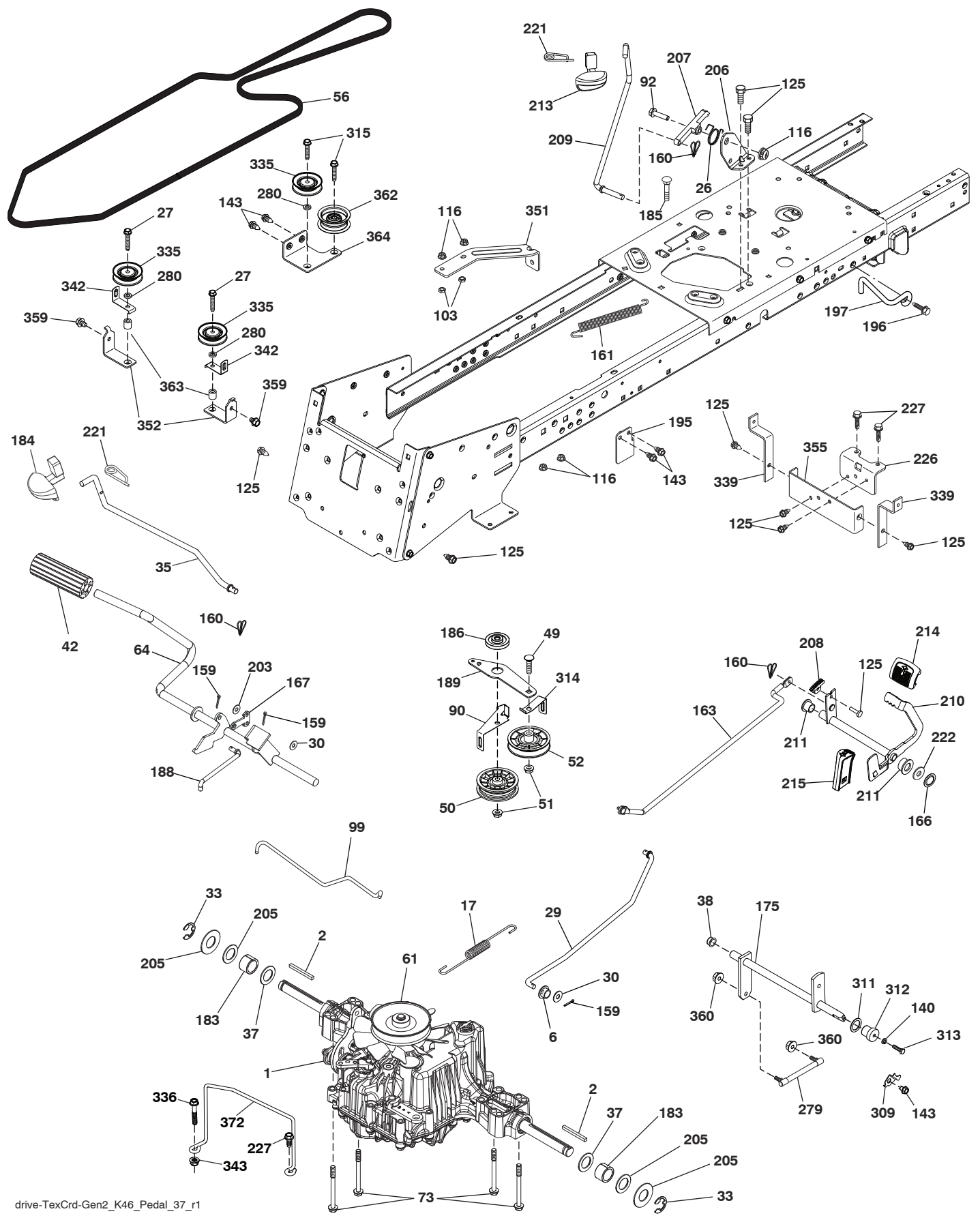

drive-TeXCrd-Gen2\_K46\_Pedal\_37\_r1



**TRACTOR - - MODEL NO. TC 238 (96051018500), PRODUCT NO. 960 51 01-85  
DRIVE **40****

KEY NO.	PART NO.	DESCRIPTION	KEY NO.	PART NO.	DESCRIPTION
1	- - - - -	Transaxle, Tufftorq K46DF (446488) (Order parts from trans-axle manufacturer.)	196	817 00 06-16	Screw 3/8-16x1 SMGML Tap/R Blk
2	532 12 35-83	Key Square	197	585 65 86-01	Link Clutch Anti-Rotation
6	532 12 40-28	Bushing Snap	203	819 11 11-16	Washer 11/32 x 11/16 x 16 Ga.
17	532 43 62-27	Spring Brake K46	205	532 12 17-48	Washer 25/32 x 1-5/8 x 16 Ga.
26	532 19 96-79	Spring Return Cruise	206	532 44 85-96	Bracket Mount Latch Cruise
27	817 49 05-28	Screw Hexwsh Thd 5/16-18 x 1-3/4	207	587 03 14-01	Latch Control Cruise
29	532 44 27-95	Rod, Brake	208	532 19 78-69	Gear Sector Control Cruise
30	819 13 16-16	Washer	209	532 19 95-92	Rod Control Cruise
33	812 00 00-01	Ring E	210	532 40 09-80	Rocker Asm. Pedal Control
35	583 86 45-02	Rod, Brake, Park	211	532 12 01-83	Bearing Nylon
37	532 18 89-67	Washer Harden .793 x 1.063 x .060	213	532 40 31-19	Knob Control Cruise
38	532 16 96-13	Nyliner Bushing	214	532 42 12-63	Pedal Forward
42	532 00 88-83	Cover, Foot Pedal	215	586 60 65-02	Pedal Reverse
49	872 11 06-14	Bolt Rdhd 3/8-16 unc x 3/4 Gr. 5	221	532 40 31-87	Retainer Spring Clip Handle
50	532 19 43-27	Idler Flat	222	879 21 20-10	Washer 21/32 x 1-1/4 10 Ga.
51	873 90 06-00	Lock Nut 3/8-16	226	532 40 15-64	Bracket Strap Torque
52	532 19 43-26	Idler V-Groove	227	817 49 05-12	Screw
56	591 06 53-01	V-Belt, Drive	279	532 44 42-83	Link Shift
61	532 44 51-51	Pulley Transaxle K46	280	819 11 10-12	Washer 11/32 x 5/8 x 12 Ga.
64	532 19 78-65	Shaft Asm. Pedal Brake Control	309	532 16 55-81	Plate Fstnr Cross Shf
73	874 49 05-44	Bolt Flanged	311	532 16 98-45	Washer Nylon
90	532 44 36-05	Keeper Belt Clutching	312	532 16 56-14	Hub Tapered
92	874 76 05-20	Bolt Fin Hex 5/16-18 unc x 1.25	313	874 78 04-16	Bolt Hex Fin 1/4-20 unc x 1 Gr. 5
99	532 44 39-47	Rod Spring Bypass	314	532 44 47-13	Keeper Belt
103	873 35 05-00	Nut Hex Jam 5/16-18	315	817 58 05-20	Screw Thdrol 5/16-18 x 4.25
116	873 90 05-00	Nut Lock Hex Flange 5/16-18	335	532 19 95-34	Pulley V-Idler
125	817 00 05-12	Screw 5/16-18 x 3/4	336	587 25 96-01	Bolt 5/16-18 x 1-3/4 Flanged hex
140	810 04 04-00	Washer Lock Hvy Helical 1/4	339	532 43 68-67	Strap Torque K46 CRD Tex
143	539 99 08-58	Screw 5/16-18 x 1/2	342	532 18 26-82	Keeper Belt 2.5" STL V-Idlr CRD
159	876 02 04-12	Pin Cotter 1/8 x 3/4	343	539 11 28-99	Nut 5/16-18 Hex Flanged Nyloc
160	532 16 94-84	Retainer Clip	351	532 43 69-98	Bracket 97 CRD Deck Sway
161	532 10 57-09	Spring, Return, Clutch	352	532 43 56-45	Bracket Idler CRD Tex
163	532 44 27-93	Rod Control	355	532 43 56-69	Strap Torque
166	532 42 91-64	Nut Push	359	817 49 06-10	Screw Thdrol 3/8-16 x 5/8
167	532 40 52-57	Latch Brake Parking	360	532 44 47-14	Nut 5/16-24 unf
175	532 42 93-59	Shaft Asm Crossshift Rear CRD	362	532 43 68-12	Idler Flat
183	532 13 70-57	Spacer Axle	363	532 44 27-80	Spacer .343 x .63 x .62
184	587 65 37-01	Handle Parking Brake	364	532 44 30-32	Bracket Idler CRD Tex
185	872 11 06-22	Bolt 3/8-16 unc x 2-3/4 Gr. 5	372	582 65 49-01	Keeper Belt Transaxle
186	532 19 43-21	Spacer Retainer			
188	582 21 70-01	Link Clutch			
189	532 43 36-11	Bellcrank Ground Drive			
195	580 45 69-01	Bracket Rod Brake CRD Tex			

**NOTE:** All component dimensions given in U.S. inches  
1 inch = 25.4 mm

TRACTOR - - MODEL NO. TC 238 (96051018500), PRODUCT NO. 960 51 01-85  
ENGINE **24**

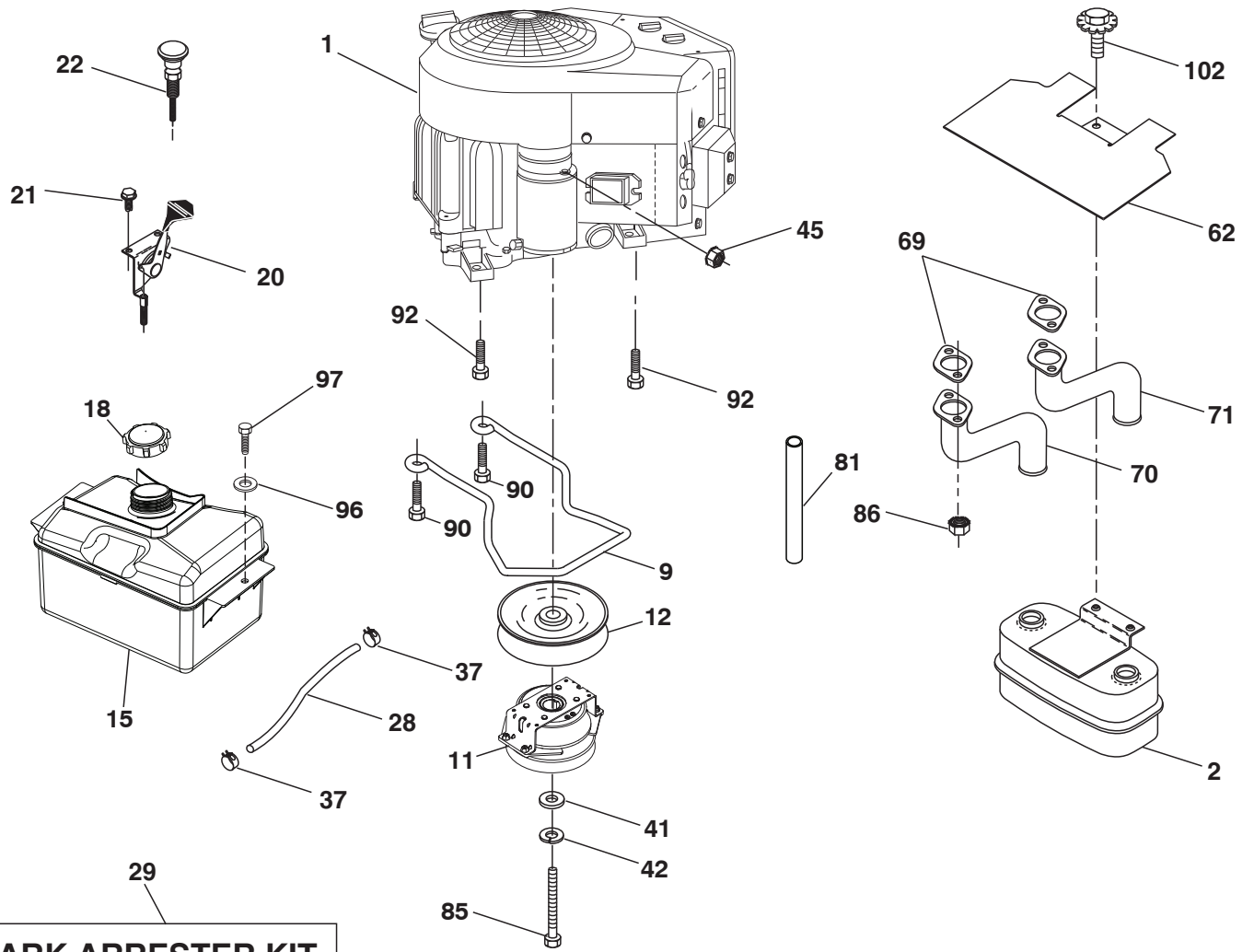

**SPARK ARRESTER KIT**

engine-tex\_Kawa-2cyl\_62

**TRACTOR - - MODEL NO. TC 238 (96051018500), PRODUCT NO. 960 51 01-85  
ENGINE 24**

<b>KEY NO.</b>	<b>PART NO.</b>	<b>DESCRIPTION</b>
1	-- -- -- --	Engine Kawa Model No. FR600V-AS11 (581477001) (Order parts from engine manufacturer.)
2	589 81 87-01	Muffler
9	501 83 26-02	Keeper Belt Engine
11	592 82 17-01	Clutch Ogura
12	532 40 50-97	Pulley Engine
15	581 29 01-01	Tank Fuel
18	532 43 02-20	Cap Asm
20	532 41 21-65	Control Throttle
21	532 41 63-58	Screw # 10 x 0.750
22	532 18 95-41	Choke Control
28	587 04 48-60	Fuel Line
29	532 13 71-80	Spark Arrester Kit
37	532 12 34-87	Clamp Hose
41	532 12 61-97	Washer
42	539 99 02-47	Washer SLW STD 7/16
45	873 51 04-00	Nut Keps Hex 1/4-20 unc
62	532 43 40-17	Shield Heat Muffler
69	532 17 81-51	Gasket
70	583 95 57-01	Tube Exhaust RH
71	583 95 56-01	Tube Exhaust LH
81	532 14 84-56	Tube Drain Oil
85	501 60 66-01	Bolt Hex 7/16-20 x 3.75 Gr 5
86	532 18 43-62	Nut Hex Flange Toplock M8-1.25
90	817 00 06-16	Screw 3/8-16 x 1
92	817 12 06-16	Screw 3/8-16 x 1
96	819 09 14-16	Washer 9/32 x 7/8 x 16 Ga.
97	817 67 04-12	Screw 1/4-20 x 3/4
102	817 00 05-12	Screw 5/16-18 x 3/4

**NOTE:** All component dimensions given in U.S. inches  
1 inch = 25.4 mm

For engine service and replacement parts, call the toll free number for your engine manufacturer listed below:

Kawasaki 1-949-460-5688

**TRACTOR - - MODEL NO. TC 238 (96051018500), PRODUCT NO. 960 51 01-85**  
**STEERING ASSEMBLY 41**

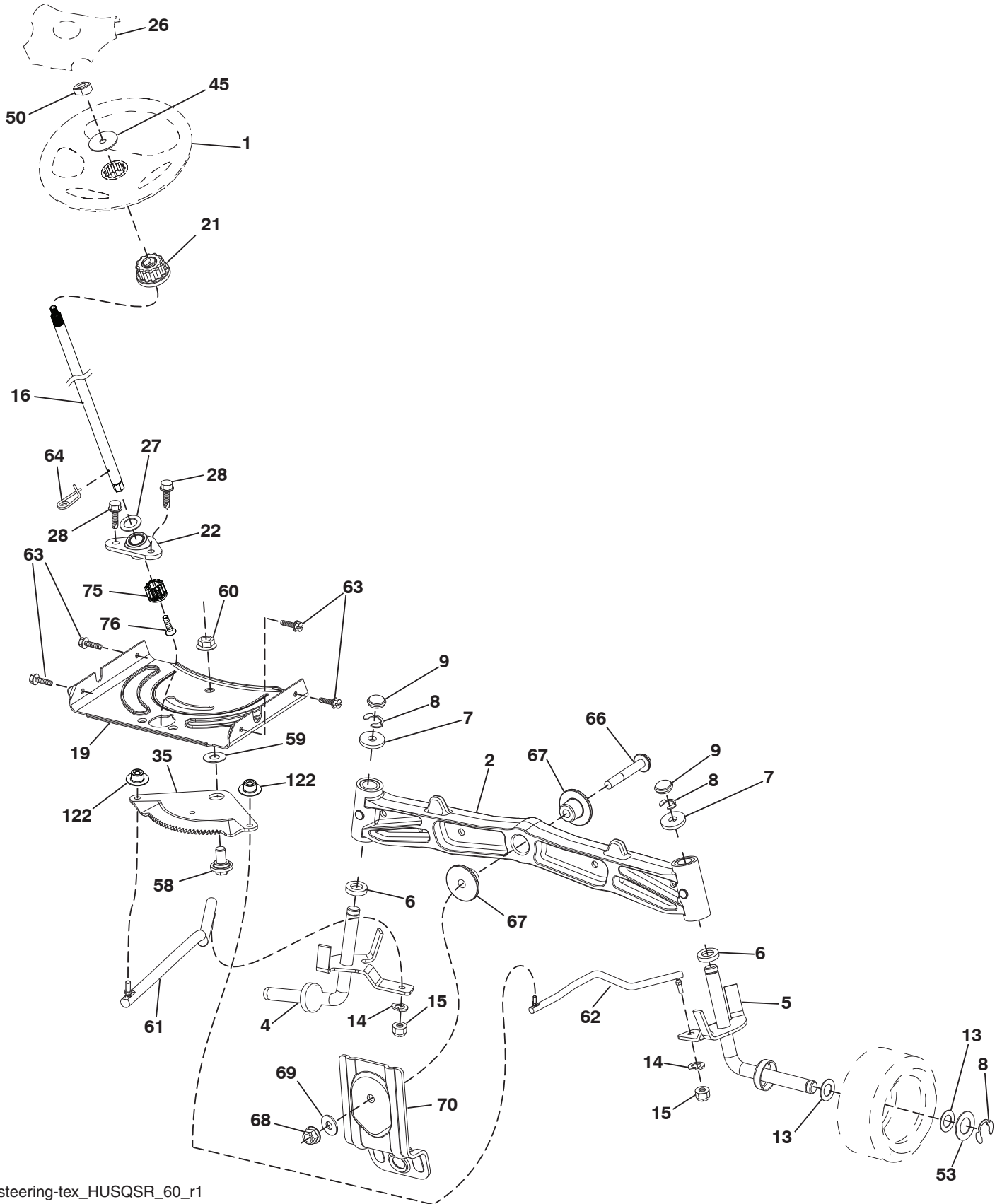

steering-tex\_HUSQSR\_60\_r1

**TRACTOR - - MODEL NO. TC 238 (96051018500), PRODUCT NO. 960 51 01-85  
STEERING ASSEMBLY **41****

<b>KEY NO.</b>	<b>PART NO.</b>	<b>DESCRIPTION</b>
1	532 43 97-40	Wheel, Steering
2	532 19 59-68	Axle Asm., Front
4	532 40 30-87	Spindle Asm., LH
5	532 40 30-88	Spindle Asm., RH
6	532 00 62-66	Washer Thrust 0.75 x 1.23
7	532 12 17-48	Washer 25/32 x 1-5/8 x 16 Ga.
8	812 00 00-29	Ring, Klip #T5304-75
9	532 12 12-32	Cap, Spindle
13	532 12 17-49	Washer 25/32 x 1-1/4 x 16 Ga.
14	539 99 01-18	Washer, SLW ZD 3/8
15	873 54 06-00	Nut, Crown Lock 3/8-24 unf
16	587 01 60-02	Shaft Steering
19	532 19 47-29	Plate Steering
21	586 84 02-01	Adapter, Wheel Steering Splnd Alum
22	585 02 98-02	Bearing Subasm Shaft Steer Low
26	532 43 97-43	Insert, Wheel Steering
27	819 21 16-16	Washer 21/32 x 1 x 16 Ga.
28	817 00 06-12	Screw 3/8-16 x 3/4
35	532 19 47-32	Gear, Sector Plate
45	587 01 64-01	Washer 3/8 ID 2-3/8 OD 12 Ga. PLTD
50	873 90 06-00	Nut Lock Flg. 3/8-16 unc
53	532 18 89-67	Washer Hardened .793 x 1.637 x .060
58	532 19 47-47	Bolt Shoulder Sector Pivot CFM
59	532 19 47-48	Washer Thrust Sector Steering
60	873 97 10-00	Nut Flange Lock 5/8-11
61	588 79 44-02	Draglink, LH
62	588 79 45-02	Draglink, RH
63	817 00 05-12	Screw 5/16-18 x 3/4
64	532 19 98-49	Retainer Clip Spring Steering
66	871 02 07-48	Bolt Hex Fghd 7/16-14 x 3 Serr
67	532 19 47-37	Bushing PM Front Axle
68	873 90 07-00	Nut Lock Flange 7/16-14 Gr. 5
69	532 19 91-62	Washer 1.5 x .505 x .118
70	585 33 88-01	Bracket Deck Susp. Front
75	580 68 37-01	Pinion
76	580 68 36-01	Screw Head Sock
122	532 44 49-62	Cap Gear

**NOTE:** All component dimensions given in U.S. inches  
1 inch = 25.4 mm

TRACTOR - - MODEL NO. TC 238 (96051018500), PRODUCT NO. 960 51 01-85  
MOWER DECK 44

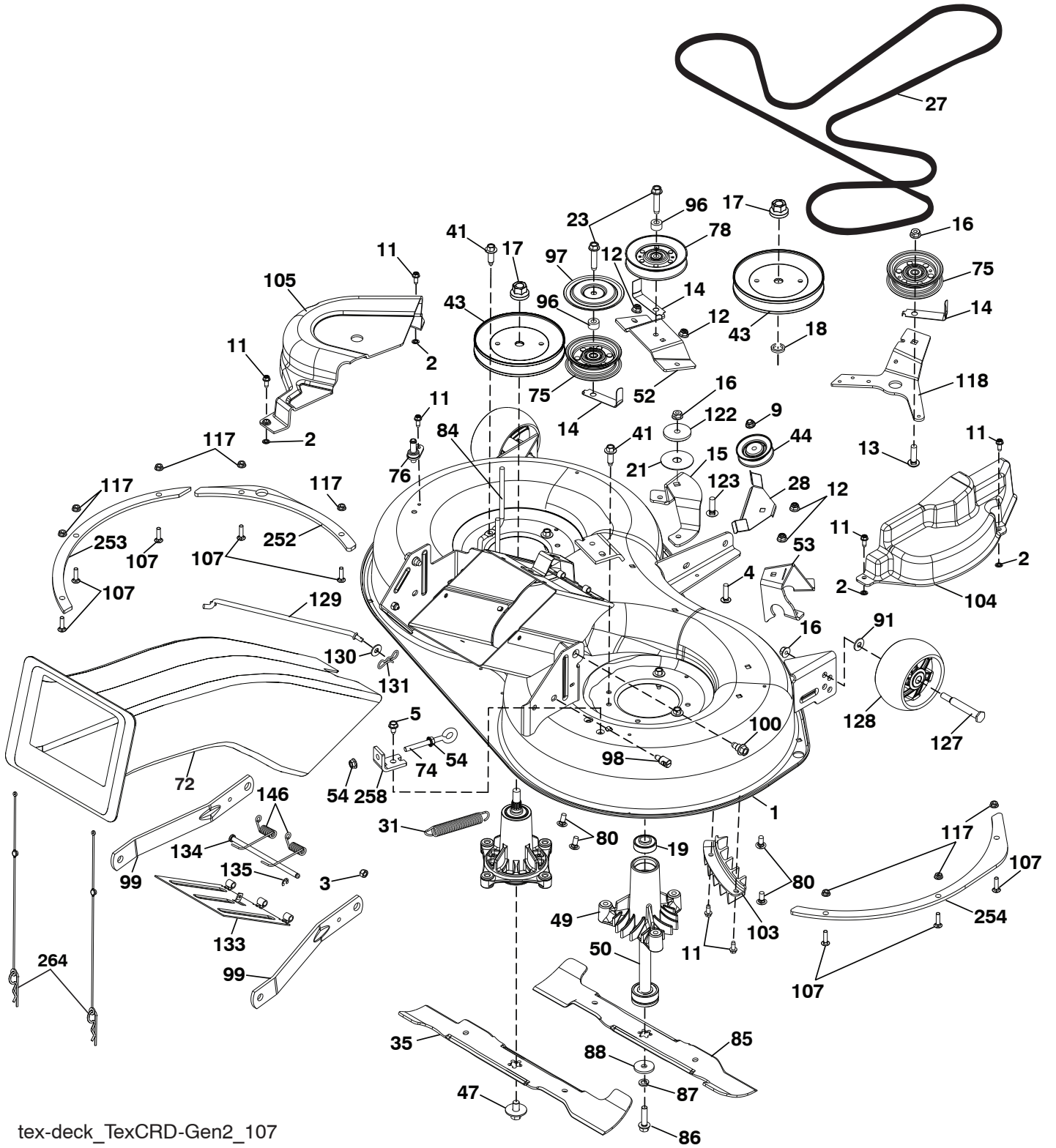

tex-deck\_TexCRD-Gen2\_107

**TRACTOR - - MODEL NO. TC 238 (96051018500), PRODUCT NO. 960 51 01-85  
MOWER DECK 44**

KEY NO.	PART NO.	DESCRIPTION	KEY NO.	PART NO.	DESCRIPTION
1	597 00 08-01	SVC Deck Weldment	91	819 12 14-14	Washer 5/16 Flat Ste Std Zd
2	532 42 30-62	Palnut 1/4	96	532 40 02-71	Spacer
3	873 90 05-00	Nut 5/16-18	97	532 18 20-61	Shield Idler Mower
4	872 11 05-10	Bolt Carr. 5/16-18 x 1-1/4 Gr.5	98	532 19 51-61	Stud Fastener
5	817 00 05-10	Bolt 5/16-18	99	532 19 51-86	Arm Suspension
9	585 69 13-01	Nut Hex Flg Nylock	100	532 19 65-39	Bolt Shoulder
11	532 13 77-29	Screw 1/4-20 x 5/8	103	532 43 69-92	Guard Front Vent
12	539 11 28-99	Nut 5/16-18 Hex Flange Nyloc	104	592 84 81-01	Mandrel Cover RH
13	872 11 06-12	Bolt 3/8-16 x 1-1/2	105	532 43 87-44	Mandrel Cover LH
14	532 15 60-85	Keeper Belt Idler	107	592 80 78-01	Bolt Carriage 1/4-20 x 3/4
15	592 85 47-02	Crd Idler Arm Mount Bracket	117	873 90 04-00	Nut 1/4-20
16	873 90 06-00	Nut 3/8-16	118	592 85 48-02	Arm Clutching
17	532 40 02-34	Nut Flange 9/16	122	532 16 57-23	Retainer Spacer
18	532 18 76-90	Washer Spacer Mandrel	123	872 11 06-10	Carriage Bolt 3/8-16 x 1.25
19	585 32 39-01	Bearing Mandrel	127	532 19 34-06	Bolt 3/8-16 x 3-5/8
21	532 17 85-15	Washer Flat Hardened	128	589 52 73-01	Wheel Gauge Rally
23	817 49 06-28	Screw 3/8-16 x 1-3/4	129	532 44 32-37	Rod Anti Sway
27	592 86 91-01	Belt 97 Manual	130	819 13 13-12	Washer 13/32 x 13/16 x 12 Ga.
28	592 85 56-02	Keeper 97 Crd Angled Idler	131	532 19 42-08	Pin Cotter 5/16 Bow Tie Lock
31	587 35 84-01	Spring Extn	133	532 43 55-38	Door, Mulch
35	532 42 79-84	Blade	134	532 43 58-61	Pin, Hinge
41	584 95 39-01	Bolt Hex Wshrhd 3/16-18 x 1.19	135	532 43 79-98	E-Ring 5/16
43	532 19 97-89	Pulley Mandrel	146	532 44 58-96	Spring, Mulch
44	532 19 95-34	Pulley V-Idler Grnd Dr Plated	252	585 30 87-05	Plate Reinforcement LHS
47	584 30 93-01	Screw LH Blade 7/16 x 1	253	585 30 88-05	Plate Reinforcement LHS
49	532 18 72-81	Housing Mandrel	254	585 30 90-05	Plate Reinforcement LHS
50	587 25 65-01	Shaft Asm	258	592 85 60-01	Bracket Adj Tensioner
52	595 09 80-03	Bracket V-Idler Bolt Center	264	589 39 29-01	Retainer Chute Texcrd
53	595 09 81-03	Bracket V-Idler Bolt Angled	--	587 25 33-01	Mandrel Asm
54	539 99 05-85	Nut Whizlock 5/16-18	--	597 00 10-01	Replacement Mower Complete
72	581 45 41-03	Chute Upper			
74	539 11 55-74	Bolt Eye 5/16-18 x 3.5			
75	532 17 34-38	Pulley Idler Flat			
76	532 41 55-98	Washout Port			
78	532 17 39-02	Pulley Idler V-GR Plated 4.25			
80	539 99 03-16	Carriage Bolt 5/16-18 3/4			
84	532 40 01-40	Keeper Belt Mandrel			
85	532 42 79-85	Blade			
86	532 18 17-13	Bolt 3/8-24 x 1.50			
87	539 99 01-18	Washer Lock			
88	532 14 02-96	Washer Hard Blade			

**NOTE:** All component dimensions given in U.S. inches  
1 inch = 25.4 mm

**TRACTOR - - MODEL NO. TC 238 (96051018500), PRODUCT NO. 960 51 01-85**  
**MOWER LIFT 45**

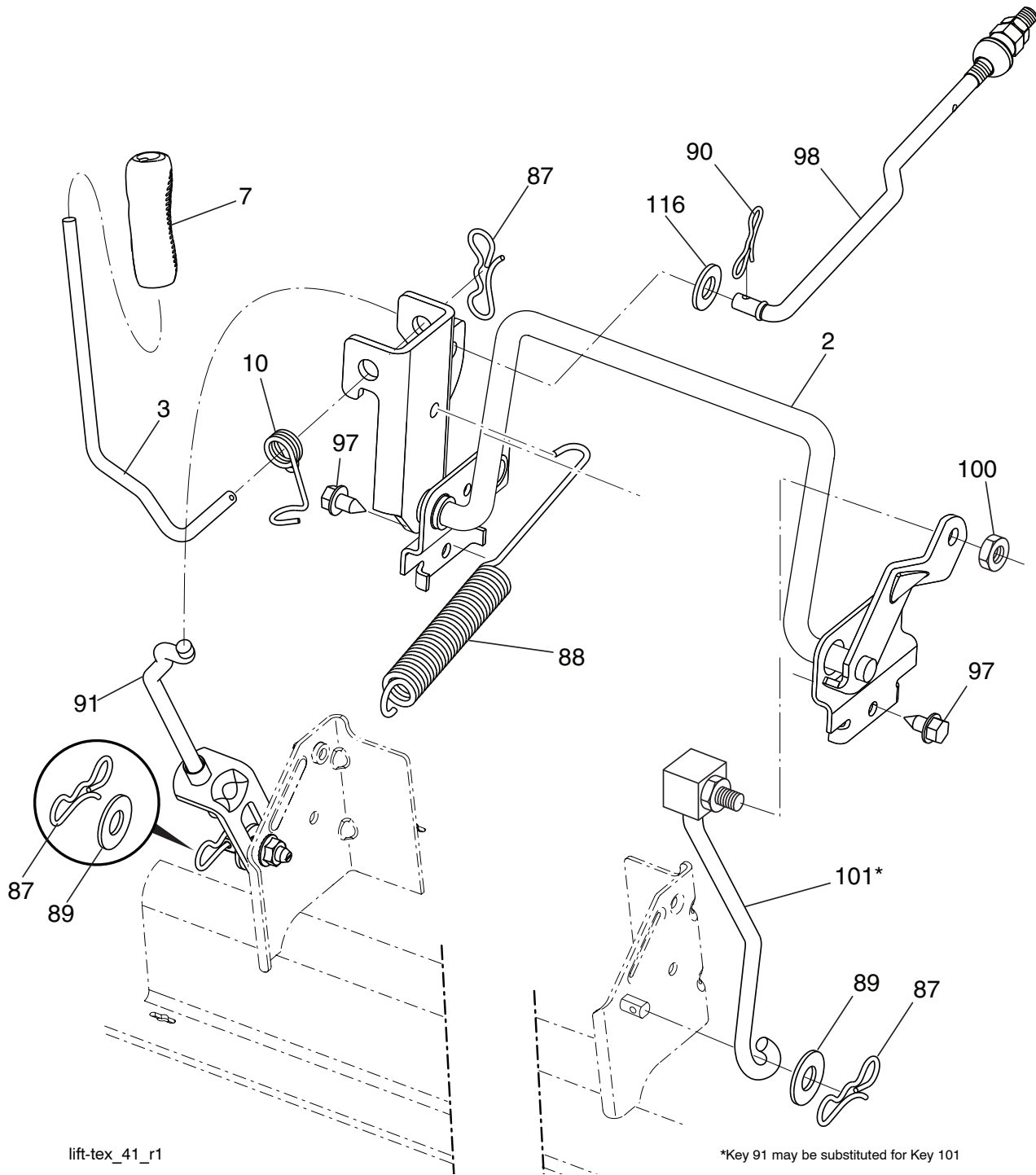

KEY NO.	PART NO.	DESCRIPTION
2	532 43 69-96	Deck Lift Weldment
3	532 19 52-31	Lever Asm., Lift RH
7	580 96 23-01	Grip, Lever
10	532 19 63-14	Spring Torsion
87	532 19 42-09	Pin Cotter 7/16 Bow Tie Lock
88	532 44 54-96	Spring Lift Assist
89	819 19 19-12	Washer Clear Zinc
90	532 19 42-08	Pin Cotter 5/16 Bow Tie Lock
91	532 19 51-81	Link Lift Susp Mower Rear

KEY NO.	PART NO.	DESCRIPTION
97	817 49 06-08	Screw 3/8-16 x 1/2
98	532 19 52-70	Link Lift Susp. Front Mower
100	873 93 06-00	Nut Centerlock 3/8-16 unc
101	532 40 70-03	Link Asm. Lift Fixed
116	819 15 15-16	Washer 15/32 x 15/16 x 16 Ga.

**NOTE:** All component dimensions given in U.S. inches  
 1 inch = 25.4 mm



**TRACTOR - - MODEL NO. TC 238 (96051018500), PRODUCT NO. 960 51 01-85  
SEAT ASSEMBLY 42**

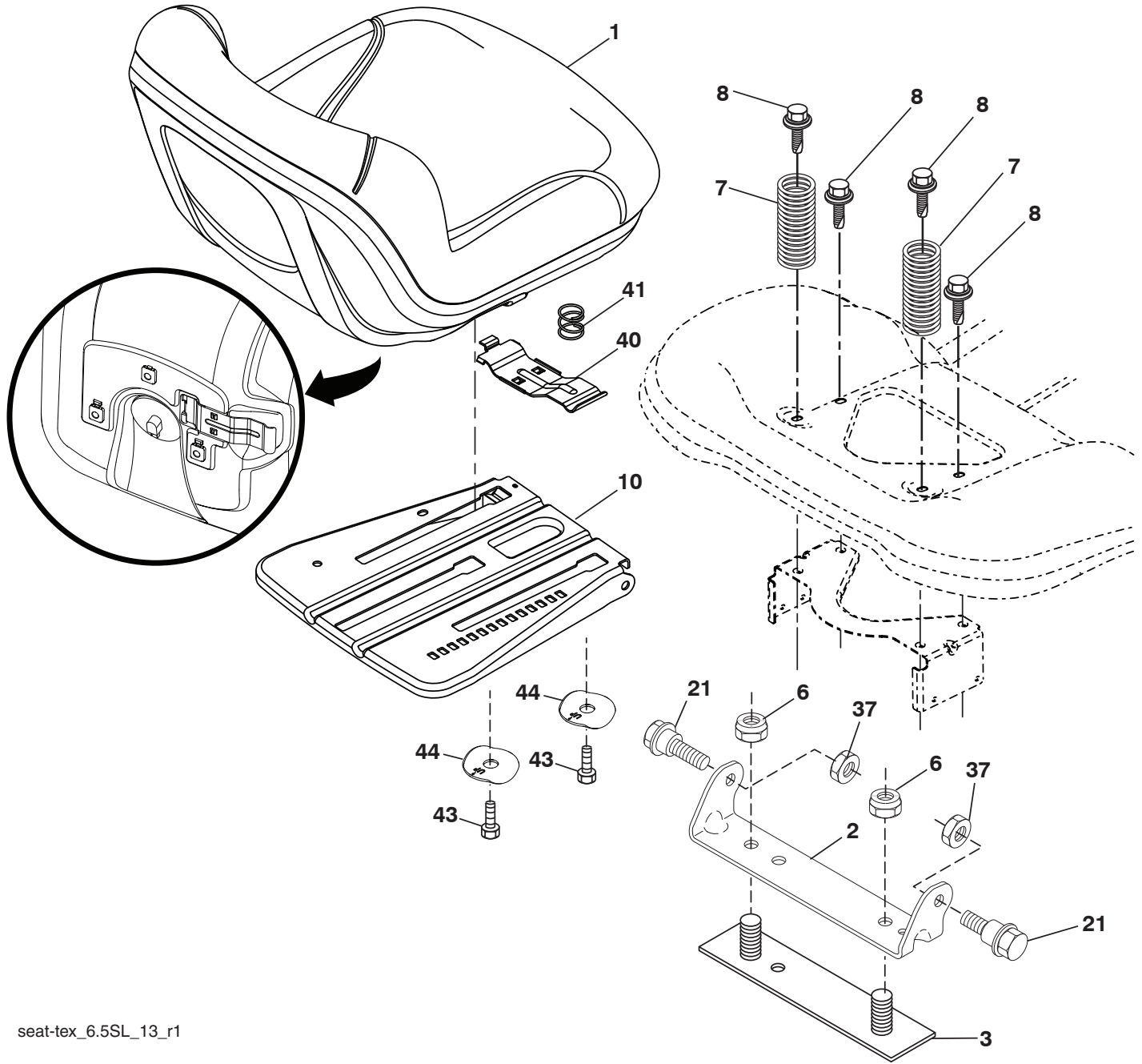

seat-tex\_6.5SL\_13\_r1

KEY NO.	PART NO.	DESCRIPTION
1	532 43 98-22	Seat
2	532 18 01-66	Bracket Pivot Fender
3	532 14 06-75	Strap, Asm Fender
6	873 80 06-00	Nut, Lock W/Ins. 3/8-16 unc
7	589 48 35-01	Spring, Seat Cprsn
8	532 17 18-77	Bolt 5/16-18 unc x 3/4 w/Sems
10	596 65 74-02	Pan, Seat
21	587 90 78-01	Bolt, Shoulder 5/16-18 x 5/8
37	873 80 05-00	Nut, Lock 5/16-18 unc

KEY NO.	PART NO.	DESCRIPTION
40	532 19 76-61	Handle Slide Seat
41	532 19 82-00	Spring Latch Seat
43	874 76 06-12	Bolt Fin Hex 3/8-16 unc x 3/4
44	501 05 18-01	Washer Winged 3/8 ID 1.5 OD

**NOTE:** All component dimensions given in U.S. inches  
1 inch = 25.4 mm

TRACTOR - - MODEL NO. TC 238 (96051018500), PRODUCT NO. 960 51 01-85  
BAGGER **46**

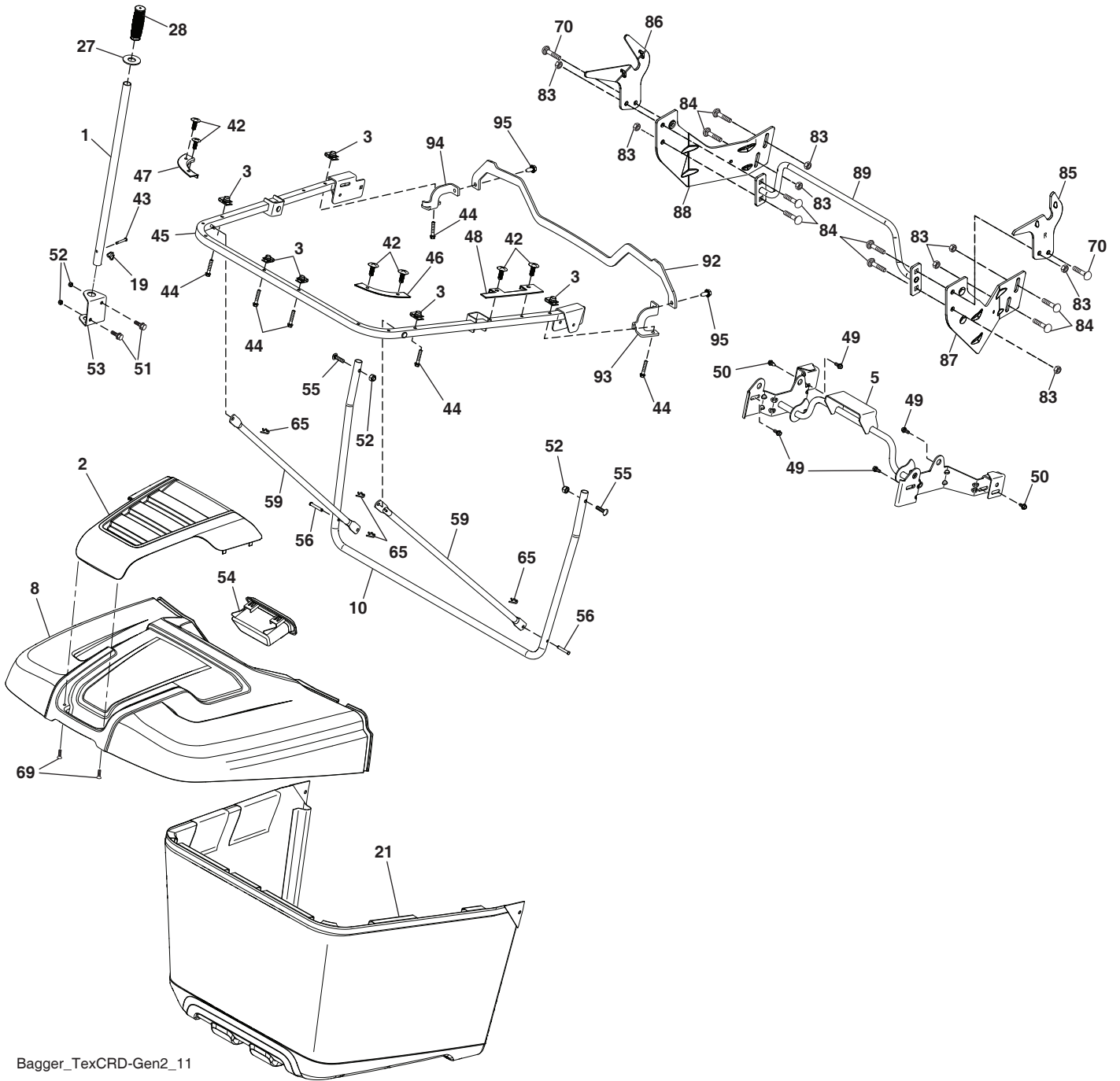

Bagger\_TexCRD-Gen2\_11

**TRACTOR - - MODEL NO. TC 238 (96051018500), PRODUCT NO. 960 51 01-85  
BAGGER 46**

<b>KEY NO.</b>	<b>PART NO.</b>	<b>DESCRIPTION</b>
1	532 42 86-10	Tube Handle Bagger
2	532 44 75-72	Applique
3	532 17 48-14	Clip
5	532 44 37-62	Upper Pivot Tube
8	532 44 75-75	Bagger Top
10	532 44 37-55	Frame Front
19	532 19 42-08	Cotter Pin 5/16 Bow Tie
21	581 33 71-03	Bag Asm
27	532 44 55-29	Grommet Rubber
28	532 16 57-87	Grip Handle
42	532 44 04-28	Clip
43	532 12 68-75	Clevis Pin
44	532 19 96-87	Bolt 1/4-20
45	532 44 37-54	Upper Frame
46	532 44 55-41	Bag Corner Close Out RH
47	532 44 40-79	Bag Corner Close Out LH
48	532 44 40-80	Top Bagger Side Close Out
49	532 17 18-73	Bolt Shoulder 5/16-18
50	532 17 18-77	Bolt 5/16-18 x 3/4 W/Sems
51	872 11 05-06	Bolt 5/16 x 18 x 3/4
52	873 80 05-00	Nut Lock Hex W/Ins 5/16-18 unc
53	532 44 41-95	Bracket Dump Handle
54	532 44 72-18	Bagger Top Front Handle
55	539 10 29-33	Bolt 5/16-18 x 1-1/2 Gr. 5 ZD
56	532 42 03-06	Pin Clevis .183 x 1.26
59	532 44 47-63	Bagger Sprd Tube
65	532 00 44-97	Clip Retainer
69	532 42 18-01	Screw #8 Flat Head Drill
70	817 00 06-12	Screw 3/8-16 x 3/4
83	873 80 06-00	Nut Lock Hex w/Ins. 3/8-16 unc
84	872 11 06-08	Bolt 3/8-16 x 1 Gr. 5
85	581 31 44-02	Bracket RH Pivot
86	581 31 43-02	Bracket LH Pivot
87	581 31 48-02	Bracket RH
88	581 31 47-02	Bracket LH
89	581 31 51-04	Weldment Offset Strut
92	586 05 23-02	Bracket Top Support
93	586 05 24-02	Bracket Support RH
94	586 05 25-02	Bracket Support LH
95	817 00 05-12	Screw 5/16-18 x 3/4

**NOTE:** All component dimensions given in U.S. inches  
1 inch = 25.4 mm

