

# ILLUSTRATED PARTS LIST

**MODEL NO. 96051002105**

**CUSTOMER CATALOG NO. LT2317 CMA**

**PRODUCT NO. 960 51 00-21**

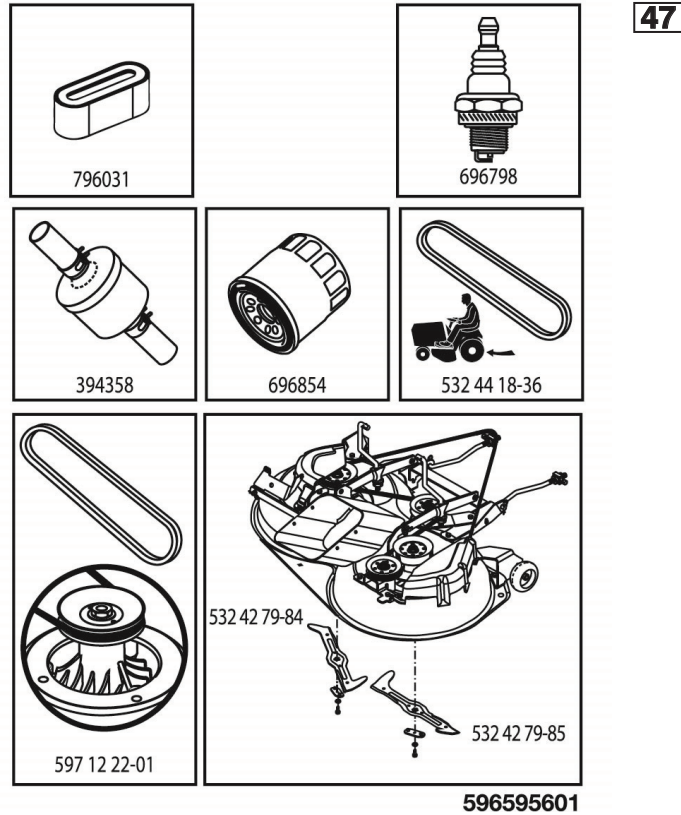

**TRACTOR - MODEL NO. LT2317 CMA (96051002105), PROD. NO. 960 51 00-21  
DECALS 27**

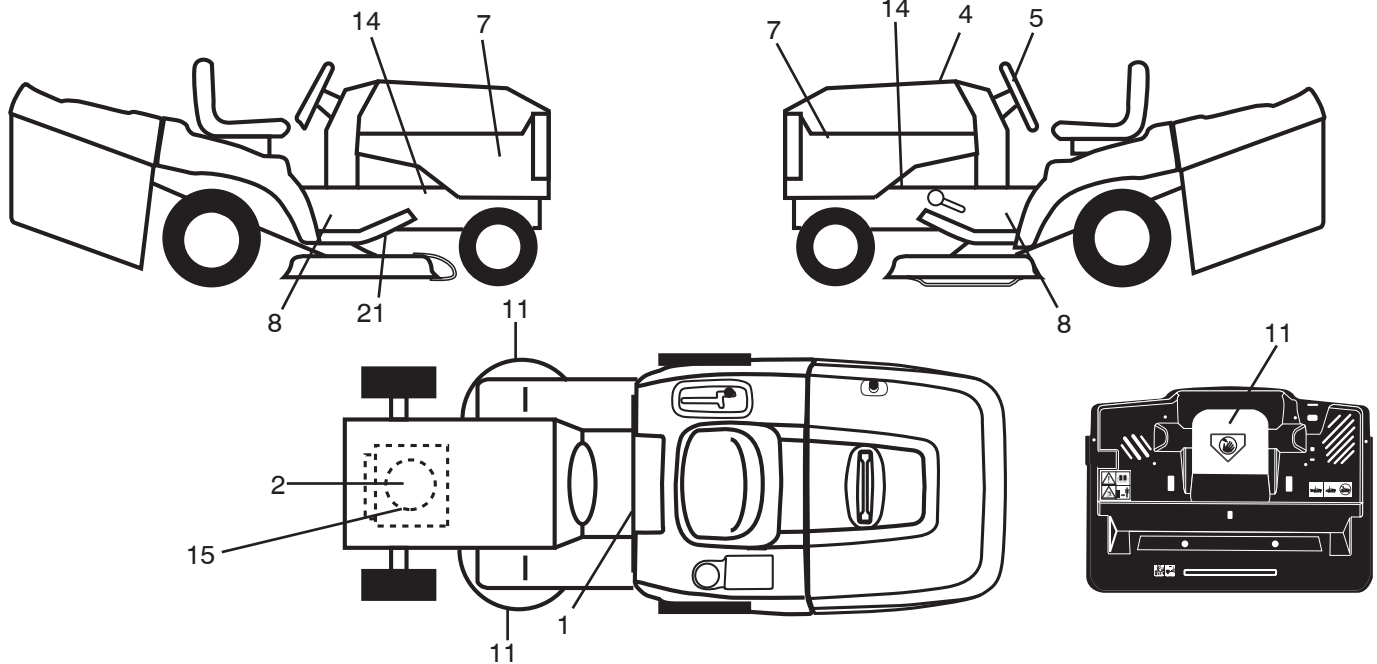

KEY NO.	PART NO.	DESCRIPTION
1	581 57 83-01	Decal Warning Sym
2	581 57 97-01	Decal Warning Eng. Sym.
4	596 59 56-01	Decal Replacement
5	590 75 56-01	Decal Wheel Steering
7	582 33 82-01	Decal Side Panel
8	581 57 98-01	Decal Warning Service Fire
11	581 57 91-01	Decal Cutfinger
14	581 57 96-01	Decal Chassis Hot Muffler
15	532 43 74-82	Decal Engine HP

KEY NO.	PART NO.	DESCRIPTION
21	592 98 02-01	Decal Hex Belt Sch
--	532 44 27-44	Decal, Battery Door
--	588 82 14-01	Decal, Inst. Mulch Plug
--	532 42 59-28	Pad Footrest RH
--	532 42 59-76	Pad Footrest LH
--	114 07 55-20	Manual Operator's (Euro)
--	114 07 56-10	Manual Operator's (Scand)
--	114 07 57-50	Manual Operator's (Ebloc)
--	114 07 58-40	Manual Operator's (Baltic)

**WHEELS & TIRES**

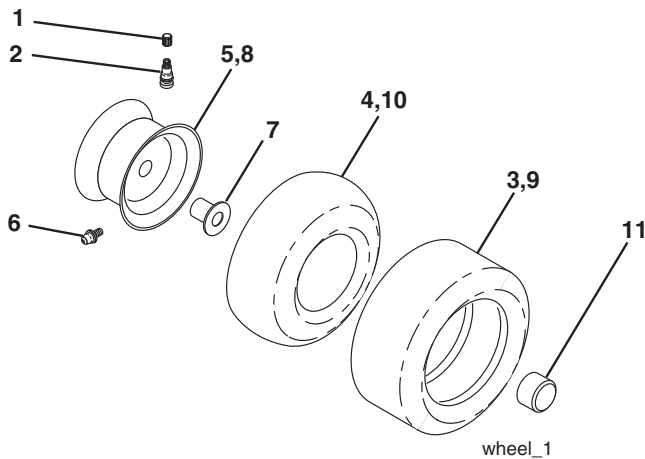

KEY NO.	PART NO.	DESCRIPTION
1	532 05 91-92	Cap Valve Tire
2	532 06 51-39	Stem Valve
3	532 10 62-22	Tire Front 15 x 6-6
4	532 05 99-04	Tube Inner Front #35060
5	532 13 83-36	Rim Asm 6" Front Silver Service
6	532 12 49-57	Fitting Grease
7	532 12 49-59	Bearing Flange
8	532 13 83-37	Rim Asm 8" Rear Silver Service
9	532 42 05-31	Tire Rear 18 x 9.5-8
10	532 00 71-52	Tube Rear 9.5 x 8 Service
11	532 17 50-39	Cap Axle Blk 1.50 x 1.00
--	532 14 43-34	Sealant, Tire (10 oz. Tube)

**NOTE:** All component dimensions given in U.S. inches  
1 inch = 25.4 mm

# TRACTOR - MODEL NO. LT2317 CMA (96051002105), PROD. NO. 960 51 00-21

## SCHEMATIC **38**

SCH17

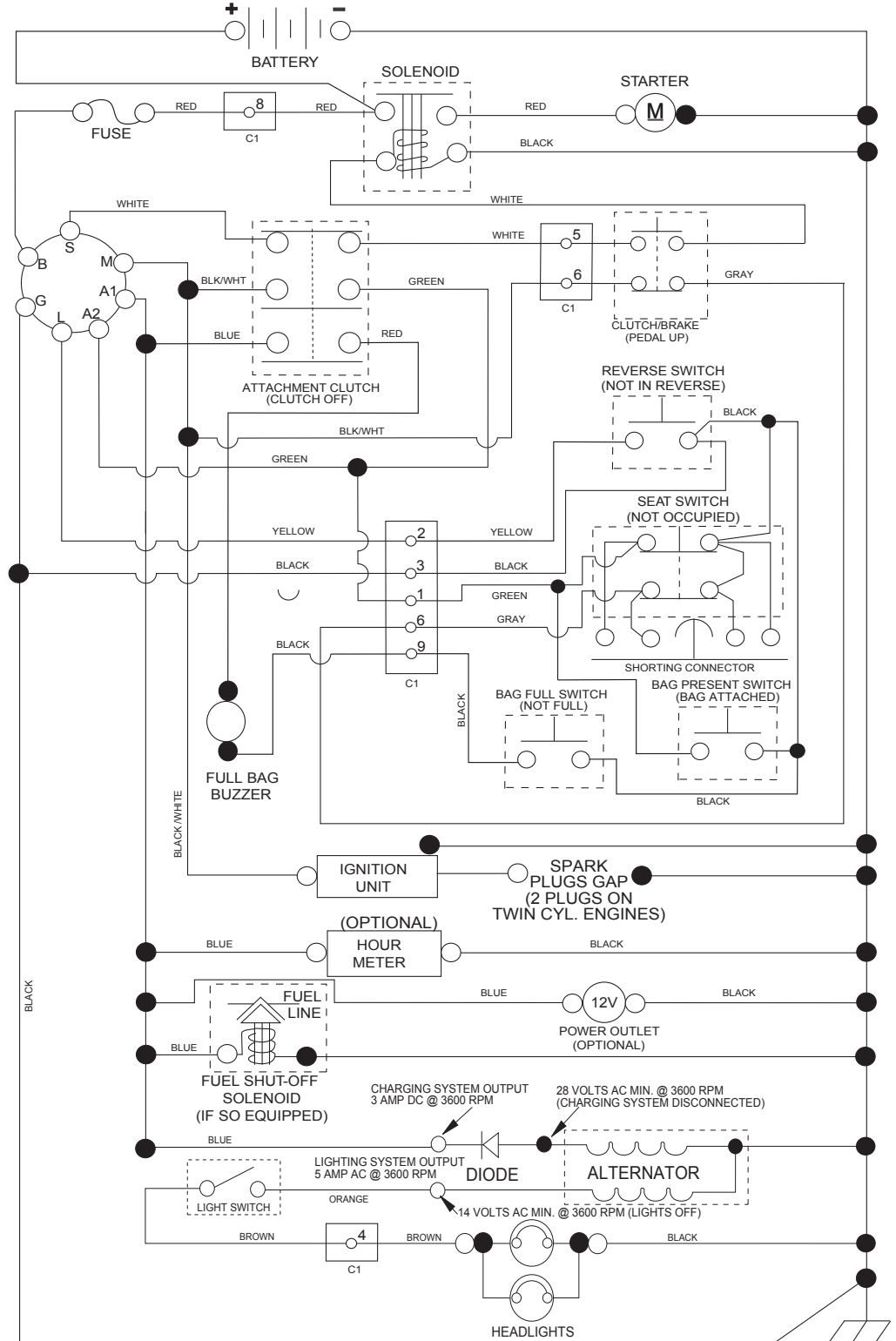

**NOTE**  
YOUR TRACTOR IS EQUIPPED WITH A SPECIAL ALTERNATOR SYSTEM. THE LIGHTS ARE NOT CONNECTED TO THE BATTERY, BUT HAVE THEIR OWN ELECTRICAL SOURCE. BECAUSE OF THIS, THE BRIGHTNESS OF THE LIGHTS WILL CHANGE WITH ENGINE SPEED. AT IDLE THE LIGHTS WILL DIM. AS THE ENGINE SPEED IS INCREASED, THE LIGHTS WILL BECOME THEIR BRIGHTEST.

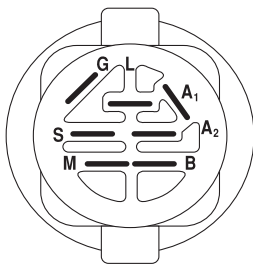

IGNITION SWITCH

POSITION	CIRCUIT "MAKE"
OFF	M+G+A1
RUN/OVERRIDE	B+A1
RUN	B+A1 L+A2
START	B + S + A1



CHASSIS HARNESS CONNECTOR (C1) (MATING SIDE)

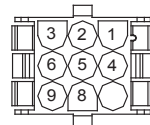

DASH HARNESS CONNECTOR (C1) (MATING SIDE)

WIRING INSULATED CLIPS  
NOTE: IF WIRING INSULATED CLIPS WERE REMOVED FOR SERVICING OF UNIT, THEY SHOULD BE RE-INSTALLED TO PROPERLY SECURE YOUR WIRING.

● NON-REMOVABLE CONNECTIONS

○ REMOVABLE CONNECTIONS

**TRACTOR - MODEL NO. LT2317 CMA (96051002105), PROD. NO. 960 51 00-21**  
**ELECTRICAL 32**

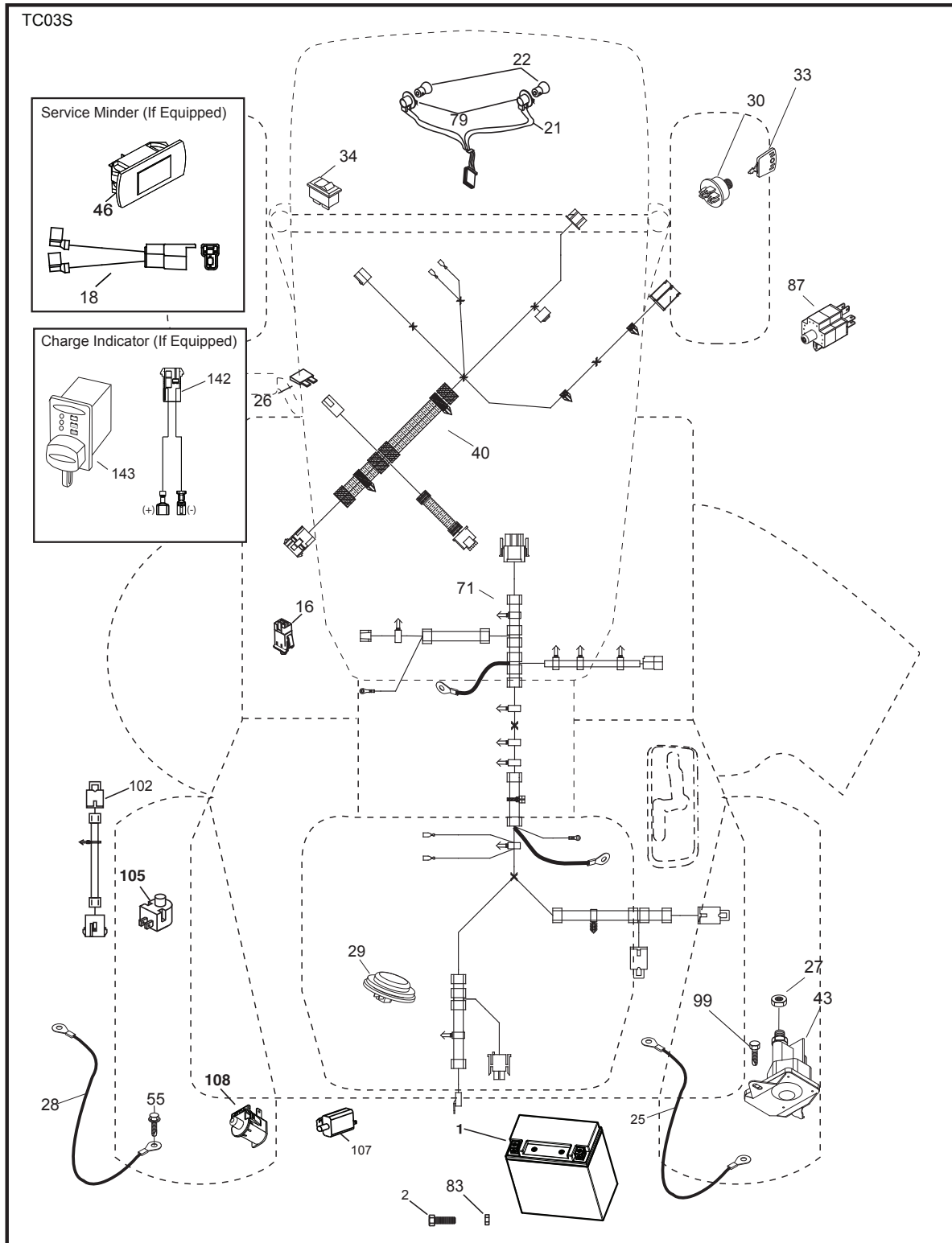

**TRACTOR - MODEL NO. LT2317 CMA (96051002105), PROD. NO. 960 51 00-21  
ELECTRICAL 32**

KEY NO.	PART NO.	DESCRIPTION
1	532 43 71-57	Battery
2	532 44 09-23	Screw Hex Head Cap M6 x 1.12 mm
16	532 17 61-38	Switch Interlock Push-In
21	532 40 02-52	Harness Socket Light w/4152J
22	532 00 41-52	Bulb Light
25	581 48 98-01	Cable Starter
26	532 17 51-58	Fuse
27	873 51 04-00	Nut Keps Hex 1/4-20 unc
28	581 48 98-02	Cable, Ground
29	532 40 15-45	Switch, Seat
30	532 19 33-50	Switch, Ign.
33	532 41 19-35	Key/Chain
34	532 11 07-12	Switch Light/Reset
40	532 42 10-02	Harness Ign. Dash
43	582 04 28-01	Solenoid
55	817 06 05-12	Screw Thdrol. 5/16-18 x 3/4 TYTT
71	532 44 08-20	Harness Ign. Chassis
79	532 17 52-42	Socket Asm. Bulb Twistlock
83	532 43 67-74	Nut Square M6 x 1.8.5 x 11 mm
87	532 42 10-60	Switch Interlock Clutch Cable
99	817 00 05-12	Bolt Hex Wsh Hd 5/16-18 x 3/4
102	532 44 12-62	Harness Jumper
105	532 40 75-68	Switch Reversing
107	532 18 03-79	Switch Full Bagger Indicator
108	532 42 10-62	Switch Snapmount

**NOTE:** All component dimensions given in U.S. inches  
1 inch = 25.4 mm

**TRACTOR - MODEL NO. LT2317 CMA (96051002105), PROD. NO. 96051 00-21**  
**CHASSIS AND ENCLOSURES 39**

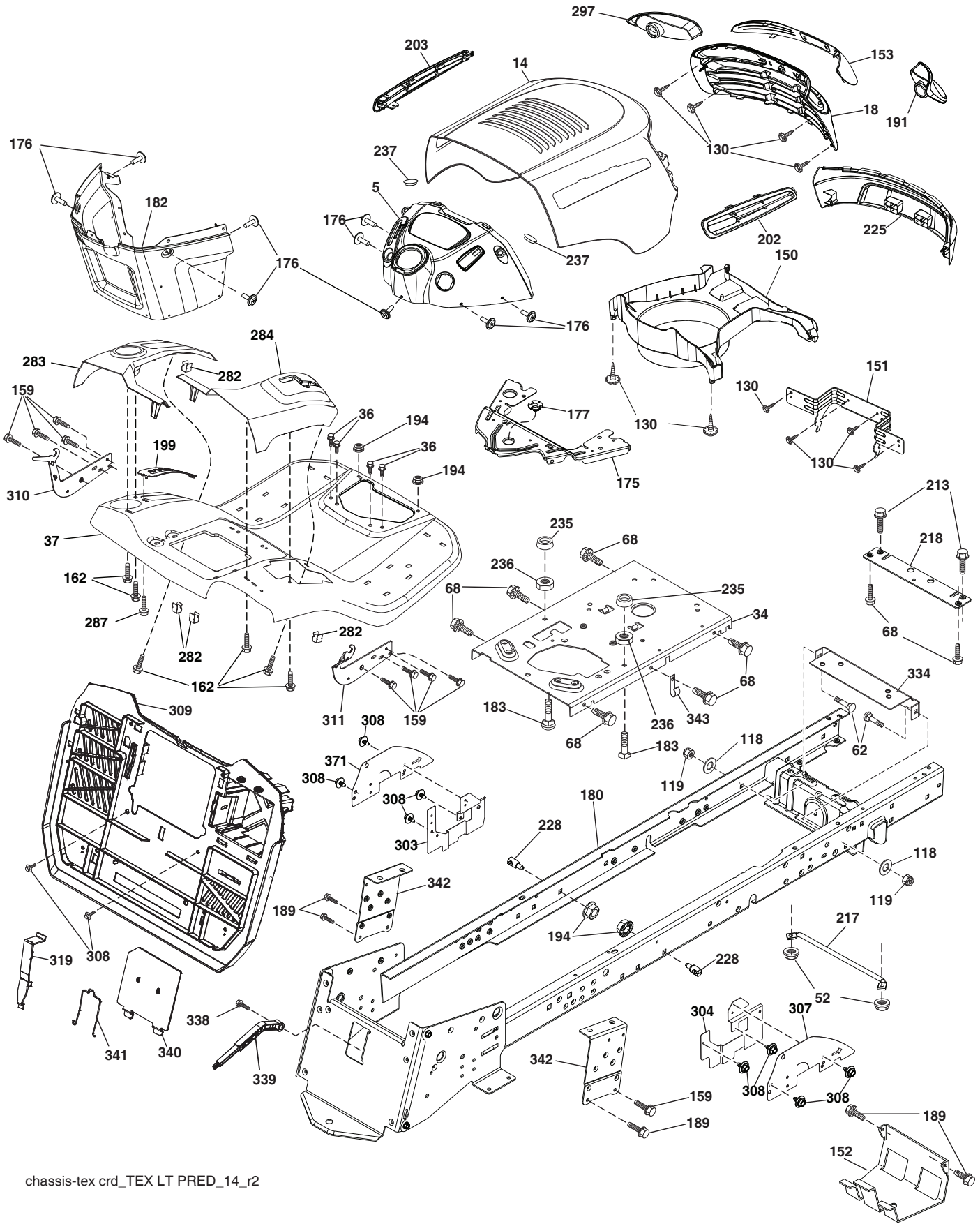

chassis-tex crd\_TEX LT PRED\_14\_r2

**TRACTOR - MODEL NO. LT2317 CMA (96051002105), PROD. NO. 960 51 00-21  
CHASSIS AND ENCLOSURES 39**

KEY NO.	PART NO.	DESCRIPTION	KEY NO.	PART NO.	DESCRIPTION
5	532 40 95-97	Dash	217	532 40 91-67	Rod Pivot Hood
14	532 44 12-87	Hood	218	532 19 63-95	X-Piece Hood Stop
18	532 42 65-11	Grille	225	589 03 29-01	Bumper Grille
34	580 91 09-01	Plate Engine	228	532 19 51-61	Stud Fastener
36	817 06 05-12	Screw 5/16-18 x 3/4	235	532 40 61-29	Spacer Fender
37	532 44 22-31	Fender	236	873 93 05 00	Nut Center Lock 5/16-18 unc
52	873 68 05-00	Nut Crownlock 5/16-18	237	532 40 37-04	Plug Mount Cargo
62	872 11 06-08	Bolt 3/8-16 x 1 Gr. 5	282	532 41 41-10	Clip Retainer
68	539 99 08-58	Screw Thdrol. 5/16-18 x 1/2	283	532 44 03-61	Console Deck Lift
118	819 13 13-16	Washer 13/32 x 13/16 x 16 Ga.	284	532 44 12-92	Console Shift RH
119	873 68 06-00	Nut Crownlock CRD	287	817 60 04-06	Screw Hex Washhead. 1/4-20 x 3/8
130	532 41 63-58	Screw #10 x .750 BOS Thread	297	532 40 18-27	Insert Reflective LH
150	532 40 02-67	Air Duct	303	589 00 76-02	Shield LH
151	532 18 75-68	Bracket Pivot	304	589 41 27-02	Shield RH
152	532 19 95-35	Shield Browning	307	587 52 74-01	Shield Upper RH
153	532 44 42-64	Lens	308	532 17 18-77	Bolt 5/16-18 unc x 3/4
159	817 00 06-12	Screw 3/8-16 x 3/4	309	501 18 83-01	Backplate
162	532 14 24-32	Screw Hex Wsh. Hi-Lo 1/4 x 1/2 unc	310	532 44 66-36	Bracket Hangbar Bag LH
175	532 19 94-72	Crossmember	311	532 44 66-37	Bracket Hangbar Bag RH
176	532 40 07-76	Screw 10-24 x 5/8	319	532 17 46-62	Bracket Actuator Bagger
177	532 19 52-28	Bushing Steering	334	532 44 25-37	Bracket Engine
180	581 18 71-01	Chassis	338	532 43 66-40	Bolt Shoulder
182	532 40 71-76	Dash Lower	339	532 43 66-41	Lever Bagger Full
183	874 52 05-20	Bolt 5/16-18 x 1-1/4	340	532 44 09-31	Door Battery Tray
189	817 00 05-12	Screw 5/16-18 x 3/4	341	582 06 08-01	Latch Batter Tray
191	532 41 65-02	Insert Reflective RH	342	582 82 68-02	Support Fender
194	873 90 05-00	Nut Lock Hex Flange 5/16-18	343	532 44 07-49	Clip
199	532 41 87-39	Plate Deck Lift	371	587 49 45-01	Shield Upper
202	591 16 53-01	Vent Side Hood RH			
203	591 16 53-02	Vent Side Hood LH			
213	539 97 69-34	Bolt Hex HD 5/16-18 x 3/4 Gr. 5			

**NOTE:** All component dimensions given in U.S. inches  
1 inch = 25.4 mm





**TRACTOR - MODEL NO. LT2317 CMA (96051002105), PROD. NO. 960 51 00-21  
DRIVE **40****

KEY NO.	PART NO.	DESCRIPTION	KEY NO.	PART NO.	DESCRIPTION
1	---	Transaxle, Tufftorq K46DC (448355) (Order parts from transaxle manufacturer.)	188	582 21 70-01	Link Clutch Ground Drive, Long
2	532 12 35-83	Key Square	189	532 43 36-11	Bellcrank Ground Drive
6	532 12 40-28	Bushing Snap	195	580 45 69-01	Bracket Rod Brake
15	819 13 13-16	Washer 13/32 x 13/16 x 16 Ga.	203	819 11 11-16	Washer 11/32 x 11/16 x 16
17	532 43 62-27	Spring, Brake	205	532 12 17-48	Washer 25/32 x 1-5/8 x 16 Ga.
22	532 44 32-46	Rod Shift	221	532 40 31-87	Retainer Spring Clip
23	532 13 05-64	Knob	226	532 40 15-64	Bracket Mount Torque
29	532 43 58-81	Rod, Brake	227	817 49 05-12	Screw Thdrol 5/16-18 x 3/4
33	812 00 00-01	Ring E	263	817 00 06-12	Screw Thdr 3/8-16 x 3/4
35	532 40 10-31	Rod, Brake, Park	268	532 18 24-02	Guard Muffler
37	532 18 89-67	Washer Hardened	275	819 13 16-14	Washer 13/32 x 1 x 14 Ga.
38	532 16 96-13	Nyliner Snap In	279	532 44 42-83	Link Shift
42	532 12 48-72	Cover, Foot Pedal	280	819 11 10-12	Washer 11/32 x 5/8
49	872 11 06-14	Bolt 3/8-16 x 1 3/4	309	532 16 55-81	Plate Fstnr. Cross
50	532 19 43-27	Pulley Idler Flat	311	532 16 98-45	Washer Nylon
51	873 90 06-00	Lock Nut 3/8-16	312	532 16 56-14	Hub Tapered
52	532 19 43-26	Idler V-Groove	313	874 78 04-16	Bolt Hex Fin 1/4-20 unc x 1 Gr. 5
56	532 44 18-36	V-Belt, Drive	314	532 44 47-13	Keeper Belt
61	532 43 77-88	Pulley Transaxle	315	817 58 05-20	Screw Thdrol 5/16-18 x 1.25
64	532 19 62-00	Shaft Asm. Pedal Brake Control	319	532 43 67-94	Spacer Transaxle
73	874 49 05-60	Bolt Hex Flanged 5/16-18 x 3.75	320	532 18 76-90	Washer Spacer
90	532 44 36-05	Keeper Belt Clutching	328	532 43 57-58	Shaft Shift Front
99	532 44 39-47	Rod Spring Bypass	330	532 16 95-93	Washer Nyliner
103	873 35 05-00	Nut Hex Jam 5/16-18 unc	331	532 44 36-06	Hub Shift
116	873 90 05-00	Nut Lock Hex Flange 5/16-18	333	532 17 08-68	Washer Spring Wave
125	817 00 05-12	Screw 5/16-18 x 3/4	335	532 19 95-34	Idler V Pulley Grnd. Dr.
126	532 16 60-02	Washer Srrtd. 5/16 ID x 1 x .125	337	532 43 59-37	Bracket Support Shift
140	810 04 04-00	Washer Lock 1/4	339	532 43 68-67	Strap Torque
141	819 09 12-10	Washer 9/32 x 3/4 x 10 Ga.	348	532 44 36-07	Arm Clevis Rod
143	539 99 08-58	Screw Thdrol 5/16-18 x 1/2	350	532 44 50-20	Spring Torsion
159	876 02 04-12	Pin Cotter 1/8 x 3/4	351	532 43 69-98	Bracket Deck Sway
160	532 16 94-84	Retainer Clip	352	532 43 58-19	Bracket Idler
161	532 10 57-09	Spring, Return, Clutch	353	532 43 65-77	Bracket Idler RH
165	532 19 62-12	Nyliner	354	817 49 05-10	Screw 5/16-18 x 5/8
166	532 42 91-64	Nut Push .625	355	532 43 56-69	Bracket
167	532 40 52-57	Latch Brake Parking	356	532 44 64-41	Link Shift Cross Shaft
174	532 19 72-89	Nut Push	360	532 44 47-14	Nut 5/16-24
175	532 44 18-23	Shaft Asm Shift	362	532 43 68-12	Idler Flat
183	532 13 70-57	Spacer Axle	364	532 44 30-32	Bracket Idler
184	532 41 14-84	Handle Parking Brake			
185	872 11 06-22	Bolt 3/8-16 x 2-3/4			
186	532 19 43-21	Spacer Retainer			

**NOTE:** All component dimensions given in U.S. inches  
1 inch = 25.4 mm

TRACTOR - MODEL NO. LT2317 CMA (96051002105), PROD. NO. 960 51 00-21  
ENGINE 24

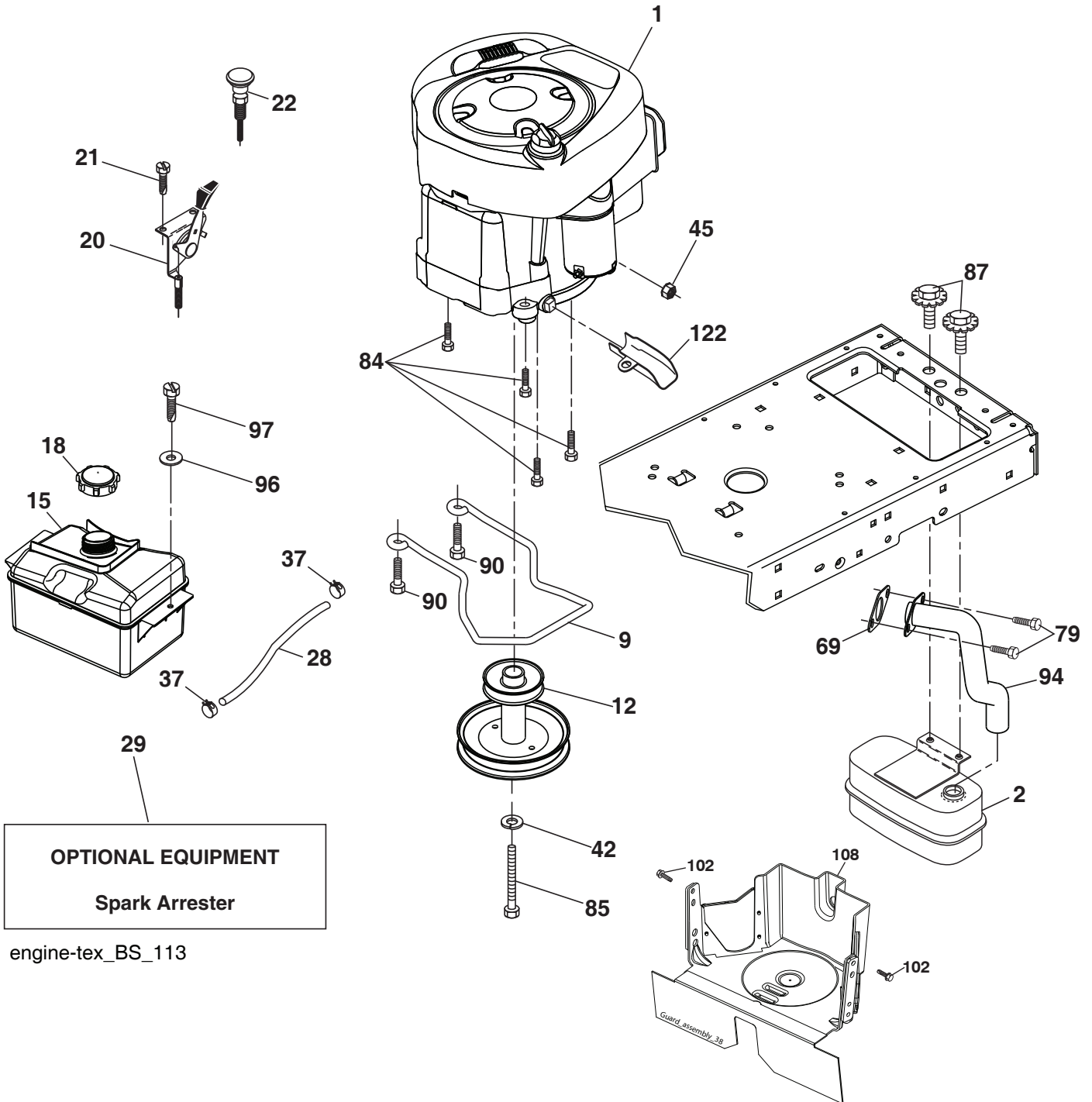

**TRACTOR - MODEL NO. LT2317 CMA (96051002105), PROD. NO. 960 51 00-21  
ENGINE 24**

KEY NO.	PART NO.	DESCRIPTION
1	— — — — —	Engine Briggs Model 31R677-0002-B5 (597359701)(Order parts from engine manufacturer.)
2	532 18 86-55	Muffler
9	501 83 26-02	Keeper Belt Engine
12	586 47 85-01	Pulley Engine
15	581 28 99-01	Tank Fuel 1.5
18	532 43 02-20	Cap Fuel
20	532 18 38-97	Control Throttle
21	532 41 63-58	Screw #10 x 0.750 BOS Thread
22	532 19 49-81	Control Choke
28	532 13 70-40	Fuel Line
29	532 13 71-80	Spark Arrester Kit
37	532 12 34-87	Clamp Hose
42	539 99 02-47	Lock SLW STD 7/16
45	873 51 04-00	Nut Keps Hex 1/4-20 unc
69	532 16 52-91	Gasket
79	532 19 23-34	Screw Socket HD 5/16-18 x .75
84	817 06 06-20	Screw 3/8-16 x 1
85	501 60 65-01	Bolt Hex 7/16-20 x 4 x Gr. 5-1.5 Thr
87	532 17 18-77	Bolt 5/16-18 unc x 3/4 w/Sems.
90	817 00 06-16	Screw 3/8-16 x 1
94	581 88 09-01	Tube Exhaust
96	819 09 14-16	Washer 9/32 x 7/8 x 16 Ga.
97	817 67 04-12	Screw 1/4-20 x 3/4
102	817 06 05-16	Screw 5/16-18 x 1
108	587 17 95-10	Cover Pulley
122	532 42 19-22	Extension Drain Oil

**NOTE:** All component dimensions given in U.S. inches  
1 inch = 25.4 mm

**Engine Power Rating Information**

The gross power rating for individual gas engine models is labeled in accordance with SAE (Society of Automotive Engineers) code J1940 (Small Engine Power & Torque Rating Procedure), and rating performance has been obtained and corrected in accordance with SAE J1995 (Revision 2002-05). Torque values are derived at 3060 RPM; horsepower values are derived at 3600 RPM. Actual gross engine power will be lower and is affected by, among other things, ambient operating conditions and engine-to-engine variability. Given both the wide array of products on which engines are placed and the variety of environmental issues applicable to operating the equipment, the gas engine will not develop the rated gross power when used in a given piece of power equipment (actual “on-site” or net power). This difference is due to a variety of factors including, but not limited to, accessories (air cleaner, exhaust, charging, cooling, carburetor, fuel pump, etc.), application limitations, ambient operating conditions (temperature, humidity, altitude), and engine-to-engine variability. Due to manufacturing and capacity limitations, Briggs & Stratton may substitute an engine of higher rated power for this Series engine.

**TRACTOR - MODEL NO. LT2317 CMA (96051002105), PROD. NO. 960 51 00-21**  
**STEERING ASSEMBLY [41]**

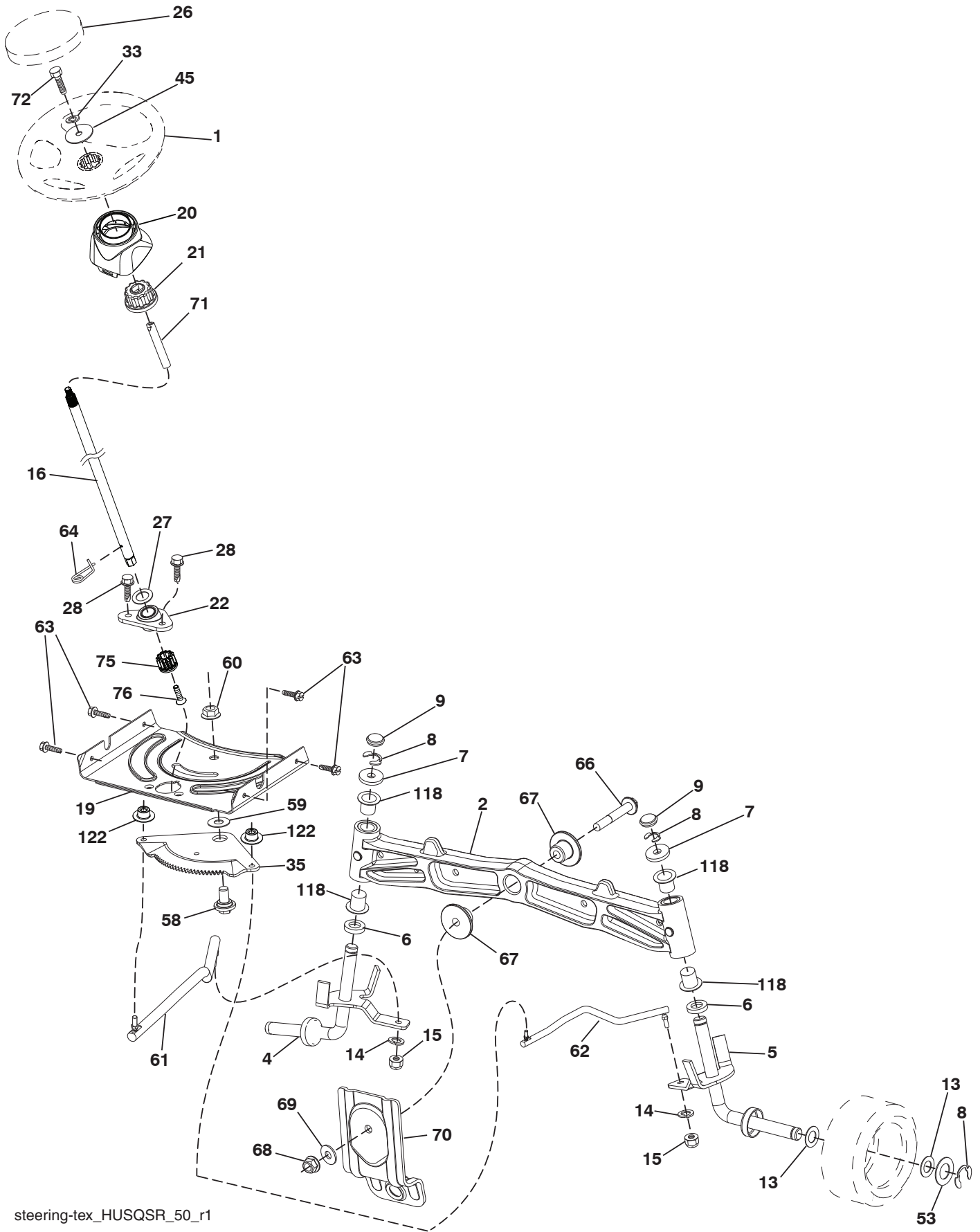

steering-tex\_HUSQSR\_50\_r1

**TRACTOR - MODEL NO. LT2317 CMA (96051002105), PROD. NO. 960 51 00-21  
STEERING ASSEMBLY 41**

<b>KEY NO.</b>	<b>PART NO.</b>	<b>DESCRIPTION</b>
1	532 42 41-46	Wheel, Steering Husq SR
2	532 41 35-91	Axle Asm., Front
4	532 40 30-87	Spindle Asm., LH
5	532 40 30-88	Spindle Asm., RH
6	532 12 49-31	Bearing, Race Thrust Hardened
7	532 12 17-48	Washer 25/32 x 1-5/8 x 16 Ga.
8	812 00 00-29	Ring, Clip #T5304-75
9	532 12 12-32	Cap, Spindle
13	532 12 17-49	Washer 25/32 x 1-1/4 x 16 Ga.
14	539 99 01-18	Washer, SLW ZD 3/8
15	873 54 06-00	Nut, Crown Lock 3/8-24 unf
16	585 86 92-02	Steering Shaft
19	532 19 47-29	Plate Steering
20	532 40 97-63	Boot, Steering
21	532 18 67-37	Adapter, Wheel Steering
22	585 02 98-02	Bearing
26	532 42 41-47	Insert, Wheel Steering Husq SR
27	819 21 16-16	Washer 21 x 32 x 1 x 16 Ga.
28	817 00 06-12	Screw 3/8-16 x 3/4
33	539 99 01-87	Washer Lock 5/16
35	532 19 47-32	Gear, Sector Plate
45	819 11 38-12	Washer 11/32 x 3/8 x 12 Ga.
53	532 18 89-67	Washer Hardened .793 x 1.637 x .060
58	532 19 47-47	Bolt Shoulder Sector Pivot CFM
59	532 19 47-48	Washer Thrust Sector Steering
60	873 97 10-00	Nut Flange Lock 5/8-11
61	532 19 47-40	Draglink, LH
62	532 19 47-41	Draglink, RH
63	817 00 05-12	Screw 5/16-18 x 3/4
64	532 19 98-49	Retainer Clip Spring Steering
66	871 02 07-48	Bolt Hex Fghd. 7/16-14 x 3 Serr.
67	532 19 47-37	Bushing PM Front Axle
68	873 90 07-00	Nut Lock Flange 7/16-14 Gr. 5
69	532 19 91-62	Washer 1.5 x .505 x .118
70	585 33 88-01	Bracket Deck Susp. Front
71	532 19 07-52	Shaft Extension Steering
72	532 42 89-82	Bolt Fin Hx 5/16-18 x 4 w/Patch
75	580 68 37-01	Pinion
76	580 68 36-01	Screw Head Sock
118	532 40 60-13	Bushing Axle
122	532 44 49-62	Cap Gear

**NOTE:** All component dimensions given in U.S. inches  
1 inch = 25.4 mm

TRACTOR - MODEL NO. LT2317 CMA (96051002105), PROD. NO. 960 51 00-21  
MOWER DECK 44

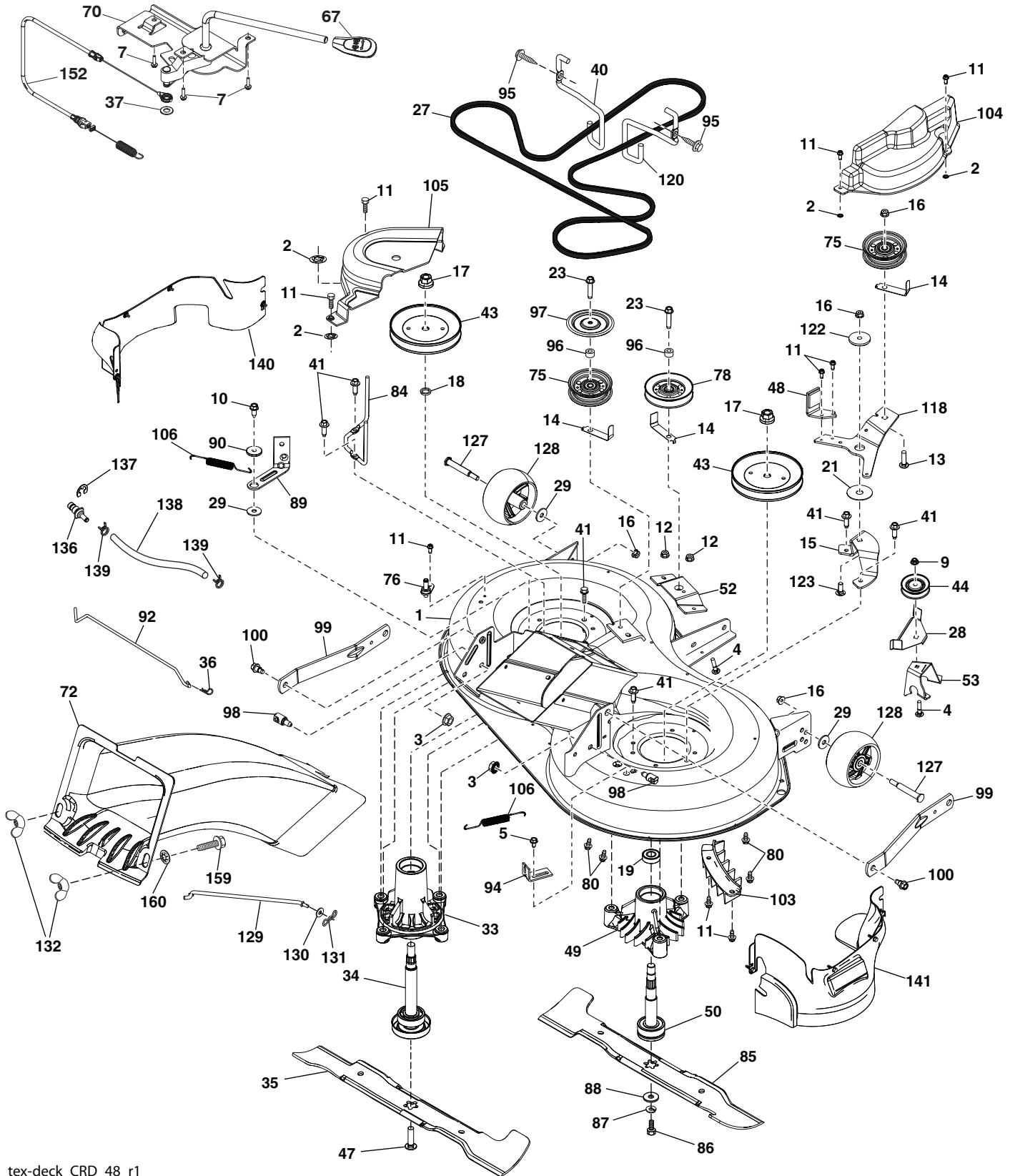

tex-deck\_CRD\_48\_r1

**TRACTOR - MODEL NO. LT2317 CMA (96051002105), PROD. NO. 960 51 00-21**  
**MOWER DECK 44**

KEY NO.	PART NO.	DESCRIPTION	KEY NO.	PART NO.	DESCRIPTION
1	596 58 21-01	Kit SVC Deck Weldment	85	532 42 79-85	Blade Mower RH
2	532 42 30-62	Palnut 1/4	86	532 18 17-13	Bolt 3/8-24 x 1.50 Gr. 8
3	873 90 05-00	Nut Lock Hex Flange 5/16 - 18	87	539 99 01-18	Washer, SLW ZD 3/8
4	872 11 05-10	Bolt Carr 5/16-18 x 1-1/4 Gr. 5	88	532 14 02-96	Washer Hard Blade Mower Vented
5	817 00 05-10	Bolt 5/16-18	89	532 43 81-24	Arm Brake 97 LH
7	532 41 63-58	Screw #10 x 0.750 BOS Thread	90	532 19 90-92	Spacer Retainer
9	585 69 13-01	Nut Hex Flg Nylock	92	592 85 57-01	Rod Brake
10	817 00 06-16	Screw 3/8-16x1 smgml tap	94	532 19 72-50	Bracket Clutch Cable
11	532 13 77-29	Screw Thd Roll 1/4 - 20 X 5/8	95	817 00 06-12	Screw Hexwsh Thdr 3/8-16 x 3/4 Bl.
12	539 11 28-99	Nut 5/16-18 Hex Flange Nyloc	96	532 40 02-71	Spacer
13	872 11 06-12	Bolt Carr Sh 3/8 - 16 X 1 - 1/2 Gr. 5	97	532 18 20-61	Shield Idler Mower
14	532 15 60-85	Keeper Belt Idler	98	532 19 51-61	Stud Fastener
15	592 85 47-02	CRD Idler Arm Mount Bracket	99	532 19 51-86	Arm Suspension
16	873 90 06-00	Nut Lock FIG 3/8 - 16 unc	100	532 19 65-39	Bolt Shoulder
17	532 40 02-34	Nut Flange 9/16	103	532 43 69-92	Guard Front Vent
18	532 18 76-90	Washer Spacer Mandrel	104	592 84 81-01	Mandrel Cover RH
19	585 32 39-01	Bearing Mandrel	105	532 43 87-44	Mandrel Cover LH
21	532 17 85-15	Washer Flat Hardened	106	532 19 32-16	Spring Brake Return
23	817 49 06-28	Screw Thdrol 3/8 - 16 X 1-3/4	118	592 85 48-02	Arm Clutching
27	597 12 22-01	Belt 97 Manual	120	532 19 72-59	Keeper Belt Engine RH
28	592 85 56-02	Keeper 97 CRD Angled Idler	122	532 16 57-23	Retainer Spring
29	819 12 14-14	Washer 5/16 Flat STE STD ZD	123	872 11 06-10	Carriage Bolt 3/8-16 x 1.25
33	532 18 72-81	Housing Mandrel	127	532 19 34-06	Bolt Shoulder 3/8-16 x 3-5/8 Gr. 5
34	587 25 65-01	Shaft Asm	128	589 52 73-01	Wheel Guage
35	532 42 79-84	Blade Mower LH	129	532 40 48-51	Rod Anti-Sway
36	532 12 47-88	Retainer Spring 1"	130	819 13 13-12	Washer 13/32 x 13/16 x 12 Ga.
37	819 13 13-16	Washer 13/32 x 13/16 x 16 Ga.	131	532 19 42-08	Pin Cotter 5/16 Bow Tie Lock
40	532 19 72-58	Keeper Belt Engine LH	132	532 17 88-99	Knob Handle
41	584 95 39-01	Bolt Hex Wsh Hd .313-18 x 1.19	136	532 43 96-39	Washout Port Hookup
43	532 19 74-73	Pulley Mandrel	137	812 00 00-29	Ring Klip
44	532 19 95-34	Pulley V-Idler Grnd Dr Plated	138	532 44 07-43	Hose 3/8 Long 12"
47	584 30 93-01	Screw LH Blade 7-16 x 1	139	532 44 07-42	Hose 3/8 Clamp
48	592 85 49-02	Brake Arm RH	140	501 57 94-01	Guard Asm LH
49	532 12 87-74	Housing Mandrel	141	501 57 93-02	Guard Asm. RH
50	532 16 54-82	Shaft Asm	152	532 44 04-88	Cable Clutch Manual w/Spring
52	595 09 80-03	Bracker V-Idler Bolt Center	159	872 14 06-14	Bolt 3/8-16 x 1-3/4
53	595 09 81-03	Bracket V-Idler Bolt Angled	160	532 16 89-37	Nut Push
67	532 40 30-12	Handle Clutch Cable	--	587 25 33-01	Mandrel Assembly (Includes Housing (key #33), Shaft Assembly (key #34), And Bearing Only (key #19)- Pulley/Nut/Washer And Blade Bolt/Washers Not Included)
70	532 40 12-46	Clutch Asm Manual LT Pred			
72	582 03 56-01	Chute Upper			
75	532 17 34-38	Pulley Idler Flat			
76	532 43 96-40	Washout Port			
78	532 17 39-02	Pulley Idler V-Gr. Plated 4.25	--	596 58 24-01	Replacement Mower Complete
80	539 99 03-16	Carriage Bolt 5/16-18 3/4			
84	589 67 61-02	Keeper Belt Mandrel			

**NOTE:** All component dimensions given in U.S. inches  
1 inch = 25.4 mm

**TRACTOR - MODEL NO. LT2317 CMA (96051002105), PROD. NO. 960 51 00-21**  
**MOWER LIFT 45**

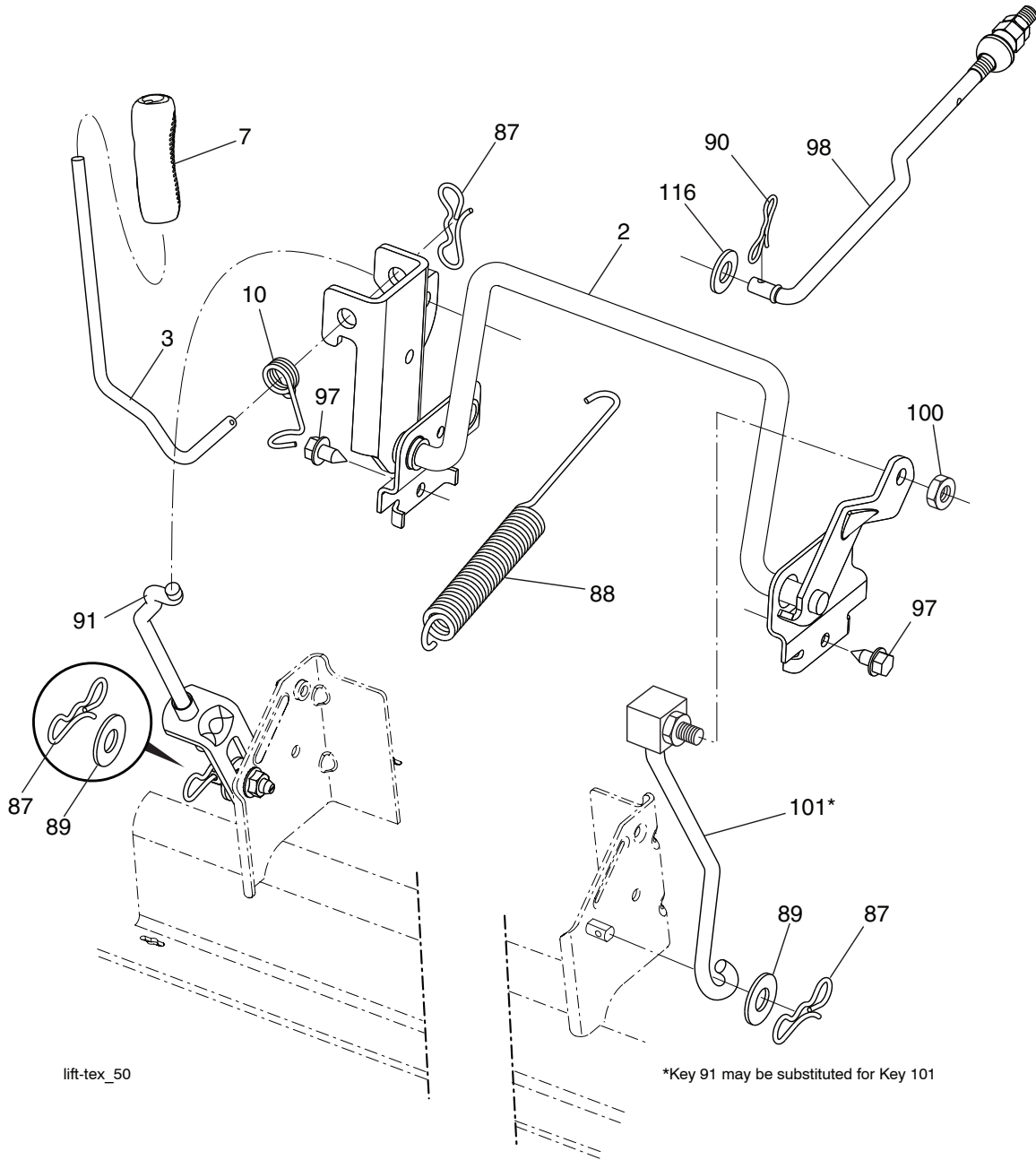

lift-tex\_50

\*Key 91 may be substituted for Key 101

KEY NO.	PART NO.	DESCRIPTION
2	532 43 69-96	Deck Lift Weldment
3	532 19 52-31	Lever Asm., Lift RH
7	580 96 23-01	Grip, Lever
10	532 19 63-14	Spring Torsion
87	532 19 42-09	Pin Cotter 7/16 Bow Tie Lock
88	532 43 69-95	Spring Lift Assist
89	819 19 19-12	Washer Clear Zinc
90	532 19 42-08	Pin Cotter 5/16 Bow Tie Lock

KEY NO.	PART NO.	DESCRIPTION
91	532 19 51-81	Link Lift Susp. Mower Rear
97	817 49 06-08	Screw 3/8-16 x 1/2
98	532 19 52-70	Link Lift Susp. Front Mower
100	873 93 06-00	Nut Centerlock 3/8-16
101	532 40-70-03	Link Asm. Lift FXD
116	819 15 15-16	Washer 15/32 x 15/16 x 16 Ga.

**NOTE:** All component dimensions given in U.S. inches  
 1 inch = 25.4 mm



**TRACTOR - MODEL NO. LT2317 CMA (96051002105), PROD. NO. 960 51 00-21**  
**SEAT ASSEMBLY 42**

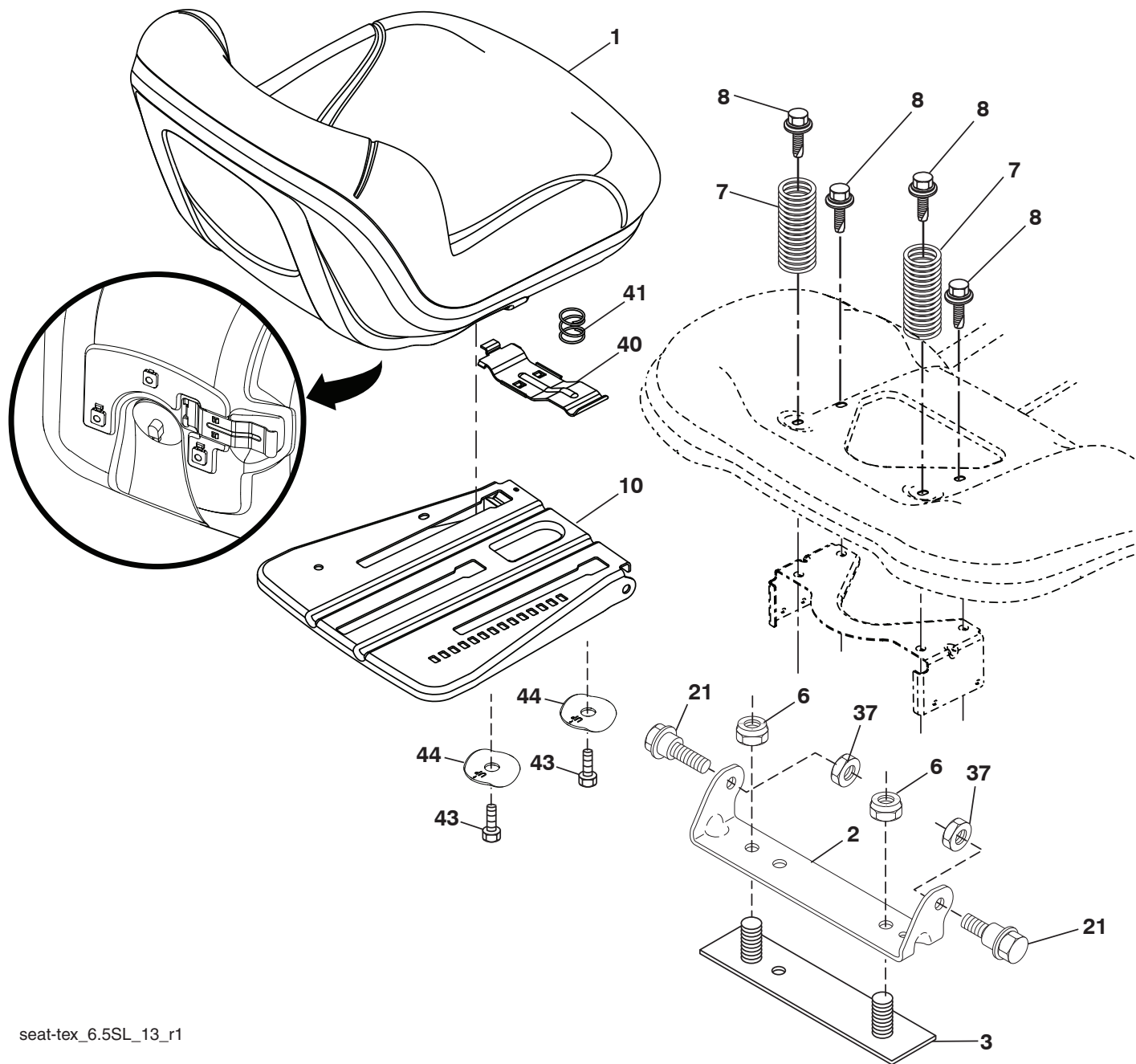

seat-tex\_6.5SL\_13\_r1

KEY NO.	PART NO.	DESCRIPTION
1	532 41 14-05	Seat
2	532 18 01-66	Bracket Pivot Fender
3	532 14 06-75	Strap, Asm. Fender
6	873 80 06-00	Nut, Lock w/Ins. 3/8-16 unc
7	589 48 35-01	Spring, Seat Cprsn.
8	532 17 18-77	Bolt 5/16-18 unc x 3/4 w/Sems.
10	587 23 20-02	Pan, Seat
21	587 90 78-01	Bolt, Shoulder 5/16-18 x 5/8

KEY NO.	PART NO.	DESCRIPTION
37	873 80 05-00	Nut, Lock 5/16-18 unc
40	532 19 76-61	Handle
41	532 19 82-00	Spring
43	874 76 06-12	Bolt 3/8-16 unc x 3/4
44	501 05 18-01	Washer Winged 3/8 ID 1.5 OD

**NOTE:** All component dimensions given in U.S. inches  
 1 inch = 25.4 mm

TRACTOR - MODEL NO. LT2317 CMA (96051002105), PROD. NO. 960 51 00-21  
BAGGER 46

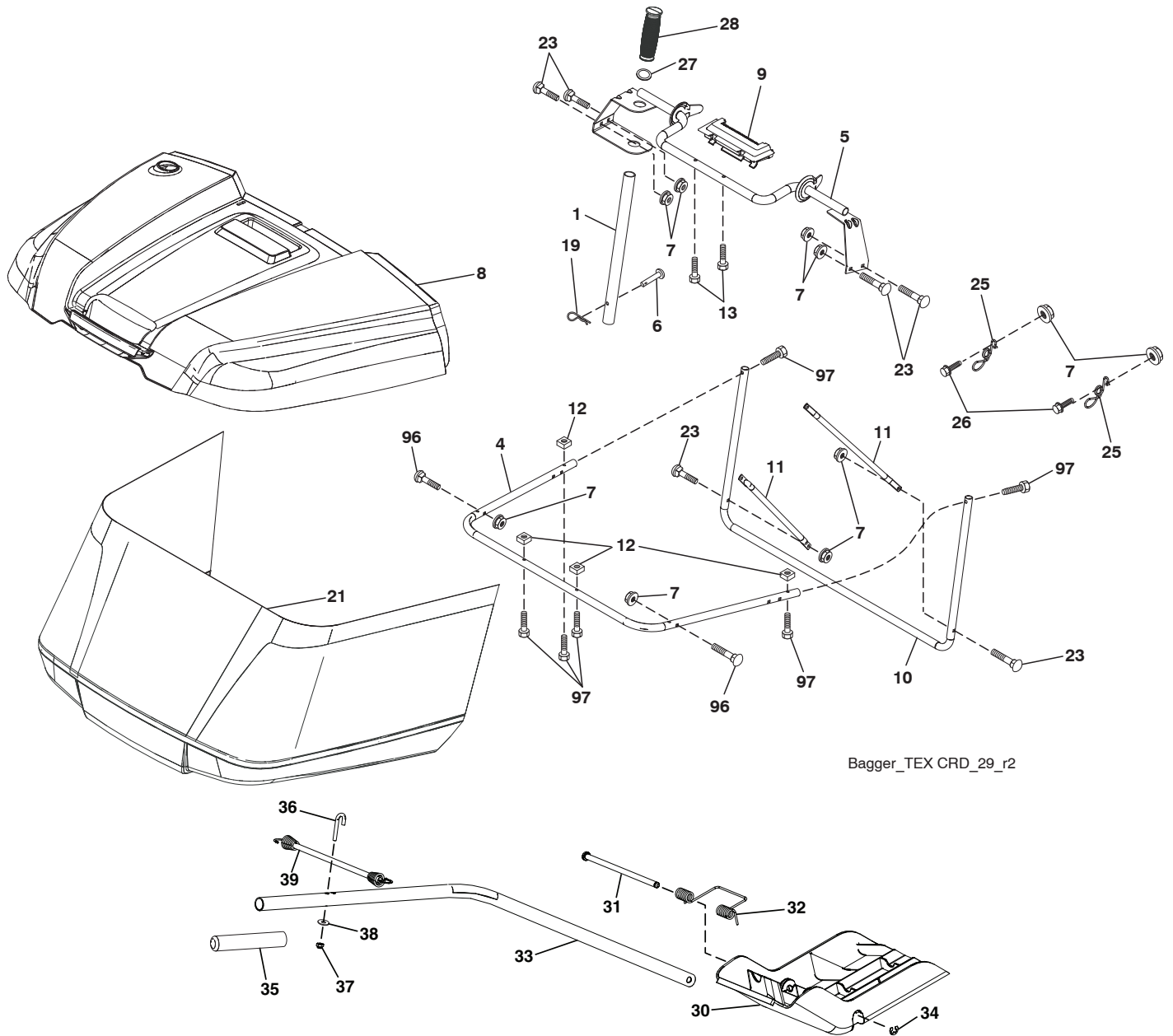

**TRACTOR - MODEL NO. LT2317 CMA (96051002105), PROD. NO. 960 51 00-21  
BAGGER 46**

<b>KEY NO.</b>	<b>PART NO.</b>	<b>DESCRIPTION</b>
1	532 42 86-10	Tube Handle Bagger
4	579 78 54-01	Frame Asm Bagger Top
5	532 41 76-32	Frame Asm Top Bagger
6	532 12 68-75	Rivet Drilled
7	873 90 04-00	Nut Hex Flange 1/4-20 unc
8	532 42 59-54	Cover Bagger
9	532 41 76-29	Insert Handle Bagger
10	532 43 67-70	Frame Front
11	532 43 67-71	Tubing Brace Bagger
12	532 42 17-93	Nut Square 1/4
13	532 42 17-80	Screw 1/4 x 1.150
19	532 19 42-08	Cotter Pin 5/16 Bow Tie
21	532 44 83-07	Bag Asm
23	872 04 04-10	Bolt Carr. 1/4-20
25	532 42 16-14	Spring Latch Bagger
26	817 49 04-12	Screw
27	532 42 12-62	Grommet Rubber
28	532 16 57-87	Grip Handle Black
30	532 43 74-52	Plug Mulch
31	532 43 58-61	Pin Hinge
32	532 43 74-54	Spring Double Torsion
33	532 43 84-51	Shaft
34	532 43 79-88	E-ring
35	532 43 91-39	Grip Mulch
36	532 43 90-98	Bolt J
37	532 06 91-80	Nut Lock
38	819 07-08-18	Washer
39	532 43 92-42	Bungee
96	501 40 66-01	Screw Hex Cap 1/4-20 x 1.50
97	590 10 57-01	Screw Torx Butn HD 1/4-20-1.5"

**NOTE:** All component dimensions given in U.S. inches  
1 inch = 25.4 mm

