

ILLUSTRATED PARTS LIST

MODEL NO. 96051008404

CUSTOMER CATALOG NO. LT2320 CMA2

PRODUCT NO. 960 51 00-84

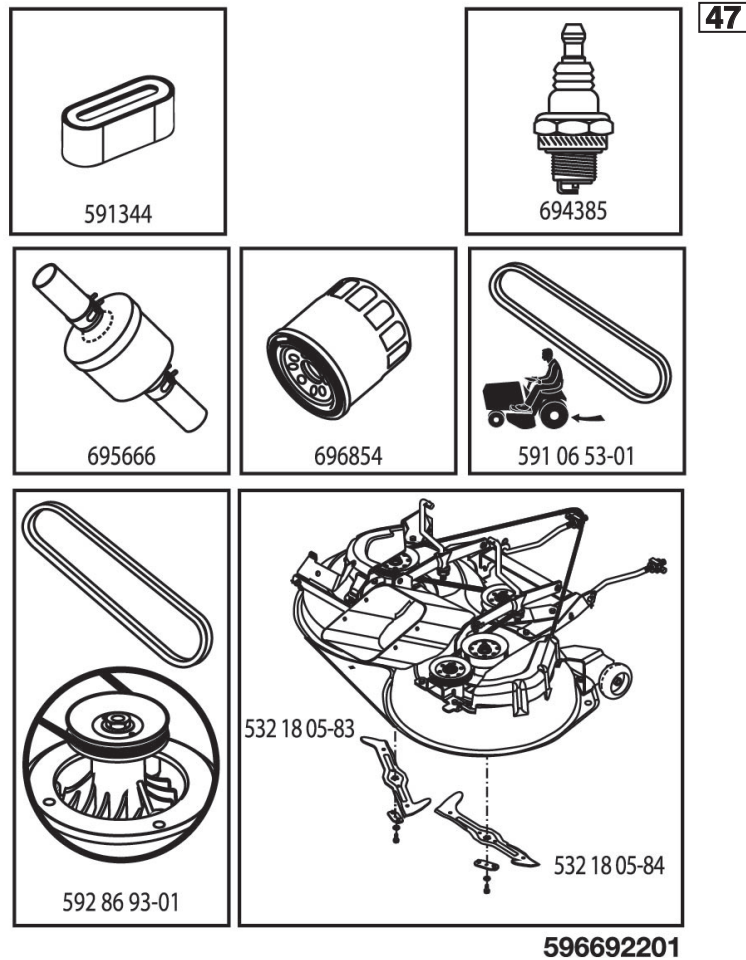

**TRACTOR - - MODEL NO. LT2320 CMA2 (96051008404), PRODUCT NO. 960 51 00-84
DECALS 27**

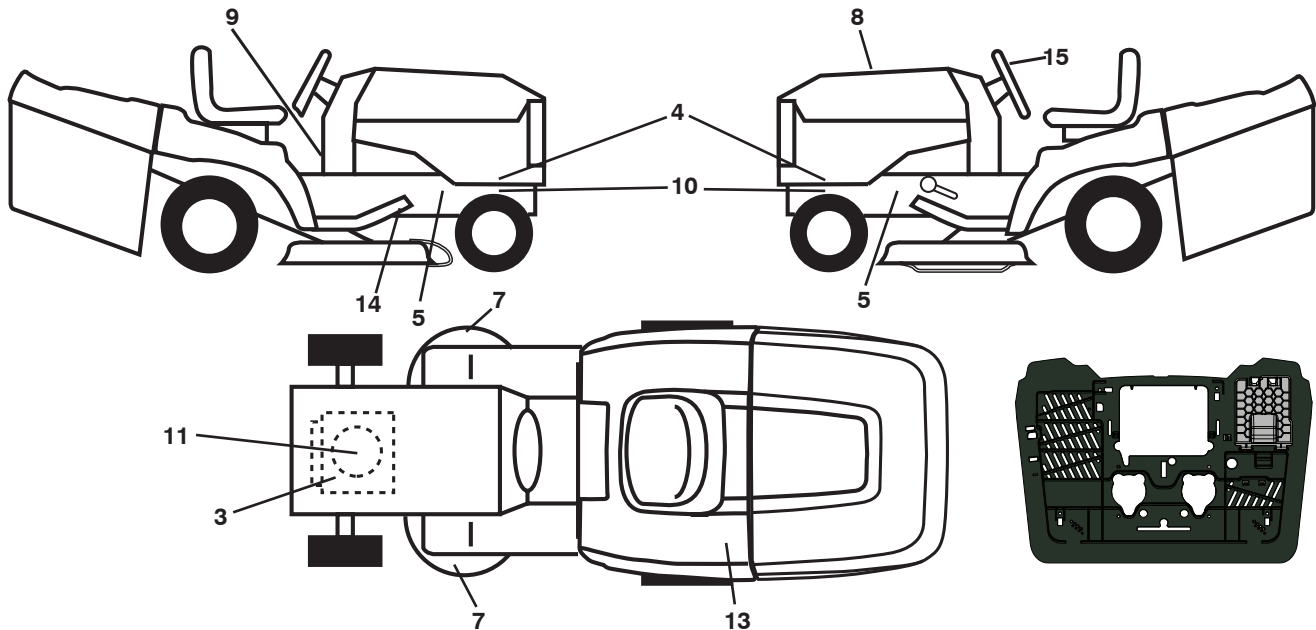

KEY NO.	PART NO.	DESCRIPTION
3	581 57 97-01	Decal, Engine Warning
4	582 29 52-01	Decal, Hood Panel
5	581 57 96-01	Decal, Chassis Hot Muffler
7	581 57 91-01	Decal, Cutfinger CE
8	596 69 22-01	Decal, Rpl.
9	581 57 84-01	Decal, Instruction MLCH/BG
10	581 57 98-01	Decal, Warning Service/Fire
11	590 02 41-01	Decal, Engine B&S
13	581 57 83-01	Decal, Warning

KEY NO.	PART NO.	DESCRIPTION
14	592 98 02-01	Decal, Deck Belt Sch.
15	590 75 56-01	Decal, Steering
--	532 44 46-19	Decal, Bypass
--	532 42 59-76	Pad, Footrest, LH
--	532 42 59-86	Pad, Footrest, RH
--	114 07 92-20	Manual Operator's (Euro)
--	114 07 93-10	Manual Operator's (Scan)
--	114 07 94-50	Manual Operator's (EBloc)
--	114 07 95-40	Manual Operator's (Baltic)

WHEELS AND TIRES

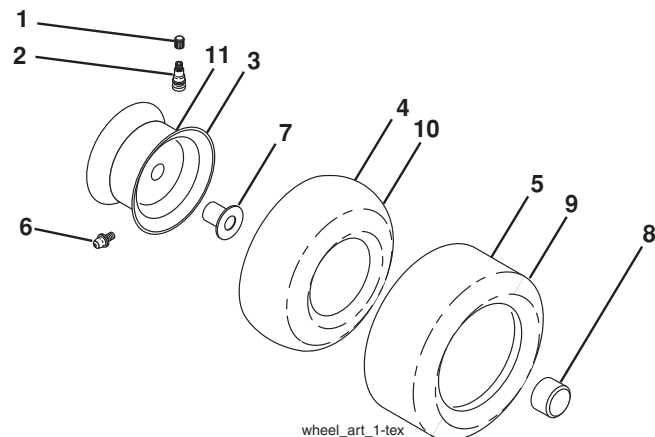

KEY NO.	PART NO.	DESCRIPTION
1	532 05 91-92	Cap Valve Tire
2	532 06 51-39	Stem Valve
3	532 13 83-36	Rim Asm. 6" Front
4	532 05 99-04	Tube Front (Service Item Only)
5	532 10 62-22	Tire Front 15 x 6-6
6	532 12 49-57	Fitting Grease (Front Wheel Only)
7	532 12 49-59	Bearing Flange (Front Wheel Only)
8	532 17 50-39	Cap Axle Blk. 1 50 x 1 00
9	532 42 05-31	Tire Rear 18 x 9.5-8
10	532 12 49-26	Tube Rear (Service Item Only)
11	532 13 83-37	Rim Asm. 8" Rear
--	532 14 43-34	Sealant, Tire (10 oz. Tube)

NOTE: All component dimensions given in U.S. inches
1 inch = 25.4 mm

TRACTOR - - MODEL NO. LT2320 CMA2 (96051008404), PRODUCT NO. 960 51 00-84 SCHEMATIC **38**

SCH26

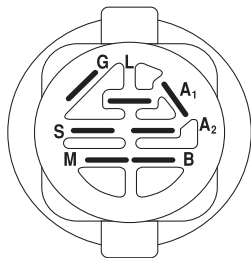
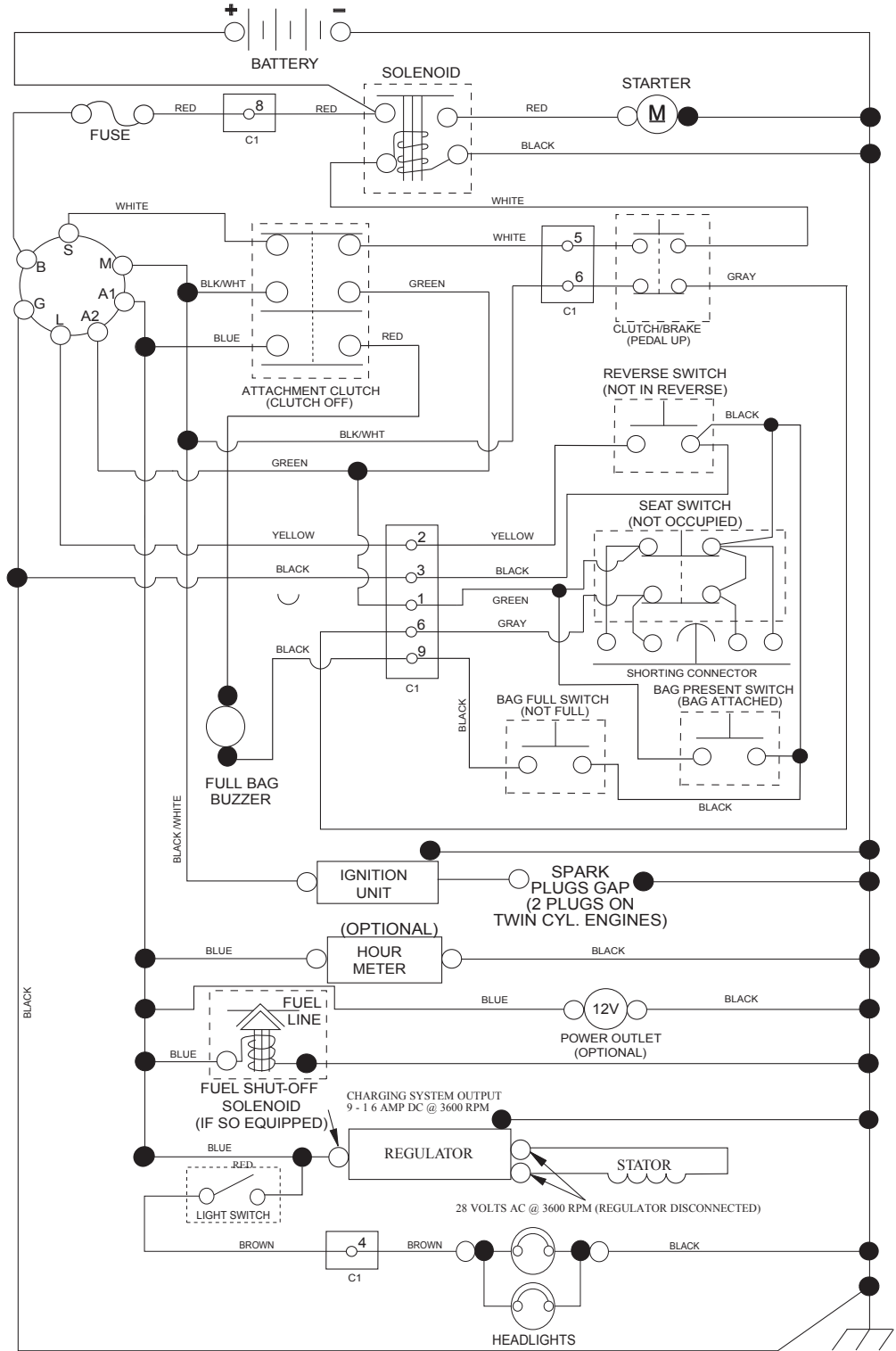

IGNITION SWITCH

POSITION	CIRCUIT	"MAKE"
OFF	M+G+A1	
RUN/OVERRIDE	B+A1	
RUN	B+A1	L+A2
START	B + S + A1	

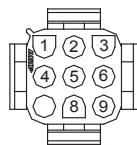

CHASSIS HARNESS CONNECTOR (C1) (MATING SIDE)

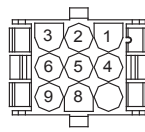

DASH HARNESS CONNECTOR (C2) (MATING SIDE)

WIRING INSULATED CLIPS
NOTE: IF WIRING INSULATED CLIPS WERE REMOVED FOR SERVICING OF UNIT, THEY SHOULD BE RE-INSTALLED TO PROPERLY SECURE YOUR WIRING.

●
NON-REMOVABLE CONNECTIONS

○
REMOVABLE CONNECTIONS

TRACTOR - - MODEL NO. LT2320 CMA2 (96051008404), PRODUCT NO. 960 51 00-84
ELECTRICAL 32

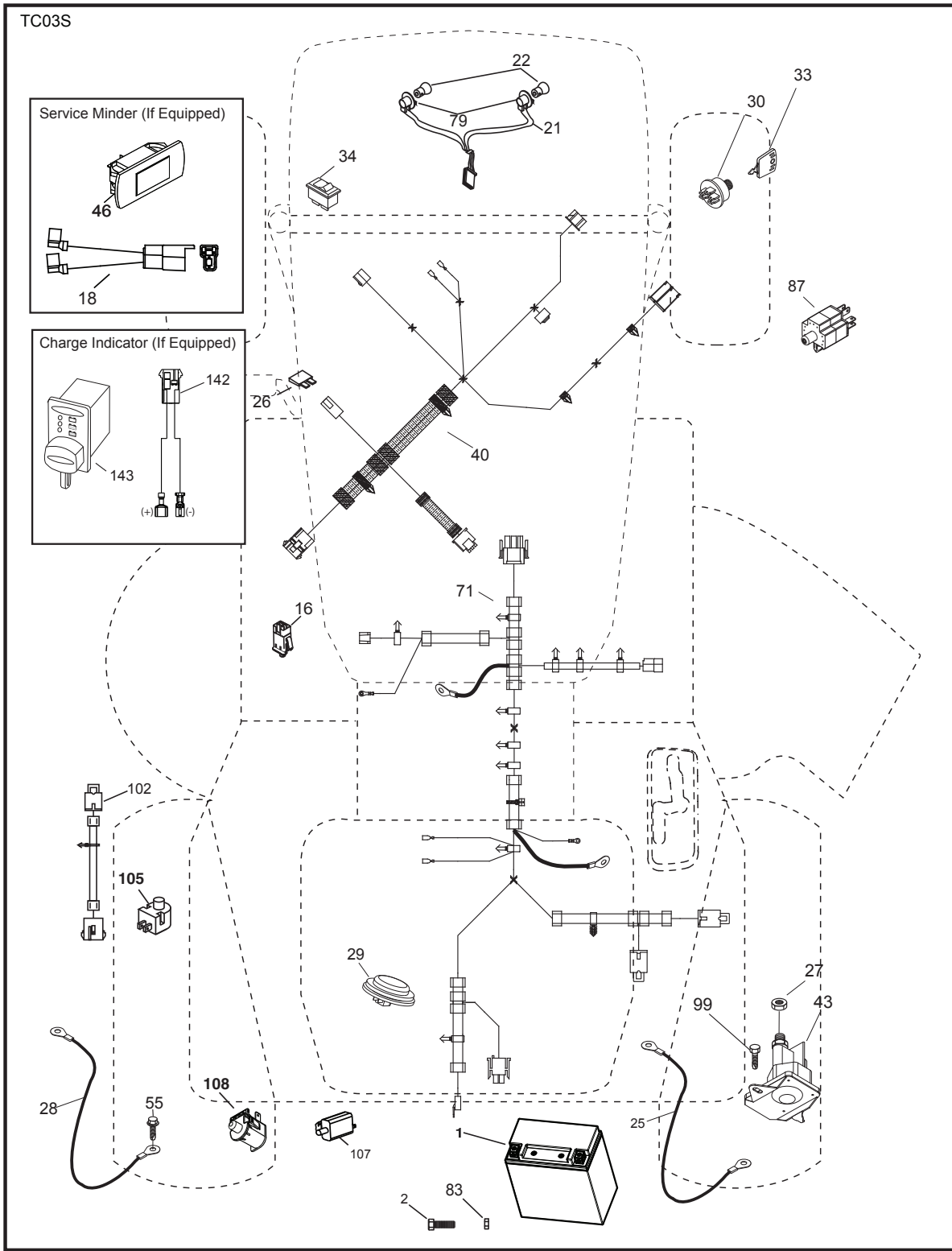

**TRACTOR - - MODEL NO. LT2320 CMA2 (96051008404), PRODUCT NO. 960 51 00-84
ELECTRICAL **32****

KEY NO.	PART NO.	DESCRIPTION
1	532 43 71-57	Battery
2	532 44 09-23	Screw Hex Hd Cap M6 x 1.12MM
16	532 17 61-38	Switch Interlock Push-In
21	532 40 02-52	Harness Light w/4152J
22	532 00 41-52	Bulb Light
25	532 44 13-82	Cable Starter
26	532 17 51-58	Fuse
27	873 51 04-00	Nut Keps Hex 1/4-20 unc
28	532 44 13-83	Cable, Ground
29	532 40 15-45	Switch, Seat
30	532 19 33-50	Switch, Ign
33	532 41 19-35	Key/Chain
34	532 11 07-12	Switch Light/Reset
40	532 42 10-02	Harness Ign. Dash
43	582 04 28-01	Solenoid
46	586 16 18-01	Gauge Serviceminder Hrmtr
55	817 06 05-12	Screw Thdrol 5/16-18 x 3/4 TYTT
71	532 44 08-20	Harness Ignition Chassis
79	532 17 52-42	Socket Asm. Bulb
83	532 43 67-74	Nut Square M6 x 1.8.5 x 11MM
87	532 42 10-60	Switch Railmount
99	817 00 05-12	Bolt Hex Washer Head 25-20 x.75
102	532 44 12-62	Harness Jumper
105	532 40 75-68	Switch Reverse
107	532 18 03-79	Switch Full Bagger
108	532 42 10-62	Switch Snapmount

NOTE: All component dimensions given in U.S. inches
1 inch = 25.4 mm

TRACTOR - - MODEL NO. LT2320 CMA2 (96051008404), PRODUCT NO. 960 51 00-84
CHASSIS AND ENCLOSURES **39**

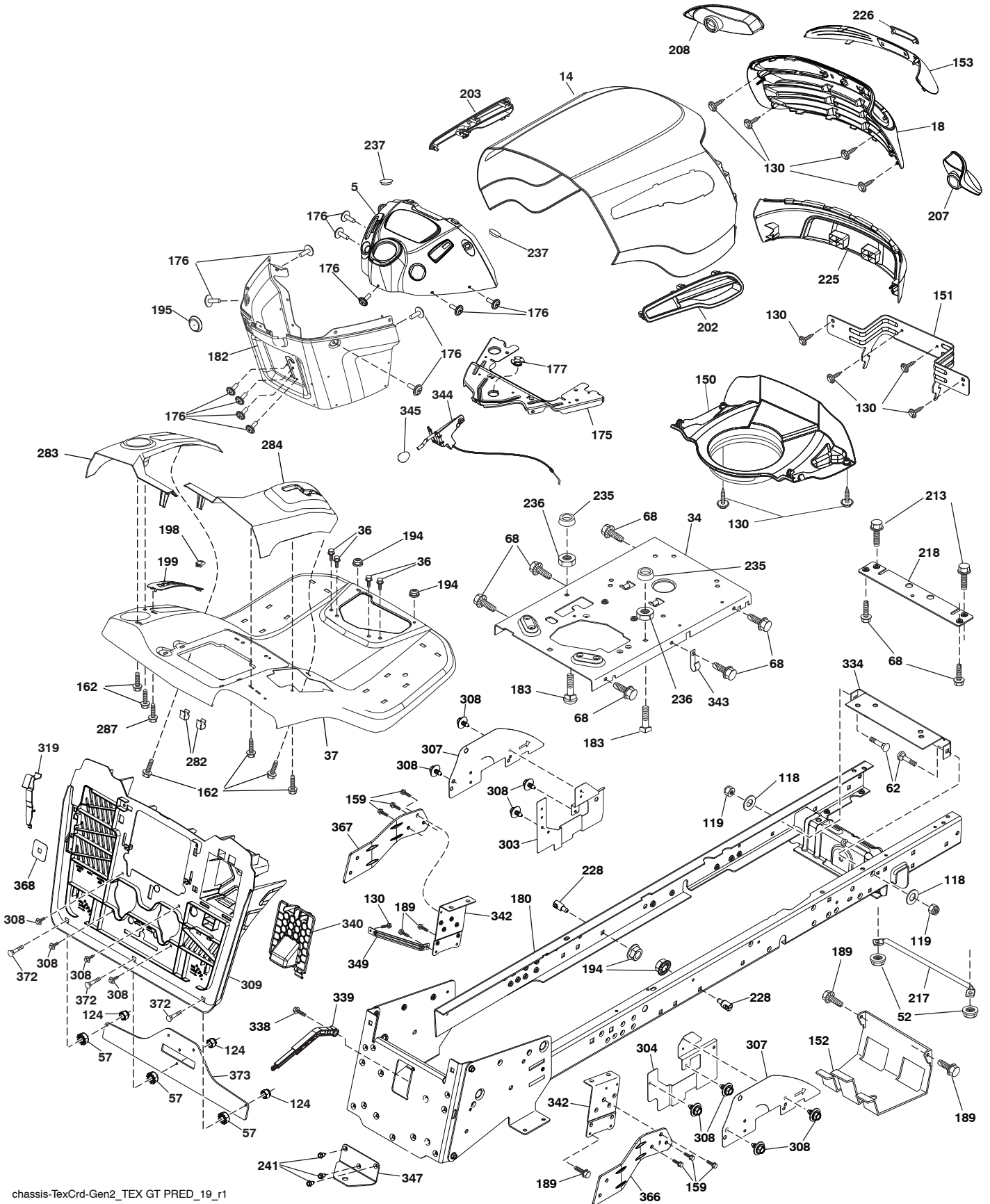

chassis-TexCrd-Gen2_TEX GT PRED_19_r1

**TRACTOR - - MODEL NO. LT2320 CMA2 (96051008404), PRODUCT NO. 960 51 00-84
CHASSIS AND ENCLOSURES **39****

KEY NO.	PART NO.	DESCRIPTION	KEY NO.	PART NO.	DESCRIPTION
5	585 52 98-05	Dash	218	532 19 63-95	X-Piece Hood Stop
14	532 44 38-24	Hood	225	593 81 78-01	Bumper Grille
18	532 42 73-33	Grille	226	532 42 47-16	Logo
34	580 91 09-01	Plate Engine	228	532 19 51-61	Stud Fastener
36	817 06 05-12	Screw 5/16-18 x 3/4	235	532 40 61-29	Spacer Fender
37	532 44 22-31	Fender	236	873 93 05 00	Nut Center Lock 5/16-18 unc
52	873 68 05-00	Nut Crownlock 5/16-18	237	532 40 37-04	Plug Mount Cargo
57	873 51 04-00	Nut Keps w/insert 1/4-20 unc	241	817 06 05-16	Screw 5/16-18 x 1 SMGML TAP
62	872 11 06-08	Bolt 3/8-16 x a Gr. 5	282	532 41 41-10	Clip Retainer
68	539 99 08-58	Screw Thdrol. 5/16-18 x 1/2	283	532 44 76-71	Console Deck Lift
118	819 13 13-16	Washer 13/32 x 13/16 x 16	284	532 44 72-11	Console Shift RH
119	873 68 06-00	Nut Crownlock	287	817 60 04-06	Screw Hex Washhead. 1/4-20 x 3/8
124	539 97 69-78	Nut Lock 1/4-20 Hx.	303	589 00 76-02	Shield, Chassis French LH
130	532 41 63-58	Screw #10 x .750 BOS Thread	304	589 00 68-02	Shield, Chassis French RH
150	584 86 29-01	Air Duct	307	587 49 45-01	Shield, Chassis Upper
151	532 44 54-94	Bracket Pivot	308	532 17 18-77	Bolt 5/16-18 unc x 3/4
152	532 19 95-35	Shield Browning	309	581 32 89-11	Backplate
153	532 42 47-17	Lens Bar	319	581 31 39-06	Lever Bagger Presence
159	817 00 06-12	Screw 3/8-16 x 3/4	334	532 44 25-37	Bracket Engine
162	532 14 24-32	Screw Hex Wsh. Hi-Lo 1/4 x 1/2 unc	338	532 43 66-40	Bolt Shoulder
175	590 60 77-02	Crossmember	339	532 43 66-41	Lever Bagger Full
176	532 40 07-76	Screw 10-24 x 5/8	340	581 32 90-01	Door Battery Tray
177	532 19 52-28	Bushing Steering	342	582 82 68-02	Support Fender
180	583 90 27-01	Chassis	343	532 44 07-49	Clip
182	532 43 89-67	Dash Lower	344	532 43 89-70	Control EZ Mulch
183	874 52 05-20	Bolt 5/16-18 x 1-1/4	345	532 44 06-39	Knob Oval
189	817 00 05-12	Screw 5/16-18 x 3/4	347	532 44 28-87	Hitch Tow
194	873 90 05-00	Nut Lock Hex Flange 5/16-18	349	532 43 66-06	Bracket Support
195	532 40 41-37	Plug Hole Dash Lower	366	581 31 46-02	Bracket RH Front
198	532 44 15-52	Indicator Deck Lift	367	581 31 45-02	Bracket LH Front
199	532 41 87-39	Plate Deck Lift	368	581 42 48-01	Shroud Bagger Full Lever
202	591 16 45-01	Side Vent RH	372	592 80 78-01	Bolt 1/4-20 x 3/4
203	591 16 45-02	Side Vent LH	373	586 29 98-03	Backplate Support
207	532 19 89-63	Bezel Grille RH	--	532 40 09-44	Kit Bumper
208	532 19 89-64	Bezel Grille LH			
213	539 97 69-34	HCS 5/16-18 x 3/4 Gr. 5 ZD			
217	532 40 91-67	Rod Pivot Hood			

NOTE: All component dimensions given in U.S. inches
1 inch = 25.4 mm

**TRACTOR - - MODEL NO. LT2320 CMA2 (96051008404), PRODUCT NO. 960 51 00-84
DRIVE **40****

KEY NO.	PART NO.	DESCRIPTION	KEY NO.	PART NO.	DESCRIPTION
1	---	Transaxle, Tufftorq K46DF (446488) (Order parts from transaxle manufacturer.)	189	532 43 36-11	Bellcrank Grounddrive
2	532 12 35-83	Key Square	195	580 45 69-01	Bracket Brake Rod
6	532 12 40-28	Bushing	203	819 11 11-16	Washer 11/32 x 11/16 x 16 Ga.
17	532 43 62-27	Spring, Brake	205	532 12 17-48	Washer 25/32 x 1-5/8 16 Ga.
26	532 19 96-79	Spring Return	206	532 44 85-96	Bracket Mount Latch
27	817 49 05-28	Screw Hexwsh Thd. 5/16-18 x 1-3/4	207	587 03 14-01	Latch Control
29	532 44 27-95	Rod, Brake	208	532 19-78-69	Gear Sector Control Cruise
30	819 13 16-16	Washer 13/32 x 1 x 16 Ga.	209	532 19 95-92	Rod Control Cruise
33	812 00 00-01	Ring E	210	532 40 09-80	Rocket Asm Pedal
35	583 86 45-01	Rod, Brake, Park	211	532 12 01-83	Bearing Nylon
37	532 18 89-67	Washer Hard. .793 x 1.637 x 0.60	213	532 40 31-19	Knob Control Cruise
38	532 16 96-13	Nyliner Snap In	214	532 42 12-63	Pedal Forward Pad
42	532 12 48-72	Cover, Foot Pedal	215	532 41 94-82	Pedal Reverse Pad
49	872 11 06-14	Bolt Rdhd 3/8-16 unc x 1-3/4 Gr. 5	221	532 40 31-87	Retainer Spring Clip
50	532 19 43-27	Idler Flat	222	879 21 20-10	Washer 21/32 x 1-1/4
51	873 90 06-00	Lock Nut 3/8-16	226	532 40 15-64	Bracket Mount
52	532 19 43-26	Idler V-Groove	227	817 49 05-12	Screw
56	591 06 53-01	V-Belt, Drive	279	532 44 42-83	Link Asm.
61	532 44 51-51	Pulley Transaxle	280	819 11 10-12	Washer 11/32 x 5/8 x 12 Ga.
64	532 19 78-65	Shaft Asm.	309	532 16 55-81	Plaste Fstr
73	874 49 05-44	Bolt Hex Flghd 5/16-18 Gr. 5	311	532 16 98-45	Washer Nylon
90	532 44 36-05	Keeper Belt Clutching	312	532 16 56-14	Hub Tapered Round
92	874 76 05-20	Bolt Fin. Hex 5/16-18 unc x 1.25	313	874 78 04-16	Bolt Hex Fin 1/4-20 x 1 Gr. 5
99	532 44 39-47	Rod Bypass	314	532 44 47-13	Belt Keeper
103	873 35 05-00	Nut	315	817 58 05-20	Screw Thdrol 5/16-18 x 4.25
116	873 90 05-00	Nut Lock Hex Flange 5/16-18	335	532 19 95-34	Pulley V-Idler
125	817 00 05-12	Screw 5/16-18 x 3/4	336	587 25 96-01	Bolt 5/16-18 x 1-3/4 Flanged
140	810 04 04-00	Washer Lock Hvy. Helical 1/4	339	532 43 68-67	Strap Torque K46 CRD Tex
143	539 99 08-58	Screw Thdrol 5/16-18 x 1/2	342	532 18 26-82	Keeper Belt 2.5
159	876 02 04-12	Pin Cotter 1/8 x 3/4	343	539 11 28-99	Nut 5/16-18 Hex Flanged
160	532 16 94-84	Retainer Clip	351	532 43 69-98	Bracket 97
161	532 10 57-09	Spring, Return, Clutch	352	532 43 56-45	Bracket Idler CRD Tex
163	532 44 27-93	Rod Control	355	532 43 56-69	Strap Torque K46
166	532 42 91-64	Nut Push .625	359	817 49 06-10	Screw Hxwh. Thdr. 3/8-16 x 5/8
167	532 40 52-57	Latch Brake Parking	360	532 44 47-14	Nut Hex Centerlock 5/16-24 unf
175	532 42 93-59	Shaft Shift Tapered	362	532 43 68-12	Idler Flat 2.25"
183	532 13 70-57	Spacer Axle	363	532 44 27-80	Spacer 343 x 63 x .62
184	587 65 37-01	Handle Parking Break	364	532 44 30-32	Bracket Idler
185	872 11 06-22	Bolt Rdhd 3/8-16 unc x 2-3/4 Gr. 5	372	582 65 49-01	Keeper Belt Transaxle
186	532 19 43-21	Spacer Retainer			
188	582 21 70-01	Link Clutch Ground Drive, Long			

NOTE: All component dimensions given in U.S. inches
1 inch = 25.4 mm

**TRACTOR - - MODEL NO. LT2320 CMA2 (96051008404), PRODUCT NO. 960 51 00-84
ENGINE 24**

KEY NO.	PART NO.	DESCRIPTION
1	---	Engine B&S Model No. 40N877-0009-B1 (501258001)(Order parts from engine manufacturer.)
2	532 14 97-23	Muffler
9	501 83 26-02	Keeper Belt Engine
12	586 47 85-01	Pulley Engine
15	581 29 01-01	Tank Fuel 2.0
18	532 43 02-20	Cap Fuel
20	532 42 35-02	Control Throttle/Choke
21	532 41 63-58	Screw #10 x 0.750 BOS Thread
28	532 13 70-40	Fuel Line
29	532 13 71-80	Spark Arrester Kit
37	532 12 34-87	Clamp Hose
42	539 99 02-47	Lock Washer Hvy. 7/16
43	817 06 05-16	Screw 5/16-18x1
45	873 51 04-00	Nut Keps Hex 1/4-20 unc
62	532 43 40-17	Shield Heat Muffler
69	532 16 53-91	Gasket
70	581 88 11-01	Exhaust Tube LH
71	581 88 10-01	Exhaust Tube RH
79	532 18 39-06	Screw Socket HD 5/16-18 x 1
81	532 14 84-56	Tube Drain Oil Easy
82	532 42 82-87	Valve Oil Drain
84	817 06 06-20	Screw 3/8-16 x 1-1/4
85	501 60 65-01	Bolt Hex 7/16-20 x 4 x Gr. 5-1.5
90	817 00 06-16	Screw 3/8-16 x 1
96	819 09 14-16	Washer 9/32 x 7/8 x 16 Ga.
97	817 67 04-12	Screw 1/4-20 x 3/4
102	817 00 05-12	Screw 5/16-18 x 3/4
108	587 17 95-10	Cover Pulley Engine w/SHLD

NOTE: All component dimensions given in U.S. inches
1 inch = 25.4 mm

Engine Power Rating Information

The gross power rating for individual gas engine models is labeled in accordance with SAE (Society of Automotive Engineers) code J1940 (Small Engine Power & Torque Rating Procedure), and rating performance has been obtained and corrected in accordance with SAE J1995 (Revision 2002-05). Torque values are derived at 3060 RPM; horsepower values are derived at 3600 RPM. Actual gross engine power will be lower and is affected by, among other things, ambient operating conditions and engine-to-engine variability. Given both the wide array of products on which engines are placed and the variety of environmental issues applicable to operating the equipment, the gas engine will not develop the rated gross power when used in a given piece of power equipment (actual "on-site" or net power). This difference is due to a variety of factors including, but not limited to, accessories (air cleaner, exhaust, charging, cooling, carburetor, fuel pump, etc.), application limitations, ambient operating conditions (temperature, humidity, altitude), and engine-to-engine variability. Due to manufacturing and capacity limitations, Briggs & Stratton may substitute an engine of higher rated power for this Series engine.

TRACTOR - - MODEL NO. LT2320 CMA2 (96051008404), PRODUCT NO. 960 51 00-84
STEERING ASSEMBLY **41**

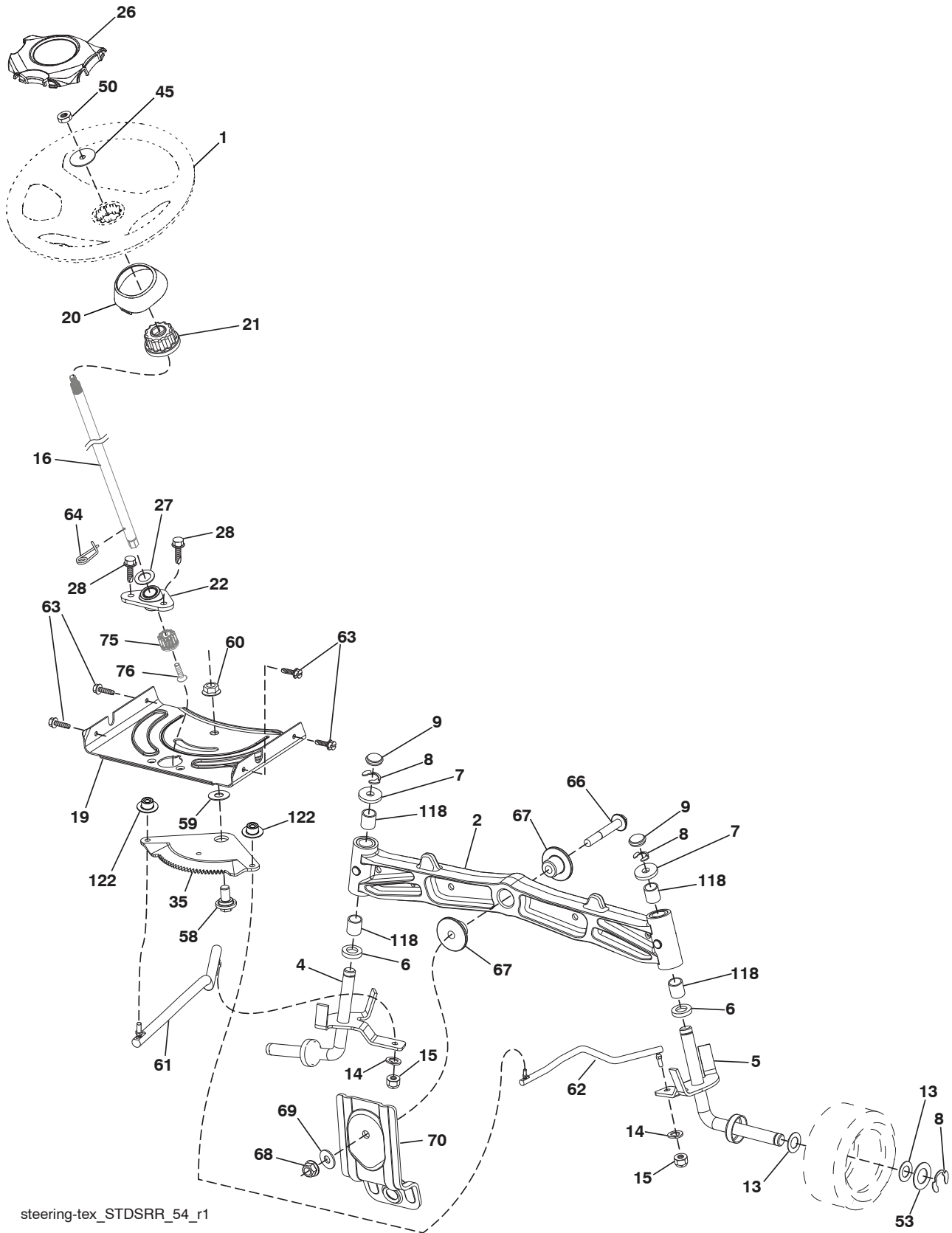

steering-tex_STDSRR_54_r1

**TRACTOR - - MODEL NO. LT2320 CMA2 (96051008404), PRODUCT NO. 960 51 00-84
STEERING ASSEMBLY **41****

KEY NO.	PART NO.	DESCRIPTION
1	532 42 41-46	Wheel, Steering
2	532 41 35-91	Axle Asm., Front
4	532 40 30-87	Spindle Asm., LH
5	532 40 30-88	Spindle Asm., RH
6	532 12 49-31	Bearing, Race Thrust Harden
7	532 12 17-48	Washer 25/32 x 1-5/8 x 16 Ga.
8	812 00 00-29	Ring, Klip #T5304-75
9	532 12 12-32	Cap, Spindle
13	532 12 17-49	Washer 25/32 x 1-1/4 x 16 Ga.
14	539 99 01-18	Washer, SLW ZD 3/8
15	873 54 06-00	Nut, Crown Lock 3/8-24 unf
16	587 01 60-02	Steering Shaft
19	532 19 47-29	Plate Steering
20	532 42 47-40	Steering Boot
21	586 84 02-01	Adapter Wheel Steering
22	585 02 98-02	Bearing
26	532 42 41-47	Insert, Wheel Steering
27	819 21 16-16	Washer
28	817 00 06-12	Screw 3/8-16 x 3/4
35	532 19 47-32	Gear, Sector
45	587 01 64-01	Washer 3/8 ID 2-3/8 OD 12 Ga. PLTD
50	873 90 06-00	Nut Lock Flg 3/8-16 unc
53	532 18 89-67	Washer Hardened .793 x 1.637 x .060
58	532 19 47-47	Bolt Shoulder Sector Pivot CFM
59	532 19 47-48	Washer Thrust Sector Steering
60	873 97 10-00	Nut Flange Lock 5/8-11
61	532 19 47-40	Draglink LH
62	532 19 47-41	Draglink, RH
63	817 00 05-12	Screw 5/16-18 x 3/4
64	532 19 98-49	Retainer Clip Spring Steering
66	871 02 07-48	Bolt Hex Fghd 7/16-14 x 3 Serr
67	532 19 47-37	Bushing PM Front Axle
68	873 90 07-00	Nut Lock Flange 7/16-14 Gr. 5
69	532 19 91-62	Washer 1.5 x .505 x .118
70	585 33 88-01	Bracket Deck Susp. Front
75	580 68 37-01	Pinion
76	580 68 36-01	Screw Head Sock
118	532 40 60-13	Bushing
122	532 44 49-62	Cap Gear

NOTE: All component dimensions given in U.S. inches
1 inch = 25.4 mm

TRACTOR - - MODEL NO. LT2320 CMA2 (96051008404), PRODUCT NO. 960 51 00-84
MOWER DECK 44

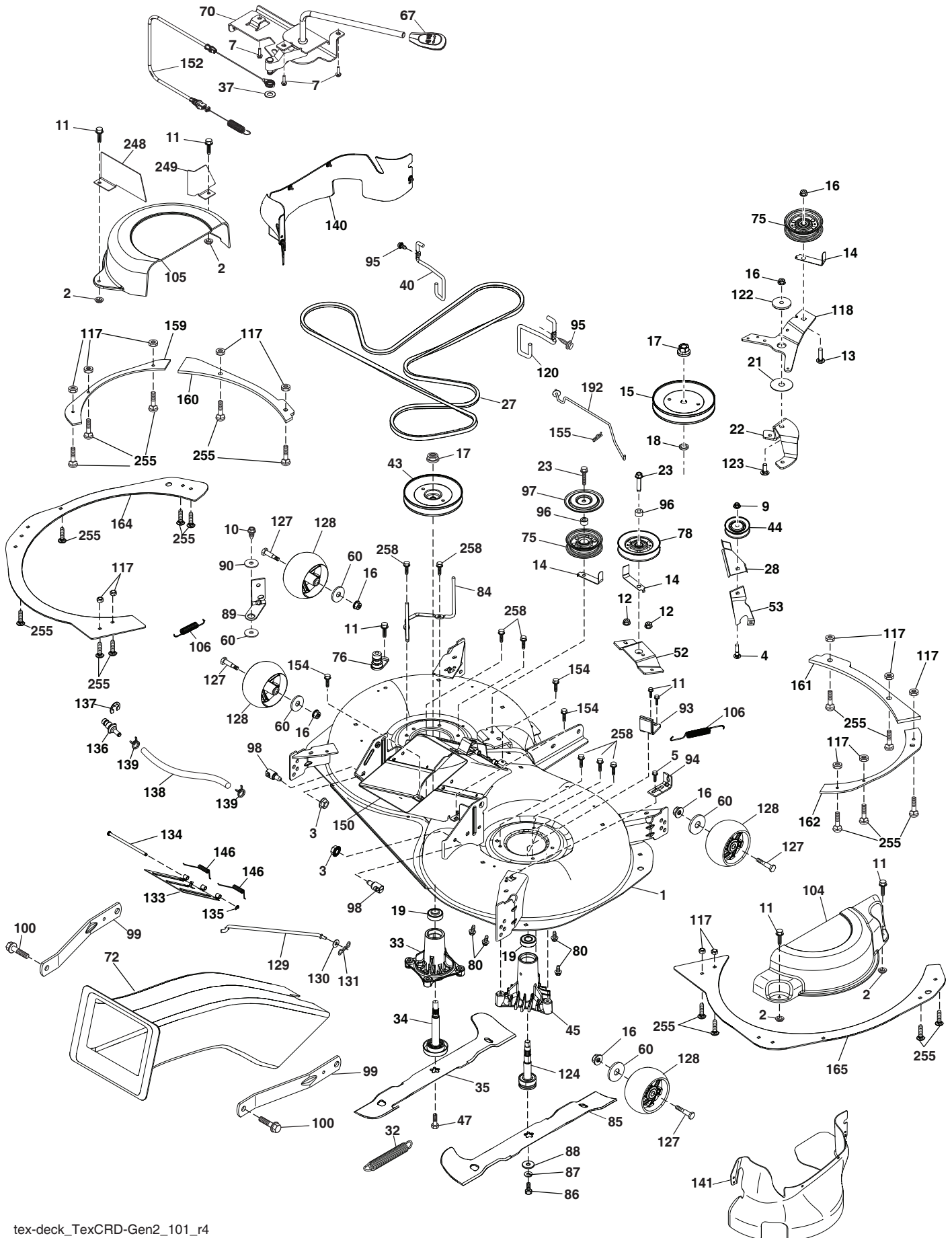

TRACTOR - - MODEL NO. LT2320 CMA2 (96051008404), PRODUCT NO. 960 51 00-84
MOWER DECK 44

KEY NO.	PART NO.	DESCRIPTION	KEY NO.	PART NO.	DESCRIPTION
1	596 77 95-01	Kit Deck Weldment	99	532 19 51-86	Arm Suspension Mower Rear
2	532 42 30-62	Palnut 1/4	100	532 19 65-39	Bolt Shoulder
3	873 90 05-00	Nut Lock Hex Flange 5/16-18	104	592 86 57-01	Mandrel Cover RH
4	872 11 05-10	Bolt Carriage 5/16-18 x 1-1/4 Gr. 5	105	532 44 47-55	Mandrel Cover LH
5	817 00 05-10	Bolt 5/16-18	106	532 19 32-16	Spring Brake Return
7	532 41 63-58	Screw #10 x 0.750 BOS Thread	117	873 90 04-00	Nut Hex Fig 1/4-20
9	585 69 13-01	Nut Hex Flg 5/16-18	118	592 86 58-02	Arm Clutching
10	817 00 06-16	Screw 3/8-16 x 1 smgml tap	120	532 19 72-59	Keeper Belt RH
11	532 13 77-29	Screw Thd Roll 1/4-20 X 5/8	122	532 16 57-23	Spacer Retainer
12	539 11 28-99	Nut Hex Flg 5/16-18	123	872 11 06-10	Bolt RDHD 3/8-16 x 1.25
13	872 11 06-12	Bolt Carr Sh 3/8-16 X 1-1/2 Gr. 5	124	532 16 54-82	Shaft Asm Mndrel Short
14	532 15 60-85	Keeper Belt Idler	127	532 19 34-06	Bolt Shoulder 3/8-16 x 3-5/8 Gr. 5
15	532 19 59-45	Pulley Mandrel	128	589 52 73-01	Wheel Gauge
16	873 90 06-00	Nut Lock FIG 3/8 - 16 unc	129	532 44 32-37	Rod Anti-Sway
17	532 40 02-34	Nut Flange Lock Top	130	819 13 13-12	Washer 13/32 x 13/16 x 12 Ga.
18	532 18 76-90	Washer Spacer	131	532 19 42-08	Pin Cotter 5/16 Bow Tie Lock
19	585 32 39-01	Bearing Mandrel	133	532 43 81-97	EZ Mulch Door
21	532 17 85-15	Washer Flat Hardened	134	532 43 58-61	Pin Hinge
22	592 85 47-02	Bracket Clutching Arm	135	532 43 79-88	E-Ring 5/16
23	817 49 06-28	Screw Thdrol 3/8-16 X 1-3/4	136	532 43 96-39	Washout Port Remote
27	532 44 27-81	V-Belt Drive	137	812 00 00-29	Ring Klip
28	592 86 59-02	Idler Keeper	138	582 82 66-01	Washout Port Hose
32	532 40 18-72	Spring Return Deck	139	532 44 07-42	Hose Clamp
33	532 18 72-81	Mandrel Housing, 4 pt.	140	501 58 00-01	Guard French LH
34	587 25 65-01	Shaft, Asm, Mandrel	141	501 57 96-02	Guard French RH
35	532 18 05-83	Blade Mower LH	146	532 44 58-96	Spring
37	819 13 13-16	Washer 13/32 x 13/16 x 16 Ga.	150	596 01 30-02	Weldment Chute Lower 107 CRD
40	532 19 72-58	Keeper Belt Engine LH	152	532 44 76-66	Cable Clutch Manual w/Spring
43	532 44 32-39	Pulley Mandrel	154	532 19 98-55	Screw Thd Roll 1/4-20 x 1/2
44	532 19 95-34	Pulley V-Idler Ground	155	532 00 44-97	Retainer Spring 1"
45	532 12 87-74	Mandrel Asm. Short	159	585 30 95-05	Reinforce Plate LHS Bolt
47	584 30 93-01	Screw 7/16-20 x 1 Hex	160	585 30 94-05	Reinforce Plate LHS Ft
52	594 97 26-03	Bracket Center V-Idler	161	585 31 60-05	Reinforce Plate RH Frt
53	594 97 29-03	Bracket Angled V-Idler	162	585 31 61-05	Reinforce Plate RH Sd
60	819 12 14-14	Washer 5/16 Flat STE STD ZD	164	589 35 85-02	Baffle Plate RH Sd
67	532 40 30-12	Handle Clutch Cable	165	587 42 61-02	Baffle Rt
70	532 19 99-72	Clutch Asm Manual	192	592 86 61-02	Link Brake Assy
72	581 45 41-03	Chute Upper	248	589 00 98-02	LH Rear French Steel Guard
75	532 17 34-38	Pulley Idler Flat	249	589 00 97-02	LH Front French Steel Guard
76	532 43 96-40	Washout Port	255	592 80 78-01	Bolt 1/4-20 x 1
78	532 17 39-02	Pulley Idler	258	584 95 39-01	Bolt Hex Washer Hd.313-18 x 1.19
80	539 99 03-16	RHSNB 5/16-18 x 3/4 Gr. 5 ZD	--	587 25 33-01	Mandrel Assembly - Tall (Includes Housing (key #33), Shaft Assembly (key #34), and Bearing (key #19) Only - Pulley/Nut/Washer And Blade Bolt/Washers Not Included)
84	532 44 32-35	Keeper Belt LH Mandrel			Mandrel Assembly - Short (Includes Housing (key #45), Shaft Assembly (key #124), And Bearing Only (key #19) - Pulley/Nut/Washer And Blade Bolt/Washers Not Included)
85	532 18 05-84	Blade Mower RH			Replacement Mower Complete
86	532 18 17-13	Bolt 3/8-24 x 1.50 Gr. 8			
87	539 99 01-18	Washer, SLW ZD 3/8			
88	532 14 02-96	Washer Hard Blade Mower Vented	-	581 65 05-01	
89	532 19 72-61	Arm Brake 97 LH			
90	532 19 90-92	Spacer Retainer			
93	592 85 49-02	Brake Arm RH			
94	532 19 72-50	Bracket Clutch Cable			
95	817 00 06-12	Screw	--	596 77 96-01	
96	532 40 02-71	Spacer			
97	532 18 20-61	Shield Idler Mower			
98	532 19 51-61	Stud Fastener			

NOTE: All component dimensions given in U.S. inches
1 inch = 25.4 mm

TRACTOR - - MODEL NO. LT2320 CMA2 (96051008404), PRODUCT NO. 960 51 00-84
MOWER LIFT 45

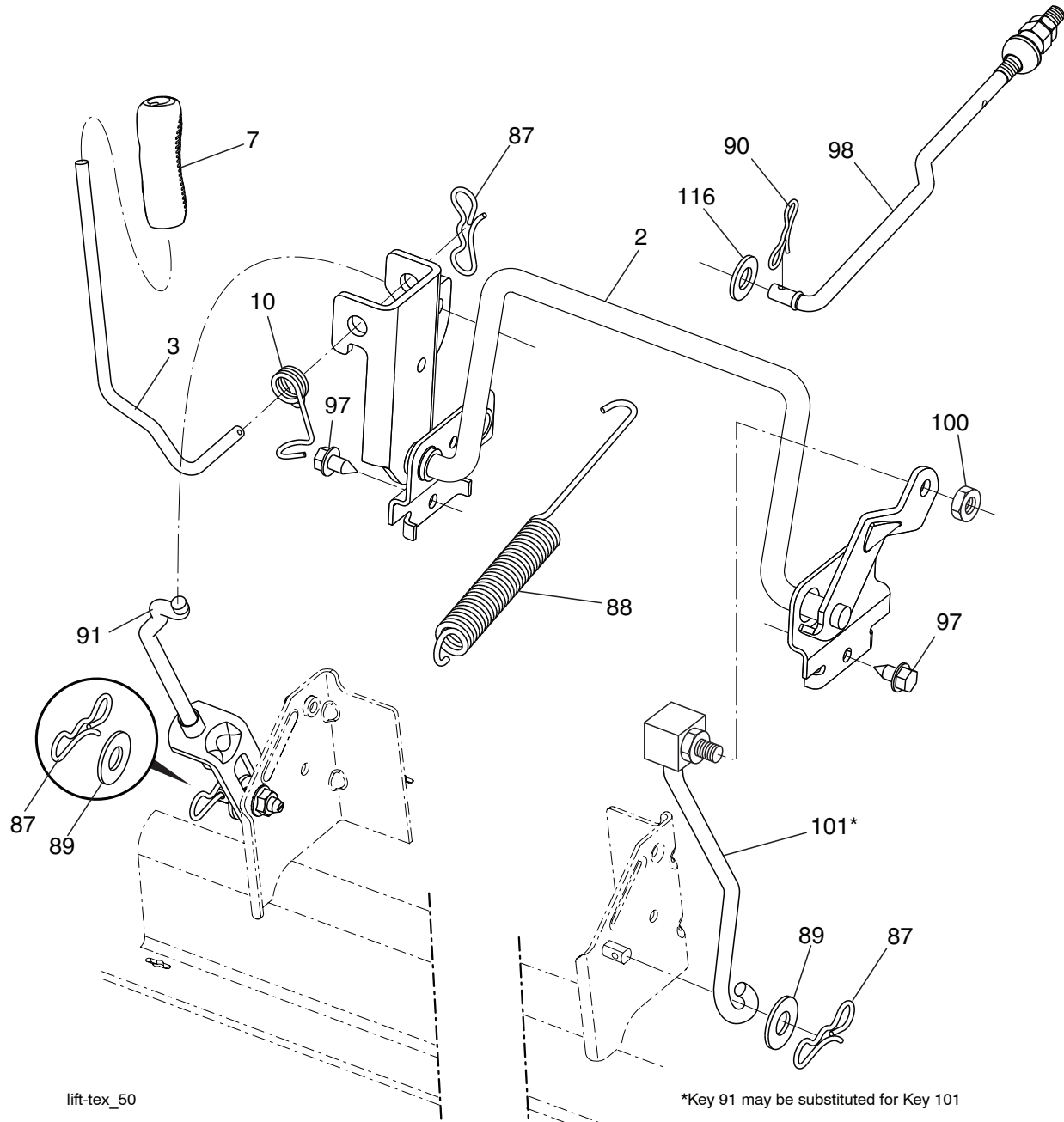

KEY NO.	PART NO.	DESCRIPTION
2	532 43 69-96	Deck Lift Weldment
3	532 19 52-31	Lever Asm., Lift RH
7	580 96 23-01	Grip, Lever
10	532 19 63-14	Spring Torsion
87	532 19 42-09	Pin Cotter 7/16 Bow Tie Lock
88	532 44 54-96	Spring Lift Assist
89	819 19 19-12	Washer Clear Zinc
90	532 19 42-08	Pin Cotter 5/16 Bow Tie Lock
91	532 19 51-81	Link Lift Susp. Mower Rear

KEY NO.	PART NO.	DESCRIPTION
97	817 49 06-08	Screw 3/8-16 x 1/2
98	532 19 52-70	Link Lift Susp. Front Mower
100	873 93 06-00	Nut Centerlock 3/8-16
101	532 40-70-03	Link Asm. Lift FXD
116	819 15 15-16	Washer 15/32 x 15/16 x 16 Ga.

NOTE: All component dimensions given in U.S. inches
 1 inch = 25.4 mm

**TRACTOR - - MODEL NO. LT2320 CMA2 (96051008404), PRODUCT NO. 960 51 00-84
SEAT ASSEMBLY 42**

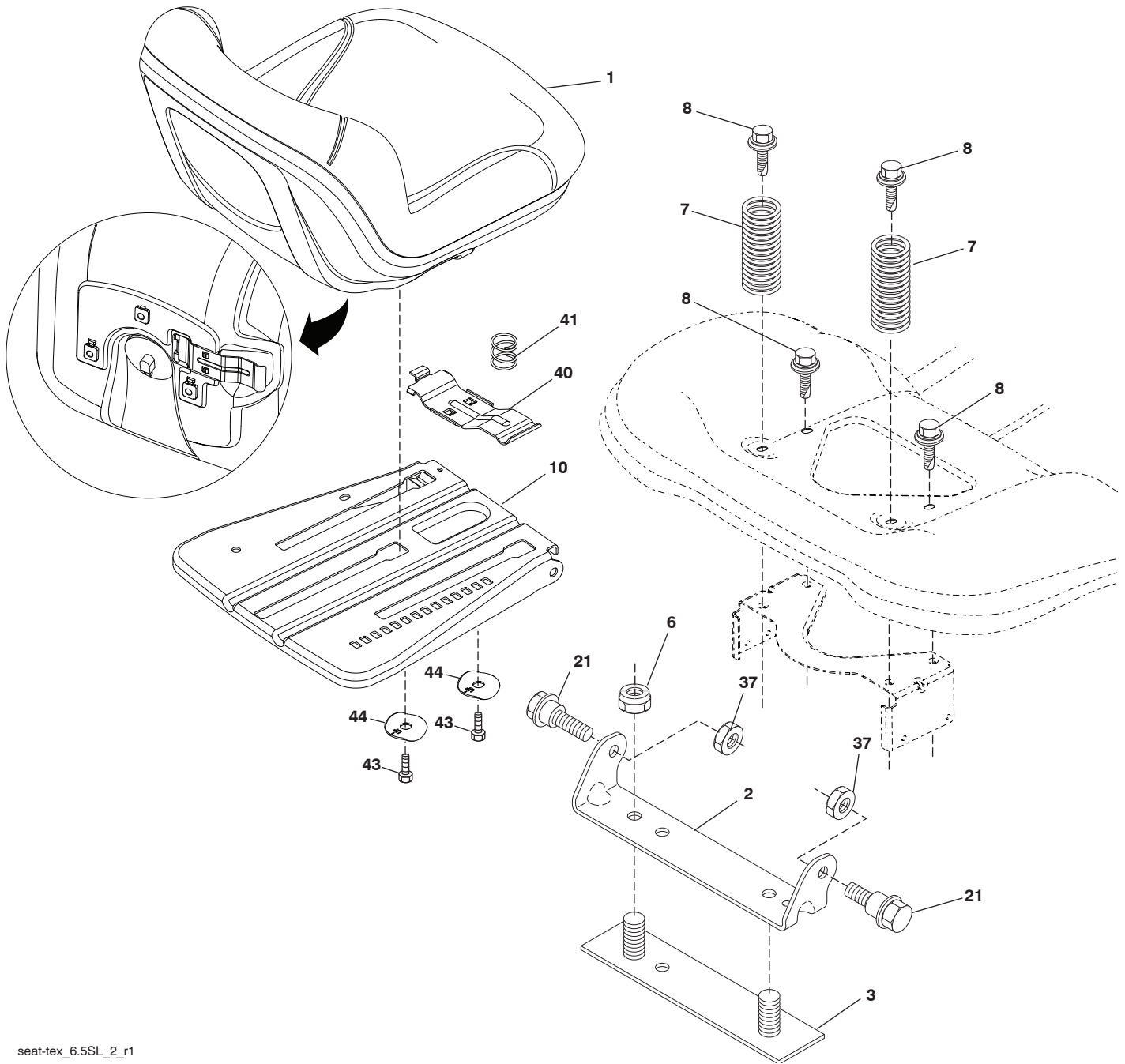

seat-tex_6.5SL_2_r1

KEY NO.	PART NO.	DESCRIPTION
1	532 40 66-25	Seat
2	532 18 01-66	Bracket Pivot Fender
3	532 14 06-75	Strap Asm. Fender
6	873 80 06-00	Nut, Lock w/Ins. 3/8-16 unc
7	589 48 35-01	Spring, Seat Cprsn.
8	532 17 18-77	Bolt 5/16-18 unc x 3/4 w/Sems.
10	587 23 20-02	Pan, Seat
21	587 90 78-01	Bolt, Shoulder 5/16-18 x 5/8

KEY NO.	PART NO.	DESCRIPTION
37	873 80 05-00	Nut, Lock 5/16-18 unc
40	532 19 76-61	Handle
41	532 19 82-00	Spring
43	874 76 06-12	Bolt 3/8-16 unc x 3/4
44	501 05 18-01	Washer Winged

NOTE: All component dimensions given in U.S. inches
1 inch = 25.4 mm

TRACTOR - - MODEL NO. LT2320 CMA2 (96051008404), PRODUCT NO. 960 51 00-84
BAGGER **46**

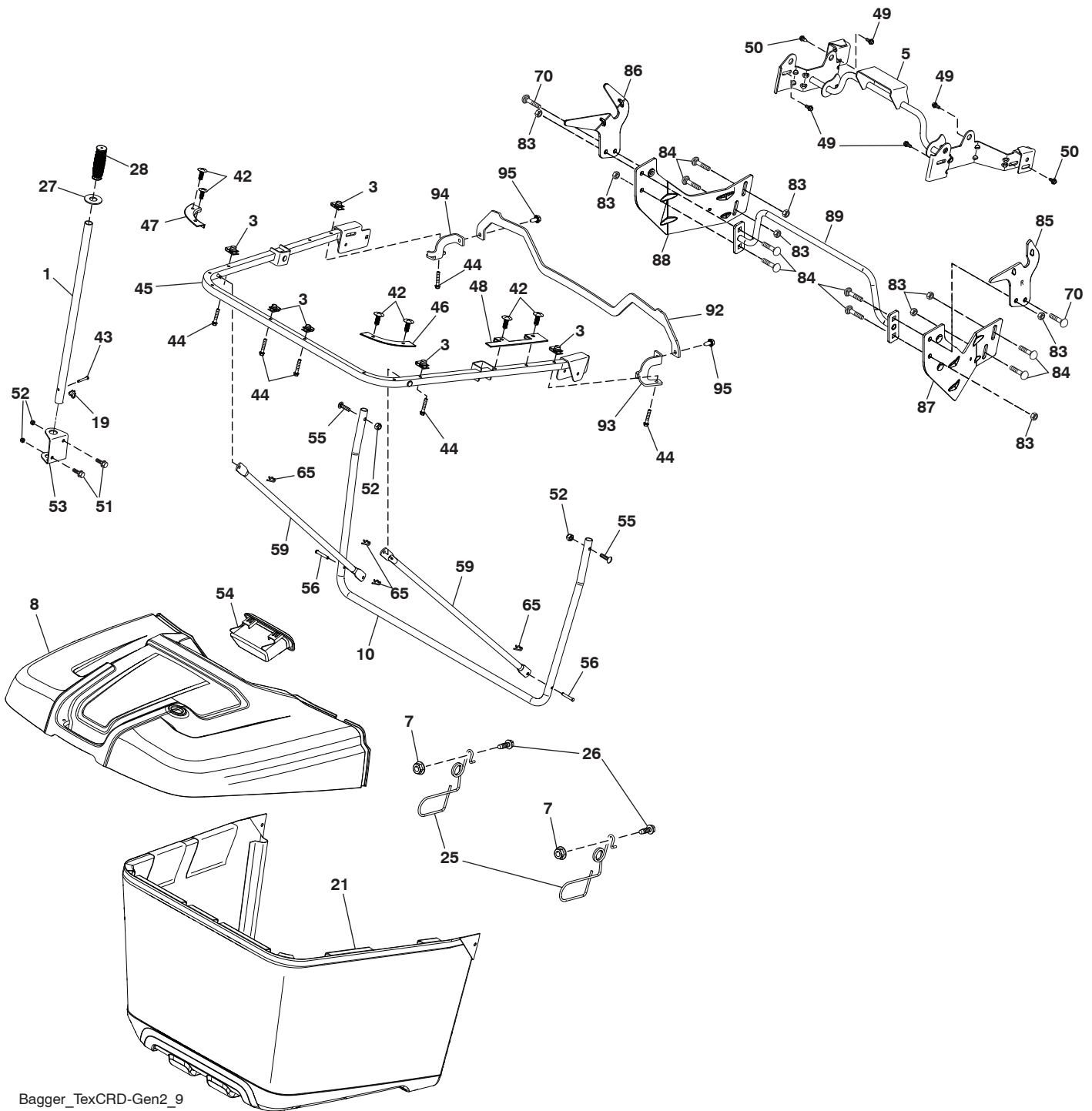

Bagger_TexCRD-Gen2_9

**TRACTOR - - MODEL NO. LT2320 CMA2 (96051008404), PRODUCT NO. 960 51 00-84
BAGGER 46**

KEY NO.	PART NO.	DESCRIPTION
1	532 42 86-10	Tube Handle Bagger
3	532 17 48-14	Nut Push
5	532 44 37-62	Frame Asm Top Bagger
7	873 90 04-00	Nut Hex Flange 1/4-20 unc
8	532 44 78-28	Cover Bagger
10	532 44 37-55	Frame Front
19	532 19 42-08	Cotter Pin 5/16 Bow Tie
21	581 33 71-02	Bag Asm
25	532 44 55-28	Latch Bagger
26	817 49 04-12	Screw Hexwsh Thdrol 1 14-20 x 3/4
27	532 44 55-29	Grommet Rubber
28	532 16 57-87	Grip Handle Black
42	532 44 04-28	Christmas Tree Clip
43	532 12 68-75	Clevis Pin
44	532 19 96-87	Bolt 1/4-20 1.50
45	532 44 37-54	Upper U Frame Weldment
46	532 44 55-41	Bagger Corner Close-Out RH
47	532 44 40-79	Bagger Corner Close-Out LH
48	532 44 40-80	Top Bagger Side Close-Out
49	532 17 18-73	Bolt Shoulder 5/16-18 TT
50	532 17 18-77	Bolt 5/16-18 unc x 3/4 W/SEMS
51	872 05 05-06	Bolt 5/16-18 Carriage x 3/4
52	873 80 05-00	Nut Lock HX W/INS 5/16-18 UNC
53	532 44 41-95	Bracket Dump Handle
54	532 44 75-43	Bagger TOP Front Handle
55	539 10 29-33	Bolt 5/16-18 x 1-1/2 Gr. ZD
56	532 42 03-06	Pin Clevis .1830D x 1.26 long
59	532 44 47-63	Bagger Spread Tube
65	532 12 47-88	Retainer Spring
70	817 00 06-12	Bolt 3/8-16 x 3/4
83	873 80 06-00	Nut Lock Hex w/Ins 3/8-16
84	872 11 06-08	Bolt RDHD SQNK 3/8-16 x 1 Gr. 5
85	581 31 44-02	Bracket RH Pivot
86	581 31 43-02	Bracket LH Pivot
87	581 31 48-02	Bracket RH
88	581 31 47-02	Bracket LH
89	581 31 51-04	Weldment Offset Strut
92	586 05 23-02	Bracket Top Support
93	586 05 24-02	Bracket Support RH
94	586 05 25-02	Bracket Support LH
95	817 00 05-12	Screw 5/16-18 x 3/4

NOTE: All component dimensions given in U.S. inches
1 inch = 25.4 mm

