

ILLUSTRATED PARTS LIST

MFG. ID NO. 96043029800

CUSTOMER CATALOG NO. LTH17538

PRODUCT NO. 960 43 02-98

**TRACTOR - - MODEL NO. LTH17538 (96043029800), PRODUCT NO. 960 43 02-98
DECALS 27**

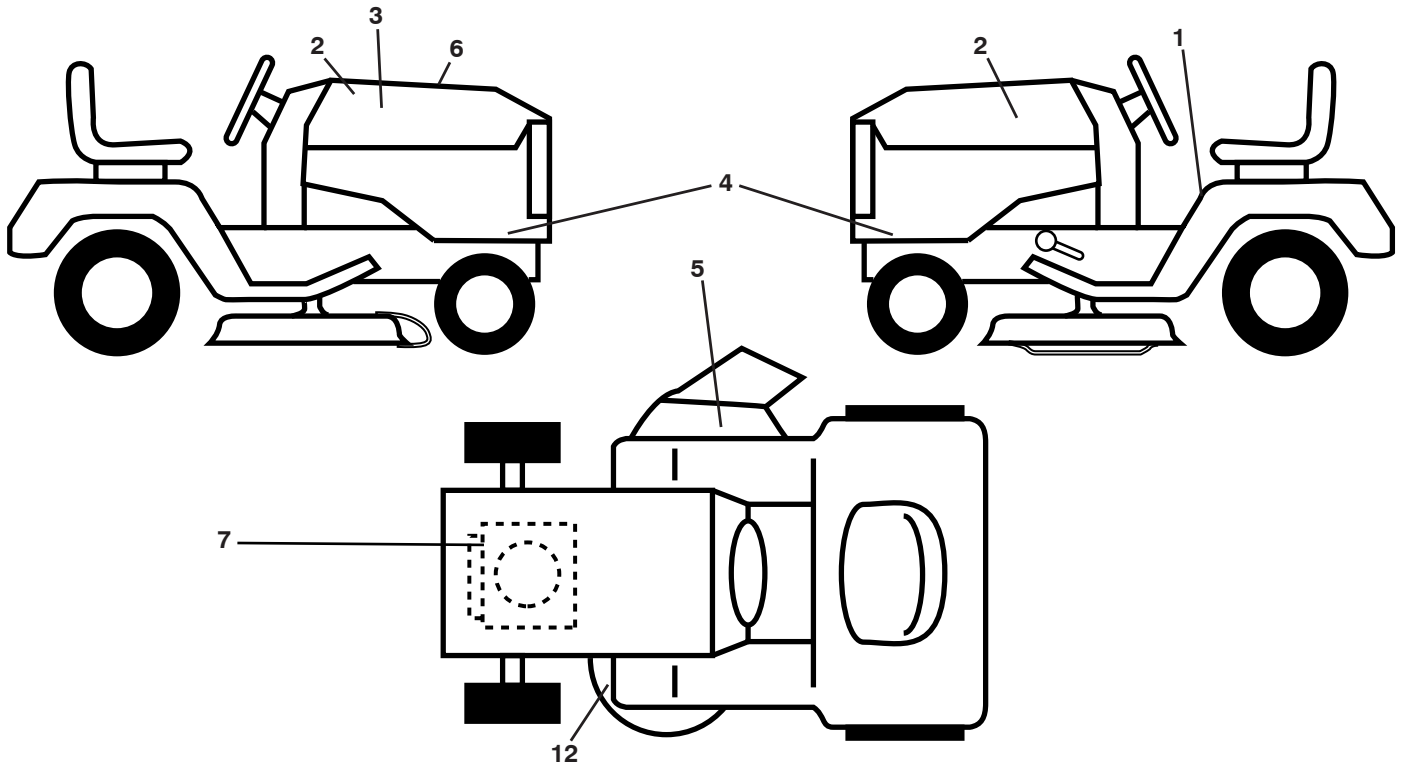

KEY NO.	PART NO.	DESCRIPTION
1	581 57 89-01	Decal, Fender Warn./Instructions
2	501 13 14-01	Decal, Husq
3	596 87 33-01	Decal, Replacement
4	596 88 30-01	Decal, Side Panel
5	584 90 46-01	Decal, Deflect. Warning
6	532 42 38-29	Decal, Warning
7	585 55 59-01	Decal, BS17
12	581 58 00-03	Decal, Mower V-Belt Schematic

KEY NO.	PART NO.	DESCRIPTION
--	581 72 48-01	Decal, Bypass
--	532 43 96-81	Pad, Footrest, LH
--	532 43 99-66	Pad, Footrest, RH
--	114 09 78-49	Manual, Operator's (English/Spanish)
--	114 09 79-49	Manual, Parts (English/Spanish)
--	587 71 00-26	Manual, Quick Start Guide (English/Spanish)

WHEELS AND TIRES

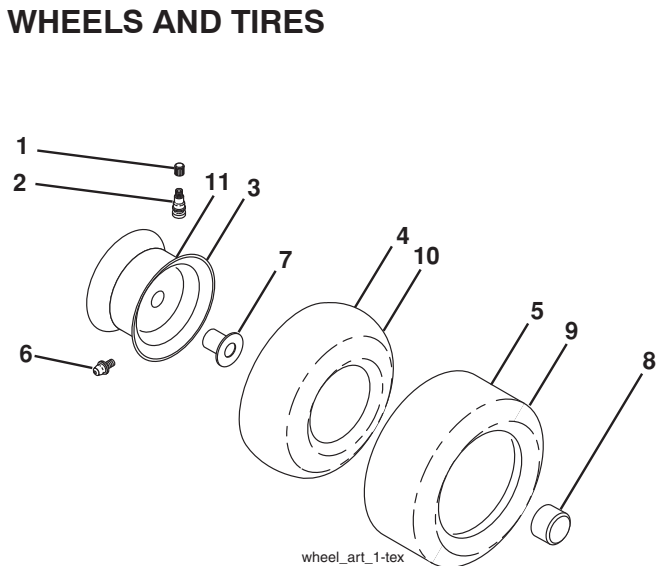

KEY PART NO.	PART NO.	DESCRIPTION
1	532 05 91-92	Cap Valve Tire
2	532 06 51-39	Stem Valve
3	532 13 83-36	Rim Asm 6" Front
4	532 05 99-04	Tube Front (Service Item Only)
5	532 10 62-22	Tire Front 15 x 6-6
6	532 00 02-78	Fitting Grease (Front Wheel Only)
7	532 00 90-40	Bearing Flange (Front Wheel Only)
8	532 17 50-39	Cap Axle Blk 1 50 x 1 00
9	532 13 84-68	Tire Rear 20 x 8-8
10	532 00 71-52	Tube Rear (Service Item Only)
11	532 13 83-37	Rim Asm 8" Rear
--	532 14 43-34	Sealant, Tire (10 oz. Tube)

NOTE: All component dimensions given in U.S. inches
1 inch = 25.4 mm

TRACTOR - - MODEL NO. LTH17538 (96043029800), PRODUCT NO. 960 43 02-98

SCHEMATIC 38

SCH11

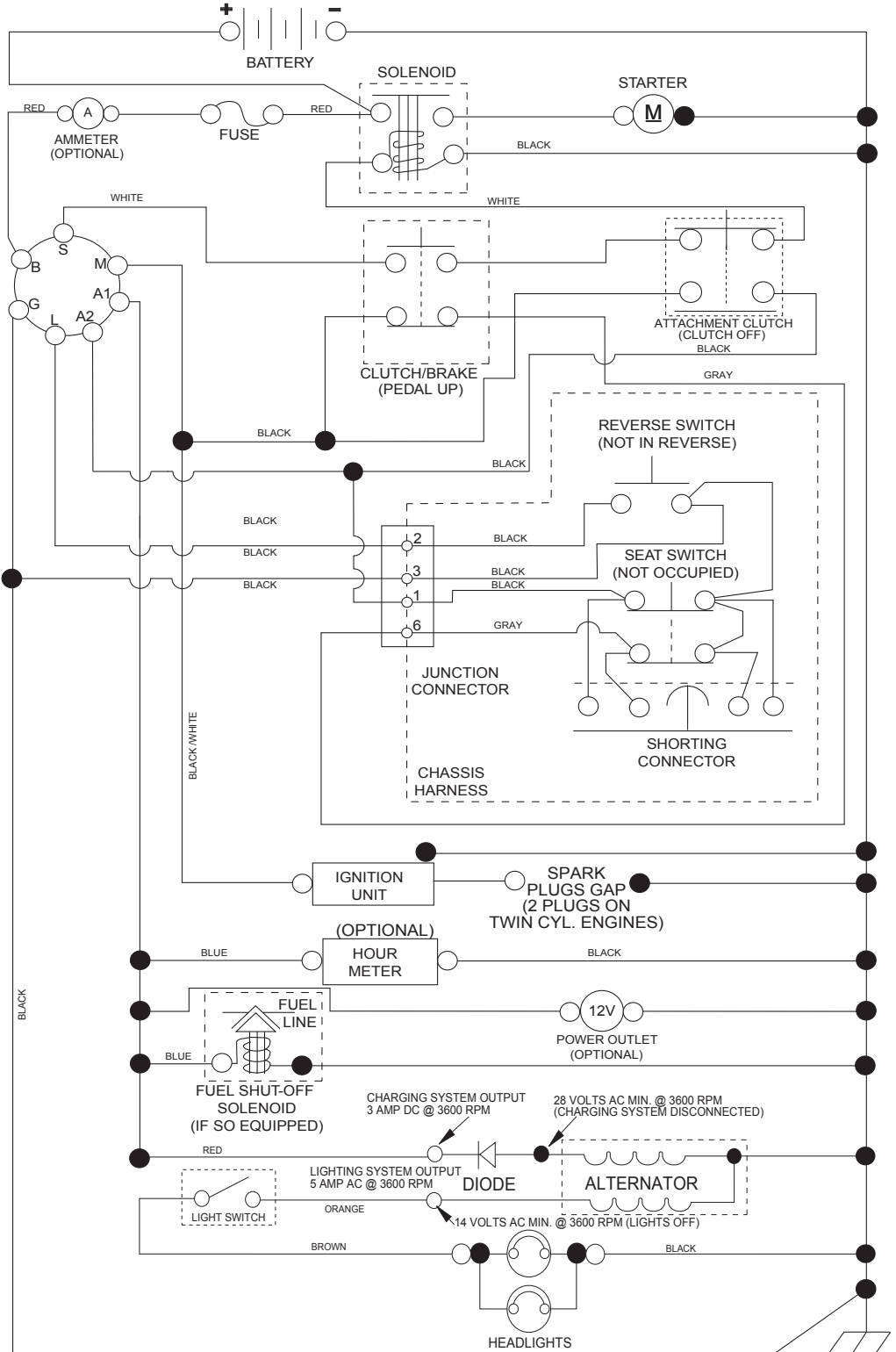

NOTE
YOUR TRACTOR IS EQUIPPED WITH A SPECIAL ALTERNATOR SYSTEM. THE LIGHTS ARE NOT CONNECTED TO THE BATTERY, BUT HAVE THEIR OWN ELECTRICAL SOURCE. BECAUSE OF THIS, THE BRIGHTNESS OF THE LIGHTS WILL CHANGE WITH ENGINE SPEED. AT IDLE THE LIGHTS WILL DIM. AS THE ENGINE IS SPEEDED UP, THE LIGHTS WILL BECOME THEIR BRIGHTEST.

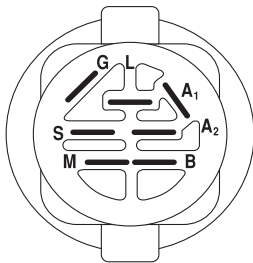

IGNITION SWITCH

POSITION	CIRCUIT "MAKE"
OFF	M+G+A1
RUN/OVERRIDE	B+A1
RUN	B+A1 L+A2
START	B + S + A1

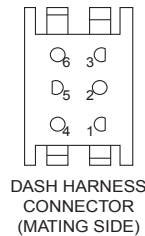
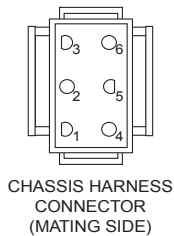

WIRING INSULATED CLIPS
NOTE: IF WIRING INSULATED CLIPS WERE REMOVED FOR SERVICING OF UNIT, THEY SHOULD BE RE-INSTALLED TO PROPERLY SECURE YOUR WIRING.

NON-REMOVABLE CONNECTIONS
REMOVABLE CONNECTIONS

TRACTOR - - MODEL NO. LTH17538 (96043029800), PRODUCT NO. 960 43 02-98
ELECTRICAL 32

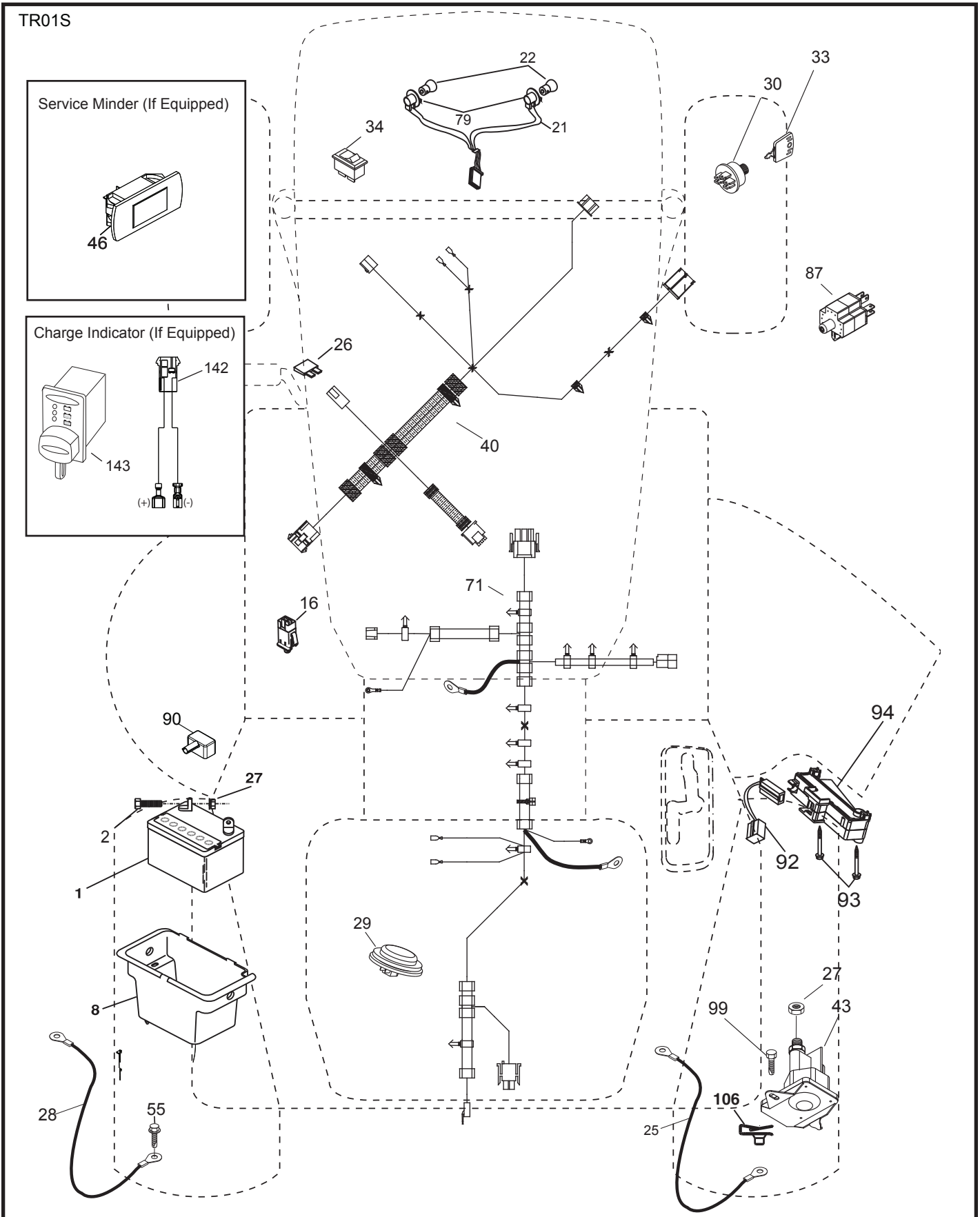

**TRACTOR - - MODEL NO. LTH17538 (96043029800), PRODUCT NO. 960 43 02-98
ELECTRICAL 32**

KEY NO.	PART NO.	DESCRIPTION
1	532 16 34-65	Battery
2	874 76 04-12	Bolt Hex Head 1/4-20 x 3/4
8	532 19 32-28	Box Battery
16	532 17 61-38	Switch Interlock Push-In
21	532 40 02-52	Harness Socket Light w/4152J
22	532 00 41-52	Bulb Light
25	581 49 80-01	Cable Starter
26	532 17 51-58	Fuse
27	596 13 36-01	Locknut Keps Hex 1/4-20 unc
28	532 42 16-86	Cable, Ground
29	532 40 15-45	Switch, Seat
30	532 19 33-50	Switch, Ign
33	532 41 19-33	Key/Chain
34	532 11 07-12	Switch Light/Reset
40	581 02 31-01	Harness Ign. Dash
43	582 04 28-02	Solenoid
55	817 06 05-12	Screw Thdrol 5/16-18 x 3/4
71	501 13 37-01	Harness Chassis
79	532 17 52-42	Socket Asm Bulb Twistlock
87	532 19 78-02	Switch Interlock Clutch Cable
90	532 43 53-95	Cover, Terminal Battery
92	532 19 66-15	Harness Pigtail Console
93	596 03 96-01	Bolt, Hex, 10-14 x 2-1/8
94	532 19 18-34	Module Reverse ROS
99	817 67 04-12	Screw
106	532 17 48-14	Pal nut

NOTE: All component dimensions given in U.S. inches
1 inch = 25.4 mm

**TRACTOR - - MODEL NO. LTH17538 (96043029800), PRODUCT NO. 960 43 02-98
CHASSIS AND ENCLOSURES 39**

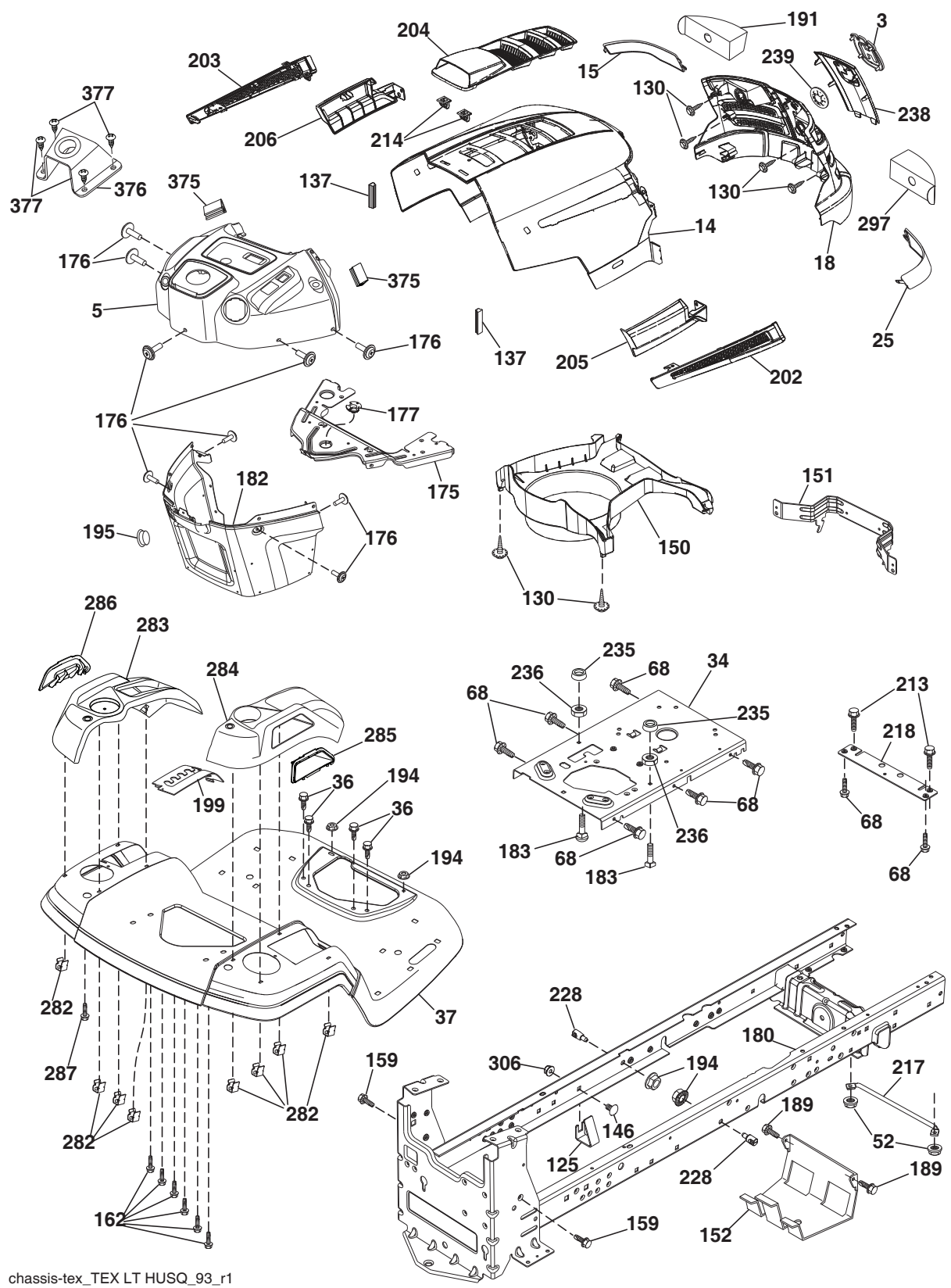

chassis-tex_TEX LT HUSQ_93_r1

**TRACTOR - - MODEL NO. LTH17538 (96043029800), PRODUCT NO. 960 43 02-98
CHASSIS AND ENCLOSURES 39**

KEY NO.	PART NO.	DESCRIPTION	KEY NO.	PART NO.	DESCRIPTION
3	581 05 63-01	Logo	202	532 44 13-42	Vent, Side Hood RH
5	532 43 89-64	Subasm, Dash, Upper, Hus, LT .498	203	532 44 13-43	Vent, Side Hood LH
14	532 44 12-67	Hood	204	532 44 13-75	Vent, Top Hood
15	532 44 14-28	Lens LH	205	532 44 13-44	Skirt, Side, RH
18	532 43 94-21	Grille Asm.	206	532 44 13-45	Skirt, Side, LH
25	532 44 14-27	Lens RH	213	596 03 07-01	Bolt, Hex, HD 5/16-18 unc x 3/4
34	580 91 08-01	Plate Engine	214	532 19 91-45	Clip, Retainer
36	817 06 05-12	Screw 5/16-18 x 3/4	217	532 40 91-67	Rod, Pivot, Hood
37	532 44 12-66	Fender	218	532 19 63-95	X-Piece Hood Stop
52	596 04 05-01	Nut, Lock Hex, PRVL 5/16-18	228	532 19 51-61	Stud, Fastener
68	596 03 07-01	Screw Hexagon 5/16-18 x 1/2	235	596 56 42-01	Spacer, Fender, Clr, Zn
125	581 68 48-01	Fuel Line Clip	236	873 93 05-00	Nut, Lock 5/16-18 unc
130	596 32 17-01	Screw #10 x 0.750 BOS Thread	238	532 44 13-74	Trim
137	532 40 75-90	Bumper Dash	239	532 40 48-83	Clip, Tinnerman
146	581 85 79-01	Bolt 3/8-16 x 5/8 unc	282	532 41 41-10	Clip, Retainer
150	532 40 66-62	Air Duct	283	532 44 20-39	Console, Asm LH
151	532 40 78-07	Bracket Pivot	284	532 44 41-64	Console, RH
152	532 19 95-35	Shield Browning	285	532 41 63-15	Console, Insert RH
159	817 00 06-12	Screw Hexwash Thor 3/8-16 x 3/4	286	532 41 63-17	Console, Insert LH
162	596 13 41-01	Screw, Hex, Tap 1/4-15 x 1/2	287	817 60 04-06	Screw, Hex, Washhead 1/4-20 x 3/8
175	532 19 94-72	Crossmember Plate	297	532 40 66-65	Insert, Reflective, LH
176	532 40 07-76	Screw 10-24 x 5/8	306	873 90 06-00	Nut, Lock, Flg 3/8-16 unc
177	532 19 52-28	Bushing Steering	375	586 90 82-01	Dash, Clip-On, Bumper
180	532 19 54-57	Chassis	376	589 45 87-01	Mount, Asm, Husit, Upper, Strng
182	532 40 71-76	Dash Lower	377	589 45 53-01	Screw 10 x 1/2 ZN PL Phil Pan AB
183	595 30 57-01	Screw Hexagon 5/16-18 x 1-1/4			
189	817 00 05-12	Screw			
191	532 41 65-01	Insert Reflective RH			
194	596 13 57-01	Nut Lock PRVL, Torq 5/16-18 x .68			
195	532 43 99-76	Plug Dash			
199	532 41 34-85	Plate Deck Lift			

NOTE: All component dimensions given in U.S. inches
1 inch = 25.4 mm

TRACTOR - - MODEL NO. LTH17538 (96043029800), PRODUCT NO. 960 43 02-98
DRIVE **40**

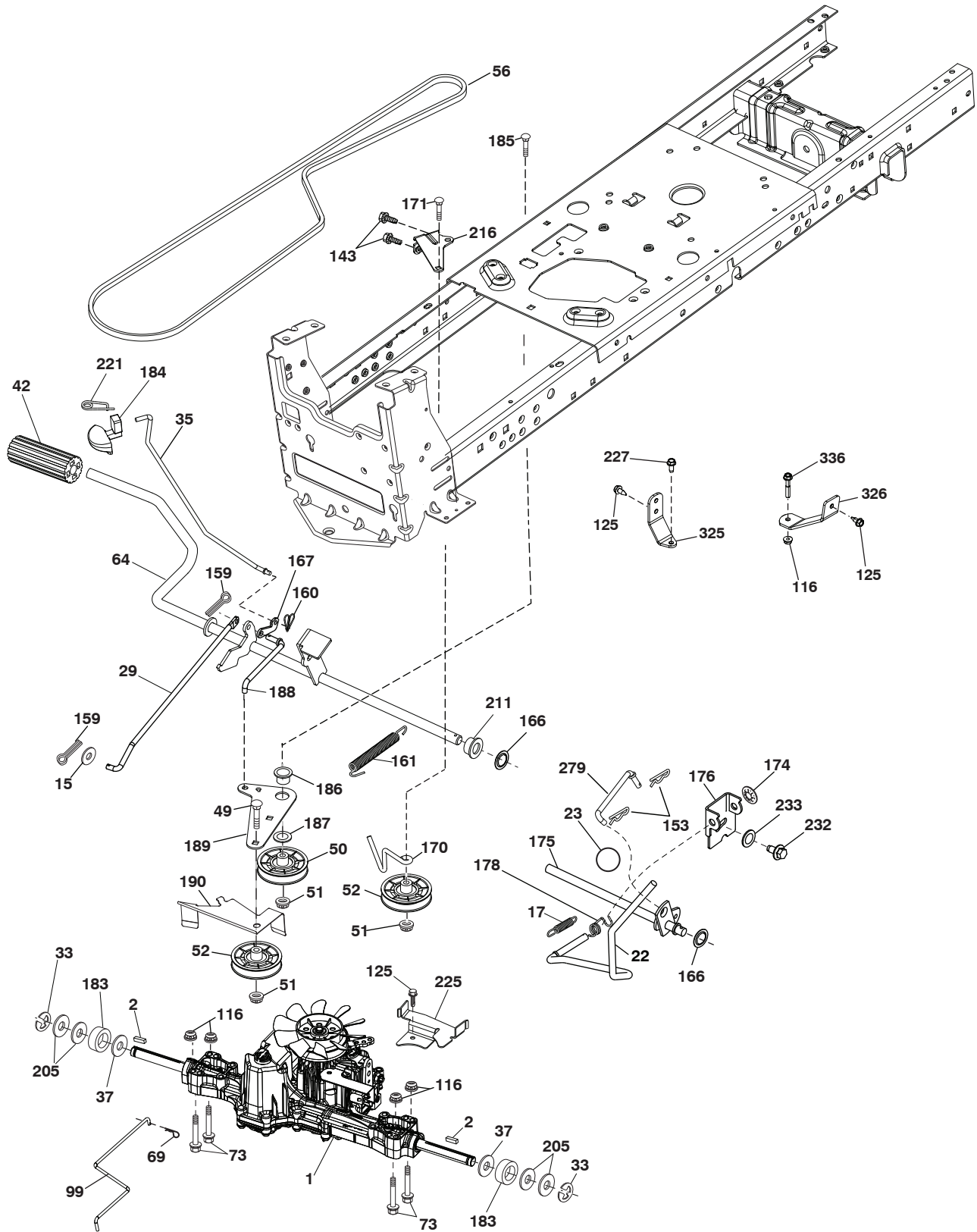

drive-tex_K46_fender_52

**TRACTOR - - MODEL NO. LTH17538 (96043029800), PRODUCT NO. 960 43 02-98
DRIVE **40****

KEY NO.	PART NO.	DESCRIPTION	KEY NO.	PART NO.	DESCRIPTION
1	---	Transaxle, Tufftorq K46BA (448348) (Order parts from transaxle manufacturer.)	170	532 19 43-22	Keeper Belt Centerspan
2	532 12 35-83	Key Square	171	596 13 63-01	Bolt Cup Head 3/8-16 x 2
15	819 13 13-16	Washer 13/32 x 13/16 x 16 Ga.	174	532 19 72-89	Nut Push
17	532 41 36-78	Spring, Brake	175	532 40 62-08	Shaft Asm Shift
22	532 19 76-60	Rod Shift	176	532 19 62-14	Arm Clevis Rod Shift
23	532 14 08-45	Knob	178	532 19 74-56	Spring Shift
29	532 40 38-06	Rod, Brake	183	532 13 70-57	Spacer Axle
33	812 00 00-01	Ring E	184	532 41 14-84	Handle Parking Brake
35	590 52 75-02	Rod, Brake, Park	185	872 11 06-22	Bolt
37	532 18 89-67	Washer Harden .793 x 1.637 x 060	186	532 19 43-21	Spacer Retainer
42	532 00 88-83	Cover, Pedal, BLK, Round	187	596 13 55-01	Washer 13/32 x 2 Clear, Zinc
49	596 13 62-01	Bolt, Cup, Head 3/8-16 x 3/4	188	582 21 70-01	Link Clutch Ground Drive, Long
50	532 19 43-27	Pulley Idler Flat	189	532 19 43-17	Bellcrank Ground Drive
51	873 90 06-00	Lock Nut 3/8-16	190	532 19 43-18	Keeper Bellcrank Ground Drive
52	532 19 43-26	Idler V-Groove Offset	205	532 12 17-48	Washer 25/32 x 1-5/8 x 16 Ga.
56	592 85 52-01	Belt, Drive, Tex, K46	211	532 19 62-12	Bushing Shaft
64	532 19 62-00	Shaft Asm. Pedal Brake Control	216	532 19 61-31	Bracket Pulley Idler
69	532 42 33-03	Hairpin .059 x 1.125	221	532 40 31-87	Retainer Spring Clip Handle
73	596 13 65-01	Bolt Hex, Head, 5/16-18 x 1-1/2	225	532 40 33-19	Keeper Belt
99	582 40 45-01	Rod Spring Bypass	227	596 13 59-01	BoltHex 5/16-18 x 3/4 CLR, ZNC
116	596 13 57-01	Nut Lock PRVL, Torq 5/16-18 x .68	232	596 23 86-01	Bolt Hex 7/16-14 x 1 CLR, ZNC
125	817 00 05-12	Screw 5/16-18 x 3/4	233	596 13 52-01	Washer, Lock, 0.47 x 1, Clear, Zn
143	596 03 07-01	Screw Hexagon 5/16-18 x 1/2	279	532 40 62-07	Link Shift
153	532 00 44-97	Retainer Spring 1", Zinc/Cad	325	585 66 85-02	Bracket, Torque Strap LH
159	596 02 95-01	Pin Cotter 1/8 Dia. x 3/4	326	585 67 08-02	Bracket, Torque Strap RH
160	596 02 94-01	Retainer Clip "M-Shape"	336	587 25 96-02	Bolt 5/16-18 x 1-3/4
161	532 10 57-09	Spring, Return, Clutch			
166	532 42 91-64	Nut Push .625			
167	532 40 52-57	Latch Brake Parking			

NOTE: All component dimensions given in U.S. inches
1 inch = 25.4 mm

**TRACTOR - - MODEL NO. LTH17538 (96043029800), PRODUCT NO. 960 43 02-98
ENGINE 24**

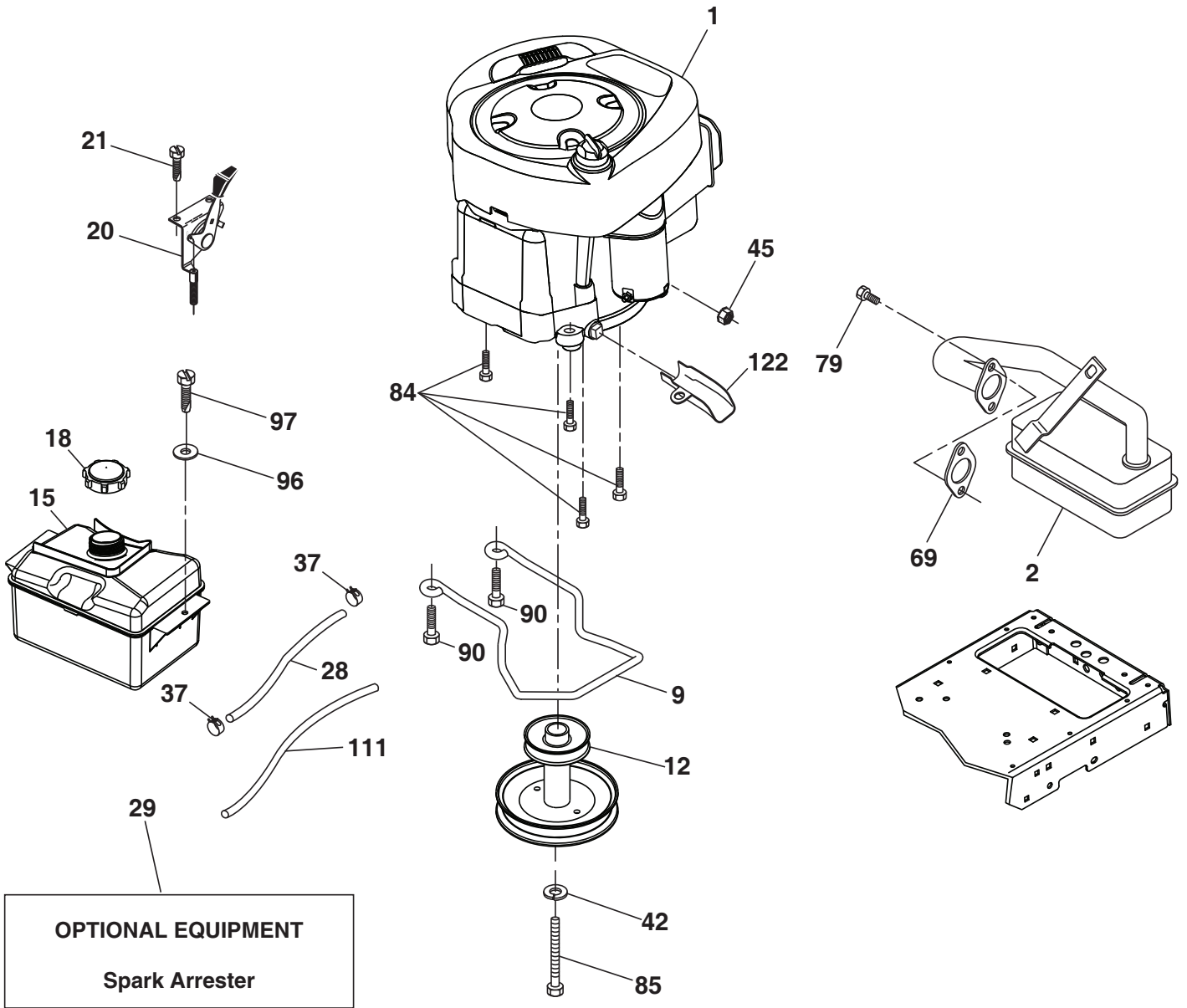

OPTIONAL EQUIPMENT
Spark Arrester

engine-tex_BS_114

**TRACTOR - - MODEL NO. LTH17538 (96043029800), PRODUCT NO. 960 43 02-98
ENGINE 24**

KEY NO.	PART NO.	DESCRIPTION
1	---	Engine B&S Model No. 3IR977-0014-G1 (585822501)
2	532 13 73-52	Muffler
9	501 83 26-02	Keeper Belt Engine
12	586 47 85-01	Pulley Engine
15	532 43 30-10	Tank Fuel Asm.
18	581 17 61-01	Cap Fuel
20	532 18 38-97	Control Throttle/Choke
21	596 32 17-01	Screw #10 x 0.750 BOS Thread
28	532 40 11-37	Fuel Line
29	532 13 71-80	Spark Arrester Kit
37	532 12 34-87	Clamp Hose
42	596 23 89-01	Washer 7/16 IN, CLR, ZN
45	596 13 36-01	Locknut Keps 1/4-20
69	532 16 52-91	Gasket
79	596 13 42-01	Screw Hex, Socket 5/16-18 x 3/4
84	817 06 06-20	Screw 3/8-16 x 1-1/4
85	501 60 65-01	Bolt Hex 7/16-20 x 4 Gr. 5 1.5
90	817 00 06-16	Screw 3/8-16 x 1
96	596 13 53-01	Washer, Plain 9/32 x 7/8 CLR, ZN
97	817 67 04-12	Screw 1/4-20 x 3/4
111	596 94 15-01	Tube, Purge, Fuel .1875"
122	532 42 19-22	Extension Drain Oil

NOTE: All component dimensions given in U.S. inches
1 inch = 25.4 mm

For engine service and replacement parts, call the toll free number for your engine manufacturer listed below:

Briggs & Stratton 1-800-233-3723

Engine Power Rating Information

The gross power rating for individual gas engine models is labeled in accordance with SAE (Society of Automotive Engineers) code J1940 (Small Engine Power & Torque Rating Procedure), and rating performance has been obtained and corrected in accordance with SAE J1995 (Revision 2002-05). Torque values are derived at 3060 RPM; horsepower values are derived at 3600 RPM. Actual gross engine power will be lower and is affected by, among other things, ambient operating conditions and engine-to-engine variability. Given both the wide array of products on which engines are placed and the variety of environmental issues applicable to operating the equipment, the gas engine will not develop the rated gross power when used in a given piece of power equipment (actual "on-site" or net power). This difference is due to a variety of factors including, but not limited to, accessories (air cleaner, exhaust, charging, cooling, carburetor, fuel pump, etc.), application limitations, ambient operating conditions (temperature, humidity, altitude), and engine-to-engine variability. Due to manufacturing and capacity limitations, Briggs & Stratton may substitute an engine of higher rated power for this Series engine.

TRACTOR - - MODEL NO. LTH17538 (96043029800), PRODUCT NO. 960 43 02-98
STEERING ASSEMBLY **41**

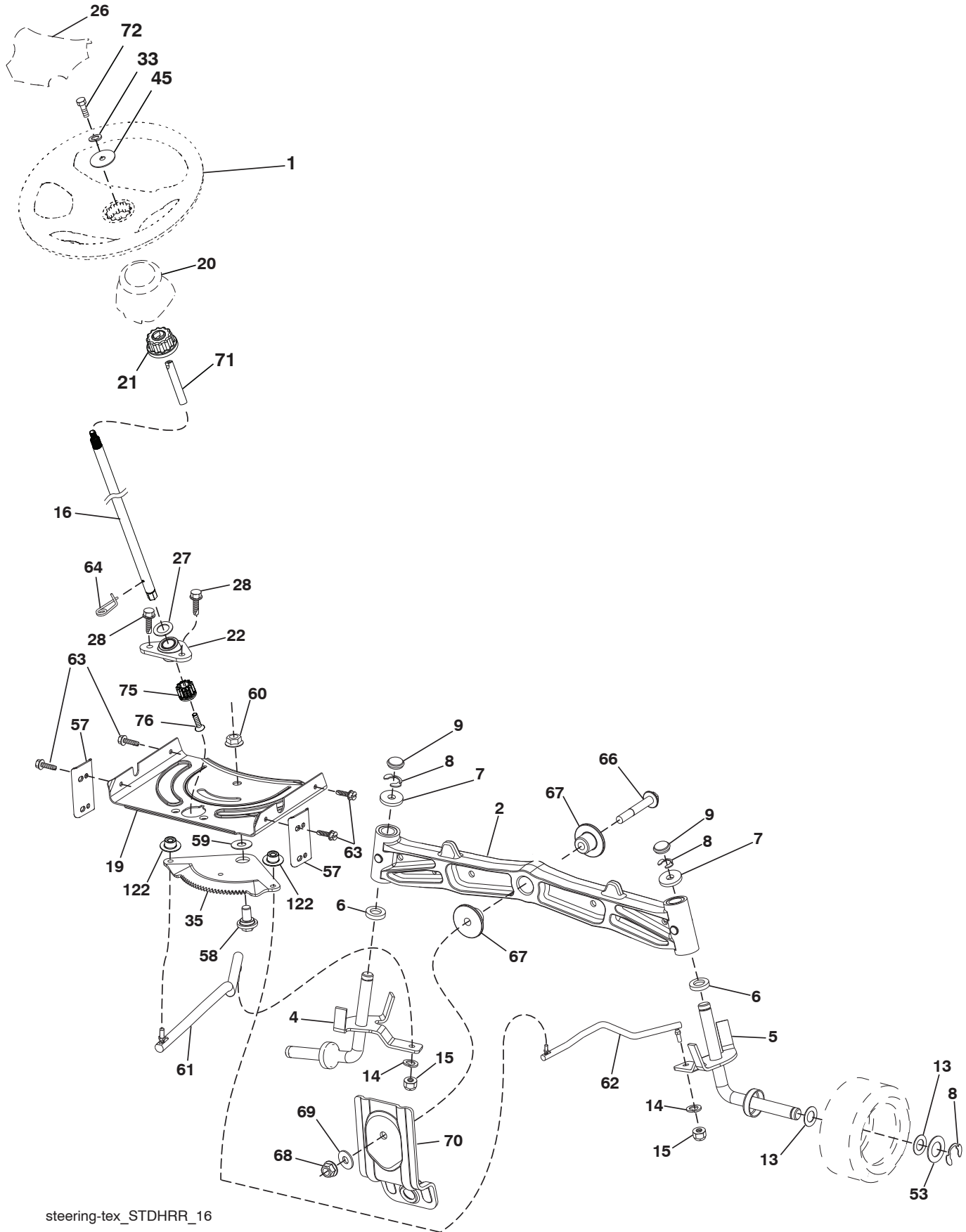

steering-tex_STDHRR_16

**TRACTOR - - MODEL NO. LTH17538 (96043029800), PRODUCT NO. 960 43 02-98
STEERING ASSEMBLY 41**

KEY NO.	PART NO.	DESCRIPTION
1	532 43 97-40	Wheel, Steering
2	532 19 59-68	Axle Asm., Front
4	532 40 30-87	Spindle Asm., LH
5	532 40 30-88	Spindle Asm., RH
6	532 00 62-66	Washer, Thrust .75 x 1.230
7	532 12 17-48	Washer 25/32 x 1-5/8 x 16 Ga.
8	812 00 00-29	Ring, Klip #T5304-75
9	532 12 12-32	Cap, Spindle
13	532 12 17-49	Washer SLW ZD 3/8
14	596 23 87-01	Washer, Spring, Lock .381ID x .680
15	873 54 06-00	Nut, Crown Lock 3/8-24 unf
16	585 86 92-02	Steering Shaft
19	532 19 47-29	Plate Steering
20	532 44 14-25	Boot Steering
21	532 18 67-37	Adapter, Wheel Steering
22	585 02 98-02	Bearing Shaft
26	532 43 97-43	Insert, Wheel Steering
27	596 93 34-01	Washer, Plain
28	817 00 06-12	Screw 3/8-16 x 3/4
33	539 99 01-87	Lockwasher 5/16
35	532 19 47-32	Gear, Sector Plate
45	819 11 38-12	Washer 11/32 ID x 2 3/8 OD x 12 Ga.
53	532 18 89-67	Washer Hardened .793 x 1.637 x .060
57	532 40 74-65	Bracket Upstop
58	532 19 47-47	Bolt Shoulder Sector Pivot CFM
59	532 19 47-48	Washer Thrust Sector Steering
60	873 97 10-00	Nut Flange Lock 5/8-11
61	597 07 02-02	Draglink, LH, Adj, Std, Clr, Zn
62	597 07 03-02	Draglink, RH, Adj, Std, Clr, Zn
63	817 00 05-12	Screw 5/16-18 x 3/4
64	532 19 98-49	Retainer Clip Spring Steering
66	871 02 07-48	Bolt Hex Fghd 7/16-14 x 3 Serr
67	532 19 47-37	Bushing PM Front Axle
68	873 90 07-00	Nut Lock Flange 7/16-14 Gr. 5
69	532 19 91-62	Washer 1.5 x .505 x .118
70	585 33 88-01	Bracket Deck Susp. Front
71	532 19 07-52	Shaft Exten. Strg.
72	596 03 97-01	Bolt Hex, Head 5/16-18 unc x 4" Gr. 5
75	580 68 37-01	Pinion
76	580 68 36-01	Screw Head Sock
122	532 44 49-62	Cap Gear

NOTE: All component dimensions given in U.S. inches
1 inch = 25.4 mm

TRACTOR - - MODEL NO. LTH17538 (96043029800), PRODUCT NO. 960 43 02-98
 MOWER DECK [44]

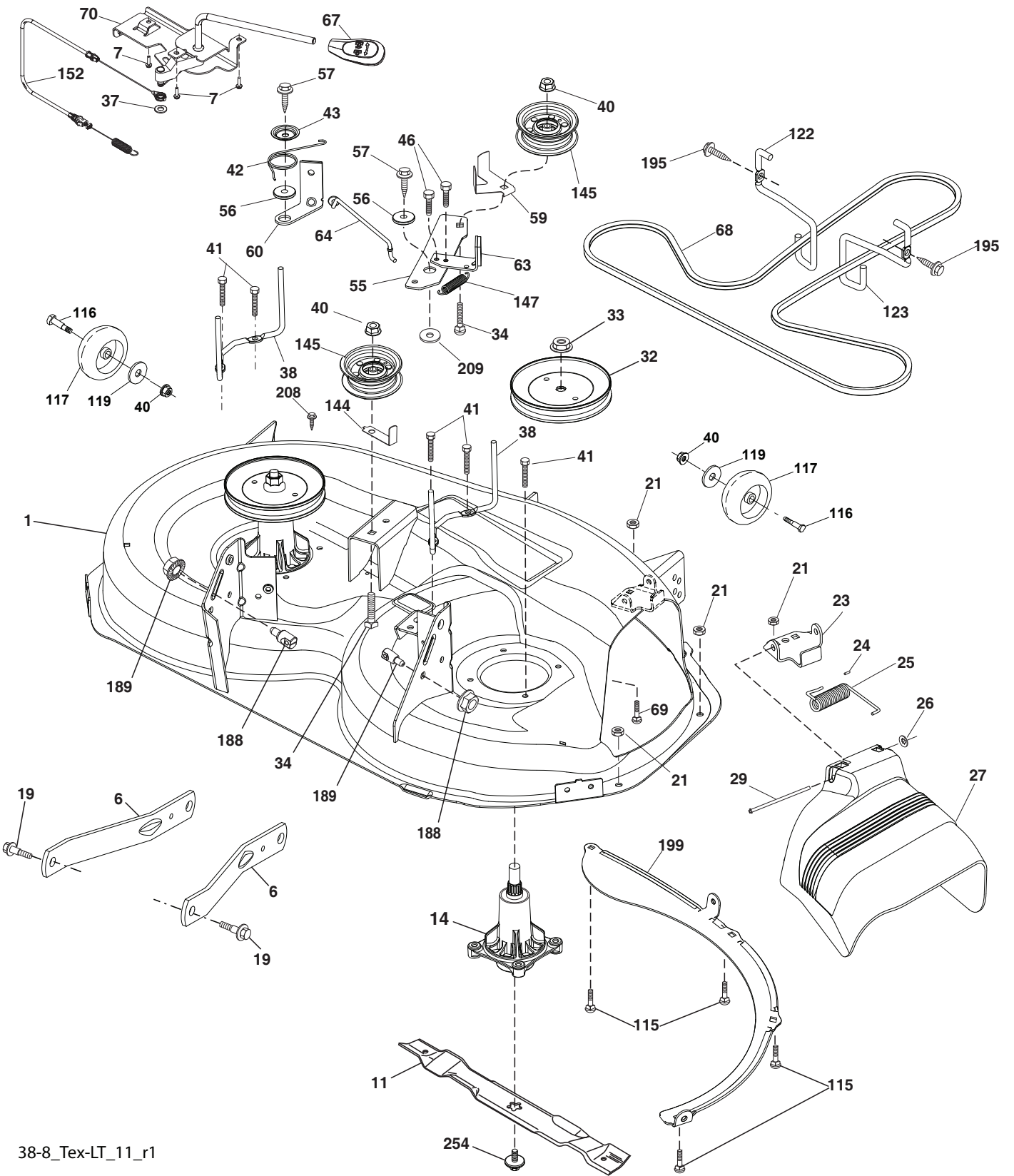

38-8_Tex-LT_11_r1

**TRACTOR - - MODEL NO. LTH17538 (96043029800), PRODUCT NO. 960 43 02-98
MOWER DECK 44**

KEY NO.	PART NO.	DESCRIPTION	KEY NO.	PART NO.	DESCRIPTION
1	592 93 88-01	Kit SVC Weldment	63	532 19 94-70	Arm Brake Mower RH
6	532 19 51-86	Arm Suspension	64	532 19 99-18	Link Brake
7	596 32 17-01	Screw #10 x 0.750 BOS Thread	67	532 40 30-12	Handle Clutch Cable
11	581 11 63-02	Blade 38"	68	532 40 83-81	V-Belt
14	587 81 97-01	Kit, Mandrel, Nongrease, Tall (Includes Mandrel and Bolts)	69	596 13 64-01	Bolt, Cup Head 5/16- x 5/8
19	532 19 65-39	Bolt, Shoulder	70	532 40 12-46	Clutch Asm Manual
21	596 04 05-01	Nut, Lock, Hex, PRVL 5/16-18	115	872 11 05-05	Bolt Carr. 5/16-18 x 5/8
23	532 19 25-57	Bracket, Deflector	116	596 43 44-02	Bolt, Shoulder 2.41 x 1.66 x .5" CLR, ZN
24	532 10 53-04	Cap, Sleeve	117	589 52 74-01	Wheel, Gauge
25	532 19 70-26	Spring, Torsion, Deflector	119	596 13 49-01	Washer, Plain 3/8 x 7/8
26	532 11 04-52	Nut, Push	122	532 19 72-58	Keeper Belt Engine LH
27	532 19 39-68	Shield, Deflector	123	532 19 72-59	Keeper Belt Engine RH
29	595 29 70-01	Rod, Hinge	144	532 19 34-14	Keeper Belt
32	532 19 97-89	Pulley, Mandrel	145	532 19 31-97	Pulley Idler
33	596 13 48-01	Nut, Hex 9/16-18 x 1.010	147	532 40 18-72	Spring Return
34	596 13 61-01	Bolt, Cup, Head 3/8-16 x 1-1/2	152	532 43 51-11	Manual Clutch Cable
37	596 56 53-01	Washer 3/8 x 0.08 IN, ST, CLR, ZN	188	532 19 51-61	Stud Fastener
38	532 19 95-41	Keeper Belt LH Mandrel	189	596 13 57-01	Nut Lock, PRVL, Torq, 5/16-18 x .68
40	873 90 06-00	Nut, Lock Flg. 3/8-16 unc	195	817 00 06-12	Screw 3/8-16 x 3/4
41	584 95 39-01	Bolt Hex Wshrhhd 3/16-18 x 1.19	199	532 40 00-95	Baffle Vortex
42	532 19 84-10	Spring Torsion Brake	208	817 67 06-08	Screw Thdrol 3/8-16 x 1/2
43	532 19 72-56	Spring Torsion Retainer	209	596 13 55-01	Washer 13/32 x 2 Clear, Zinc
46	532 13 77-29	Screw 1/4-20 x 5/8	254	584 30 93-01	Screw Sems 7/16-20 x 1 Hex Head
55	532 19 72-49	Arm, Idler	--	592 93 89-01	Replacement Mower, Complete
56	532 19 90-92	Spacer, Retainer			
57	817 00 06-16	Screw 3/8-16 x 1			
59	532 14 10-43	Guard, Tuv Idler			
60	532 19 94-71	Arm Brake Mower LH			

NOTE: All component dimensions given in U.S. inches
1 inch = 25.4 mm

TRACTOR - - MODEL NO. LTH17538 (96043029800), PRODUCT NO. 960 43 02-98
MOWER LIFT 45

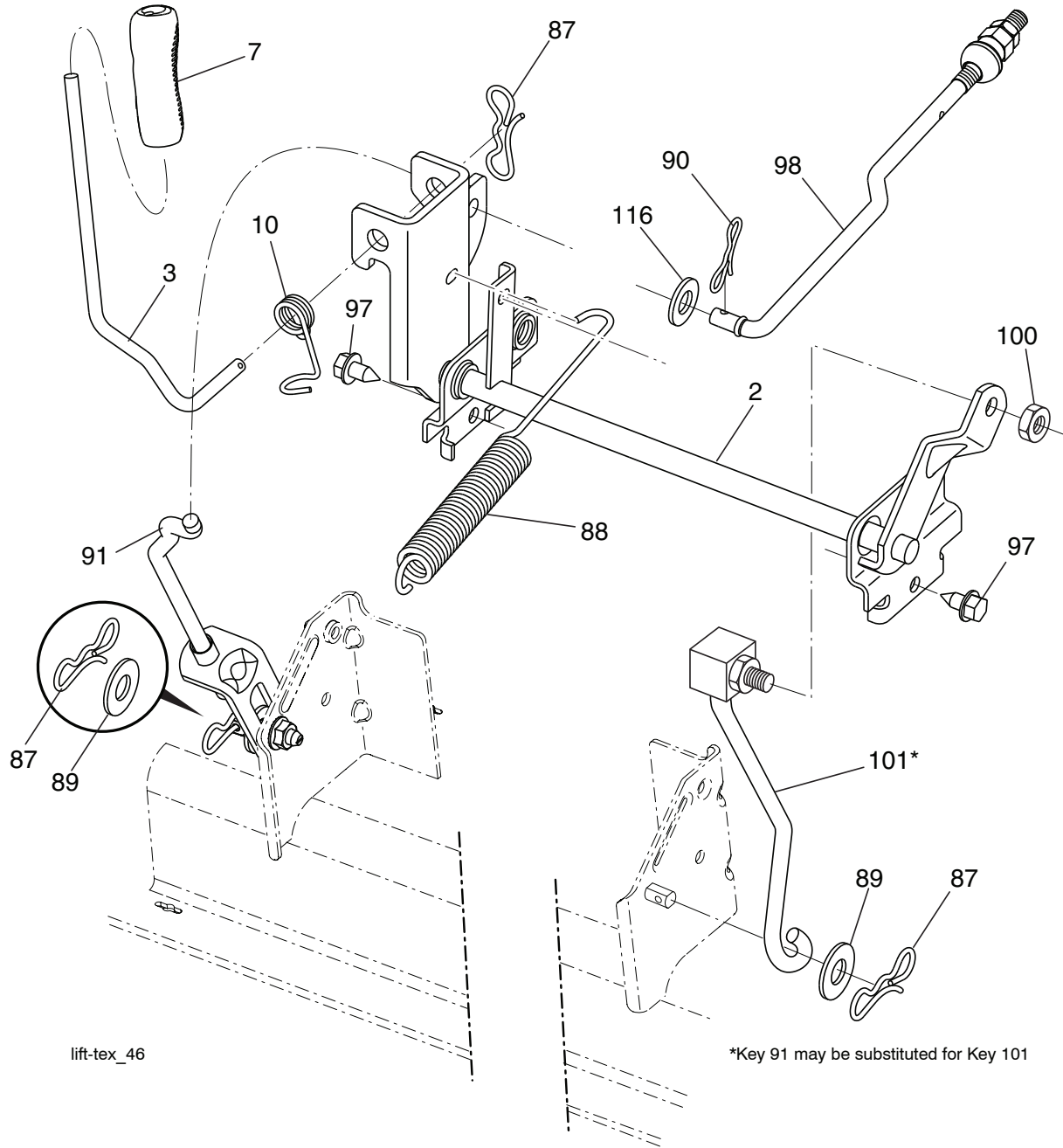

KEY NO.	PART NO.	DESCRIPTION
2	532 42 20-27	Shaft Asm., Lift
3	532 19 52-31	Lever Asm., Lift RH
7	580 96 23-01	Grip, Lever
10	532 19 63-14	Spring Torsion
87	532 19 42-09	Pin Cotter 7/16 Bow Tie Lock
88	532 41 07-10	Spring
89	819 19 19-12	Washer Clear Zinc
90	532 19 42-08	Pin Cotter 5/16 Bow Tie Lock
91	532 19 51-81	Link Asm Lift LH Rear

KEY NO.	PART NO.	DESCRIPTION
97	817 00 06-12	Screw Hex Wsh. THDR 3/8-16 x 3/4
98	532 19 52-70	Link Lift Susp. Front Mower
100	595 30 59-01	Nut, Hex, Locknut 3/8-16
101	532 40 70-03	Link Asm. Fixed
116	819 15 15-16	Washer 15/32 x 15/16 x 16 Ga.

NOTE: All component dimensions given in U.S. inches
 1 inch = 25.4 mm

**TRACTOR - - MODEL NO. LTH17538 (96043029800), PRODUCT NO. 960 43 02-98
SEAT ASSEMBLY 42**

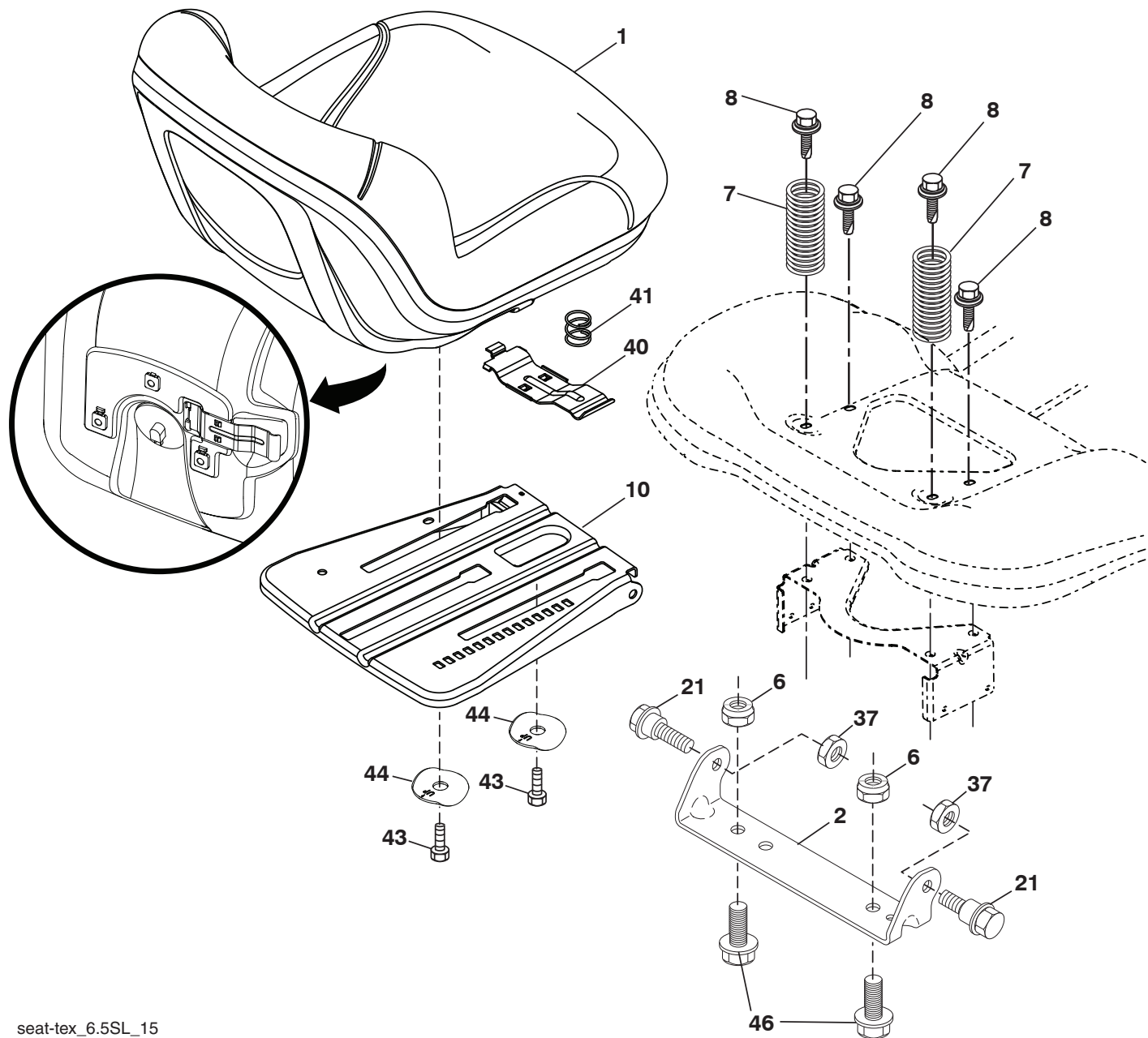

seat-tex_6.5SL_15

KEY NO.	PART NO.	DESCRIPTION
1	532 43 98-19	Seat
2	532 18 01-66	Bracket, Pivot, Fender
6	873 80 06-00	Nut, Lock w/Ins. 3/8-16 unc
7	589 48 35-01	Spring, Seat Cprsn
8	532 17 18-77	Bolt 5/16-18 unc x 3/4 w/Sems
10	596 65 74-02	Plate, Seat, Slide, 3Pt, MS431
21	587 90 78-01	Bolt, Shoulder 5/16-18 x 5/8
37	596 58 37-02	Nut w/Nonmetal, Ins, Blk, Zinc

KEY NO.	PART NO.	DESCRIPTION
40	595 08 81-02	Handle, Seat, Slide, E-Dip x 431
41	532 19 82-00	Spring, Latch, Seat
43	874 76 06-12	Bolt Fin Hex 3/8-16 unc x 3/4
44	501 05 18-01	Washer, Winged 3/8 ID 1.5 OD
46	588 09 04-01	Bolt 3/8-16 x 1: 1.25 OD Wshr.

NOTE: All component dimensions given in U.S. inches
1 inch = 25.4 mm

