

ILLUSTRATED PARTS LIST

MFG. ID NO. 96051016001

CUSTOMER CATALOG NO. TC 342

PRODUCT NO. 960 51 01-60

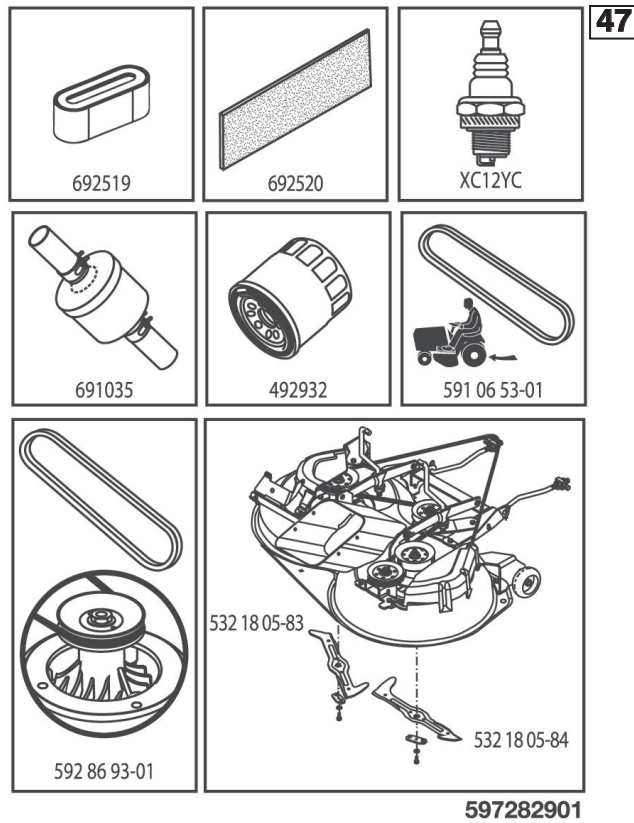

TRACTOR - MODEL NO. TC 342 (96051016001), PRODUCT NO. 960 51 01-60
DECALS 27

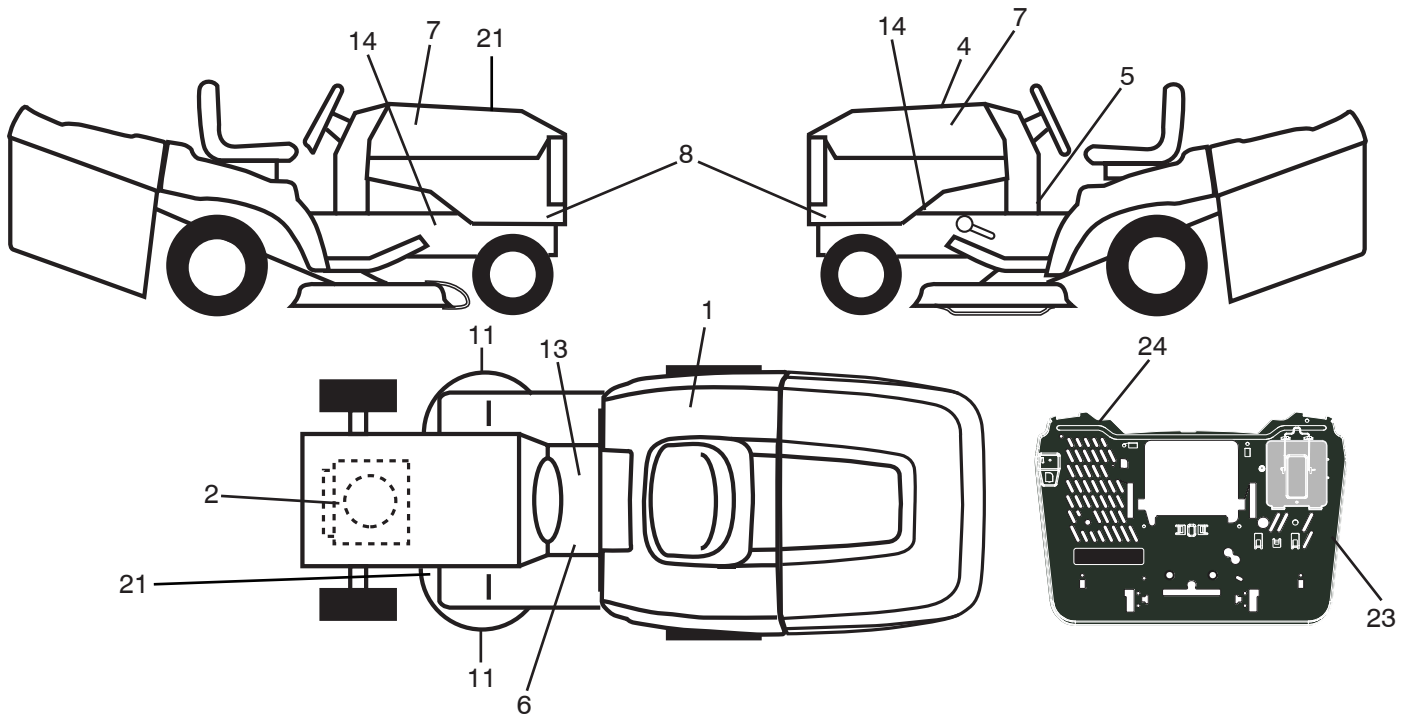

KEY NO.	PART NO.	DESCRIPTION
1	501 08 26-01	Decal, ECM Australia 2016
2	581 57 97-01	Decal, Engine
4	597 28 29-01	Decal, Replacement
5	581 57 84-01	Decal, Lower Dash
6	581 57 83-01	Decal, Warning
7	581 62 73-01	Decal, Hood
8	587 55 34-01	Decal, Side Panel
11	581 57 91-01	Decal, Mower Cut Finger Symbol

KEY NO.	PART NO.	DESCRIPTION
13	586 80 03-01	Decal, Tractor Saddle
14	581 57 96-01	Decal, Chassis Hot Muffler
21	592 98 02-01	Decal, Belt Schematic
23	532 44 46-19	Decal, Bypass
24	532 44 54-93	Decal, Warning Combined
--	532 44 14-09	Pad Footrest LH
--	532 44 14-10	Pad Footrest RH
--	114 11 05-26	Manual Operator's (English)

WHEELS AND TIRES

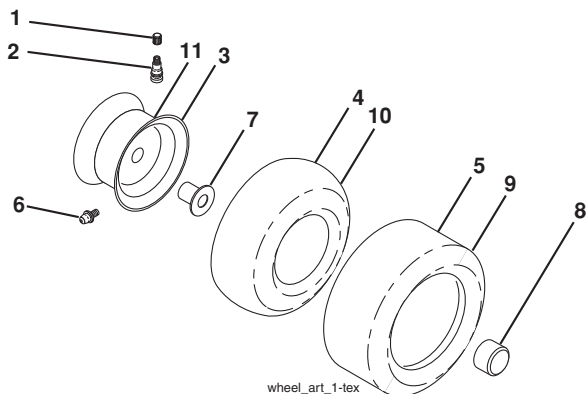

KEY NO.	PART NO.	DESCRIPTION
1	532 05 91-92	Cap Valve Tire
2	532 06 51-39	Stem Valve
3	532 13 83-36	Rim Front
4	532 05 99-04	Tube Front (Service Item Only)
5	532 17 04-55	Tire Front 15 x 6-6
6	532 12 49-57	Fitting Grease (Front Wheel Only)
7	532 12 49-59	Bearing Flange (Front Wheel Only)
8	532 17 50-39	Cap Axle Blk 1 50 x 1 00
9	588 69 19-01	Tire Rear 18 x 9.5-8
10	532 12 49-26	Tube Rear (Service Item Only)
11	532 13 83-37	Rim Asm 8" Rear
--	532 14 43-34	Sealant, Tire (10 oz. Tube)

NOTE: All component dimensions given in U.S. inches
 1 inch = 25.4 mm

TRACTOR - MODEL NO. TC 342 (96051016001), PRODUCT NO. 960 51 01-60

SCHEMATIC **38**

SCH19

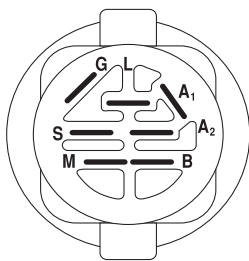
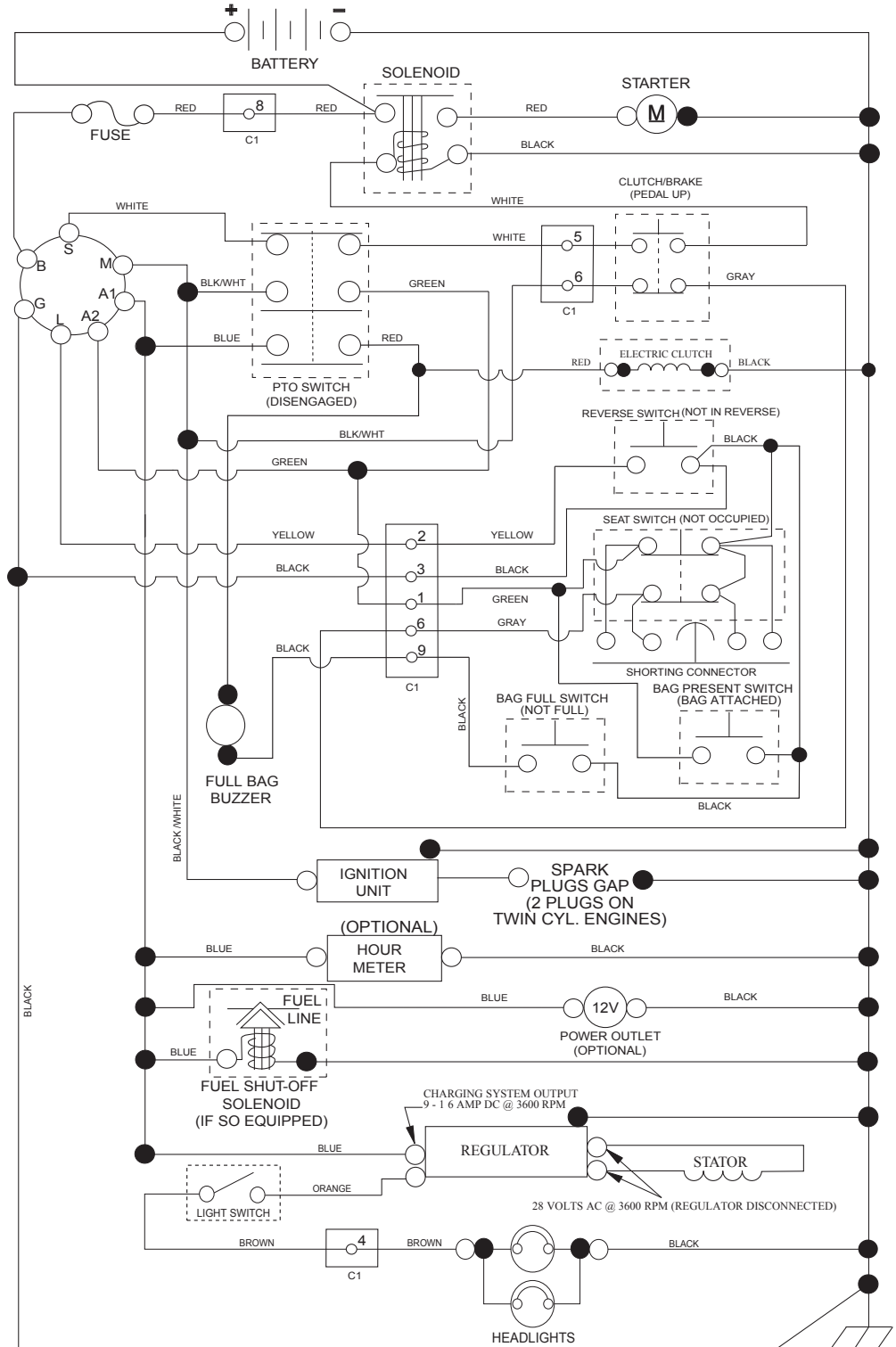

IGNITION SWITCH

POSITION	CIRCUIT	"MAKE"
OFF	M+G+A1	
RUN/OVERRIDE	B+A1	
RUN	B+A1	L+A2
START	B + S + A1	

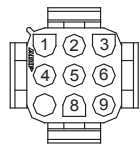

CHASSIS HARNESS CONNECTOR (C1) (MATING SIDE)

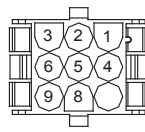

DASH HARNESS CONNECTOR (C1) (MATING SIDE)

WIRING INSULATED CLIPS
NOTE: IF WIRING INSULATED CLIPS WERE REMOVED FOR SERVICING OF UNIT, THEY SHOULD BE RE-INSTALLED TO PROPERLY SECURE YOUR WIRING.

● NON-REMOVABLE CONNECTIONS

○ REMOVABLE CONNECTIONS

TRACTOR - MODEL NO. TC 342 (96051016001), PRODUCT NO. 960 51 01-60
ELECTRICAL 32

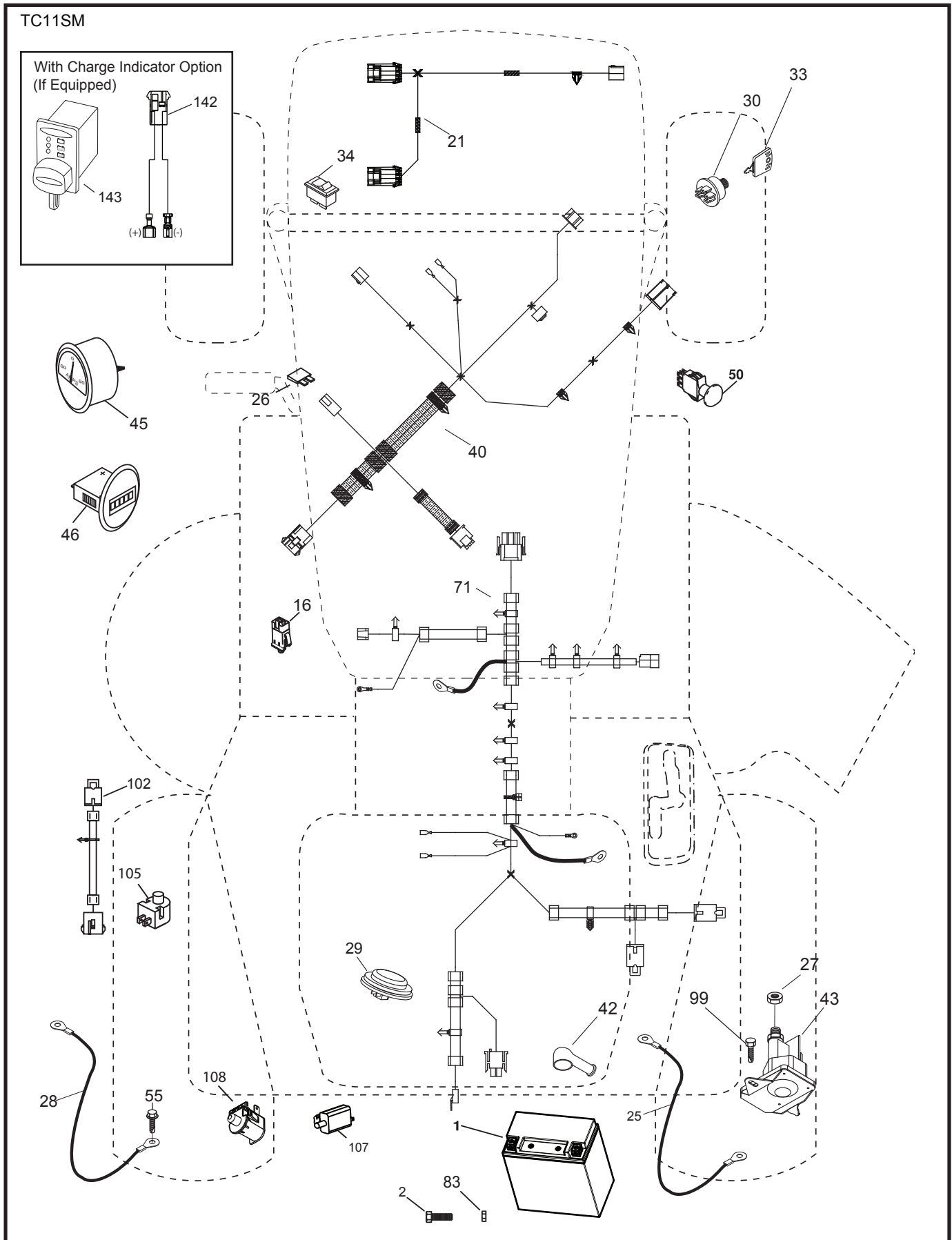

TRACTOR - MODEL NO. TC 342 (96051016001), PRODUCT NO. 960 51 01-60
ELECTRICAL 32

KEY NO.	PART NO.	DESCRIPTION
1	532 43 71-57	Battery
2	532 44 09-23	Screw Hex Hd Cap M6 x 1.12mm
16	532 17 61-38	Switch Interlock Push-In
21	585 43 64-01	Harness Light
25	589 32 37-01	Cable, Batt. 8 Ga. Red
26	532 17 51-58	Fuse
27	873 51 04-00	Nut Keps Hex 1/4-20 unc
28	589 32 36-01	Cable, Batt. BLCK10 SLV
29	532 40 15-45	Switch, Seat
30	532 19 33-50	Switch, Ign
33	532 41 19-35	Key/Chain
34	532 11 07-12	Switch Light
40	587 30 48-01	Harness Ign. Dash
42	532 13 15-63	Cover Terminal Red
43	582 04 28-01	Solenoid
45	587 55 39-03	Ammeter Guage Round
46	587 55 40-03	Gauge Serviceminder Hrmtr
50	582 10 76-01	Switch PTO
55	817 06 05-12	Screw Thdrol 5/16-18 x 3/4 TYTT
71	532 44 08-20	Harness Ignition Chassis
83	532 43 67-74	Nut Square M6 x 1.8.5 x 11mm
99	817 00 05-12	Screw 5/16-18 x 3/4
102	532 44 12-62	Harness Jumper
105	532 40 75-68	Switch Reverse
107	532 18 03-79	Switch Full Bagger
108	589 50 03-01	Switch Snapmount

NOTE: All component dimensions given in U.S. inches
1 inch = 25.4 mm

TRACTOR - MODEL NO. TC 342 (96051016001), PRODUCT NO. 960 51 01-60
CHASSIS AND ENCLOSURES 39

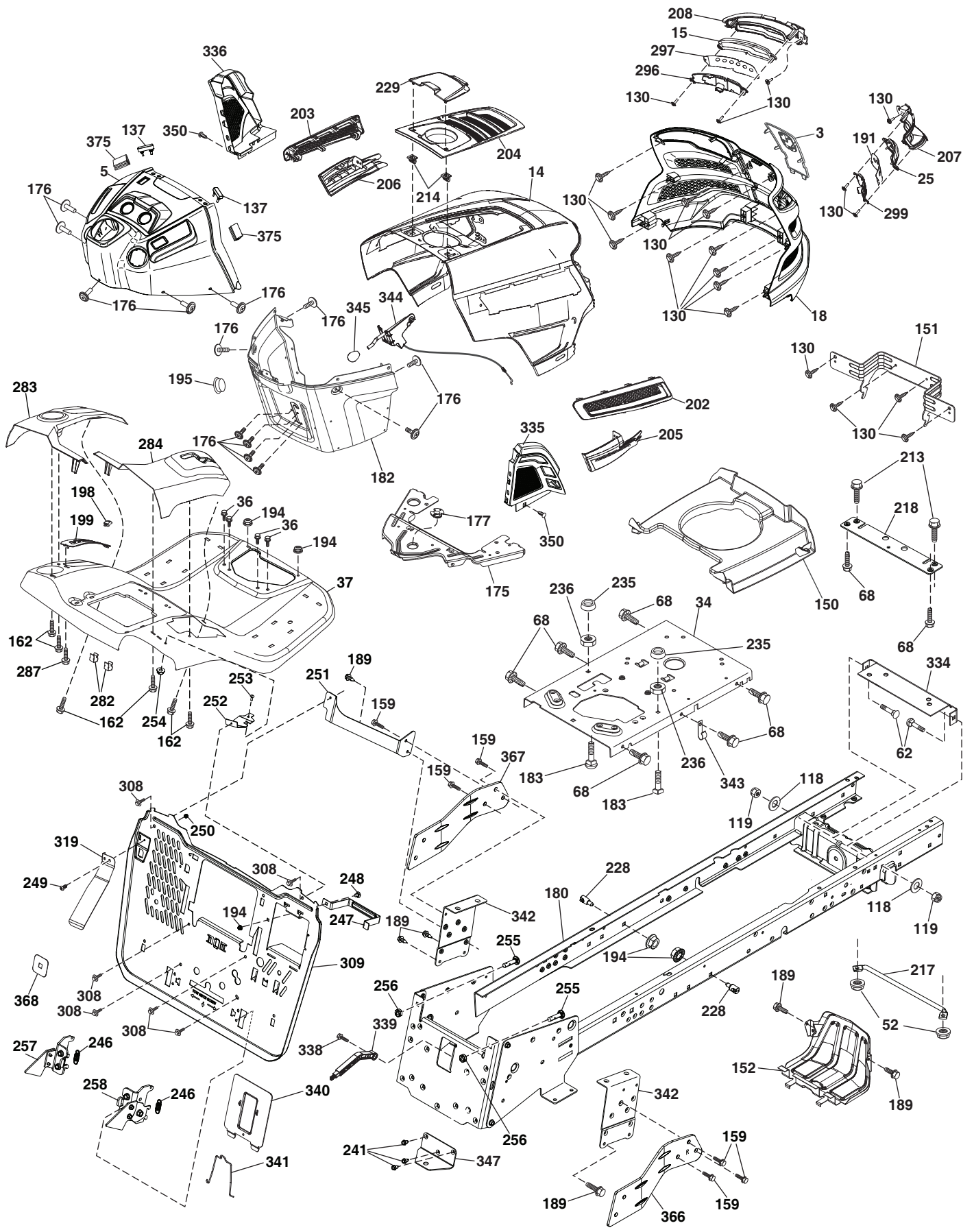

TRACTOR - MODEL NO. TC 342 (96051016001), PRODUCT NO. 960 51 01-60
CHASSIS AND ENCLOSURES 39

KEY NO.	PART NO.	DESCRIPTION	KEY NO.	PART NO.	DESCRIPTION
3	532 44 44-81	Applique	236	873 93 05-00	Nut Lock 5/16-18 unc
5	590 74 88-17	Dash	241	817 06 05-16	Screw 5/16-18 x 1 SMGML Tap/R
14	532 44 11-77	Hood	246	591 44 90-01	Spring TCRD Gen 2.5 Bagger Ext.
15	585 42 03-01	Lens LH	247	582 55 26-02	Strap Battery TCRD Gen 2.5 x .431
18	587 52 34-01	Grille	248	872 11 05-04	Bolt Carr 5/16-unc x1/2
25	585 42 02-01	Lens RH	249	586 93 60-01	Screw Button 10-24 x 1/2 Ptchd
34	580 91 09-01	Plate Engine	250	539 97 69-77	Nut #10-24 Hex Nylon Ring ZD
36	817 06 05-12	Screw 5/16-18 x 3/4	251	589 31 89-04	Backplate Support Bracket
37	532 44 14-19	Fender	252	581 99 22-04	Backplate Support Bracket
52	873 68 05-00	Nut Lock 5/16-18	253	539 11 56-20	Bolt Carr 1/4-20 x 3/4
62	872 11 06-08	Bolt RdHd Sqnk 3/8-16 x 1 Gr. 5	254	873 90 04-00	Nut Hex Flange 1/4-20 unc
68	539 99 08-58	Screw Thdrol 5/16-18 x 1/2	255	589 39 22-02	Bolt Cross Drilled 3/8-1/16 x 1.75
118	819 13 13-16	Washer 13/32 x 13/16 x 16 Ga.	256	532 19 70-33	Nut Jam 3/8-16
119	873 68 06-00	Nut Crownlock 3/8-16 unc	257	589 74 66-02	Bagger Latch Assembly LH
130	532 41 63-58	Screw #10 x 0.750	258	589 74 67-02	Bagger Latch Assembly RH
137	532 40 75-90	Bumper Dash	282	532 41 41-10	Clip Retainer
150	532 43 97-31	Air Duct	283	532 44 72-12	Console Deck Lift LH
151	532 43 66-70	Bracket Pivot	284	532 44 72-20	Console Shft RH
152	532 43 98-70	Shield Browning	287	817 60 04-06	Screw 1/4-20 x 3/8
159	817 00 06-12	Screw Hexwsh Thrd 3/8-16 x 3/4	296	585 42 05-01	LED Light LH
162	532 14 24-32	Screw	297	586 18 29-01	Insert Reflective LH
175	590 60 77-02	Crossmember	299	585 42 04-01	LED Light RH
176	532 40 07-76	Screw 10-24 x 5/8	308	532 17 18-77	Bolt 5/16-18 unc x 3/4
177	532 19 52-28	Bushing Steering	309	582 55 25-02	Backplate
180	593 89 88-01	Chassis	319	581 31 39-07	Lever Bag
182	532 43 89-67	Dash Lower	334	532 44 25-37	Bracket Engine
183	874 52 05-20	Bolt 5/16-18 x 1-1/4	335	532 44 82-04	Cover RH Lower Close Out
189	817 00 05-12	Screw 5/16-18 x 3/4	336	532 44 53-09	Cover LH Lower Close Out
191	586 18 28-01	Insert Reflective RH	338	532 43 66-40	Bolt Shoulder
194	873 90 05-00	Nut Lock Hex Flange 5/16-18	339	532 43 66-41	Lever Bagger Full
195	532 40 41-37	Plug Hole Dash Lower	340	582 55 27-02	Door Battery
198	532 44 15-52	Indicator Deck Lift	341	582 06 08-01	Latch Battery Door Tex CRD
199	532 41 87-39	Plate Deck Lift	342	582 82 68-02	Supprt Fender
202	532 43 97-28	Vent Side Hood RH	343	532 44 07-49	Clip
203	532 43 97-27	Vent Side Hood LH	344	532 43 89-70	Control EZ Mulch
204	532 44 06-65	Vent Top Hood	345	532 44 06-39	Knob
205	532 43 97-30	Trim Hood Side RH	347	532 44 28-87	Hitch Tow
206	532 43 97-29	Trim Hood Side LH	350	532 44 51-43	Clip X-Mas Tree
207	585 42 00-02	Bezel RH	366	581 31 46-02	Bracket RH Front Bagger
208	585 42 01-02	Bezel LH	368	581 42 48-01	Shourd Bag Full Lever
213	539 97 69-34	Bolt 5/16-18 x 3/4 Gr. 5 ZD	367	581 31 45-02	Bracket LH Front Bagger
214	532 19 91-45	Clip Retainer Tinner	375	586 90 82-01	Dash Clip-On Bumper
217	532 40 91-67	Rod Pivot	--	532 43 18-82	Kit Brush Guard
218	532 19 63-95	X-Piece Hood Stop			
228	532 19 51-61	Stud Fastner			
229	532 44 14-63	Lid Ext			
235	532 40 61-29	Spacer Fender			

NOTE: All component dimensions given in U.S. inches
1 inch = 25.4 mm

TRACTOR - MODEL NO. TC 342 (96051016001), PRODUCT NO. 960 51 01-60
DRIVE 40

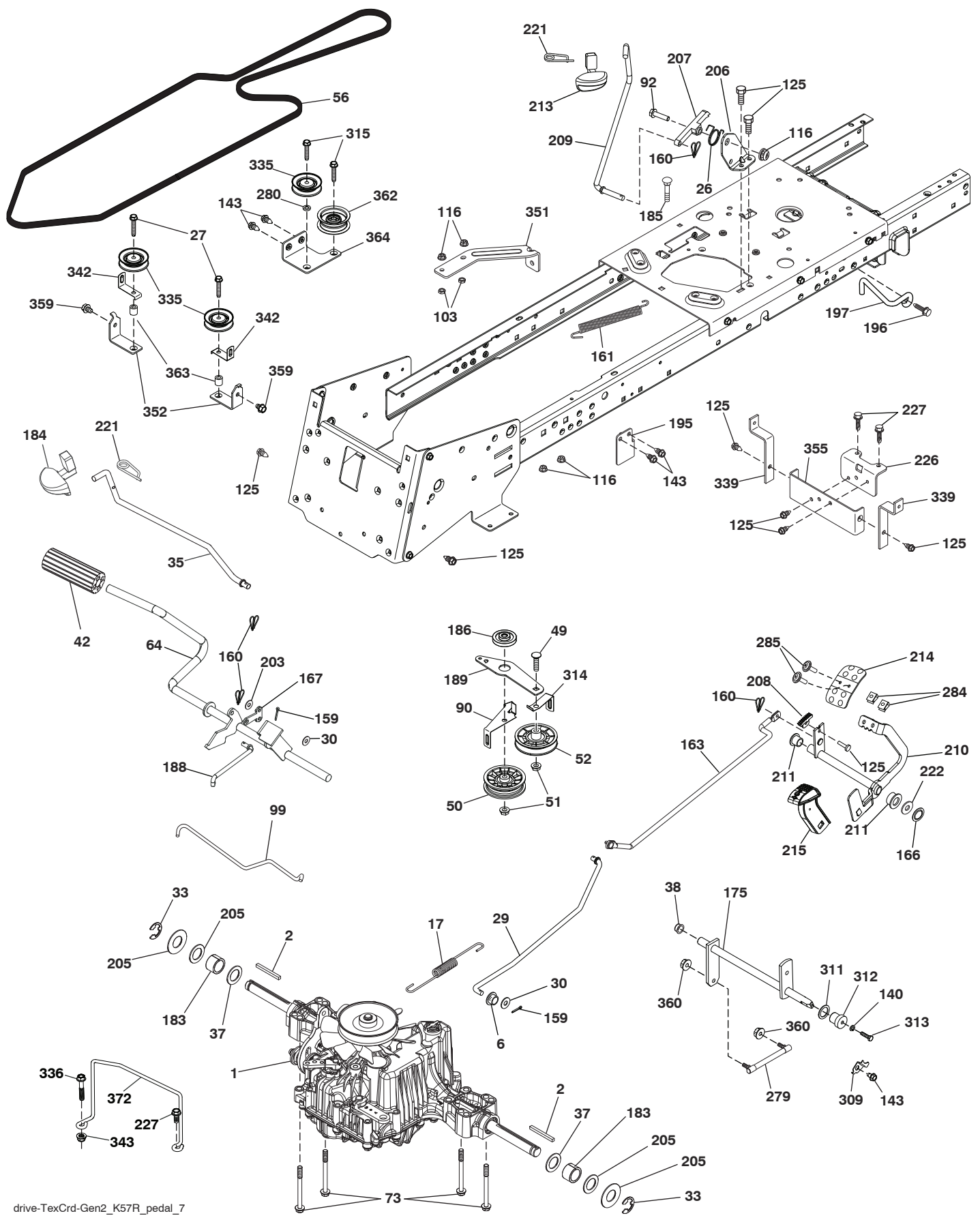

drive-TexCrd-Gen2_K57R_pedal_7

**TRACTOR - MODEL NO. TC 342 (96051016001), PRODUCT NO. 960 51 01-60
DRIVE **40****

KEY NO.	PART NO.	DESCRIPTION	KEY NO.	PART NO.	DESCRIPTION
1	---	Transaxle, Tufftorq K57AH (585743601) (Order parts from transaxle manufacturer.)	196	817 00 06-16	Screw 3/8-16 x 1 SMGML Tap/R Blk
2	532 12 35-83	Key Square	197	585 65 86-01	Link Clutch Anti-Rotation
6	532 12 40-28	Bushing Snap	203	819 11 11-16	Washer 11/32 x 11/16 x 16 Ga.
17	532 43 62-27	Spring Brake K46	205	532 12 17-48	Washer 25/32 x 1-5/8 x 16 Ga.
26	532 19 96-79	Spring Return Cruise	206	532 44 85-96	Bracket Mount Latch Cruise
27	817 49 05-28	Screw Hexwsh Thd 5/16-18 x 1-3/4	207	587 03 14-01	Latch Control Cruise
29	532 44 27-95	Rod, Brake	208	532 19 78-69	Gear Sector Control Cruise
30	819 13 16-16	Washer	209	532 19 95-92	Rod Control Cruise
33	812 00 00-01	Ring E	210	532 40 09-80	Rocker Asm. Pedal Control
35	583 86 45-01	Rod, Brake, Park	211	532 12 01-83	Bearing Nylon
37	532 18 89-67	Washer Harden .793 x 1.063 x .060	213	532 40 31-19	Knob Control Cruise
38	532 16 96-13	Nyliner Bushing	214	532 41 68-63	Pedal Forward
42	532 12 48-72	Cover, Foot Pedal	215	586 60 65-02	Pedal Reverse
49	872 11 06-14	Bolt Rdhd 3/8-16 unc x 3/4 Gr. 5	221	532 40 31-87	Retainer Spring Clip Handle
50	532 19 43-27	Idler Flat	222	879 21 20-10	Washer 21/32 x 1-1/4 10 Ga.
51	873 90 06-00	Lock Nut 3/8-16	226	532 40 15-64	Bracket Strap Torque
52	532 19 43-26	Idler V-Groove	227	817 49 05-12	Screw
56	591 06 53-01	V-Belt, Drive	279	532 44 42-83	Link Shift
64	532 19 78-65	Shaft Asm. Pedal Brake Control	280	819 11 10-12	Washer 11/32 x 5/8 x 12 Ga.
73	874 49 05-44	Bolt Flanged	284	532 41 76-93	Nut
90	532 44 36-05	Keeper Belt Clutching	285	874 18 04-12	Screw
92	874 76 05-20	Bolt Fin Hex 5/16-18 unc x 1.25	309	532 16 55-81	Plate Fstnr Cross Shf
99	532 44 39-47	Rod Spring Bypass	311	532 16 98-45	Washer Nylon
103	873 35 05-00	Nut Hex Jam 5/16-18	312	532 16 56-14	Hub Tapered
116	873 90 05-00	Nut Lock Hex Flange 5/16-18	313	874 78 04-16	Bolt Hex Fin 1/4-20 unc x 1 Gr. 5
125	817 00 05-12	Screw 5/16-18 x 3/4	314	532 44 47-13	Keeper Belt
140	810 04 04-00	Washer Lock Hvy Helical 1/4	315	817 58 05-20	Screw Thdrol 5/16-18 x 4.25
143	539 99 08-58	Screw 5/16-18 x 1/2	335	532 19 95-34	Pulley V-Idler
159	876 02 04-12	Pin Cotter 1/8 x 3/4	336	587 25 96-01	Bolt 5/16-18 x 1-3/4 Flanged hex
160	532 16 94-84	Retainer Clip	339	532 43 68-67	Strap Torque K46 CRD TEX
161	532 10 57-09	Spring, Return, Clutch	342	532 18 26-82	Keeper Belt 2.5" STL V-Idlr CRD
163	532 44 27-93	Rod Control	343	539 11 28-99	Nut 5/16-18 Hex Flanged Nyloc
166	532 42 91-64	Nut Push	351	532 43 69-98	Bracket 97 CRD Deck Sway
167	532 40 52-57	Latch Brake Parking	352	532 43 56-45	Bracket Idler CRD Tex
175	532 42 93-59	Shaft Asm Crossshift Rear CRD	355	532 43 56-69	Bracket
183	532 13 70-57	Spacer Axle	359	817 49 06-10	Screw Thdrol 3/8-16 x 5/8
184	587 65 37-01	Handle Parking Brake	360	532 44 47-14	Nut 5/16-24 unf
185	872 11 06-22	Bolt 3/8-16 unc x 2-3/4 Gr. 5	362	532 43 68-12	Idler Flat
186	532 19 43-21	Spacer Retainer	363	532 44 27-80	Spacer 343 x 63 x .62
188	582 21 70-01	Link Clutch	364	532 44 30-32	Bracket Idler CRD Tex
189	532 43 36-11	Bellcrank Ground Drive	372	582 65 49-01	Keeper Belt Transaxle
195	580 45 69-01	Bracket Rod Brake CRD Tex			

NOTE: All component dimensions given in U.S. inches
1 inch = 25.4 mm

**TRACTOR - MODEL NO. TC 342 (96051016001), PRODUCT NO. 960 51 01-60
ENGINE 24**

KEY NO.	PART NO.	DESCRIPTION
1	— — — — —	Engine B&S Model No. 385777-0007-G1 (588627901) (Order parts from engine manufacturer.)
2	589 81 87-01	Muffler
9	501 83 26-02	Keeper Belt Engine
11	592 82 17-01	Clutch Electric
12	532 40 50-97	Pulley Engine
15	532 43 58-16	Tank Fuel
18	532 44 14-62	Fuel Cap
20	532 42 43-41	Control Throttle
21	532 41 63-58	Screw # 10 x 0.750
22	532 18 95-41	Control Choke
28	532 13 70-40	Fuel Line
29	532 13 71-80	Spark Arrester Kit
37	532 12 34-87	Clamp Hose
41	532 12 61-97	Washer 1-1/2 OD x 15/32 ID x .250
42	539 99 02-47	Washer SLW STD 7/16
45	873 51 04-00	Nut Keps Hex 1/4-20 unc
62	532 43 40-17	Shield Heat Muffler
69	532 19 24-42	Gasket
70	532 19 15-48	Tube Exhaust LH
71	532 19 15-49	Tube Exhaust RH
79	532 19 24-43	Screw
81	532 14 84-56	Tube Drain Oil Easy
82	532 42 82-87	Valve Oil Drain
84	817 06 06-20	Screw
85	501 60 66-01	Bolt Hex 7/16-20 x 3.75 Gr. 5
90	817 00 06-16	Screw 3/8-16 x 1
96	819 09 14-16	Washer 9/32 x 7/8 x 16 Ga.
97	817 67 04-12	Screw 1/4-20 x 3/4
102	817 00 05-12	Screw 5/16-18 x 3/4
116	539 13 26-24	Knob Shift
137	532 44 14-61	Spill Cup

NOTE: All component dimensions given in U.S. inches
1 inch = 25.4 mm

Engine Power Rating Information

The gross power rating for individual gas engine models is labeled in accordance with SAE (Society of Automotive Engineers) code J1940 (Small Engine Power & Torque Rating Procedure), and rating performance has been obtained and corrected in accordance with SAE J1995 (Revision 2002-05). Torque values are derived at 3060 RPM; horsepower values are derived at 3600 RPM. Actual gross engine power will be lower and is affected by, among other things, ambient operating conditions and engine-to-engine variability. Given both the wide array of products on which engines are placed and the variety of environmental issues applicable to operating the equipment, the gas engine will not develop the rated gross power when used in a given piece of power equipment (actual “on-site” or net power). This difference is due to a variety of factors including, but not limited to, accessories (air cleaner, exhaust, charging, cooling, carburetor, fuel pump, etc.), application limitations, ambient operating conditions (temperature, humidity, altitude), and engine-to-engine variability. Due to manufacturing and capacity limitations, Briggs & Stratton may substitute an engine of higher rated power for this Series engine.

TRACTOR - MODEL NO. TC 342 (96051016001), PRODUCT NO. 960 51 01-60
STEERING ASSEMBLY 41

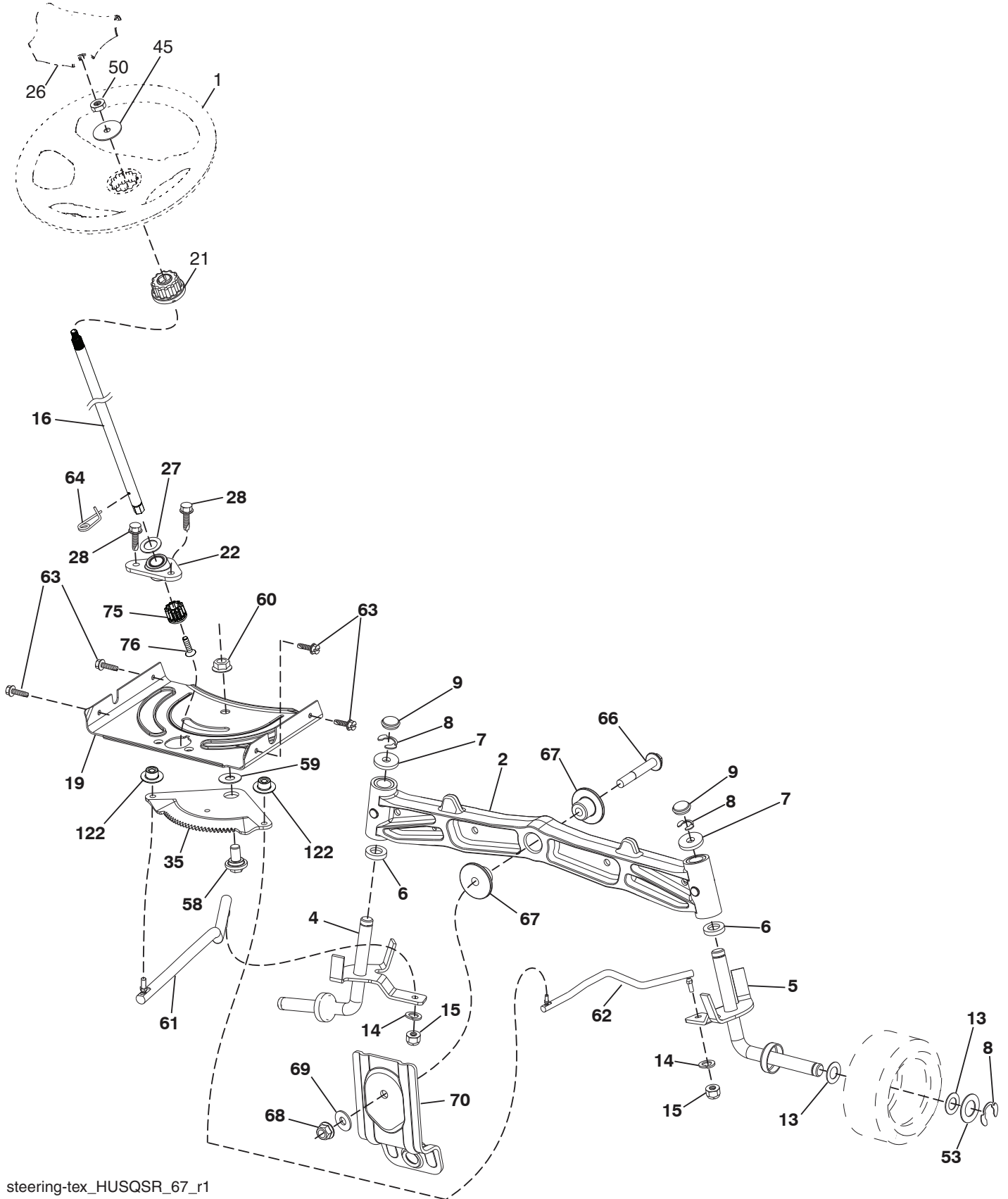

steering-tex_HUSQSR_67_r1

TRACTOR - MODEL NO. TC 342 (96051016001), PRODUCT NO. 960 51 01-60
STEERING ASSEMBLY 41

KEY NO.	PART NO.	DESCRIPTION
1	532 43 97-40	Wheel, Steering
2	532 19 59-68	Axle Asm., Front
4	532 40 30-87	Spindle Asm., LH
5	532 40 30-88	Spindle Asm., RH
6	532 12 49-31	Bearing, Race Thrust Harden
7	532 12 17-48	Washer 25/32 x 1-5/8 x 16 Ga.
8	812 00 00-29	Ring, Clip #T5304-75
9	532 12 12-32	Cap, Spindle
13	532 12 17-49	Washer 25/32 x 1-1/4 x 16 Ga.
14	539 99 01-18	Washer, SLW ZD 3/8
15	873 54 06-00	Nut, Crown Lock 3/8-24 unf
16	587 01 60-02	Steering Shaft
19	532 19 47-29	Plate Steering
21	586 84 02-01	Adapter Wheel Steering
22	585 02 98-02	Bearing Shaft
26	532 43 97-43	Insert, Wheel Steering
27	819 21 16-16	Washer 21/32 x 1 x 16 Ga.
28	817 00 06-12	Screw 3/8-16 x 3/4
35	532 19 47-32	Gear, Sector Plate
45	587 01 64-01	Washer 3/8 ID 2-3/8 OD 12 Ga.
50	873 90 06-00	Nut Lock Flg 3/8-16 unc
53	532 18 89-67	Washer Hardened .793 x 1.637 x .060
58	532 19 47-47	Bolt Shoulder Sector Pivot CFM
59	532 19 47-48	Washer Thrust Sector Steering
60	873 97 10-00	Nut Flange Lock 5/8-11
61	588 79 44-01	Draglink, LH
62	588 79 45-01	Draglink, RH
63	817 00 05-12	Screw 5/16-18 x 3/4
64	532 19 98-49	Retainer Clip Spring Steering
66	871 02 07-48	Bolt Hex Fghd 7/16-14 x 3 Serr
67	532 19 47-37	Bushing PM Front Axle
68	873 90 07-00	Nut Lock Flange 7/16-14 Gr. 5
69	532 19 91-62	Washer 1.5 x .505 x .118
70	585 33 88-01	Bracket Deck Susp. Front
75	580 68 37-01	Pinion
76	580 68 36-01	Screw Head Sock
122	532 44 49-62	Cap Gear

NOTE: All component dimensions given in U.S. inches
1 inch = 25.4 mm

TRACTOR - MODEL NO. TC 342 (96051016001), PRODUCT NO. 960 51 01-60
MOWER DECK 44

KEY NO.	PART NO.	DESCRIPTION	KEY NO.	PART NO.	DESCRIPTION
1	596 76 28-01	Kit SVC Deck Weldment	99	532 19 51-86	Arm Suspension Mower Rear
2	532 42 30-62	Palnut 1/4	100	532 19 65-39	Bolt Shoulder
3	873 90 05-00	Nut Lock Hex Flange 5/16-18	104	592 86 57-01	Mandrel Cover RH
4	872 11 05-10	Bolt Carr. 5/16-18 x 1-1/4 Gr. 5	105	532 44 47-55	Mandrel Cover LH
5	817 00 05-10	Bolt 5/16-18 Hex Whs Hd Lckserr	117	873 90 04-00	Nut Hex Flange 1/4-20 unc
9	585 69 13-01	Nut Hex Flg 5/16-18	118	592 86 58-02	Arm Clutching
11	532 13 77-29	Screw Thd Roll 1/4-20 x 5/8	122	532 16 57-23	Spacer Retainer
12	539 11 28-99	Nut Hex Flg 5/16-18	123	872 11 06-10	Bolt RDHD 3/8-16 x 1.25
13	872 11 06-12	Bolt Carr Sh 3/8-16 x 1-1/2 Gr. 5	124	532 16 54-82	Non Greasable Mandrel Shaft
14	532 15 60-85	Keeper Belt Idler	127	532 19 34-06	Bolt Shoulder 3/8-16 x 3-5/8 Gr. 5
15	532 19 59-45	Pulley Mandrel	128	589 52 73-01	Wheel Gauge
16	873 90 06-00	Nut Lock FIG 3/8-16 unc	129	532 44 32-37	Rod Anti-Sway
17	532 40 02-34	Nut Flange Lock Top	130	819 13 13-12	Washer 13/32 x 13/16 x 12 Ga.
18	532 18 76-90	Washer, Spacer, Mandrel	131	532 19 42-08	Pin Cotter 5/16 Bow Tie Lock
19	585 32 39-01	Bearing Mandrel	133	532 43 81-97	EZ Mulch Door
21	532 17 85-15	Washer Flat Hardened	134	532 43 58-61	Pin Hinge
22	592 85 47-02	Bracket Clutching Arm	135	532 43 79-88	E-Ring 5/16
23	817 49 06-28	Screw Thdrol 3/8-16 x 1-3/4	146	532 44 58-96	Spring Tex CRD EZ Mulch
24	594 97 29-03	Bracket Angles V-Idler	150	596 01 30-02	Weldment Chute Lower 107 CRD
27	592 86 93-01	V-Belt Drive	154	532 19 98-55	Screw 1/4-20 Panhead
28	592 86 59-02	Idler Keeper	159	585 30 94-05	Plate LH Side
31	587 35 84-01	Spring Ext.	160	585 30 95-05	Plate LH Front
33	532 18 72-81	Housing, Mandrel, 4 pt.	161	585 31 60-05	Plate RH Front
34	587 25 65-01	Shaft, Asm, Mandrel	162	585 31 61-05	Plate RH Side
35	532 18 05-83	Blade Mower LH	164	589 35 85-02	Baffle Plate LH
39	581 52 65-01	Washer 7/16 Flat	165	587 42 61-02	Baffle Plate RH
41	539 99 02-47	Washer lock 7/16	166	592 85 60-01	Bracket Tension Adjustment
43	532 44 32-39	Pulley Mandrel	248	589 00 98-02	LH Rear Steel Guard
44	532 19 95-34	Pulley V-Idler Ground	249	589 00 97-02	LH Front Steel Guard
45	532 12 87-74	Mandrel Asm. Short	255	592 80 78-01	Bolt 1/4-20 x 3/4 Short Neck
47	584 30 93-01	Screw Sems 7/16-20 x 1 Hex Head	258	584 95 39-01	Bolt Hex Wsh Hd .316-18 x 1.19
52	594 97 26-03	Bracket Center V-Idler	264	589 39 29-01	Retainer Asm. Upper Chute
54	539 99 05-85	Nut Hex 5/16-18	--	587 25 33-01	Mandrel Assembly Tall (Includes Housing (key #33), Shaft Assembly (key #34), And Bearing Only (key #19) - Pulley/Nut/Washer And Blade Bolt/Washers Not Included)
60	819 12 14-14	Washer 5/16 Flat STE STD ZD	--	581 65 05-01	Mandrel Assembly - Short (Includes Housing (key #45), Shaft Assembly (key #124), And Bearing Only (key #19) - Pulley/Nut/Washer And Blade Bolt/Washers Not Included)
72	581 45 41-03	Chute Upper	--	596 76 29-01	Replacement Mower Complete
74	539 11 55-74	Bolt Eye 5/16 x 3-1/2			
75	532 17 34-38	Pulley Idler Flat			
76	532 43 96-40	Washout Port			
78	532 17 39-02	Pulley Idler			
80	539 99 03-16	RHSNB 5/16-18 x 3/4 Gr. 5 ZD			
84	532 44 32-35	Keeper Belt Mandrel			
85	532 18 05-84	Blade Mower RH			
86	532 18 17-13	Bolt 3/8-24 x 1.50 Gr.8			
87	539 99 01-18	Washer Lock Hvy 3/8			
88	532 14 02-96	Washer, Hard, Blade, Mover			
96	532 40 02-71	Spacer			
97	532 18 20-61	Shield Idler Mower			
98	532 19 51-61	Stud Fastener			

NOTE: All component dimensions given in U.S. inches
1 inch = 25.4 mm

TRACTOR - MODEL NO. TC 342 (96051016001), PRODUCT NO. 960 51 01-60
MOWER LIFT 45

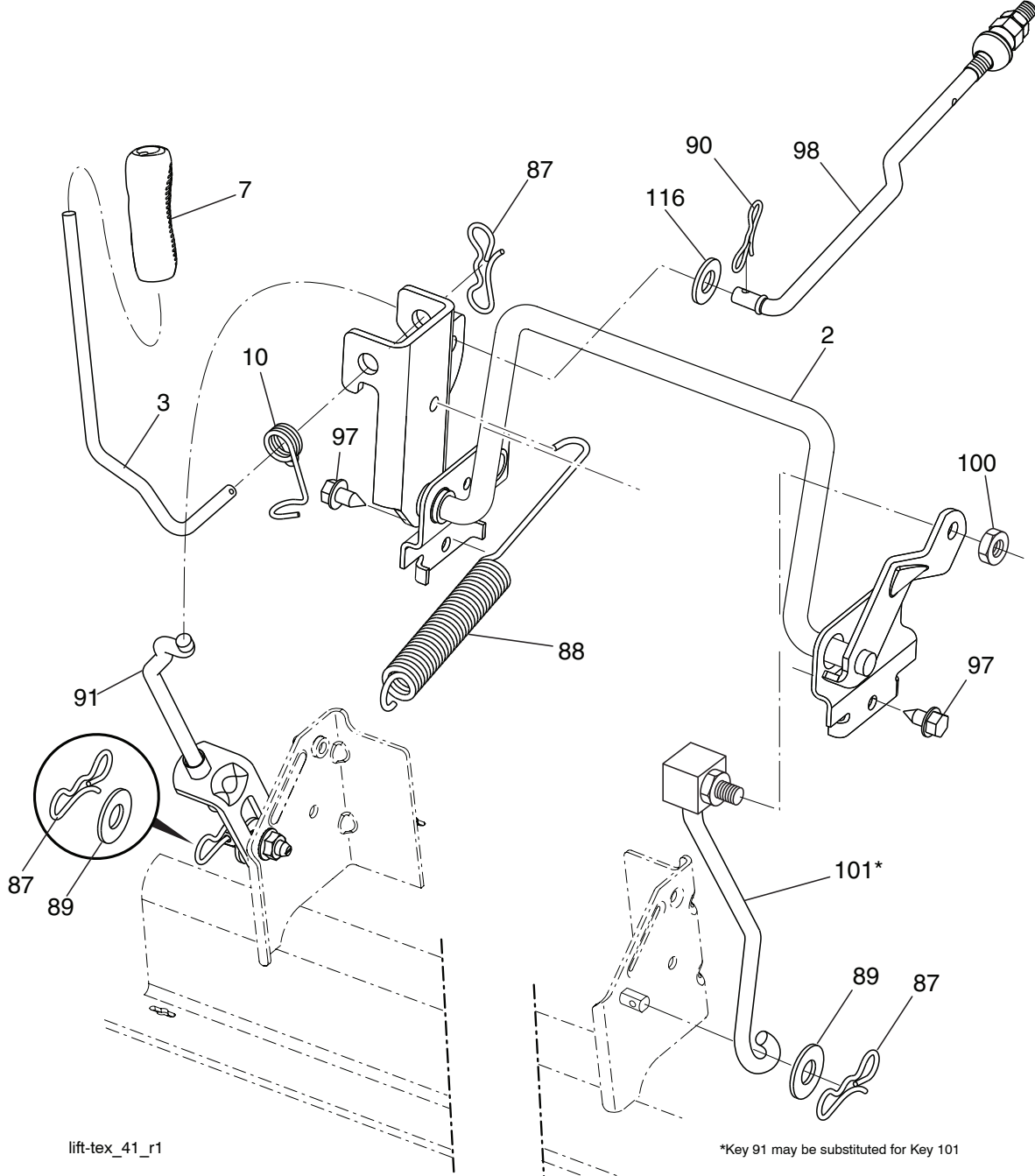

KEY NO.	PART NO.	DESCRIPTION
2	532 43 69-96	Deck Lift Weldment
3	532 19 52-31	Lever Asm., Lift RH
7	580 96 23-01	Grip, Lever
10	532 19 63-14	Spring Torsion
87	532 19 42-09	Pin Cotter 7/16 Bow Tie Lock
88	532 44 54-96	Spring Lift Assist
89	819 19 19-12	Washer Clear Zinc
90	532 19 42-08	Pin Cotter 5/16 Bow Tie Lock
91	532 19 51-81	Link Lift Susp Mower Rear

KEY NO.	PART NO.	DESCRIPTION
97	817 49 06-08	Screw 3/8-16 x 1/2
98	532 19 52-70	Link Lift Susp. Front Mower
100	873 93 06-00	Nut Centerlock
101	532 40 70-03	Link Asm. Lift
116	819 15 15-16	Washer 15/32 x 15/16 x 16 Ga.

NOTE: All component dimensions given in U.S. inches
 1 inch = 25.4 mm

TRACTOR - MODEL NO. TC 342 (96051016001), PRODUCT NO. 960 51 01-60
SEAT ASSEMBLY 42

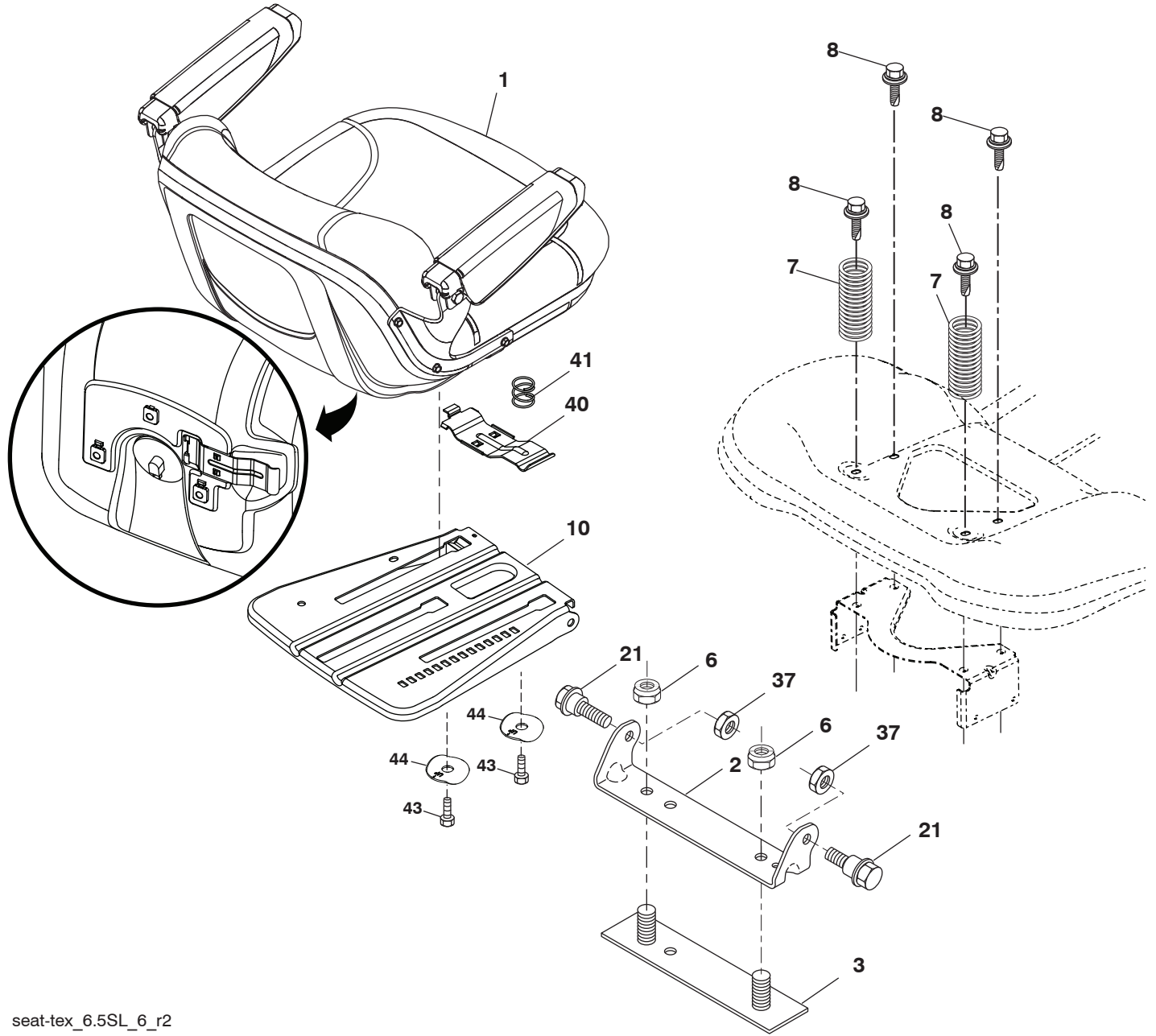

seat-tex_6.5SL_6_r2

KEY NO.	PART NO.	DESCRIPTION
1	588 55 67-01	Seat
2	532 18 01-66	Bracket Pivot Fender
3	532 14 06-75	Strap, Asm Fender
6	873 80 06-00	Nut, Lock W/Ins. 3/8-16 unc
7	589 48 35-01	Spring, Seat Cprsn
8	532 17 18-77	Bolt 5/16-18 unc x 3/4 w/Sems
10	596 65 74-02	Pan, Seat
21	587 90 78-01	Bolt, Shoulder 5/16-18 x 5/8

KEY NO.	PART NO.	DESCRIPTION
37	873 80 05-00	Nut, Lock 5/16-18 unc
40	532 19 76-61	Handle Slide Seat
41	532 19 82-00	Spring Latch Seat
43	874 76 06-12	Bolt Fin Hex 3/8-16 unc x 3/4
44	501 05 18-01	Washer Winged 3/8 ID 1.5 OD

NOTE: All component dimensions given in U.S. inches
 1 inch = 25.4 mm

TRACTOR - MODEL NO. TC 342 (96051016001), PRODUCT NO. 960 51 01-60
BAGGER **46**

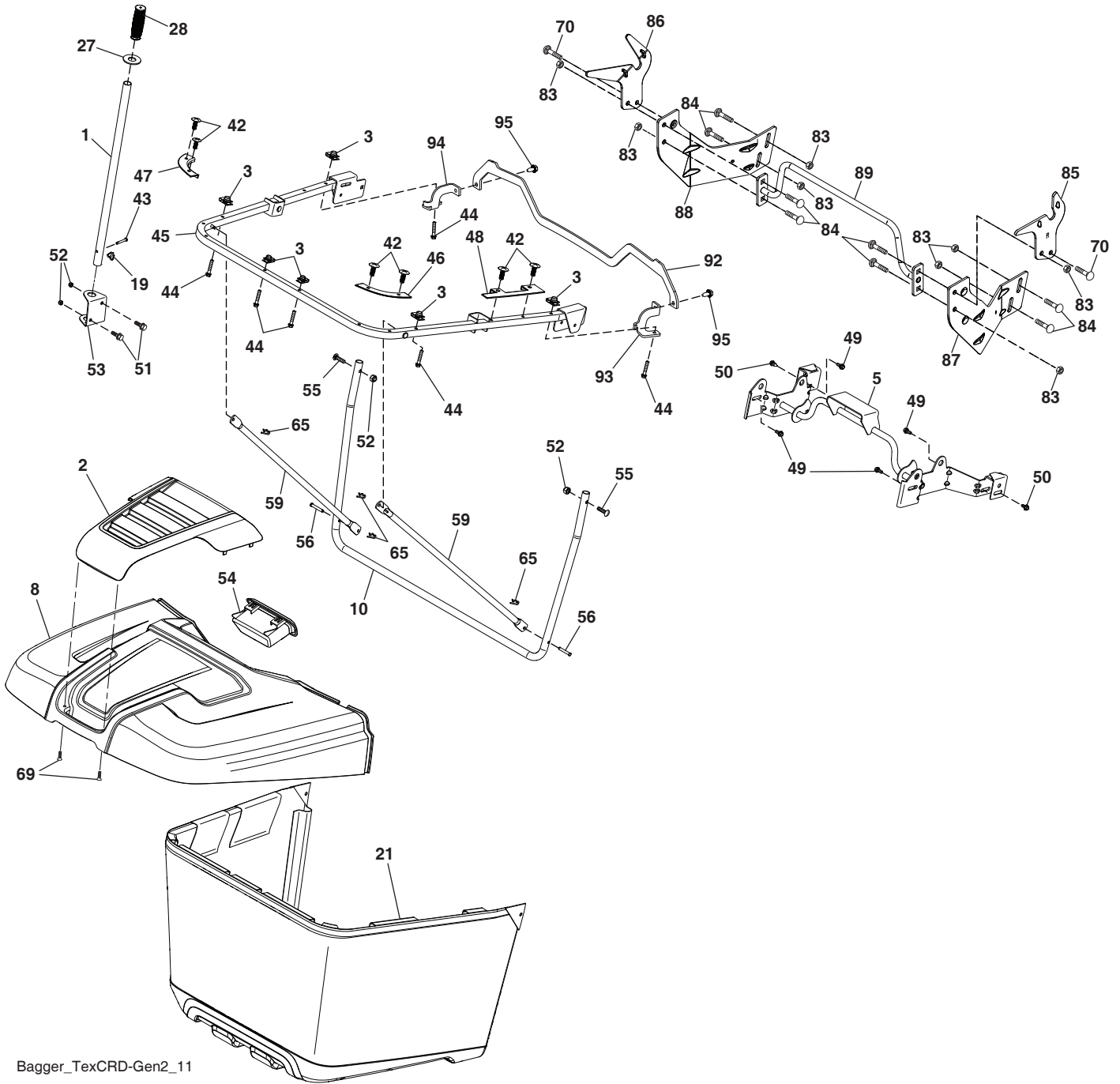

Bagger_TexCRD-Gen2_11

**TRACTOR - MODEL NO. TC 342 (96051016001), PRODUCT NO. 960 51 01-60
BAGGER 46**

KEY NO.	PART NO.	DESCRIPTION
1	532 42 86-10	Tube Handle Bagger
2	532 44 75-72	Applique
3	532 17 48-14	Palnut 1/4 Lugs
5	532 44 37-62	Upper Pivot Tube
8	532 44 75-75	Bagger Top
10	532 44 37-55	Frame Front
19	532 19 42-08	Cotter Pin 5/16 Bow Tie
21	581 33 71-03	Bag Asm
27	532 44 55-29	Grommet Rubber
28	532 16 57-87	Grip Handle
42	532 44 04-28	Clip
43	532 12 68-75	Clevis Pin
44	532 19 96-87	Bolt 1/4-20
45	532 44 37-54	Upper Frame
46	532 44 55-41	Bag Corner Close Out RH
47	532 44 40-79	Bag Corner Close Out LH
48	532 44 40-80	Top Bagger Side Close Out
49	532 17 18-73	Bolt Shoulder 5/16-18
50	532 17 18-77	Bolt 5/16-18 x 3/4 W/Sems
51	872 05 05-06	Bolt 5/16 x 18 x 3/4
52	873 80 05-00	Nut Lock Hex W/Ins 5/16-18 unc
53	532 44 41-95	Bracket Dump Handle
54	532 44 72-18	Bagger Top Front Handle
55	539 10 29-33	Bolt 5/16-18 x 1-1/2 Gr. 5 ZD
56	532 42 03-06	Pin Clevis .183 x 1.26
59	532 44 47-63	Bagger Sprd Tube
65	532 12 47-88	Retainer Spring 1" Zinc
69	532 42 18-01	Screw #8 Flat Head Drill
70	817 00 06-12	Screw 3/8-16 x 3/4
83	873 80 06-00	Nut Lock Hex w/Ins. 3/8-16 unc
84	872 11 06-08	Bolt 3/8-16 x 1 Gr. 5
85	581 31 44-02	Bracket RH Pivot
86	581 31 43-02	Bracket LH Pivot
87	581 31 48-02	Bracket RH
88	581 31 47-02	Bracket LH
89	581 31 51-04	Weldment Offset Strut
92	586 05 23-02	Bracket Top Support
93	586 05 24-02	Bracket Support RH
94	586 05 25-02	Bracket Support LH
95	817 00 05-12	Screw 5/16-18 x 3/4

NOTE: All component dimensions given in U.S. inches
1 inch = 25.4 mm

