

ILLUSTRATED PARTS LIST

MFG. ID NO. 96041040300

CUSTOMER CATALOG NO. YTH2642TDF

PRODUCT NO. 960 41 04-03

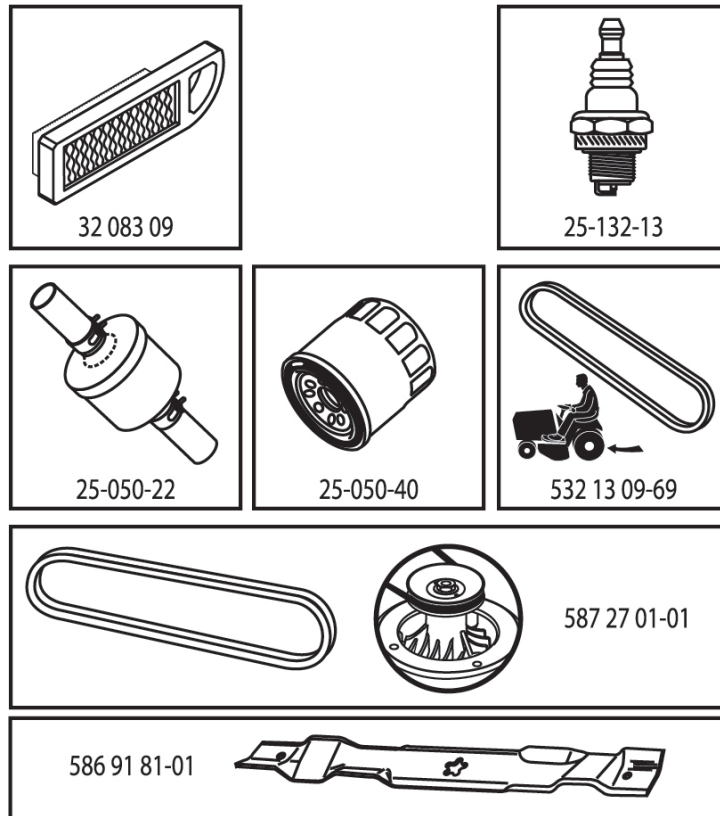

47

590501401

**TRACTOR - - MODEL NO. YTH2642TDF (96041040300), PRODUCT NO. 960 41 04-03
DECALS 27**

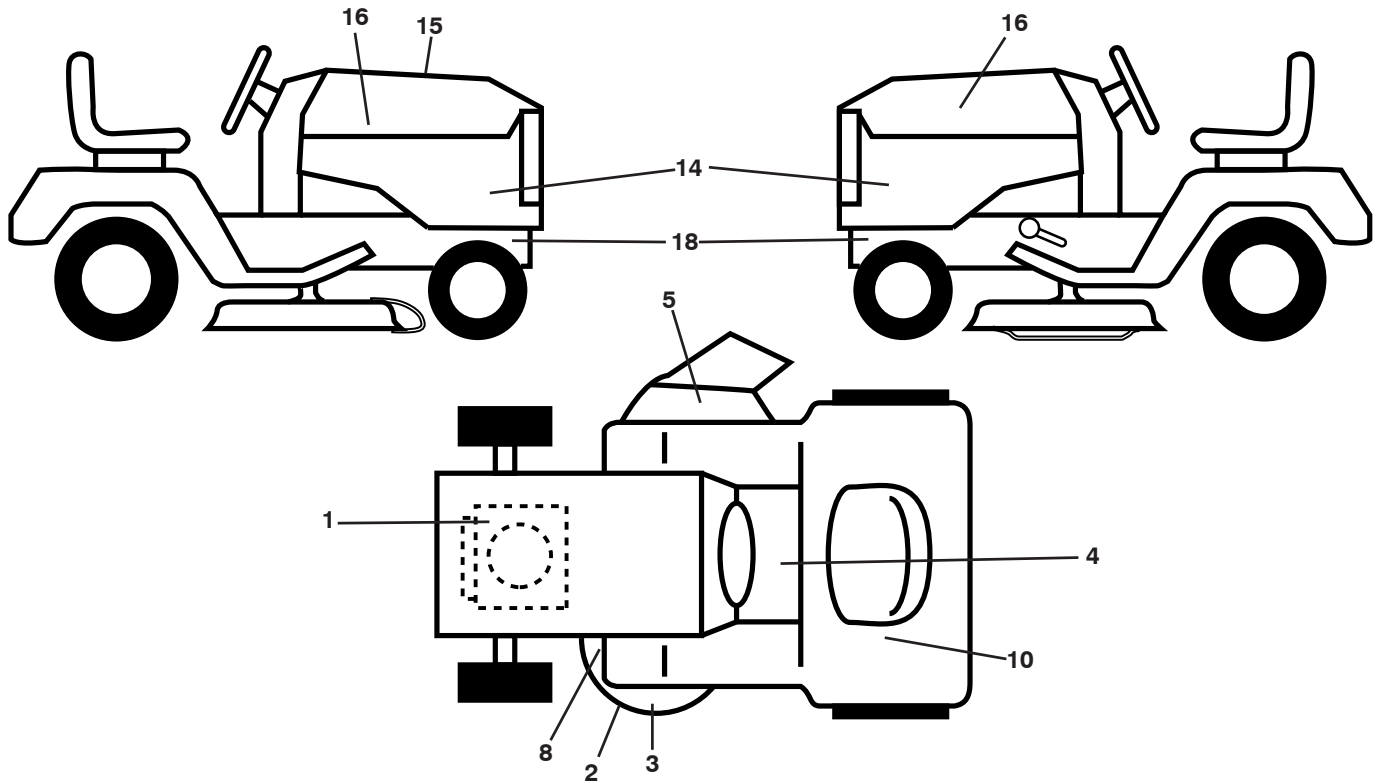

KEY NO.	PART NO.	DESCRIPTION
1	581 57 97-01	Decal, Engine Warn.
2	590 88 49-01	Decal, Deck Warn.
3	589 35 79-01	Decal, Warn. No Step
4	586 04 73-02	Decal, Tractor Saddle
5	586 97 88-01	Decal, Deflect. Warn.
8	581 58 00-01	Decal, Mower Sch.
10	587 01 51-01	Decal, Reserve Fuel Selector
14	590 51 19-01	Decal, Panel Side
15	590 50 14-01	Decal, Rep. Parts

KEY NO.	PART NO.	DESCRIPTION
16	581 62 73-01	Decal, Hood Logo
18	581 57 96-01	Decal, Chassis Hot Muffler
--	501 74 90-01	Decal, Drawbar Locking Differential
--	581 72 46-01	Decal, Drawbar
--	581 72 48-01	Decal, Bypass
--	532 43 98-82	Pad, Footrest, LH
--	532 43 98-81	Pad, Footrest, RH
--	115 88 07-80	Manual, Operator's (English)

WHEELS AND TIRES

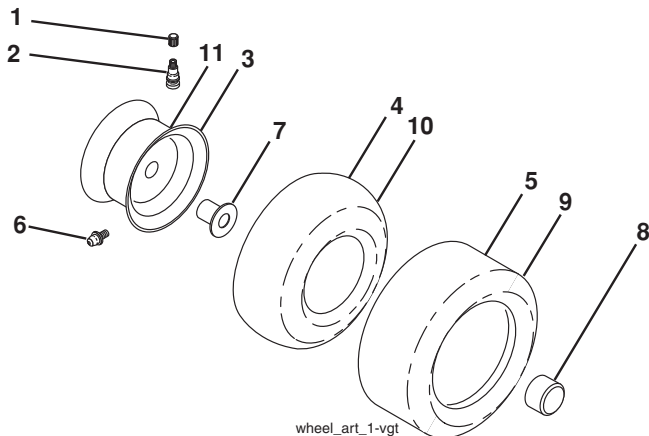

KEY NO.	PART NO.	DESCRIPTION
1	532 05 91-92	Cap, Valve, Tire
2	532 06 51-39	Stem, Valve
3	532 13 83-36	Rim Assembly, Front
4	532 05 99-04	Tube, Front (Service Item Only)
5	532 17 04-55	Tire, Front 15 x 6-6
6	532 00 02-78	Fitting, Grease (Front Wheel Only)
7	532 00 90-40	Bearing, Flange (Front Wheel Only)
8	532 17 50-39	Cap, Axle
9	532 17 04-56	Tire, Rear 20 x 10-8
10	532 00 71-52	Tube, Rear (Service Item Only)
11	532 13 83-37	Rim Assembly, Rear
--	532 14 43-34	Sealant, Tire (10 oz. Tube)

NOTE: All component dimensions given in U.S. inches
1 inch = 25.4 mm

TRACTOR - - MODEL NO. YTH2642TDF (96041040300), PRODUCT NO. 960 41 04-03 SCHEMATIC 38

SCH12

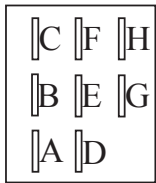
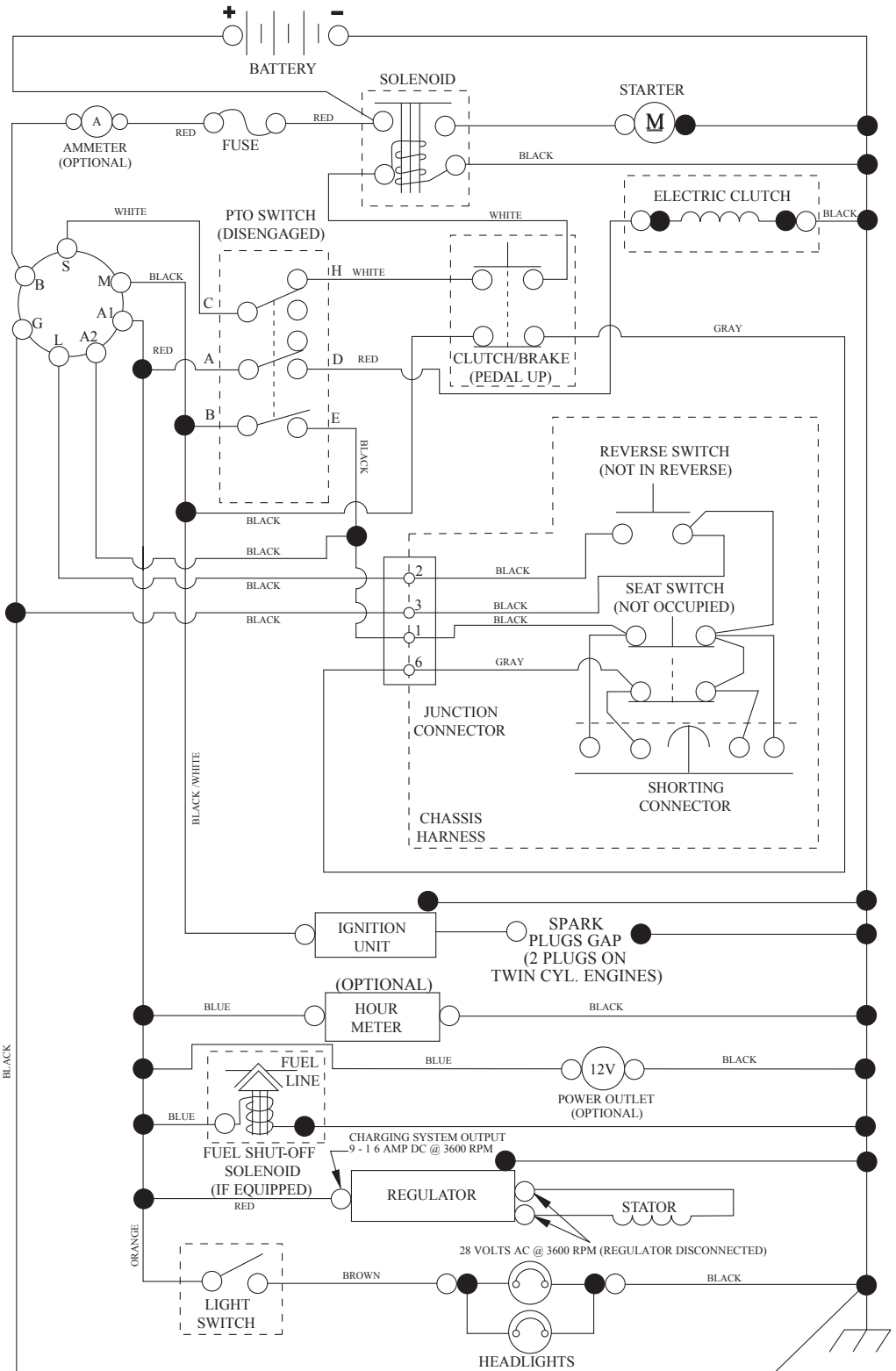

PTO SWITCH
(MATING SIDE)

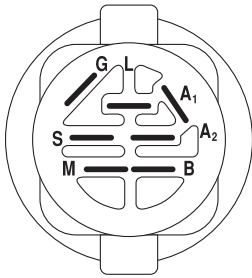

IGNITION SWITCH

POSITION	CIRCUIT	"MAKE"
OFF	M+G+A1	
RUN/OVERRIDE	B+A1	
RUN	B+A1	L+A2
START	B+S+A1	

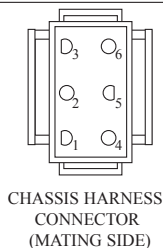

CHASSIS HARNESS
CONNECTOR
(MATING SIDE)

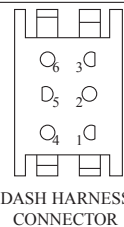

DASH HARNESS
CONNECTOR

WIRING INSULATED CLIPS
NOTE: IF WIRING INSULATED
CLIPS WERE REMOVED FOR
SERVICING OF UNIT, THEY
SHOULD BE RE-INSTALLED TO
PROPERLY SECURE YOUR
WIRING.

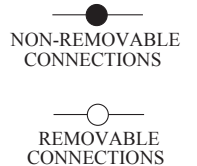

TRACTOR - - MODEL NO. YTH2642TDF (96041040300), PRODUCT NO. 960 41 04-03
ELECTRICAL **32**

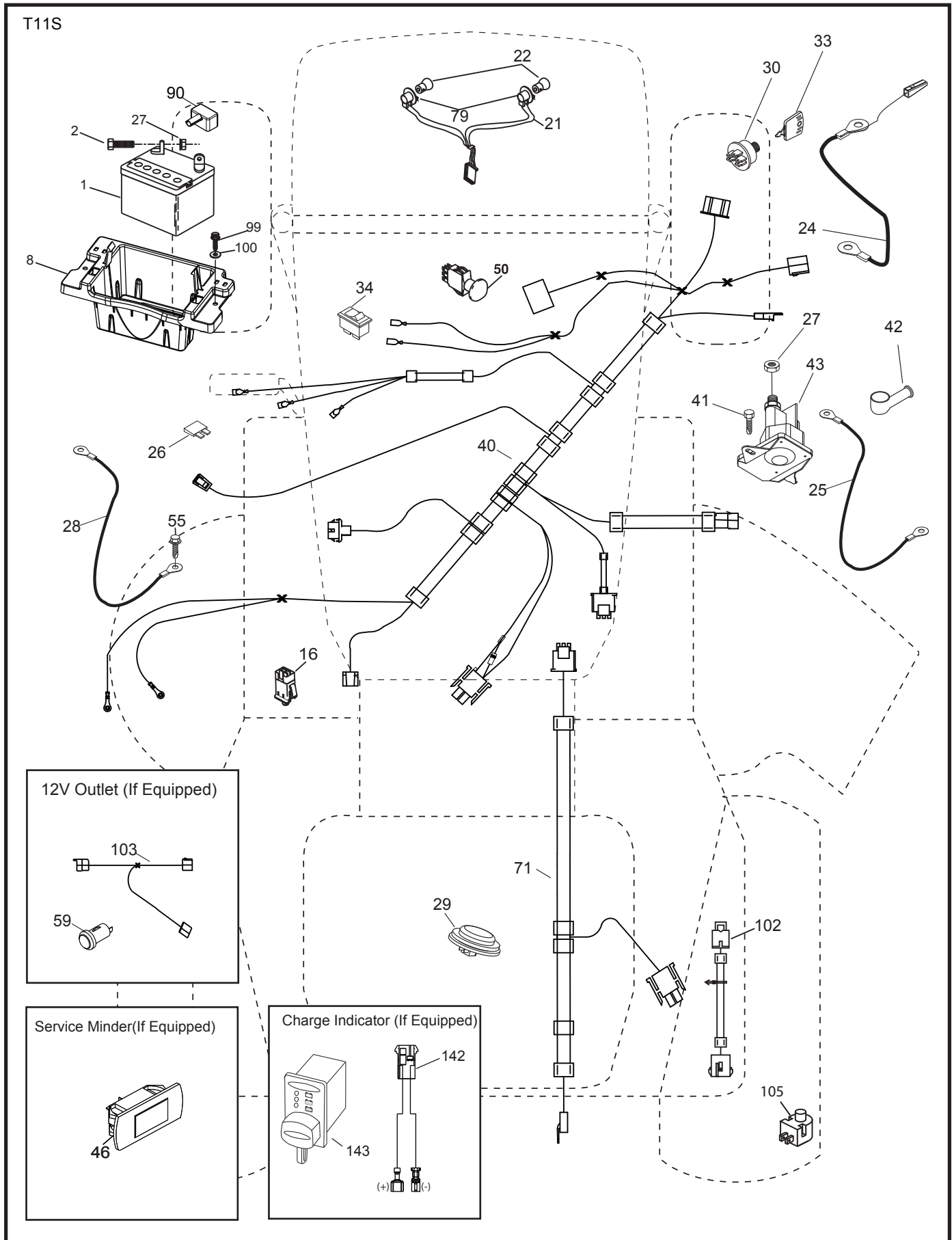

**TRACTOR - - MODEL NO. YTH2642TDF (96041040300), PRODUCT NO. 960 41 04-03
ELECTRICAL 32**

KEY NO.	PART NO.	DESCRIPTION
1	532 16 34-65	Battery
2	874 76 04-12	Bolt Hex Head 1/4-20 x 3/4
8	587 20 51-01	Box Battery
16	532 17 61-38	Switch Interlock
21	532 40 02-52	Harness Light
22	532 00 41-52	Bulb Light
24	585 55 56-01	Cable Battery
25	585 55 55-01	Cable Starter
26	532 17 51-58	Fuse
27	873 51 04-00	Nut Keps Hex 1/4-20 unc
28	532 41 65-88	Cable, Ground
29	532 40 15-45	Switch, Seat
30	532 19 33-50	Switch, Ign.
33	532 41 19-35	Key/Chain
34	532 11 07-12	Switch Light
40	501 13 29-01	Harness Ign. Dash
41	817 72 04-08	Screw Thd Cut 1/4-20 x 1/2
42	532 13 15-63	Cover, Terminal
43	582 04 28-01	Solenoid
46	594 91 91-01	Gauge Hourmeter Delta Snapin
50	582 10 76-01	Switch PTO
55	817 06 05-12	Screw 5/16-18 x 3/4
71	532 19 42-76	Harness Ign. Chassis
79	532 17 52-42	Socket Asm Bulb Twistlock
90	532 43 53-95	Cover Terminal Battery
99	817 67 04-12	Screw Hexwsh Thdrol 1/4-20 x 3/4
100	819 09 14-16	Washer 9/32 x 7/8 x 16 Ga.
102	532 40 44-54	Harness Pigtail
105	532 40 75-68	Switch Reverse TT Pedal Control

NOTE: All component dimensions given in U.S. inches
1 inch = 25.4 mm

TRACTOR - - MODEL NO. YTH2642TDF (96041040300), PRODUCT NO. 960 41 04-03
CHASSIS AND ENCLOSURES 39

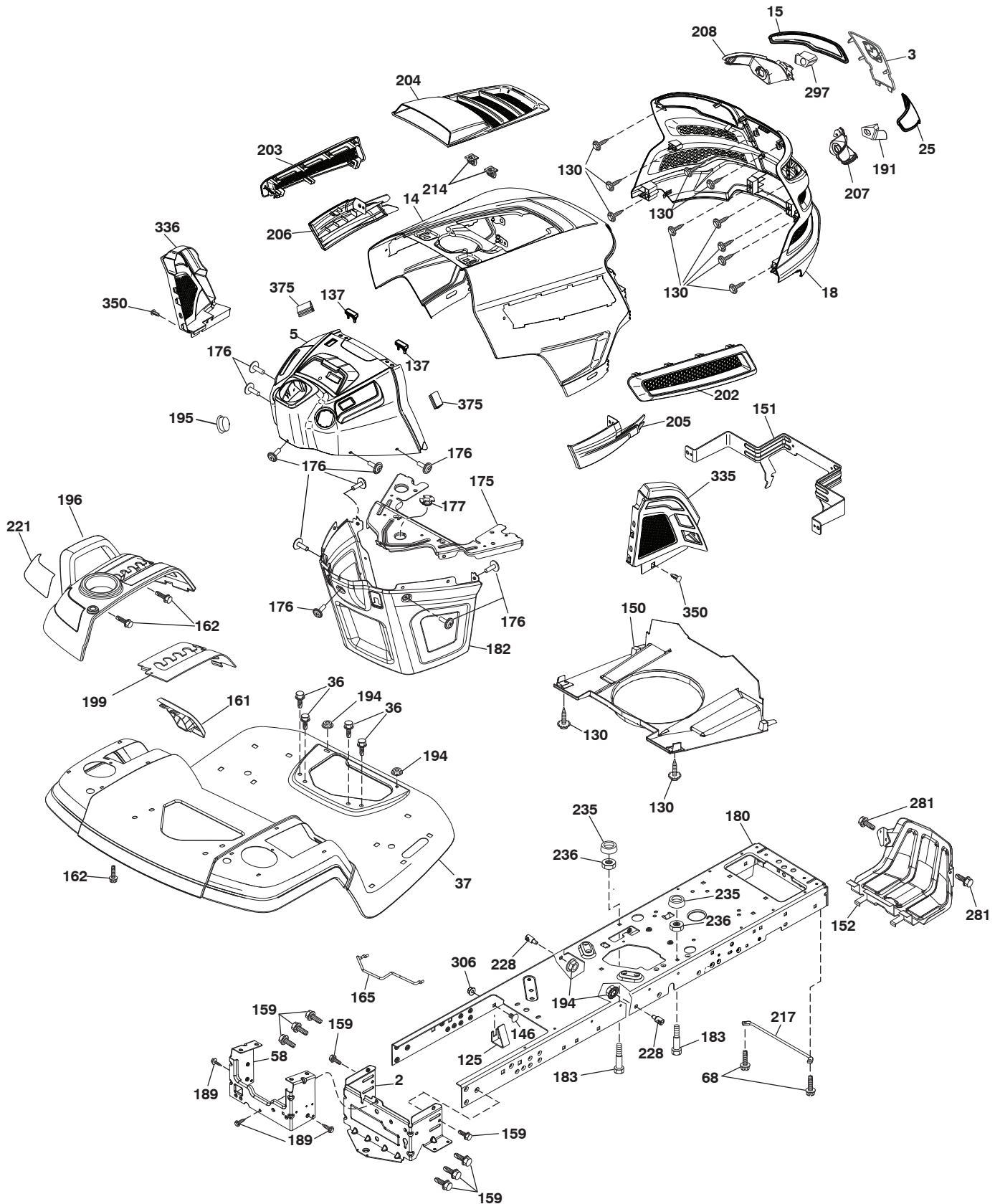

chassis-tex_GT HUSQ II_252_r2

**TRACTOR - - MODEL NO. YTH2642TDF (96041040300), PRODUCT NO. 960 41 04-03
CHASSIS AND ENCLOSURES 39**

KEY NO.	PART NO.	DESCRIPTION	KEY NO.	PART NO.	DESCRIPTION
2	532 41 22-82	Drawbar Lower	191	532 43 74-55	Insert Reflective RH
3	532 44 44-81	Applique	194	873 90 05-00	Nut Lock Hex Flange 5/16-18
5	590 74 88-11	Dash	195	532 40 41-37	Plug Hole Dash
14	532 44 11-77	Hood	196	532 43 97-16	Console Deck Lift
15	532 43 97-33	Lens LH	199	532 19 82-59	Plate Deck Lift
18	587 52 34-01	Grille	202	532 43 97-28	Vent Side Hood RH
25	532 44 33-85	Lens RH	203	532 43 97-27	Vent Side Hood LH
36	817 06 05-12	Screw 5/16-18 x 3/4	204	532 43 57-14	Vent Top Hood
37	532 44 12-08	Fender	205	532 43 97-30	Trim Hood Side RH
58	532 41 22-81	Drawbar Upper	206	532 43 97-29	Trim Hood Side LH
68	539 99 08-58	Screw Thdrol 5/16-18 x 1/2	207	587 46 48-01	Bezel RH
125	581 68 48-01	Clip Fuel Line	208	587 46 45-01	Bezel LH
130	532 41 63-58	Screw 10 x .750 BOS Thread	214	532 19 91-45	Clip Retainer Tinner
137	532 40 75-90	Bumper Dash	217	532 40 91-67	Rod Pivot
146	581 85 79-01	Bolt	221	532 19 89-09	Reflector LH
150	532 43 97-74	Air Duct	228	532 19 51-61	Stud Fastner
151	532 43 66-70	Bracket Pivot Hood	235	532 40 61-29	Spacer Fender
152	532 43 98-70	Shield Browning	236	873 93 05-00	Nut Lock 5/16-18 unc
159	817 00 06-12	Screw 3/8-16 x 3/4	281	817 00 06-16	Screw 3/8-16 x 1 Sgml
161	532 43 99-29	Window, Fuel	297	532 43 74-56	Insert Reflective LH
162	532 14 24-32	Screw Hex Wsh 1/4 x 1/2 unc	306	873 90 06-00	Nut Lock
165	532 19 43-30	Support Tank Rear	335	532 44 82-04	Cover RH Lower Close Out
175	590 60 77-02	Crossmember	336	532 44 53-09	Cover LH Lower Close Out
176	532 40 07-76	Screw 10-24 x 5/8	350	532 44 51-43	Clip X-mas Tree
177	532 19 52-28	Bushing Steering	375	586 90 82-01	Dash Clip-On Bumper
180	593 34 63-02	Chassis	--	532 40 09-44	Bumper
182	532 40 68-59	Dash Lower			
183	874 52 05-20	Bolt 5/16-18 x1-1/4			
189	817 00 05-12	Screw 5/16-18 x 3/4			

NOTE: All component dimensions given in U.S. inches
1 inch = 25.4 mm

TRACTOR - - MODEL NO. YTH2642TDF (96041040300), PRODUCT NO. 960 41 04-03
DRIVE **40**

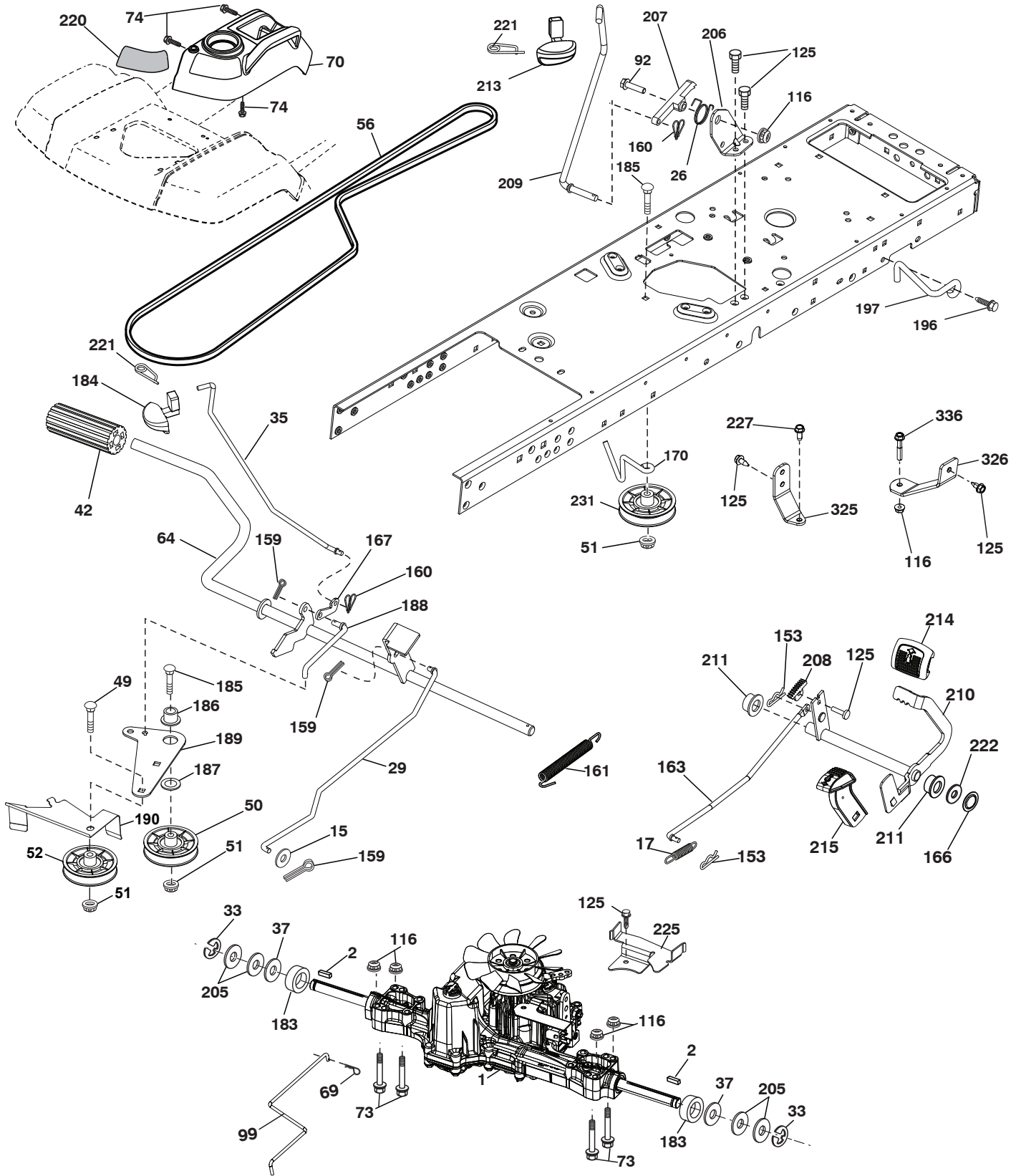

drive-tex_K46_pedal_204

**TRACTOR - - MODEL NO. YTH2642TDF (96041040300), PRODUCT NO. 960 41 04-03
DRIVE **40****

KEY NO.	PART NO.	DESCRIPTION	KEY NO.	PART NO.	DESCRIPTION
1	---	Transaxle, TUFFTORQ K46CR (501051401) (Order parts from transaxle manufacturer.)	184	587 65 37-01	Handle Parking Brake
2	532 12 35-83	Key	185	872 11 06-22	Bolt Rdhd Sqnk 3/8-16 x 2-1/2
15	819 13 13-16	Washer 13/32 x 13/16 x 16 Ga.	186	532 19 43-21	Spacer Retainer
17	532 41 36-78	Spring, Brake	187	819 13 32-10	Washer
26	532 19 96-79	Spring Return Cruise	188	582 21 70-01	Link Clutch Ground Drive, Long
29	532 40 38-06	Rod, Brake	189	532 19 43-17	Bellcrank Ground Drive
33	812 00 00-01	Ring E	190	532 19 43-18	Keeper Bellcrank Ground Drive
35	583 86 45-02	Rod, Brake, Park	196	817 00 06-16	Screw 3/8-16 x 1
37	532 18 89-67	Washer Hardened	197	587 40 20-01	Bracket Clutch Anti-Rotation
42	532 00 88-83	Cover, Foot Pedal	205	532 12 17-48	Washer
49	872 11 06-14	Bolt	206	532 44 85-96	Bracket Mount Latch Cruise
50	532 19 43-27	Pulley Idler Flat	207	587 03 14-01	Latch Control Cruise
51	873 90 06-00	Lock Nut 3/8-16	208	532 19 78-69	Gear Sector Control Cruise
52	532 19 43-26	Idler V-Groove	209	532 19 95-92	Rod Control Cruise
56	592 85 52-01	V-Belt, Drive	210	532 19 78-60	Rocker Asm. Pedal Control
64	532 19 78-65	Shaft Asm. Pedal Brake Control	211	532 12 01-83	Bearing Nylon
69	532 42 33-03	Hairpin Soft Zink .059 x 1.125	213	532 40 31-19	Knob Control Cruise
70	532 43 96-61	Console Shift	214	532 41 12-63	Pedal Forward
73	874 49 05-40	Bolt Hex Flghd 5/16-18 x 2-1/2 Gr. 5	215	586 60 65-02	Pedal Reverse
74	532 14 24-32	Screw Hex Wsh. Hi-Lo 1/4 x 1/2 unc	220	532 19 89-08	Reflector RH
92	874 76 05-20	Bolt Fin Hex 5/16-18 unc x 1.25	221	532 40 31-87	Retainer Spring Clip Handle
99	582 40 45-01	Rod Spring Bypass	222	879 21 20-10	Washer 21/32 x 1-1/4 x 10 Ga.
116	873 90 05-00	Nut Lock Hex Flange 5/16-18	225	532 40 33-19	Keeper Belt Trans.
125	817 00 05-12	Screw 5/16-18 x 3/4	227	817 49 05-12	Screw Thdrol 5/16-18 x 3/4
153	532 00 44-97	Retainer Spring	231	532 40 72-87	Idler V-Groove
159	876 02 04-12	Pin Cotter 1/8 x 3/4	325	586 43 12-02	Torque Strap K46 LT RH
160	532 16 94-84	Retainer Clip	326	586 00 11-02	Bracket Trq Stp 46 20" Tire RH
161	532 10 57-09	Spring, Return, Clutch	336	587 25 96-01	Bolt 5/16-18 x 1-3/4 Flanged
163	532 44 82-75	Rod Pedal Control			
166	532 42 91-64	Nut Push			
167	532 40 52-57	Latch Brake Parking			
170	532 41 34-30	Keeper Belt Centerspan			
183	532 13 70-57	Spacer Split			

NOTE: All component dimensions given in U.S. inches
1 inch = 25.4 mm

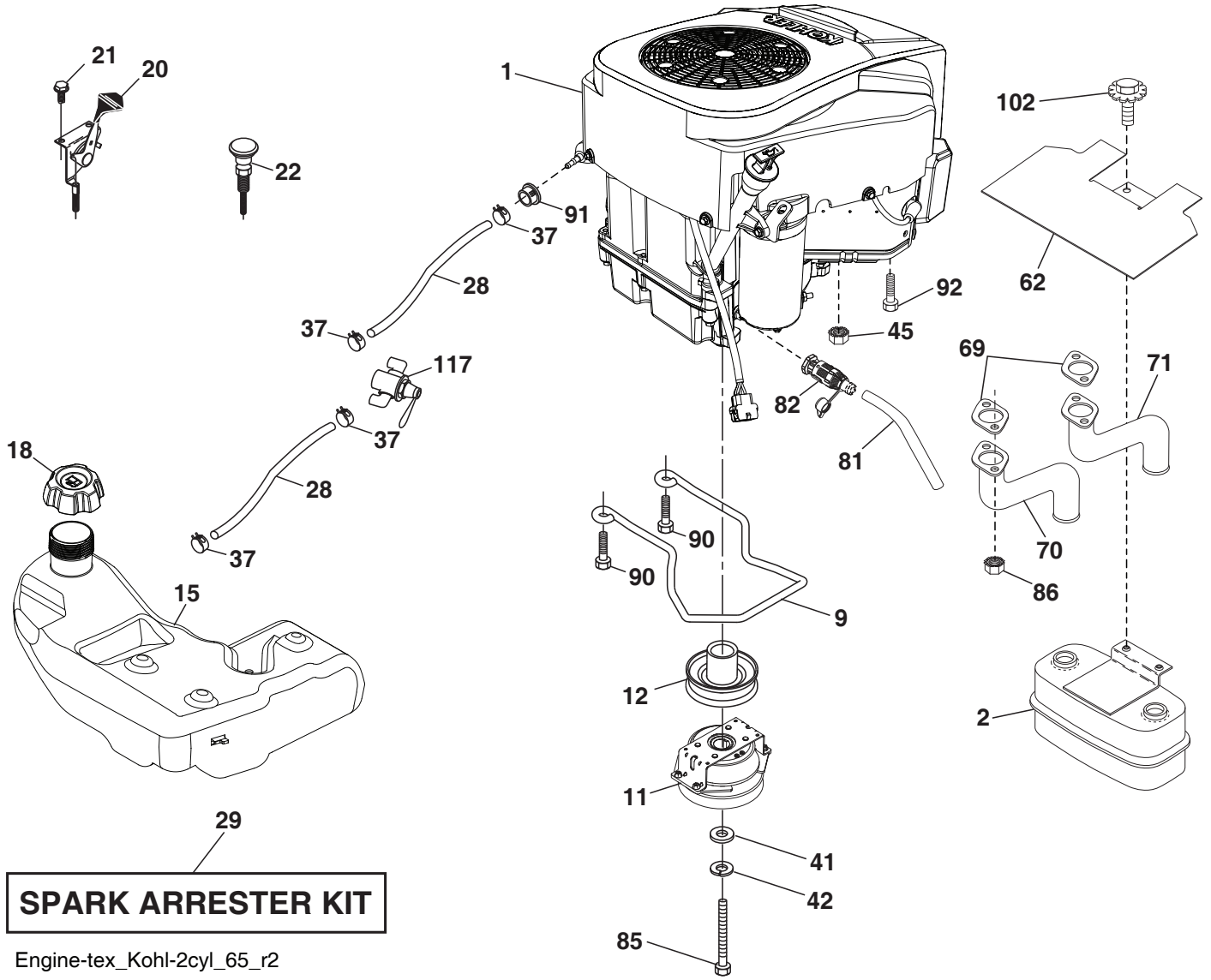

**TRACTOR - - MODEL NO. YTH2642TDF (96041040300), PRODUCT NO. 960 41 04-03
ENGINE 24**

KEY PART NO. NO.	DESCRIPTION
1 - - - - -	Engine Kohl Model No. KT745-3054 (588076401) (Order parts from engine manufacturer.)
2 589 81 87-01	Muffler
9 501 83 26-02	Keeper Belt Engine
11 587 25 50-01	Clutch Electric
12 586 89 96-01	Pulley Engine
15 532 42 28-04	Tank Fuel
18 584 24 87-02	Cap
20 532 18 29-37	Control Throttle
21 532 41 63-58	Screw #10 x .750 BOS Thread
22 532 19 15-96	Control Choke
28 587 04 46-60	Fuel Line
29 532 13 71-80	Spark Arrester Kit
37 532 12 34-87	Clamp Hose
41 532 12 61-97	Washer 1-1/2 OD x 15/32
42 539 99 02-47	Washer Lock 7/16
45 873 51 04-00	Nut Keps Hex 1/4-20 unc
62 532 43 40-17	Heat Shield
69 532 18 60-54	Gasket
70 583 95 45-01	Tube Exhaust LH
71 583 95 48-01	Exhaust Tube RH
81 532 14 84-56	Tube Drain Oil Easy
82 532 42 82-87	Valve Oil Drain
85 501 60 67-01	Bolt Hex 7/16-20 x 5 Gr. 5
86 532 18 43-62	Nut.Hex.Flange
90 817 00 06-16	Screw 3/8-16 x 1
91 532 18 74-95	Bushing 1.375 OD
92 817 12 06-16	Screw 3/8-16 x 1
102 817 00 05-12	Screw 5/16 x 3/4
117 532 42 08-28	Valve Fuel Reserve

NOTE: All component dimensions given in U.S. inches
1 inch = 25.4 mm

TRACTOR - - MODEL NO. YTH2642TDF (96041040300), PRODUCT NO. 960 41 04-03
 STEERING ASSEMBLY **41**

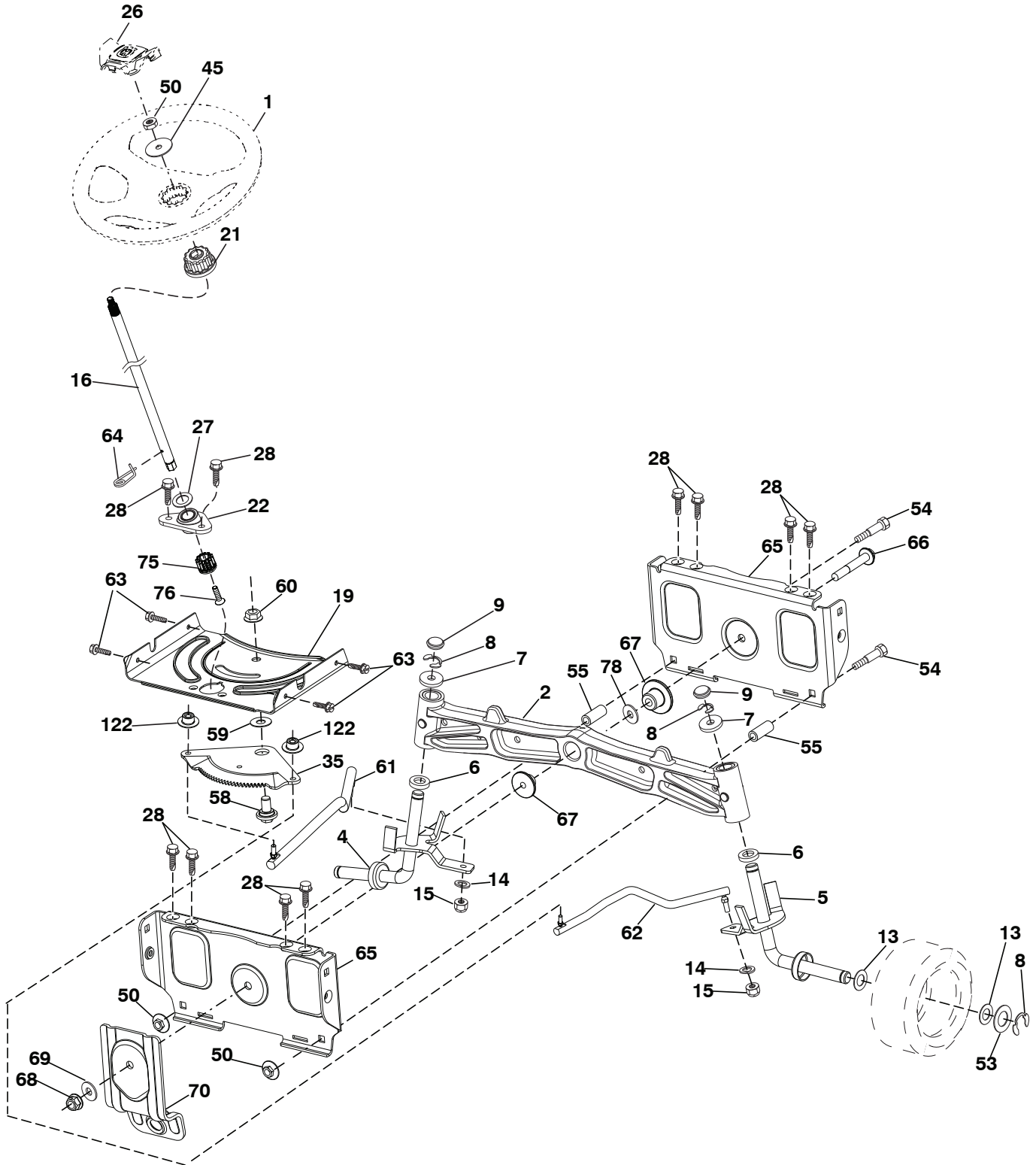

steering-tex_HUSQSR_63_r1

**TRACTOR - - MODEL NO. YTH2642TDF (96041040300), PRODUCT NO. 960 41 04-03
STEERING ASSEMBLY **41****

KEY NO.	PART NO.	DESCRIPTION
1	532 43 97-40	Wheel, Steering
2	532 19 59-68	Axle Asm., Front
4	586 72 40-01	Spindle Asm., LH
5	586 72 41-01	Spindle Asm., RH
6	532 00 62-66	Washer, Thrust .75 x 1.230
7	532 12 17-48	Washer 25/32 x 1-5/8 x 16 Ga.
8	812 00 00-29	Ring, Clip #T5304-75
9	532 12 12-32	Cap, Spindle
13	532 12 17-49	Washer 25/32 x 1-1/4 x 16 Ga.
14	539 99 01-18	Washer, Lock 3/8
15	873 54 06-00	Nut, Crown Lock 3/8-24 unf
16	587 01 60-02	Steering Shaft
19	532 19 47-29	Plate Steering
21	586 84 02-01	Adapter Wheel Steering
22	585 02 98-02	Bearing
26	532 43 97-43	Insert, Wheel Steering
27	819 21 16-16	Washer
28	817 00 06-12	Screw 3/8-16 x 3/4
35	532 19 47-32	Gear, Sector Plate
45	587 01 64-01	Washer 3/8 ID 2-3/8 OD 12 Ga. PLTD
50	873 90 06-00	Nut Lock Flg 3/8-16 unc
53	532 18 89-67	Washer Hardened .793 x 1.637 x .060
54	874 76 06-36	Bolt Hex 3/8-16 unc x 2-1/4
55	532 41 47-36	Spacer Brace Axle
58	532 19 47-47	Bolt Shoulder Sector Pivot CFM
59	532 19 47-48	Washer Thrust Sector Steering
60	873 97 10-00	Nut Flange Lock 5/8-11
61	588 79 44-02	Draglink, LH
62	588 79 45-02	Draglink, RH
63	817 00 05-12	Screw 5/16-18 x 3/4
64	532 19 98-49	Retainer Clip Spring Steering
65	532 19 47-34	Brace Axle Front
66	871 02 07-48	Bolt Hex Fghd 7/16-14 x 3 Serr
67	532 19 47-37	Bushing PM Front Axle
68	873 90 07-00	Nut Lock Flange 7/16-14 Gr. 5
69	532 19 91-62	Washer 1.5 x .505 x .118
70	585 33 88-01	Bracket Deck Susp. Front
75	580 68 37-01	Pinion
76	580 68 36-01	Screw Head Sock
78	532 05 70-79	Washer Thrust
122	532 44 49-62	Cap Gear

NOTE: All component dimensions given in U.S. inches
1 inch = 25.4 mm

TRACTOR - - MODEL NO. YTH2642TDF (96041040300), PRODUCT NO. 960 41 04-03
MOWER DECK **44**

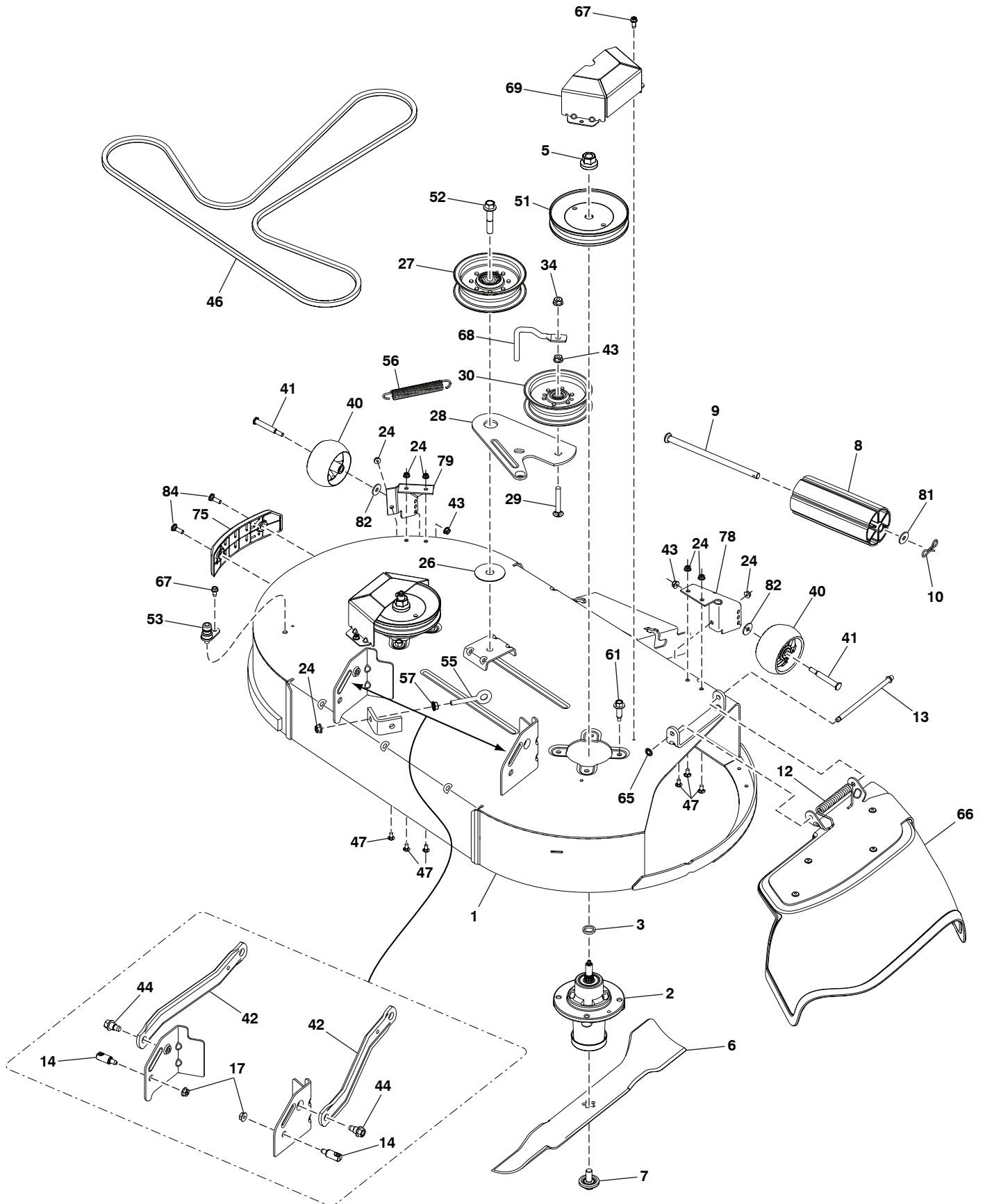

Mower Deck-tex_42F Flat_elec_7_r3

**TRACTOR - - MODEL NO. YTH2642TDF (96041040300), PRODUCT NO. 960 41 04-03
MOWER DECK 44**

KEY NO.	PART NO.	DESCRIPTION
1	587 93 90-01	Kit, SVC, Weldment
2	539 11 21-70	Housing Assembly
3	532 18 76-90	Washer-Spacer
5	532 40 02-34	Nut Lock Flange Top
6	586 91 81-01	Blade
7	532 19 30-03	Bolt/Washer Asm 7/16-20 unf
8	532 17 60-66	Roller, Nose
9	532 17 91-27	Rod, Roller, Nose
10	539 19 42-08	Clip Retainer
12	587 35 47-01	Spring
13	532 13 14-91	Rod Hinge 42/46/48/54
14	532 19 51-61	Stud, Fasten w/ Anti- Rotate
17	873 90 05-00	Nut Lock Hex Flanged 5/16-18
24	539 11 28-99	Nut 5/16-18 Hex Flange Nyloc
26	532 17 85-15	Washer, Flat Hardened
27	532 19 61-04	Pulley, Idler Spec. Hub
28	586 87 40-02	Arm 42 FCS
29	539 12 81-01	Bolt 3/8-16
30	532 19 61-06	Pulley, Idler
34	873 68 06-00	Nut Crownlock 3/8-16 unc
40	589 52 73-01	Gauge Wheel
41	532 19 34-06	Bolt Shoulder
42	587 14 05-02	Arm Susp. Rear
43	873 90 06-00	Nut Lock FLG 3/8-16 unc
44	532 19 65-39	Bolt Shoulder
46	587 27 01-01	Belt 42 FCS
47	539 99 03-16	RHSNB 5/16-18 x 3/4 Gr. 5 ZD
51	532 19 97-91	Pulley, Mandrel
52	588 43 83-01	Screw 7/16-14 x 2.125 Hex Wsh Hd
53	532 41 55-98	Washout Port
55	539 11 55-74	Eyebolt 5/16 x 3-1/2
56	587 35 84-01	Spring
57	539 99 05-85	Nut 5/16-18 Hex
61	584 95 39-01	Bolt Hex Wsh Hd 3/8-18 x 1.19
65	532 11 04-52	Nut Push Phos & Oil
66	587 30 57-01	Deflector Assy. 42 FCS
67	532 13 77-29	Screw
68	532 19 84-68	Keeper Belt Idler
69	586 93 68-02	Cover 42" Mandrel
75	582 68 32-03	Bumper
78	501 80 83-02	Gauge Wheel Bracket RH
79	590 43 90-02	Gauge Wheel Bracket LH
81	582 36 05-01	Bushing Nose Roller
82	819 12 14-14	Washer 5/16 Flat
84	532 17 01-65	Bolt Shoulder 5/16-18
--	590 52 08-01	Mower Deck Complete

NOTE: All component dimensions given in U.S. inches
1 inch = 25.4 mm

**TRACTOR - - MODEL NO. YTH2642TDF (96041040300), PRODUCT NO. 960 41 04-03
MOWER LIFT **45****

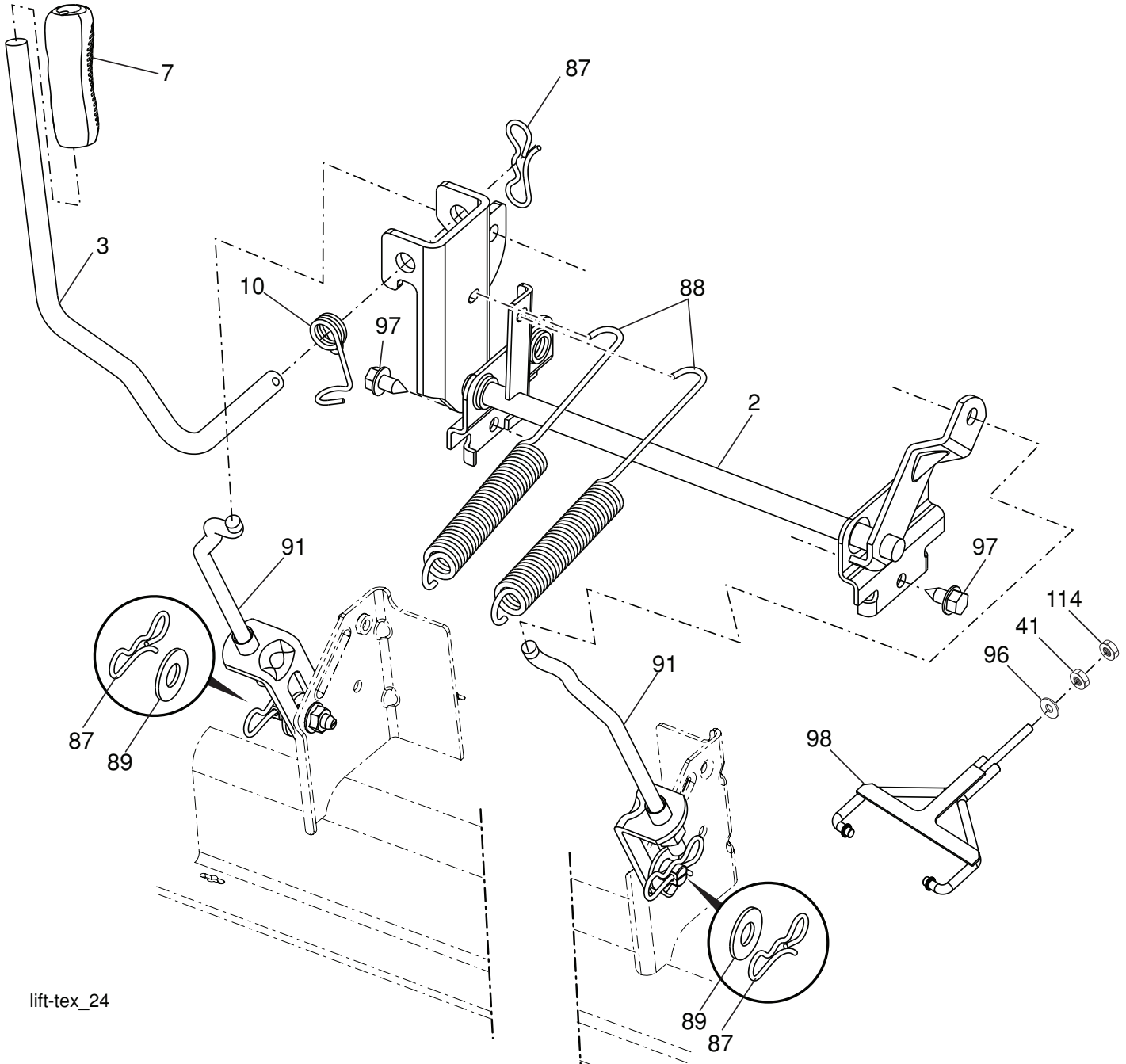

lift-tex_24

KEY PART NO.	PART NO.	DESCRIPTION
2	532 42 20-27	Shaft Asm., Lift
3	532 19 52-30	Lever Asm., Lift RH
7	580 96 23-01	Grip, Lever
10	532 19 63-14	Spring Torsion
41	532 17 59-94	Nut, Lift Link
87	532 19 42-09	Pin Cotter 7/16 Bow Tie Lock
88	532 41 07-10	Spring Lift Assist
89	819 19 19-12	Washer Clear Zinc

KEY PART NO.	PART NO.	DESCRIPTION
91	532 40 34-07	Link Lift Susp Mower Rear
96	532 19 52-63	Bushing, Spherical
97	817 00 06-12	Screw 3/8-16 x .75
98	574 82 25-01	Link Lift Susp. Front Mower
114	873 36 07-00	Nut Jam 7/16-20

NOTE: All component dimensions given in U.S. inches
1 inch = 25.4 mm

**TRACTOR - - MODEL NO. YTH2642TDF (96041040300), PRODUCT NO. 960 41 04-03
SEAT ASSEMBLY 42**

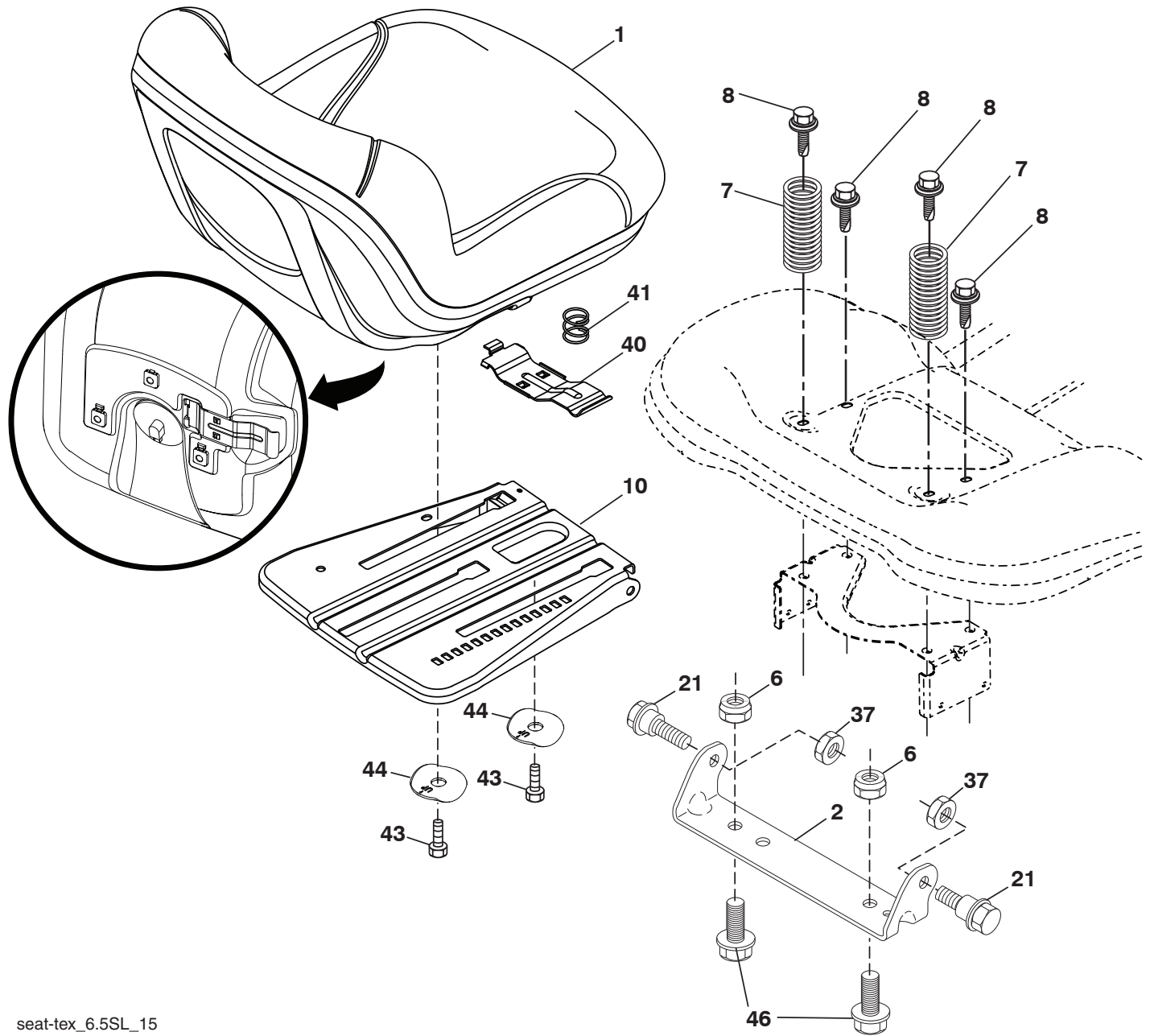

seat-tex_6.5SL_15

KEY NO.	PART NO.	DESCRIPTION
1	532 43 98-22	Seat
2	532 18 01-66	Bracket Pivot Fender
6	873 80 06-00	Nut, Lock W/Ins. 3/8-16 unc
7	589 48 35-01	Spring, Seat Cprsn
8	532 17 18-77	Bolt 5/16-18 unc x 3/4 w/Sems
10	596 65 74-02	Plate, Seat
21	587 90 78-01	Bolt, Shoulder 5/16-18 x 5/8
37	873 80 05-00	Nut, Lock 5/16-18 unc

KEY NO.	PART NO.	DESCRIPTION
40	532 19 76-61	Handle Slide Seat
41	532 19 82-00	Spring Latch Seat
43	874 76 06-12	Bolt Fin Hex 3/8-16 unc x 3/4
44	501 05 18-01	Washer Winged
46	588 09 04-01	Bolt 3/8-16 x 1, 1.25

NOTE: All component dimensions given in U.S. inches
1 inch = 25.4 mm

