

ILLUSTRATED PARTS LIST

MODEL NUMBER ST 224

PRODUCT NUMBER 961 91 00-87

MFG. ID. NUMBER 96191008704

REPAIR PARTS

AUGER HOUSING / IMPELLER ASSEMBLY

SNOW THROWER - MODEL NO. ST 224 (96191008704), PRODUCT NO. 961 91 00-87

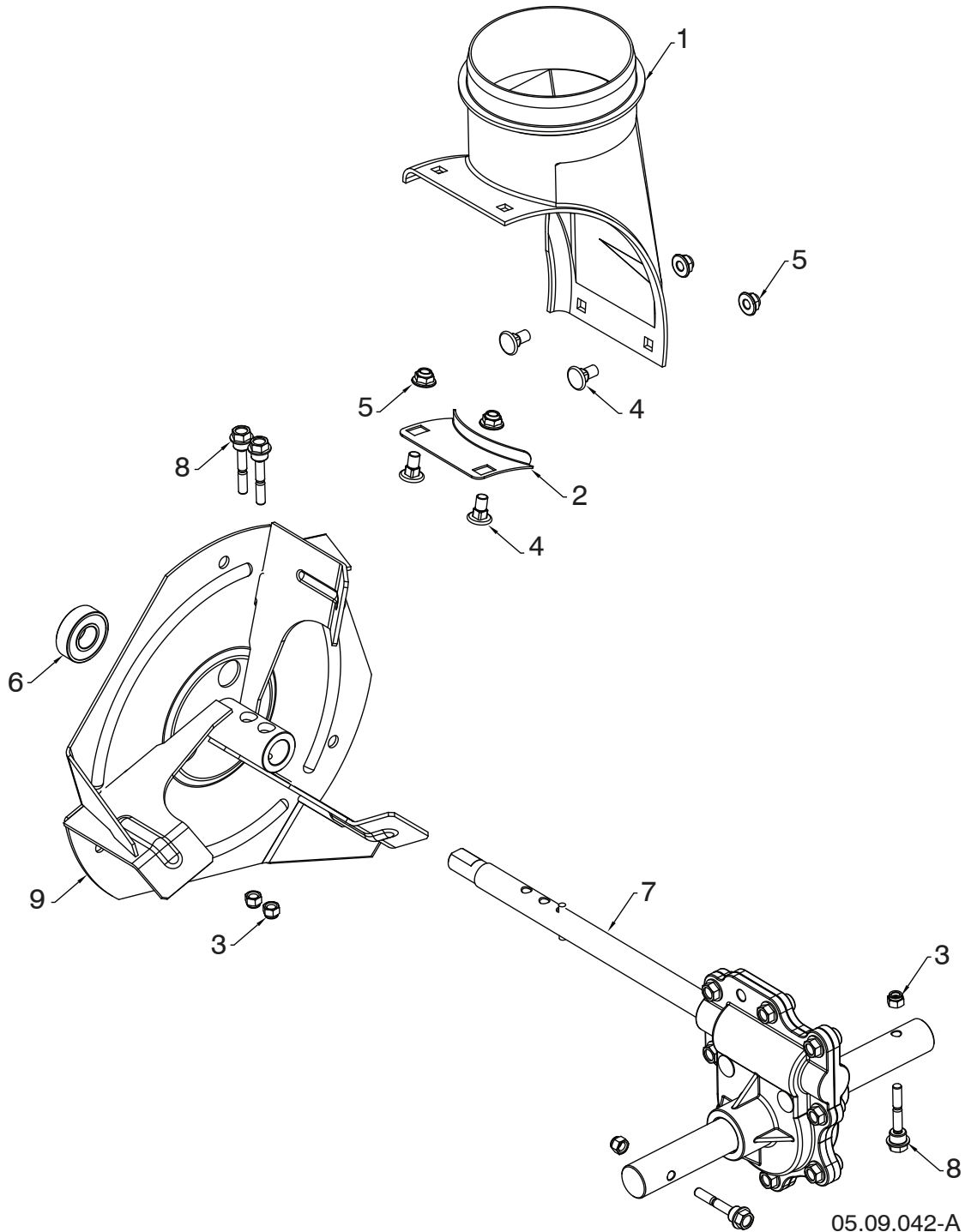

NOTE: All component dimensions given in U.S. inches. 1 inch = 25.4 mm
IMPORTANT: Use only Original Equipment Manufacturer (O.E.M.) replacement parts. Failure to do so could be hazardous, damage your snow thrower and void your warranty.

REPAIR PARTS**AUGER HOUSING / IMPELLER ASSEMBLY****SNOW THROWER - MODEL NO. ST 224 (96191008704), PRODUCT NO. 961 91 00-87**

KEY NO.	PART NO.	DESCRIPTION
1	585 05 69-01	CHUTE DISCHARGE BASE
2	532 18 40-95	BRACKET CORNER DISCHARGE YZP
3	873 80 04-00	NUT NYLOCK 1/4 - 20
4	585 69 12-01	BOLT CAR WAF BLK 5/16-18 X .488
5	585 69 13-01	NUT HEX FLANGE 5/16-18 NYLOCK
6	532 19 87-91	BEARING 1501389 BALL
7	582 86 76-01	TRANSMISSION GEARBOX ALUM DD
8	588 07 75-01	BOLT 1/4-20 X 1-13/16 SHEAR
9	586 60 72-02	IMPELLER STEEL SNOW 479

NOTE: All component dimensions given in U.S. inches. 1 inch = 25.4 mm
IMPORTANT: Use only Original Equipment Manufacturer (O.E.M.) replacement parts.
Failure to do so could be hazardous, damage your snow thrower and void your warranty.

REPAIR PARTS

AUGER HOUSING / IMPELLER ASSEMBLY

SNOW THROWER - MODEL NO. ST 224 (96191008704), PRODUCT NO. 961 91 00-87

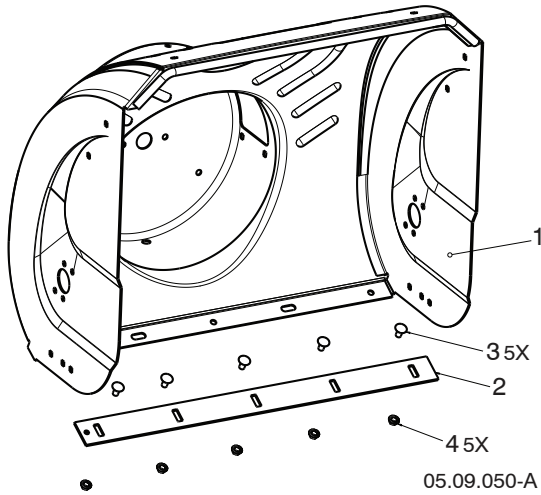

KEY NO.	PART NO.	DESCRIPTION
1	593 87 29-02	AUGER HOUSING
2	532 40 78-25	SCRAPER BAR
3	872 27 05-05	CARRIAGE BOLT 5/16-18 X .625 GR5
4	532 15 53-77	NUT 5/16-18

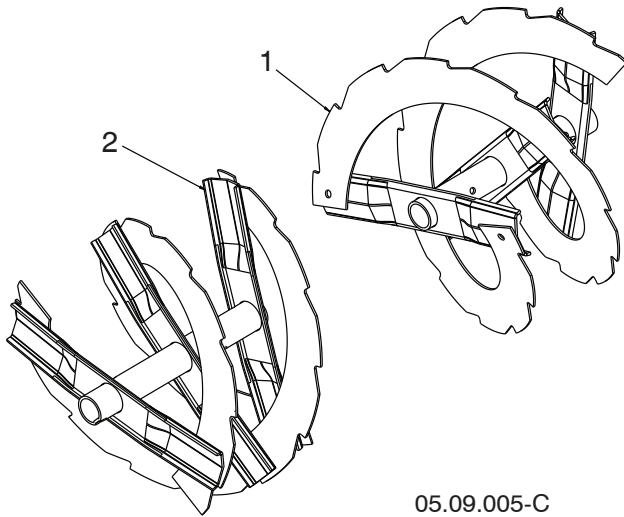

KEY NO.	PART NO.	DESCRIPTION
1	587 19 10-01	AUGER WELD RIB LH 24
2	585 54 42-01	AUGER WELD RIB RH 24

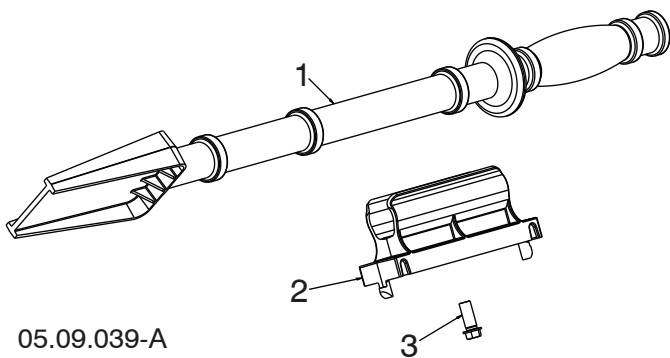

KEY NO.	PART NO.	DESCRIPTION
1	532 19 21-99	TOOL CLEANOUT
2	532 40 54-00	CLIP CLEANOUT TOOL
3	532 19 41-89	SCREW HEX WASHER 13-16 X 5/8

NOTE: All component dimensions given in U.S. inches. 1 inch = 25.4 mm
IMPORTANT: Use only Original Equipment Manufacturer (O.E.M.) replacement parts. Failure to do so could be hazardous, damage your snow thrower and void your warranty.

REPAIR PARTS

AUGER HOUSING / IMPELLER ASSEMBLY

SNOW THROWER - MODEL NO. ST 224 (96191008704), PRODUCT NO. 961 91 00-87

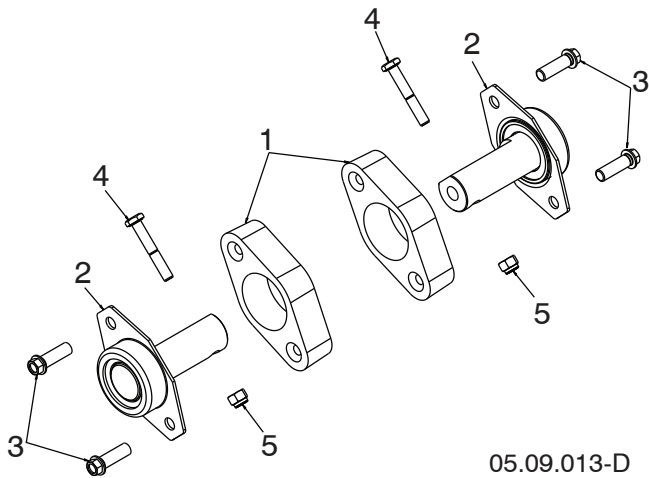

KEY NO.	PART NO.	DESCRIPTION
1	532 18 81-70	PLASTIC RETAINER
2	532 42 77-62	AUGER BALL BEARING
3	584 29 94-01	SCREW HI-LO 5/16-14 X 1.00 - BLK
4	874 78 04-26	BOLT SHEAR HEX HD 1/4-20
5	873 80 04-00	NUT 1/4-20

05.09.013-D

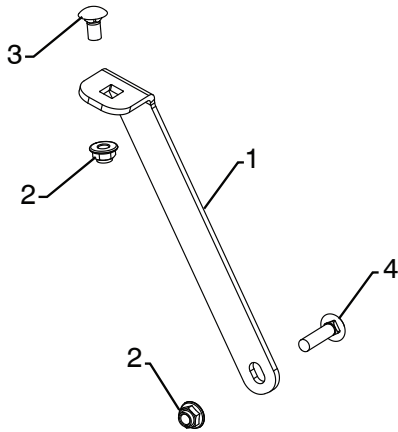

KEY NO.	PART NO.	DESCRIPTION
1	589 32 30-02	SUPPORT GEARBOX LS
2	585 69 13-01	NUT HEX FLG NYLOCK BLK 5/16-18
3	585 83 20-01	BOLT CARRIAGE BLK 5/16-18 X 5/8 BLK
4	872 11 05-10	BOLT CARRIAGE 5/16-18 X 1-1/4

05.09.049-A

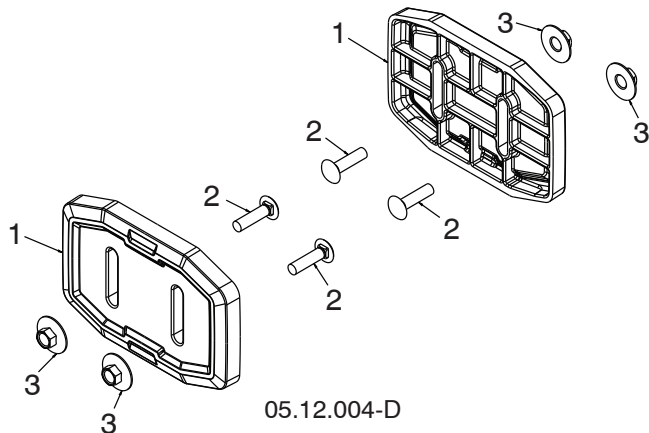

KEY NO.	PART NO.	DESCRIPTION
1	583 83 88-01	SKID SHOW UHMW
2	585 80 29-01	BOLT CARR BLK 5/16-18 X 1.25
3	585 80 28-01	NUT HEX 5/16-18 LRG FLG

05.12.004-D

NOTE: All component dimensions given in U.S. inches. 1 inch = 25.4 mm
IMPORTANT: Use only Original Equipment Manufacturer (O.E.M.) replacement parts. Failure to do so could be hazardous, damage your snow thrower and void your warranty.

REPAIR PARTS

CONTROL PANEL / DISCHARGE CHUTE

SNOW THROWER - MODEL NO. ST 224 (96191008704), PRODUCT NO. 961 91 00-87

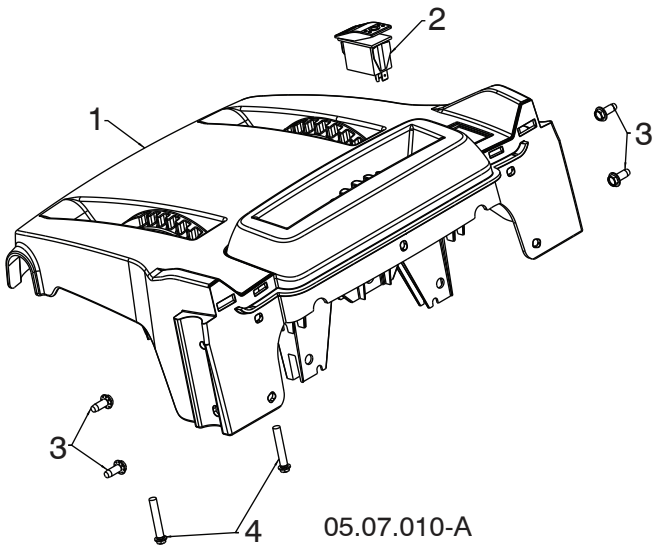

KEY NO.	PART NO.	DESCRIPTION
1	581 13 12-04	CONSOLE BASE MULTICONT W/SWITCH
2	585 80 50-01	SWITCH GRIP HEATED BLACK
3	817 06 04-10	SCREW TA SEMI GIMLE 1/4-20 X .62
4	581 32 95-01	SCREW HEX WASHER 13-16 X 1.50

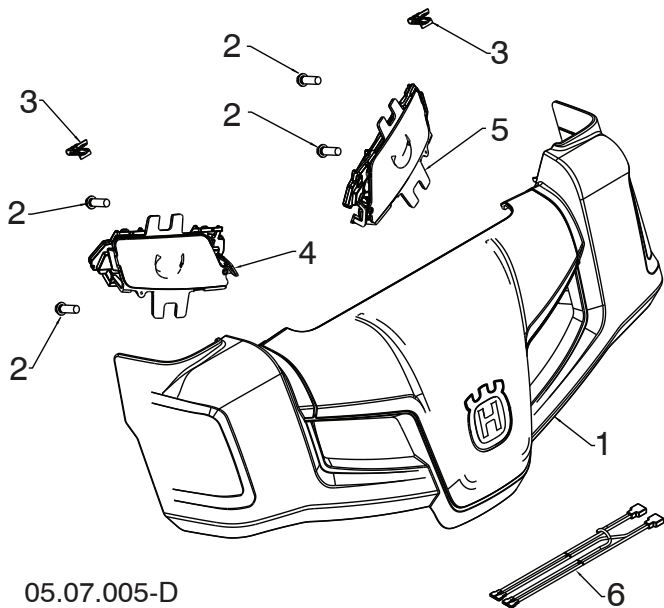

KEY NO.	PART NO.	DESCRIPTION
1	581 12 79-01	HUSQVARNA CONSOLE COVER ASM
2	532 19 41-89	SCREW HI-LO 13-16 X 5/8
3	581 92 87-01	CLIP PANEL
4	586 72 35-01	LIGHT ASM LED HUSQ RH
5	586 72 36-01	LIGHT ASM LED HUSQ LH
6	585 86 83-01	WIRE HARNESS LIGHT JUMPER

NOTE: All component dimensions given in U.S. inches. 1 inch = 25.4 mm
IMPORTANT: Use only Original Equipment Manufacturer (O.E.M.) replacement parts. Failure to do so could be hazardous, damage your snow thrower and void your warranty.

REPAIR PARTS

CONTROL PANEL / DISCHARGE CHUTE

SNOW THROWER - MODEL NO. ST 224 (96191008704), PRODUCT NO. 961 91 00-87

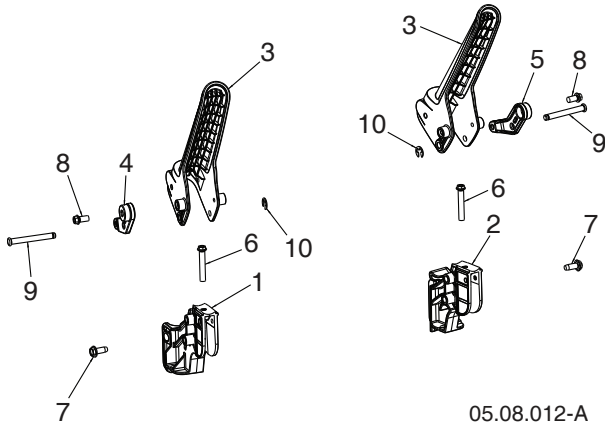

05.08.012-A

KEY NO.	PART NO.	DESCRIPTION
1	587 73 96-01	PIVOT, HANDLE LEVER - LHS
2	587 73 96-02	PIVOT, HANDLE LEVER - RHS
3	587 46 30-01	LEVER, CONTROL
4	587 73 97-01	LEVER, CABLE ARM - LHS
5	587 73 97-02	LEVER, CABLE ARM - RHS
6	581 32 95-01	SCREW HI-LO 13-16 X 1.50
7	817 06 04-10	SCREW 1/4-20 X .625
8	817 41 13-08	SCREW HI-LW 13-16 X .500
9	588 14 77-01	PIN, GROOVED
10	812 00 00-14	E-RING

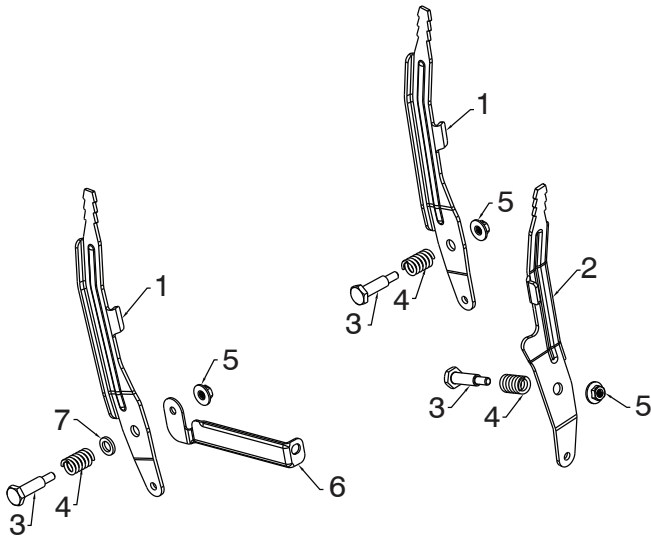

05.08.005-C

KEY NO.	PART NO.	DESCRIPTION
1	581 12 39-02	LEVER CONTROL SPEED/DEFL
2	581 24 16-02	LEVER CONTROL CHUTE ROT
3	581 32 97-01	BOLT SHOULDER 1/4-20
4	581 32 96-01	SPRING COMPRESSION
5	586 66 89-01	NUT FL LOCK 1/4-20
6	584 46 84-02	BRACE SUPPORT SPEED
7	587 03 13-01	WASHER .625 X .375 X .094 NYLON 6/6

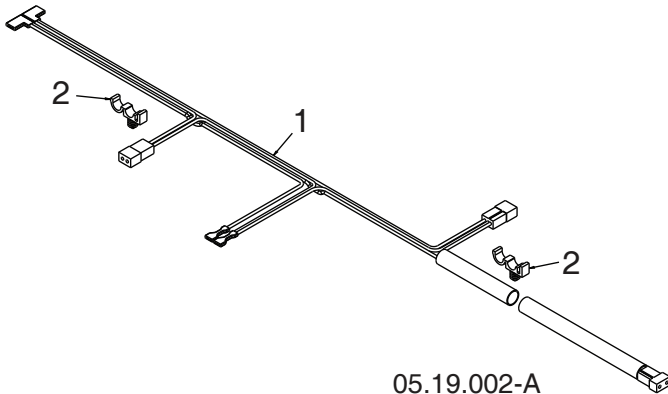

05.19.002-A

KEY NO.	PART NO.	DESCRIPTION
1	587 53 57-01	HARNES WIRE LIGHTS & GRIPS
2	532 14 50-06	WIRE RETAINER

NOTE: All component dimensions given in U.S. inches. 1 inch = 25.4 mm
IMPORTANT: Use only Original Equipment Manufacturer (O.E.M.) replacement parts. Failure to do so could be hazardous, damage your snow thrower and void your warranty.

REPAIR PARTS

CONTROL PANEL / DISCHARGE CHUTE

SNOW THROWER - MODEL NO. ST 224 (96191008704), PRODUCT NO. 961 91 00-87

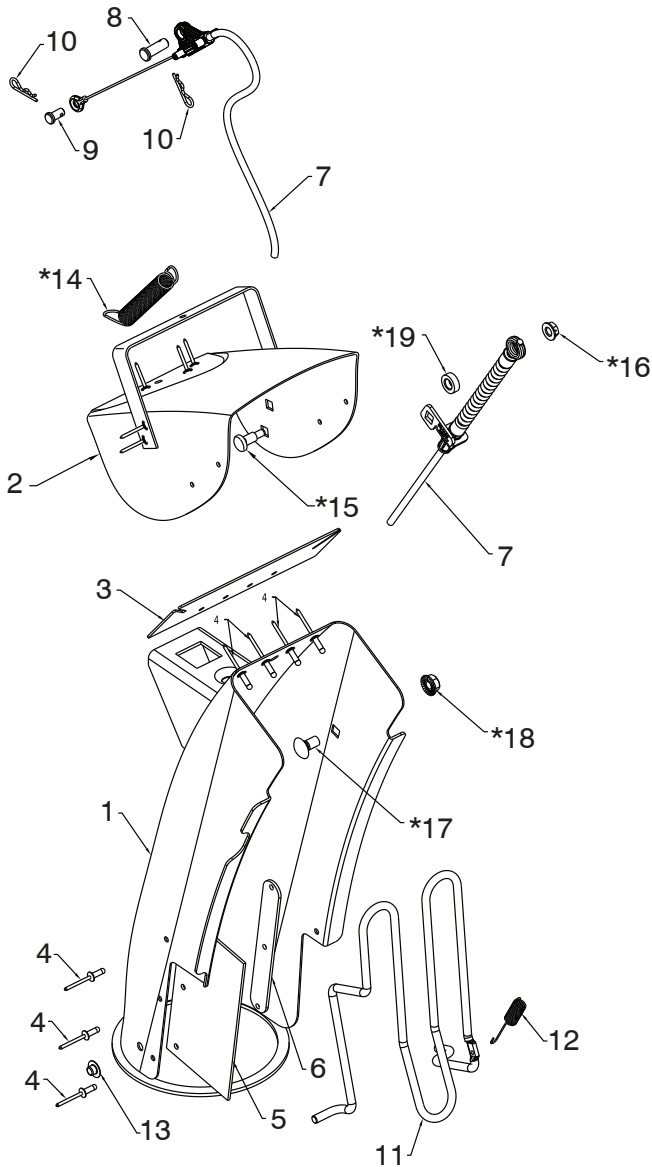

05.11.008-G

KEY NO.	PART NO.	DESCRIPTION
1	532 44 40-41	CHUTE WELDMENT (INCLUDES 1, 2, 3, 4, 5, 6)
2	-----	DEFLECTOR RIVET
3	-----	DEFLECTOR SEAL
4	-----	POP RIVET
5	-----	CHUTE SNOW SHIELD
6	-----	SHIELD STRAP RETAINER
7	590 58 70-01	CABLE ASM DEFLECTOR - BOWDEN
8	581 32 94-01	PIN CLEVIS 5/16 X .875
9	585 80 83-01	PIN CLEVIS 1/4 X .312
10	532 42 33-03	HAIRPIN RETAINER
11	532 43 55-82	CHUTE GUARD
12	532 43 56-16	GUARD RETURN SPRING
13	532 05 93-49	PUSH NUT
*14	532 18 45-05	DEFLECTOR SPRING
*15	501 41 73-01	CARRIAGE BOLT 1/4-20 X .544
*16	585 69 14-01	NUT 1/4-20
*17	585 83 20-01	CARRIAGE BOLT 3/8-16 X .625
*18	873 97 05-00	NUT 5/16-18
*19	501 41 74-01	WASHER .326 X .625 X .205 NYLON

NOTE: ALL ITEMS MARKED WITH AN * ARE PROVIDED IN THE BAG OF ITEMS SHIPPED LOOSE WITH PRODUCT.

NOTE: All component dimensions given in U.S. inches. 1 inch = 25.4 mm
IMPORTANT: Use only Original Equipment Manufacturer (O.E.M.) replacement parts. Failure to do so could be hazardous, damage your snow thrower and void your warranty.

REPAIR PARTS

CONTROL PANEL / DISCHARGE CHUTE

SNOW THROWER - MODEL NO. ST 224 (96191008704), PRODUCT NO. 961 91 00-87

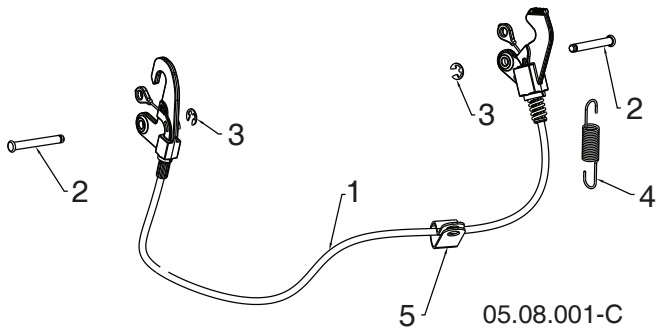

KEY NO.	PART NO.	DESCRIPTION
1	593 85 34-01	CABLE INTERLOCK
2	532 43 17-62	PIN GROOVED
3	812 00 00-14	E-RING
4	581 15 12-01	SPRING RETURN
5	532 19 79-91	CLIP CABLE BLACK

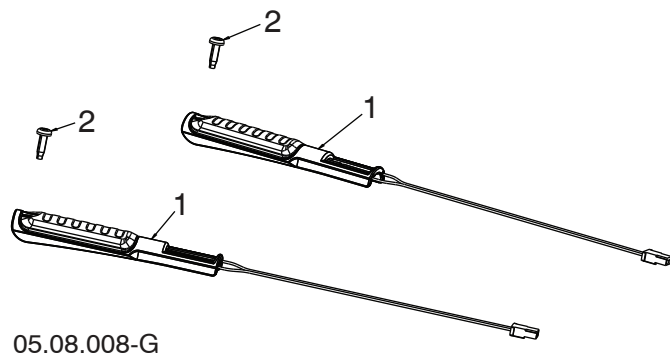

KEY NO.	PART NO.	DESCRIPTION
1	590 49 36-01	GRIP, HEATED, DSST SHO
2	532 44 22-50	SCREW PAN HD TORX 1/4-20 X .75

NOTE: All component dimensions given in U.S. inches. 1 inch = 25.4 mm
IMPORTANT: Use only Original Equipment Manufacturer (O.E.M.) replacement parts.
 Failure to do so could be hazardous, damage your snow thrower and void your warranty.

REPAIR PARTS

CONTROL PANEL / DISCHARGE CHUTE

SNOW THROWER - MODEL NO. ST 224 (96191008704), PRODUCT NO. 961 91 00-87

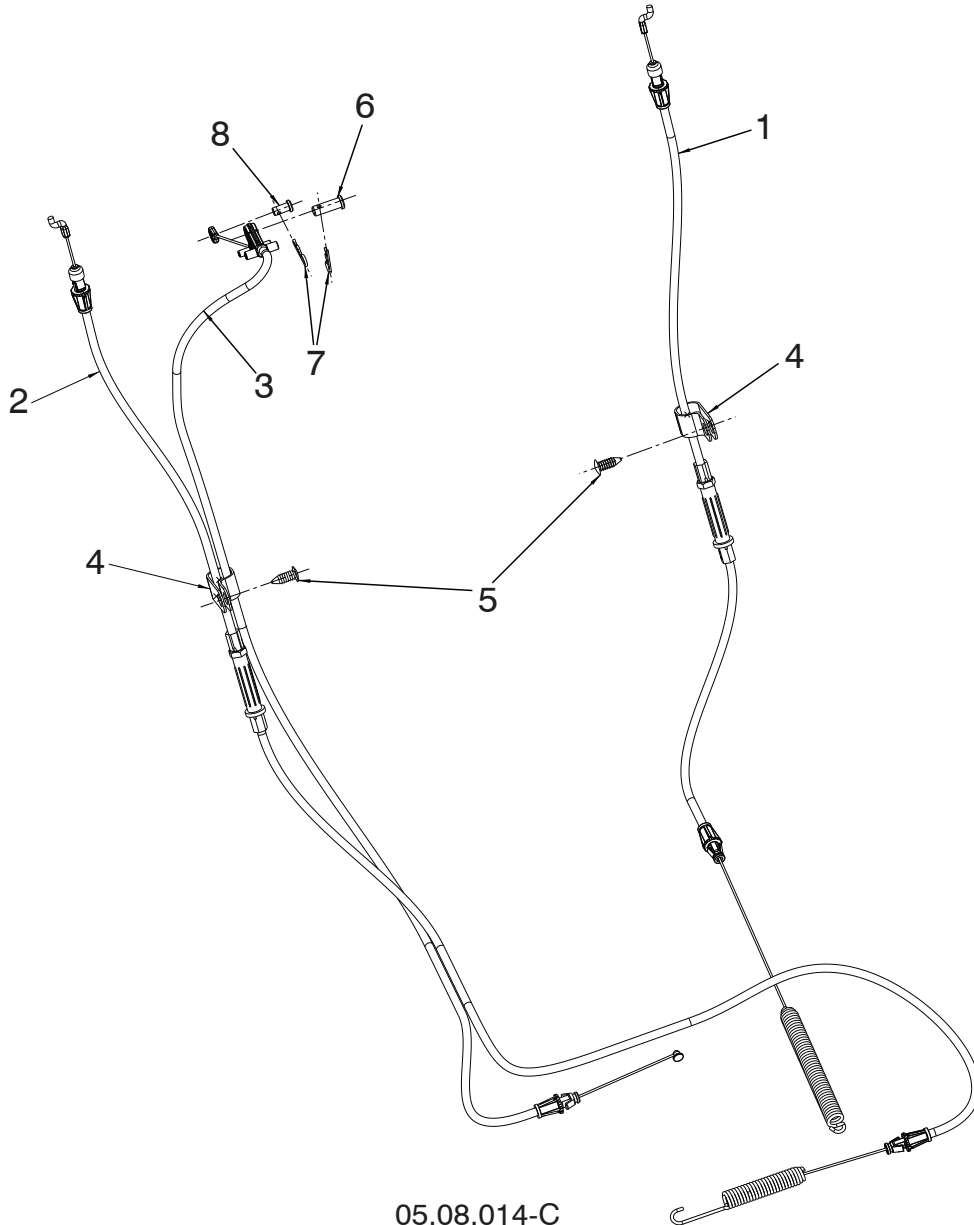

05.08.014-C

KEY NO.	PART NO.	DESCRIPTION
1	582 51 90-02	CABLE CONTROL DRIVE
2	588 11 38-02	CABLE CONTROL AUGER
3	588 12 23-01	CABLE CONTROL SPEED
4	532 19 79-91	CLIP CABLE
5	532 42 81-24	FASTENER PUSH .250
6	581 32 94-01	PIN CLEVIS 5/16
7	532 42 33-03	HAIRPIN
8	585 80 83-01	PIN CLEVIS 1/4

NOTE: All component dimensions given in U.S. inches. 1 inch = 25.4 mm
IMPORTANT: Use only Original Equipment Manufacturer (O.E.M.) replacement parts. Failure to do so could be hazardous, damage your snow thrower and void your warranty.

REPAIR PARTS

CONTROL PANEL / DISCHARGE CHUTE

SNOW THROWER - MODEL NO. ST 224 (96191008704), PRODUCT NO. 961 91 00-87

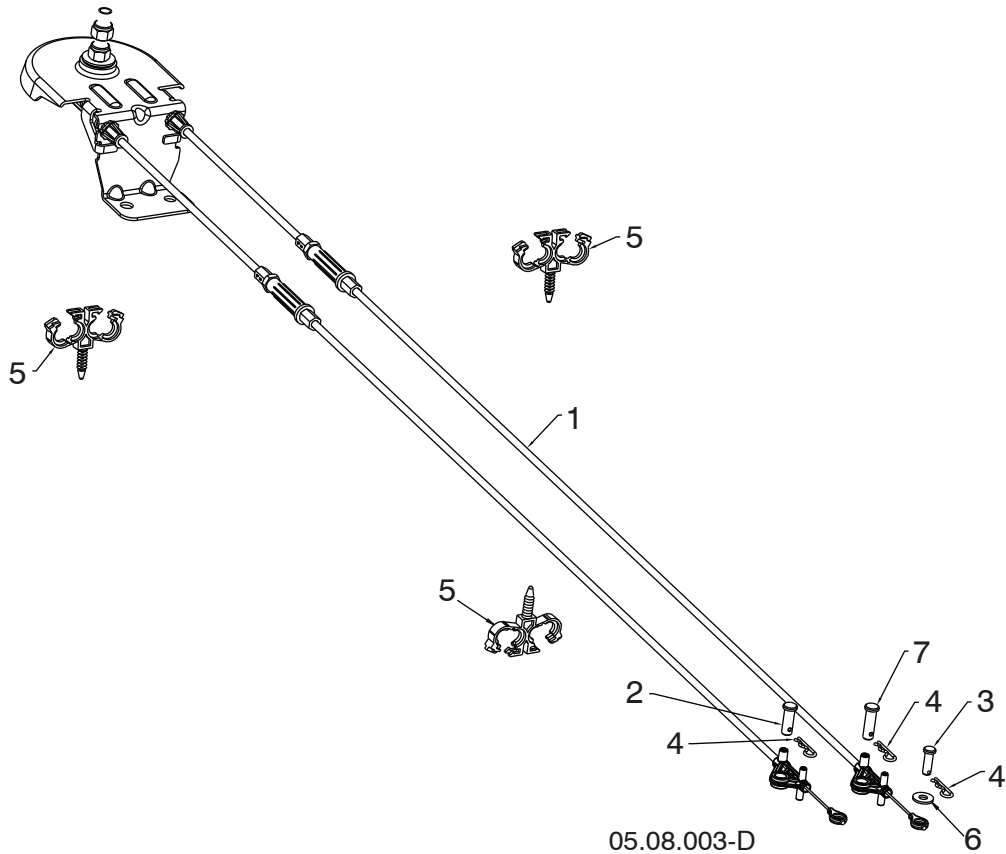

KEY NO.	PART NO.	DESCRIPTION
1	581 68 03-01	CABLE ROTATOR ASM
2	581 32 94-01	PIN CLEVIS 5/16 X 7/8
3	877 10 08-12	PIN CLEVIS 1/4 X 3/4
4	532 42 33-03	HAIRPIN SOFT ZINC
5	584 65 22-01	CLIP CONDUIT DOUBLE
6	586 68 21-01	WASHER
7	587 13 08-01	PIN CLEVIS 5/16 X 1

NOTE: All component dimensions given in U.S. inches. 1 inch = 25.4 mm
IMPORTANT: Use only Original Equipment Manufacturer (O.E.M.) replacement parts. Failure to do so could be hazardous, damage your snow thrower and void your warranty.

REPAIR PARTS

HANDLES

SNOW THROWER - MODEL NO. ST 224 (96191008704), PRODUCT NO. 961 91 00-87

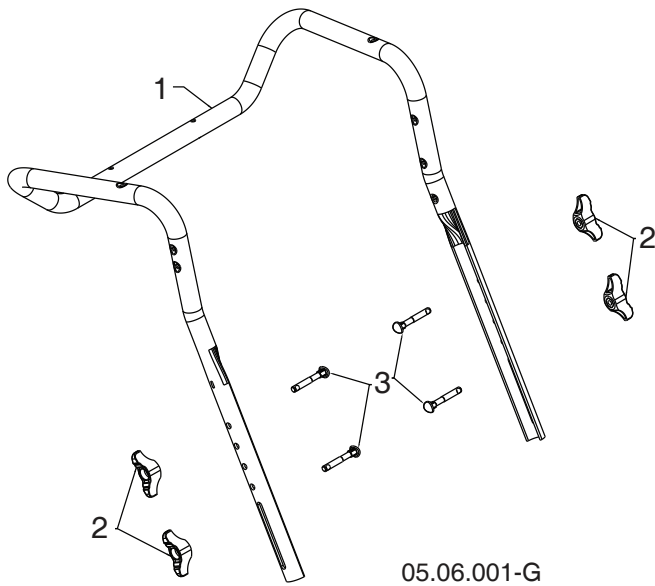

KEY NO.	PART NO.	DESCRIPTION
1	588 16 08-03	UPPER HANDLE
2	532 19 19-38	HANDLE KNOB STD BLACK
3	588 05 99-01	SCREW 5/16-18 X 2.25 CONCAVE HEAD WITH PATCH

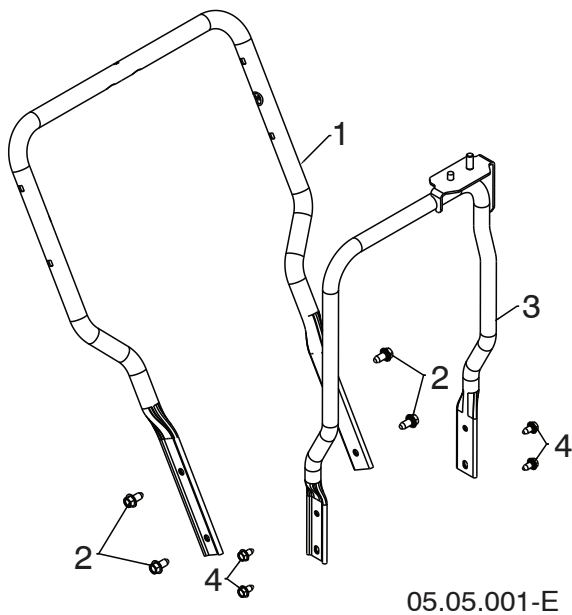

KEY NO.	PART NO.	DESCRIPTION
1	588 67 21-03	UPPER HANDLE
2	817 00 06-12	SCREW HEX WASH HD 3/8-16 X .75
3	589 26 45-04	CHUTE ROTATOR SUPPORT ASM
4	817 00 05-10	BOLT HEX 5/16-18

NOTE: All component dimensions given in U.S. inches. 1 inch = 25.4 mm
IMPORTANT: Use only Original Equipment Manufacturer (O.E.M.) replacement parts.
 Failure to do so could be hazardous, damage your snow thrower and void your warranty.

REPAIR PARTS

DRIVE

SNOW THROWER - MODEL NO. ST 224 (96191008704), PRODUCT NO. 961 91 00-87

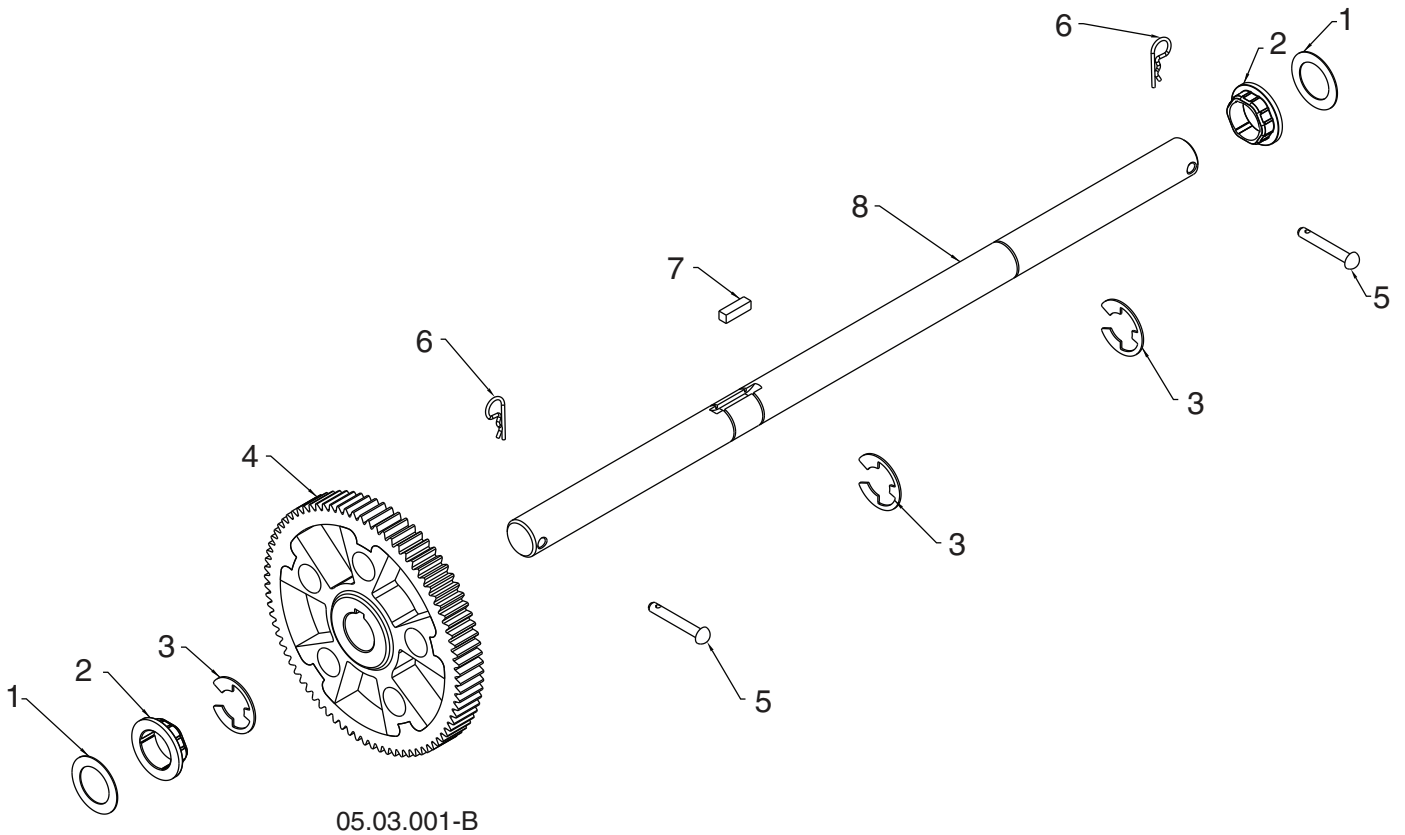

KEY NO.	PART NO.	DESCRIPTION
1	532 44 49-49	WASHER 1.00
2	587 97 89-01	HEX BUSHING 1 SHAFT
3	812 00 00-53	RETAINING RING
4	588 51 87-02	GEAR 80T DRIVEN
5	532 17 12-71	RIVET RD HD DRILLED 1/4 DIA
6	532 12 47-88	RETAINER SPRING
7	532 18 92-82	SQUARE KEY 1/4 X .875
8	581 12 20-01	AXLE SHAFT

NOTE: All component dimensions given in U.S. inches. 1 inch = 25.4 mm
IMPORTANT: Use only Original Equipment Manufacturer (O.E.M.) replacement parts.
 Failure to do so could be hazardous, damage your snow thrower and void your warranty.

REPAIR PARTS

DRIVE

SNOW THROWER - MODEL NO. ST 224 (96191008704), PRODUCT NO. 961 91 00-87

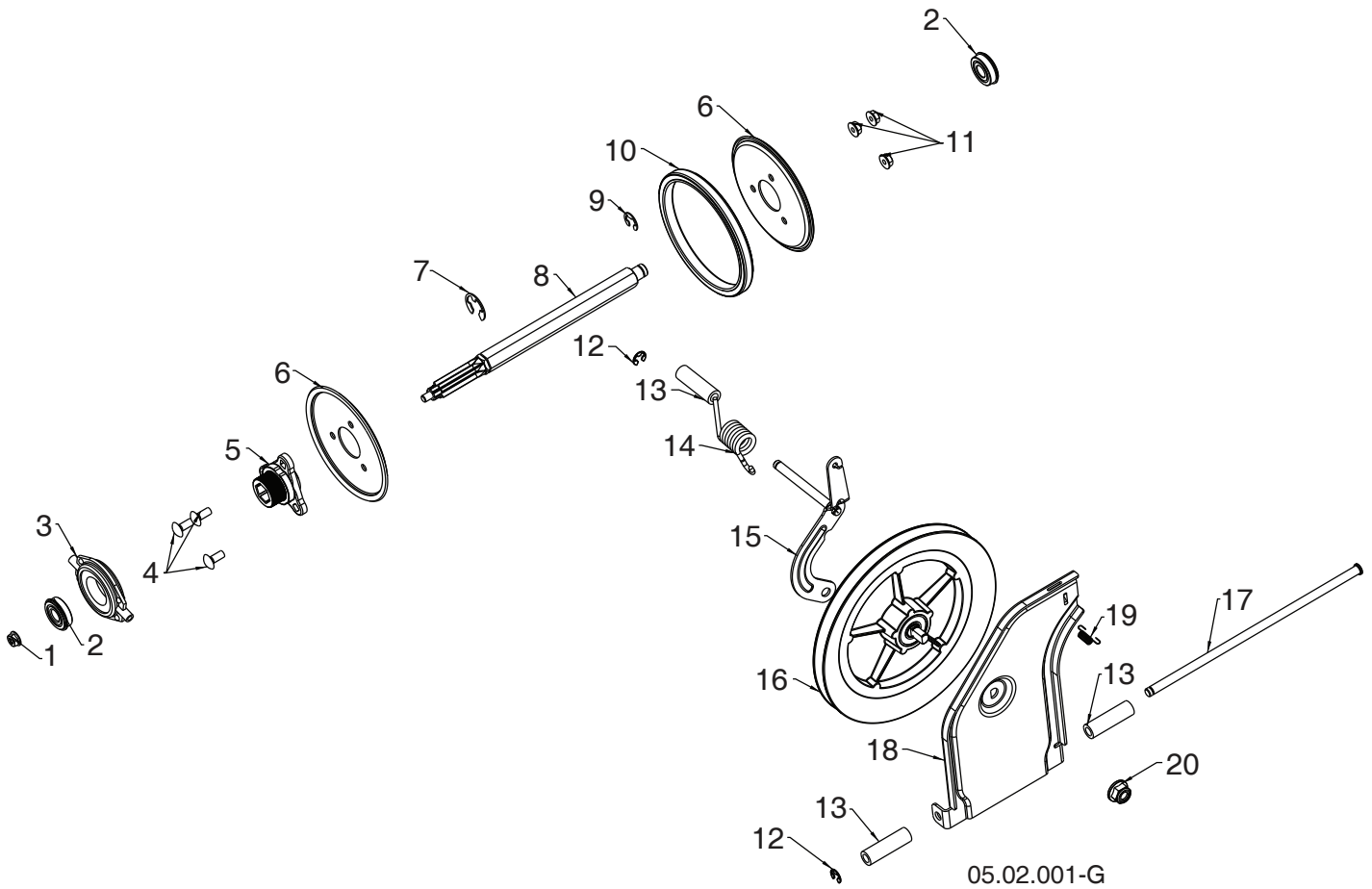

NOTE: All component dimensions given in U.S. inches. 1 inch = 25.4 mm
IMPORTANT: Use only Original Equipment Manufacturer (O.E.M.) replacement parts.
Failure to do so could be hazardous, damage your snow thrower and void your warranty.

SNOW THROWER - MODEL NO. **ST 224** (96191008704), PRODUCT NO. 961 91 00-87

KEY NO.	PART NO.	DESCRIPTION
1	585 69 15-01	NUT HEX FLANGE LK 5/16-18
2	580 75 62-01	BEARING 9/16 I.D. 1622-2RSNR
3	532 17 53-44	TRUNNION BEARING ASM
4	872 11 05-06	BOLT CARRIAGE 5/16-18 X .75 GR 5
5	581 09 09-01	HUB RUBBER WHEEL
6	581 09 10-02	RUBBER WHEEL PLATE
7	812 00 00-22	E-RING
8	581 12 19-01	SHAFT 7 TOOTH REDUCTION
9	580 75 61-02	RETAINING RING 1622-2RSNR
10	581 09 11-01	RUBBER WHEEL RING
11	532 75 11-53	NUT HEX FLANGE LK 5/16-18
12	812 00 00-07	E-RING RETAINER 375
13	581 73 27-01	DRIVE SPACER
14	581 31 53-01	DRIVE TORSION SPRING
15	587 19 34-03	YOKE BRACKET ASSEMBLY
16	581 32 84-01	FRICTION PULLEY DISC COMBO
17	581 12 30-01	ROD TIP PLATE
18	587 70 34-02	FRICTION SWING PLATE PULL
19	532 19 38-85	LATCH SPRING
20	521 99 11-01	NUT HEX FLANGE LK 1/2-13

NOTE: All component dimensions given in U.S. inches. 1 inch = 25.4 mm
IMPORTANT: Use only Original Equipment Manufacturer (O.E.M.) replacement parts.
 Failure to do so could be hazardous, damage your snow thrower and void your warranty.

REPAIR PARTS

CHASSIS / ENGINE / PULLEYS

SNOW THROWER - MODEL NO. ST 224 (96191008704), PRODUCT NO. 961 91 00-87

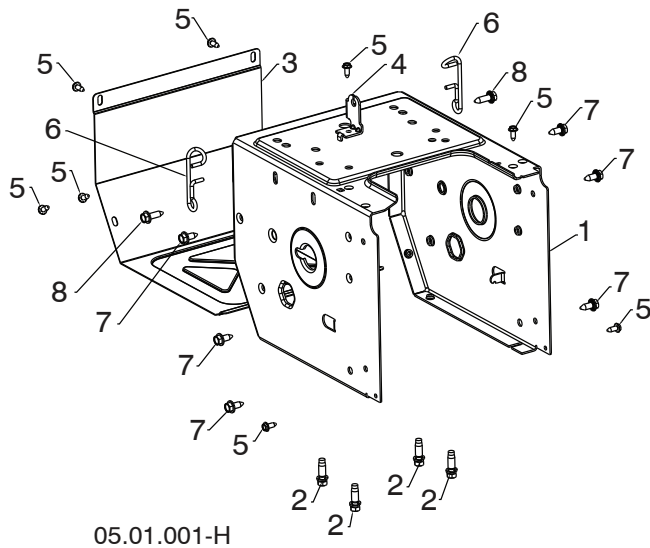

05.01.001-H

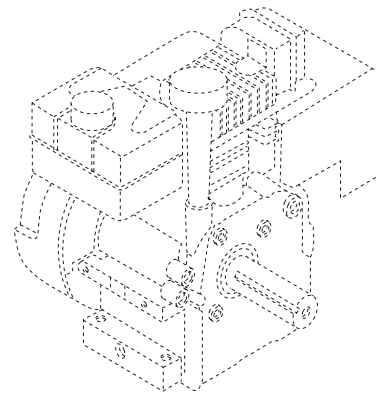

KEY NO.	PART NO.	DESCRIPTION
--	590 21 86-04	COMPLETE LCT ENGINE PW2HK18650178Y
1	589 26 47-05	FRAME
2	532 15 04-06	ENGINE BOLT 3/8-16 X 1.280 DOGPOINT
3	580 83 95-05	FRAME COVER
4	501 06 04-03	SHIFTER BRACKET
5	582 90 69-01	SCREW HEX WASHER 1/4-20 X .625
6	588 95 45-01	WIREFORM SUPPORT CABLE
7	532 42 88-67	BOLT HEXHD WASHER 5/16-18 X .750
8	585 21 75-01	BOLT HEXHD WASHER 5/16-18 X 1.000

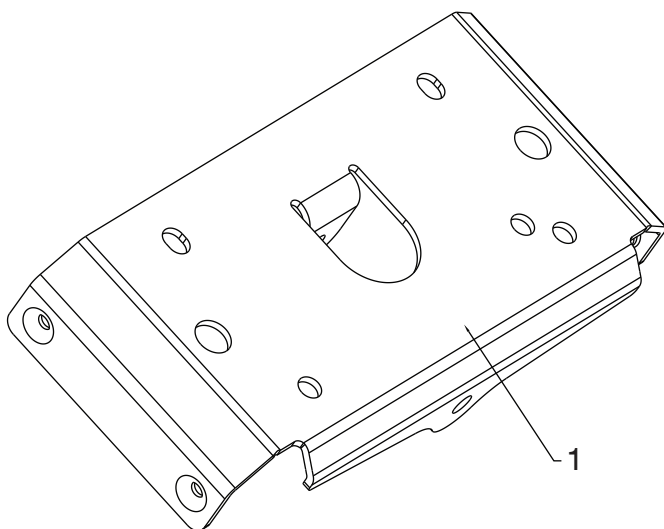

05.01.002-A

KEY NO.	PART NO.	DESCRIPTION
1	583 94 05-02	SMALL MOUNTING PLATE

NOTE: All component dimensions given in U.S. inches. 1 inch = 25.4 mm
IMPORTANT: Use only Original Equipment Manufacturer (O.E.M.) replacement parts. Failure to do so could be hazardous, damage your snow thrower and void your warranty.

REPAIR PARTS

CHASSIS / ENGINE / PULLEYS

SNOW THROWER - MODEL NO. ST 224 (96191008704), PRODUCT NO. 961 91 00-87

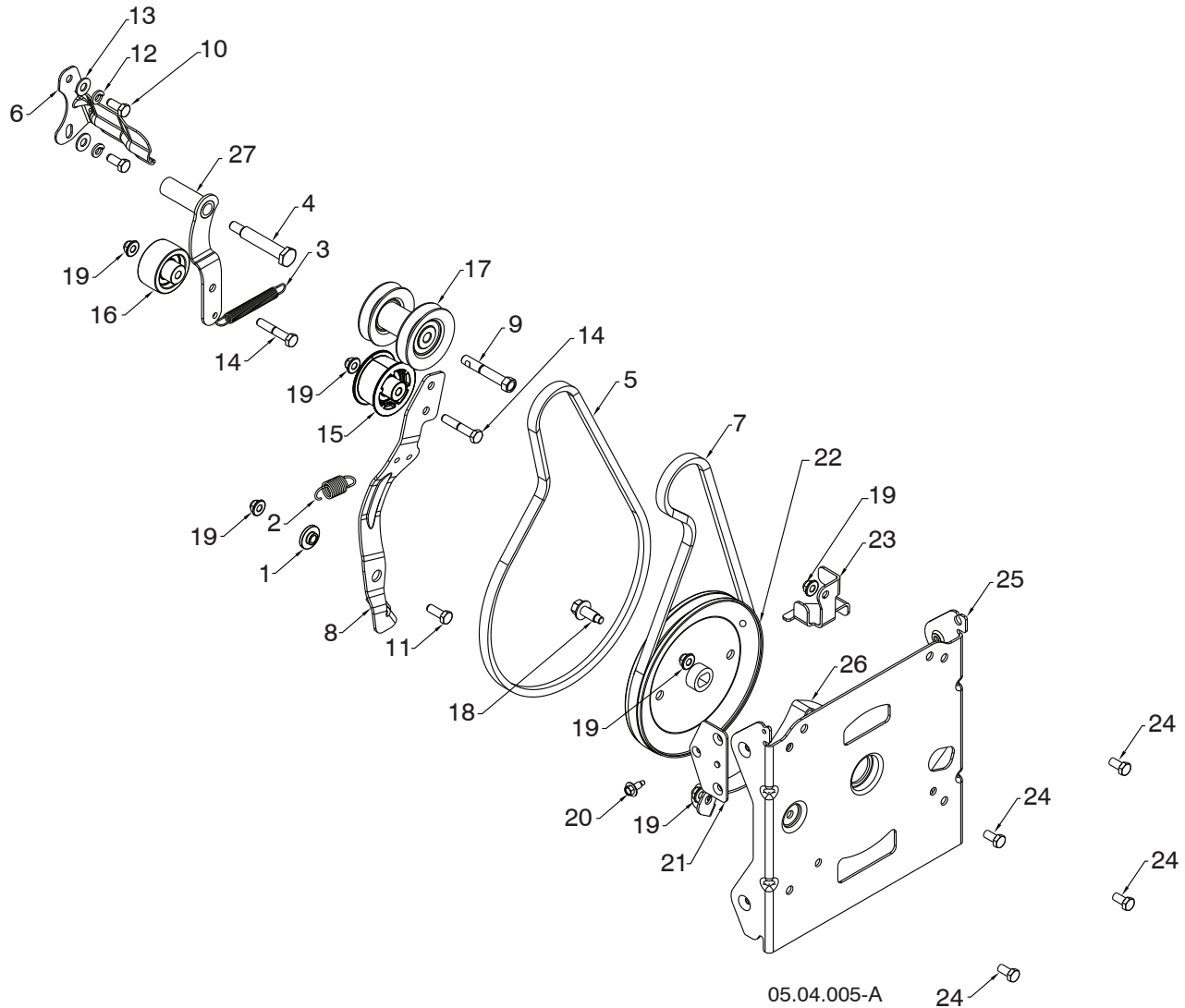

KEY NO.	PART NO.	DESCRIPTION	KEY NO.	PART NO.	DESCRIPTION
1	587 34 37-01	BUSHING BRAKE ARM	16	586 88 02-01	PULLEY IDLER 2.0 O/ SPACER
2	587 03 12-01	SPRING RETURN IDLER ARM	17	587 89 37-03	PULLEY ASM IMPELLER / DRIVE
3	580 75 30-01	SPRING RETURN IDLER ARM	18	583 81 49-01	SCREW FLANGE HEAD 3/8-16
4	581 41 38-01	BOLT SHOULDER 5/16-24 X 2.15	19	532 42 79-42	NUT NYLOK FLANGE 5/16-18
5	584 21 61-02	BELT DRIVE 4L X 38.19	20	585 51 78-01	SCREW 1/4-20 X .65 W/DOG POINT
6	588 49 28-02	BRACKET BELT KEEPER 007	21	590 04 46-02	BRACKET NUT BZP
7	501 81 82-01	BELT IMPELLER LOW CRANK	22	590 69 92-01	PULLEY IMPELLER DD 4L
8	580 83 11-06	ARM IDLER AUTO PH .676	23	587 58 72-02	GUIDE LOWER AUGER BELT 479
9	582 38 84-01	BOLT ENGINE PULLEY	24	532 16 31-83	BOLT HXHD 5/16-18 X 5/8
10	874 61 05-12	CAPSCREW HEXHD 5/16-24 X .75 GR5	25	581 59 25-02	BRACKET AUG HOUSING INTER 479
11	874 76 05-14	BOLT HEXHD 5/16-18 X .875	26	581 63 20-02	BRACKET BELT KEEPER LOWER 479
12	810 04 05-00	LOCKWASHER 5/16 SPLIT HVY	27	581 33 82-03	ARM IDLER DRIVE
13	819 11 1216	WASHER 11/32 X 3/4 X 16GA			
14	874 76 05-28	BOLT HXHD 5/16-18 X 1.75			
15	581 14 14-01	PULLEY IDLER 2.0 WITH SPACER			

NOTE: All component dimensions given in U.S. inches. 1 inch = 25.4 mm
IMPORTANT: Use only Original Equipment Manufacturer (O.E.M.) replacement parts. Failure to do so could be hazardous, damage your snow thrower and void your warranty.

REPAIR PARTS

CHASSIS / ENGINE / PULLEYS

SNOW THROWER - MODEL NO. ST 224 (96191008704), PRODUCT NO. 961 91 00-87

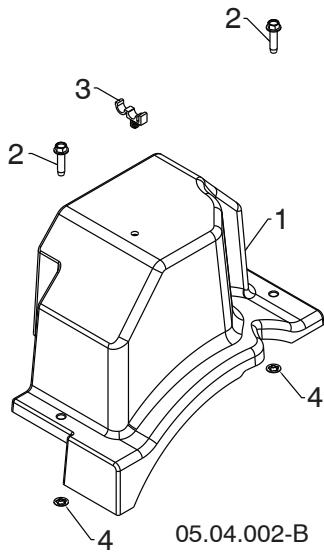

KEY NO.	PART NO.	DESCRIPTION
1	587 10 54-01	BELT COVER BLACK ASSEMBLY (INCLUDES 2 & 4)
2	-----	BOLT HEX WSH THDRL 1/4-20 X 1
3	532 14 50-06	CABLE GUIDE
4	-----	PALNUT 1/4 IN

NOTE: All component dimensions given in U.S. inches. 1 inch = 25.4 mm
IMPORTANT: Use only Original Equipment Manufacturer (O.E.M.) replacement parts. Failure to do so could be hazardous, damage your snow thrower and void your warranty.

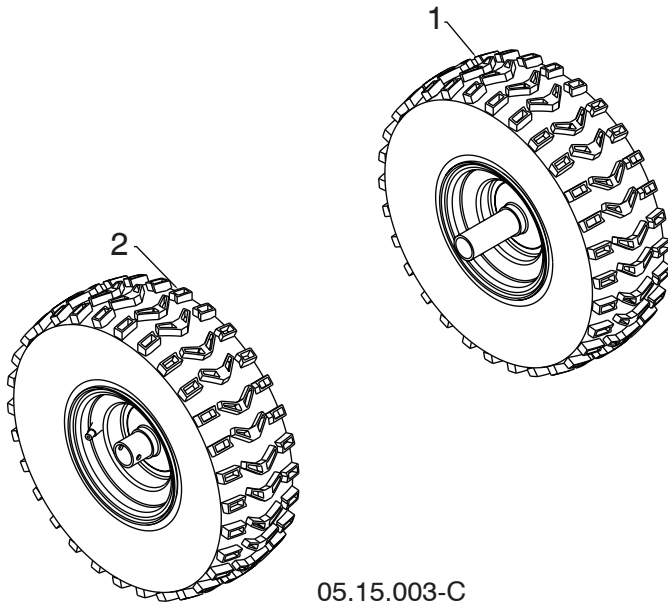

KEY NO.	PART NO.	DESCRIPTION
1	586 71 04-01	WHEEL 15X5.00 NPS LH 1.00 K478
2	586 71 03-01	WHEEL 15X5.00 NPS RH 1.00 K478

NOTE: All component dimensions given in U.S. inches. 1 inch = 25.4 mm
IMPORTANT: Use only Original Equipment Manufacturer (O.E.M.) replacement parts.
 Failure to do so could be hazardous, damage your snow thrower and void your warranty.

REPAIR PARTS

BAG OF PARTS

SNOW THROWER - MODEL NO. **ST 224** (96191008704), PRODUCT NO. 961 91 00-87

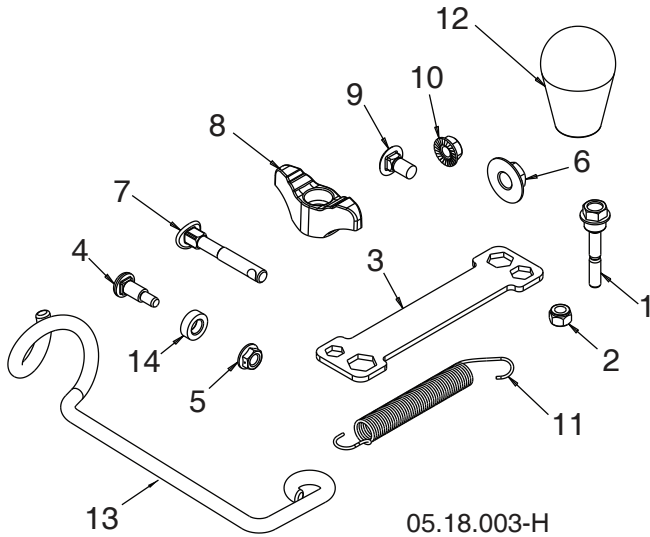

KEY NO.	PART NO.	DESCRIPTION
1	588 07 75-01	BOLT 1/4-20 X 1.81
2	873 80 04-00	NUT NYLOCK 1/4-20
3	532 42 91-12	WRENCH
4	501 41 73-01	BOLT SHOULDER
5	585 69 14-01	NUT HEX FL 1/4-20 CTR
6	585 69 10-01	NUT NYLOCK 3/8-16
7	588 05 99-01	BOLT 5/16-18 X 2.25 CONCAVE
8	532 19 19-38	KNOB 5/16-18 TWO-WING
9	585 83 20-01	BOLT 5/16-18 X .625
10	873 97 05-00	NUT SERR FL LOCK 5/16-18
11	532 18 45-05	SPRING DEFLECT CHUTE
12	581 69 75-01	KNOB SOFT TOUCH SLOTTED
13	581 89 73-01	SUPPORT ROTATION CABLE
14	501 41 74-01	WASHER NYLON
NI	588 07 76-03	KIT REPLACEMENT BAG OF PARTS

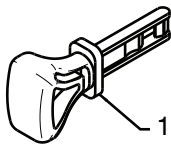

01.14.009-B

KEY NO.	PART NO.	DESCRIPTION
1	532 44 30-59	SAFETY IGNITION KEY KIT

NOTE: All component dimensions given in U.S. inches. 1 inch = 25.4 mm
IMPORTANT: Use only Original Equipment Manufacturer (O.E.M.) replacement parts.
 Failure to do so could be hazardous, damage your snow thrower and void your warranty.

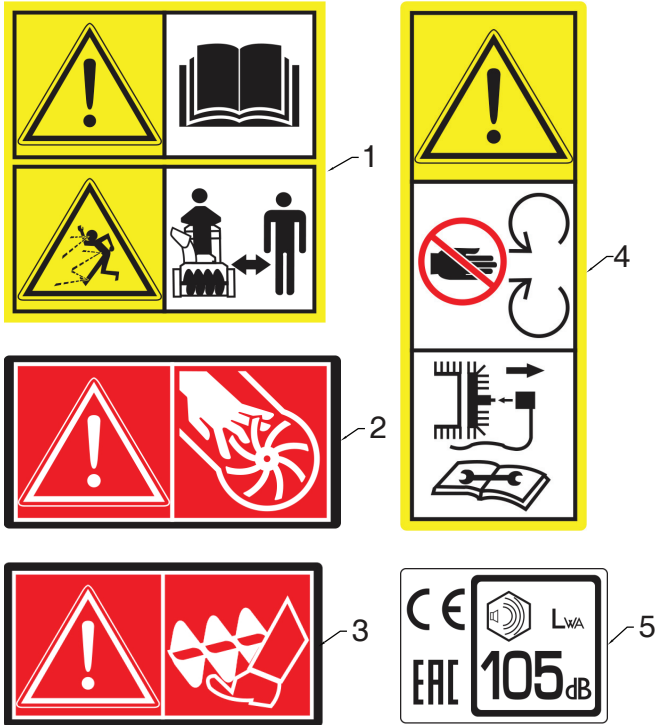

KEY NO.	PART NO.	DESCRIPTION
1	532 18 40-45	DECAL AUGER
2	590 81 22-01	DECAL CHUTE
3	532 19 96-83	DECAL AUGER SAFETY
4	532 18 40-28	DECAL BELT GUIDE
5	589 59 27-01	DECAL NOISE LEVEL

05.16.002-B

NOTE: All component dimensions given in U.S. inches. 1 inch = 25.4 mm
IMPORTANT: Use only Original Equipment Manufacturer (O.E.M.) replacement parts.
 Failure to do so could be hazardous, damage your snow thrower and void your warranty.

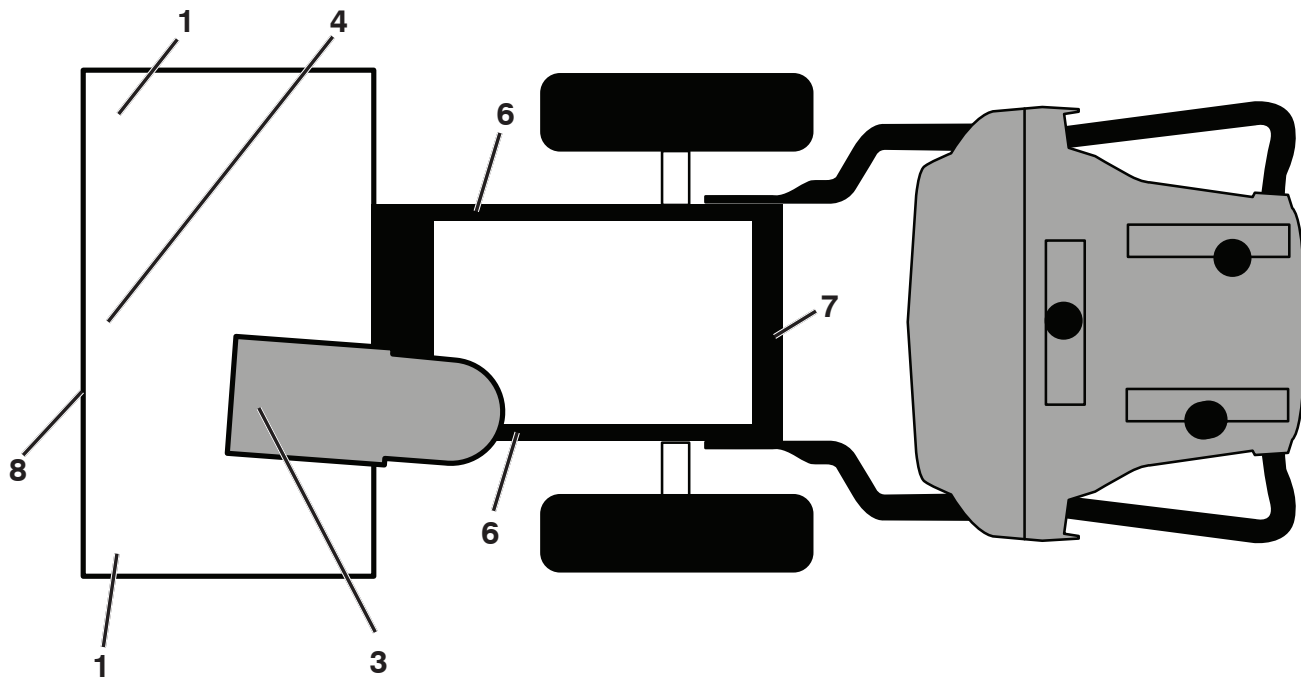

KEY PART NO.	PART NO.	DESCRIPTION
1	532 19 96-83	DECAL, DANGER
3	590 81 22-01	DECAL, DANGER, DEFLECTOR
4	532 18 40-45	DECAL, DANGER
6	532 18 40-28	DECAL, BELT GUARD
7	589 59 27-01	DECAL, NOISE LEVEL
8	588 59 71-01	DECAL, AUGER HOUSING
--	590 69 72-01	DECAL, ENGINE RECOIL (NOT SHOWN)
--	115 99 57-20	OPERATOR'S MANUAL, EURO
--	115 99 57-10	OPERATOR'S MANUAL, SCAN
--	115 99 57-50	OPERATOR'S MANUAL, EBLOC
--	115 99 57-40	OPERATOR'S MANUAL, BALTIC
--	115 99 57-53	OPERATOR'S MANUAL, UKR
--	115 99 57-76	OPERATOR'S MANUAL TURK

NOTE: All component dimensions given in U.S. inches. 1 inch = 25.4 mm
IMPORTANT: Use only Original Equipment Manufacturer (O.E.M.) replacement parts. Failure to do so could be hazardous, damage your snow thrower and void your warranty.

ENGINE, LCT

COMPLETE ENGINE-590218604

GEN II 136/179/208/254cc Snow Engines

9999 Options

DECALS ← 72

Carburetor Repair Kit ← 70

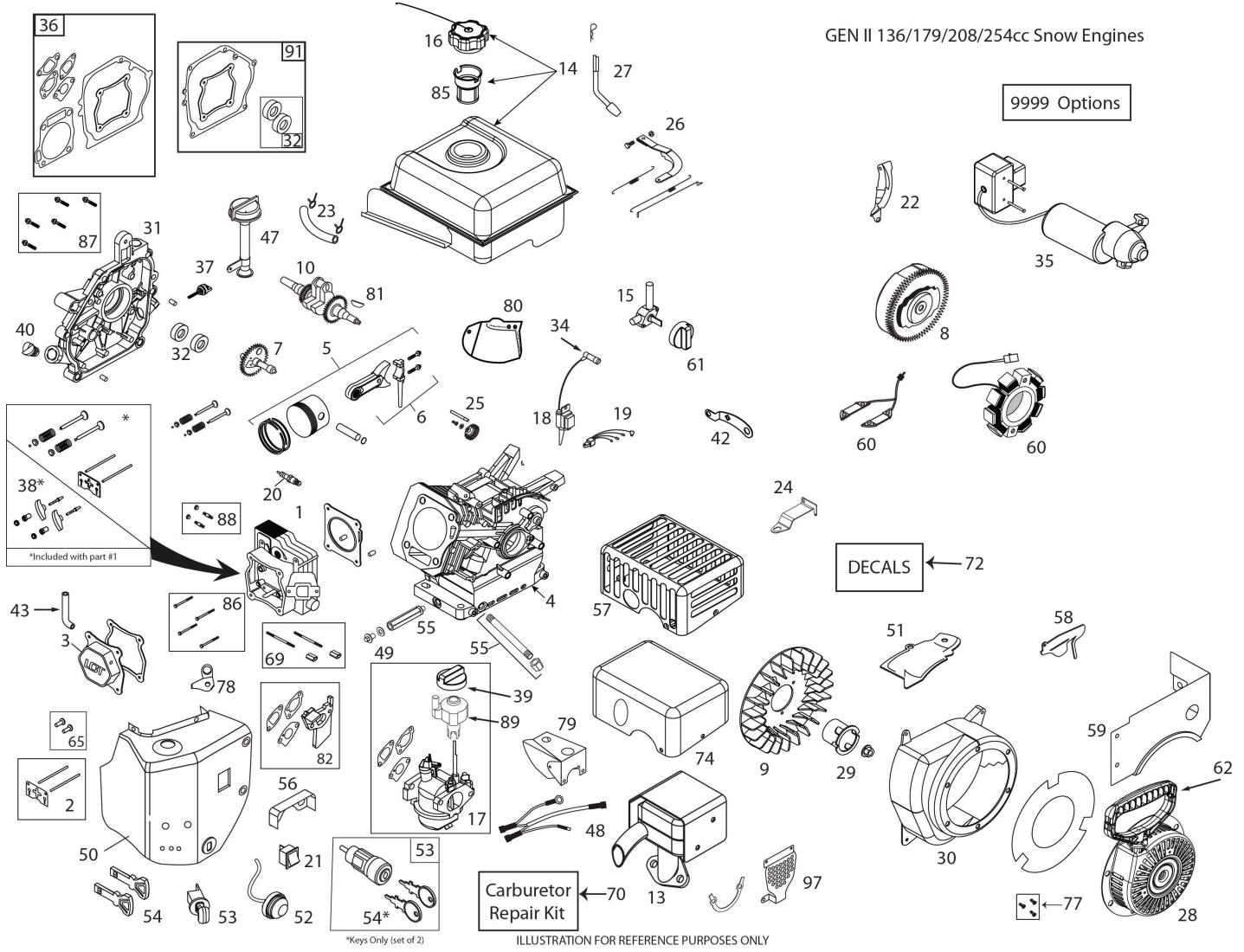

KEY PART NO. NO.

DESCRIPTION

1	532 42 05-78	CYLINDER HEAD ASSEMBLY (INCL. GASKET)
2	532 42 05-79	PUSH ROD & PLATE KIT (INCL. VALVE COVER GSKT)
3	532 42 05-80	VALVE COVER (INCL. GASKET)
5	532 42 05-82	PISTON & ROD ASSEMBLY
7	532 42 05-84	CAMSHAFT
8	595 01 24-01	FLYWHEEL - ELECTRIC START W/ 6 MAGNETS
9	532 42 05-86	COOLING FAN - FLYWHEEL
10	532 44 66-42	CRANKSHAFT
13	587 73 78-01	MUFFLER ASSEMBLY
14	532 43 65-64	FUEL TANK (2.7L BLACK W/PLASTIC CAP)
15	532 42 92-34	FUEL TANK ON/OFF VALVE
16	532 42 49-42	FUEL TANK CAP - BLACK CLICK STYLE (VENTED)

KEY PART NO. NO.

DESCRIPTION

17	587 14 79-01	CARBURETOR (W/IDLE SPEED CONTROL - W/GSKTS)
18	532 44 39-34	IGNITION COIL
20	532 42 49-39	SPARK PLUG
22	585 77 24-01	SHIELD - FLYWHEEL
23	532 43 21-44	FUEL HOSE KIT
24	532 42 92-59	SPEED CONTROL BRACKET (FIXED)
25	532 42 96-46	GOVERNOR GEAR ASSEMBLY
26	581 76 87-01	GOVERNOR ARM & LINK KIT
27	532 42 06-02	GOVERNOR ARM PADDLE
28	532 43 69-67	RECOIL STARTER ASSY
29	532 43 69-68	STARTER CUP
30	581 19 20-01	BLOWER HOUSING
31	581 00 73-01	CRANKCASE COVER ASSY (PRESS-IN TYPE HOFT)(INCL. GASKET)

*Keys Only (set of 2)

ILLUSTRATION FOR REFERENCE PURPOSES ONLY

ENGINE, LCT**COMPLETE ENGINE-590218604**

KEY PART NO.	PART NO.	DESCRIPTION	KEY PART NO.	PART NO.	DESCRIPTION
32	532 42 95-99	OIL SEAL KIT (2 PCS)	60	532 44 38-93	60 WATT AC CHARGING COIL
34	532 43 69-66	SPARK PLUG BOOT	61	532 43 27-52	FUEL CONTROL KNOB
35	595 91 55-01	230V ELECTRIC STARTER	65	581 37 28-01	TAPPET KIT (SET OF 2)
36	532 42 96-01	ENGINE GASKET KIT	69	532 42 49-51	CARBURETOR STUDS & COUPLING KIT
37	532 42 09-61	SMALL BLACK OIL DIPSTICK (PLASTIC)	70	580 35 36-02	CARBURETOR REPAIR KIT
38	532 42 96-91	ROCKER ARM KIT (INCL. GAS-KET)	72	587 15 22-01	LABEL KIT
39	532 42 92-24	CHOKE CONTROL KNOB	74	587 82 11-01	MUFFLER HEAT SHIELD COVER
40	532 42 95-98	NON-REMOVABLE PLASTIC PLUG	77	532 43 26-88	RECOIL BOLT KIT (3 BOLTS PER KIT)
43	580 35 34-01	BREATHER TUBE	78	581 45 93-01	BREATHER TUBE BRACKET
47	581 00 72-01	HIGH OIL-FILL TUBE/DIPSTICK (PRESS-IN TYPE)	79	SEE REF 58	PART OF REF 58, ALL ONE PART
48	595 01 25-01	WIRE HARNESS (W/O ON/OFF SWITCH)	80	SEE REF 58	PART OF REF 58, ALL ONE PART
49	532 43 54-95	OIL DRAIN PLUG W/WASHER	81	585 29 72-01	WOODRUFF FLYWHEEL KEYS (5-PACK) (5X6X18MM)(208/414CC)
50	595 01 26-01	HEATER BOX (W/O ON/OFF SWITCH)	82	585 02 05-03	CARBURETOR SPACER KIT
51	532 43 71-19	SHIELD - CYLINDER	85	586 32 56-01	FUEL TANK STRAINER
52	532 42 49-49	PRIMER BULB WITH HOSE	86	586 32 73-02	CYLINDER HEAD BOLT KIT (4)
53	532 42 49-54	SAFETY KEY SWITCH (INCL. KEYS)	87	586 32 69-01	CC COVER BOLT KIT (6)
54	532 44 30-59	KEY SET - RED (2)	88	586 32 68-01	MUFFLER MTG STUD KIT (2)
55	532 43 26-86	OIL DRAIN TUBE-SNOW	89	587 12 48-01	SPEED CONTROL KNOB
56	SEE REF 59	PART OF REF 58, ALL ONE PIECE	91	587 52 57-01	CRANKCASE GASKET KIT
58	595 01 27-01	GOV AND CARB SHIELD - COMPOSITE (ALSO REPLS 56,79,80)	97	589 75 26-01	MUFFLER MANIFOLD SHIELD
59	532 43 65-62	FUEL TANK SKIRT	9999	586 32 62-01	HIGH ALTITUDE JET (>6,000 FEET)
			9999	579 80 64-01	BOLT KIT - BLOWER HSG-HEATER BOX-TANK SKIRT
			9999	590 92 08-01	STARTER SWITCH BOX SCREWS

