

ILLUSTRATED PARTS LIST

MODEL NUMBER ST 3261

PRODUCT NUMBER 961 92 01-02

MFG. ID. NUMBER 96192010200

REPAIR PARTS

AUGER HOUSING / IMPELLER ASSEMBLY

SNOW THROWER - MODEL NO. ST 3261 (96192010200), PRODUCT NO. 961 92 01-02

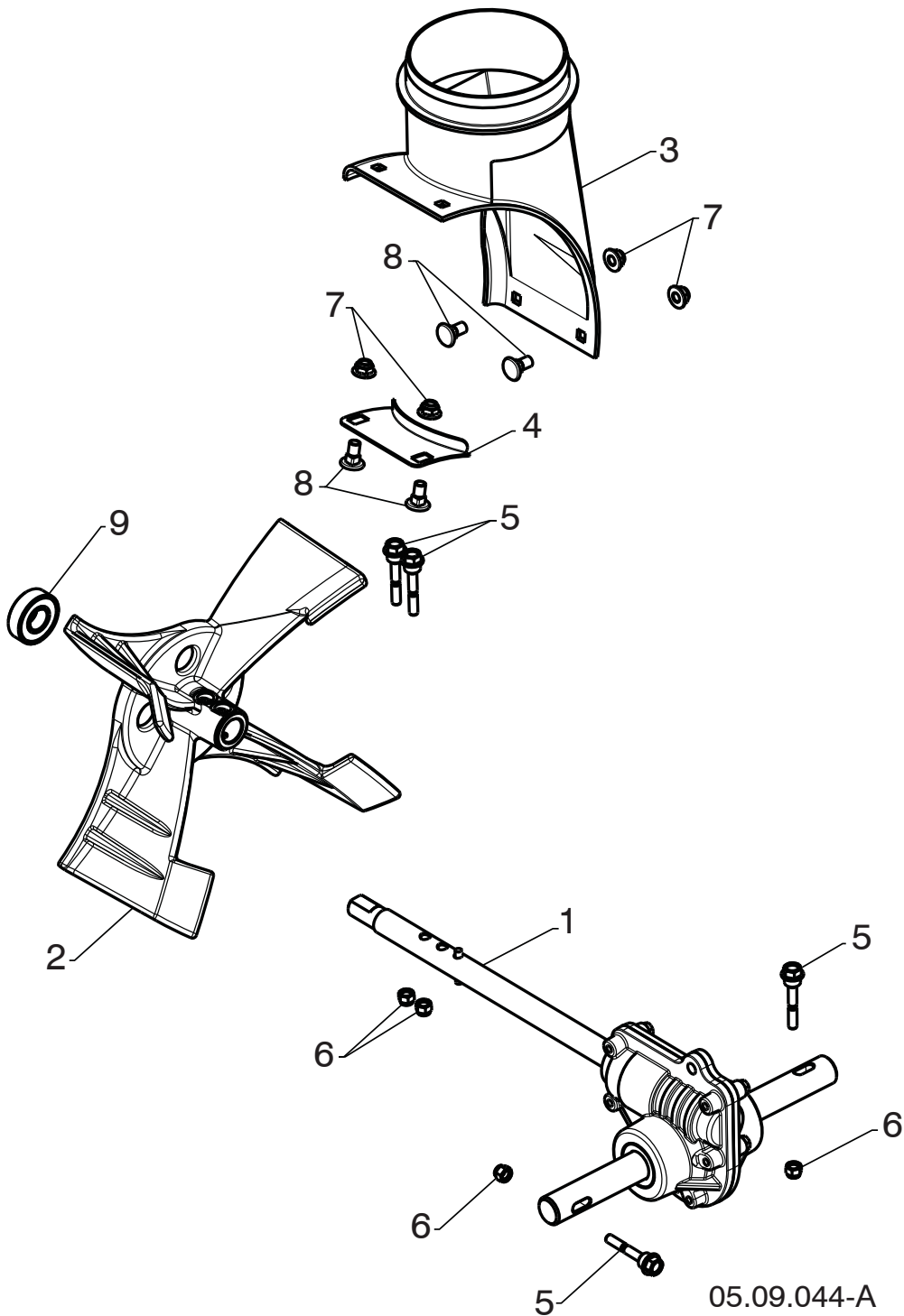

NOTE: All component dimensions given in U.S. inches. 1 inch = 25.4 mm
IMPORTANT: Use only Original Equipment Manufacturer (O.E.M.) replacement parts. Failure to do so could be hazardous, damage your snow thrower and void your warranty.

REPAIR PARTS**AUGER HOUSING / IMPELLER ASSEMBLY****SNOW THROWER - MODEL NO. ST 3261 (96192010200), PRODUCT NO. 961 92 01-02**

KEY NO.	PART NO.	DESCRIPTION
1	582 86 77-01	AUGER TRANSMISSION CAST IRON
2	585 19 83-03	IMPELLER
3	585 05 69-01	CHUTE DISCHARGE BASE
4	532 17 86-75	BRACKET CORNER DISCHARGE BASE
5	588 07 75-01	BOLT SHEAR 1/4-20
6	873 80 04-00	NUT NYLOCK 1/4-20
7	585 69 13-01	NUT FLANGE NYLOCK 5/16-18
8	585 69 12-01	BOLT CARRIAGE WAFER HEAD 5/16-18 X 5/8
9	532 19 87-91	BEARING BALL

NOTE: All component dimensions given in U.S. inches. 1 inch = 25.4 mm
IMPORTANT: Use only Original Equipment Manufacturer (O.E.M.) replacement parts.
Failure to do so could be hazardous, damage your snow thrower and void your warranty.

REPAIR PARTS

AUGER HOUSING / IMPELLER ASSEMBLY

SNOW THROWER - MODEL NO. ST 3261 (96192010200), PRODUCT NO. 961 92 01-02

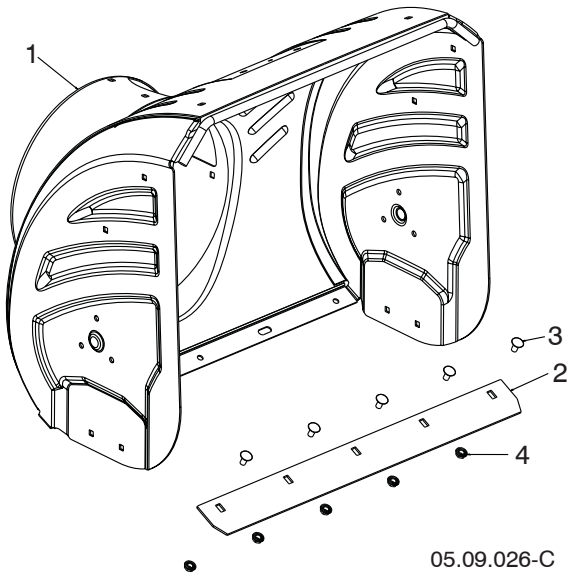

05.09.026-C

KEY NO.	PART NO.	DESCRIPTION
1	585 91 61-06	AUGER HOUSING 24 LS
2	585 04 83-02	SHAVE PLATE 24 LS MS428
3	872 27 05-05	BOLT CARRIAGE 5/16-18 X .625
4	532 15 53-77	NUT 5-16-18 HEX TOP LOCK

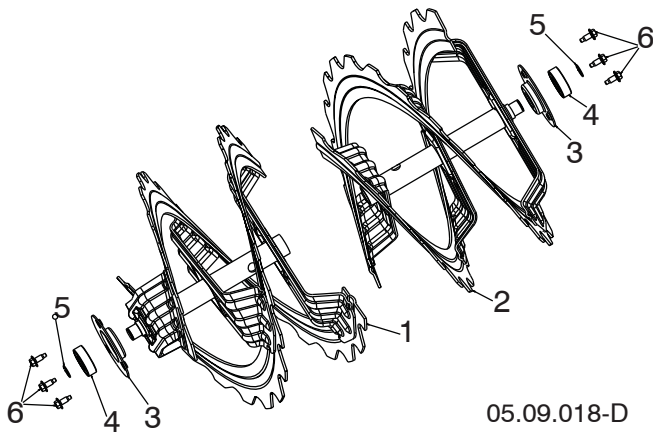

05.09.018-D

KEY NO.	PART NO.	DESCRIPTION
1	581 97 01-06	AUGER RIBBON 24 RH LS
2	581 97 02-06	AUGER RIBBON 24 LH LS
3	532 43 40-10	SUPPORT AUGER BEARING
4	800 11 04-85	BEARING IDLER 6203
5	812 00 00-28	RING RETAINING #5100-52
6	585 51 78-01	SCREW 1/4-20 X .65 W/DOG POINT

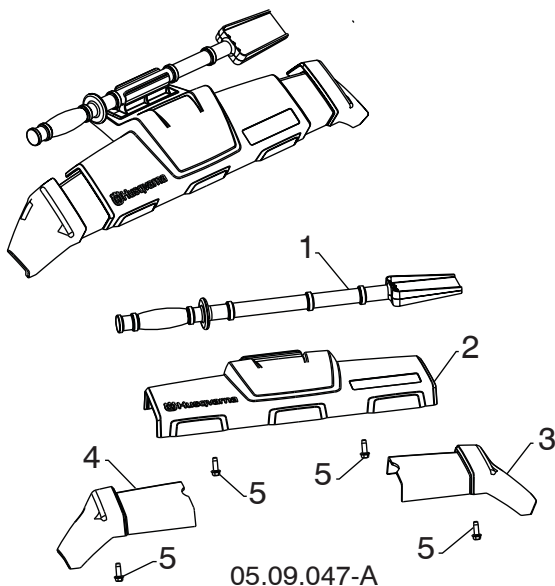

05.09.047-A

KEY NO.	PART NO.	DESCRIPTION
1	532 19 21-99	TOOL CLEANOUT
2	586 41 48-02	AUGER FRONT TRIM ASM
3	586 33 03-02	TRIM AUGER HOUSING WING RH
4	586 33 04-02	TRIM AUGER HOUSING WING LH
5	817 06 04-10	SCREW HEX WASHER 1/4-20 X 5/8

NOTE: All component dimensions given in U.S. inches. 1 inch = 25.4 mm
IMPORTANT: Use only Original Equipment Manufacturer (O.E.M.) replacement parts. Failure to do so could be hazardous, damage your snow thrower and void your warranty.

REPAIR PARTS

AUGER HOUSING / IMPELLER ASSEMBLY

SNOW THROWER - MODEL NO. ST 3261 (96192010200), PRODUCT NO. 961 92 01-02

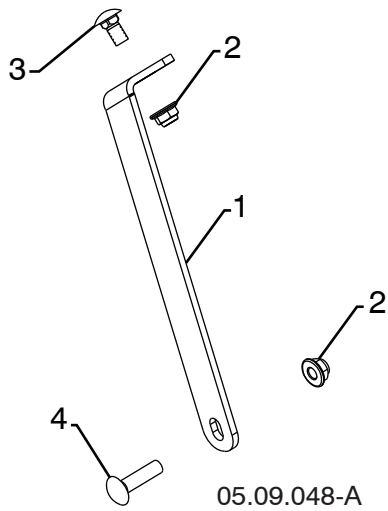

KEY NO.	PART NO.	DESCRIPTION
1	585 10 90-02	SUPPORT GEARBOX LS
2	585 69 13-01	NUT HEX FLG NYLOCK BLK 5/16-18
3	585 83 20-01	BOLT CARRIAGE BLK 5/16-18 X 5/8 BLK
4	872 11 05-10	BOLT CARRIAGE 5/16-18 X 1-1/4

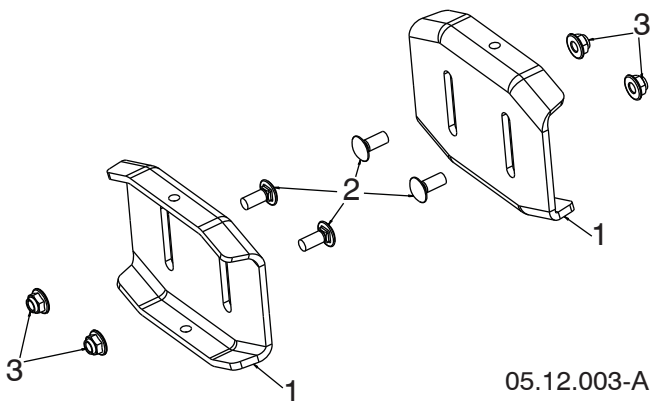

KEY NO.	PART NO.	DESCRIPTION
1	532 40 49-75	SKID PLATE
2	585 69 17-01	BOLT CARRIAGE 5/16-18 X .750 – BLK
3	585 69 13-01	NUT FLANGE NYLOCK 5/16-18 – BLK

NOTE: All component dimensions given in U.S. inches. 1 inch = 25.4 mm
IMPORTANT: Use only Original Equipment Manufacturer (O.E.M.) replacement parts.
 Failure to do so could be hazardous, damage your snow thrower and void your warranty.

REPAIR PARTS

CONTROL PANEL / DISCHARGE CHUTE

SNOW THROWER - MODEL NO. ST 3261 (96192010200), PRODUCT NO. 961 92 01-02

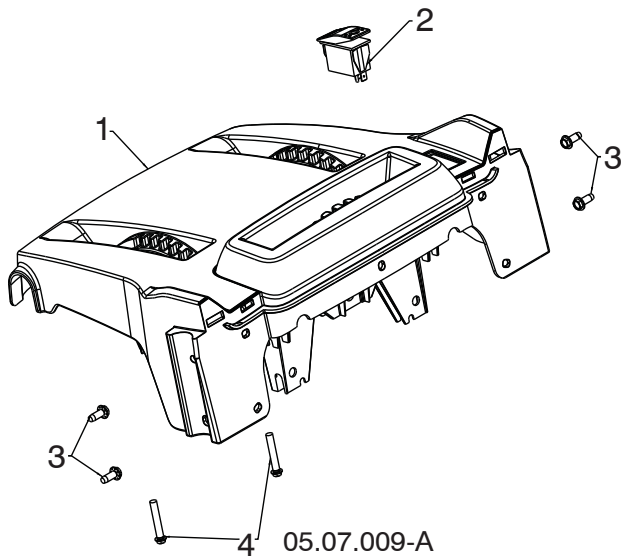

KEY NO.	PART NO.	DESCRIPTION
1	581 13 12-03	CONSOLE BASE MULTICONT W/SWITCH
2	585 80 50-01	SWITCH GRIP HEATED BLACK
3	817 06 04-10	SCREW TA SEMI GIMLE 1/4-20 X .62
4	581 32 95-01	SCREW HEX WASHER 13-16 X 1.50

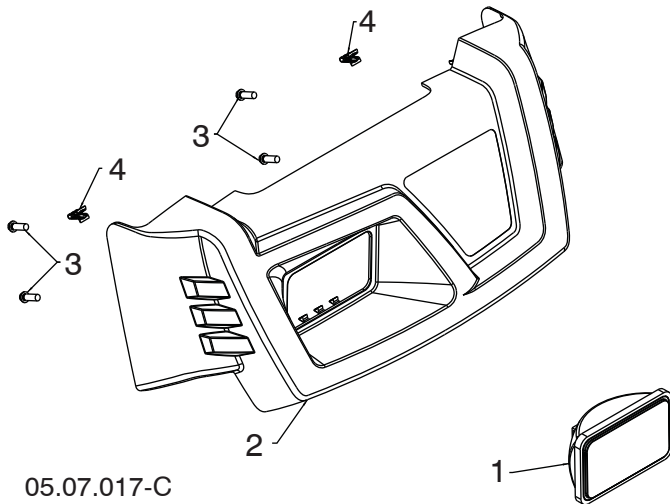

KEY NO.	PART NO.	DESCRIPTION
1	586 18 10-01	FLOOD HEADLIGHT
2	581 12 81-07	CONSOLE COVER JONSERED
3	532 19 41-89	SCREW HI-LO 13-16 X 5/8
4	581 92 87-01	PANEL CLIP
--	532 18 37-84	BULB (NOT SHOWN)

NOTE: All component dimensions given in U.S. inches. 1 inch = 25.4 mm
IMPORTANT: Use only Original Equipment Manufacturer (O.E.M.) replacement parts. Failure to do so could be hazardous, damage your snow thrower and void your warranty.

REPAIR PARTS

CONTROL PANEL / DISCHARGE CHUTE

SNOW THROWER - MODEL NO. ST 3261 (96192010200), PRODUCT NO. 961 92 01-02

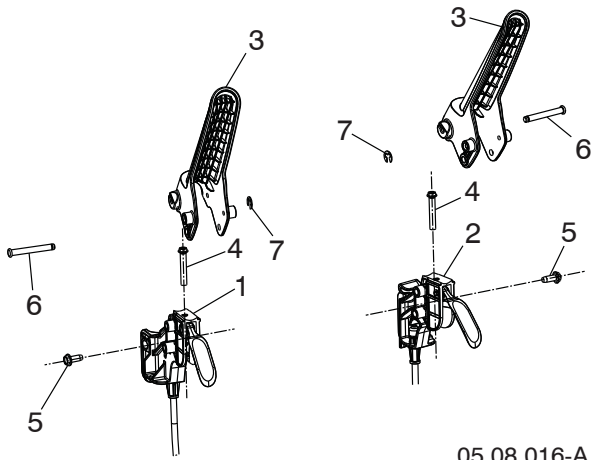

KEY NO.	PART NO.	DESCRIPTION
1	588 26 39-01	CABLE, POWER STEER - LHS
2	588 26 39-02	CABLE, POWER STEER - RHS
3	582 91 78-01	LEVER, CONTROL
4	581 32 95-01	SCREW HI-LOW 13-16 X 1.50
5	817 06 04-10	SCREW 1/4-20 X .625
6	532 43 17-62	PIN, GROOVED
7	812 00 00-14	E-RING

05.08.016-A

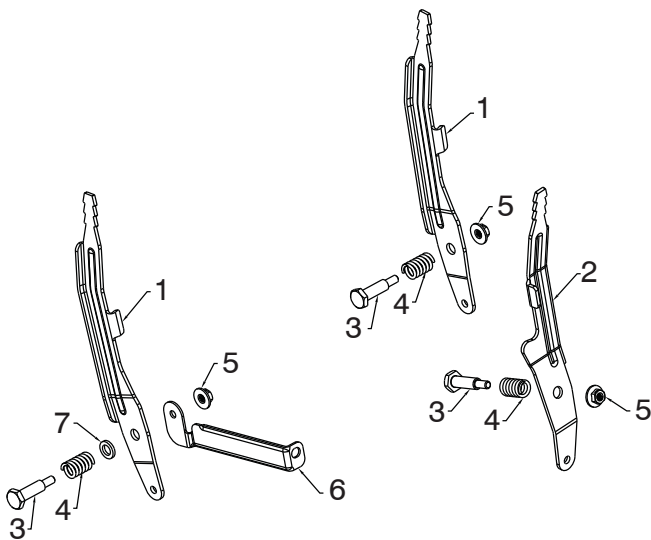

KEY NO.	PART NO.	DESCRIPTION
1	581 12 39-02	LEVER CONTROL SPEED/DEFL
2	581 24 16-02	LEVER CONTROL CHUTE ROT
3	581 32 97-01	BOLT SHOULDER 1/4-20
4	581 32 96-01	SPRING COMPRESSION
5	586 66 89-01	NUT FL LOCK 1/4-20
6	584 46 84-02	BRACE SUPPORT SPEED
7	587 03 13-01	WASHER .625 X .375 X .094 NYLON 6/6

05.08.005-C

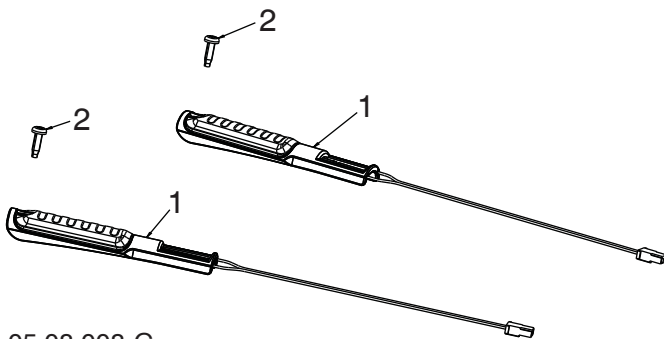

KEY NO.	PART NO.	DESCRIPTION
1	590 49 36-01	GRIP, HEATED, DSST SHO
2	532 44 22-50	SCREW PAN HD TORX 1/4-20 X .75

05.08.008-G

NOTE: All component dimensions given in U.S. inches. 1 inch = 25.4 mm
IMPORTANT: Use only Original Equipment Manufacturer (O.E.M.) replacement parts. Failure to do so could be hazardous, damage your snow thrower and void your warranty.

REPAIR PARTS

CONTROL PANEL / DISCHARGE CHUTE

SNOW THROWER - MODEL NO. ST 3261 (96192010200), PRODUCT NO. 961 92 01-02

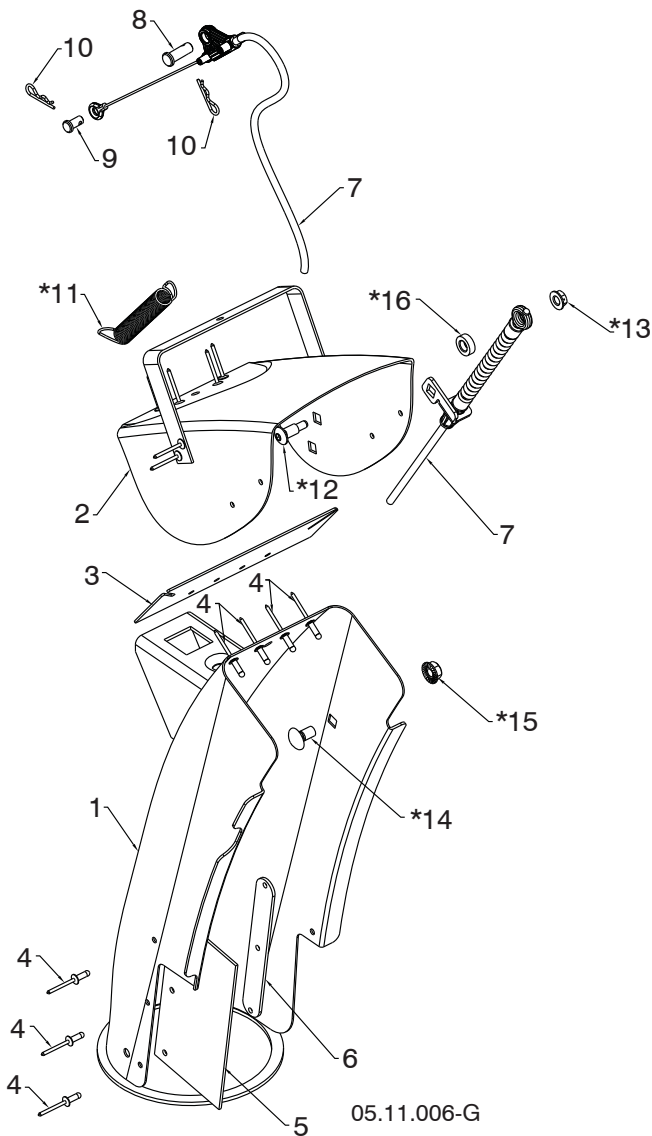

KEY NO.	PART NO.	DESCRIPTION
1	588 07 78-04	CHUTE WELDMENT ASSEMBLY (INCLUDES 1-6)
2	-----	RIVETED DEFLECTOR ASSEMBLY
3	-----	DEFLECTOR SEAL
4	-----	POP RIVET
5	-----	CHUTE SNOW SHIELD
6	-----	SHIELD STRAP RETAINER
7	590 58 70-01	CONTROL CHUTE DEFLECTOR BOWDEN
8	581 32 94-01	PIN CLEVIS 5/16 X .875
9	585 80 83-01	PIN CLEVIS 1/4 X .312
10	532 42 33-03	HAIRPIN RETAINER
*11	532 18 45-05	DEFLECTOR SPRING
*12	501 41 73-01	CARRIAGE BOLT 1/4-20 X .544
*13	585 69 14-01	NUT 1/4-20
*14	585 83 20-01	CARRIAGE BOLT 3/8-16 X .625
*15	873 97 05-00	NUT 5/16-18
*16	501 41 74-01	WASHER .362 X .625 X .205 NYLON

NOTE: ALL ITEMS MARKED WITH AN * ARE PROVIDED IN THE BAG OF ITEMS SHIPPED LOOSE WITH PRODUCT.

NOTE: All component dimensions given in U.S. inches. 1 inch = 25.4 mm
IMPORTANT: Use only Original Equipment Manufacturer (O.E.M.) replacement parts. Failure to do so could be hazardous, damage your snow thrower and void your warranty.

REPAIR PARTS

CONTROL PANEL / DISCHARGE CHUTE

SNOW THROWER - MODEL NO. ST 3261 (96192010200), PRODUCT NO. 961 92 01-02

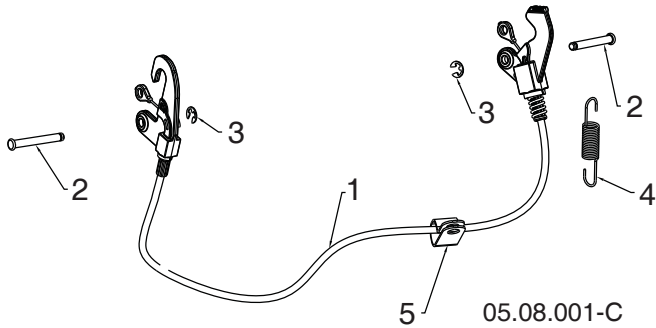

KEY NO.	PART NO.	DESCRIPTION
1	593 85 34-01	CABLE INTERLOCK
2	532 43 17-62	PIN GROOVED
3	812 00 00-14	E-RING
4	581 15 12-01	SPRING RETURN
5	532 19 79-91	CLIP CABLE BLACK

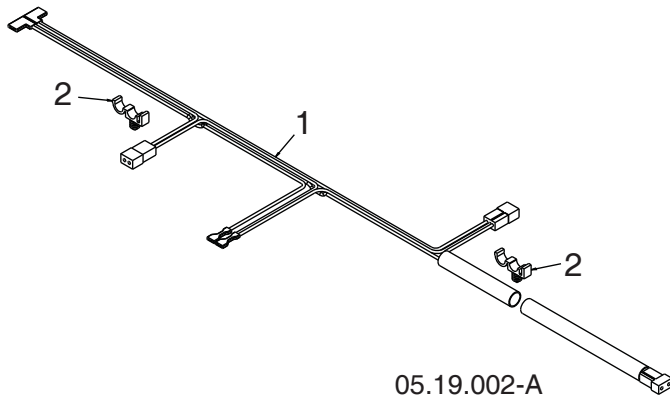

KEY NO.	PART NO.	DESCRIPTION
1	587 53 57-01	HARNESS WIRE LIGHTS & GRIPS
2	532 14 50-06	WIRE RETAINER

NOTE: All component dimensions given in U.S. inches. 1 inch = 25.4 mm
IMPORTANT: Use only Original Equipment Manufacturer (O.E.M.) replacement parts. Failure to do so could be hazardous, damage your snow thrower and void your warranty.

REPAIR PARTS

CONTROL PANEL / DISCHARGE CHUTE

SNOW THROWER - MODEL NO. ST 3261 (96192010200), PRODUCT NO. 961 92 01-02

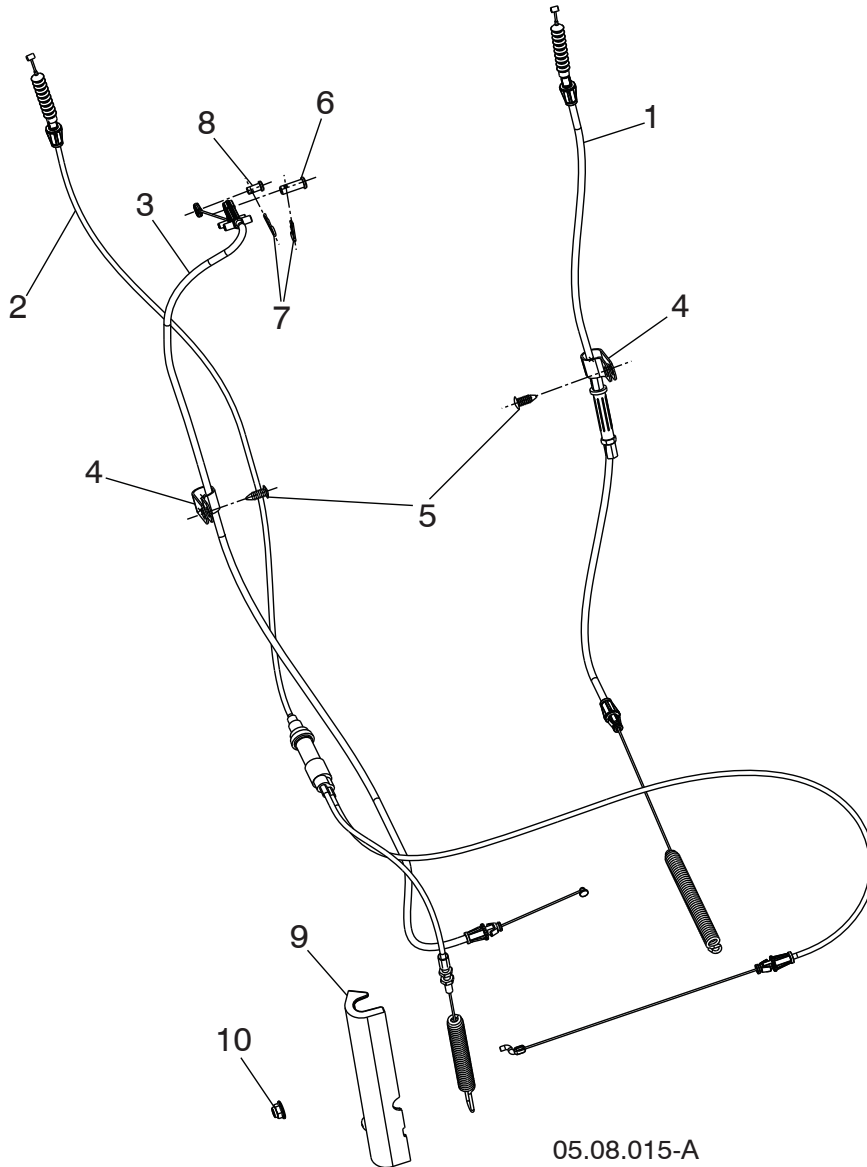

KEY NO.	PART NO.	DESCRIPTION
1	501 65 66-02	CABLE CONTROL DRIVE
2	579 76 36-01	CABLE CONTROL AUGER
3	588 12 23-01	CABLE CONTROL SPEED
4	532 19 79-91	CLIP CABLE
5	532 42 81-24	FASTENER PUSH .250
6	581 32 94-01	PIN CLEVIS 5/16
7	532 42 33-03	HAIRPIN
8	585 80 83-01	PIN CLEVIS 1/4
9	589 26 52-01	CABLE COVER
10	532 42 79-42	5/16-18 HEX NUT

NOTE: All component dimensions given in U.S. inches. 1 inch = 25.4 mm
IMPORTANT: Use only Original Equipment Manufacturer (O.E.M.) replacement parts. Failure to do so could be hazardous, damage your snow thrower and void your warranty.

REPAIR PARTS

CONTROL PANEL / DISCHARGE CHUTE

SNOW THROWER - MODEL NO. ST 3261 (96192010200), PRODUCT NO. 961 92 01-02

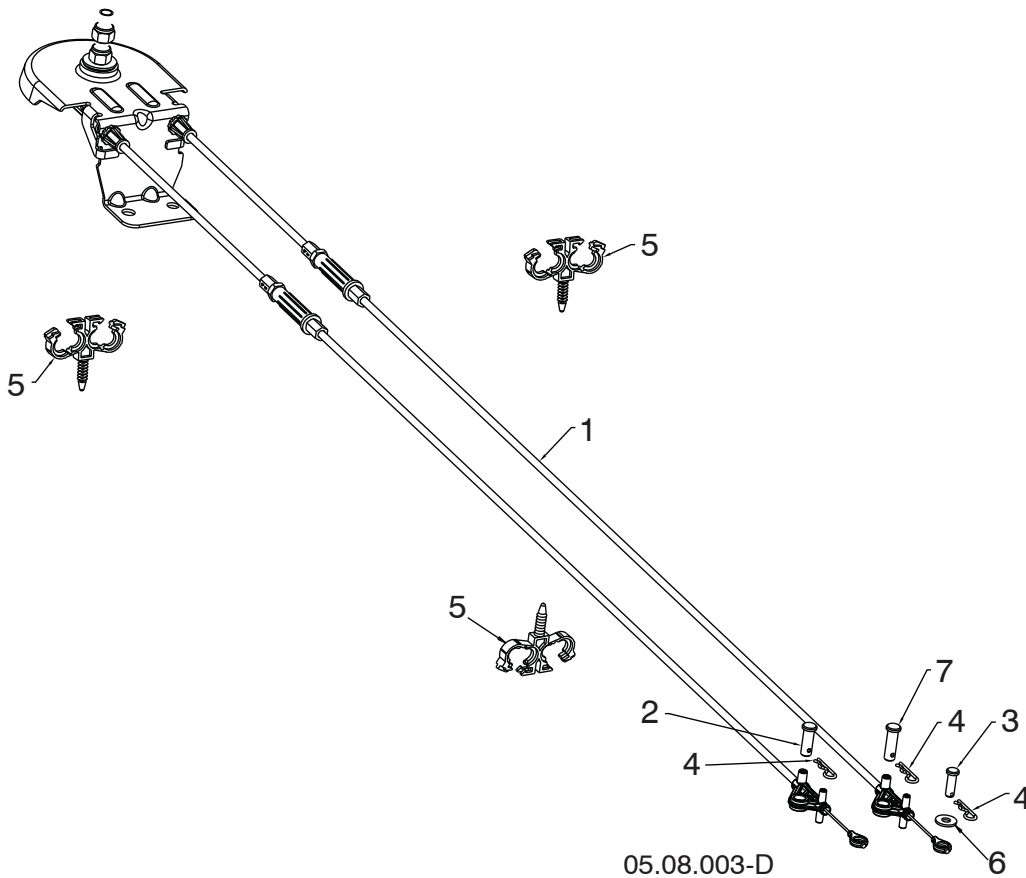

KEY NO.	PART NO.	DESCRIPTION
1	581 68 03-01	CABLE ROTATOR ASM
2	581 32 94-01	PIN CLEVIS 5/16 X 7/8
3	877 10 08-12	PIN CLEVIS 1/4 X 3/4
4	532 42 33-03	HAIRPIN SOFT ZINC
5	584 65 22-01	CLIP CONDUIT DOUBLE
6	586 68 21-01	WASHER
7	587 13 08-01	PIN CLEVIS 5/16 X 1

NOTE: All component dimensions given in U.S. inches. 1 inch = 25.4 mm
IMPORTANT: Use only Original Equipment Manufacturer (O.E.M.) replacement parts. Failure to do so could be hazardous, damage your snow thrower and void your warranty.

REPAIR PARTS

HANDLES

SNOW THROWER - MODEL NO. ST 3261 (96192010200), PRODUCT NO. 961 92 01-02

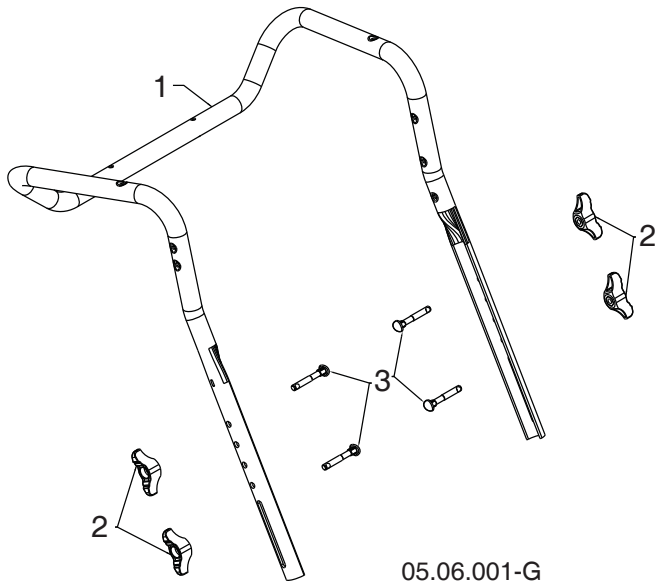

KEY NO.	PART NO.	DESCRIPTION
1	588 16 08-02	UPPER HANDLE
2	532 19 19-38	HANDLE KNOB STD BLACK
3	588 05 99-01	SCREW 5/16-18 X 2.25 CONCAVE HEAD WITH PATCH

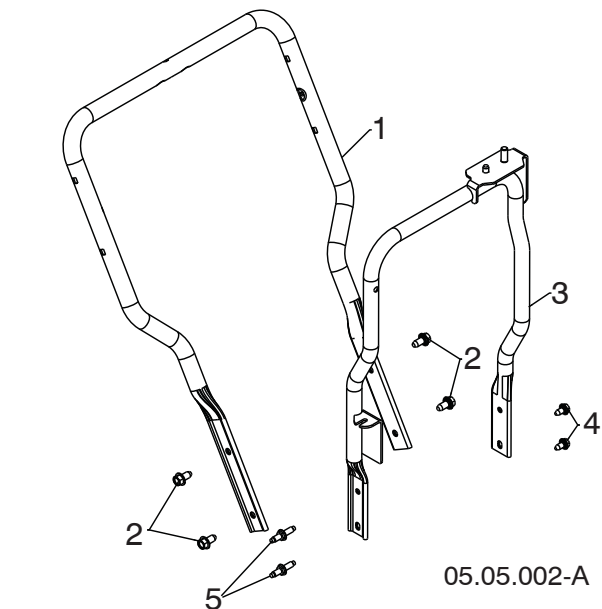

KEY NO.	PART NO.	DESCRIPTION
1	588 67 21-02	LOWER HANDLE
2	517 00 06-12	SCREW HEX WASH HD 3/8-16 X .75
3	589 26 45-02	CHUTE ROTATOR SUPPORT ASM
4	517 00 05-10	BOLT HEX 5/16-18
5	582 91 79-01	STUD - BOLTED HEX HEAD

NOTE: All component dimensions given in U.S. inches. 1 inch = 25.4 mm
IMPORTANT: Use only Original Equipment Manufacturer (O.E.M.) replacement parts.
 Failure to do so could be hazardous, damage your snow thrower and void your warranty.

REPAIR PARTS

DRIVE

SNOW THROWER - MODEL NO. ST 3261 (96192010200), PRODUCT NO. 961 92 01-02

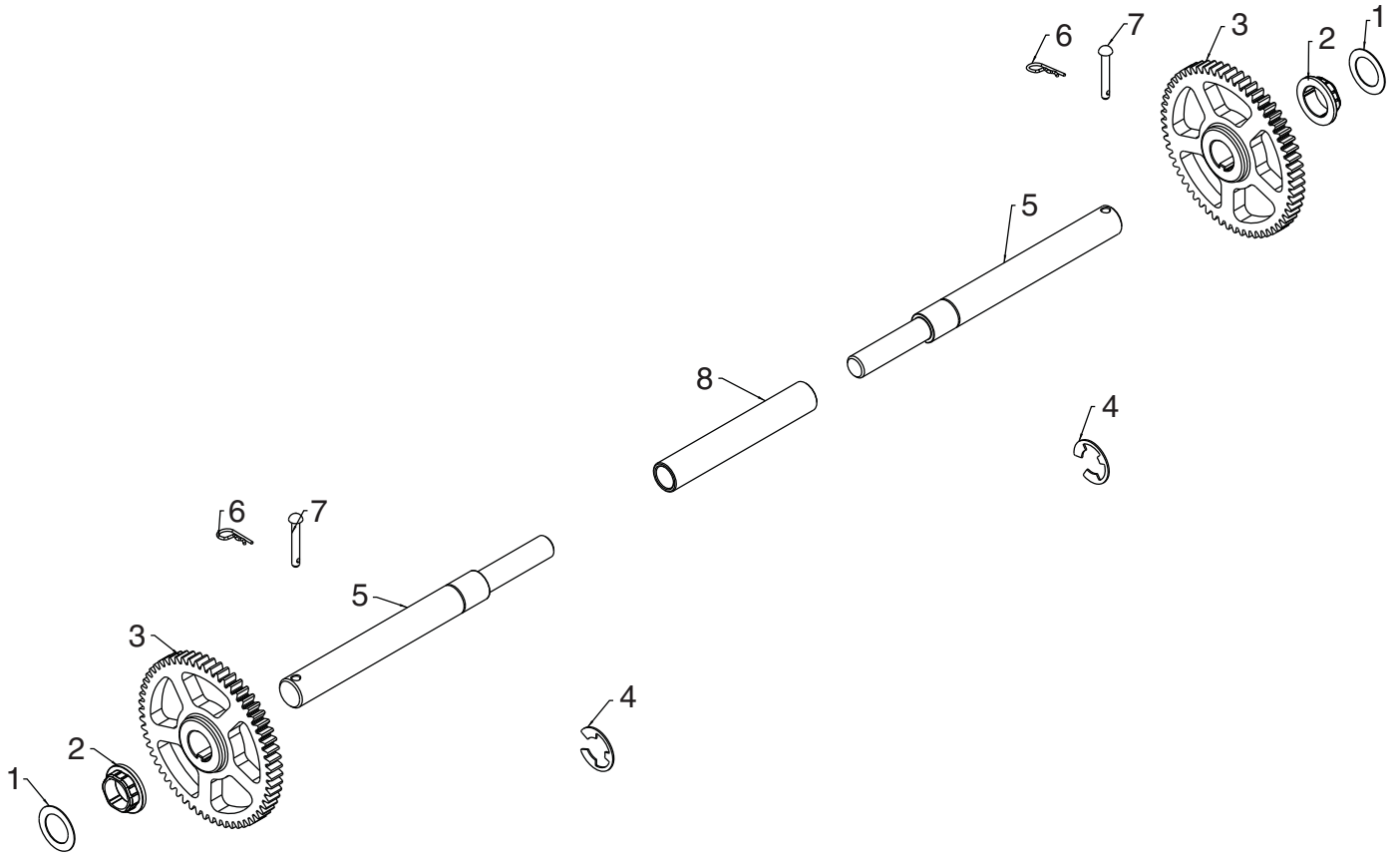

05.03.002-B

KEY NO.	PART NO.	DESCRIPTION
1	532 44 49-49	WASHER 1.00
2	587 97 89-01	BUSHING HEX 1 SHAFT
3	588 51 86-01	GEAR 59T DRIVEN
4	812 00 00-53	RETAINING RING
5	580 75 26-01	AXLE SHAFT SPLIT
6	532 12 47-88	RETAINER SPRING 1 ZINC
7	532 17 12-71	RIVET RD HD DRILLED 1/4 DIA
8	580 75 25-01	AXLE SLEEVE

NOTE: All component dimensions given in U.S. inches. 1 inch = 25.4 mm
IMPORTANT: Use only Original Equipment Manufacturer (O.E.M.) replacement parts.
Failure to do so could be hazardous, damage your snow thrower and void your warranty.

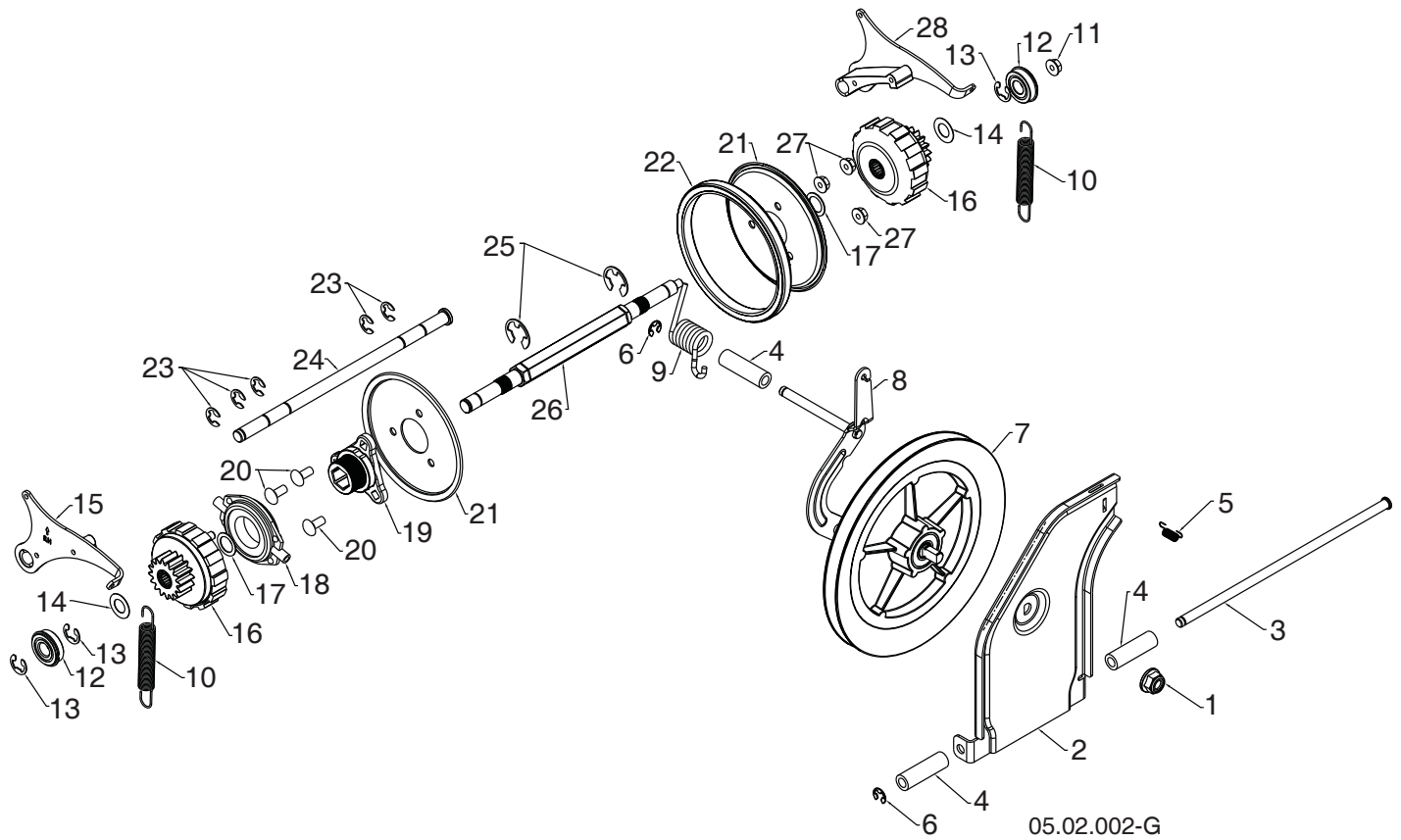

NOTE: All component dimensions given in U.S. inches. 1 inch = 25.4 mm
IMPORTANT: Use only Original Equipment Manufacturer (O.E.M.) replacement parts.
 Failure to do so could be hazardous, damage your snow thrower and void your warranty.

SNOW THROWER - MODEL NO. **ST 3261** (96192010200), PRODUCT NO. 961 92 01-02

KEY NO.	PART NO.	DESCRIPTION
1	521 99 11-01	NUT HEX FLANGE LK 1/2-13
2	587 70 34-02	SWING PLATE FRICTION PULL
3	581 12 30-01	ROD TIP PLATE
4	581 73 27-01	SPACER DRIVE
5	532 19 38-85	LATCH SPRING
6	812 00 00-07	E-RING RETAINER
7	581 32 84-01	FRICTION DISC COMBO PULLEY
8	587 19 34-03	BRACKET YOKE ASSEMBLY
9	581 31 53-01	SPRING TORSION DRIVE
10	585 26 38-01	EXTENSION SPRING
11	585 69 15-01	NUT HEX FLANGE LOCK 5/16-18
12	580 75 62-01	BEARING 9/16 I.D. 1622-2RSNR
13	580 75 61-02	RETAINING RING 1622-2RSNR
14	580 75 13-01	WASHER FLAT .59 I.D. X 1.065 X 25 GA
15	580 75 66-01	PAWL ASM RH
16	580 75 60-01	GEAR ASM PLANETARY
17	580 75 63-01	WASHER FLAT .6875 I.D. X 1.00 X 21 GA
18	532 17 53-44	TRUNNION BEARING ASM
19	581 09 09-01	HUB RUBBER WHEEL
20	872 11 05-06	BOLT CARRIAGE 5/16-18 X .75
21	581 09 10-02	PLATE RUBBER WHEEL
22	581 09 11-01	RING RUBBER WHEEL
23	586 64 43-01	E-RING
24	580 75 51-01	ROD PAWL
25	812 00 00-22	E-RING
26	580 75 24-01	SHAFT REDUCTION PWR STR
27	532 75 11-53	NUT HEX FLANGE LK 5/16-18
28	580 75 67-01	PAWL ASM LH

NOTE: All component dimensions given in U.S. inches. 1 inch = 25.4 mm
IMPORTANT: Use only Original Equipment Manufacturer (O.E.M.) replacement parts.
 Failure to do so could be hazardous, damage your snow thrower and void your warranty.

REPAIR PARTS

CHASSIS / ENGINE / PULLEYS

SNOW THROWER - MODEL NO. ST 3261 (96192010200), PRODUCT NO. 961 92 01-02

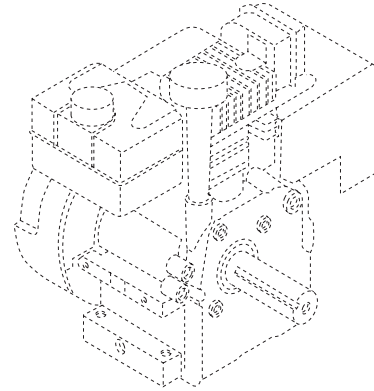
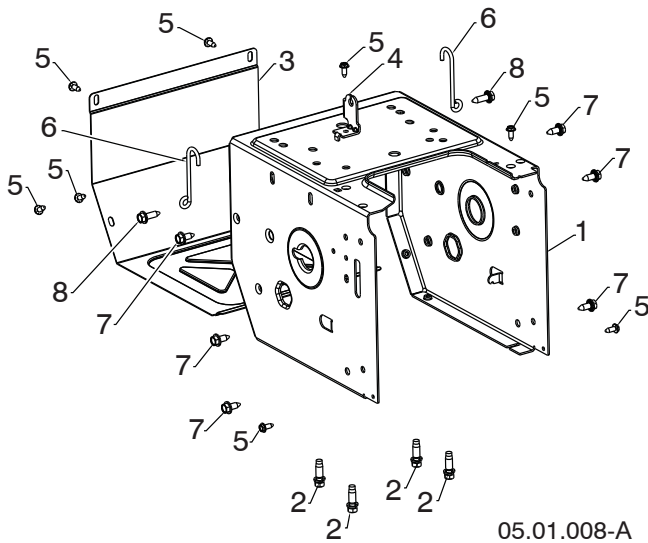

KEY NO.	PART NO.	DESCRIPTION
--	585 33 57-06	COMPLETE LCT ENGINE PW2HK18650178E
3	589 26 47-07	FRAME
2	532 15 04-06	ENGINE BOLT 3/8-16 X 1.280 DOGPOINT
3	580 83 95-07	FRAME COVER
4	501 06 04-03	SHIFTER BRACKET
5	582 90 69-01	SCREW HEX WASHER 1/4-20 X 5/8
6	588 95 45-01	WIREFORM SUPPORT CABLE
6	532 42 88-67	BOLT HEXHD WASHER 5/16-18 X .75
7	585 21 75-01	BOLT HEXHD WASHER 5/16-18 X 1.00

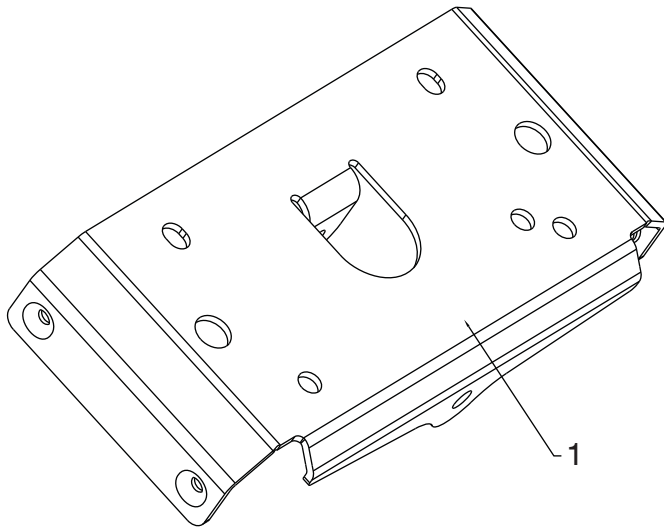

KEY NO.	PART NO.	DESCRIPTION
1	583 94 05-02	SMALL MOUNTING PLATE

NOTE: All component dimensions given in U.S. inches. 1 inch = 25.4 mm
IMPORTANT: Use only Original Equipment Manufacturer (O.E.M.) replacement parts. Failure to do so could be hazardous, damage your snow thrower and void your warranty.

REPAIR PARTS

CHASSIS / ENGINE / PULLEYS

SNOW THROWER - MODEL NO. ST 3261 (96192010200), PRODUCT NO. 961 92 01-02

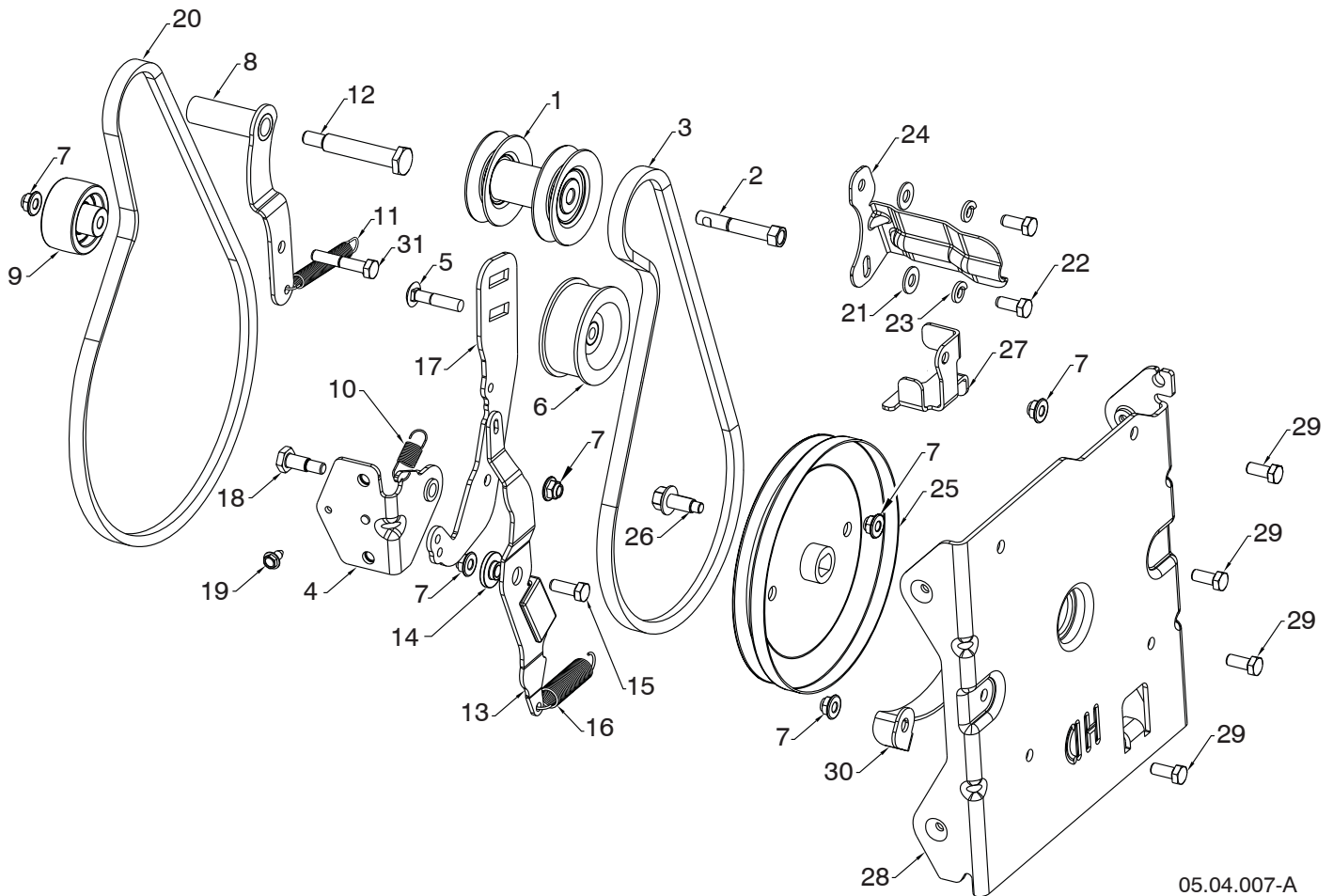

KEY NO.	PART NO.	DESCRIPTION	KEY NO.	PART NO.	DESCRIPTION
1	587 89 37-03	PULLEY ENGINE	16	579 76 35-01	SPRING EXTENSION BRAKE
2	582 38 84-01	BOLT	17	589 26 29-02	ARM IDLER
3	501 81 82-01	BOLT	18	589 26 36-01	SCREW HEX HEAD SHOULDER
4	589 26 34-02	BRACKET WELDMENT IDLER ARM	19	817 06 04-08	SCREW
5	589 28 45-01	BOLT CARRIAGE 5/16-18	20	584 21 61-02	BELT 4L
6	589 26 27-01	PULLEY IDLER	21	819 11 12-16	WASHER
7	532 42 79-42	NUT	22	874 61 05-12	SCREW
8	581 33 82-03	ARM DRIVE IDLER	23	810 04 05-00	WASHER
9	586 88 02-01	PULLEY IDLER FLANGELESS 2.0	24	588 49 28-01	BELT KEEPER BRACKET
10	589 26 37-01	SPRING IDLER RETURN	25	589 36 92-01	PULLEY IMPELLER DD 4L HD
11	580 75 30-01	SPRING	26	583 81 49-01	SCREW FLANGE HEAD CAP WITH DOG POINT 3/8-16
12	581 41 38-01	BOLT	27	587 58 72-02	GUIDE BELT 4L
13	579 76 33-01	ARM IMPELLER BRAKE HD	28	501 59 54-02	INTERFACE BRACKET
14	587 34 37-01	BUSHING	29	874 78 05-12	SCREW
15	874 76 05-14	BOLT	30	581 63 20-02	LOWER BELT KEEPER
			31	874 76 05-28	SCREW 5/16-18 X 1.75

NOTE: All component dimensions given in U.S. inches. 1 inch = 25.4 mm
IMPORTANT: Use only Original Equipment Manufacturer (O.E.M.) replacement parts.
 Failure to do so could be hazardous, damage your snow thrower and void your warranty.

REPAIR PARTS

CHASSIS / ENGINE / PULLEYS

SNOW THROWER - MODEL NO. ST 3261 (96192010200), PRODUCT NO. 961 92 01-02

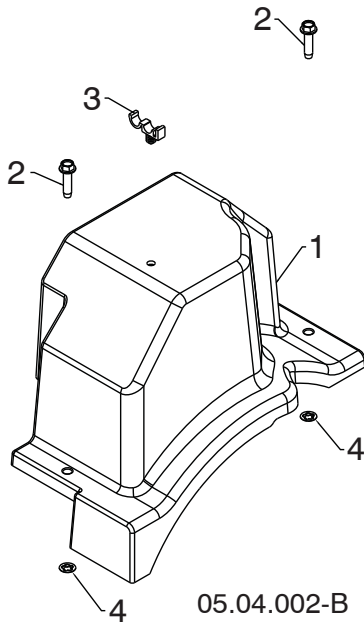

KEY NO.	PART NO.	DESCRIPTION
1	587 10 54-01	BELT COVER BLACK ASSEMBLY (INCLUDES 2 & 4)
2	-----	BOLT HEX WSH THDRL 1/4-20 X 1
3	532 14 50-06	CABLE GUIDE
4	-----	PALNUT 1/4 IN

NOTE: All component dimensions given in U.S. inches. 1 inch = 25.4 mm
IMPORTANT: Use only Original Equipment Manufacturer (O.E.M.) replacement parts. Failure to do so could be hazardous, damage your snow thrower and void your warranty.

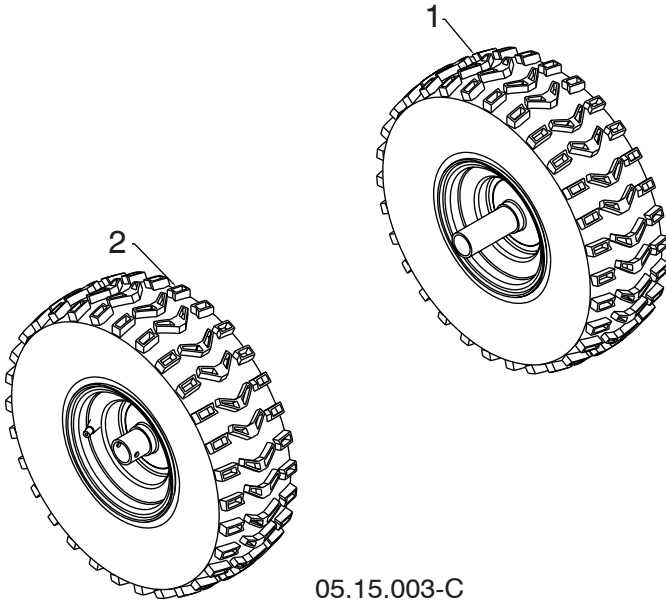

KEY NO.	PART NO.	DESCRIPTION
1	586 71 04-01	WHEEL 15X5.00 NPS LH 1.00 K478
2	586 71 03-01	WHEEL 15X5.00 NPS RH 1.00 K478

05.15.003-C

NOTE: All component dimensions given in U.S. inches. 1 inch = 25.4 mm
IMPORTANT: Use only Original Equipment Manufacturer (O.E.M.) replacement parts. Failure to do so could be hazardous, damage your snow thrower and void your warranty.

REPAIR PARTS

BAG OF PARTS

SNOW THROWER - MODEL NO. ST 3261 (96192010200), PRODUCT NO. 961 92 01-02

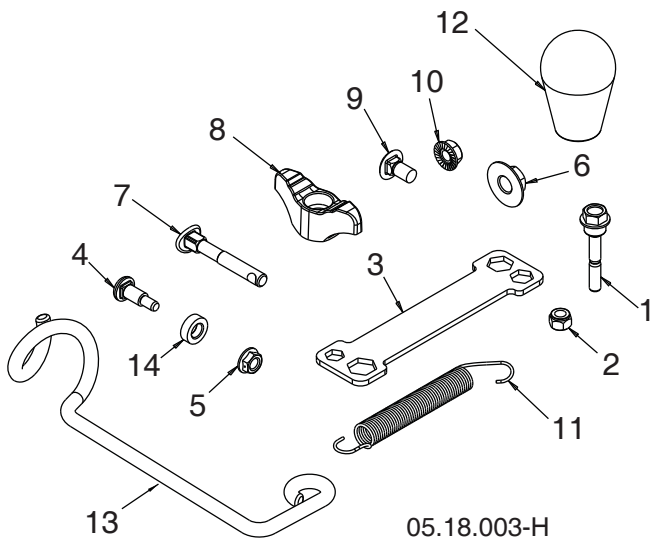

KEY NO.	PART NO.	DESCRIPTION
1	588 07 75-01	BOLT 1/4-20 X 1.81
2	873 80 04-00	NUT NYLOCK 1/4-20
3	532 18 06-84	WRENCH
4	501 41 73-01	BOLT SHOULDER
5	585 69 14-01	NUT HEX FL 1/4-20 CTR
6	585 69 10-01	NUT NYLOCK 3/8-16
7	588 05 99-01	BOLT 5/16-18 X 2.25 CONCAVE
8	532 19 19-38	KNOB 5/16-18 TWO-WING
9	585 83 20-01	BOLT 5/16-18 X .625
10	873 97 05-00	NUT SERR FL LOCK 5/16-18
11	532 18 45-05	SPRING DEFLECT CHUTE
12	581 69 75-01	KNOB SOFT TOUCH SLOTTED
13	581 89 73-01	SUPPORT ROTATION CABLE
14	501 41 74-01	WASHER NYLON
NI	580 94 77-05	BAG PLASTIC 6.5 X 10.5
		WARNING
NI	588 07 76-03	KIT REPLACEMENT BAG OF PARTS

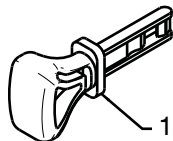

01.14.009-B

KEY NO.	PART NO.	DESCRIPTION
1	532 44 30-59	SAFETY IGNITION KEY KIT

NOTE: All component dimensions given in U.S. inches. 1 inch = 25.4 mm
IMPORTANT: Use only Original Equipment Manufacturer (O.E.M.) replacement parts. Failure to do so could be hazardous, damage your snow thrower and void your warranty.



1



3



2



4

KEY NO.	PART NO.	DESCRIPTION
1	532 18 40-45	DECAL AUGER
2	590 81 22-01	DECAL CHUTE
3	532 19 96-83	DECAL AUGER SAFETY
4	532 18 40-28	DECAL BELT GUIDE

05.16.001-A

NOTE: All component dimensions given in U.S. inches. 1 inch = 25.4 mm
IMPORTANT: Use only Original Equipment Manufacturer (O.E.M.) replacement parts. Failure to do so could be hazardous, damage your snow thrower and void your warranty.

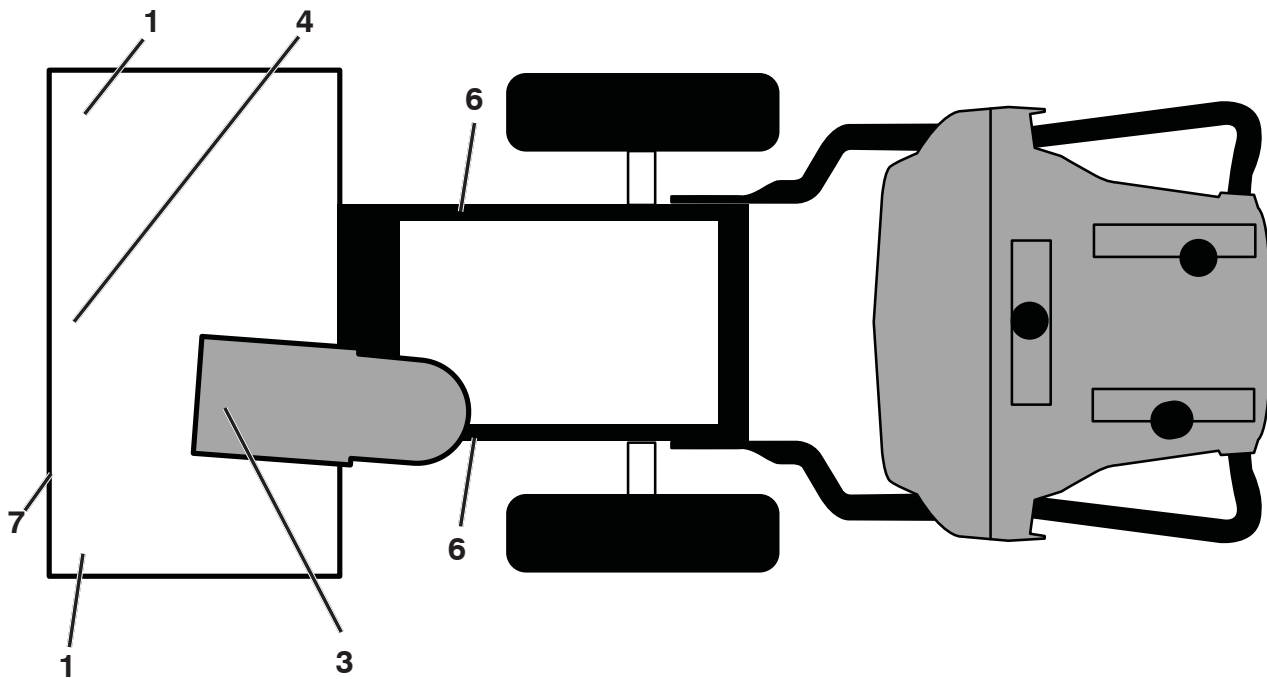

**KEY PART
NO. NO.**

DESCRIPTION

1	532 19 96-83	DECAL, DANGER
3	590 81 22-01	DECAL, DANGER, DEFLECTOR CHUTE
4	532 18 40-45	DECAL, DANGER
6	532 18 40-28	DECAL, BELT GUIDE
7	594 02 93-01	DECAL, AUGER FRONT
--	593 96 84-01	DECAL, ENGINE REWIND (NOT SHOWN)
--	115 99 60-49	OPERATOR'S MANUAL, ENGLISH, FRENCH, SPANISH

NOTE: All component dimensions given in U.S. inches. 1 inch = 25.4 mm

IMPORTANT: Use only Original Equipment Manufacturer (O.E.M.) replacement parts. Failure to do so could be hazardous, damage your snow thrower and void your warranty.

ENGINE, LCT

COMPLETE ENGINE-585335705

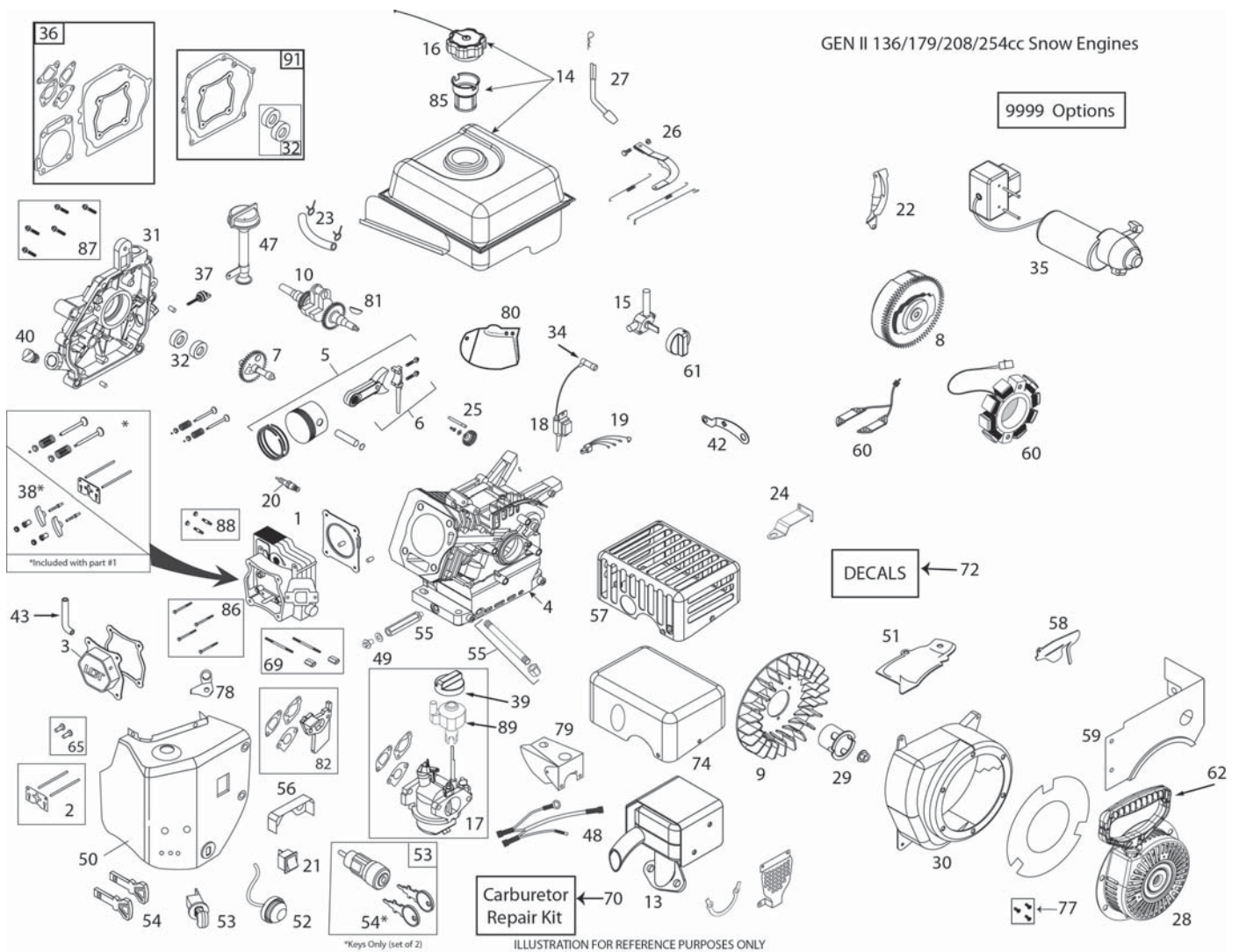

KEY PART NO.	NO.	DESCRIPTION
1	585 77 14-01	CYLINDER HEAD ASSEMBLY - 254CC (INCL. GASKET)
2	585 77 15-01	PUSH ROD & PLATE KIT (254CC) (INCL. VALVE COVER GSKT)
3	585 77 16-01	VALVE COVER (254CC) (INCL. GASKET)
4	N/A	N/A
5	585 77 17-01	PISTON & ROD ASSEMBLY (254CC)
6	N/A	N/A
7	585 77 18-01	CAMSHAFT - MCR (254CC)
8	585 77 19-01	FLYWHEEL - ELECTRIC START (8-CHARGING MAGNETS) (254CC)
9	532 42 05-86	COOLING FAN - FLYWHEEL (PLASTIC - 208CC)
10	585 77 20-01	CRANKSHAFT (#18 KEYED 254CC SNOW)

KEY PART NO.	NO.	DESCRIPTION
13	582 58 29-01	MUFFLER ASSEMBLY-GEN LL SNOW (254CC)
14	585 77 22-01	FUEL TANK (SNOW) (2.7L BLACK 254CC)
15	532 42 92-34	FUEL TANK ON/OFF VALVE (PETCOCK) - GEN II SNOW
16	532 42 49-42	FUEL TANK CAP - BLACK CLICK STYLE (VENTED)
17	585 77 23-01	CARBURETOR (L15) (254CC SNOW)
18	532 44 39-34	IGNITION COIL (CDI) (208CC) (STANDARD)
19	N/A	N/A
20	532 44 38-98	SPARK PLUG - PLATINUM
21	532 42 49-57	ON/OFF SWITCH - ROCKER
22	585 77 24-01	SHIELD - FLYWHEEL (ELECTRIC 208CC)

ENGINE, LCT**COMPLETE ENGINE-585335705**

KEY NO.	PART NO.	DESCRIPTION	KEY NO.	PART NO.	DESCRIPTION
23	532 43 80-14	FUEL HOSE KIT (1/4' ID)	55	532 43 26-86	OIL DRAIN TUBE-SNOW (136/208CC)
24	585 77 25-01	SPEED CONTROL BRACKET (FIXED)(254CC SNOW)	56	585 77 33-01	CARBURETOR VAPOR SHIELD (254CCSNOW)
25	532 42 96-46	GOVERNOR GEAR ASSEMBLY (136/208CC)	57	532 43 66-72	CE COMPLIANT MUFFLER SHIELD
26	585 77 26-01	GOVERNOR ARM & LINK KIT (254CC SNOW)	58	585 77 34-01	SHIELD - GOVERNOR LINKAGE (254CC-SNOW)
27	532 42 06-02	GOVERNOR ARM PADDLE	59	587 15 45-01	FUEL TANK SKIRT (254CC SNOW)
28	532 43 69-67	RECOIL STARTER ASSY(ROUND-BLACK)SNOW	60	532 44 38-93	CHARGING COIL (60-WATT AC) (208/254CC)
29	532 43 69-68	STARTER CUP (USE WITH ROUND STYLE STARTER)	61	532 43 27-52	FUEL CONTROL KNOB (GEN II SNOW - RED)
30	581 19 20-01	BLOWER HOUSING - BLACK ELECTRIC START (254CC)	62	532 44 38-99	STARTER GRIP-SNOW (DELUXE)
31	585 77 27-01	CRANKCASE COVER (PRESS-IN TYPE HIGH OIL-FILL TUBE)	65	581 37 28-01	TAPPET KIT (208/254CC)(SET OF 2)
32	585 77 28-01	OIL SEAL KIT (2 PCS)	69	532 42 49-51	CARBURETOR STUDS & COUPL-LNG KIT-SNOW
34	532 43 69-66	SPARK PLUG BOOT - WITH METAL SHIELD (SNOW)	70	580 35 36-01	CARBURETOR REPAIR KIT (136/208/254CC)
35	532 43 64-66	120V ELECTRIC STARTER (208/254CC GEN LL) (SIDE MOUNT)	72	N/A	N/A
36	585 77 29-01	ENGINE GASKET KIT (254CC) (DOES NOT INCLUDE OIL SEALS)	74	582 55 23-01	MUFFLER HEAT SHIELD COVER (136/208/254)
37	N/A	N/A	77	532 43 26-88	RECOIL BOLT KIT (3 BOLTS PER KIT)
38	585 77 30-01	ROCKER ARM KIT (254CC)(INCL. GASKET)	78	N/A	N/A
39	532 42 92-24	CHOKE CONTROL KNOB (GEN II RED)	79	585 77 37-01	CARBURETOR COVER (136CC SNOW)
40	532 42 95-98	NON-REMOVABLE PLASTIC PLUG (136/208/254CC)	80	585 77 38-01	SHIELD GOVERNOR LINK - 254CC SNOW
42	N/A	N/A	81	585 29 72-01	WOODRUFF FLYWHEEL KEYS (5-PACK) (5X6X18MM)
43	580 35 34-01	BREATHER TUBE (136/208/254CC)	82	585 02 05-03	208CC/254CC CARBURETOR SPACER KIT
47	581 00 72-01	HIGH OIL-FILL TUBE/DIPSTICK (PRESS-IN TYPE)	85	586 32 56-01	FUEL TANK STRAINER
48	532 42 92-84	WIRE HARNESS (208/254CC SNOW)	86	586 32 73-01	CYLINDER HEAD BOLT KIT (4) (136-179-208-254CC)
49	532 43 54-95	OIL DRAIN PLUG W/WASHER (136/208/254CC)	87	586 32 69-01	CC COVER BOLT KIT (6) (179-208-254CC)
50	585 77 31-01	HEATER BOX KIT (254CC SNOW)	88	586 32 68-01	MUFFLER MTG STUD KIT (2)
51	585 77 32-01	CYLINDER COVER SHIELD	89	N/A	N/A
52	532 42 49-49	PRIMER BULB WITH HOSE-SNOW	91	587 99 41-02	CRANKSHAFT GASKET KIT 254CC
53	532 42 49-54	SAFETY KEY SWITCH -SNOW (INCL. KEYS)	9999	587 15 48-01	HIGH ALTITUDE JET (>6,000 FEET)(254CC L15 CARBURETOR)
54	532 44 30-59	KEY SET - RED (2) (SNOW)	9999	579 80 64-01	BOLT KIT - BLWR HGS/HEATER BOX/TANK SKIRT