

ILLUSTRATED PARTS LIST

MODEL NUMBER 96192010600

PRODUCT NUMBER **DST24**

MFG. ID. NUMBER 961 92 01-06

REPAIR PARTS

AUGER HOUSING / IMPELLER ASSEMBLY

SNOW THROWER - MODEL NO. DST24 (96192010600), PRODUCT NO. 961 92 01-06

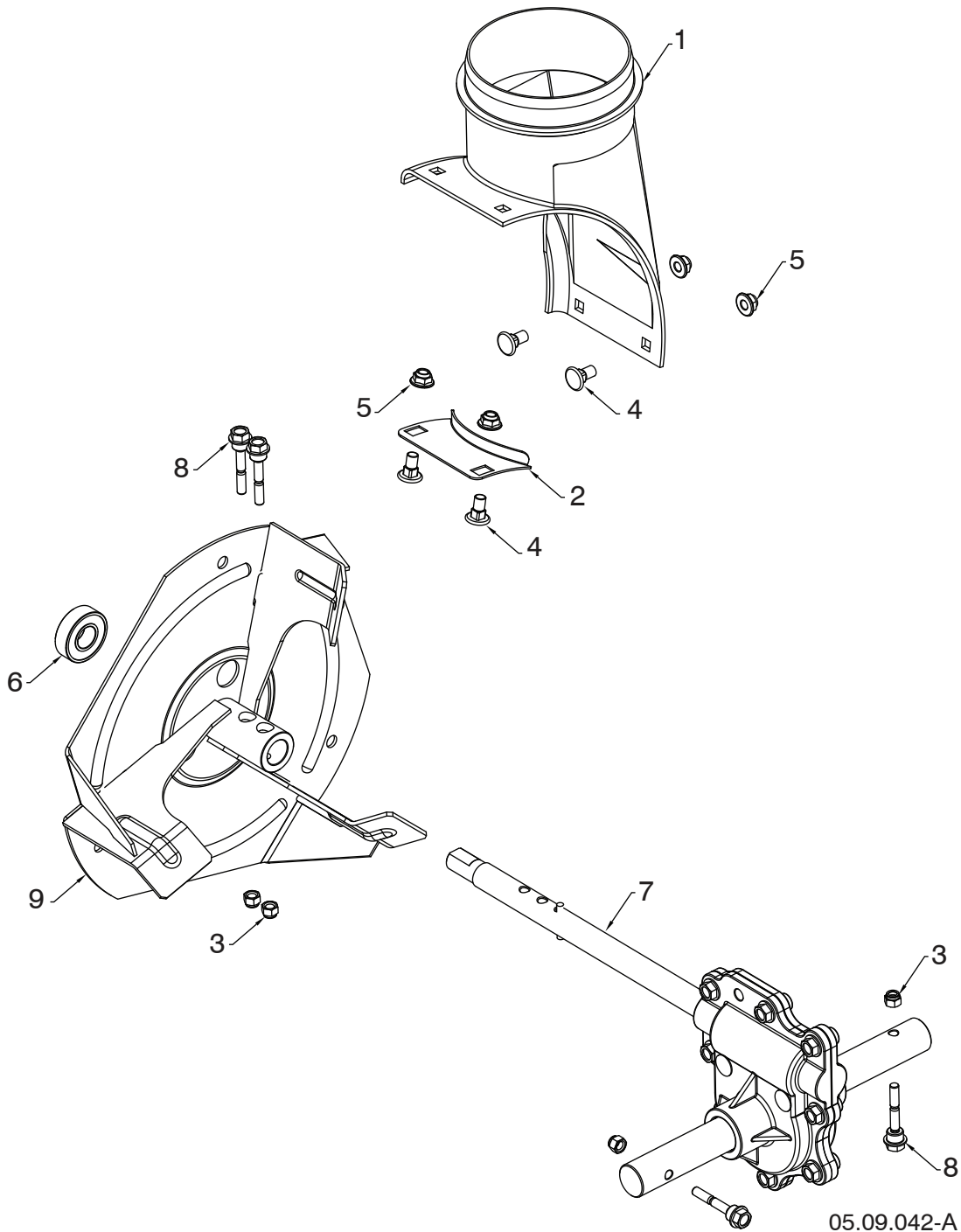

NOTE: All component dimensions given in U.S. inches. 1 inch = 25.4 mm
IMPORTANT: Use only Original Equipment Manufacturer (O.E.M.) replacement parts. Failure to do so could be hazardous, damage your snow thrower and void your warranty.

REPAIR PARTS**AUGER HOUSING / IMPELLER ASSEMBLY****SNOW THROWER - MODEL NO. DST24 (96192010600), PRODUCT NO. 961 92 01-06**

KEY NO.	PART NO.	DESCRIPTION
1	585 05 69-01	CHUTE DISCAHRGE BASE
2	532 18 40-95	BRACKET CORNER DISCHARGE YZP
3	873 80 04-00	NUT NYLOCK 1/4 - 20
4	585 69 12-01	BOLT CAR WAF BLK 5/16-18 X .488
5	585 69 13-01	NUT HEX FLANGE 5/16-18 NYLOCK
6	532 19 87-91	BEARING 1501389 BALL
7	582 86 76-01	TRANSMISSION GEARBOX ALUM DD
8	588 07 75-01	BOLT 1/4-20 X 1-13/16 SHEAR
9	586 60 72-02	IMPELLER STEEL SNOW 479

NOTE: All component dimensions given in U.S. inches. 1 inch = 25.4 mm
IMPORTANT: Use only Original Equipment Manufacturer (O.E.M.) replacement parts.
Failure to do so could be hazardous, damage your snow thrower and void your warranty.

REPAIR PARTS

AUGER HOUSING / IMPELLER ASSEMBLY

SNOW THROWER - MODEL NO. DST24 (96192010600), PRODUCT NO. 961 92 01-06

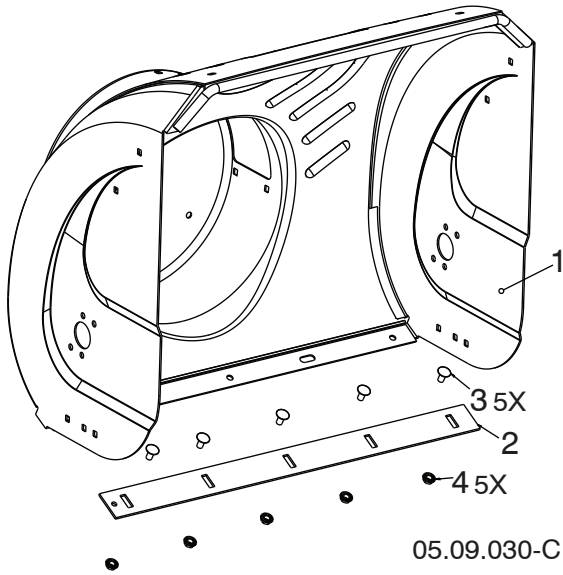

KEY NO.	PART NO.	DESCRIPTION
1	588 61 02-45	AUGER HOUSING
2	532 40 78-25	SCRAPER BAR
3	872 27 05-05	CARRIAGE BOLT 5/16-18 X .625 GR5
4	532 15 53-77	NUT 5/16-18

05.09.030-C

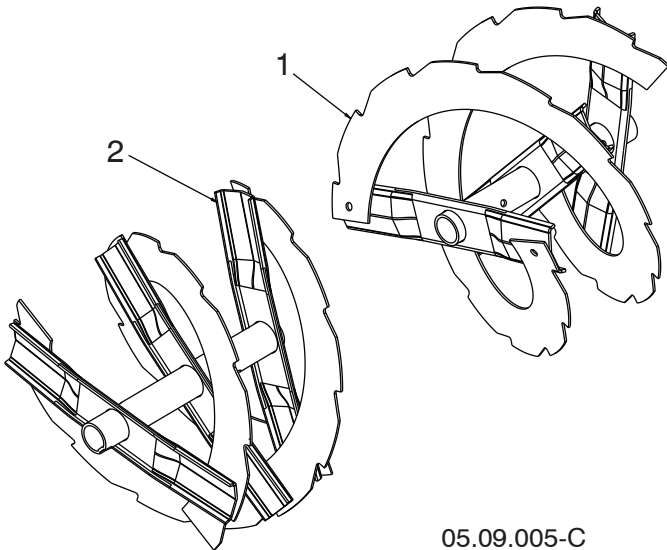

KEY NO.	PART NO.	DESCRIPTION
1	532 42 10-72	AUGER WELD RIB LH 24
2	532 42 10-73	AUGER WELD RIB RH 24

05.09.005-C

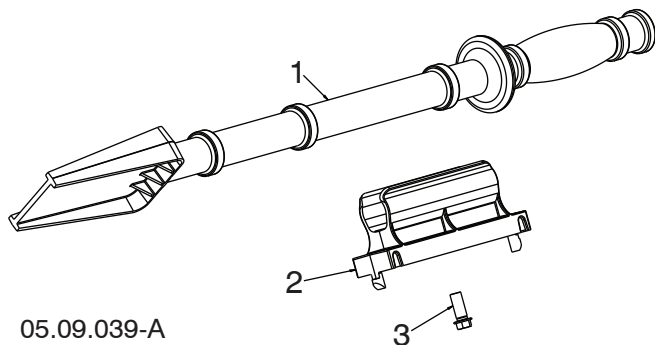

KEY NO.	PART NO.	DESCRIPTION
1	532 19 21-99	TOOL CLEANOUT
2	532 40 54-00	CLIP CLEANOUT TOOL
3	532 19 41-89	SCREW HEX WASHER 13-16 X 5/8

05.09.039-A

NOTE: All component dimensions given in U.S. inches. 1 inch = 25.4 mm
IMPORTANT: Use only Original Equipment Manufacturer (O.E.M.) replacement parts. Failure to do so could be hazardous, damage your snow thrower and void your warranty.

REPAIR PARTS

AUGER HOUSING / IMPELLER ASSEMBLY

SNOW THROWER - MODEL NO. DST24 (96192010600), PRODUCT NO. 961 92 01-06

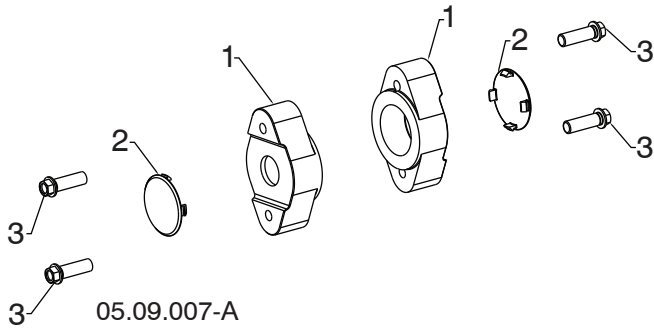

KEY NO.	PART NO.	DESCRIPTION
1	532 42 04-78	AUGER BEARING
2	532 41 19-39	BEARING PLUG
3	584 29 94-01	SCREW HI-LO WASHD 5/16-14 X 1.00

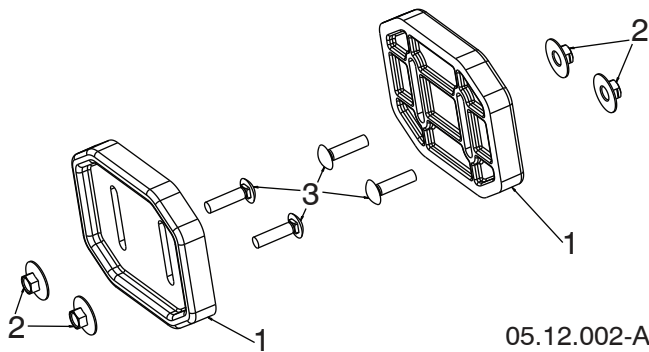

KEY NO.	PART NO.	DESCRIPTION
1	532 43 59-51	PLATE SKID PLASTIC HDPE
2	585 80 28-01	NUT LARGE FLANGE 5/16-18 - BLK
3	585 80 29-01	BOLT CARRIAGE 5/16-18 X 1.25 - BLK

NOTE: All component dimensions given in U.S. inches. 1 inch = 25.4 mm
IMPORTANT: Use only Original Equipment Manufacturer (O.E.M.) replacement parts.
 Failure to do so could be hazardous, damage your snow thrower and void your warranty.

REPAIR PARTS

CONTROL PANEL / DISCHARGE CHUTE

SNOW THROWER - MODEL NO. DST24 (96192010600), PRODUCT NO. 961 92 01-06

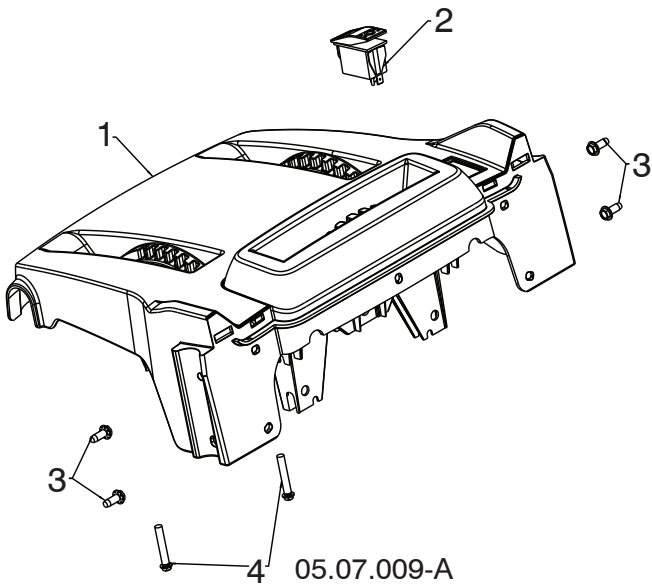

KEY NO.	PART NO.	DESCRIPTION
1	581 13 12-03	CONSOLE BASE MULTICONT W/SWITCH
2	585 80 50-01	SWITCH GRIP HEATED BLACK
3	817 06 04-10	SCREW TA SEMI GIMLE 1/4-20 X .62
4	581 32 95-01	SCREW HEX WASHER 13-16 X 1.50

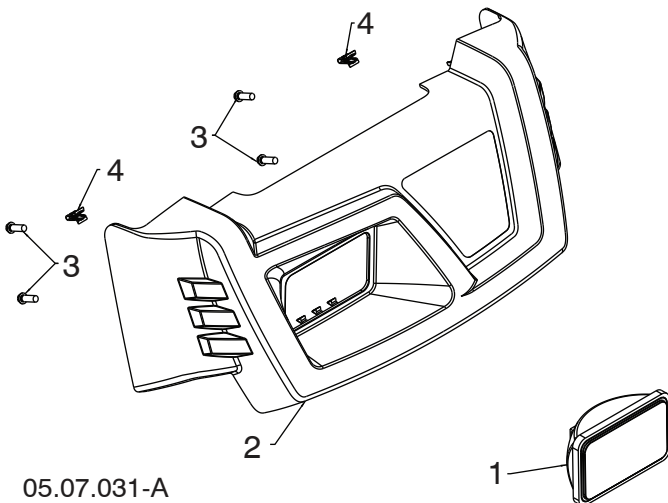

KEY NO.	PART NO.	DESCRIPTION
1	586 18 10-01	FLOOD HEADLIGHT
2	581 12 81-19	CONSOLE COVER REDMAX
3	532 19 41-89	SCREW HI-LO 13-16 X 5/8
4	581 92 87-01	PANEL CLIP
--	532 18 37-84	BULB (NOT SHOWN)

NOTE: All component dimensions given in U.S. inches. 1 inch = 25.4 mm
IMPORTANT: Use only Original Equipment Manufacturer (O.E.M.) replacement parts. Failure to do so could be hazardous, damage your snow thrower and void your warranty.

REPAIR PARTS

CONTROL PANEL / DISCHARGE CHUTE

SNOW THROWER - MODEL NO. DST24 (96192010600), PRODUCT NO. 961 92 01-06

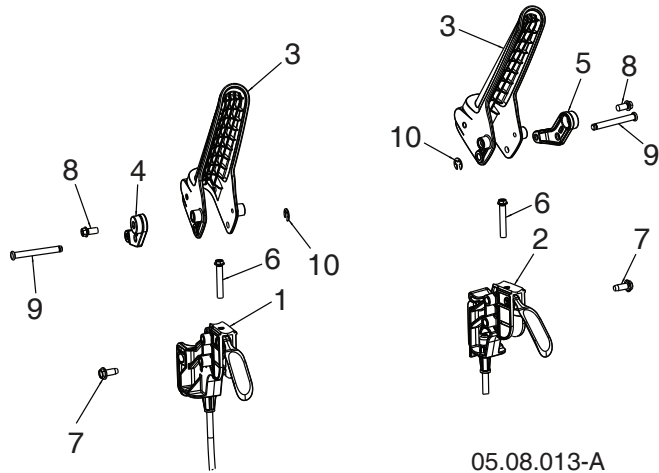

05.08.013-A

KEY NO.	PART NO.	DESCRIPTION
1	588 26 39-01	CABLE, POWER STEER - LHS
2	588 26 39-02	CABLE, POWER STEER - RHS
3	587 46 30-01	LEVER, CONTROL
4	587 73 97-01	LEVER, CABLE ARM - LHS
5	587 73 97-02	LEVER, CABLE ARM - RHS
6	581 32 95-01	SCREW HI-LO 13-16 X 1.50
7	817 06 04-10	SCREW 1/4-20 X .625
8	817 41 13-08	SCREW HI-LW 13-16 X .500
9	588 14 77-01	PIN, GROOVED
10	812 00 00-14	E-RING

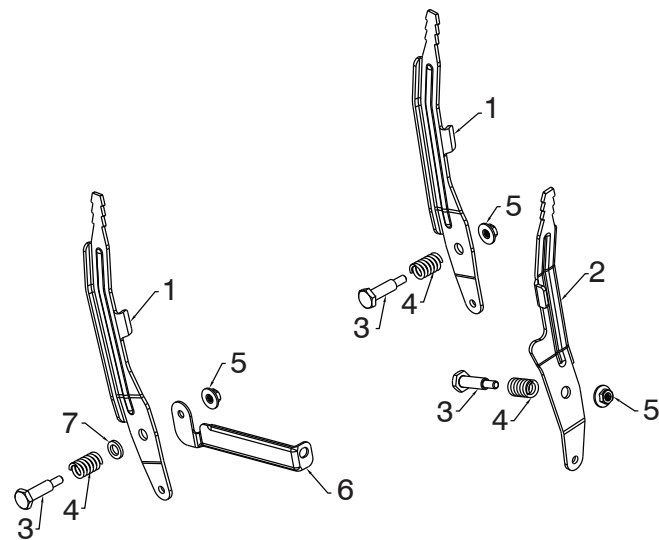

05.08.005-C

KEY NO.	PART NO.	DESCRIPTION
1	581 12 39-02	LEVER CONTROL SPEED/DEFL
2	581 24 16-02	LEVER CONTROL CHUTE ROT
3	581 32 97-01	BOLT SHOULDER 1/4-20
4	581 32 96-01	SPRING COMPRESSION
5	586 66 89-01	NUT FL LOCK 1/4-20
6	584 46 84-02	BRACE SUPPORT SPEED
7	587 03 13-01	WASHER .625 X .375 X .094 NYLON 6/6

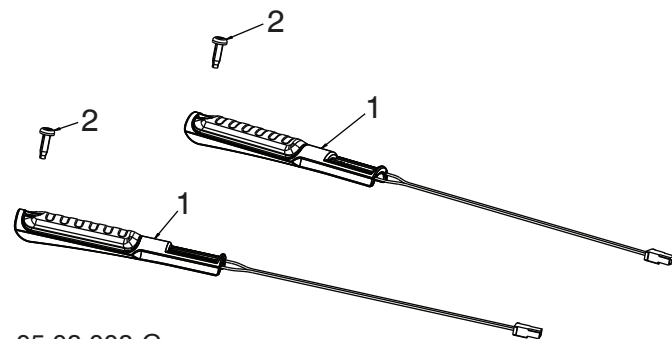

05.08.008-G

KEY NO.	PART NO.	DESCRIPTION
1	590 49 36-01	GRIP, HEATED, DSST SHO
2	532 44 22-50	SCREW PAN HD TORX 1/4-20 X .75

NOTE: All component dimensions given in U.S. inches. 1 inch = 25.4 mm
IMPORTANT: Use only Original Equipment Manufacturer (O.E.M.) replacement parts.
 Failure to do so could be hazardous, damage your snow thrower and void your warranty.

REPAIR PARTS

CONTROL PANEL / DISCHARGE CHUTE

SNOW THROWER - MODEL NO. DST24 (96192010600), PRODUCT NO. 961 92 01-06

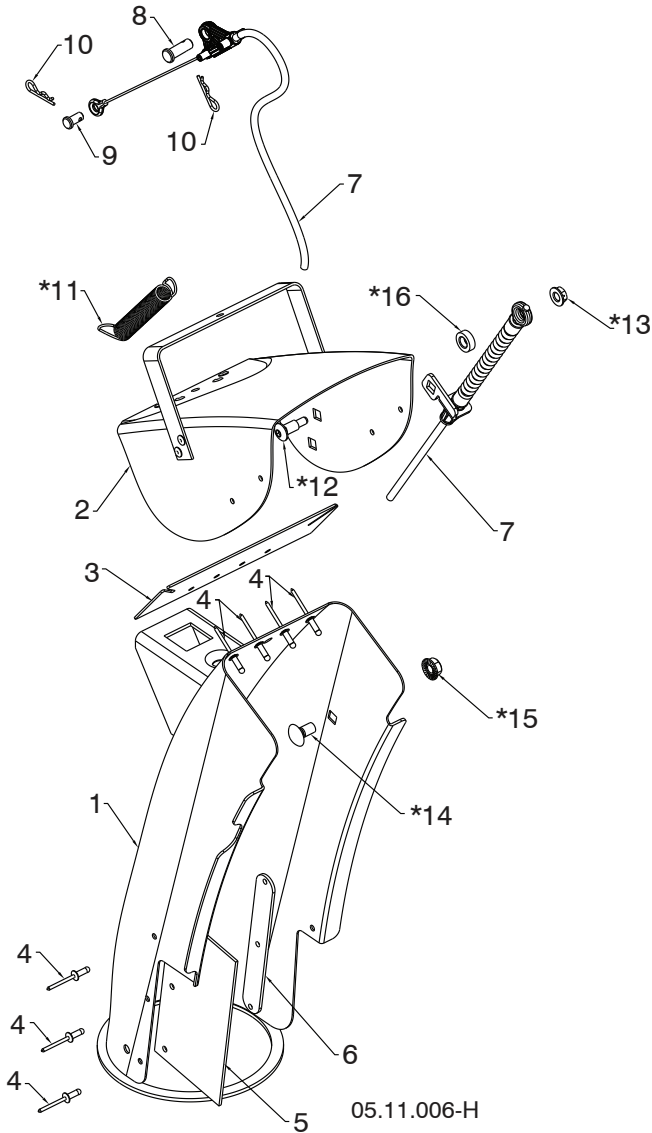

KEY NO.	PART NO.	DESCRIPTION
1	588 07 778-06	CHUTE WELDMENT ASSEMBLY (INCLUDES 1-6)
2	-----	RIVETED DEFLECTOR ASSEMBLY
3	-----	DEFLECTOR SEAL
4	-----	POP RIVET
5	-----	CHUTE SNOW SHIELD
6	-----	SHIELD STRAP RETAINER
7	590 58 70-01	CONTROL CHUTE DEFLECTOR BOWDEN
8	581 32 94-01	PIN CLEVIS 5/16 X .875
9	585 80 83-01	PIN CLEVIS 1/4 X .312
10	532 42 33-03	HAIRPIN RETAINER
*11	532 18 45-05	DEFLECTOR SPRING
*12	501 41 73-01	CARRIAGE BOLT 1/4-20 X .544
*13	585 69 14-01	NUT 1/4-20
*14	585 83 20-01	CARRIAGE BOLT 3/8-16 X .625
*15	873 97 05-00	NUT 5/16-18
*16	501 41 74-01	WASHER .362 X .625 X .205 NYLON

NOTE: ALL ITEMS MARKED WITH AN * ARE PROVIDED IN THE BAG OF ITEMS SHIPPED LOOSE WITH PRODUCT.

NOTE: All component dimensions given in U.S. inches. 1 inch = 25.4 mm
IMPORTANT: Use only Original Equipment Manufacturer (O.E.M.) replacement parts. Failure to do so could be hazardous, damage your snow thrower and void your warranty.

REPAIR PARTS

CONTROL PANEL / DISCHARGE CHUTE

SNOW THROWER - MODEL NO. DST24 (96192010600), PRODUCT NO. 961 92 01-06

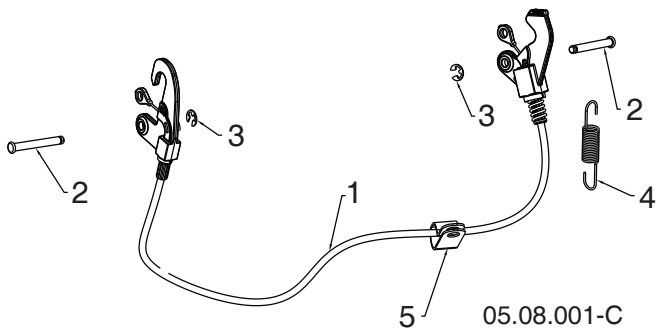

KEY NO.	PART NO.	DESCRIPTION
1	593 85 34-01	CABLE INTERLOCK
2	532 43 17-62	PIN GROOVED
3	812 00 00-14	E-RING
4	581 15 12-01	SPRING RETURN
5	532 19 79-91	CLIP CABLE BLACK

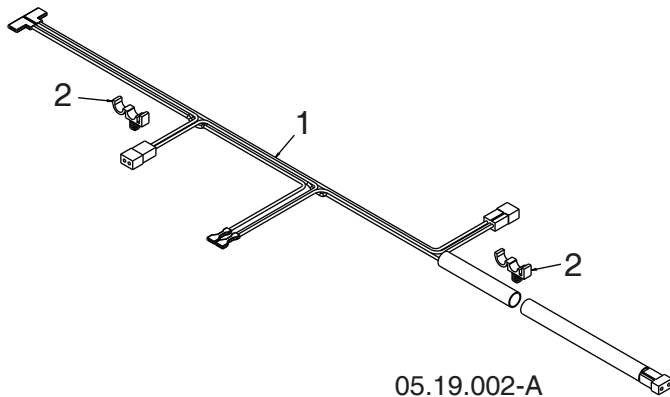

KEY NO.	PART NO.	DESCRIPTION
1	587 53 57-01	HARNESS WIRE LIGHTS & GRIPS
2	532 14 50-06	WIRE RETAINER

NOTE: All component dimensions given in U.S. inches. 1 inch = 25.4 mm
IMPORTANT: Use only Original Equipment Manufacturer (O.E.M.) replacement parts.
 Failure to do so could be hazardous, damage your snow thrower and void your warranty.

REPAIR PARTS

CONTROL PANEL / DISCHARGE CHUTE

SNOW THROWER - MODEL NO. **DST24** (96192010600), PRODUCT NO. 961 92 01-06

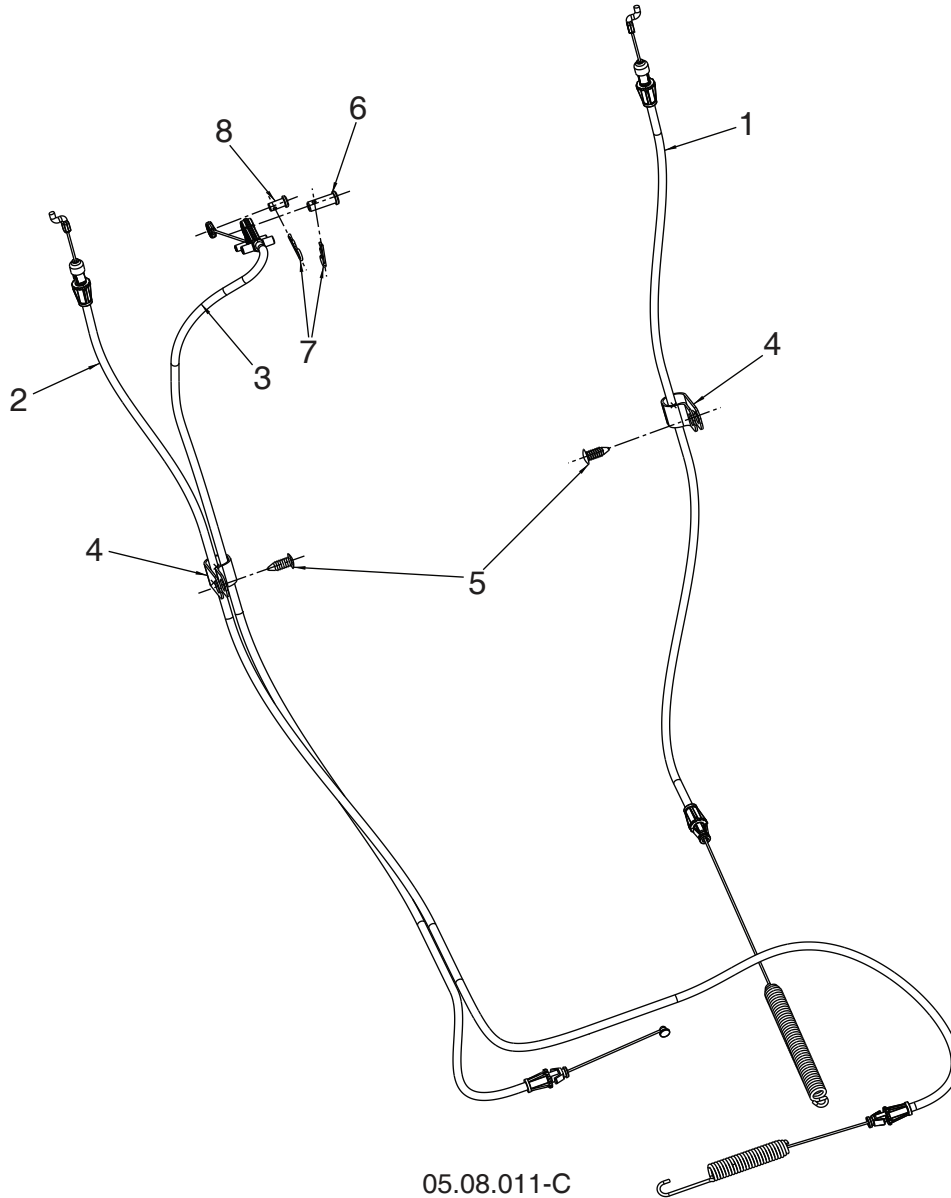

KEY NO.	PART NO.	DESCRIPTION
1	582 51 90-01	CABLE CONTROL DRIVE
2	588 11 38-01	CABLE CONTROL AUGER
3	588 12 23-01	CABLE CONTROL SPEED
4	532 19 79-91	CLIP CABLE
5	532 42 81-24	FASTENER PUSH .250
6	581 32 94-01	PIN CLEVIS 5/16
7	532 42 33-03	HAIRPIN
8	585 80 83-01	PIN CLEVIS 1/4

NOTE: All component dimensions given in U.S. inches. 1 inch = 25.4 mm
IMPORTANT: Use only Original Equipment Manufacturer (O.E.M.) replacement parts. Failure to do so could be hazardous, damage your snow thrower and void your warranty.

REPAIR PARTS

CONTROL PANEL / DISCHARGE CHUTE

SNOW THROWER - MODEL NO. DST24 (96192010600), PRODUCT NO. 961 92 01-06

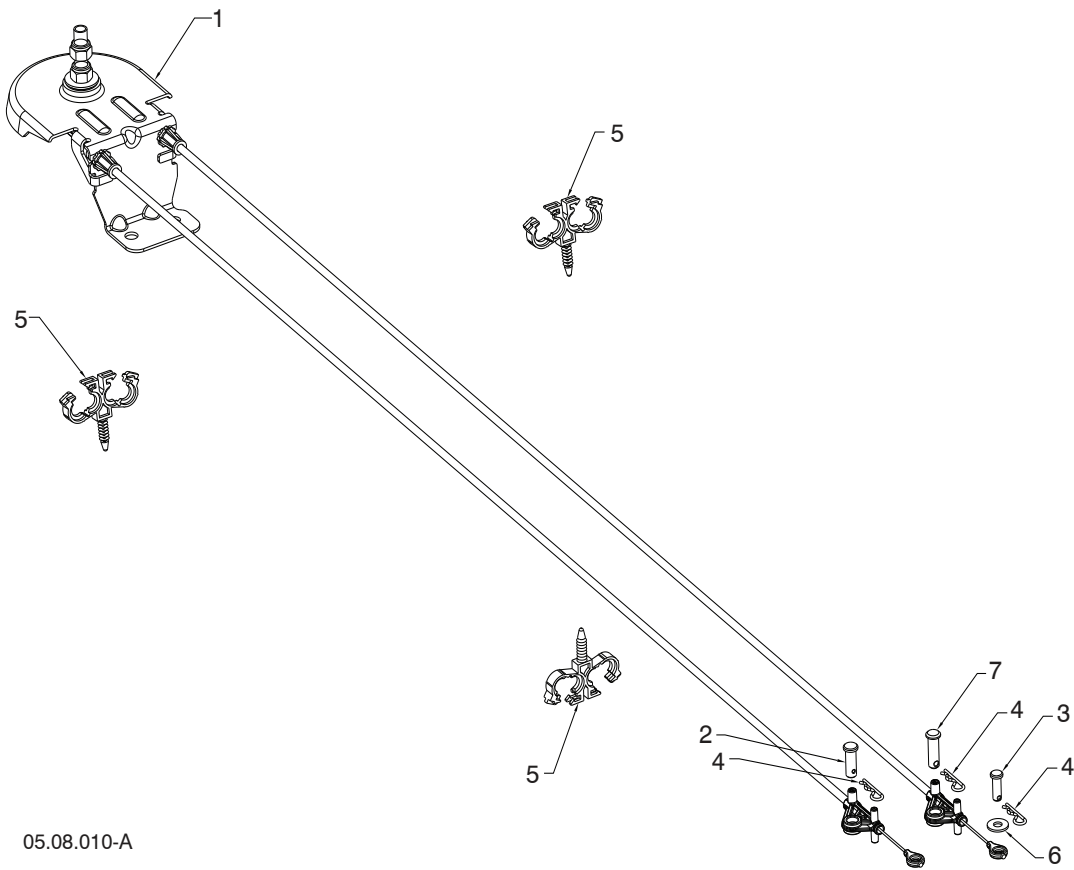

05.08.010-A

KEY NO.	PART NO.	DESCRIPTION
1	587 80 34-01	CABLE CHUTE ROTATOR ASM
2	581 32 94-01	PIN CLEVIS 5/6 X 7/8
3	877 10 08-12	PIN CLEVIS 1/4 X 3/4
4	532 42 33-03	HAIRPIN SOFT ZINC
5	584 65 22-01	CLIP CONDUIT DOUBLE
6	586 68 21-01	WASHER
7	587 13 08-01	PIN CLEVIS 5/16 X 1

NOTE: All component dimensions given in U.S. inches. 1 inch = 25.4 mm
IMPORTANT: Use only Original Equipment Manufacturer (O.E.M.) replacement parts. Failure to do so could be hazardous, damage your snow thrower and void your warranty.

REPAIR PARTS

HANDLES

SNOW THROWER - MODEL NO. DST24 (96192010600), PRODUCT NO. 961 92 01-06

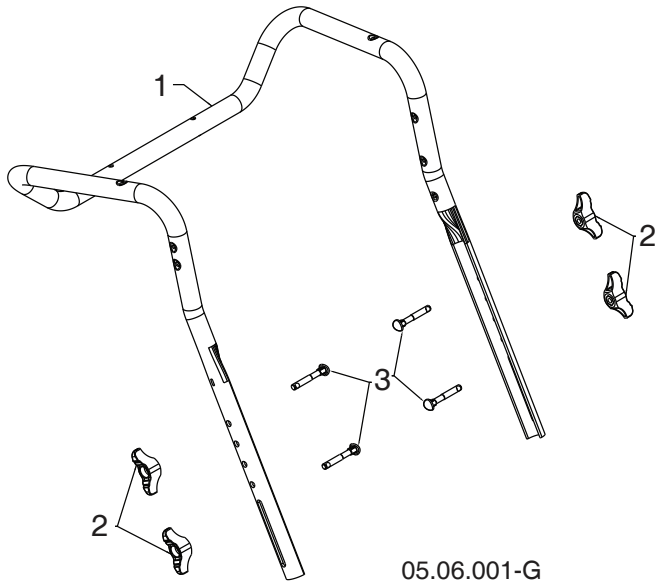

KEY NO.	PART NO.	DESCRIPTION
1	588 16 08-02	UPPER HANDLE
2	532 19 19-38	HANDLE KNOB STD BLACK
3	588 05 99-01	SCREW 5/16-18 X 2.25 CON CAVE HEAD WITH PATCH

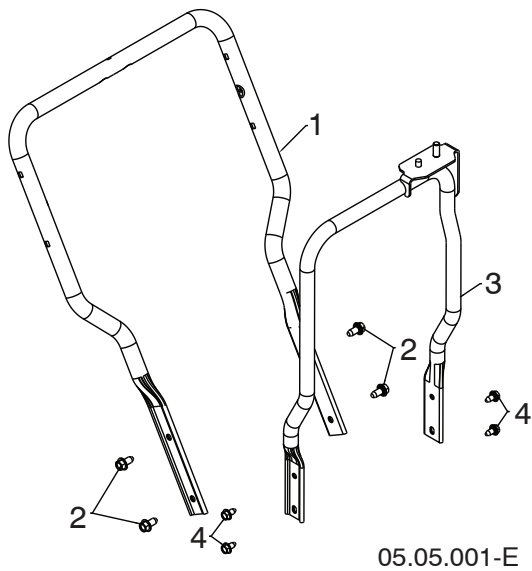

KEY NO.	PART NO.	DESCRIPTION
1	588 67 21-02	LOWER HANDLE
2	817 00 06-12	SCREW HEX WASH HD 3/8-16 X .75
3	589 26 45-04	CHUTE ROTATOR SUPPORT ASM
4	817 00 05-10	BOLT HEX 5/16-18

NOTE: All component dimensions given in U.S. inches. 1 inch = 25.4 mm
IMPORTANT: Use only Original Equipment Manufacturer (O.E.M.) replacement parts. Failure to do so could be hazardous, damage your snow thrower and void your warranty.

REPAIR PARTS

DRIVE

SNOW THROWER - MODEL NO. DST24 (96192010600), PRODUCT NO. 961 92 01-06

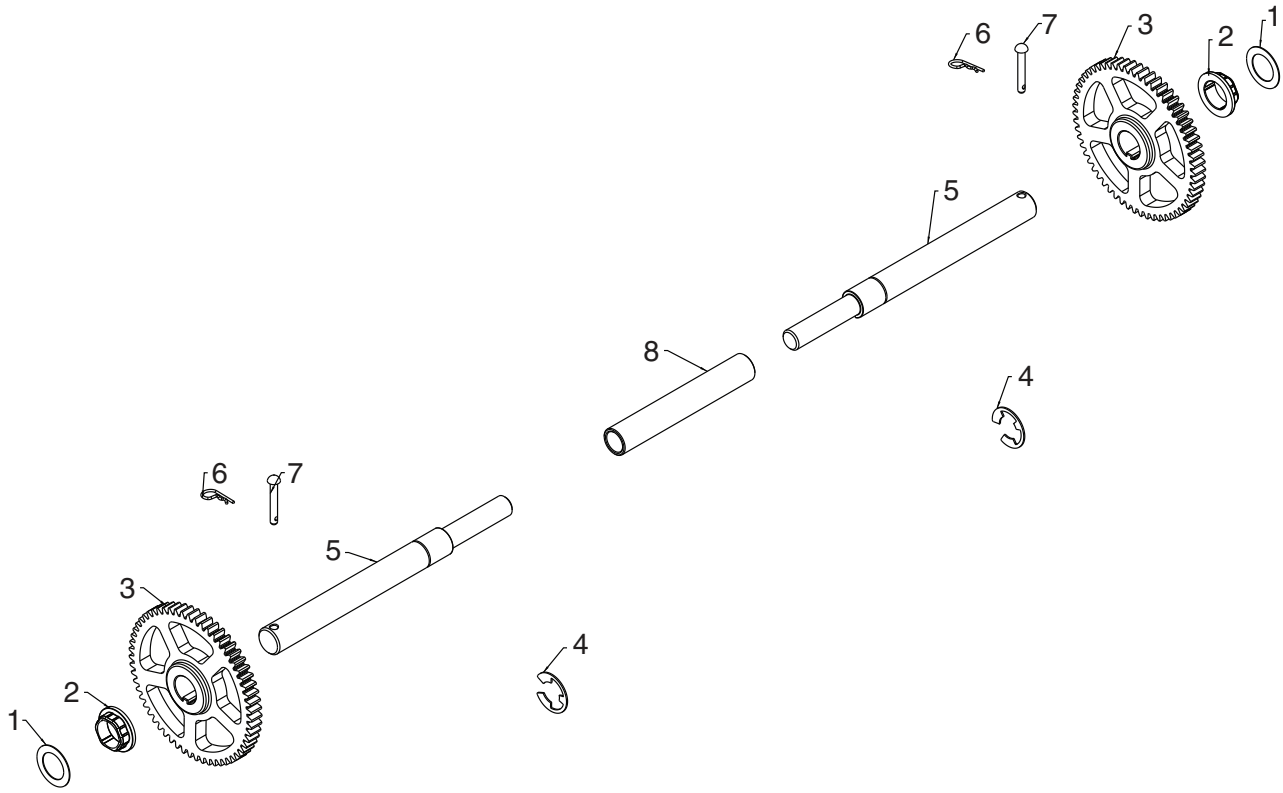

05.03.002-B

KEY NO.	PART NO.	DESCRIPTION
1	532 44 49-49	WASHER 1.00
2	587 97 89-01	BUSHING HEX 1 SHAFT
3	588 51 86-01	GEAR 59T DRIVEN
4	812 00 00-53	RETAINING RING
5	580 75 26-01	AXLE SHAFT SPLIT
6	532 12 47-88	RETAINER SPRING 1 ZINC
7	532 17 12-71	RIVET RD HD DRILLED 1/4 DIA
8	580 75 25-01	AXLE SLEEVE

NOTE: All component dimensions given in U.S. inches. 1 inch = 25.4 mm
IMPORTANT: Use only Original Equipment Manufacturer (O.E.M.) replacement parts. Failure to do so could be hazardous, damage your snow thrower and void your warranty.

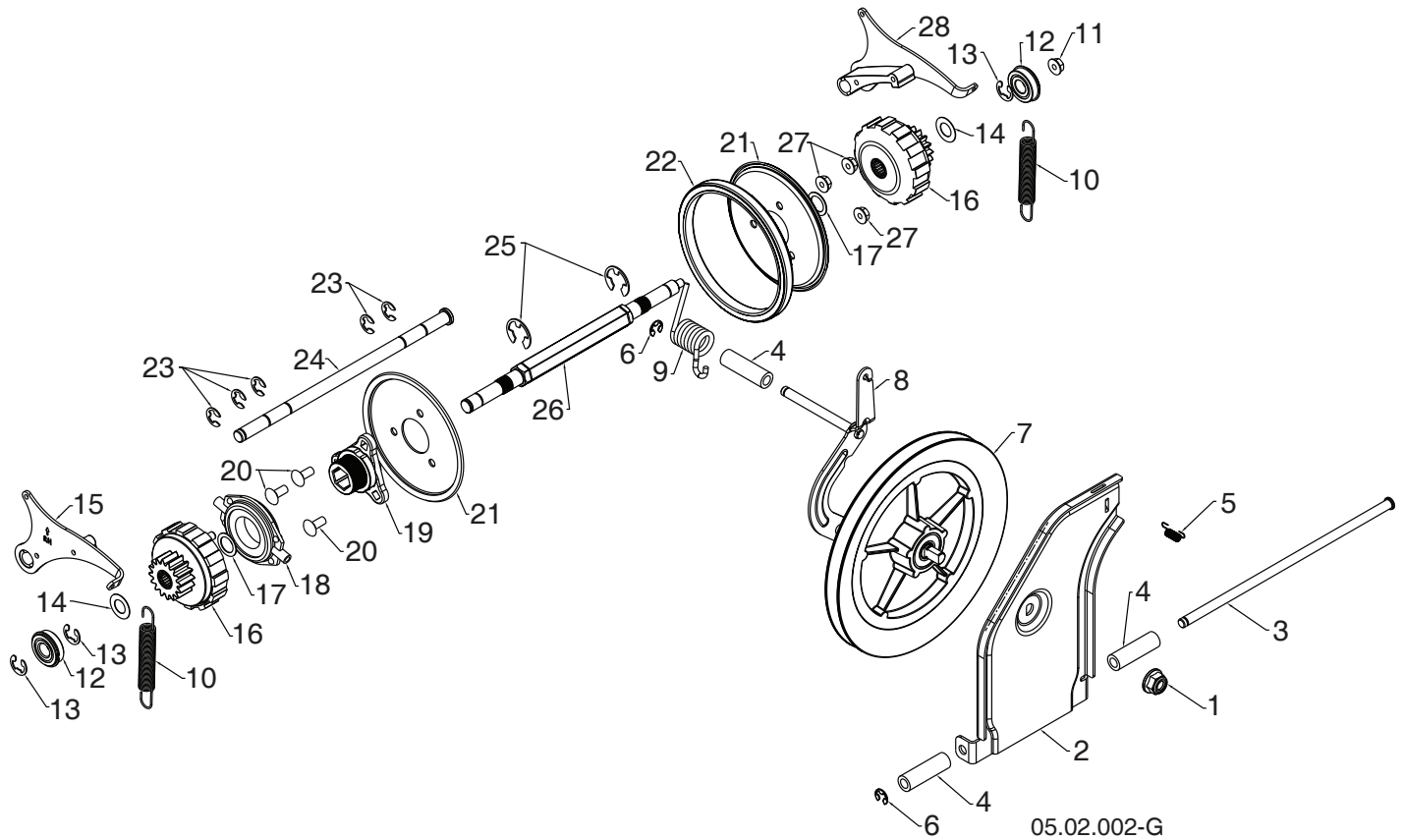

NOTE: All component dimensions given in U.S. inches. 1 inch = 25.4 mm
IMPORTANT: Use only Original Equipment Manufacturer (O.E.M.) replacement parts.
 Failure to do so could be hazardous, damage your snow thrower and void your warranty.

SNOW THROWER - MODEL NO. **DST24** (96192010600), PRODUCT NO. 961 92 01-06

KEY NO.	PART NO.	DESCRIPTION
1	521 99 11-01	NUT HEX FLANGE LK 1/2-13
2	587 70 34-02	SWING PLATE FRICTION PULL
3	581 12 30-01	ROD TIP PLATE
4	581 73 27-01	SPACER DRIVE
5	532 19 38-85	LATCH SPRING
6	812 00 00-07	E-RING RETAINER
7	581 32 84-01	FRICTION DISC COMBO PULLEY
8	587 19 34-03	BRACKET YOKE ASSEMBLY
9	581 31 53-01	SPRING TORSION DRIVE
10	585 26 38-01	EXTENSION SPRING
11	585 69 15-01	NUT HEX FLANGE LOCK 5/16-18
12	580 75 62-01	BEARING 9/16 I.D. 1622-2RSNR
13	580 75 61-02	RETAINING RING 1622-2RSNR
14	580 75 13-01	WASHER FLAT .59 I.D. X 1.065 X 25 GA
15	580 75 66-01	PAWL ASM RH
16	580 75 60-01	GEAR ASM PLANETARY
17	580 75 63-01	WASHER FLAT .6875 I.D. X 1.00 X 21 GA
18	532 17 53-44	TRUNNION BEARING ASM
19	581 09 09-01	HUB RUBBER WHEEL
20	872 11 05-06	BOLT CARRIAGE 5/16-18 X .75
21	581 09 10-02	PLATE RUBBER WHEEL
22	581 09 11-01	RING RUBBER WHEEL
23	586 64 43-01	E-RING
24	580 75 51-01	ROD PAWL
25	812 00 00-22	E-RING
26	580 75 24-01	SHAFT REDUCTION PWR STR
27	532 75 11-53	NUT HEX FLANGE LK 5/16-18
28	580 75 67-01	PAWL ASM LH

NOTE: All component dimensions given in U.S. inches. 1 inch = 25.4 mm
IMPORTANT: Use only Original Equipment Manufacturer (O.E.M.) replacement parts.
 Failure to do so could be hazardous, damage your snow thrower and void your warranty.

REPAIR PARTS

CHASSIS / ENGINE / PULLEYS

SNOW THROWER - MODEL NO. DST24 (96192010600), PRODUCT NO. 961 92 01-06

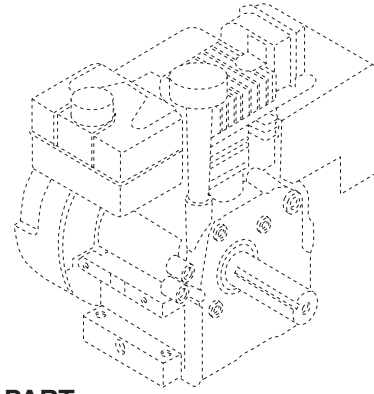
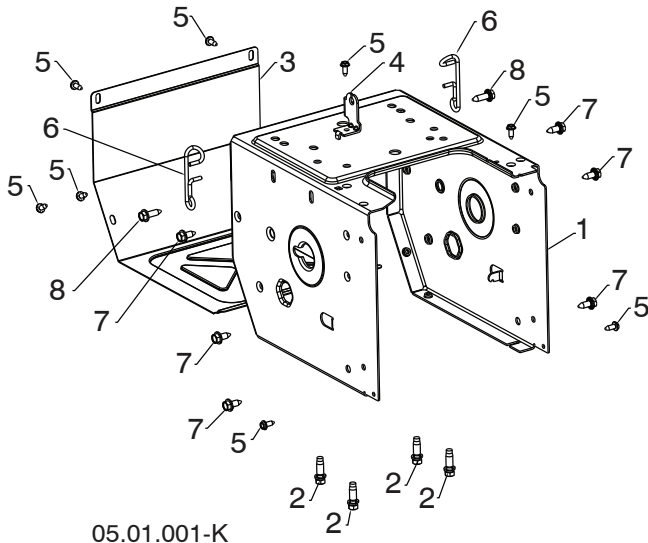

KEY NO.	PART NO.	DESCRIPTION
--	590 21 86-03	COMPLETE LCT ENGINE PW2HK18650178E
1	589 26 47-13	FRAME
2	532 15 0406	ENGINE BOLT 3/8-16 X 1.280 DOGPOINT
3	580 83 95-13	FRAME COVER
4	501 06 04-03	SHIFTER BRACKET
5	582 90 69-01	SCREW HEX WASHER 1/4-20 X .625
6	588 95 45-01	WIREFORM SUPPORT CABLE
7	532 42 88-67	BOLT HEXHD WASHER 5/16-18 X .750
8	585 21 75-01	BOLT HEXHD WASHER 5/16-18 X 1.000

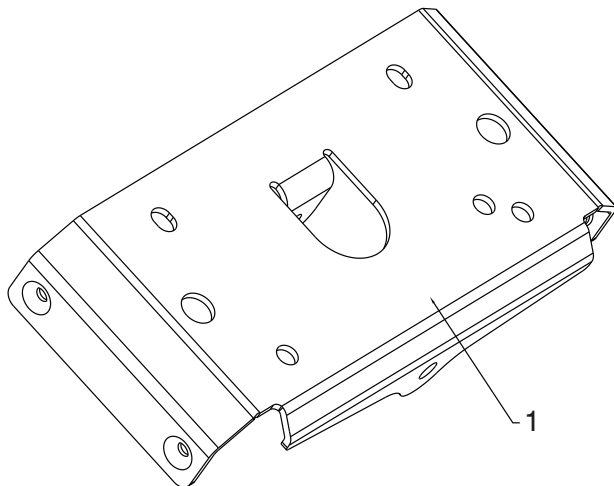

KEY NO.	PART NO.	DESCRIPTION
1	583 94 05-02	SMALL MOUNTING PLATE

NOTE: All component dimensions given in U.S. inches. 1 inch = 25.4 mm

IMPORTANT: Use only Original Equipment Manufacturer (O.E.M.) replacement parts. Failure to do so could be hazardous, damage your snow thrower and void your warranty.

REPAIR PARTS

CHASSIS / ENGINE / PULLEYS

SNOW THROWER - MODEL NO. DST24 (96192010600), PRODUCT NO. 961 92 01-06

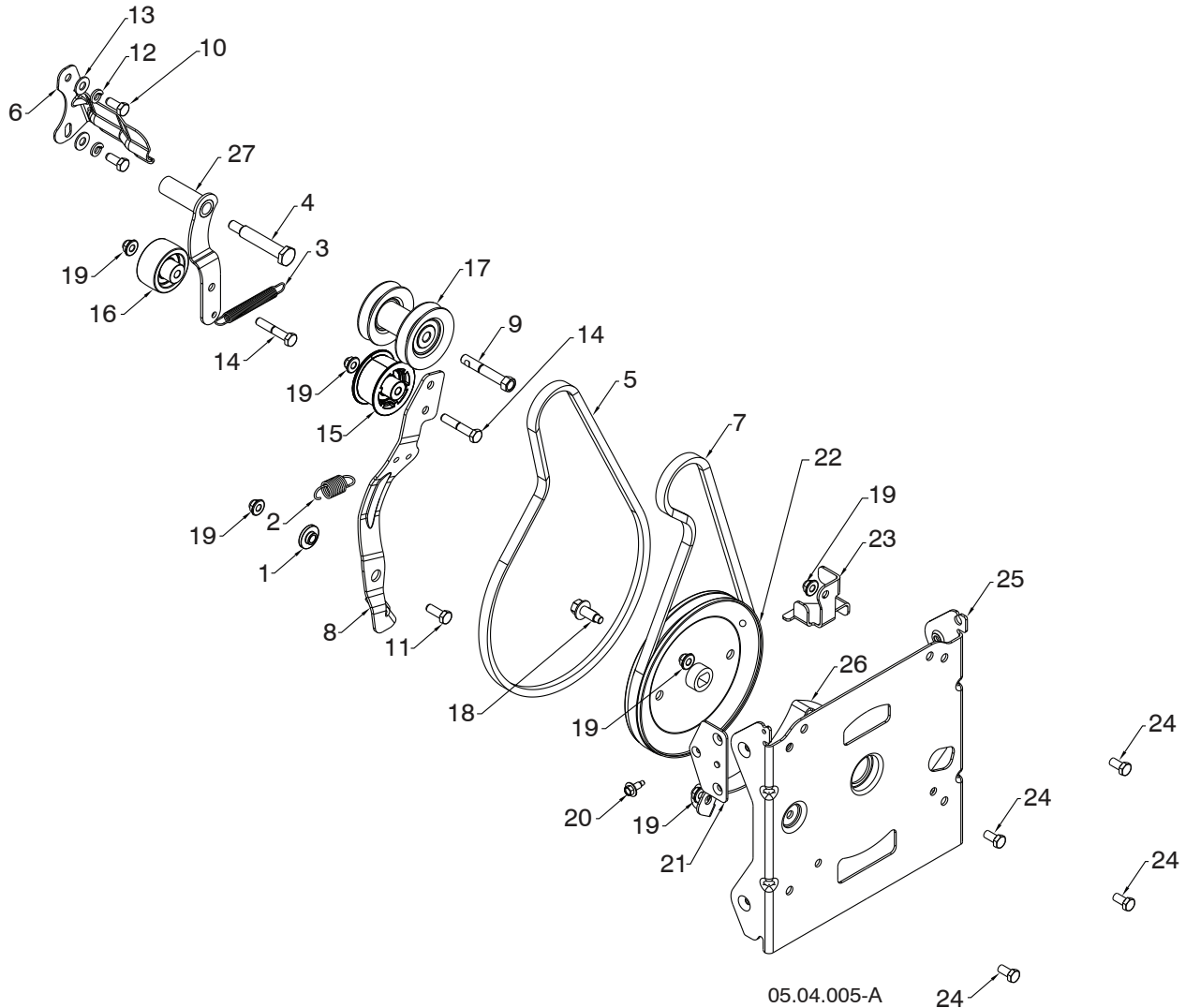

KEY NO.	PART NO.	DESCRIPTION	KEY NO.	PART NO.	DESCRIPTION
1	587 34 37-01	BUSHING BRAKE ARM	16	586 88 02-01	PULLEY IDLER 2.0 O/ SPACER
2	587 03 12-01	SPRING RETURN IDLER ARM	17	587 89 37-03	PULLEY ASM IMPELLER/DRIVE
3	580 75 30-01	SPRING RETURN IDLER ARM	18	583 81 49-01	SCREW FLANGE HEAD 3/8-16
4	581 41 38-01	BOLT SHOULDER 5/16-24 X 2.15	19	532 42 79-42	NUT NYLOK FLANGE 5/16-18
5	584 21 61-02	BELT DRIVE 4L X 38.19	20	585 51 78-01	SCREW 1/4-20 X .65 W/DOG POINT
6	588 49 28-02	BRACKET BELT KEEPER 007	21	590 04 46-02	BRACKET NUT BZP
7	501 81 82-01	BELT IMPELLER LOW CRANK	22	590 69 92-01	PULLEY IMPELLER DD 4L
8	580 83 11-06	ARM IDLER AUTO PH .676	23	587 58 72-02	GUIDE LOWER AUGER BELT 479
9	582 38 84-01	BOLT ENGINE PULLEY	24	532 16 31-83	BOLT HXHD 5/16-18 X 5/8
10	874 61 05-12	CAPSCREW HEXHD 5/16-24 X .75 GR5	25	581 59 25-02	BRACKET AUG HOUSING INTER 479
11	874 76 05-14	BOLT HEXHD 5/16-18 X .875	26	581 63 20-02	BRACKET BELT KEEPER LOWER 479
12	810 04 05-00	LOCKWASHER 5/16 SPLIT HVY	27	581 33 82-03	ARM IDLER DRIVE
13	819 11 12-16	WASHER 11/32 X 3/4 X 16GA			
14	874 76 05-28	BOLT HXHD 5/16-18 X 1.75			
15	581 14 14-01	PULLEY IDLER 2.0 WITH SPACER			

NOTE: All component dimensions given in U.S. inches. 1 inch = 25.4 mm

IMPORTANT: Use only Original Equipment Manufacturer (O.E.M.) replacement parts. Failure to do so could be hazardous, damage your snow thrower and void your warranty.

REPAIR PARTS

CHASSIS / ENGINE / PULLEYS

SNOW THROWER - MODEL NO. DST24 (96192010600), PRODUCT NO. 961 92 01-06

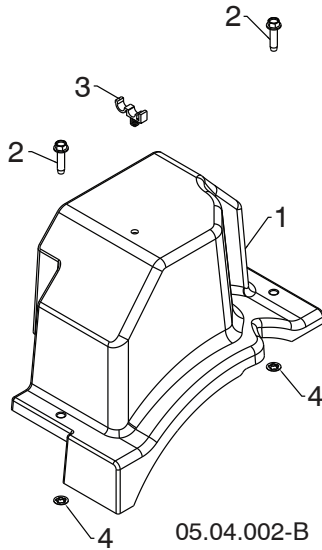

KEY NO.	PART NO.	DESCRIPTION
1	587 10 54-01	BELT COVER BLACK ASSEMBLY (INCLUDES 2 & 4)
2	-----	BOLT HEX WSH THDRL 1/4-20 X 1
3	532 14 50-06	CABLE GUIDE
4	-----	PALNUT 1/4 IN

NOTE: All component dimensions given in U.S. inches. 1 inch = 25.4 mm
IMPORTANT: Use only Original Equipment Manufacturer (O.E.M.) replacement parts. Failure to do so could be hazardous, damage your snow thrower and void your warranty.

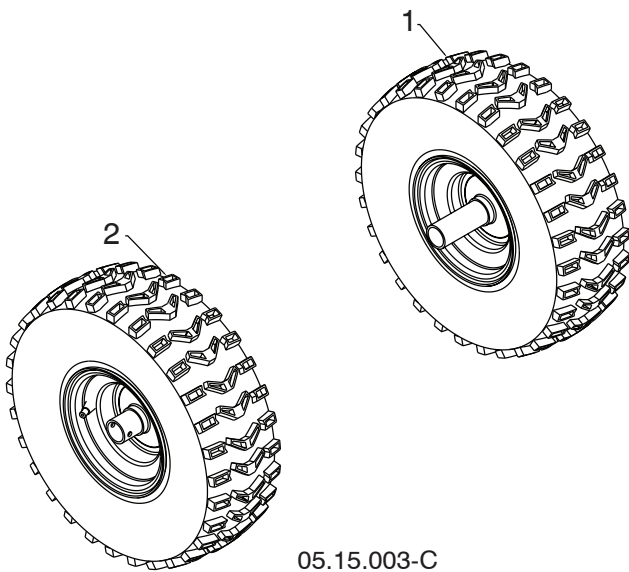

KEY NO.	PART NO.	DESCRIPTION
1	586 71 04-01	WHEEL 15 X 5.00 NPS LH 1.00
2	586 71 03-01	WHEEL 15 X 5.00 NPS RH 1.00

NOTE: All component dimensions given in U.S. inches. 1 inch = 25.4 mm
IMPORTANT: Use only Original Equipment Manufacturer (O.E.M.) replacement parts.
Failure to do so could be hazardous, damage your snow thrower and void your warranty.

REPAIR PARTS

BAG OF PARTS

SNOW THROWER - MODEL NO. DST24 (96192010600), PRODUCT NO. 961 92 01-06

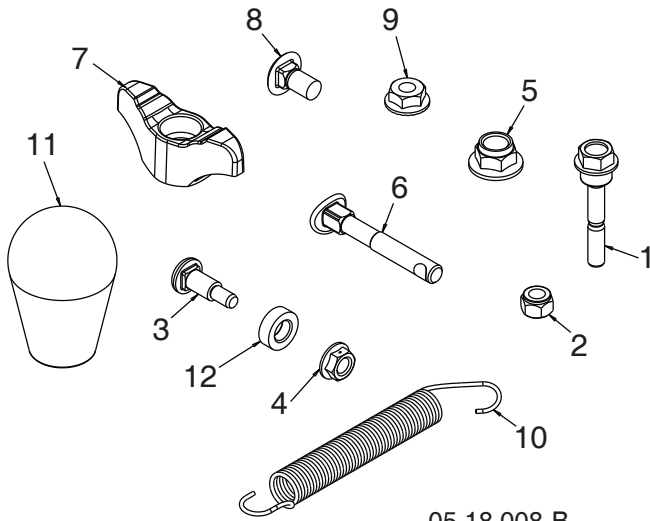

KEY NO.	PART NO.	DESCRIPTION
1	588 07 75-01	BOLT 1/4-20 X 1.81
2	873 80 04-00	NUT NYLOCK 1/4-20
3	501 41 73-01	BOLT SHOULDER
4	585 69 14-01	NUT HEX FL 1/4-20 CTR
5	588 25 29-01	NUT NYLOCK 3/8-16
6	588 05 99-01	BOLT 5/16-18 X 2.25 CONCAVE
7	532 19 19-38	KNOB 5/16-18 X .625
8	585 83 20-01	BOLT 5/16-18 X .625
9	873 97 05-00	NUT SERR FL LOCK 5/16-18
10	532 18 45-05	SPRING DEFLECT CHUTE
11	581 69 75-01	KNOB SOFT TOUCH SLOTTED
12	501 41 74-01	WASHER NYLON
NI	588 07 76-06	KIT REPLACEMETN BAG OF PARTS

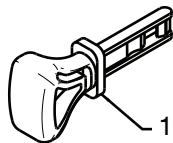

01.14.009-B

KEY NO.	PART NO.	DESCRIPTION
1	532 44 30-59	SAFETY IGNITION KEY KIT

NOTE: All component dimensions given in U.S. inches. 1 inch = 25.4 mm
IMPORTANT: Use only Original Equipment Manufacturer (O.E.M.) replacement parts. Failure to do so could be hazardous, damage your snow thrower and void your warranty.

SNOW THROWER - MODEL NO. DST24 (96192010600), PRODUCT NO. 961 92 01-06



1



4



3



2

05.16.001-A

KEY NO.	PART NO.	DESCRIPTION
1	532 18 40-45	DECAL AUGER
2	590 81 22-01	DECAL CHUTE
3	532 19 96-83	DECAL AUGER SAFETY
4	532 18 40-28	DECAL BELT GUIDE

NOTE: All component dimensions given in U.S. inches. 1 inch = 25.4 mm
IMPORTANT: Use only Original Equipment Manufacturer (O.E.M.) replacement parts. Failure to do so could be hazardous, damage your snow thrower and void your warranty.

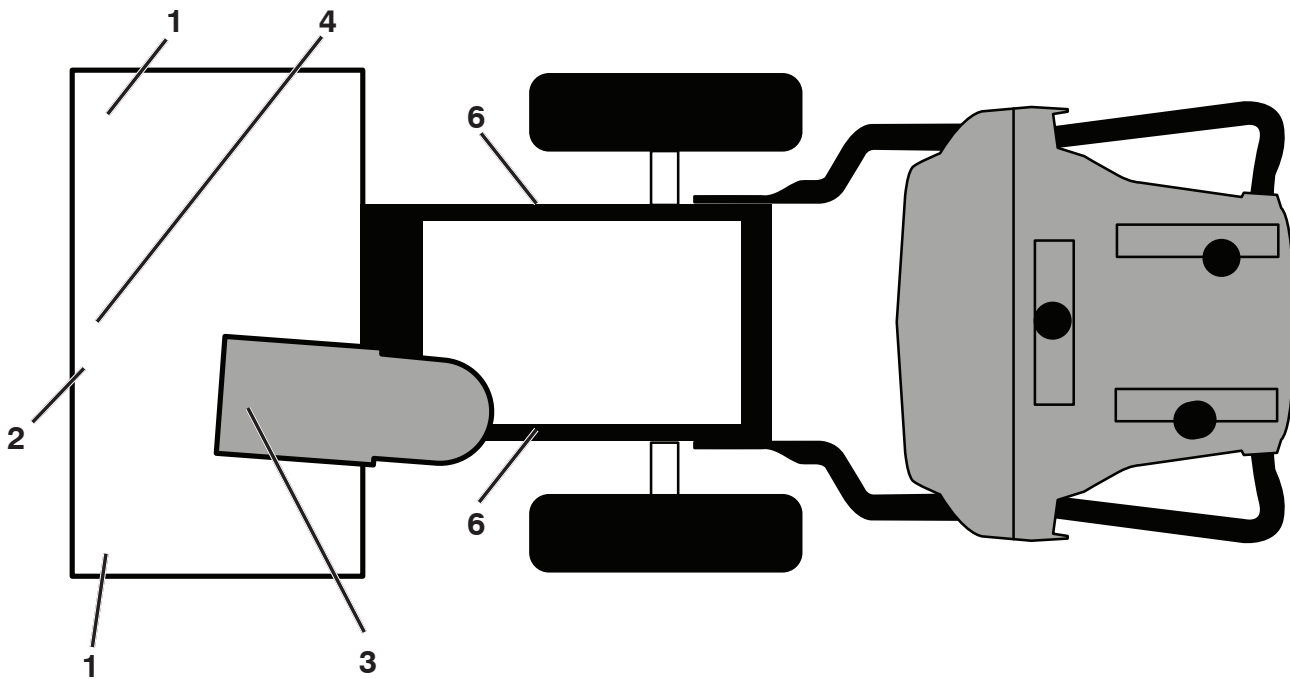

KEY PART NO.	PART NO.	DESCRIPTION
1	532 19 96-83	DECAL, AUGER
2	595 32 80-01	DECAL, AUGER HOUSING
3	590 81 22-01	DECAL, DANGER, DEFLECTOR
4	532 18 40-45	DECAL, DANGER
6	532 18 40-28	DECAL, BELT GUARD
--	532 17 45-72	DECAL
--	595 32 78-01	DECAL, ENGINE
--	114 04 15-49	OPERATOR'S MANUAL

NOTE: All component dimensions given in U.S. inches. 1 inch = 25.4 mm
IMPORTANT: Use only Original Equipment Manufacturer (O.E.M.) replacement parts. Failure to do so could be hazardous, damage your snow thrower and void your warranty.

ENGINE, LCT

COMPLETE ENGINE-590218603

GEN II 136/179/208/254cc Snow Engines

9999 Options

DECALS ← 72

Carburetor
Repair Kit ← 70

← 77

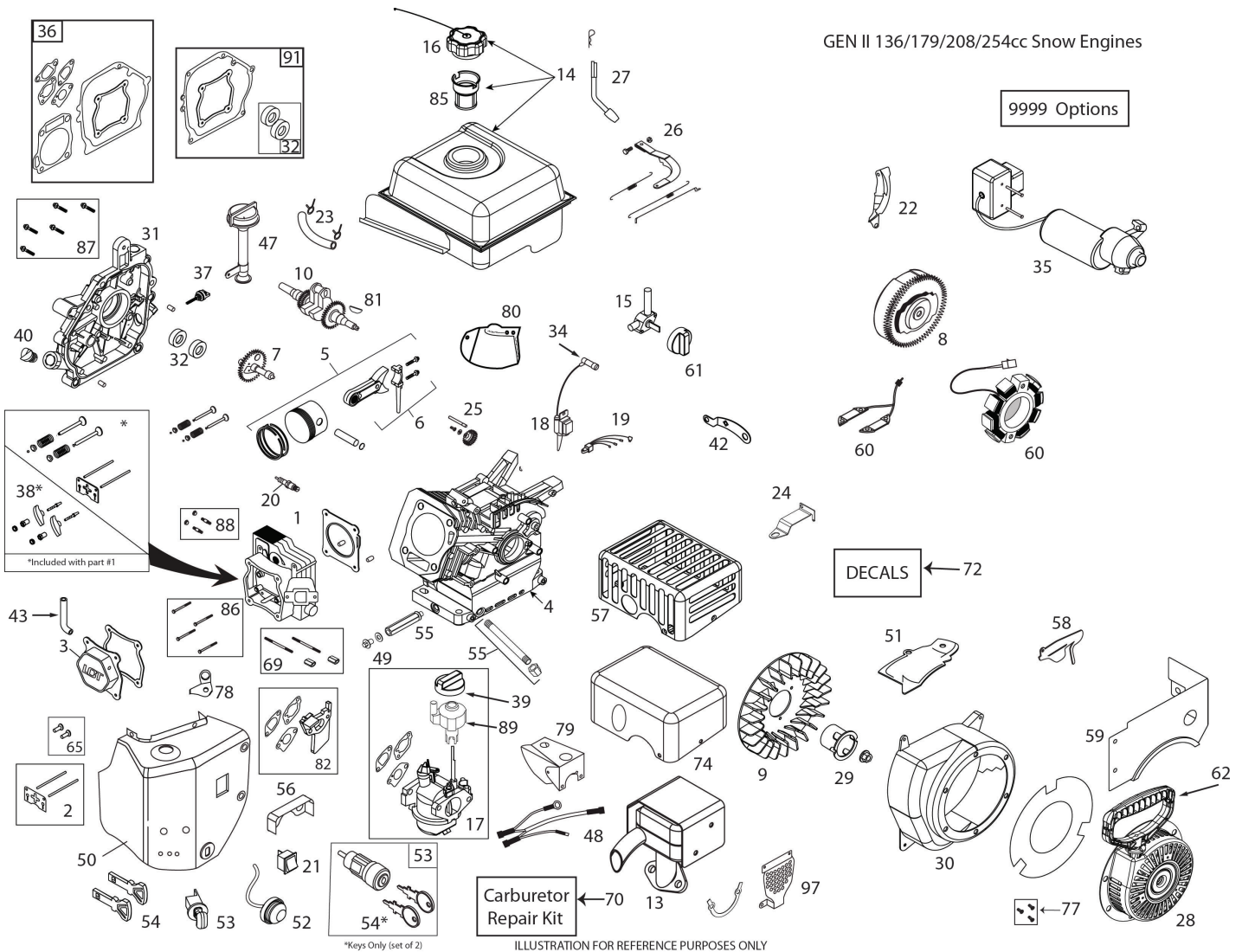

*Included with part #1

*Keys Only (set of 2)

ILLUSTRATION FOR REFERENCE PURPOSES ONLY

KEY NO.	PART NO.	DESCRIPTION	KEY NO.	PART NO.	DESCRIPTION
1	532 42 05-78	CYLINDER HEAD ASSEMBLY (INCL. GASKET)	17	587 14 79-01	CARBURETOR (W/IDLE SPEED CONTROL - W/GSKTS)
2	532 42 05-79	PUSH ROD & PLATE KIT (W/ VALVE COVER GSKT)	18	532 44 39-34	IGNITION COIL (CDI)
3	532 42 05-80	VALVE COVER (INCL. GASKET)	19	N/A	N/A
4	N/A	N/A	20	532 42 49-39	SPARK PLUG
5	532 42 05-82	PISTON & ROD ASSEMBLY	21	N/A	N/A
6	N/A	N/A	22	585 77 24-01	SHIELD - FLYWHEEL
7	532 42 05-84	CAMSHAFT - MCR	23	532 43 21-44	FUEL HOSE KIT
8	595 01 24-01	FLYWHEEL - ELECTRIC START W/ 6 MAGNETS	24	532 42 92-59	SPEED CONTROL BRACKET (FIXED)
9	532 42 05-86	COOLING FAN - FLYWHEEL	25	532 42 96-46	GOVERNOR GEAR ASSEMBLY
10	532 44 66-42	CRANKSHAFT	26	581 76 87-01	GOVERNOR ARM & LINK KIT
13	587 73 78-01	MUFFLER ASSEMBLY	27	532 42 06-02	GOVERNOR ARM PADDLE
14	532 43 65-64	FUEL TANK (2.7L BLACK W/ PLASTIC CAP)	28	532 43 69-67	RECOIL STARTER ASSY (ROUND-BLACK)
15	532 42 92-34	FUEL TANK ON/OFF VALVE (PETCOCK)	29	532 43 69-68	STARTER CUP (USE WITH ROUND STYLE STARTER)
16	532 42 49-42	FUEL TANKCAP - BLACKCLICK STYLE (VENTED)	30	581 19 20-01	BLOWER HOUSING - BLACK ELECTRIC START

ENGINE, LCT**COMPLETE ENGINE-590218603**

KEY NO.	PART NO.	DESCRIPTION	KEY NO.	PART NO.	DESCRIPTION
31	581 00 73-01	CRANKCASE COVER ASSY (PRESS-IN TYPE HOFT) (INCL. GASKET)	59	532 43 65-62	FUEL TANK SKIRT
32	532 42 95-99	OIL SEAL KIT (2 PCS)	60	532 44 38-93	60 WATT AC CHARGING COIL
34	532 43 69-66	SPARK PLUG BOOT	61	532 43 27-52	FUEL CONTROL KNOB (RED)
35	532 43 64-66	120V ELECTRIC STARTER (SIDE MOUNT)	62	N/A	N/A
36	532 42 96-01	ENGINE GASKET KIT	65	581 37 28-01	TAPPET KIT (SET OF 2)
37	532 42 09-61	SMALL BLACK OIL DIPSTICK (PLASTIC)	69	532 42 49-51	CARBURETOR STUDS & COUPLING KIT-SNOW
38	532 42 96-91	ROCKERARMKIT (INCL. GASKET)	70	580 35 36-02	CARBURETOR REPAIR KIT
39	532 42 92-24	CHOKE CONTROL KNOB (GEN II RED)	72	N/A	N/A
40	532 42 95-98	NON-REMOVABLE PLASTIC PLUG	74	587 82 11-01	MUFFLER HEAT SHIELD COVER
42	N/A	N/A	77	532 43 26-88	RECOIL BOLT KIT (3 BOLTS PER KIT)
43	580 35 34-01	BREATHER TUBE	78	581 45 93-01	BREATHER TUBE BRACKET
47	581 00 72-01	HIGH OIL-FILL TUBE/DIPSTICK (PRESS-IN TYPE)	79	N/A	SEE REF 58 N/A PART OF REF 58, ALL ONE PART
48	595 01 25-01	WIRE HARNESS (W/O ON/OFF SWITCH)	80	N/A	SEE REF 58 N/A PART OF REF 58, ALL ONE PART
49	532 43 54-95	OIL DRAIN PLUG W/WASHER	81	585 29 72-01	WOODRUFF FLYWHEEL KEYS (5-PACK)
50	595 01 26-01	HEATER BOX (W/O ON/OFF SWITCH)	82	585 02 05-03	CARBURETOR SPACER KIT
51	532 43 71-19	SHIELD - CYLINDER	85	586 32 56-01	FUEL TANK STRAINER
52	532 42 49-49	PRIMER BULB WITH HOSE	86	586 32 73-02	CYLINDER HEAD BOLT KIT (4)
53	532 42 49-54	SAFETY KEY SWITCH -SNOW (INCL. KEYS)	87	586 32 69-01	CC COVER BOLT KIT (6)
54	532 44 30-59	KEY SET - RED (2) (SNOW)	88	586 32 68-01	MUFFLER MTG STUD KIT (2)
55	532 43 26-86	OIL DRAIN TUBE-SNOW	89	N/A	N/A
56	N/A	SEE REF 58 N/A PART OF REF 58, ALL ONE PIECE	91	587 52 57-01	CRANKSHAFT GASKET KIT
57	N/A	N/A	97	589 75 26-01	MUFFLER MANIFOLD SHIELD
58	595 01 27-01	GOV AND CARB SHIELD - COMPOSITE (ALSO REPLS 56, 79, 80)	9999	586 32 62-01	HIGH ALTITUDE JET (>6,000 FEET)
			9999	579 80 64-01	BOLT KIT - BLOWER HSG-HEATER BOX-TANK SKIRT
			9999	590 92 08-01	STARTER SWITCH BOX SCREWS