

ILLUSTRATED PARTS LIST

MFG. ID NO. 96041037200

CUSTOMER CATALOG NO. TS 346

PRODUCT NO. 960 41 03-72

47

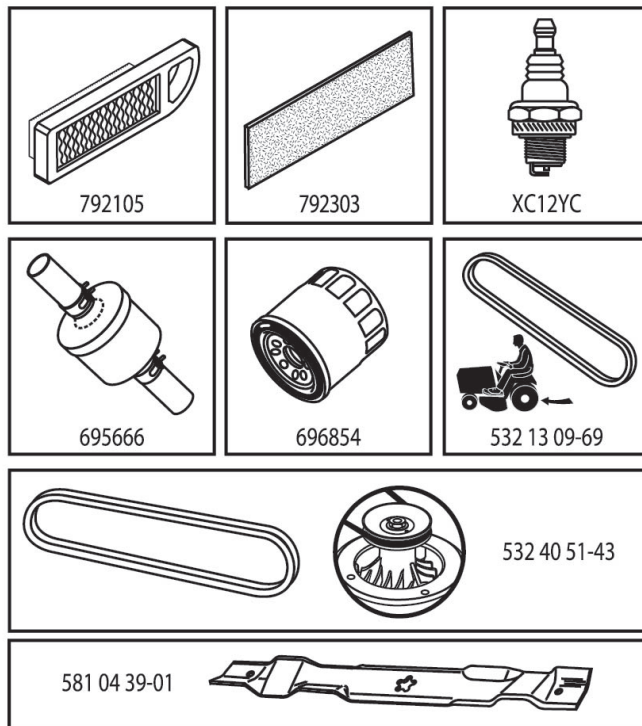

587531601

**TRACTOR - - MODEL NO. TS 346 (96041037200), PRODUCT NO. 960 41 03-72
DECALS 27**

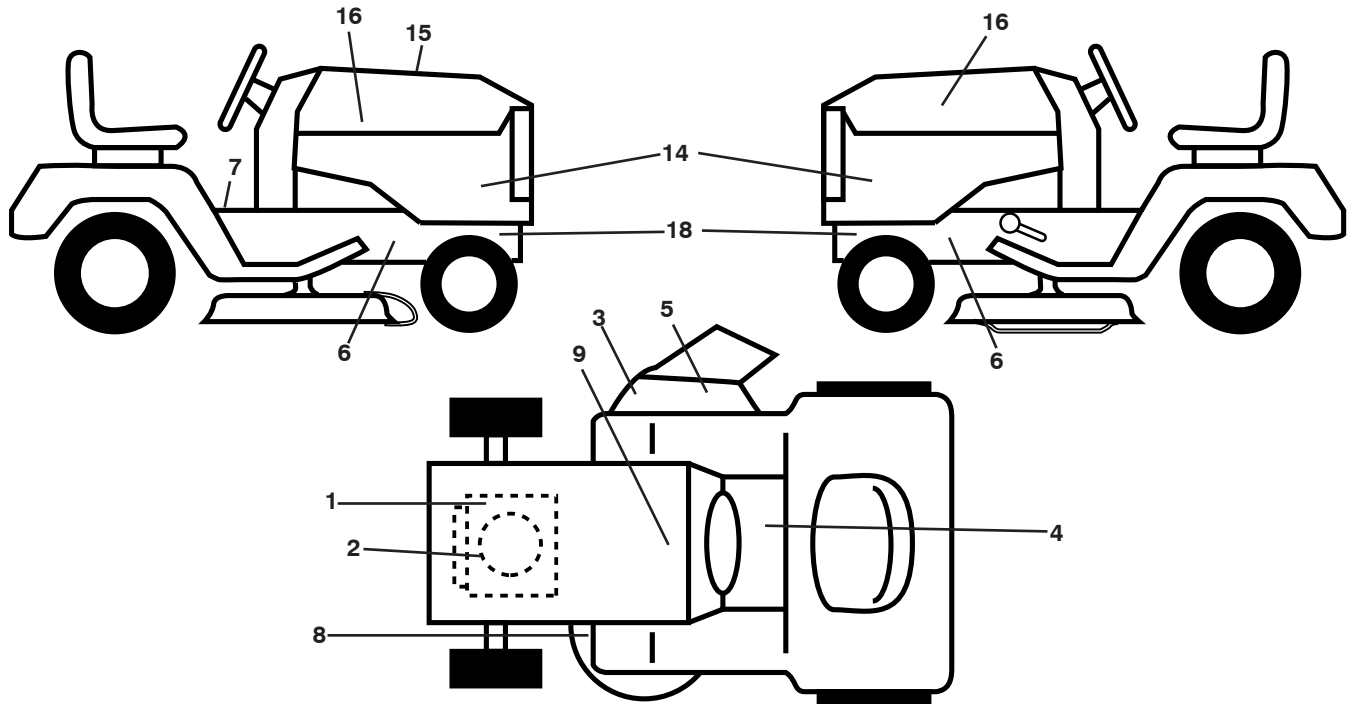

KEY NO.	PART NO.	DESCRIPTION
1	581 57 97-01	Decal, Engine Warning
2	587 46 92-01	Decal, Engine
3	581 57 92-01	Decal, Warning
4	586 80 03-01	Decal, Tractor Saddle
5	584 90 46-01	Decal, Deflect. Warning
6	581 57 98-01	Decal, Warning
7	586 34 95-01	Decal, Warning Symbols
8	581 58 00-01	Decal, Mower Sch.
9	532 14 50-05	Decal, Battery Dan./Poi.
14	587 39 72-01	Decal, Panel Side
15	587 53 16-01	Decal, Replacement Parts

KEY NO.	PART NO.	DESCRIPTION
16	581 62 73-01	Decal, Hood Logo
18	581 57 96-01	Decal, Chassis Hot Muffler
--	581 72 46-01	Decal, Drawbar Load Limit
--	581 72 48-01	Decal, Bypass
--	532 43 98-82	Pad, Footrest, LH
--	532 43 98-81	Pad, Footrest, RH
--	588 78 48-20	Manual, Operator's (Euro)
--	588 78 48-10	Manual, Operator's (Scan)
--	588 78 48-50	Manual, Operator's (E-bloc)
--	588 78 48-40	Manual, Operator's (Baltic)

WHEELS AND TIRES

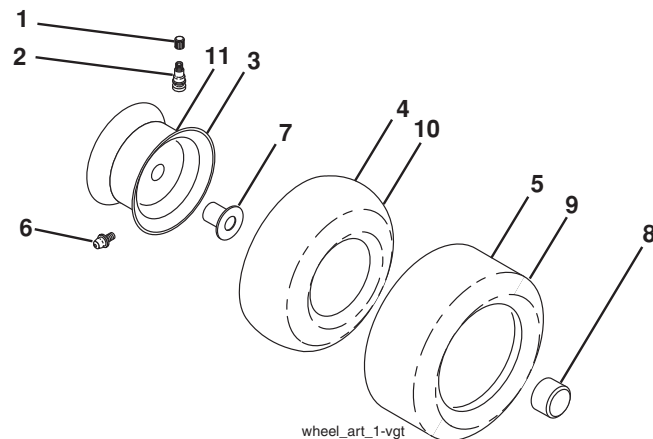

KEY NO.	PART NO.	DESCRIPTION
1	532 05 91-92	Cap, Valve, Tire
2	532 06 51-39	Stem, Valve
3	532 13 83-36	Rim Assembly, Front
4	532 05 99-04	Tube, Front (Service Item Only)
5	532 10 62-22	Tire, Front 15 x 6-6
6	532 12 49-57	Fitting, Grease (Front Wheel Only)
7	532 12 49-59	Bearing, Flange (Front Wheel Only)
8	532 17 50-39	Cap, Axle (Front Wheel Only)
9	532 12 20-82	Tire, Rear 20 x 10-8
10	532 12 49-26	Tube, Rear (Service Item Only)
11	532 13 83-37	Rim Assembly, Rear
--	532 14 43-34	Sealant, Tire (10 oz. Tube)

NOTE: All component dimensions given in U.S. inches
1 inch = 25.4 mm

TRACTOR - - MODEL NO. TS 346 (96041037200), PRODUCT NO. 960 41 03-72

SCHEMATIC **38**

SCH28

SMART IGNITION SWITCH (S.I.S.)



-DO NOT OPEN!
-PERMANENT DAMAGE CAN RESULT
IF PROPER DIAGNOSTIC PROCEDURES
ARE NOT FOLLOWED.
-CONTACT YOUR DEALER OR AUTHORIZED
SERVICE CENTER FOR REPAIR.



SENSITIVE ELECTRONIC
COMPONENTS INSIDE!



(COLOR: CONNECTOR NUMBER - PIN NUMBER)

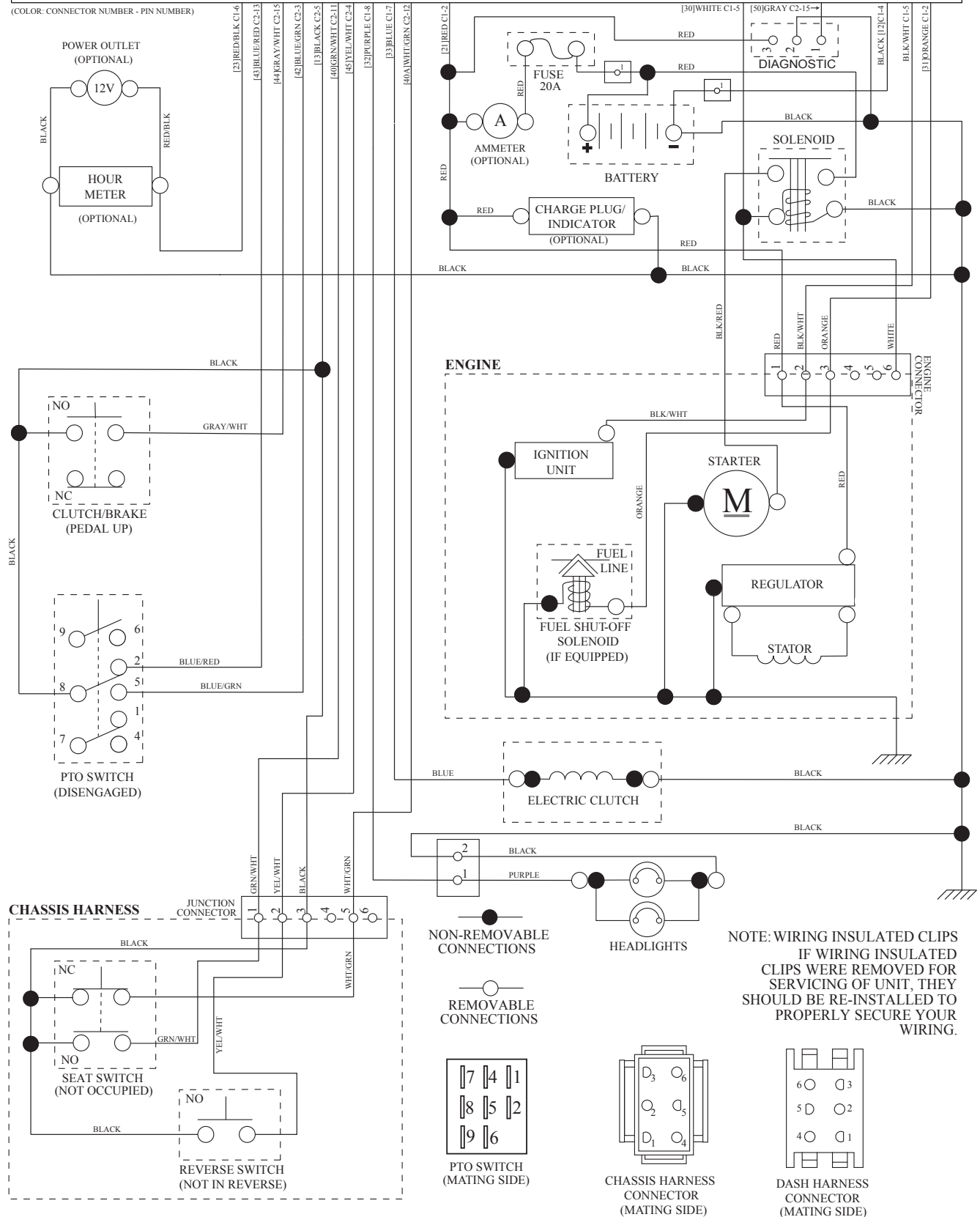

NON-REMOVABLE
CONNECTIONS

REMOVABLE
CONNECTIONS

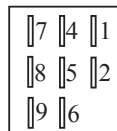

PTO SWITCH
(MATING SIDE)

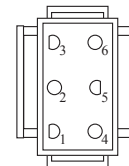

CHASSIS HARNESS
CONNECTOR
(MATING SIDE)

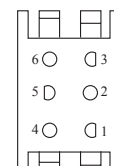

DASH HARNESS
CONNECTOR
(MATING SIDE)

NOTE: WIRING INSULATED CLIPS
IF WIRING INSULATED
CLIPS WERE REMOVED FOR
SERVICING OF UNIT, THEY
SHOULD BE RE-INSTALLED TO
PROPERLY SECURE YOUR
WIRING.

**TRACTOR - - MODEL NO. TS 346 (96041037200), PRODUCT NO. 960 41 03-72
ELECTRICAL 32**

KEY PART NO.	NO.	DESCRIPTION
1	532 16 34-65	Battery
2	874 76 04-12	Bolt Hex Hd. 1/4-20 unc x 3/4
8	587 20 51-01	Battery Box
16	532 17 61-38	Switch Interlock
21	585 43 64-01	Harness Light
24	585 73 43-01	Cable Battery
25	585 55 55-01	Cable Starter
26	532 17 51-58	Fuse
27	873 51 04 00	Nut Keps Hex 1/4-20 unc
28	585 30 69-01	Cable Ground
29	581 42 93-02	Switch Seat
30	586 83 67-01	Switch Asm. Smart
40	585 26 36-02	Harness Ign. Dash
41	817 72 04-08	Screw 1/4-20 x 1/2
42	532 13 15-63	Cover Terminal
43	582 04 28-01	Solenoid
45	587 55 39-03	Ammeter Guage Round
46	587 55 40-03	Hourmeter Gauge
50	582 10 76-01	Switch PTO
55	817 06 05-12	Screw 5/16-18 x 3/4
71	585 21 60-01	Harness Ign. Chassis
90	532 43 53-95	Cover Terminal Battery
99	817 67 04-12	Screw Hex Wsh. Thdrol. 1/4-20 x 3/4
100	819 09 14-16	Washer 9/32 x 7/8 x 16 Ga.
102	532 40 44-54	Harness Pigtail Tex ROS Tufftorq
105	532 40 75-68	Switch Reverse
142	583 85 78-01	Charge Port Pigtail
143	532 44 80-59	Charge Port

NOTE: All component dimensions given in U.S. inches
1 inch = 25.4 mm

**TRACTOR - - MODEL NO. TS 346 (96041037200), PRODUCT NO. 960 41 03-72
CHASSIS AND ENCLOSURES 39**

KEY NO.	PART NO.	DESCRIPTION	KEY NO.	PART NO.	DESCRIPTION
3	532 44 44-81	Applique Sub Asm.	199	532 19 82-59	Plate Deck Lift
5	581 67 41-02	Dash	202	532 43 97-28	Vent Side Hood RH
14	532 44 11-77	Hood	203	532 43 97-27	Vent Side Hood LH
15	585 42 03-01	Lens LH	204	532 43 57-14	Vent Asm. Hood Top
18	532 44 06-53	Grille	205	532 43 97-30	Trim Hood Side RH
25	585 42 02-01	Lens RH	206	532 43 97-29	Trim Hood Side LH
34	580 91 08-01	Plate Engine	207	585 42 00-01	Bezel RH
36	817 06 05-12	Screw 5/16-18 x 3/4	208	585 42 01-01	Bezel LH
37	532 44 12-08	Fender	213	874 76 05-12	Bolt Hex Hd. 5/16-18 unc x 3/4
52	873 68 05-00	Nut Crownlock 5/16-18	214	532 19 91-45	Clip Retainer
58	532 41 22-81	Drawbar Upper	217	532 40 91-67	Rod Pivot
68	817 49 05-08	Screw 5/16-18 x 1/2	218	532 19 63-95	Hood Stop
125	581 68 48-01	Clip Fuel Line	221	532 19 89-09	Reflector LH
130	532 41 63-58	Screw #10 x 0.750	228	532 19 51-61	Stud Fastener
137	532 40 75 90	Bumper Dash	235	532 40 61 29	Spacer Fender
146	581 85 79-01	Bolt	236	873 93 05-00	Nut 5/16-18 unc
150	532 43 97-74	Duct Heat Hood	296	585 42 05-01	LED Light LH
151	532 43 66-70	Pivot Bracket	297	586 18 29-01	Insert Reflective LH
152	532 43 98-70	Shield Browning/Debris	299	585 42 04-01	LED Light RH
159	817 00 06-12	Screw 3/8-16 x 3/4 BL	303	587 49 34-02	Shield Chassis Fren LH
161	532 43 99-29	Console Fuel Window	304	587 86 51-02	Shield Chassis Fren RH
162	532 14 24-32	Screw Hex Wsh. Hi-Lo 1/4 x 1/2	306	873 90 06-00	Nut 3/8-16 unc
165	532 19 68-26	Bracket Support Tank	307	587 52 03-01	Shield Upper Pedal
175	532 19 63-04	Crossmember	308	532 17 18-77	Bolt 5/16-18 unc x 3/4
176	532 40 07-76	Screw #10-24 x 5/8	321	587 52 02-01	Shield Upper LH
177	532 19 52-28	Bushing Steering	335	532 44 82-04	Lower Dash Cover RH
180	532 41 50-64	Chassis	336	532 44 53-09	Lower Dash Cover LH
182	532 40 68-59	Dash Lower	350	532 44 51-43	Clip X-mas Tree
183	874 52 05-20	Bolt 5/16-18 unc x 1-1/4	375	586 90 82-01	Dash Clip-On Bumper
184	587 55 41-01	Plug Dome	--	532 43 18-82	Kit Guard Brush
189	817 00 05-12	Screw 5/16-18 x 3/4	--	586 29 76-01	Plug Light Switch
191	586 18 28-01	Insert Reflective RH			
194	873 90 05-00	Nut Lock Hex Flange 5/16-18			
195	532 40 41-37	Plug 12 V Adapter			
196	532 43 97-16	Console Asm. Deck Lift			
197	589 20 46-02	Shield Drawbar			

NOTE: All component dimensions given in U.S. inches
1 inch = 25.4 mm

TRACTOR - - MODEL NO. TS 346 (96041037200), PRODUCT NO. 960 41 03-72
DRIVE **40**

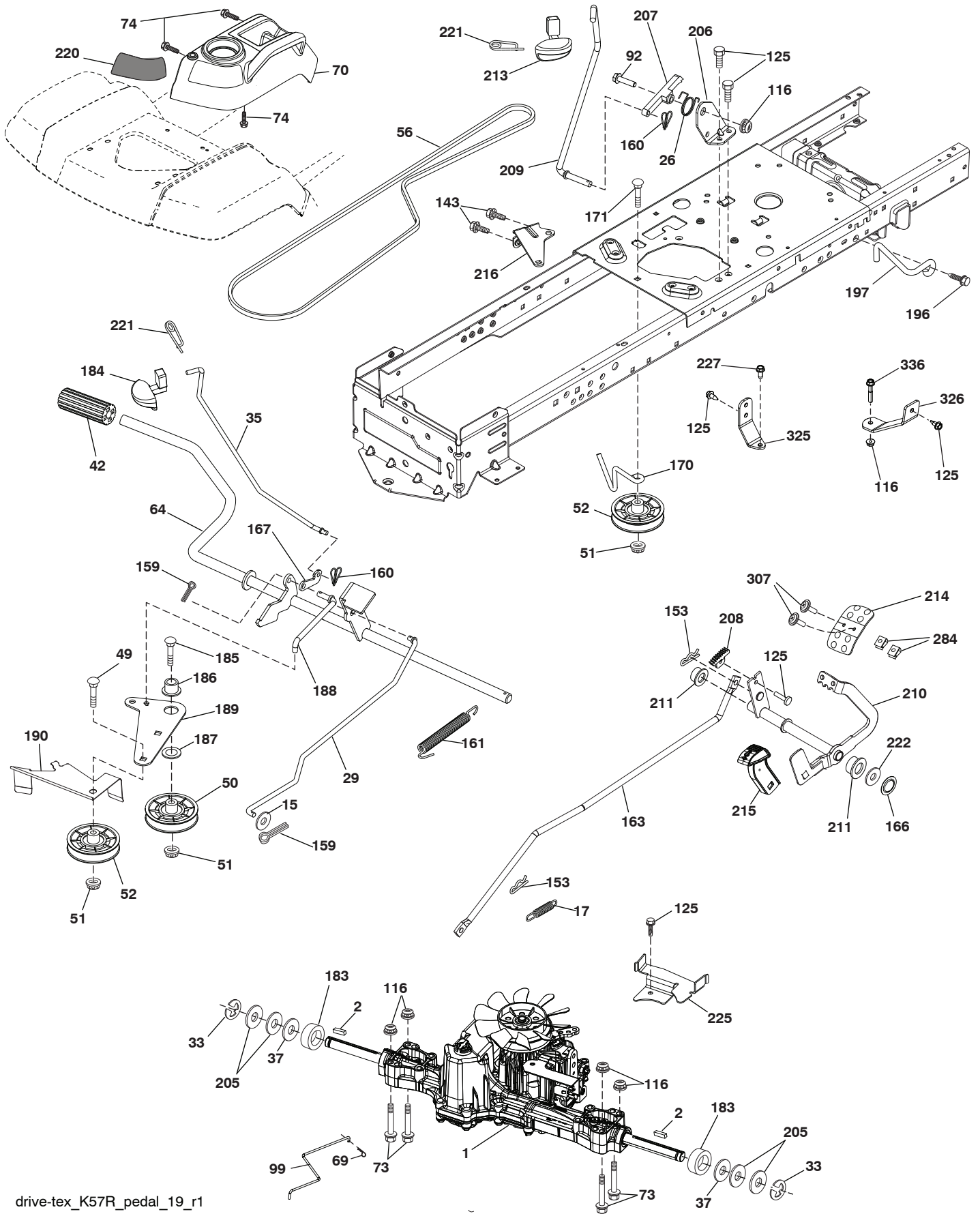

drive-tex_K57R_pedal_19_r1

**TRACTOR - - MODEL NO. TS 346 (96041037200), PRODUCT NO. 960 41 03-72
DRIVE 40**

KEY NO.	PART NO.	DESCRIPTION	KEY NO.	PART NO.	DESCRIPTION
1	- - - - -	Transaxle, TuffTorq K57R (437814) (Order parts from transaxle manufacturer.)	184	587 65 37-01	Handle Parking Brake
2	532 12 35-83	Key	185	872 11 06-22	Bolt
15	819 13 13-16	Washer 13/32 x 13/16 x 16 Ga.	186	532 19 43-21	Spacer Retainer
17	532 41 36-78	Spring, Brake	187	819 13 32-10	Washer
26	532 19 96-79	Spring Return Cruise	188	582 21 70-01	Link Clutch Ground Drive, Long
29	532 40 38-06	Rod, Brake	189	532 19 43-17	Bellcrank Ground Drive
33	812 00 00-01	Ring E	190	532 19 43-18	Keeper Bellcrank Ground Drive
35	583 86 45-01	Rod, Brake, Park	196	817 00 06-16	Screw 3/8-16 x 1
37	532 18 89-67	Washer Hardened	197	585 65 86-01	Link Clutch Anti-Rotation
42	532 12 48-72	Cover, Foot Pedal	205	532 12 17-48	Washer 25/32 x 1-5/8 x 16 Ga.
49	872 11 06-14	Bolt	206	532 44 85-96	Bracket Mount Latch Cruise
50	532 19 43-27	Pulley Idler Flat	207	587 03 14-01	Latch Control Cruise
51	873 90 06-00	Lock Nut 3/8-16	208	532 19 78-69	Gear Sector Control Cruise
52	532 19 43-26	Idler V-Groove	209	532 19 95-92	Rod Control Cruise
56	532 13 09-69	V-Belt, Drive	210	532 19 78-60	Rocker Asm Cruise
64	532 19 78-65	Shaft Asm. Pedal Brake Control	211	532 12 01-83	Bearing Nylon
69	532 42 33-03	Hairpin Soft Zink .059 x 1.125	213	532 40 31-19	Handle Parking Brake
70	532 43 96-61	Console Asm.	214	532 41 68-63	Pedal Forward Pad
73	874 49 05-40	Bolt 5/16-18 x 1/2 Gr 5	215	586 60 65-02	Pedal Reverse Pad
74	532 14 24-32	Screw Hx Wsh Hi-Lo 1/4 x 1/2 unc	216	532 19 61-31	Bracket Pulley Idler
92	874 76 05-20	Bolt Fin Hex 5/16-18 unc x 1.25	220	532 19 89-08	Reflector RH
99	582 40 45-01	Rod Bypass	221	532 40 31-87	Retainer Spring Clip Handle
116	873 90 05-00	Nut Lock Hex Flange 5/16-18	222	879 21 20-10	Washer 21/32 x 1-1/4 10 Ga.
125	817 00 05-12	Screw 5/16-18 x 3/4	225	532 40 33-19	Keeper Belt Trans.
143	817 49 05-08	Screw 5/16-18 x 1/2	227	817 49 05-12	Screw Thdrol 5/16-18 x 3/4
153	532 12 47-88	Retainer Spring	284	532 41 76-93	Nut U-Channel
159	876 02 04-12	Pin Cotter 1/8 x 3/4	307	874 18 04-12	Screw
160	532 16 94-84	Retainer Clip	325	585 66 85-02	Bracket
161	532 10 57-09	Spring, Return, Clutch	326	585 67 08-02	Bracket
163	532 44 82-75	Rod Pedal Control	336	587 25 96-01	Bolt
166	532 42 91-64	Nut Push .625			
167	532 40 52-57	Latch Brake Parking			
170	532 19 43-22	Keeper Belt Centerspan			
171	872 11 06-16	Bolt			
183	532 13 70-57	Spacer Axle			

NOTE: All component dimensions given in U.S. inches
1 inch = 25.4 mm

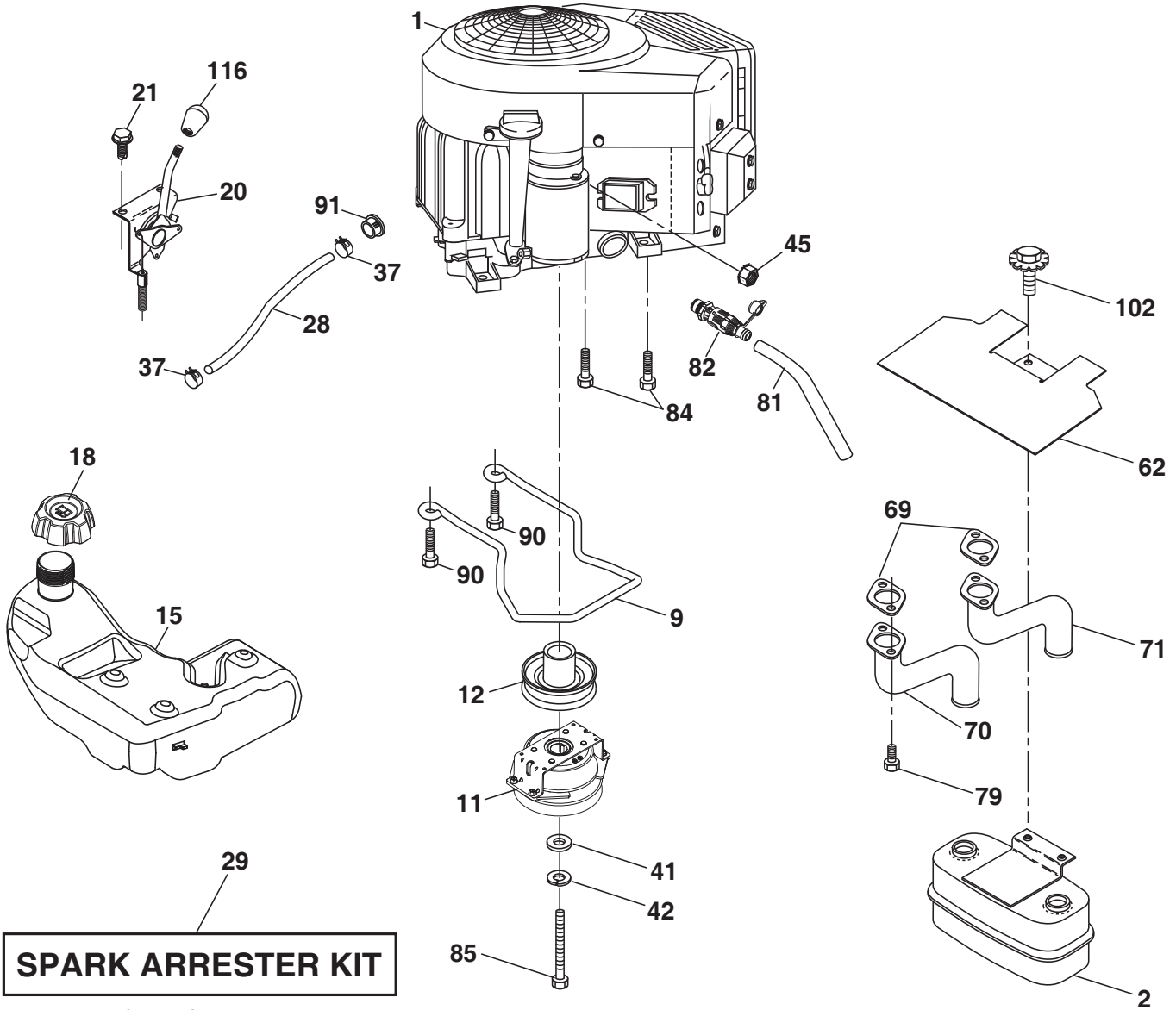

SPARK ARRESTER KIT

engine-tex_bs-2cyl_170

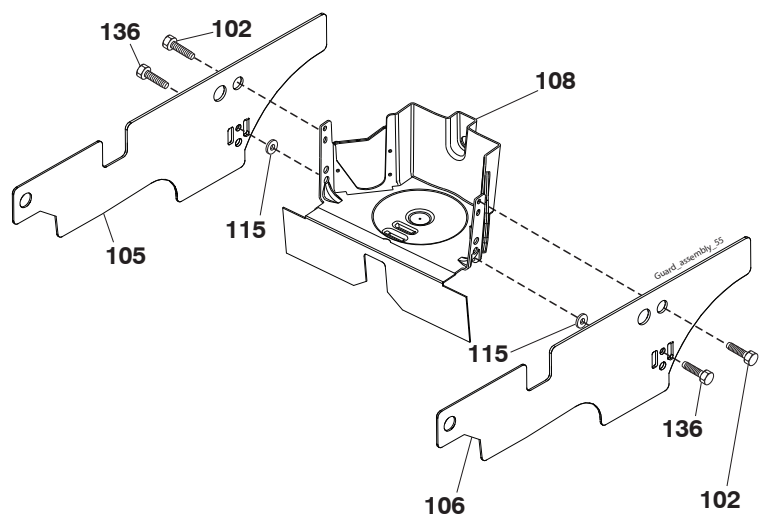

**TRACTOR - - MODEL NO. TS 346 (96041037200), PRODUCT NO. 960 41 03-72
ENGINE 24**

KEY NO.	PART NO.	DESCRIPTION
1	- - - - -	Briggs&Stratton 44U677-0005-B1 (590203501)(Order parts from engine manufacturer.)
2	589 81 87-01	Muffler
9	501 83 26-02	Keeper Belt Engine
11	587 24 16-01	Clutch Electric
12	532 40 50-97	Pulley Engine
15	532 19 34-99	Tank Fuel 4.0
18	584 24 87-01	Cap Fuel
20	587 24 27-01	Control Throttle/Choke
21	532 41 63-58	Screw #10 x 0.750
28	532 14 21-58	Fuel Line
29	532 13 71-80	Spark Arrester Kit
37	532 12 34-87	Clamp Hose
41	532 12 61-97	Washer 1-1/2 OD x 15/32 ID x .250
42	539 99 02-47	Washer Lock 7/16
45	873 51 04-00	Nut Keps 1/4-20 unc
62	532 43 40-17	Shield Heat Muffler
69	532 16 53-91	Gasket
70	581 88 11-01	Tube Exhaust LH
71	581 88 10-01	Tube Exhaust RH
79	532 18 39-06	Screw
81	532 14 84-56	Tube Drain Oil Easy
82	532 42 82-87	Valve Oil Drain
84	817 06 06-20	Screw
85	501 60 66-01	Bolt 7/16-20 x 3.75 Gr. 5
90	817 00 06-16	Screw 3/8-16 x 1
91	532 18 74-95	Bushing 1.375 OD
102	817 00 05-12	Screw 5/16-18 x 3/4
105	501 26 86-02	Shield Side LH
106	501 26 87-02	Shield Side RH
108	587 17 95-03	Cover Pulley Engine w/SHLD 46"
115	532 43 17-61	Palnut #10
116	539 13 26-24	Knob Shift
136	532 42 17-56	Screw, #10 0.500, BOS

NOTE: All component dimensions given in U.S. inches
1 inch = 25.4 mm

TRACTOR - - MODEL NO. TS 346 (96041037200), PRODUCT NO. 960 41 03-72
STEERING ASSEMBLY **41**

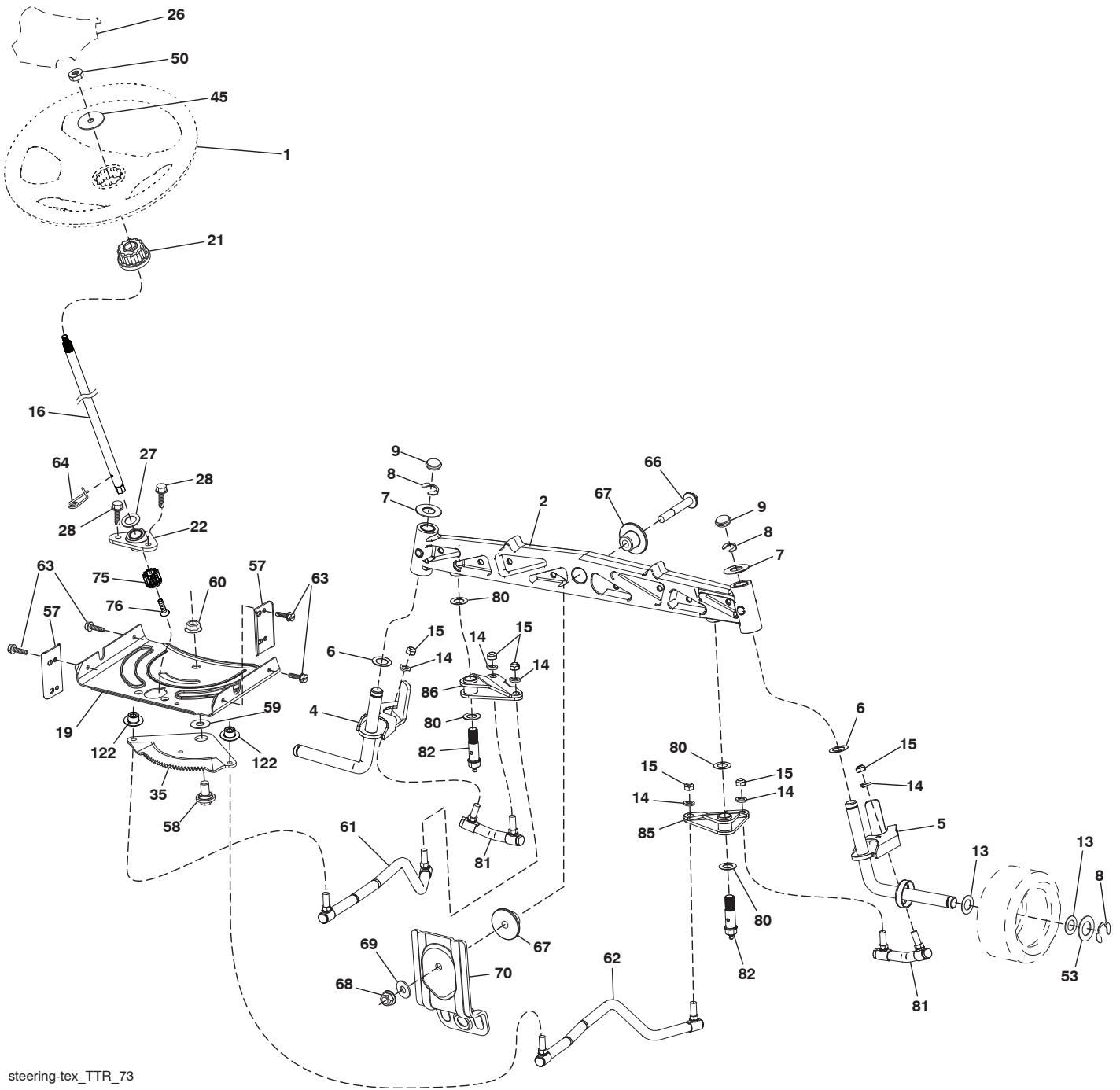

steering-tex_TTR_73

TRACTOR - - MODEL NO. TS 346 (96041037200), PRODUCT NO. 960 41 03-72
STEERING ASSEMBLY 41

KEY NO.	PART NO.	DESCRIPTION
1	532 43 97-40	Wheel, Steering
2	532 43 68-70	Axle Asm., Front
4	532 43 68-73	Spindle Asm., LH
5	532 43 68-74	Spindle Asm., RH
6	532 12 49-31	Washer Thrust 0.75 x 1.23
7	532 12 17-48	Washer 25/32 x 1-5/8 x 16 Ga.
8	812 00 00-29	Ring, Klip #T5304-75
9	532 12 12-32	Cap, Spindle
13	532 12 17-49	Washer 25/32 x 1-1/4 x 16 Ga.
14	539 99 01-18	Washer, SLW ZD 3/8
15	873 54 06-00	Nut, Crown Lock 3/8-24 unf
16	587 01 60-02	Shaft Steering
19	532 19 47-29	Plate Steering
21	586 84 02-01	Adapter, Wheel Steering Splnd Alum
22	585 02 99-01	Bearing Subasm Shaft Steer Low
26	532 43 97-43	Insert, Wheel Steering
27	819 21 16-16	Washer 21/32 x 1 x 16 Ga.
28	817 00 06-12	Screw 3/8-16 x 3/4
35	532 44 07-70	Gear, Sector Plate
45	587 01 64-01	Washer 3/8 ID 2-3/8OD 12 Ga. PLTD
50	873 90 06-00	Nut Lock Flg. 3/8-16 unc
53	532 18 89-67	Washer Hardened .793 x 1.637 x .060
57	532 40 74-65	Bracket Upstop
58	532 19 47-47	Bolt Shoulder Sector Pivot CFM
59	532 19 47-48	Washer Thrust Sector Steering
60	873 97 10-00	Nut Flange Lock 5/8-11
61	581 92 62-02	Draglink, LH
62	581 92 63-02	Draglink, RH
63	817 00 05-12	Screw 5/16-18 x 3/4
64	532 19 98-49	Retainer Clip Spring Steering
66	871 02 07-48	Bolt Hex Fghd 7/16-14 x 3 Serr
67	532 19 47-37	Bushing PM Front Axle
68	873 90 07-00	Nut Lock Flange 7/16-14 Gr. 5
69	532 19 91-62	Washer 1.5 x .505 x .118
70	585 33 88-01	Bracket Deck Susp. Front
75	580 68 37-01	Pinion
76	580 68 36-01	Screw Head Sock
80	532 00 13-70	Washer
81	532 43 68-87	Link Cross RH
82	532 44 21-47	Pivot Bolt
85	532 44 18-73	Pivot RH
86	532 44 18-72	Pivot LH
122	532 44 49-62	Cap Gear Sector TFX

NOTE: All component dimensions given in U.S. inches
1 inch = 25.4 mm

TRACTOR - - MODEL NO. TS 346 (96041037200), PRODUCT NO. 960 41 03-72
MOWER DECK 44

KEY NO.	PART NO.	DESCRIPTION	KEY NO.	PART NO.	DESCRIPTION
1	589 53 53-08	Mower Housing	188	532 19 51-61	Stud Fastener
4	874 76 05-12	Bolt Hex Hd 5/16-18 unc	189	873 90 05-00	Nut Lock Hex Flange
6	532 19 51-86	Arm Suspension	197	819 13 13-12	Washer 13/32 x 13/16 x 12 Ga.
11	581 04 39-01	Blade Mower	198	532 40 31-49	Baffle Center Front
13	580 85 47-01	Shaft Asm. Rev. Tall	199	532 40 31-50	Baffle Front RH
14	580 79 61-01	Housing, Mandrel	200	532 41 35-24	Washer 13/32 x 1 x 1/2 11 Ga.
15	585 32 39-01	Bearing, Mandrel	208	817 67 06-08	Screw THDROL 3/8-16 x 1/2
19	532 19 65-39	Bolt, Shoulder	209	588 80 88-01	Cover Asm Mandrel LH
21	873 68 05-00	Nut	210	532 43 23-96	Cover Asm Mandrel RH
23	532 19 25-57	Bracket, Deflector	241	532 15 29-27	Screw
24	532 10 53-04	Cap, Sleeve	242	532 41 55-98	Washout Port
25	532 19 70-26	Spring, Torsion, Deflector	246	580 95 40-03	Blade Holder
26	532 11 04-52	Nut, Push	247	532 43 02-63	Shield Deck RH
27	532 44 28-95	Shield, Deflector	248	532 43 02-62	Shield Deck LH
29	532 13 14-91	Rod, Hinge	250	532 42 30-62	Palnut 1/4
32	532 19 74-73	Pulley, Mandrel	253	532 42 73-50	Rivet
33	532 40 02-34	Nut, Toplock, Flanged	254	532 43 02-64	Cover Asm Rear
34	872 11 06-12	Bolt Carr Sh. 3/8-16 x 1-1/2 Gr. 5	255	532 43 60-87	Kit Bungee
36	532 19 73-79	Pulley, Idler, Flat	256	539 10 98-00	Carriage Bolt 1/4-20 x 1 Gr. 5
40	873 90 06-00	Nut, Lock Flg. 3/8-16 unc	257	873 90 04-00	Nut Hex Flange 1/4-20 unc
41	584 95 39-01	Bolt Hex Washer Head 3/8-16 x 1.19	261	589 48 18-05	Plate Reinforcement Front
46	532 13 77-29	Screw	262	589 48 20-05	Plate Reinforcement Side
47	584 30 93-01	Screw	263	586 63 85-01	Upper/Lower Cap Asm.
55	532 19 72-49	Arm, Idler	--	587 12 61-05	Mandrel Assembly-Tall (Includes Housing (Key #14), Shaft Assembly (Key #13), and Bearing Only (Key #15) Pulley/Nut/Washer and Blade Bolt/Washers Not Included)
56	532 19 90-92	Spacer, Retainer			
57	817 00 06-16	Screw Hexwsh Thd 3/8-16 x 1			
59	532 14 10-43	Guard, Tuv Idler (94)			
62	874 52 06-36	Bolt 3/8-16 unc x 2-1/4 Gr. 5			
68	532 40 51-43	V-Belt	--	586 26 49-01	Replacement Mower, Complete
69	872 14 05-05	Bolt			
116	532 19 34-06	Bolt, Shoulder			
117	532 17 48-73	Wheel, Gauge			
119	819 13 20-12	Washer 13/32 x 1-1/2 x 11 Ga.			
145	532 19 31-97	Pulley Idler			
147	532 19 72-51	Spring Return			

NOTE: All component dimensions given in U.S. inches
1 inch = 25.4 mm

TRACTOR - - MODEL NO. TS 346 (96041037200), PRODUCT NO. 960 41 03-72
MOWER LIFT 45

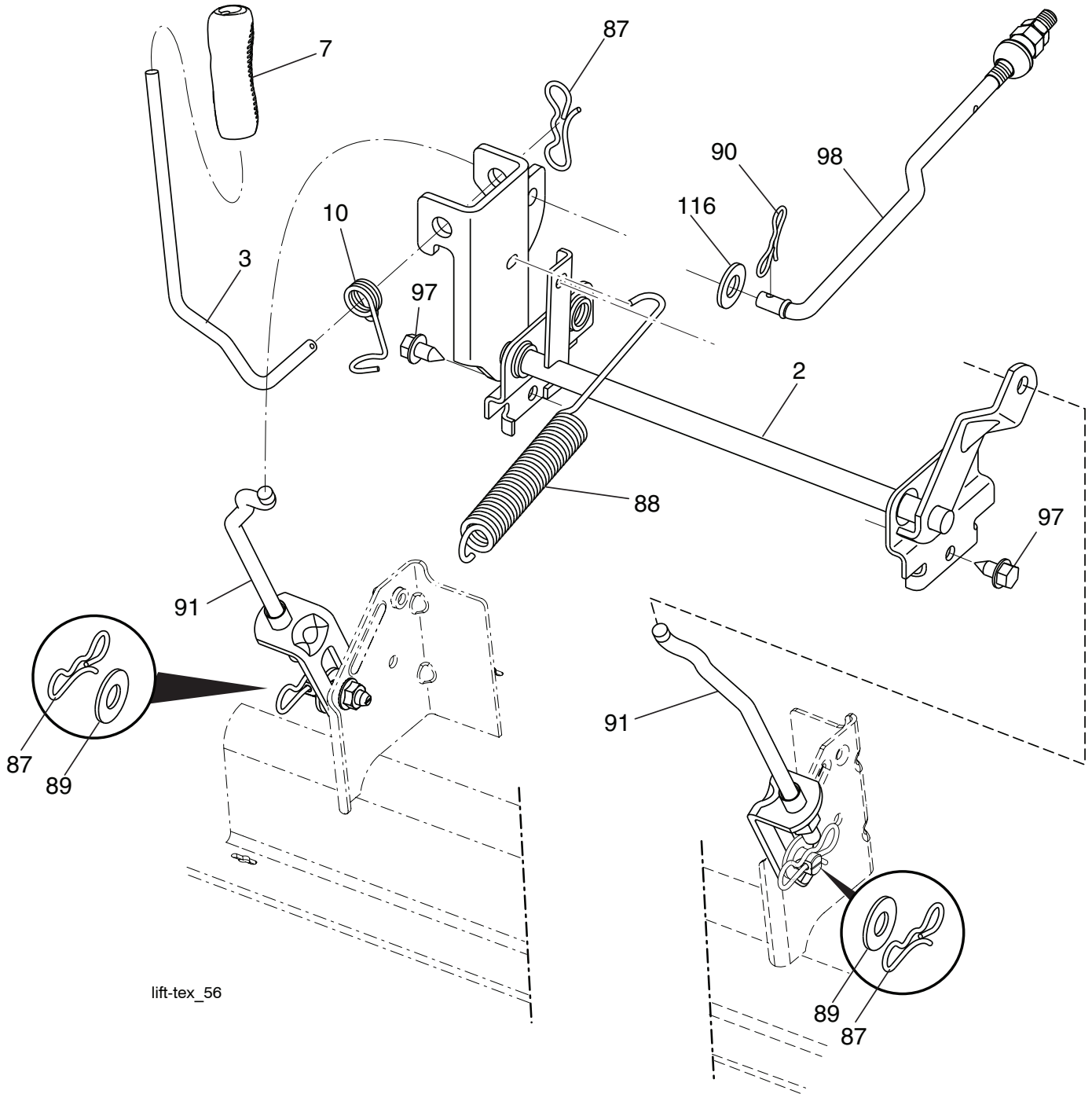

KEY NO.	PART NO.	DESCRIPTION
2	532 42 20-27	Shaft Asm., Lift
3	532 19 52-30	Lever Asm., Lift RH
7	580 96 23-01	Grip, Lever
10	532 19 63-14	Spring Torsion
87	532 19 42-09	Pin Cotter 7/16 Bow Tie Lock
88	532 41 07-10	Spring Lift Assist
89	819 19 19-12	Washer Clear Zinc
90	532 19 42-08	Pin Cotter 5/16 Bow Tie Lock

KEY NO.	PART NO.	DESCRIPTION
91	532 19 51-81	Lift Link Asm. Rear
97	817 00 06-12	Screw 3/8-16x.75 Smgml. Tap/R.Z
98	532 19 52-70	Link Asm. Susp. Front Mower
116	819 15 15-16	Washer 15/32 x 15/16 x 16 Ga.

NOTE: All component dimensions given in U.S. inches
 1 inch = 25.4 mm

**TRACTOR - - MODEL NO. TS 346 (96041037200), PRODUCT NO. 960 41 03-72
SEAT ASSEMBLY 42**

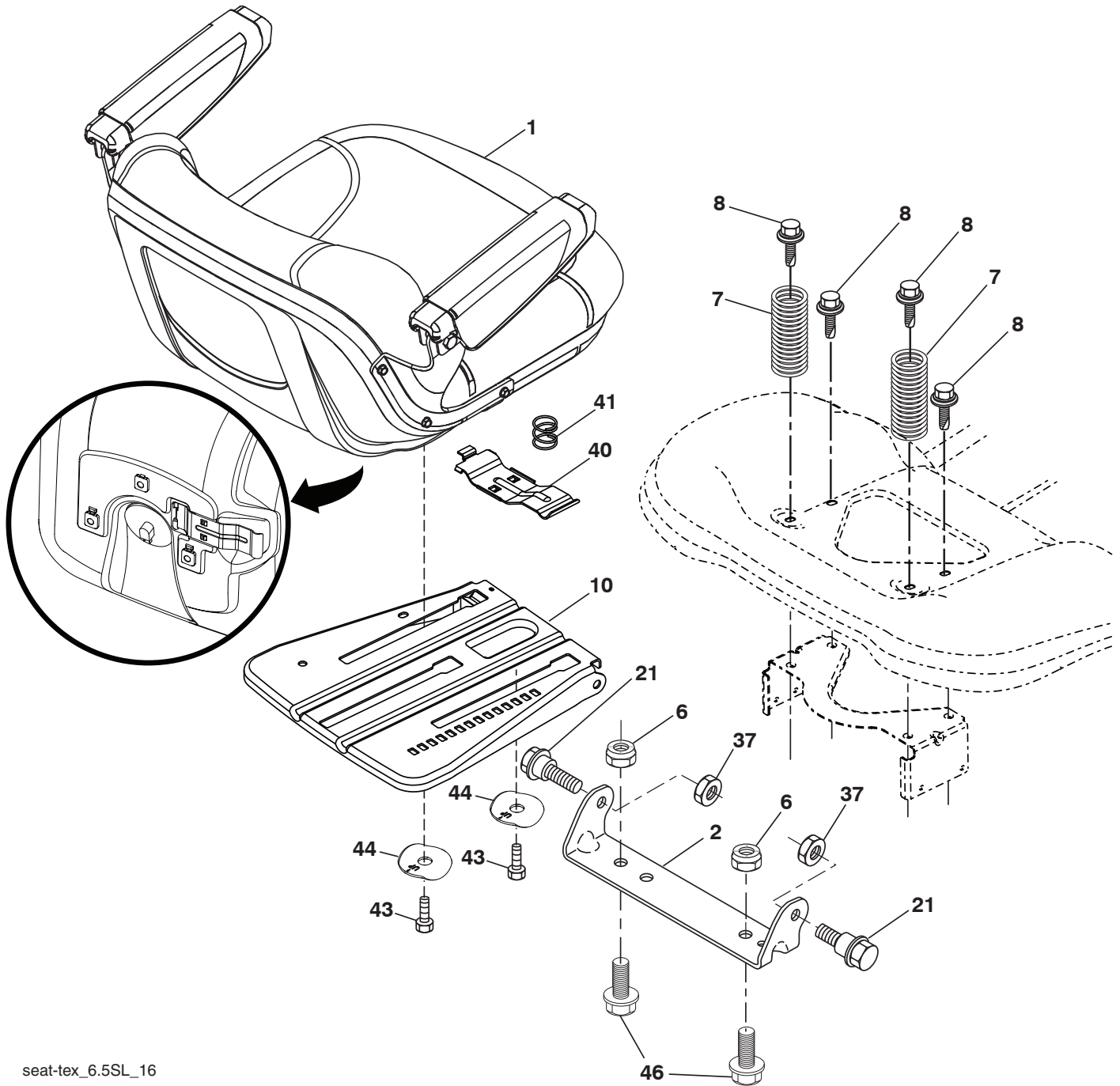

seat-tex_6.5SL_16

KEY NO.	PART NO.	DESCRIPTION
1	588 55 67-01	Seat
2	532 18 01-66	Bracket Pivot Fender
6	873 80 06-00	Nut, Lock W/Ins. 3/8-16 unc
7	589 48 35-01	Spring, Seat Cprsn
8	532 17 18-77	Bolt 5/16-18 unc x 3/4 w/Sems
10	587 23 20-02	Pan, Seat
21	587 90 78-01	Bolt, Shoulder 5/16-18 X 5/8
37	873 80 05-00	Nut, Lock 5/16-18 unc

KEY NO.	PART NO.	DESCRIPTION
40	532 19 76-61	Handle Slide Seat
41	532 19 82-00	Spring Latch Seat
43	874 76 06-12	Bolt Fin Hex 3/8-16 unc x 3/4
44	501 05 18-01	Washer Winged 3/8 ID 1.25 OD
46	588 09 04-01	Bolt 3/8-16 x 1, 1.25

NOTE: All component dimensions given in U.S. inches
1 inch = 25.4 mm

