

ILLUSTRATED PARTS LIST

MODEL NO. 96051012300

CUSTOMER CATALOG NO. TC 130

PRODUCT NO. 960 51 01-23

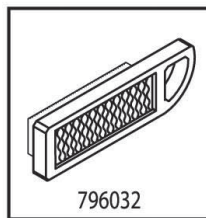

47

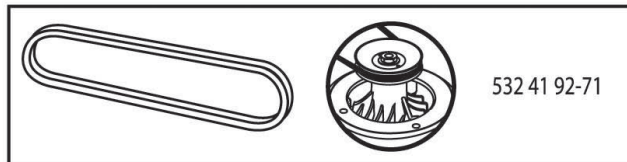

442548

TRACTOR - MODEL NO. TC 130 (96051012300), PRODUCT NO. 960 51 01-23
DECALS 27

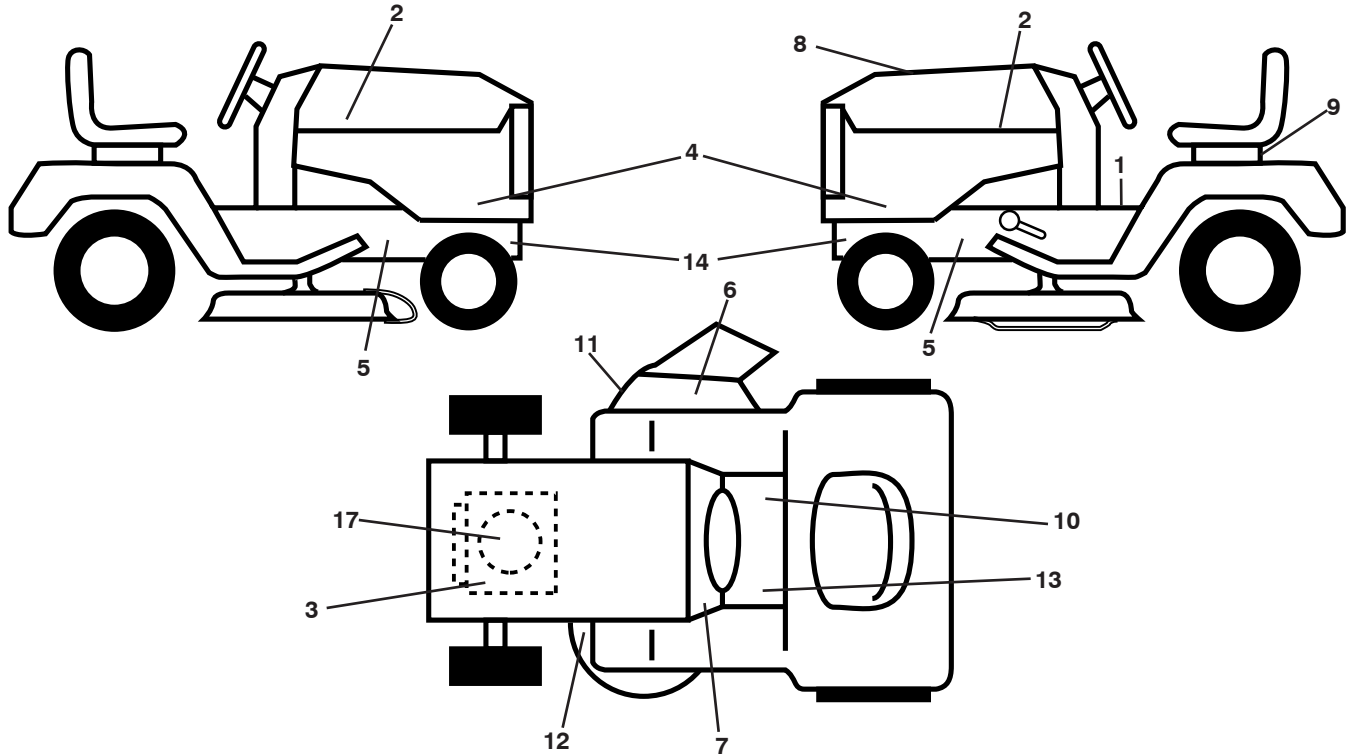

KEY NO.	PART NO.	DESCRIPTION
1	581 57 81-01	Decal, Operators
2	581 62 73-01	Decal, Hood Logo
3	581 57 97-01	Decal, Warning Eng. Symbols
4	587 39 64-01	Decal, Hood Panel
5	581 57 96-01	Decal, Chassis Hot Muffler
6	584 90 46-01	Decal, Deck/Deflect. Warning
7	586 06 62-01	Decal, Snowflake
8	532 44 25-48	Decal, Rpl
9	532 14 50-05	Decal, Battery Dnge/Poi
10	581 57 80-01	Decal, Saddle Brake Parking
11	581 57 94-01	Decal, Warning DFlect/Ctfrng

KEY NO.	PART NO.	DESCRIPTION
12	581 58 00-04	Decal, Mower V-Belt Schematic
13	581 72 40-01	Decal, Brake/Clutch Symbol
14	581 57 98-01	Decal, Warning
17	587 38 50-01	Decal, BS Engine
--	581 72 48-01	Decal, Bypass
--	532 44 14-09	Pad, Footrest, LH
--	532 44 14-10	Pad, Footrest, RH
--	588 89 32-20	Manual Oper. Euro
--	588 89 32-10	Manual Oper. Scan
--	588 89 32-50	Manual Oper. E-Bloc
--	588 89 32-40	Manual Oper. Baltic

WHEELS AND TIRES

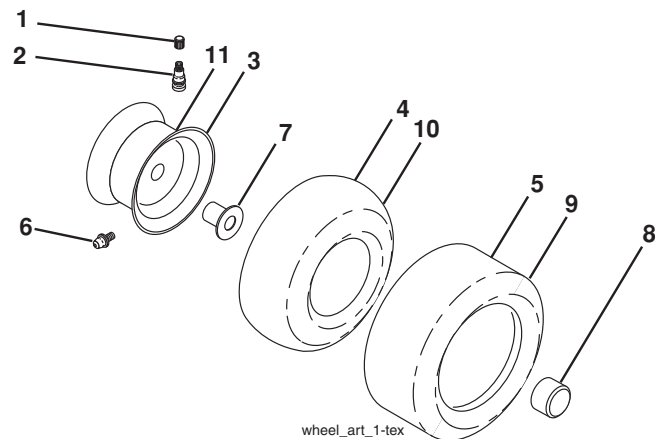

KEY NO.	PART NO.	DESCRIPTION
1	532 05 91-92	Cap Valve Tire
2	532 06 51-39	Stem Valve
3	532 42 52-61	Rim Asm 6 x 3.25 Front
4	532 42 16-52	TubeFront13x5-6(ServiceItemOnly)
5	532 12 34-10	Tire Front 13 x 5-6
6	532 12 49-57	Fitting Grease (Front Wheel Only)
7	532 12 49-59	Bearing Flange (Front Wheel Only)
8	532 17 50-39	Cap Axle Blk 1 50 x 1 00
9	532 10 62-30	Tire Rear 16 x 6.5-8
10	532 00 71-54	Tube Rear (Service Item Only)
11	532 42 52-62	Rim Asm 8 x 5.375 Rear
--	532 14 43-34	Sealant, Tire (10 oz. Tube)

NOTE: All component dimensions given in U.S. inches
 1 inch = 25.4 mm

TRACTOR - MODEL NO. TC 130 (96051012300), PRODUCT NO. 960 51 01-23
ELECTRICAL 32

S02S

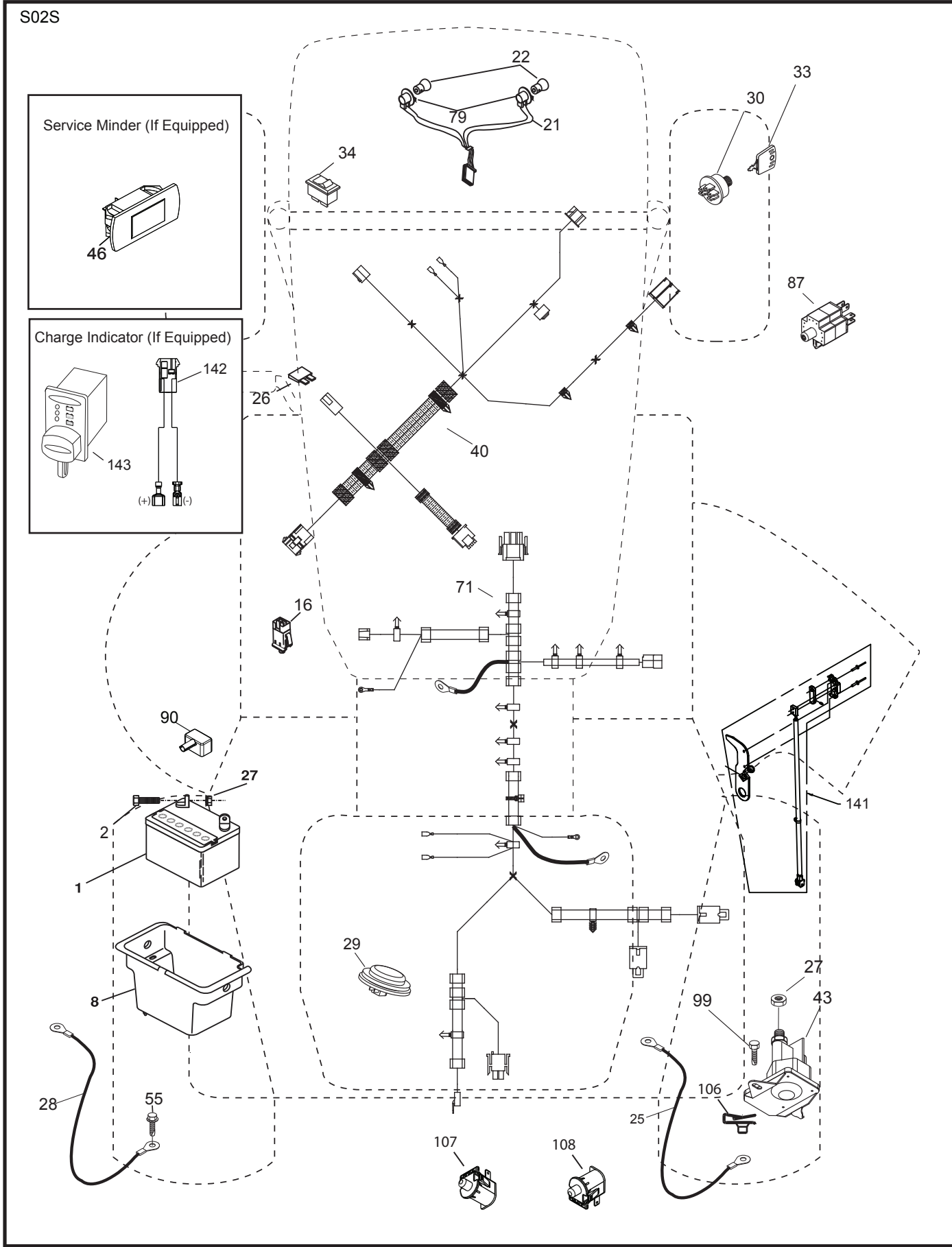
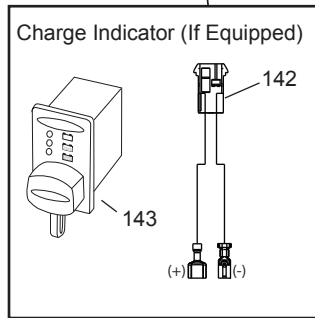
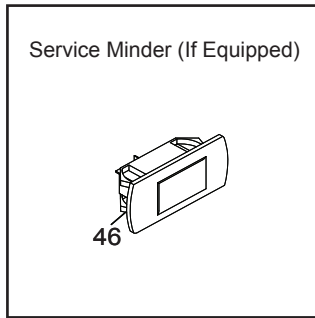

**TRACTOR - MODEL NO. TC 130 (96051012300), PRODUCT NO. 960 51 01-23
ELECTRICAL 32**

KEY NO.	PART NO.	DESCRIPTION
1	532 16 34-65	Battery
2	874 76 04-12	Bolt Hex Head 1/4-20 x 3/4
8	532 41 97-91	Box Battery
16	532 17 61-38	Switch Interlock Push-In
21	532 40 02-52	Harness Socket Light w/4152J
22	532 00 41-52	Bulb Light
25	532 41 66-94	Cable Starter
26	532 17 51-58	Fuse
27	873 51 04-00	Nut Keps Hex 1/4-20 unc
28	532 42 16-86	Cable, Ground
29	532 40 15-45	Switch, Seat
30	532 19 33-50	Switch, Ign
33	532 41 19-35	Key/Chain
34	532 11 07-12	Switch Light/Reset
40	585 84 99-01	Harness Ign. Dash
43	532 19 25-07	Solenoid
55	817 06 05-12	Screw Thdrol 5/16-18 x 3/4 TYTT
71	501 13 34-01	Harness Ign. Chassis
79	532 17 52-42	Socket Asm. Bulb
87	532 42 10-60	Switch Railmount NO-NC-NC
90	532 43 53-95	Cover Terminal
99	817 67 04-12	Screw 1/4-20 x 3/4
106	532 17 48-14	Nut Speed 1/4-20
107	532 42 10-61	Switch Snapmount No #2
108	532 42 10-62	Switch Snapmount NC
141	532 41 69-77	Kit T2 ROS
142	583 85 78-01	Charge Port Pigtail
143	532 44 80-59	Charge Port

NOTE: All component dimensions given in U.S. inches
1 inch = 25.4 mm

TRACTOR - MODEL NO. TC 130 (96051012300), PRODUCT NO. 960 51 01-23
CHASSIS AND ENCLOSURES 39

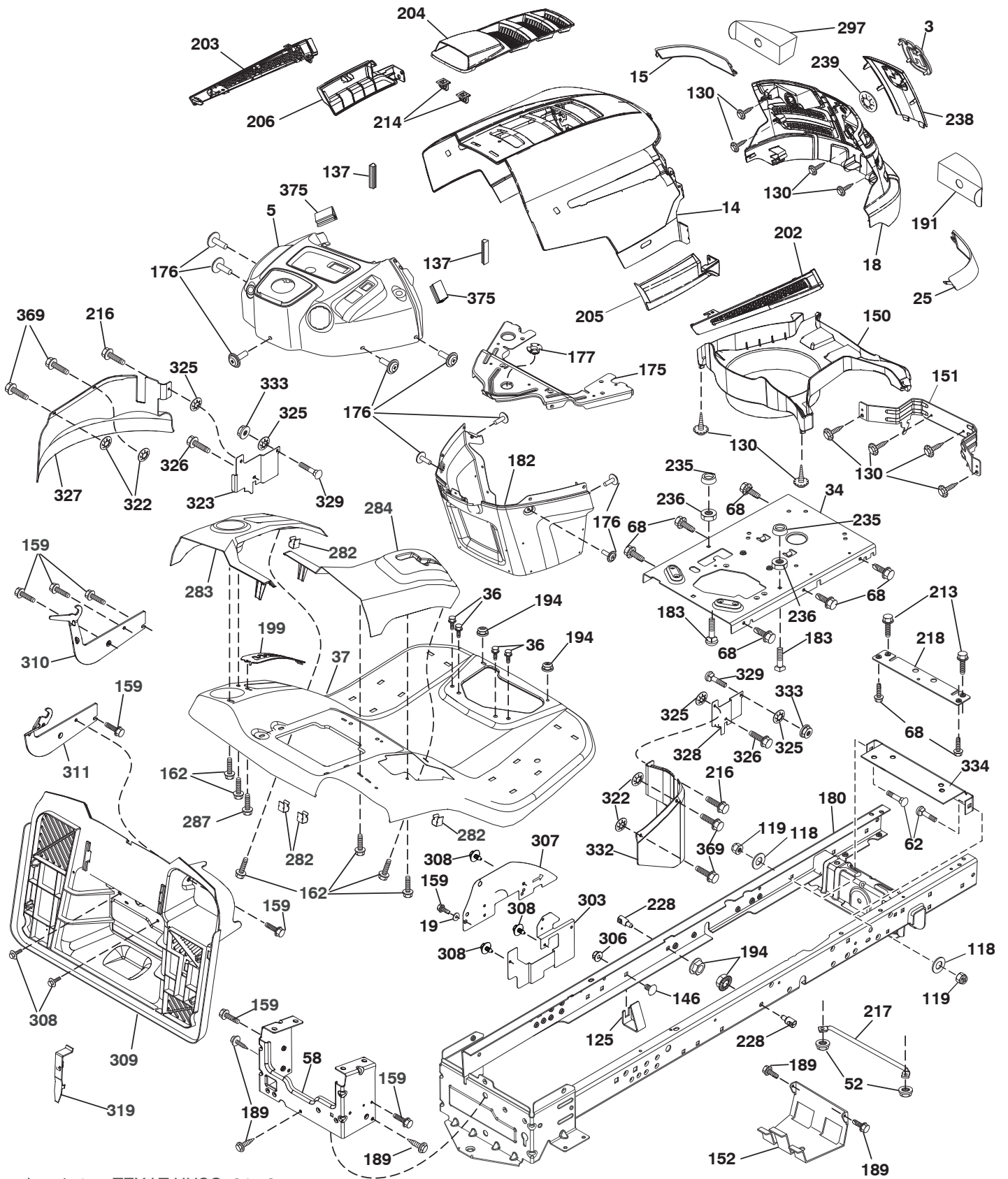

chassis-tex_TEX LT HUSQ_84_r2

**TRACTOR - MODEL NO. TC 130 (96051012300), PRODUCT NO. 960 51 01-23
CHASSIS AND ENCLOSURES 39**

KEY NO.	PART NO.	DESCRIPTION	KEY NO.	PART NO.	DESCRIPTION
3	581 05 63-01	Logo	216	817 67 05-08	Screw Thdrol. 5/16-18 x 1/2
5	585 47 79-06	Dash	217	532 40 91-67	Rod Pivot Hood
14	532 44 12-67	Hood	218	532 19 63-95	X-Piece Hood Stop
15	532 44 14-28	Lens LH	228	532 19 51-61	Stud Fastener
18	532 44 13-68	Grille	235	532 40 61-29	Spacer Fender
19	819 13 13-12	Washer 13/32 x 13/16 x 12 Ga.	236	873 93 05-00	Nut Lock 5/16-18 unc
25	532 44 14-27	Lens RH	238	532 44 13-74	Trim
34	580 91 09-01	Plate Engine	239	532 40 48-83	Clip Tinnerman
36	817 06 05-12	Screw 5/16-18 x 3/4	282	532 41 41-10	Clip Retainer
37	532 44 13-69	Fender	283	532 44 05-31	Console Deck Lift
52	873 68 05-00	Nut Crown Lock 5/16	284	532 44 05-30	Console Shift
58	532 41 22-80	Drawbar Upper	287	817 60 04-06	Screw Hex Washhead 1/4-20 x 3/8
62	872 11 06-08	Bolt RDHD SQNK 3/8 x 1 Gr. 5	297	532 40 66-65	Insert Reflective LH
68	817 49 05-08	Screw Thdrol. 5/16-18 x 1/2	303	587 49 31-02	Shield Chassis French
118	819 13 13-16	Washer 13/32 x 13/16 x 16 Ga.	306	873 90 06-00	Nut Lock
119	873 68 06-00	Nut Crownlock 3/8-16 unc	307	587 49 45-01	Shield Upper
125	581 68 48-01	Clip Fuel Line	308	532 17 18-77	Bolt 5/16-18 unc x 3/4
130	532 41 63-58	Screw #10 x 0.750 BOS Thread	309	532 43 02-46	Backplate Bagger SRD
137	532 40 75-90	Bumper Dash	310	532 44 54-28	Bracket Hangar Bag LH
146	581 85 79-01	Bolt	311	532 44 54-30	Bracket Hangar Bag RH
150	532 40 66-62	Air Duct	319	532 17 46-62	Bracket Actuator Bagger
151	532 40 78-07	Bracket Pivot	322	532 42 30-62	Palnut 1/4
152	532 19 95-35	Shield Browning	323	532 43 14-88	Guard French
159	817 00 06-12	Screw Kexwsh Thdr 3/8-16 x 3/4	325	532 42 30-63	Palnut 5/16
162	532 14 24-32	Screw Hex Wsh. Hi-Lo 1/4 x 1/2 unc	326	817 06 04-10	Screw Hex
175	532 19 94-72	Crossmember	327	532 43 14-83	French Guard
176	532 40 07-76	Screw 10-24 x 5/8	328	532 43 14-87	French Guard
177	532 19 52-28	Bushing Steering	329	872 14 05-05	Bolt 5/16-18 x 5/8
180	532 41 46-85	Chassis	332	532 43 14-82	French Guard
182	532 40 71-76	Dash Lower	333	873 80 05-00	Nut Lock 5/16-18
183	874 52 05-20	Bolt 5/16-18 x 1-1/4	334	532 44 25-37	Bracket Engine
189	817 00 05-12	Screw 5/16-18 x 3/4	369	532 42 17-56	Screw, #10 x 0.500, BOS
191	532 41 65-01	Insert Reflective RH	375	586 90 82-01	Dash Clip-On Bumper
194	873 90 05-00	Nut Lock Hex Flange 5/16-18	--	532 43 99-76	Plug Dash SVC Minder
199	532 41 87-39	Plate Deck Lift			
202	532 44 13-42	Vent Side Hood RH			
203	532 44 13-43	Vent Side Hood LH			
204	532 44 13-75	Vent Top Hood			
205	532 44 13-44	Skirt Side RH			
206	532 44 13-45	Skirt Side LH			
213	874 76 05-12	Bolt 5/16-18 x 3/4			
214	532 19 91-45	Clip Retainer			

NOTE: All component dimensions given in U.S. inches
1 inch = 25.4 mm

TRACTOR - MODEL NO. TC 130 (96051012300), PRODUCT NO. 960 51 01-23
DRIVE **40**

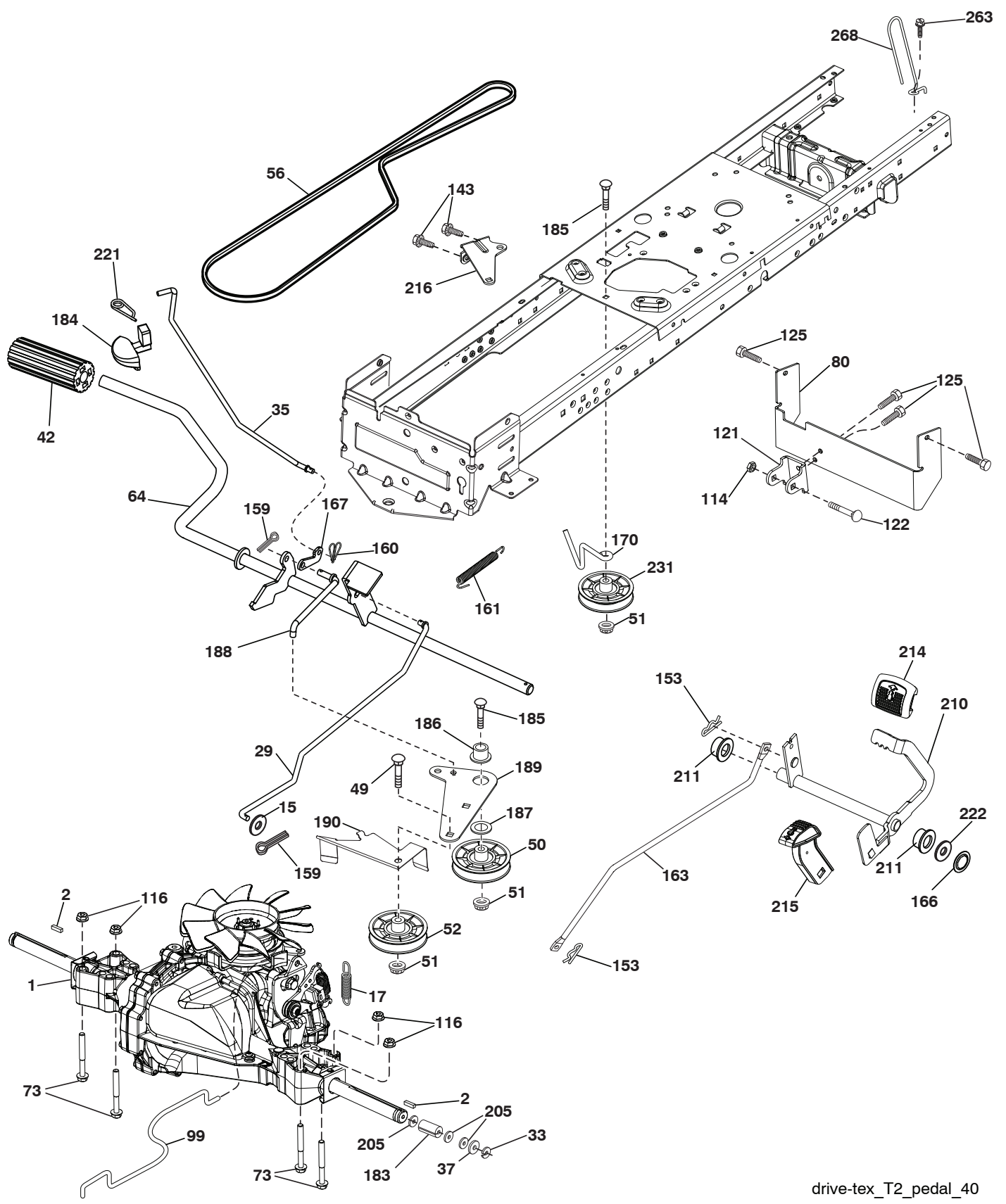

drive-tex_T2_pedal_40

**TRACTOR - MODEL NO. TC 130 (96051012300), PRODUCT NO. 960 51 01-23
DRIVE **40****

KEY NO.	PART NO.	DESCRIPTION	KEY NO.	PART NO.	DESCRIPTION
1	-----	Transaxle, Hydro Gear T2-BDBE-1X2B-18X1 (587392201) (Order parts from transaxle manufacturer.)	163	532 41 33-22	Rod Control
2	532 12 35-83	Key Square	166	532 42 91-64	Nut Push .625
15	819 13 13-16	Washer 13/32 x 13/16 x 16 Ga.	167	532 40 52-57	Latch Brake Parking
17	532 19 72-96	Spring, Brake	170	532 41 34-30	Keeper Belt Centerspan
29	532 42 32-39	Rod, Brake	183	532 15 69-72	Spacer Axle
33	812 00 00-01	Ring E	184	532 41 14-84	Handle Parking Brake
35	532 40 10-31	Rod, Brake, Park	185	872 11 06-22	Bolt
37	532 12 17-49	Washer 25/32 x 1-1/4 x 16 Ga.	186	532 19 43-21	Spacer Retainer
42	532 12 48-72	Cover, Foot Pedal	187	819 13 32-10	Washer
49	872 11 06-14	Bolt	188	582 21 70-01	Link Clutch Ground Drive, Long
50	532 19 43-27	Pulley Idler Flat	189	532 19 43-17	Bellcrank Ground Drive
51	873 90 06-00	Lock Nut 3/8-16	190	532 19 43-18	Keeper Bellcrank Ground Drive
52	532 19 43-26	Idler V-Groove Offset	205	532 12 17-48	Washer 25/32 x 1-5/8 x 16 Ga.
56	592 85 53-01	V-Belt, Drive	210	532 40 09-80	Rocker Asm. Pedal Control
64	532 19 78-65	Shaft Asm. Pedal Brake Control	211	532 12 01-83	Bearing Nylon
73	874 49 05-44	Bolt Hex 5/16-18 Gr. 5	214	532 42 12-63	Pedal Pad Forward
80	581 55 07-01	Strap Torque	215	586 60 65-02	Pedal Reverse
99	532 40 84-18	Rod Spring Bypass	216	532 19 61-31	Bracket Pulley Idler
114	873 80 05-00	Nut Lock 5/16-18 unc	221	532 40 31-87	Retainer Spring Clip Handle
116	873 90 05-00	Nut Lock Hex Flange 5/16-18	222	879 21 20-10	Washer 21/32 x 1-1/4 10 Ga.
121	532 17 56-11	Bracket Strap Torque	231	532 40 72-87	Idler V-Groove
122	872 01 05-20	Bolt 5/16-18 x 2.50	263	817 00 06-12	Screw Hexwsh THDR 3/8-16 x 3/4
125	817 00 05-12	Screw 5/16-18 x 3/4	268	532 18 24-02	Guard, Muffler
143	817 49 05-08	Screw THDROL 5/16-18 x 1/2			
153	532 12 47-88	Retainer Spring 1"			
159	876 02 04-12	Pin Cotter 1/8 x 3/4			
160	532 16 94-84	Retainer Clip			
161	532 10 57-09	Spring, Return, Clutch			

NOTE: All component dimensions given in U.S. inches
1 inch = 25.4 mm

TRACTOR - MODEL NO. TC 130 (96051012300), PRODUCT NO. 960 51 01-23
ENGINE 24

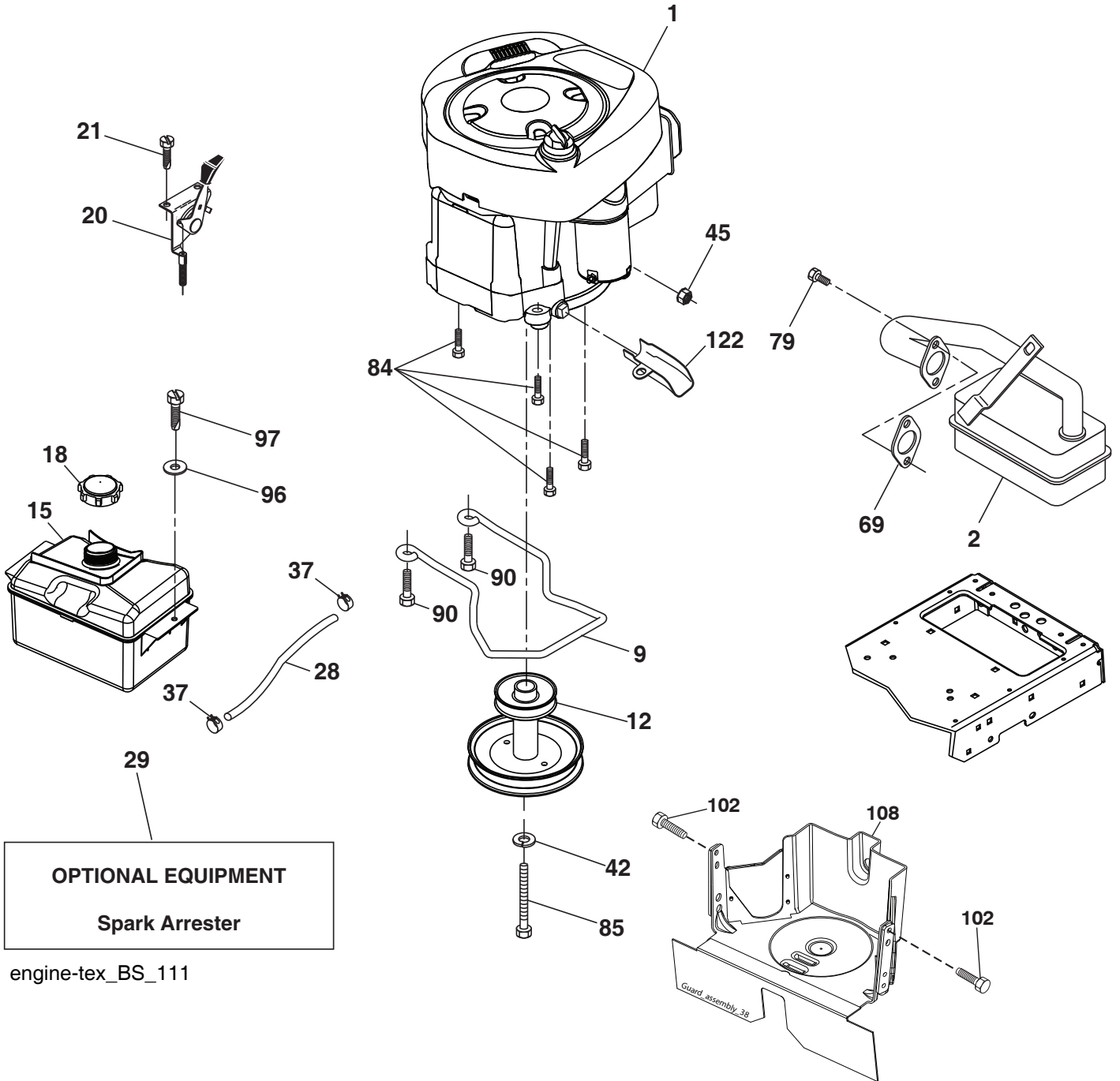

engine-tex_BS_111

**TRACTOR - MODEL NO. TC 130 (96051012300), PRODUCT NO. 960 51 01-23
ENGINE 24**

KEY NO.	PART NO.	DESCRIPTION
1	-----	Engine BS Model No. 21R777-0100-B1 (587355101) (Order Parts from engine manufacturer.)
2	532 17 97-58	Muffler
9	582 54 03-02	Keeper Belt Engine
12	532 14 01-86	Pulley Engine
15	581 28 99-01	Tank Fuel 1.5
18	532 43 02-20	Cap Asm
20	587 24 26-01	Control Throttle
21	532 41 63-58	Screw #10 x 0.750 BOS Thread
28	532 13 70-40	Fuel Line
29	532 13 71-80	Spark Arrester Kit
37	532 12 34-87	Clamp Hose
42	810 04 07-00	Washer Lock Hvy HLCL SPR 7/16
45	873 51 04-00	Nut Keps Hex 1/4-20 unc
69	532 16 52-91	Gasket
79	532 19 23-34	Screw Socket HD 5/16 - 18 x 75
84	817 06 06-20	Screw 3/8-16 x 1-1/4
85	532 17 39-37	Bolt Hex 7/16-20 x 4 Gr. 5-1.5
90	817 00 06-16	Screw 3/8-16 x 1
96	819 09 14-16	Washer 9/32 x 7/8 x 16 Ga.
97	817 67 04-12	Screw 1/4-20 x 3/4
102	817 00 05-12	Screw 5/16-18 x 3 x 4
108	587 17 95-04	Pulley Cover Engine w/SHLD 30"
122	532 42 19-22	Extension Drain Oil

NOTE: All component dimensions given in U.S. inches
1 inch = 25.4 mm

Engine Power Rating Information

The gross power rating for individual gas engine models is labeled in accordance with SAE (Society of Automotive Engineers) code J1940 (Small Engine Power & Torque Rating Procedure), and rating performance has been obtained and corrected in accordance with SAE J1995 (Revision 2002-05). Torque values are derived at 3060 RPM; horsepower values are derived at 3600 RPM. Actual gross engine power will be lower and is affected by, among other things, ambient operating conditions and engine-to-engine variability. Given both the wide array of products on which engines are placed and the variety of environmental issues applicable to operating the equipment, the gas engine will not develop the rated gross power when used in a given piece of power equipment (actual "on-site" or net power). This difference is due to a variety of factors including, but not limited to, accessories (air cleaner, exhaust, charging, cooling, carburetor, fuel pump, etc.), application limitations, ambient operating conditions (temperature, humidity, altitude), and engine-to-engine variability. Due to manufacturing and capacity limitations, Briggs & Stratton may substitute an engine of higher rated power for this Series engine.

TRACTOR - MODEL NO. TC 130 (96051012300), PRODUCT NO. 960 51 01-23
STEERING ASSEMBLY 41

KEY NO.	PART NO.	DESCRIPTION
1	532 43 99-97	Wheel, Steering
2	532 41 81-68	Axle Asm., Front
4	532 41 68-45	Spindle Asm., LH
5	532 41 68-46	Spindle Asm., RH
6	532 12 49-31	Bearing, Race Thrust Hardened
7	532 12 17-48	Washer 25/32 x 1-5/8 x 16 Ga.
8	812 00 00-29	Ring, Klip #T5304-75
9	532 12 12-32	Cap, Spindle
13	532 12 17-49	Washer, 25/32 x 1-1/4 x 16 Ga.
14	810 04 06-00	Washer, Lock Hvy Hlcl Spr 3/8
15	873 54 06-00	Nut, Crown Lock 3/8-24 unf
16	585 86 92-02	Steering Shaft
19	532 19 47-29	Plate Steering
20	532 44 14-25	Boot, Steering
21	532 18 67-37	Adapter, Wheel Steering
22	585 02 98-02	Bearing
26	532 43 97-43	Insert, Wheel Steering
27	819 21 16-16	Washer 21 x 32 x 1 x 16 Ga.
28	817 00 06-12	Screw 3/8-16 x 3/4
33	810 04 05-00	Washer Lock 5/16
35	532 19 47-32	Gear, Sector Plate
45	819 11 38-12	Washer 11/32 x 3/8 x 12 Ga.
53	532 18 89-67	Washer Hardened .793 x 1.637 x .060
57	532 40 74-65	Bracket Upstop
58	532 19 47-47	Bolt Shoulder Sector Pivot CFM
59	532 19 47-48	Washer Thrust Sector Steering
60	873 97 10-00	Nut Flange Lock 5/8-11
61	532 19 47-40	Draglink, LH
62	532 19 47-41	Draglink, RH
63	817 00 05-12	Screw 5/16-18 x 3/4
64	532 19 98-49	Retainer Clip Spring Steering
66	871 02 07-48	Bolt Hex Fghd 7/16-14 x 3 Serr
67	532 19 47-37	Bushing PM Front Axle
68	873 90 07-00	Nut Lock Flange 7/16-14 Gr. 5
69	532 19 91-62	Washer 1.5 x .505 x .118
70	532 41 70-65	Bracket Deck Susp. Front
71	532 19 07-52	Shaft Extension Steering
72	532 42 89-82	Bolt Fin Hex 5/16-18 x 4 w/Patch
74	532 12 49-37	Bearing
75	580 68 37-01	Pinion
76	580 68 36-01	Screw Head Sock
119	532 17 01-65	Bolt Shoulder 5/16-18
122	532 44 49-62	Cap Gear Sector

NOTE: All component dimensions given in U.S. inches
1 inch = 25.4 mm

TRACTOR - MODEL NO. TC 130 (96051012300), PRODUCT NO. 960 51 01-23
MOWER DECK 44

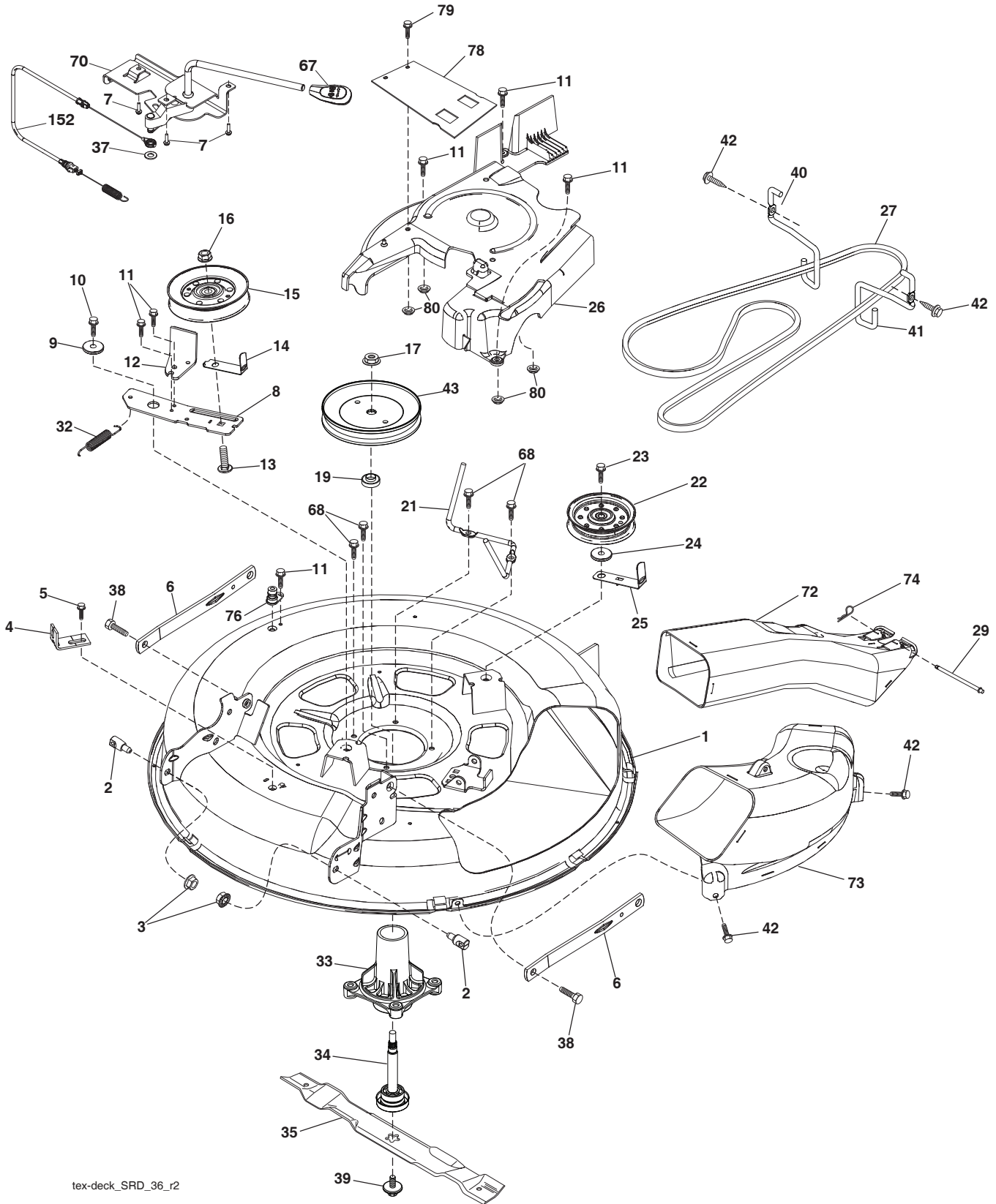

tex-deck_SRD_36_r2

TRACTOR - MODEL NO. TC 130 (96051012300), PRODUCT NO. 960 51 01-23
MOWER DECK 44

KEY NO.	PART NO.	DESCRIPTION	KEY NO.	PART NO.	DESCRIPTION
1	532 44 20-48	Deck Weldment 30"Srd	37	819 13 13-16	Washer 13/32 x 13/16 x 16 Ga.
2	532 19 51-61	Stud Fastner W/'D'anti-Rotatio	38	532 19 65-39	Bolt Shoulder
3	873 90 05-00	Nut Lock Hex Flange 5/16 - 18	39	584 30 93-01	Screw 7/16-20 x 1 Hex
4	532 41 76-45	Bracket Clutch Cable	40	532 41 92-70	Keeper Belt Engine LH
5	817 00 05-10	Bolt 5/16-18	41	532 41 92-65	Keeper Belt Engine RH
6	532 41 88-63	Arm Susp Mower Rear Srd	42	817 00 06-12	Screw Hexwsh THDR 3/8-16x3/4 BL
7	532 41 63-58	Screw #10 x 0.750 BOS Thd.	43	532 41 68-77	Pulley Mandrel 6 5 Pd 30"
8	532 42 02-52	Arm Idler 30"Srd	67	532 40 30-12	Handle Clutch Cable
9	532 19 90-92	Spacer Retainer	68	584 95 39-01	Bolt Hex Wsh Hd .313-18 x 1.19
10	817 00 06-16	Screw 3/8 - 16 X 1 Smgml Tap/R Blk	70	532 40 12-46	Clutch Asm. Manual
11	532 13 77-29	Screw Thd Roll 1/4 - 20 X 5/8	72	532 41 72-36	Chute Upper SRD 30R
12	532 19 94-70	Arm Brake Mower	73	532 42 52-74	Chute Lower SRD 30R
13	872 11 06-12	Bolt Carr Sh 3/8 - 16 X 1 - 1/2 Gr. 5	74	532 12 46-70	Retainer Spring
14	532 15 60-85	Keeper Belt Idler	76	532 41 55-98	Washout Port
15	532 14 67-63	Pulley Idler V-Groove Dim 4.25	78	532 42 25-66	Deck Guard
16	873 90 06-00	Nut Lock FIG 3/8 - 16 unc	79	532 14 24-32	Screw 1/4 x 1/2 unc
17	532 40 02-34	Nut Flange Lock Top	80	532 42 30-62	Palnut 1/4"
19	585 32 39-01	Bearing Mandrel	152	532 43 51-11	Cable Clutch w/Spring
21	532 41 69-10	Belt Keeper Mandrel	--	587 25 33-01	Mandrel Assembly (Includes Housing (key#14), Shaft Assembly (key#13), and Bearing Only (key#15) - Pulley/Nut/Washer and Blade Bolt/Washers Not Included)
22	532 17 58-20	Pulley Idler Flat	--	532 44 09-58	Replacement Mower Complete
23	817 49 06-28	Screw Thdrol 3/8 - 16 X 1-3/4			
24	819 13 20-12	Washer 13/32 X 1 - 1/4 X 12 Ga			
25	532 42 02-53	Keeper Belt 30"Srd			
26	532 42 02-55	Cover Mandrel Asm.			
27	532 41 92-71	V-Belt Drive			
29	532 42 08-95	Hinge Pin			
32	532 40 18-72	Spring Mower Drive			
33	532 18 72-81	Housing Mandrel 4pt Service			
34	587 25 65-01	Shaft Asm Mndrl N/Greaseable 38			
35	532 41 92-74	Blade			

NOTE: All component dimensions given in U.S. inches
1 inch = 25.4 mm

TRACTOR - MODEL NO. TC 130 (96051012300), PRODUCT NO. 960 51 01-23
MOWER LIFT 45

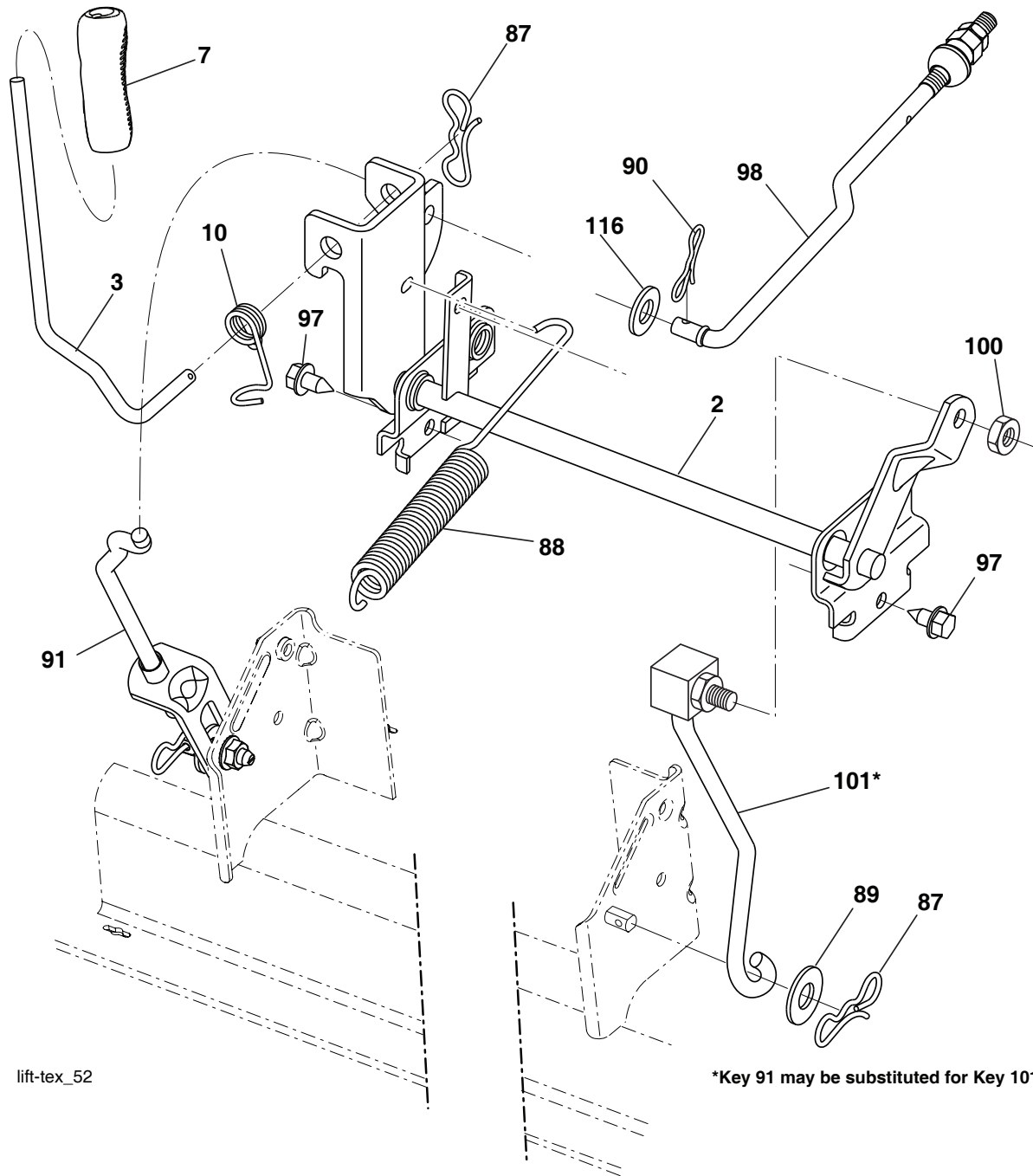

lift-tex_52

*Key 91 may be substituted for Key 101

KEY NO.	PART NO.	DESCRIPTION
2	532 42 20-27	Shaft Asm., Lift
3	532 19 52-31	Lever Asm., Lift RH
7	580 96 23-01	Grip, Lever
10	532 19 63-14	Spring Torsion
87	532 19 42-09	Pin Cotter 7/16 Bow Tie Lock
88	532 41 07-10	Spring Lift Assist
89	819 19 19-12	Washer Clear
90	532 19 42-08	Pin Cotter 5/16 Bow Tie Lock

KEY NO.	PART NO.	DESCRIPTION
91	532 19 51-81	Link Lift Susp Mower Rear
97	817 00 06-12	Screw 3/8-16 x 3/4
98	532 19 52-64	Link Lift Susp. Front Mower
100	873 93 06-00	Nut Centerlock 3/8-16 unc
101	532 40 70-03	Link Asm. Lift
116	819 15 15-16	Washer 15/32 x 15/16 x 16 Ga.

NOTE: All component dimensions given in U.S. inches
 1 inch = 25.4 mm

**TRACTOR - MODEL NO. TC 130 (96051012300), PRODUCT NO. 960 51 01-23
SEAT ASSEMBLY 42**

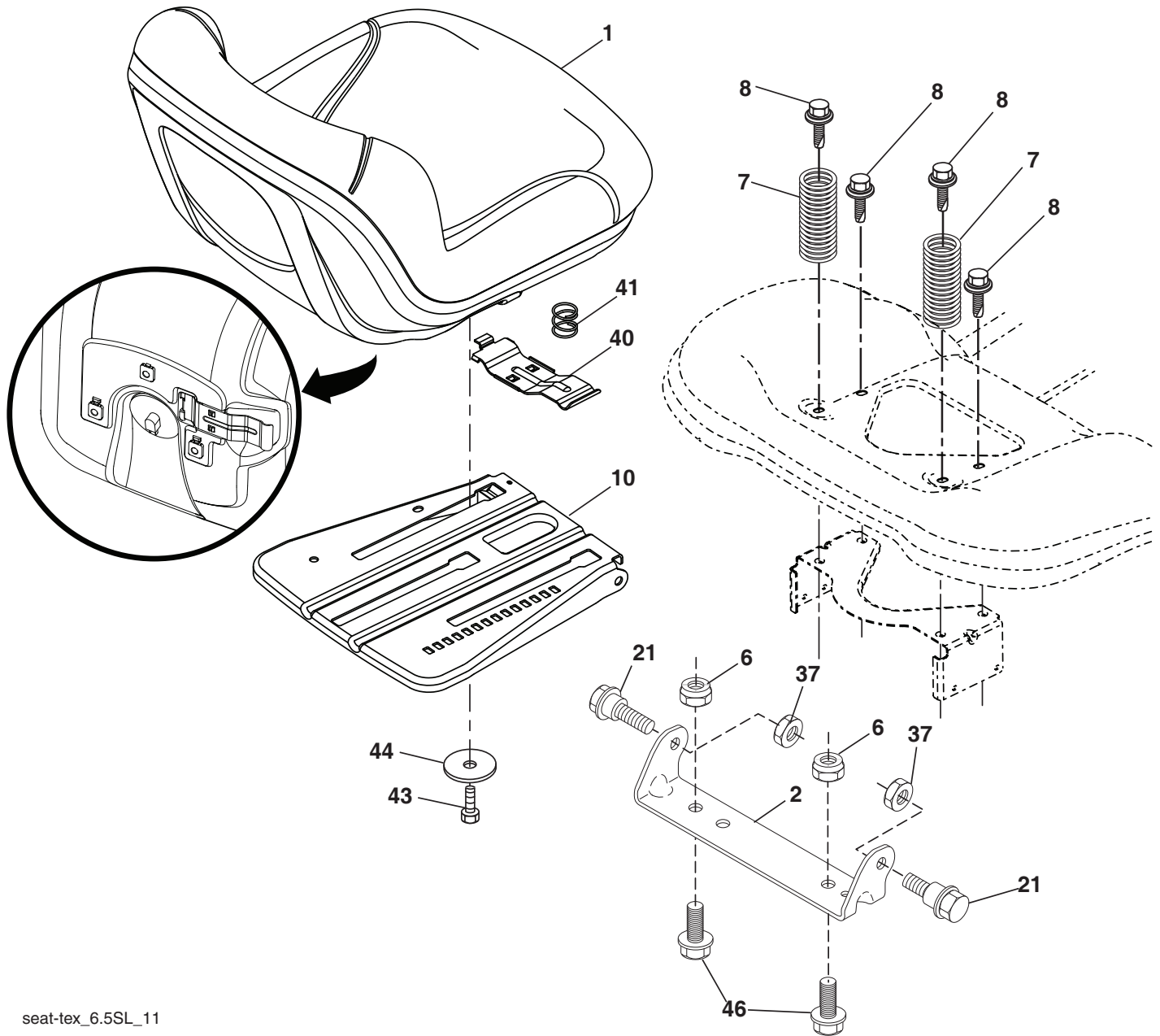

seat-tex_6.5SL_11

KEY NO.	PART NO.	DESCRIPTION
1	532 43 97-09	Seat
2	532 18 01-66	Bracket Pivot Fender
6	873 80 06-00	Nut, Lock w/Ins. 3/8-16 unc
7	587 61 33-01	Spring, Seat Cprsn
8	532 17 18-77	Bolt 5/16-18 unc x 3/4 w/Sems
10	532 19 69-77	Pan, Seat
21	587 90 78-01	Bolt, Shoulder 5/16-18 x 5/8
37	873 80 05-00	Nut, Lock 5/16-18 unc

KEY NO.	PART NO.	DESCRIPTION
40	532 19 76-61	Handle Slide Seat
41	532 19 82-00	Spring Latch Seat
43	874 76 06-12	Bolt 3/8-16 x 3/4
44	819 13 38-12	Washer 13/32 x 2-3/8 x 12 Ga.
46	588 09 04-01	Bolt 3/8-16 x 1, 1.25 OD Wshr

NOTE: All component dimensions given in U.S. inches
1 inch = 25.4 mm

TRACTOR - MODEL NO. TC 130 (96051012300), PRODUCT NO. 960 51 01-23
BAGGER **46**

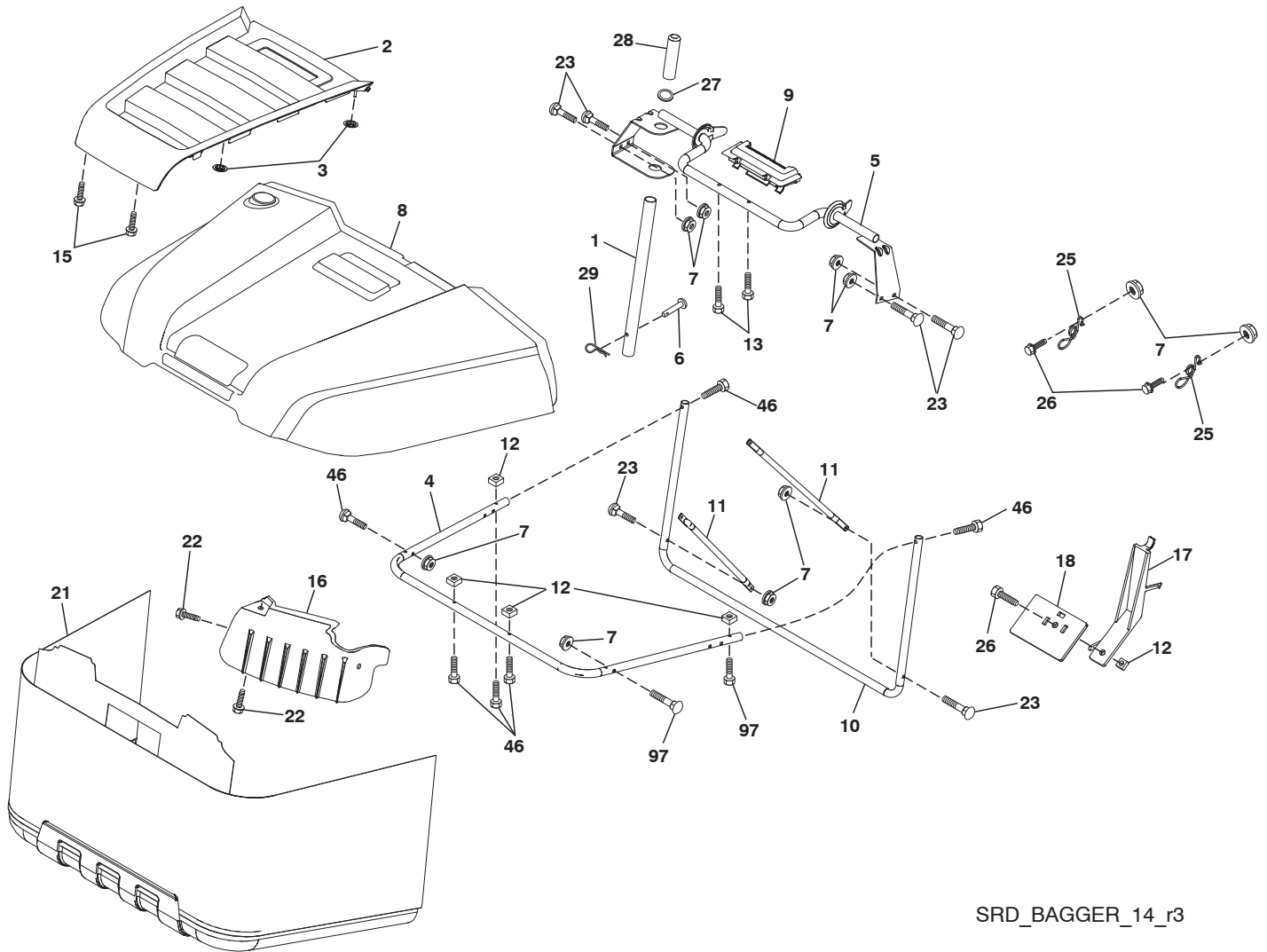

SRD_BAGGER_14_r3

**TRACTOR - MODEL NO. TC 130 (96051012300), PRODUCT NO. 960 51 01-23
BAGGER 46**

KEY NO.	PART NO.	DESCRIPTION
1	532 42 86-10	Tube Handle Bagger SRD
2	532 44 13-58	Applique
3	532 41 38-08	Nut Push
4	579 78 54-01	Frame Asm Bagger Top
5	532 41 76-32	Frame Asm Top Bagger SRD
6	532 12 68-75	Drilled Rivit
7	873 90 04-00	Nut Hex Flange 1/4-20 unc
8	532 44 12-61	Bagger Top
9	532 41 76-29	Insert Handle Bagger
10	532 41 71-90	Frame Front
11	532 41 71-88	Tubing Brace Bagger
12	532 42 17-93	Nut Square 1/4
13	532 42 17-80	Screw 1/4 x 1.150 HXWSH
15	532 42 18-01	Screw #8 Flat Head Drill Tip
16	532 42 15-66	Deflector Bagger
17	532 42 17-49	Lever Bagger Full
18	532 42 17-50	Paddle Bagger Full
21	532 42 99-81	Bag Asm SRD
22	532 14 24-32	Screw Hex WSH Hi-Lo 1/4 - 1/2 unc
23	872 04 04-10	Bolt Carr 1/4-20 unc x 1-1/4
25	532 42 16-14	Spring Latch Bagger
26	817 49 04-12	Screw Hex Thdrol 1/4-20 x 3/4
27	532 42 12-62	Grommet, Rubber SRD
28	532 16 57-87	Grip Handle Black
29	532 19 42-08	Pin Cotter 5/16 Bow Tie Lock
46	501 40 66-01	Screw Hx Cap 1/4-20 x 1.5
97	590 10 57-01	Screw Torx Butn HD 1/4-20-1.5"

NOTE: All component dimensions given in U.S. inches
1 inch = 25.4 mm

