

# ILLUSTRATED PARTS LIST

**MFG. ID NO. 96041038800**

**CUSTOMER CATALOG NO. TS 352**

**PRODUCT NO. 960 41 03-88**

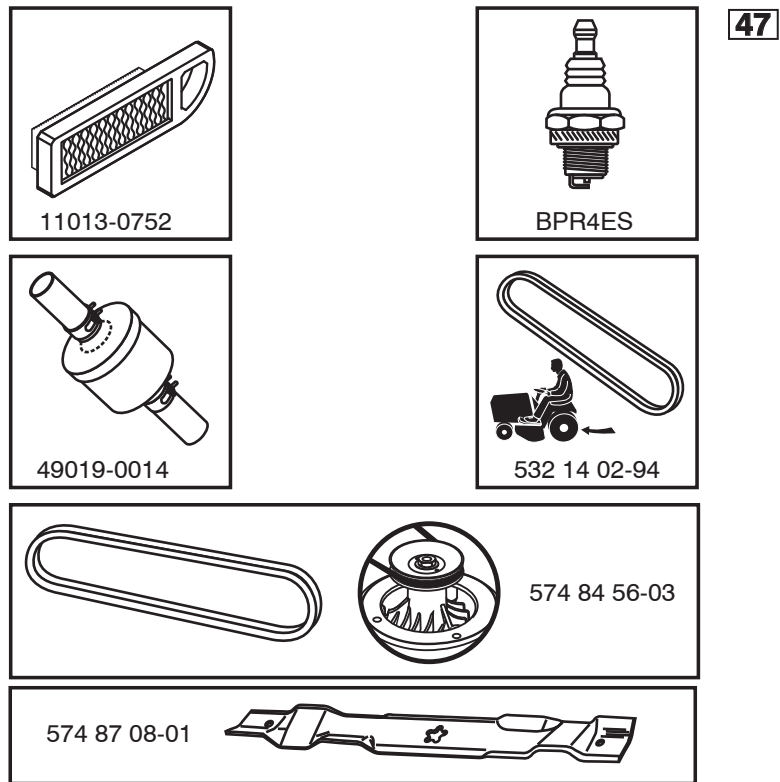

582485001

**TRACTOR - MODEL NO. TS 352 (96041038800), PRODUCT NO. 960 41 03-88  
DECALS**

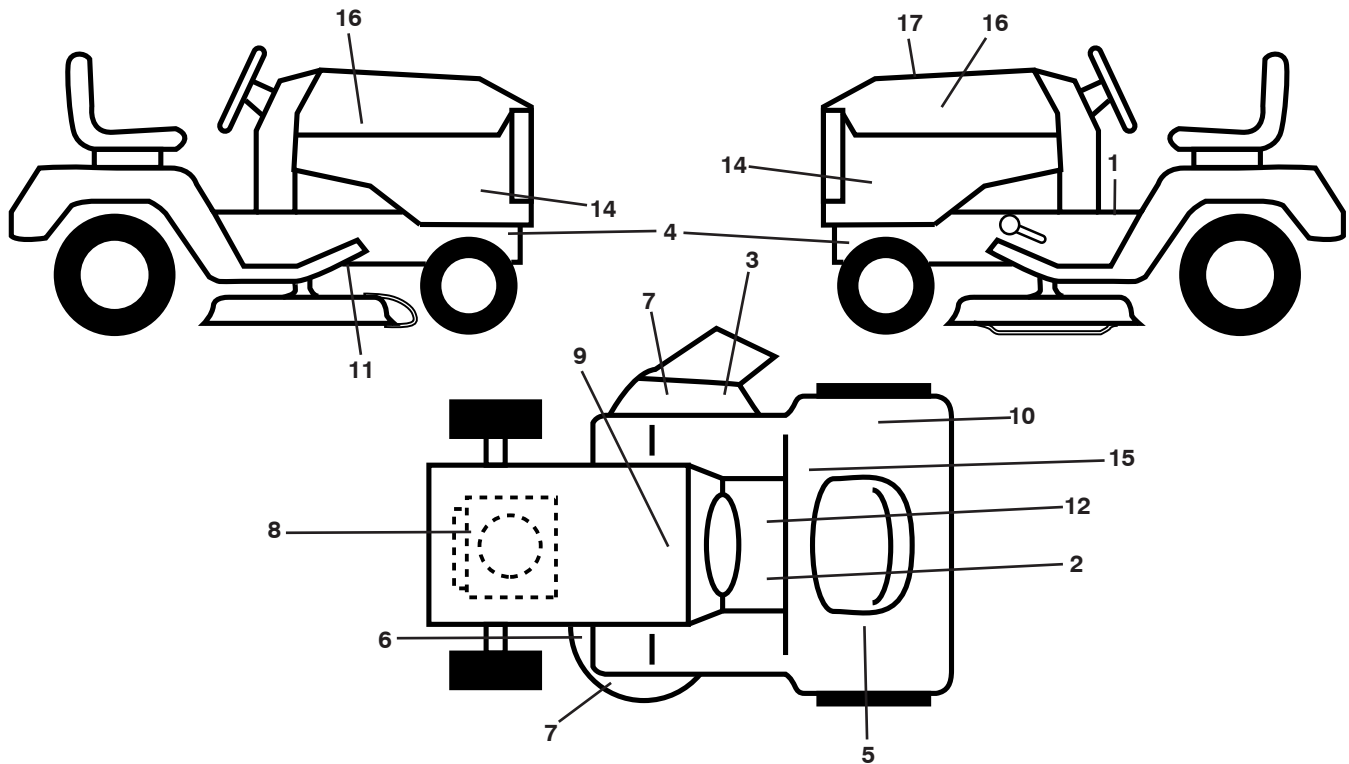

KEY NO.	PART NO.	DESCRIPTION
1	587 01 51-01	Decal, Reserve Fuel
2	586 80 03-01	Decal, Tractor Saddle
3	584 90 46-01	Decal, Deflect. Warning
4	581 57 96-01	Decal, Chassis Hot Muffler
5	581 57 80-01	Decal, Parking Brake
6	581 58 00-02	Decal, Mower Sch.
7	581 72 43-01	Decal, No Step
8	581 57 97-01	Decal, Engine
9	532 14 50-05	Decal, Battery Dnge/Poi
10	501 08 26-01	Decal, ECM Australia
11	532 41 86-00	Decal, Pedal Dealer

KEY NO.	PART NO.	DESCRIPTION
12	581 57 81-01	Decal, Read Own
14	588 77 48-01	Decal, Panel Side
15	581 72 40-01	Decal, Fender
16	581 62 73-01	Decal, Hood Logo
17	582 48 50-01	Decal, Replacement
--	581 72 48-01	Decal, Bypass
--	581 72 46-01	Decal, Drawbar
--	532 43 98-82	Pad, Footrest, LH
--	532 43 98-81	Pad, Footrest, RH
--	588 78 53-26	Manual, Operator (English)

**WHEELS AND TIRES**

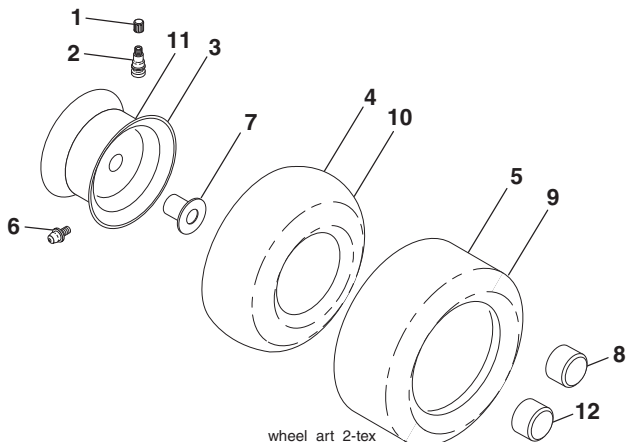

KEY NO.	PART NO.	DESCRIPTION
1	532 05 91-92	Cap, Valve, Tire
2	532 06 51-39	Stem, Valve
3	532 18 18-39	Rim Assembly, Front
4	532 00 81-34	Tube, Front (Service Item Only)
5	532 16 10-24	Tire, Front 16 x 6.5-8
6	532 12 49-57	Fitting, Grease (Front Wheel Only)
7	532 12 49-59	Bearing, Flange (Front Wheel Only)
8	532 17 50-39	Cap, Axle, Front
9	532 17 04-53	Tire, Rear 23 x 10.5-12
10	532 00 71-54	Tube, Rear (Service Item Only)
11	532 14 45-10	Rim Assembly, Rear
12	501 50 31-01	Cap, Hub, GT, PM, Black, Rear
--	532 14 43-34	Sealant, Tire (10 oz. Tube)

**NOTE:** All component dimensions given in U.S. inches  
1 inch = 25.4 mm

# TRACTOR - MODEL NO. TS 352 (96041038800), PRODUCT NO. 960 41 03-88 SCHEMATIC

SCH12

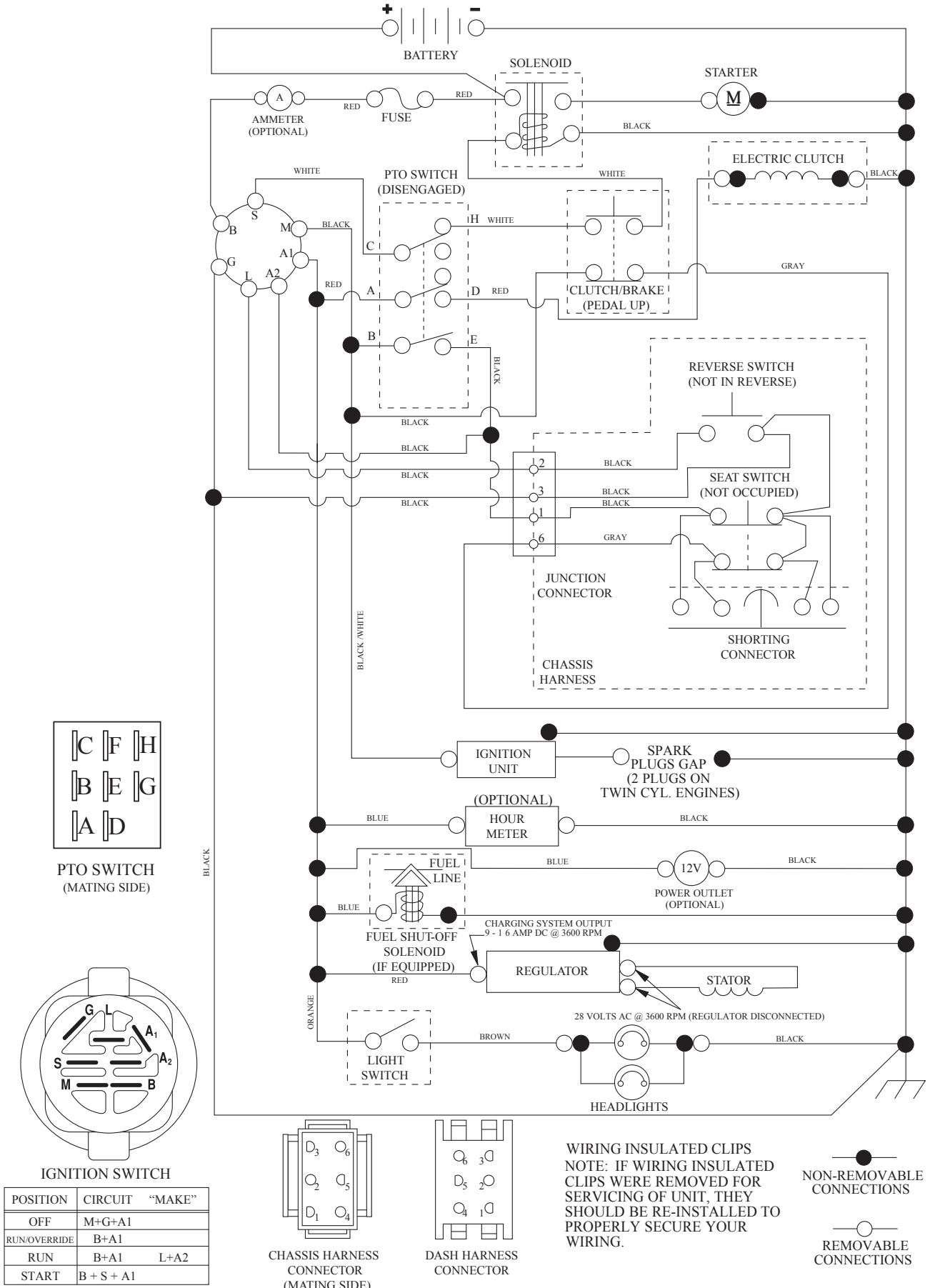

**TRACTOR - MODEL NO. TS 352 (96041038800), PRODUCT NO. 960 41 03-88  
ELECTRICAL**

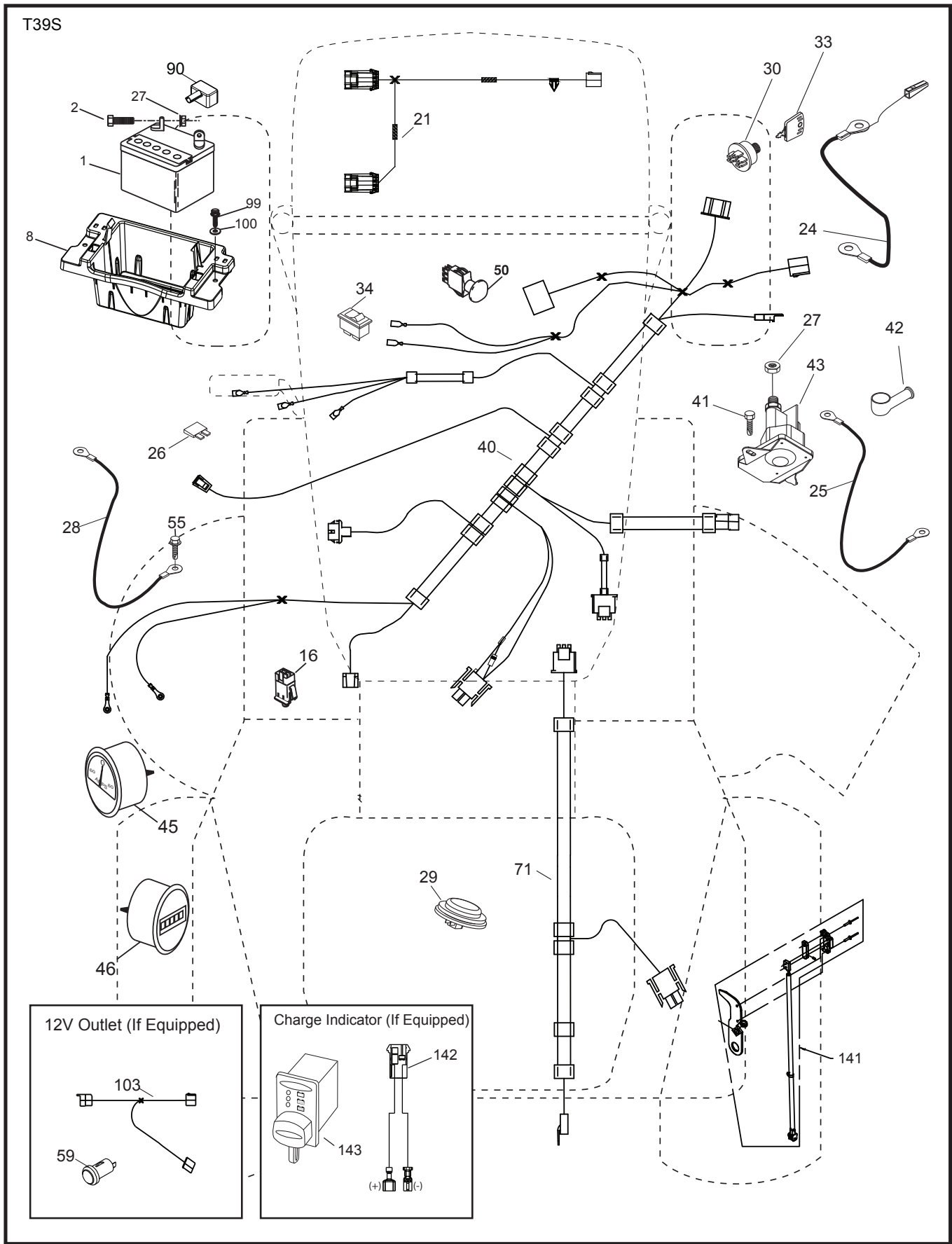

**TRACTOR - MODEL NO. TS 352 (96041038800), PRODUCT NO. 960 41 03-88  
ELECTRICAL**

<b>KEY NO.</b>	<b>PART NO.</b>	<b>DESCRIPTION</b>
1	532 16 34-65	Battery
2	874 76 04-12	Bolt Hex Hd 1/4-20 unc x 3/4
8	587 20 51-01	Battery Box
16	532 17 61-38	Switch Interlock
21	585 43 64-01	Harness Socket Light
24	585 55 56-01	Cable Battery
25	585 55 55-01	Cable Starter
26	532 17 51-58	Fuse
27	873 51 04-00	Nut Keps Hex 1/4-20 unc
28	532 41 65-88	Cable Ground 21" Blk 8 Ga.
29	532 40 15-45	Switch Seat
30	532 19 33-50	Switch Ign
33	532 41 19-35	Key/Chain
34	532 11 07-12	Switch Light/Reset
40	501 13 31-01	Harness Ign. Dash
41	817 72 04-08	Screw 1/4-20 unc x 1/2
42	532 13 15-63	Cover Terminal Red
43	582 04 28-01	Solenoid
45	587 55 39-03	Ammeter Round
46	587 55 40-03	Gauge Hourmeter
50	582 10 76-01	Switch PTO
55	817 06 05-12	Screw Thdrol 5/16-18 x 3/4
71	532 19 42-76	Harness Ign Chassis
90	532 43 53-95	Cover Terminal Battery
99	817 67 04-12	Screw Hexwsh Thdrol 1/4-20 x 3/4
100	819 09 14-16	Washer 9/32 x 7/8 x 16 Ga.
141	532 42 12-25	Kit G700/G730 ROS

**NOTE:** All component dimensions given in U.S. inches  
1 inch = 25.4 mm

# TRACTOR - MODEL NO. TS 352 (96041038800), PRODUCT NO. 960 41 03-88 CHASSIS

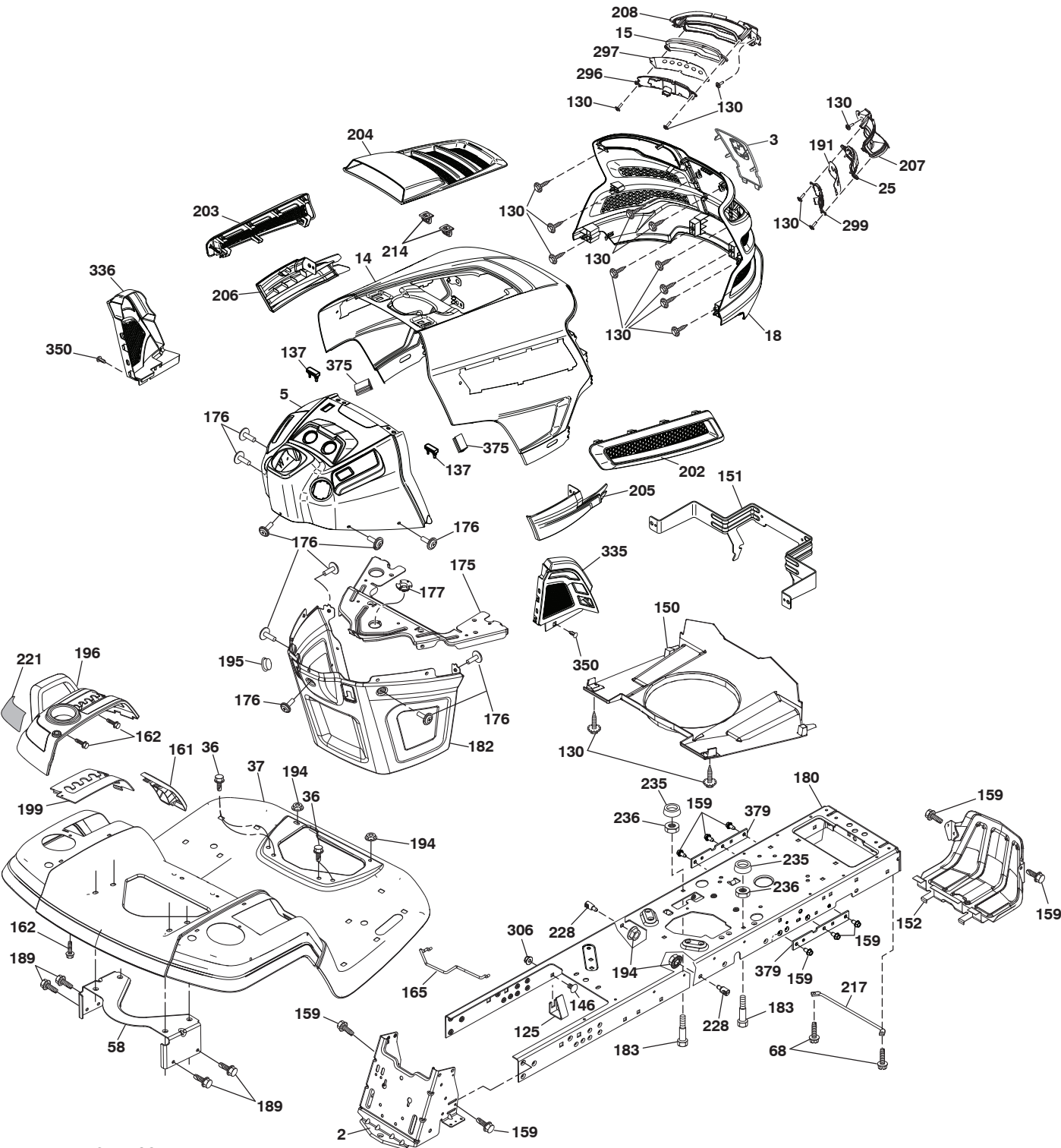

chassis-tex\_GT HUSQ II\_242

**TRACTOR - MODEL NO. TS 352 (96041038800), PRODUCT NO. 960 41 03-88  
CHASSIS**

KEY NO.	PART NO.	DESCRIPTION
2	580 43 44-01	Drawbar
3	532 44 44-81	Applique
5	582 09 11-01	Dash
14	532 44 11-77	Hood
15	585 42 03-01	Lens LH
18	587 52 34-01	Grille Asm
25	585 42 02-01	Lens RH
36	817 06 05-12	Screw 5/16-18 x 3/4
37	532 44 12-08	Fender
58	532 19 43-14	Bracket Fender
68	817 49 05-08	Screw 5/16-18 x 1/2
125	581 68 48-01	Clip Fuel Line
130	532 41 63-58	Screw #10 x 0.750 BOS Thread
137	532 40 75-90	Bumper Dash
146	581 85 79-01	Bolt
150	532 43 97-74	Duct Air
151	532 43 66-70	Bracket Pivot Hood
152	532 43 98-70	Shield Browning/Debris
159	817 00 06-12	Screw 3/8-16 x 3/4
161	532 43 99-29	Console Fuel Window
162	532 14 24-32	Screw Hex Wsh Hi-Lo 1/4 x 1/2
165	532 19 43-30	Bracket Support Tank
175	532 19 63-04	Crossmember
176	532 40 07-76	Screw 10-24 x 5/8 Wshd Qdix
177	532 19 52-28	Bushing Steering
180	593 34 63-01	Chassis
182	532 40 68-59	Dash Lower
183	874 52 05-20	Bolt 5/16-18 x 1-1/4
189	817 00 05-12	Screw 5/16-18 x 3/4
191	586 18 28-01	Insert Reflective RH
194	873 90 05-00	Nut Lock Hex Flange 5/16-18

KEY NO.	PART NO.	DESCRIPTION
195	532 40 41-37	Plug
196	532 43 97-16	Console Asm. Deck Lift
199	532 19 82-59	Plate Deck Lift
202	532 43 97-28	Vent Side Hood RH
203	532 43 97-27	Vent Side Hood LH
204	532 44 44-84	Vent Asm Hood Top
205	532 43 97-30	Trim Hood Side RH
206	532 43 97-29	Trim Hood Side LH
207	585 42 00-02	Bezel RH
208	585 42 01-02	Bezel LH
214	532 19 91-45	Clip Retainer
217	532 40 91-67	Rod Pivot
221	532 19 89-09	Reflector LH
228	532 19 51-61	Stud Fastener
235	532 40 61-29	Spacer Fender
236	873 93 05-00	Nut Center Lock 5/16-18 unc
296	585 42 05-01	LED Light LH
297	586 18 29-01	Insert Reflective LH
299	585 42 04-01	LED Light RH
306	873 90 06-00	Nut Lock
335	532 44 82-04	Cover RH
336	532 44 53-09	Cover LH
350	532 44 51-43	Clip X-mas Tree
375	586 90 82-01	Dash Clip-On Bumper
379	593 20 69-02	Chassis Plate Reinforcement
--	532 43 18-82	Kit Guard Brush

**NOTE:** All component dimensions given in U.S. inches  
1 inch = 25.4 mm

TRACTOR - MODEL NO. TS 352 (96041038800), PRODUCT NO. 960 41 03-88  
DRIVE

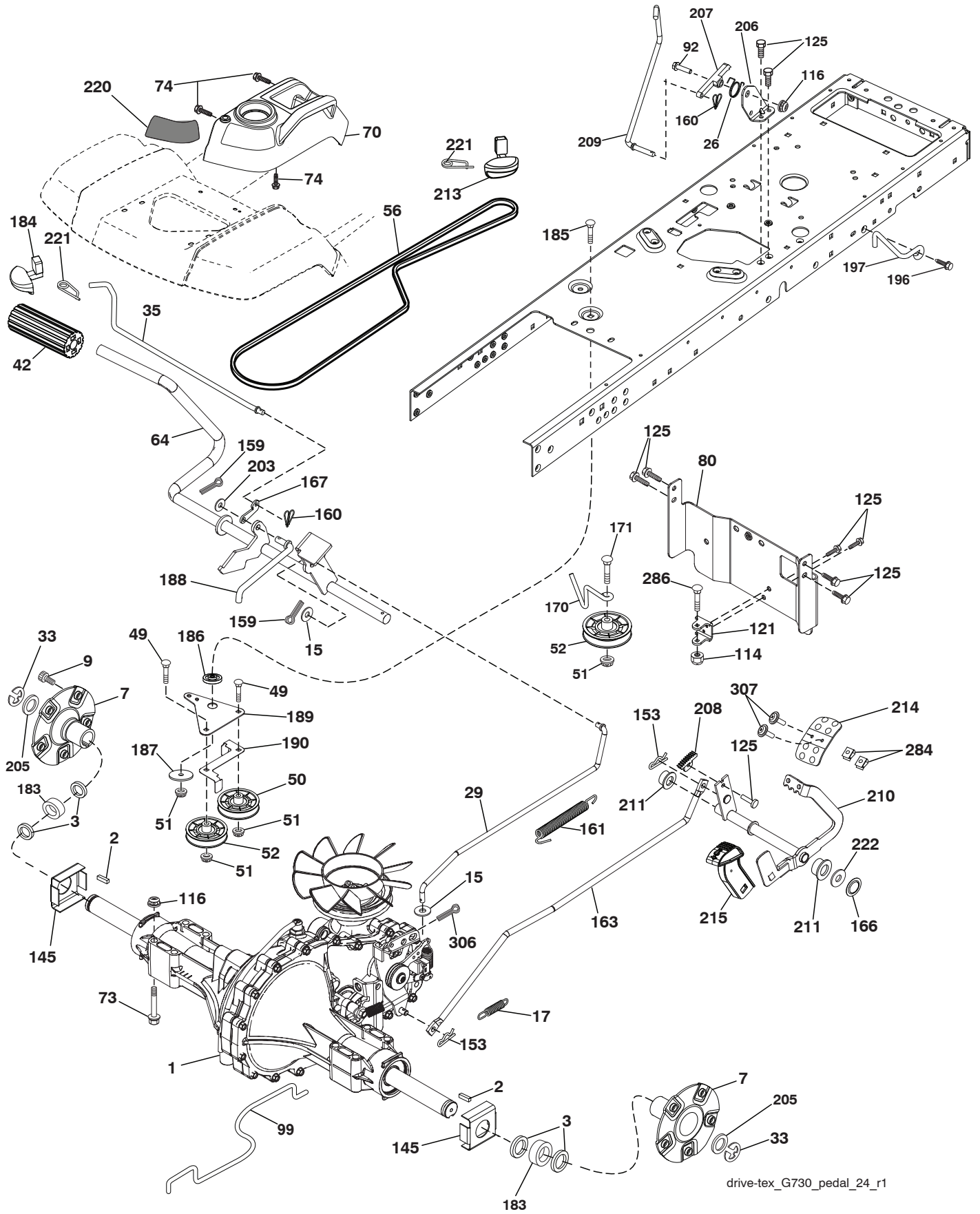

drive-tex\_G730\_pedal\_24\_r1



**TRACTOR - MODEL NO. TS 352 (96041038800), PRODUCT NO. 960 41 03-88  
DRIVE**

KEY NO.	PART NO.	DESCRIPTION	KEY NO.	PART NO.	DESCRIPTION
1	---	Transaxle, Hydro G7-BCBB-1XDC-1FCA (420331) (Order parts from transaxle manufacturer.)	166	532 42 91-64	Nut Push .625
2	539 91 27-57	Key .25 x 1.25	167	532 40 52-57	Latch Brake Parking
3	532 00 75-63	Washer Thrust Axle Hardened	170	532 19 43-22	Idler V-Groove 910" Offset
7	586 93 54-02	Hub Asm. Wheel	171	872 11 06-16	Bolt RDHD SQNK 3/8-16 unc x 2
9	532 14 00-80	Bolt Hub Wheel	183	501 05 15-01	Spacer Split
15	819 13 13-16	Washer 13/32 x 13/16 x 16 Ga.	184	587 65 37-01	Handle Parking Brake
17	532 19 72-96	Spring, Brake	185	872 11 06-22	Bolt RDHD 3/8-16 unc x 2-3/4 Gr.5
26	532 19 96-79	Spring Return Cruise	186	532 19 43-21	Spacer Retainer
29	532 41 81-86	Rod, Brake	187	819 13 32-10	Washer
33	812 00 00-53	Ring E	188	582 21 70-01	Link Clutch Ground Drive Long
35	583 86 45-01	Rod, Brake, Park	189	532 19 43-17	Bellcrank Ground Drive
42	532 12 48-72	Cover, Foot Pedal	190	532 19 43-18	Keeper Bellcrank Ground Drive
49	872 11 06-14	Bolt	196	817 00 06-16	Screw 3/8-16 x 1
50	532 19 43-27	Pulley Idler Flat	197	585 65 86-01	Bracket Clutch Anti-Rotation
51	873 90 06-00	Lock Nut 3/8-16	203	819 11 11-16	Washer 11/32 x 11/16 x 16 Ga.
52	532 19 43-26	Idler V-Groove	205	532 12 38-00	Washer 1-1/32 x 1-5/8 x 16 Ga.
56	532 14 02-94	V-Belt	206	532 44 85-96	Bracket Mount Latch Cruise
64	532 19 78-65	Shaft Asm. Pedal Brake Control	207	587 03 14-01	Latch Control Cruise
70	532 43 96-61	Console Asm	208	532 19 78-69	Gear Sector Control Cruise
73	874 49 05-48	Bolt Hex 5/16-18 x 3 Gr. 5	209	532 19 95-92	Rod Control Cruise
74	532 14 24-32	Screw 1/4 x 1/2	210	532 19 78-60	Rocker Asm. Pedal Control
80	532 41 81-84	Strap Torque	211	532 12 01-83	Bearing Nylon
92	874 76 05-20	Bolt 5/16-18 x 1/2	213	532 40 31-19	Knob Control Cruise
99	532 41 81-88	Spring Bypass	214	532 41 68-63	Pedal Forward
114	873 80 05-00	Nut Lock Hex W/Ins. 5/16-18 unc	215	586 60 65-02	Pedal Reverse
116	873 90 05-00	Nut Lock Hex Flange 5/16-18	220	532 19 89-08	Reflector RH
121	532 17 56-11	Bracket Strap Torque	221	532 40 31-87	Retainer Spring Clip Handle
125	817 00 05-12	Screw 5/16-18 x 3/4	222	879 21 20-10	Washer 21/32 x 1-1/4 x 10 Ga.
145	532 16 31-68	Washer Axle Flange	284	532 41 76-93	Nut U-Chnl. 1/4-20
153	532 12 47-88	Retainer Spring	286	872 01 05-20	Bolt 5/16-18 x 2.50
159	876 02 04-12	Pin Cotter 1/8 x 3/4	306	876 02 04-16	Pin Cotter 1/8 x 1
160	532 16 94-84	Retainer Clip	307	874 18 04-12	Screw Mach 1/4-20 x 3/4
161	532 10 57-09	Spring, Return, Clutch			
163	532 41 81-85	Rod Pedal Control			

**NOTE:** All component dimensions given in U.S. inches  
1 inch = 25.4 mm

**TRACTOR - MODEL NO. TS 352 (96041038800), PRODUCT NO. 960 41 03-88  
ENGINE**

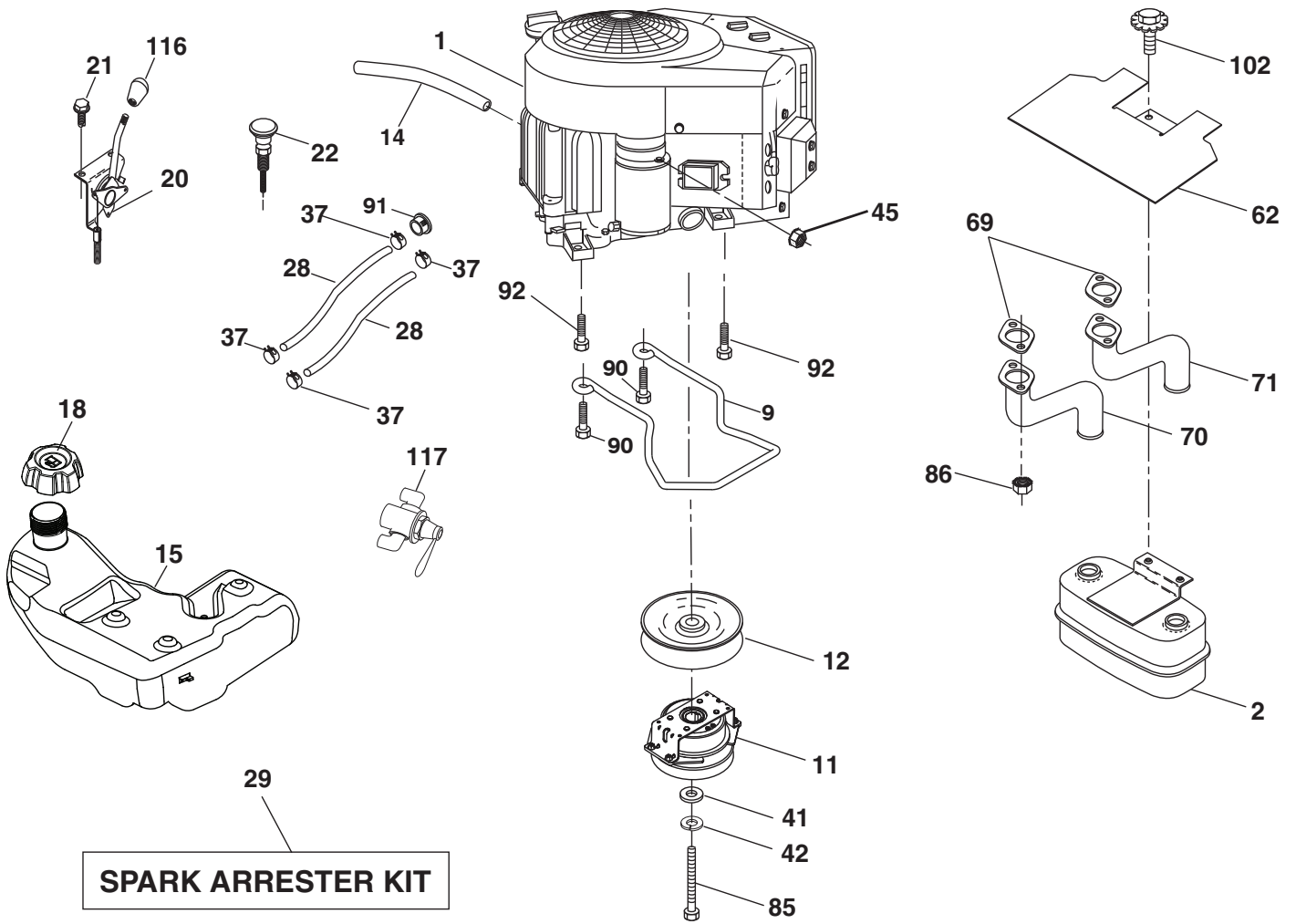

engine-tex\_Kawa-2cyl\_45\_r2

**TRACTOR - MODEL NO. TS 352 (96041038800), PRODUCT NO. 960 41 03-88  
ENGINE**

<b>KEY NO.</b>	<b>PART NO.</b>	<b>DESCRIPTION</b>
1	-----	Engine KAWA Model No. FR730V-DS04 (445363)(Order parts from engine manufacturer.)
2	589 81 87-01	Muffler
9	501 83 26-02	Keeper Asm. Belt Engine
11	587 24 14-01	Clutch Electric
12	532 19 43-43	Pulley Engine
14	532 14 84-56	Tube Drain Oil Easy
15	532 42 28-04	Tank Fuel
18	584 24 87-02	Cap Asm
20	532 42 43-41	Control Throttle
21	532 41 63-58	Screw #10 x 0.750 BOS Thread
22	532 18 95-41	Control Choke
28	587 04 46-61	Fuel Line
29	532 13 71-80	Spark Arrester Kit
37	532 12 34-87	Clamp Hose
41	532 12 61-97	Washer 1-1/2 OD x 15/32 ID x .250
42	539 99 02-47	Washer 7/16
45	873 51 04-00	Nut Keps Hex 1/4-20 unc
62	532 43 40-17	Shield Heat Muffler
69	532 17 81-51	Gasket
70	583 95 56-01	Tube Exhaust LH
71	583 95 57-01	Tube Exhaust RH
85	501 60 69-01	Bolt 7/16-20 x 3.0 Gr. 5 Yellow
86	532 18 43-62	Nut Hex Flange Toplock M8-1.25
90	817 00 06-16	Screw 3/8-16 x 1
91	532 18 74-95	Bushing
92	817 06 06-20	Screw 3/8-16 x 1-1/4
102	817 00 05-12	Screw 5/16-18 x 3/4
116	539 13 26-24	Knob Soft Touch
117	532 42 08-28	Valve Fuel Reserve

**NOTE:** All component dimensions given in U.S. inches  
1 inch = 25.4 mm

For engine service and replacement parts, call the toll free number for your engine manufacturer listed below:

Kawasaki 1-949-460-5688



**TRACTOR - MODEL NO. TS 352 (96041038800), PRODUCT NO. 960 41 03-88  
STEERING ASSEMBLY**

<b>KEY NO.</b>	<b>PART NO.</b>	<b>DESCRIPTION</b>
1	532 43 97-40	Wheel, Steering
2	532 41 35-91	Axle Asm., Front
4	532 40 30-89	Spindle Asm., LH
5	532 40 30-90	Spindle Asm., RH
6	532 12 49-31	Bearing, Race Thrust Harden
7	532 12 17-48	Washer 25/32 x 1-5/8 x 16 Ga.
8	812 00 00-29	Ring, Klip #T5304-75
9	532 12 12-32	Cap, Spindle
13	532 12 17-49	Washer 25/32 x 1-1/4 x 16 Ga.
14	539 99 01-18	Washer 3/8
15	873 54 06-00	Nut, Crown Lock 3/8-24 unf
16	587 01 60-02	Shaft Steering
19	532 19 47-29	Plate Steering
21	586 84 02-01	Adapter, Wheel Steering
22	585 02 99-01	Steering Support Lower
26	532 43 97-43	Insert, Wheel Steering
27	819 21 16-16	Washer 21/32 x 1 x 16 Ga.
28	817 00 06-12	Screw 3/8-16 x 3/4
35	532 19 47-32	Gear, Sector Plate
45	587 01 64-01	Washer 3/8 ID x 2-3/8 OD 12 Ga.
50	873 90 06-00	Nut Lock Flg. 3/8-16
53	532 18 89-67	Washer Hardened .793 x 1.637 x .060
54	874 76 06-36	Bolt Hex 3/8-16 x 2-1/4
55	532 41 47-36	Spacer Axle Brace
58	532 19 47-47	Bolt Shoulder Sector Pivot CFM
59	532 19 47-48	Washer Thrust Sector Steering
60	873 97 10-00	Nut Flange Lock 5/8-11
61	588 79 44-02	Draglink LH
62	588 79 45-02	Draglink, RH
63	817 00 05-12	Screw 5/16-18 x 3/4
64	532 19 98-49	Retainer Clip Spring Steering
65	532 19 47-34	Brace Axle Front
66	871 02 07-48	Bolt Hex Fghd 7/16-14 x 3 Serr
67	532 19 47-37	Bushing Front Axle
68	873 90 07-00	Nut Lock Flange 7/16-14 Gr. 5
69	532 19 91-62	Washer 1.5 x .505 x .118
70	585 33 88-01	Bracket Deck Susp. Front
75	580 68 37-01	Pinion Steering Shaft
76	580 68 36-01	Screw Head Socket Flat
78	532 05 70-79	Washer Thrust
118	532 40 60-13	Bushing
122	532 44 49-62	Cap Gear Sector

**NOTE:** All component dimensions given in U.S. inches  
1 inch = 25.4 mm

TRACTOR - MODEL NO. TS 352 (96041038800), PRODUCT NO. 960 41 03-88  
MOWER DECK

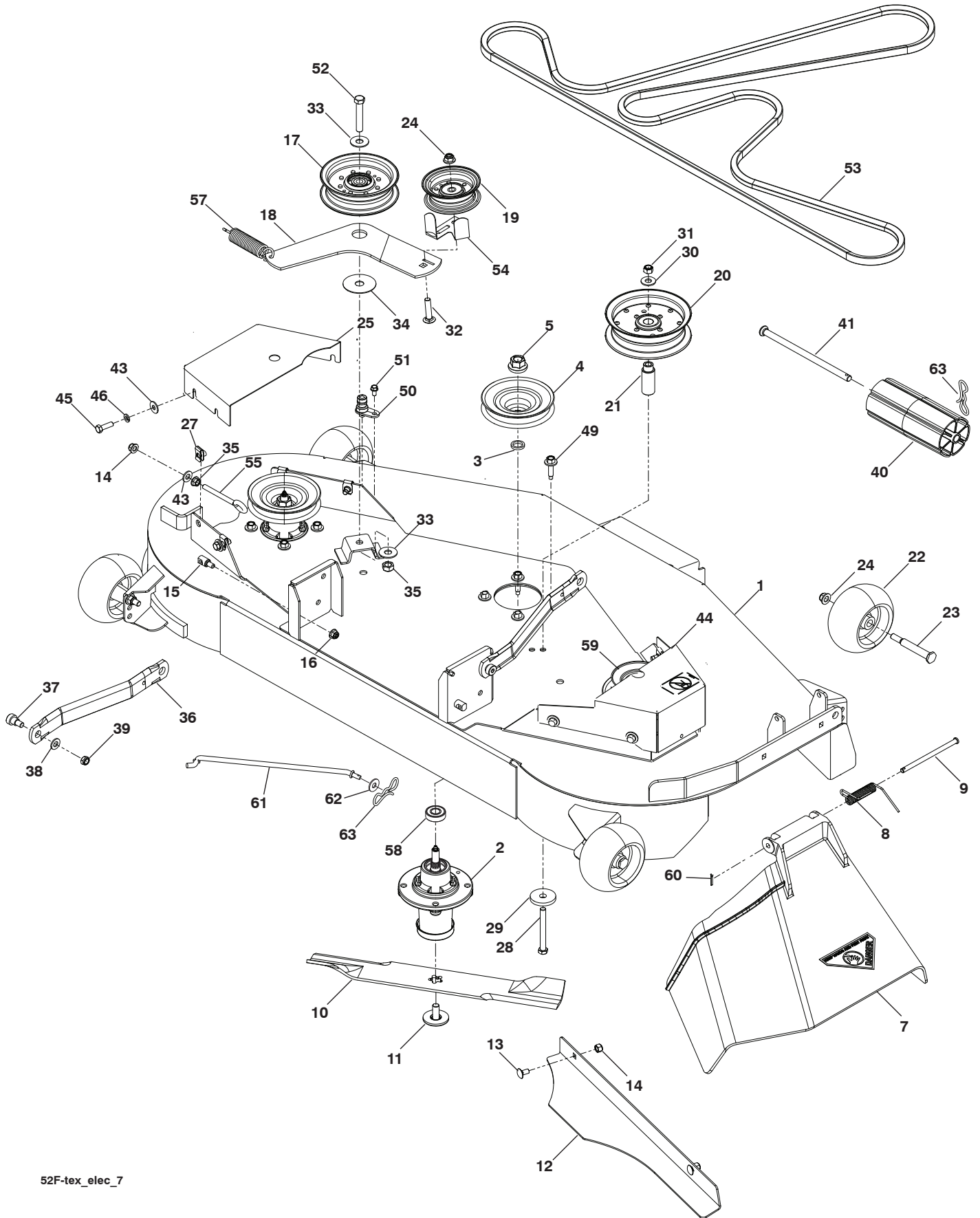

52F-tex\_elec\_7

**TRACTOR - MODEL NO. TS 352 (96041038800), PRODUCT NO. 960 41 03-88  
MOWER DECK**

KEY NO.	PART NO.	DESCRIPTION
1	574 80 44-05	Deck
2	539 11 21-70	Housing Assembly
3	539 18 76-90	Washer-Spacer
4	532 17 43-75	Pulley, Mandrel
5	539 40 02-34	Nut, 9/16 Top Center Lock
7	539 11 07-33	Discharge Chute, 52"
8	539 11 07-35	Spring - Torsion
9	539 11 07-36	Pin, Clevis 5/16 x 5.19
10	574 87 08-01	Blade, 16-1/4"
11	532 19 30-03	Bolt, 7/16, Assy Blade
12	592 96 79-02	Confinement Plate
13	872 11 05-05	Bolt Carr. 5/16-18 x 5/8 Short
14	873 80 05-00	Nut 5/16-18 Hex Nyloc
15	532 19 51-61	Stud, Fasten w/ Anti- Rotate
16	873 90 06-00	Nut Lock Flg. 7/16-14 Gr. 5
17	532 19 61-04	Pulley, Idler Spec. Hub
18	574 84 18-02	Arm, Idler, Blk
19	532 17 79-68	Pulley, Idler
20	539 13 27-28	Pulley, Idler
21	575 22 45-01	Idler Bushing
22	532 13 39-57	Wheel, Gauge
23	532 19 34-06	Bolt, Shoulder
24	521 99 65-01	Nut 3/8-16 Hex Flg Nyloc
25	575 22 47-06	Shield, Belt LH
27	539 10 47-63	Retainer 5/16c U Type
28	539 10 82-71	Hcs 3/8-16 x 3-1/2 Gr 5
29	539 10 65-04	Heavy Washer
30	819 14 16-14	Washer, 3/8 Flat Std
31	539 97 69-79	Nut 3/8-16 Hex Nyloc
32	539 99 09-23	Rhsnb 3/8-16 x 1-3/4 Gr 5
33	539 10 48-64	Washer, 7/16 Flat
34	532 17 85-15	Washer, Flat Hardened
35	873 90 07-00	Nut, 7/16-14
36	532 19 51-85	Arm, Susp., Rear

KEY NO.	PART NO.	DESCRIPTION
37	539 11 36-21	Sb 3/8-16 x 3/8 Skt Hd
38	819 13 13-16	Washer 13/32 x 13/16 x 16 Ga.
39	539 20 02-82	Nut, 3/8-16 Hex Jam Nyloc
40	532 17 60-66	Roller Nose
41	532 17 91-27	Rod Roller Nose
43	819 12 14-14	Washer 3/8 x 7/8 x 14 Ga.
44	575 96 73-04	Shield, Belt RH
45	874 78 05-16	Bolt 5/16-18 x 1 Gr 5
46	539 99 01-87	Washer 5/16 Slw
49	584 95 39-01	Bolt Hex Wsh Hd 313-18 x 1.19
50	532 41 55-98	Washout Port
51	817 49 04-08	Bolt 5/16-18 x 1
52	874 78 07-40	Bolt Hex 7/16-14 x 2-1/2
53	574 84 56-03	Belt, Deck
54	532 14 10-43	Guard, Belt
55	539 11 55-74	Eyebolt 5/16 x 3-1/2
57	539 10 68-50	Spring
58	532 11 04-85	Ball Bearing
59	575 35 29-01	Pulley
60	532 16 94-84	Clip Retainer
61	532 40 03-37	Rod Anti-Sway
62	819 13 13-12	Washer 13/32 x 13/16 x 12 Ga.
63	532 19 42-08	Pin Cotter 5/16 Bow Tie Lock
--	532 41 64-05	Coupling Quick Connect
--	588 78 15-01	Mower Deck Complete

**NOTE:** All component dimensions given in U.S. inches  
1 inch = 25.4 mm

**TRACTOR - MODEL NO. TS 352 (96041038800), PRODUCT NO. 960 41 03-88  
MOWER LIFT**

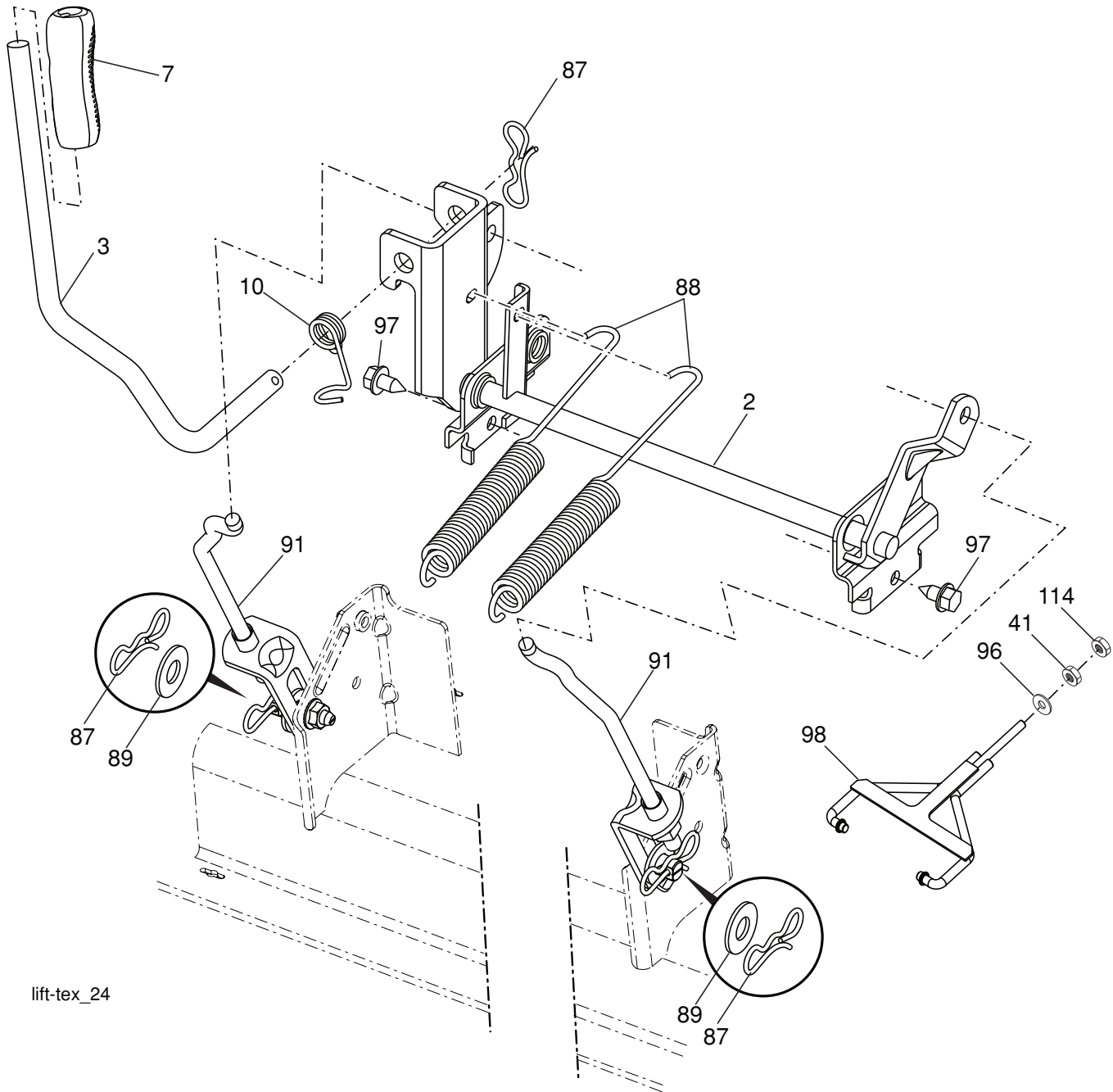

lift-tex\_24

KEY NO.	PART NO.	DESCRIPTION
2	532 42 20-27	Shaft Asm., Lift
3	532 19 52-30	Lever Asm., Lift RH
7	580 96 23-01	Grip, Lever
10	532 19 63-14	Spring Torsion
41	532 17 59-94	Nut Lift Link
87	532 19 42-09	Pin Cotter 7/16 Bow Tie Lock
88	532 19 53-04	Spring Lift Assist
89	819 19 19-12	Washer Clear Zinc

KEY NO.	PART NO.	DESCRIPTION
91	532 40 34-07	Link Lift Susp Mower Rear
96	532 19 52-63	Bushing Spherical
97	817 00 06-12	Screw 3/8-16 x .75
98	574 82 25-01	Link Lift Susp. Front Mower
114	873 36 07-00	Nut Jam 7/16-20

**NOTE:** All component dimensions given in U.S. inches  
1 inch = 25.4 mm



# TRACTOR - MODEL NO. TS 352 (96041038800), PRODUCT NO. 960 41 03-88 SEAT ASSEMBLY

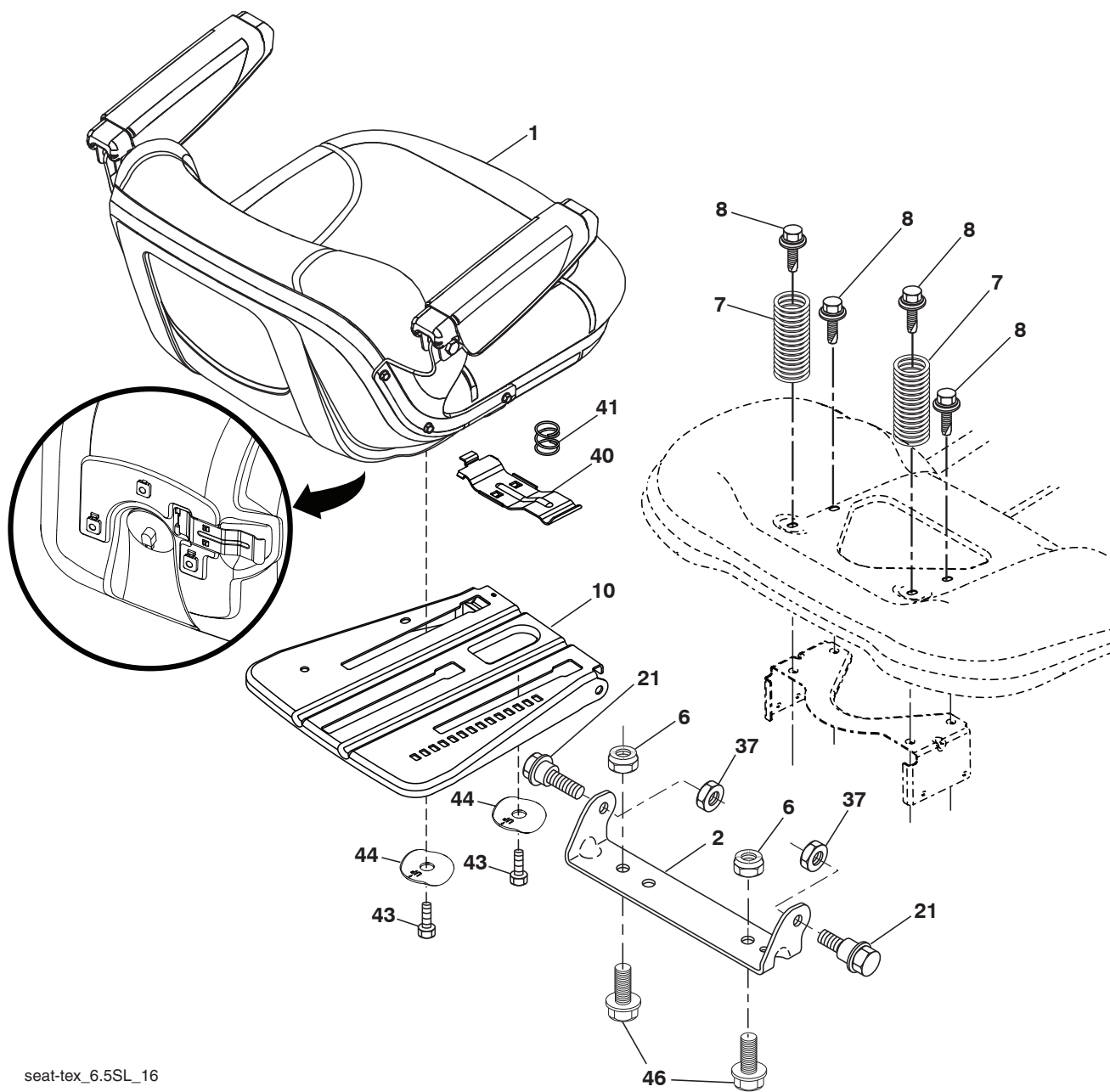

seat-tex\_6.5SL\_16

KEY NO.	PART NO.	DESCRIPTION
1	588 55 67-01	Seat
2	532 18 01-66	Bracket Pivot Fender
6	873 80 06-00	Nut, Lock w/Ins. 3/8-16 unc
7	589 48 35-01	Spring, Seat Cprsn
8	532 17 18-77	Bolt 5/16-18 unc x 3/4 w/Sems
10	587 23 20-02	Pan, Seat
21	587 90 78-01	Bolt, Shoulder 5/16-18 x 5/8
37	873 80 05-00	Nut, Lock 5/16-18 unc

KEY NO.	PART NO.	DESCRIPTION
40	532 43 98-71	Handle Slide Seat
41	532 19 82-00	Spring Latch Seat
43	874 76 06-12	Bolt Fin Hex 3/8-16 unc x 3/4
44	501 05 18-01	Washer Winged 3/8 ID 1.50 OD
46	588 09 04-01	Bolt 3/8-16 x 1, 1.25 OD Wshr

**NOTE:** All component dimensions given in U.S. inches  
1 inch = 25.4 mm

