

# ILLUSTRATED PARTS LIST

**MFG. ID NO. 96051014500**

**CUSTOMER CATALOG NO. TC 139T**

**PRODUCT NO. 960 51 01-45**

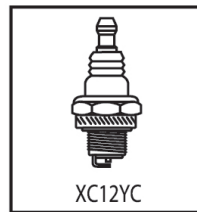
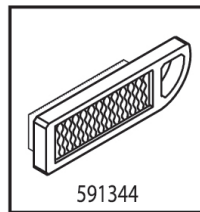

**47**

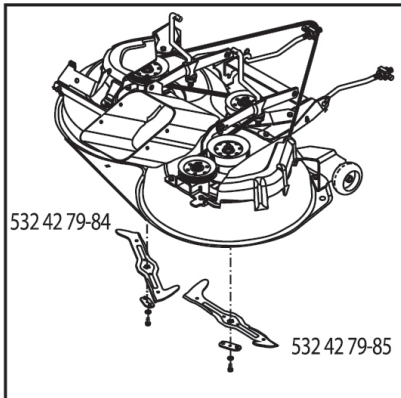
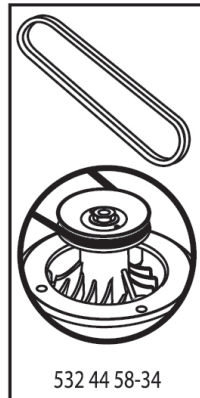
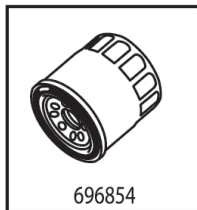
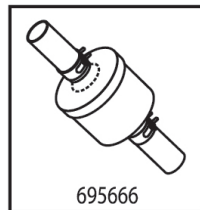

**589413801**

**TRACTOR - MODEL NO. TC 139T (96051014500), PRODUCT NO. 960 51 01-45**  
**DECALS 27**

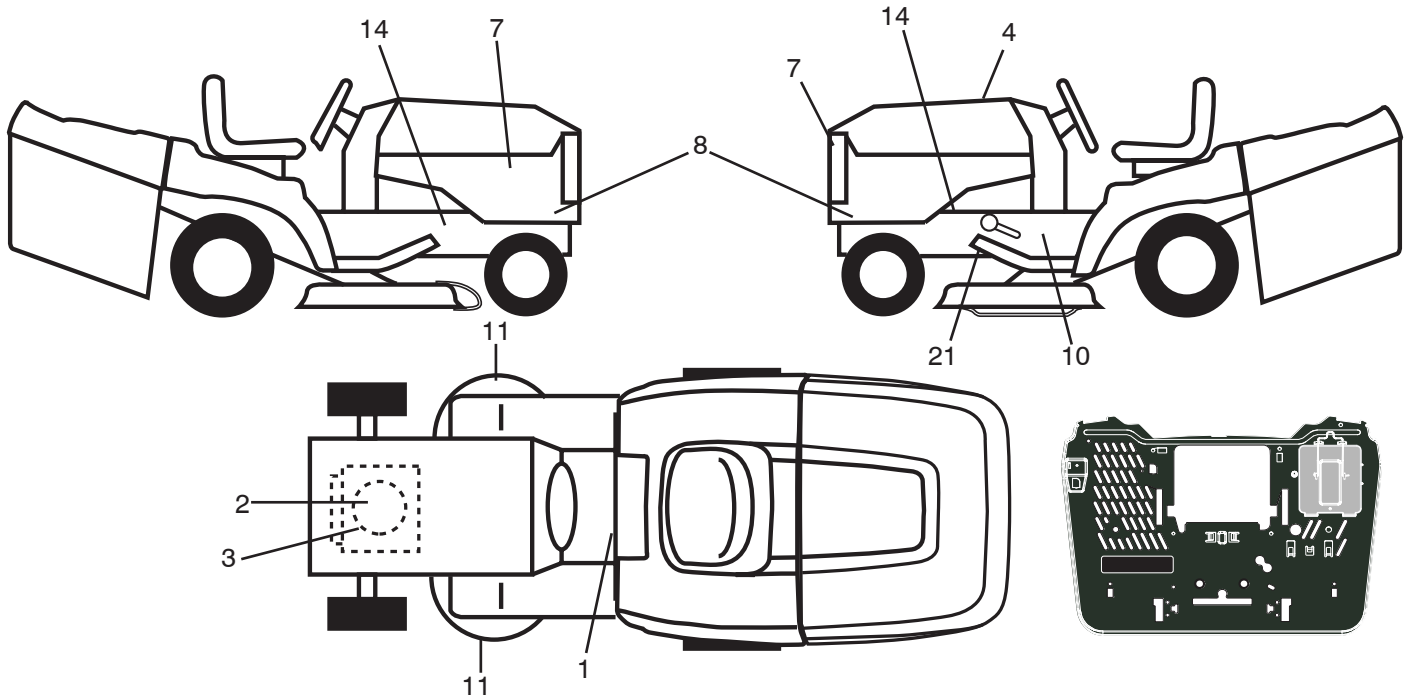

KEY NO.	PART NO.	DESCRIPTION
1	581 57 83-01	Decal, Warn Combined
2	581 57 97-01	Decal, Warning Eng. Sym.
3	587 38 53-01	Decal, Engine
4	589 41 38-01	Decal, Replacement
7	581 62 73-01	Decal, Hood
8	589 42 98-01	Decal, Side Panel
10	581 57 98-01	Decal, Warning
11	581 57 91-01	Decal, Mower Cut Finger Symbol
14	581 57 96-01	Decal, Chassis Hot Muffler

KEY NO.	PART NO.	DESCRIPTION
21	532 44 11-89	Decal, Belt Schematic
--	532 44 54-93	Decal, Warning
--	532 44 46-19	Decal, Bypass
--	532 44 14-09	Pad Footrest LH
--	532 44 14-10	Pad Footrest RH
--	115 85 48-20	Manual Operator's (Euro)
--	115 85 49-10	Manual Operator's (Scan)
--	115 85 51-50	Manual Operator's (E-Bloc)
--	115 85 52-40	Manual Operator's (Baltic)

**WHEELS AND TIRES**

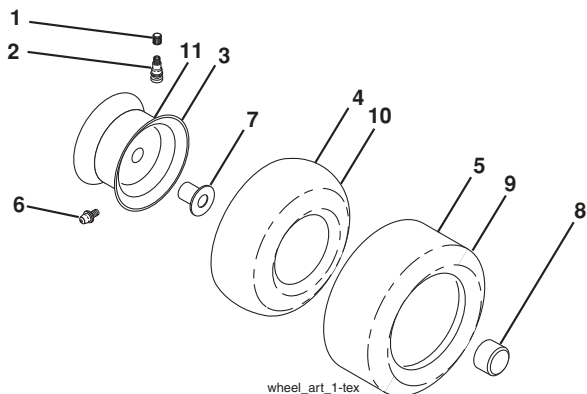

wheel\_art\_1-tex

KEY NO.	PART NO.	DESCRIPTION
1	532 05 91-92	Cap Valve Tire
2	532 06 51-39	Stem Valve
3	532 13 83-36	Rim Front
4	532 05 99-04	Tube Front (Service Item Only)
5	532 10 62-22	Tire Front 15 x 6-6
6	532 12 49-57	Fitting Grease (Front Wheel Only)
7	532 12 49-59	Bearing Flange (Front Wheel Only)
8	532 17 50-39	Cap Axle Blk 1 50 x 1 00
9	532 12 46-35	Tire Rear 18 x 8.5 - 8 C
10	532 12 49-26	Tube Rear (Service Item Only)
11	532 13 83-37	Rim Asm 8" Rear
--	532 14 43-34	Sealant, Tire (10 oz. Tube)

**NOTE:** All component dimensions given in U.S. inches  
 1 inch = 25.4 mm

# TRACTOR - MODEL NO. TC 139T (96051014500), PRODUCT NO. 960 51 01-45

## SCHEMATIC **38**

SCH17

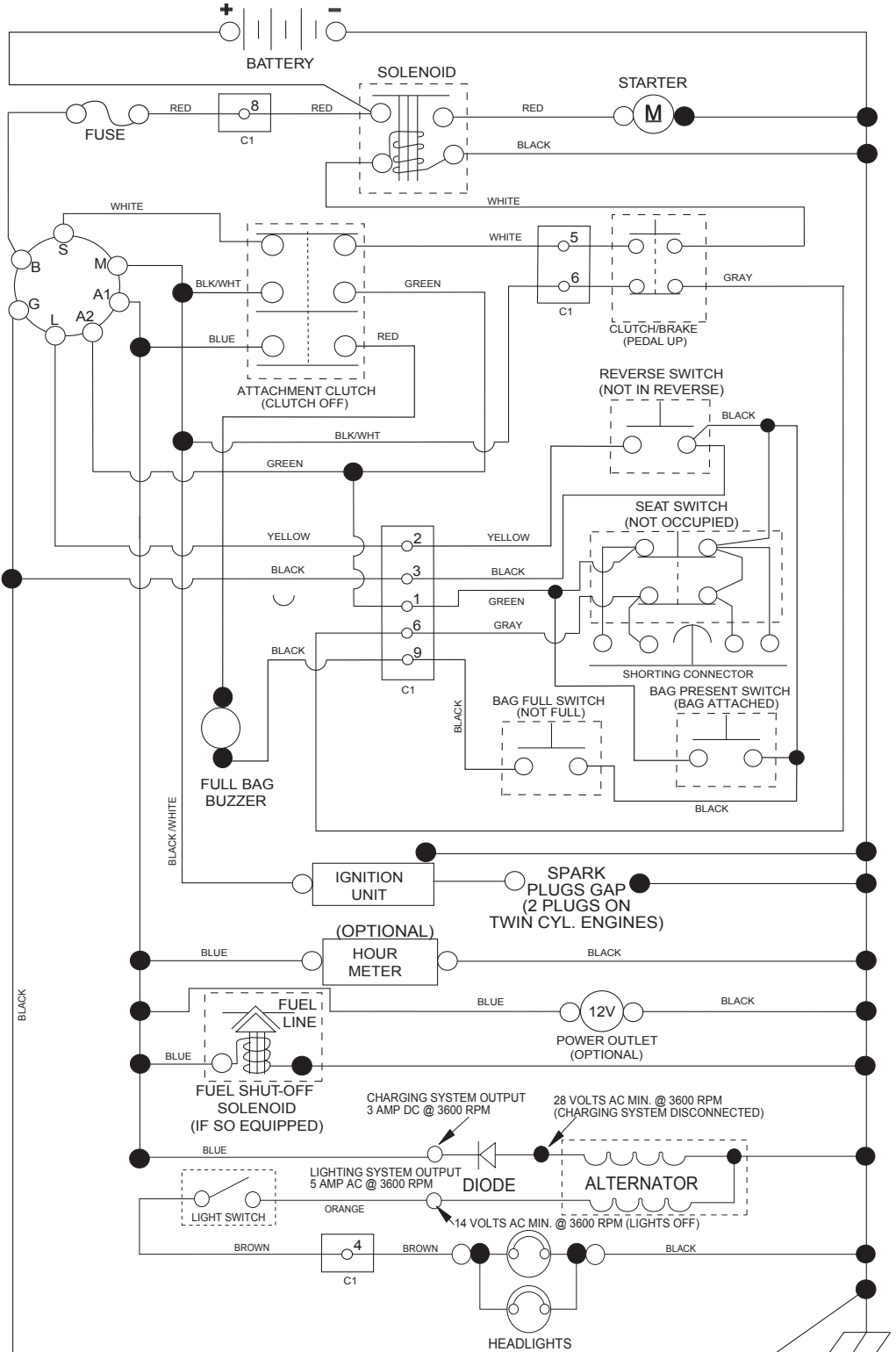

**NOTE**  
YOUR TRACTOR IS EQUIPPED WITH A SPECIAL ALTERNATOR SYSTEM. THE LIGHTS ARE NOT CONNECTED TO THE BATTERY, BUT HAVE THEIR OWN ELECTRICAL SOURCE. BECAUSE OF THIS, THE BRIGHTNESS OF THE LIGHTS WILL CHANGE WITH ENGINE SPEED. AT IDLE THE LIGHTS WILL DIM. AS THE ENGINE SPEED IS INCREASED, THE LIGHTS WILL BECOME THEIR BRIGHTEST.

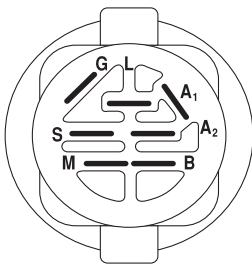

IGNITION SWITCH

POSITION	CIRCUIT	"MAKE"
OFF	M+G+A1	
RUN/OVERRIDE	B+A1	
RUN	B+A1	L+A2
START	B + S + A1	

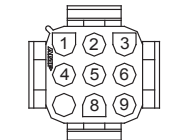

CHASSIS HARNESS CONNECTOR (C1) (MATING SIDE)

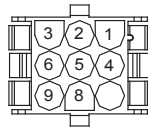

DASH HARNESS CONNECTOR (C1) (MATING SIDE)

WIRING INSULATED CLIPS  
NOTE: IF WIRING INSULATED CLIPS WERE REMOVED FOR SERVICING OF UNIT, THEY SHOULD BE RE-INSTALLED TO PROPERLY SECURE YOUR WIRING.

● NON-REMOVABLE CONNECTIONS

○ REMOVABLE CONNECTIONS

**TRACTOR - MODEL NO. TC 139T (96051014500), PRODUCT NO. 960 51 01-45**  
**ELECTRICAL 32**

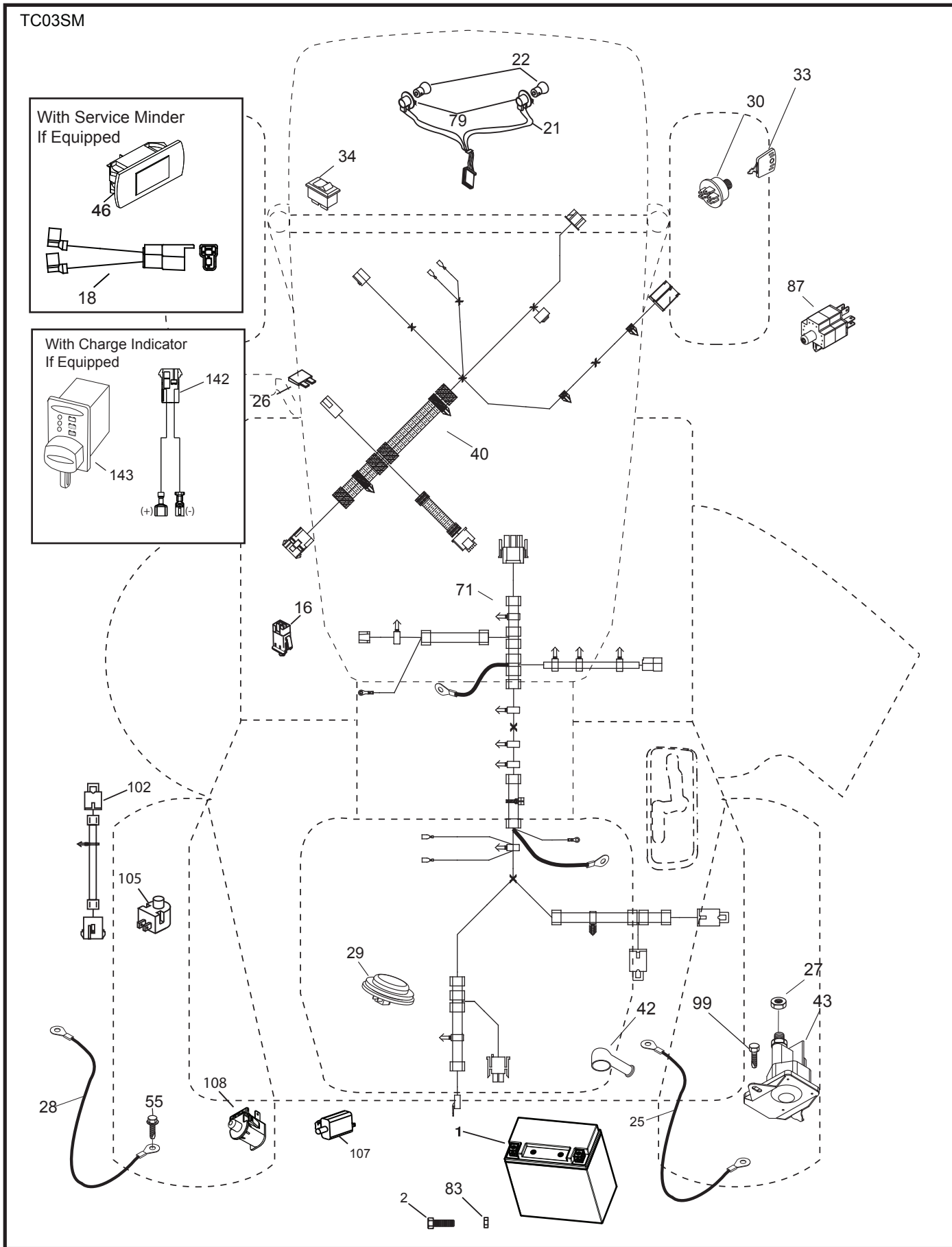

**TRACTOR - MODEL NO. TC 139T (96051014500), PRODUCT NO. 960 51 01-45**  
**ELECTRICAL 32**

<b>KEY NO.</b>	<b>PART NO.</b>	<b>DESCRIPTION</b>
1	532 43 71-57	Battery
2	532 44 09-23	Screw Hex Hd Cap M6 x 1.12mm
16	532 17 61-38	Switch Interlock Push-In
21	532 40 02-52	Harness Light w/4152J
22	532 00 41-52	Bulb Light
25	589 32 37-01	Batt 8 Ga. Red 9 TCRD GN2
26	532 17 51-58	Fuse
27	873 51 04-00	Nut Keps Hex 1/4-20 unc
28	589 32 36-01	Cable Batt BICK10 SIV TCRD GN2
29	532 40 15-45	Switch, Seat
30	532 19 33-50	Switch, Ign
33	532 41 19-35	Key/Chain
34	532 11 07-12	Switch Light/Reset
40	585 84 99-01	Harness Ign. Dash
42	532 13 15-63	Cover, Terminal, Red
43	582 04 28-01	Solenoid
55	817 06 05-12	Screw Thdrol 5/16-18 x 3/4 TYTT
71	587 26 87-01	Harness Ignition Chassis
79	532 17 52-42	Socket Asm. Bulb
83	532 43 67-74	Nut Square M6 x 1.8.5 x 11mm
87	532 42 10-60	Switch
99	817 67 04-12	Screw Hex Whs. Thdrol. 1/4-20 x 3/4
102	532 44 12-62	Harness Jumper
105	532 40 75-68	Switch Reverse
107	532 18 03-79	Switch Full Bagger
108	589 50 03-01	Switch Snapmount
142	583 85 78-01	Harness Charge Port
143	532 44 80-59	Charge Port

**NOTE:** All component dimensions given in U.S. inches  
 1 inch = 25.4 mm

**TRACTOR - MODEL NO. TC 139T (96051014500), PRODUCT NO. 960 51 01-45**  
**CHASSIS AND ENCLOSURES 39**

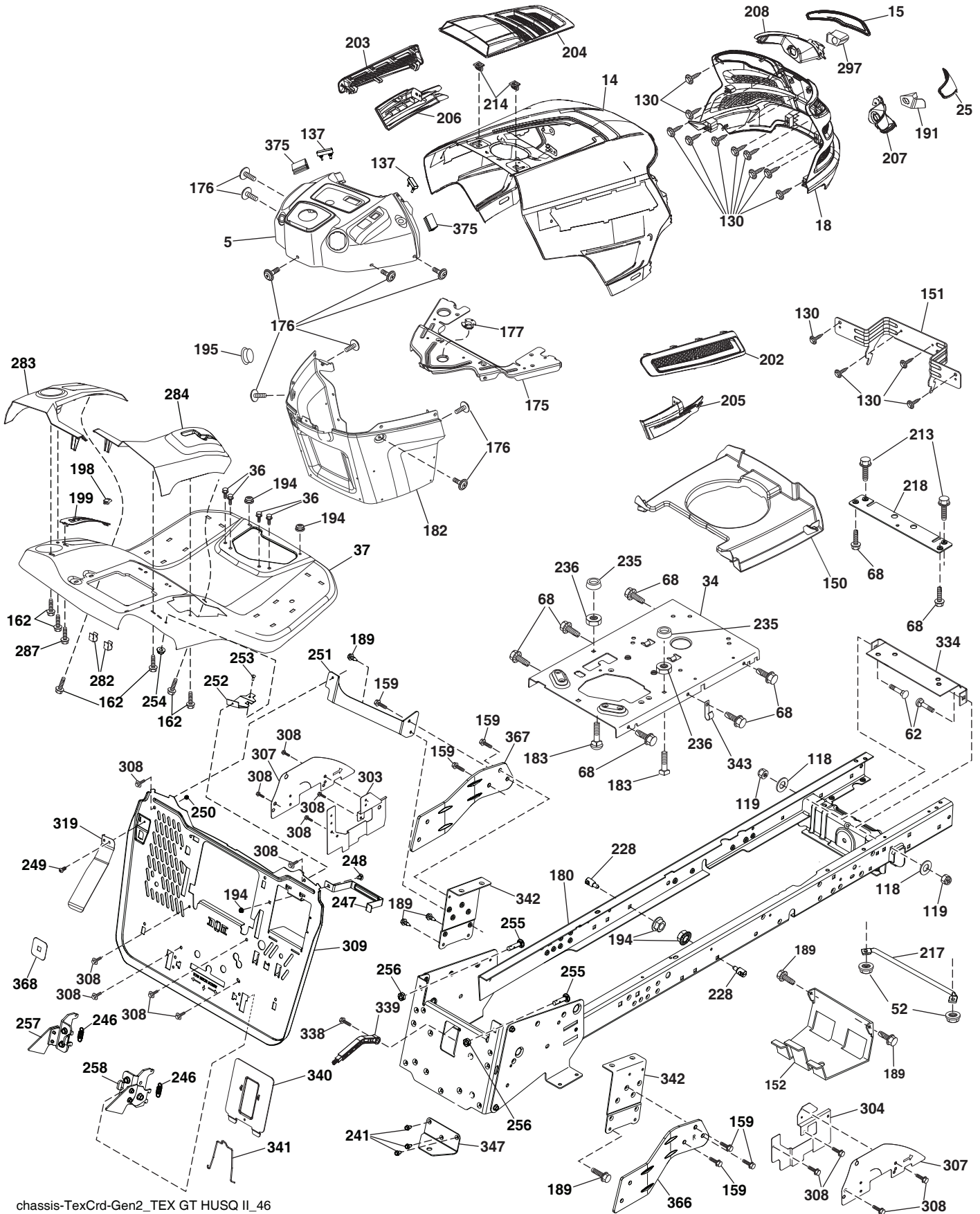

chassis-TeXCrd-Gen2\_TEX GT HUSQ II\_46

**TRACTOR - MODEL NO. TC 139T (96051014500), PRODUCT NO. 960 51 01-45**  
**CHASSIS AND ENCLOSURES 39**

KEY NO.	PART NO.	DESCRIPTION	KEY NO.	PART NO.	DESCRIPTION
5	581 46 68-05	Dash	235	532 40 61-29	Spacer Fender
14	532 44 11-77	Hood	236	873 93 05-00	Nut Lock 5/16-18 unc
15	532 43 97-33	Lens LH	241	817 06 05-16	Screw 5/16-18 x 1
18	532 44 06-53	Grille	246	582 05 20-01	Bagger Latch Extension Spring
25	532 44 33-85	Lens RH	247	582 55 26-02	Battery Strap
34	580 91 09-01	Plate Engine	248	872 11 05-04	Bolt Rdhd Sqnk 5/16-18 x 1/2 Gr. 5
36	817 06 05-12	Screw 5/16-18 x 3/4	249	586 93 60-01	Screw Bnhd 10-24 x 1/2 Patched
37	532 44 13-69	Fender	250	539 97 69-77	Nut Lock Hx w/ins 10-24 unc
52	873 68 05-00	Nut Lock 5/16-18	251	589 31 89-04	LH Backplate Support Bracket
62	872 11 06-08	Bolt RdHd Sqnk 3/8-16 x 1 Gr. 5	252	581 99 22-04	RH Backplate Support Bracket
68	817 49 05-08	Screw Thdrol 5/16-18 x 1/2	253	872 11 04-06	Bolt Rdhd Sqnk 1/4-20 x 3/4 Gr. 5
118	819 13 13-16	Washer 13/32 x 13/16 x 16 Ga.	254	873 90 04-00	Nut Lock Hex Flange 1/4-20
119	873 68 06-00	Nut Crownlock 3/8-16 unc	255	589 39 22-02	Bolt Cross Drilled 3/8-16 x 1.75
130	532 41 63-58	Screw #10 x 0.750	256	532 19 70-33	Nut Jam 3/8-16
137	532 40 75-90	Bumper Dash	257	589 74 66-02	Bagger Latch Assembly LH
150	532 43 97-74	Air Duct	258	589 74 67-02	Bagger Latch Assembly RH
151	532 43 66-70	Bracket Pivot	282	532 41 41-10	Clip Retainer
152	532 19 95-35	Shield Browning	283	532 44 72-12	Console Deck Lift LH
159	817 00 06-12	Screw Hexwsh Thrd 3/8-16 x 3/4	284	532 44 72-20	Console Shft RH
162	532 14 24-32	Screw	287	817 60 04-06	Screw 1/4-20 x 3/8
175	532 19 63-04	Crossmember	297	532 43 74-56	Insert Reflective LH
176	532 40 07-76	Screw 10-24 x 5/8	303	587 49 31-02	Shield Chassis French LH
177	532 19 52-28	Bushing Steering	304	587 49 27-02	Shield Chassis French RH
180	583 90 27-01	Chassis	307	587 49 45-01	Shield Upper French
182	586 73 86-02	Dash Lower	308	532 17 18-77	Bolt 5/16-18 unc x 3/4 w/Sems
183	874 52 05-20	Bolt 5/16-18 x 1-1/4	309	582 55 25-02	Backplate
189	817 00 05-12	Screw 5/16-18 x 3/4	319	581 31 39-07	Lever Bag
191	532 43 74-55	Insert Reflective RH	334	532 44 25-37	Bracket Engine
194	873 90 05-00	Nut Lock Hex Flange 5/16-18	338	532 43 66-40	Bolt Shoulder
195	532 40 41-37	Plug Hole Dash Lower	339	532 43 66-41	Lever Bagger Full
198	532 44 15-52	Indicator Deck Lift	340	582 55 27-02	Battery Door
199	532 41 87-39	Plate Deck Lift	341	582 06 08-01	Battery Door Latch
202	532 43 97-28	Vent Side Hood RH	342	582 82 68-02	Supprt Fender
203	532 43 97-27	Vent Side Hood LH	343	532 44 07-49	Clip
204	587 48 58-01	Vent Top Hood	347	532 44 28-87	Hitch Tow
205	532 43 97-30	Skirt Hood Side RH	366	581 31 46-02	Bracket RH Front Bagger
206	532 43 97-29	Skirt Hood Side LH	367	581 31 45-02	Bracket LH Front Bagger
207	532 43 97-34	Bezel RH	368	581 42 48-01	Full Lever Shroud
208	532 43 97-35	Bezel LH	375	586 90 82-01	Dash Clip-On Bumper
213	874 76 05-12	Bolt 5/16-18 x 3/4	--	532 43 99-76	Plug Dash
214	532 19 91-45	Clip Retainer Tinner	--	532 44 81-32	Kit SVC CRD Gearbox
217	532 40 91-67	Rod Pivot			
218	532 19 63-95	X-Piece Hood Stop			
228	532 19 51-61	Stud Fastner			

**NOTE:** All component dimensions given in U.S. inches  
1 inch = 25.4 mm



TRACTOR - MODEL NO. TC 139T (96051014500), PRODUCT NO. 960 51 01-45  
DRIVE **40**

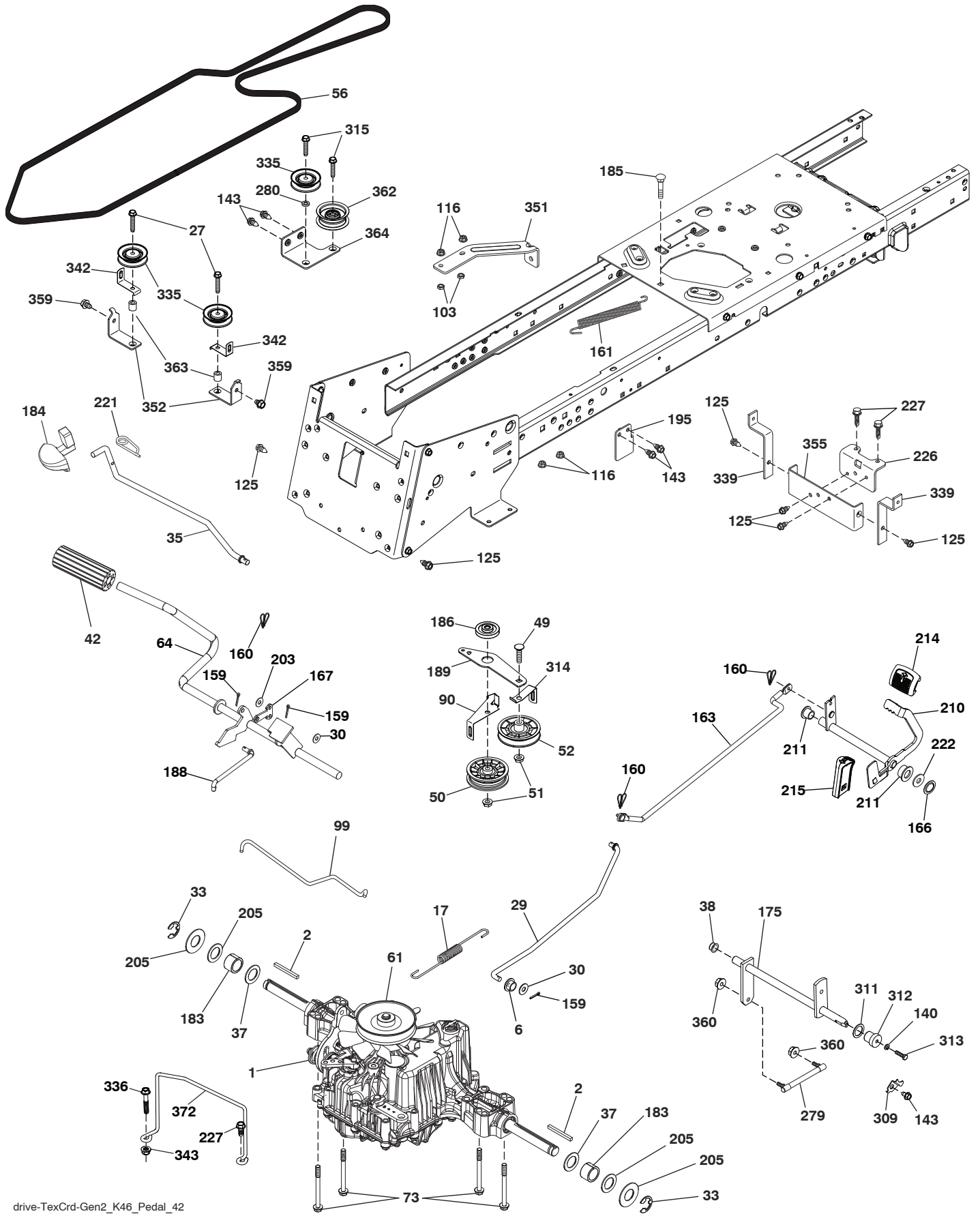



**TRACTOR - MODEL NO. TC 139T (96051014500), PRODUCT NO. 960 51 01-45  
DRIVE **40****

KEY NO.	PART NO.	DESCRIPTION	KEY NO.	PART NO.	DESCRIPTION
1	-----	Transaxle, Tufftorq K46DF (446488) (Order parts from trans-axle manufacturer.)	195	580 45 69-01	Bracket Rod Brake CRD Tex
2	532 12 35-83	Key Square	203	819 11 11-16	Washer 11/32 x 11/16 x 16 Ga.
6	532 12 40-28	Bushing Snap	205	532 12 17-48	Washer 25/32 x 1-5/8 x 16 Ga.
17	532 43 62-27	Spring Brake K46	210	532 40 09-80	Rocker Asm. Pedal Control
27	817 49 05-28	Screw Hexwsh Thd 5/16-18 x 1-3/4	211	532 12 01-83	Bearing Nylon
29	532 44 27-95	Rod, Brake	214	532 42 12-63	Pedal Forward
30	819 13 16-16	Washer	215	586 60 65-02	Pedal Reverse
33	812 00 00-01	Ring E	221	532 40 31-87	Retainer Spring Clip Handle
35	583 86 45-01	Rod, Brake, Park	222	879 21 20-10	Washer 21/32 x 1-1/4 10 Ga.
37	532 18 89-67	Washer Harden .793 x 1.063 x .060	226	532 40 15-64	Bracket Strap Torque
38	532 16 96-13	Nyliner Bushing	227	817 49 05-12	Screw
42	532 12 48-74	Cover, Foot Pedal	279	532 44 42-83	Link Shift
49	872 11 06-14	Bolt Rdhd 3/8-16 unc x 3/4 Gr. 5	280	819 11 10-12	Washer 11/32 x 5/8 x 12 Ga.
50	532 19 43-27	Idler Flat	309	532 16 55-81	Plate Fstnr Cross Shf
51	873 90 06-00	Lock Nut 3/8-16	311	532 16 98-45	Washer Nylon
52	532 19 43-26	Idler V-Groove	312	532 16 56-14	Hub Tapered
56	532 44 27-81	V-Belt, Drive	313	874 78 04-16	Bolt Hex Fin 1/4-20 unc x 1 Gr. 5
61	532 44 51-51	Pulley Transaxle K46	314	532 44 47-13	Keeper Belt
64	532 19 78-65	Shaft Asm. Pedal Brake Control	315	817 58 05-20	Screw Thdrol 5/16-18 x 4.25
73	874 49 05-44	Bolt Flanged	335	532 19 95-34	Pulley V-Idler
90	532 44 36-05	Keeper Belt Clutching	336	587 25 96-01	Bolt 5/16-18 x 1-3/4 Flanged hex
99	532 44 39-47	Rod Spring Bypass	339	532 43 68-67	Strap Torque K46 CRD Tex
103	873 35 05-00	Nut Hex Jam 5/16-18	342	532 18 26-82	Keeper Belt 2.5" STL V-Idlr CRD
116	873 90 05-00	Nut Lock Hex Flange 5/16-18	343	539 11 28-99	Nut 5/16-18 Hex Flanged Nyloc
125	817 00 05-12	Screw 5/16-18 x 3/4	351	532 43 69-98	Bracket 97 CRD Deck Sway
140	810 04 04-00	Washer Lock Hvy Helical 1/4	352	532 43 56-45	Bracket Idler CRD Tex
143	817 49 05-08	Screw 5/16-18 x 1/2	355	532 43 56-69	Bracket
159	876 02 04-12	Pin Cotter 1/8 x 3/4	359	817 49 06-10	Screw Thdrol 3/8-16 x 5/8
160	532 16 94-84	Retainer Clip	360	532 44 47-14	Nut 5/16-24 unf
161	532 10 57-09	Spring, Return, Clutch	362	532 43 68-12	Idler Flat
163	532 44 27-93	Rod Control	363	532 44 27-80	Spacer .343 x .63 x .62
166	532 42 91-64	Nut Push	364	532 44 30-32	Bracket Idler CRD Tex
167	532 40 52-57	Latch Brake Parking	372	582 65 49-01	Keeper Belt Transaxle
175	532 42 93-59	Shaft Asm Crossshift Rear CRD			
183	532 13 70-57	Spacer Axle			
184	587 65 37-01	Handle Parking Brake			
185	872 11 06-22	Bolt 3/8-16 unc x 2-3/4 Gr. 5			
186	532 19 43-21	Spacer Retainer			
188	582 21 70-01	Link Clutch			
189	532 43 36-11	Bellcrank Ground Drive			

**NOTE:** All component dimensions given in U.S. inches  
1 inch = 25.4 mm

TRACTOR - MODEL NO. TC 139T (96051014500), PRODUCT NO. 960 51 01-45  
ENGINE **24**

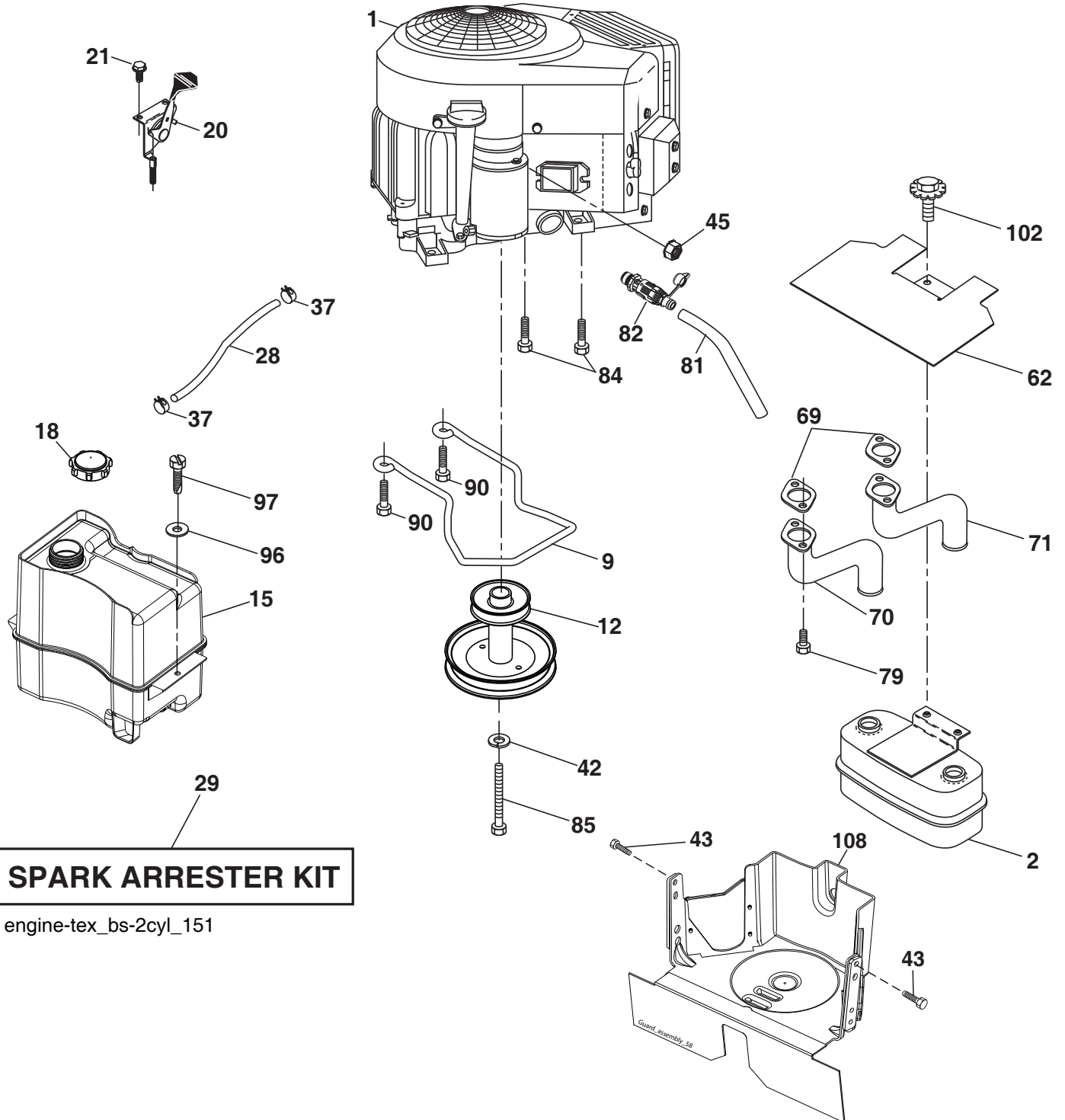

**SPARK ARRESTER KIT**

engine-tex\_bs-2cyl\_151

**TRACTOR - MODEL NO. TC 139T (96051014500), PRODUCT NO. 960 51 01-45  
ENGINE 24**

<b>KEY NO.</b>	<b>PART NO.</b>	<b>DESCRIPTION</b>
1	-----	Engine B&S Model No. 40N777-0009-B1 (582593401) (Order parts from engine manufacturer.)
2	589 81 87-01	Muffler
9	501 83 26-02	Keeper Belt Engine
12	586 47 85-01	Pulley Engine
15	581 29 01-01	Tank Fuel
18	532 43 02-20	Fuel Cap
20	587 24 25-01	Control Throttle
21	532 41 63-58	Screw # 10 x 0.750
28	532 13 70-40	Fuel Line
29	532 13 71-80	Spark Arrester Kit
37	532 12 34-87	Clamp Hose
42	810 04 07-00	Washer Lock 7/16
45	873 51 04-00	Nut Keps Hex 1/4-20 unc
62	532 43 40-17	Shield Heat Muffler
69	532 16 53-91	Gasket
70	581 88 11-01	Tube Exhaust LH
71	581 88 10-01	Tube Exhaust RH
79	532 18 39-06	Screw
81	532 14 84-56	Tube Drain Oil Easy
82	532 42 82-87	Valve Oil Drain
84	817 06 06-20	Screw
85	501 60 65-01	Bolt Hex 7/16-20 x 4 x Gr. 5-1.5 Thr
90	817 00 06-16	Screw 3/8-16 x 1
96	819 09 14-16	Washer 9/32 x 7/8 x 16 Ga.
97	817 67 04-12	Screw 1/4-20 x 3/4
102	817 00 05-12	Screw 5/16-18 x 3/4
108	587 17 95-02	Cover Pulley Eng. w/SHLD

**NOTE:** All component dimensions given in U.S. inches  
1 inch = 25.4 mm

**TRACTOR - MODEL NO. TC 139T (96051014500), PRODUCT NO. 960 51 01-45**  
**STEERING ASSEMBLY 41**

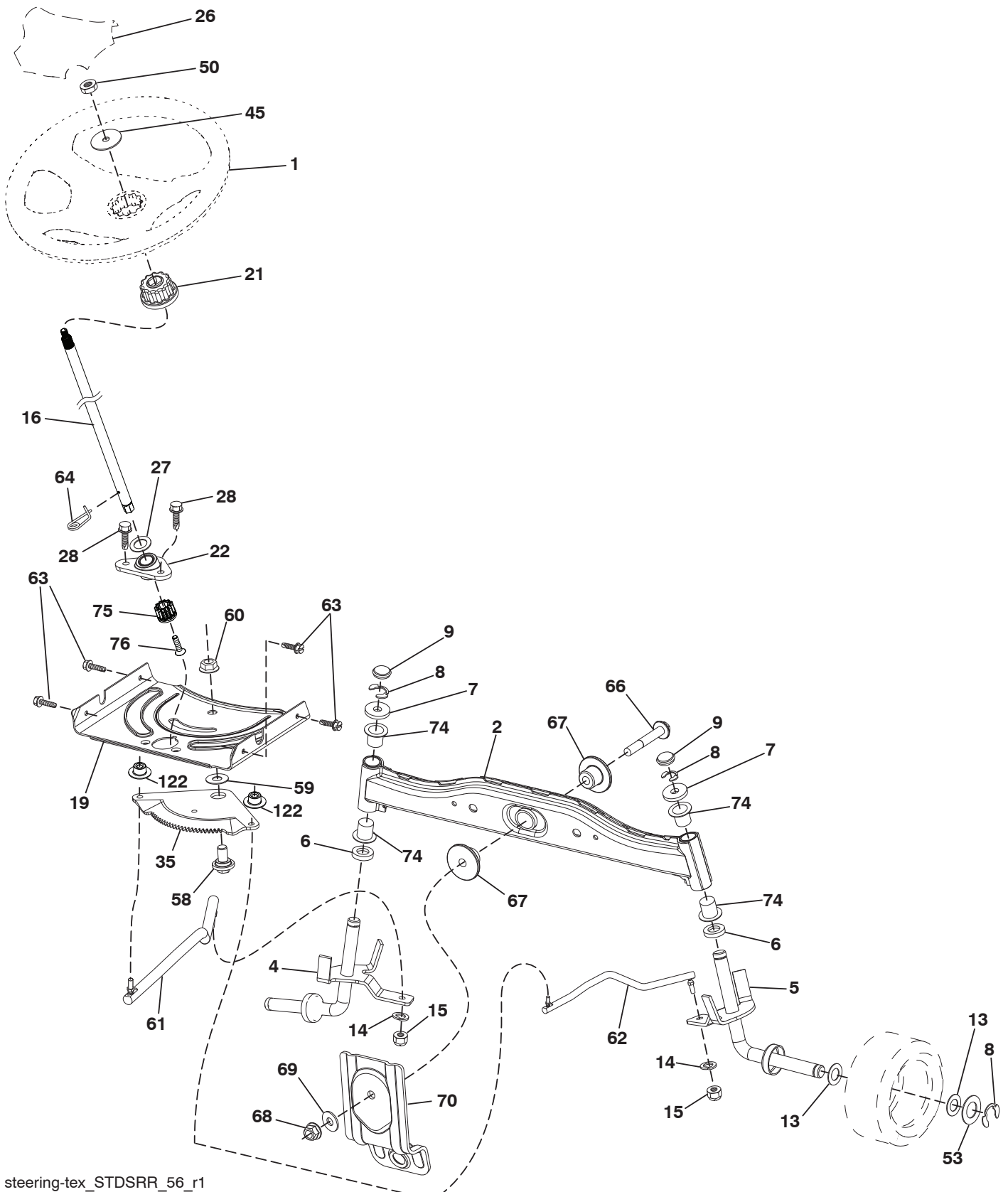

steering-tex\_STDSRR\_56\_r1

**TRACTOR - MODEL NO. TC 139T (96051014500), PRODUCT NO. 960 51 01-45  
STEERING ASSEMBLY 41**

<b>KEY NO.</b>	<b>PART NO.</b>	<b>DESCRIPTION</b>
1	532 43 99-97	Wheel, Steering
2	532 41 81-68	Axle Asm.
4	532 40 30-87	Spindle, LH
5	532 40 30-88	Spindle, RH
6	532 12 49-31	Washer Thrust 0.75 x 1.23
7	532 12 17-48	Washer 25/32 x 1-5/8 x 16 Ga.
8	812 00 00-29	Ring, Klip #T5304-75
9	532 12 12-32	Cap, Spindle
13	532 12 17-49	Washer 25/32 x 1-1/4 x 16 Ga.
14	810 04 06-00	Washer, Lock 3/8
15	873 54 06-00	Nut, Crown Lock 3/8-24 unf
16	587 01 60-02	Steering Shaft
19	532 19 47-29	Plate Steering
21	586 84 02-01	Adapter Wheel Steering
22	585 02 98-02	Bearing
26	532 43 97-43	Insert, Wheel Steering
27	819 21 16-16	Washer
28	817 00 06-12	Screw 3/8-16 x 3/4
35	532 19 47-32	Gear, Sector Plate
45	587 01 64-01	Washer 3/8 ID 2-3/8 OD 12 Ga. PLTD
50	873 90 06-00	Nut Lock Flg 3/8-16 unc
53	532 18 89-67	Washer Hardened .793 x 1.637 x .060
58	532 19 47-47	Bolt Shoulder Sector Pivot CFM
59	532 19 47-48	Washer Thrust Sector Steering
60	873 97 10-00	Nut Flange Lock 5/8-11
61	532 19 47-40	Draglink, LH
62	532 19 47-41	Draglink, RH
63	817 00 05-12	Screw 5/16-18 x 3/4
64	532 19 98-49	Retainer Clip Spring Steering
66	871 02 07-48	Bolt Hex Fghd 7/16-14 x 3 Serr
67	532 19 47-37	Bushing PM Front Axle
68	873 90 07-00	Nut Lock Flange 7/16-14 Gr. 5
69	532 19 91-62	Washer 1.5 x .505 x .118
70	585 33 88-01	Bracket Deck Susp. Front
74	532 12 49-37	Bearing
75	580 68 37-01	Pinion
76	580 68 36-01	Screw Head Sock
122	532 44 49-62	Cap Gear

**NOTE:** All component dimensions given in U.S. inches  
1 inch = 25.4 mm

TRACTOR - MODEL NO. TC 139T (96051014500), PRODUCT NO. 960 51 01-45  
MOWER DECK 44

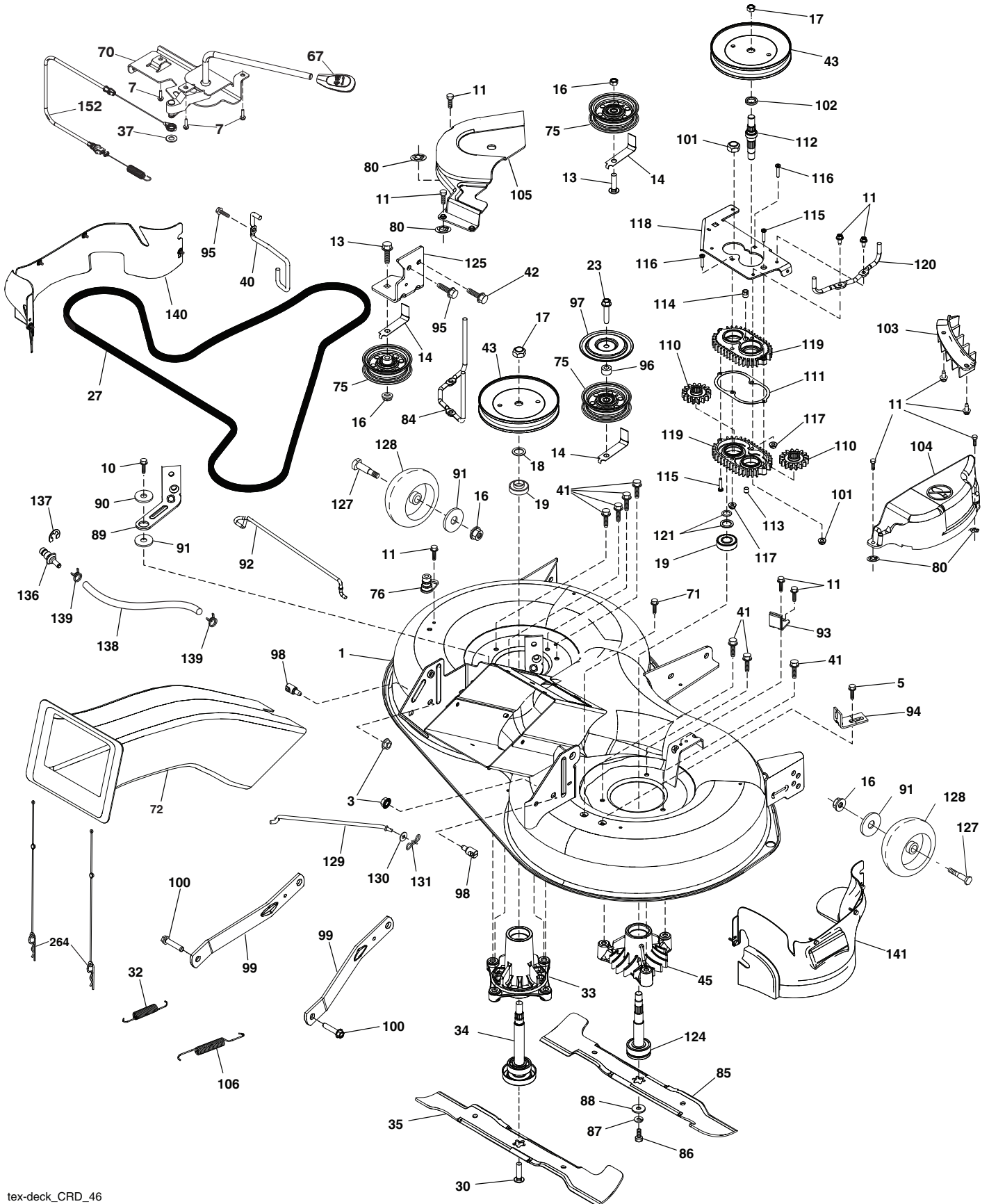

tex-deck\_CRD\_46



**TRACTOR - MODEL NO. TC 139T (96051014500), PRODUCT NO. 960 51 01-45**  
**MOWER DECK 44**

KEY NO.	PART NO.	DESCRIPTION	KEY NO.	PART NO.	DESCRIPTION
1	532 44 09-71	Deck Weldment	102	532 40 25-11	Spacer Bearing Swing Plate
3	873 90 05-00	Nut Lock Hex Flange 5/16-18	103	532 43 69-92	Guard Front Vent
5	817 00 05-10	Bolt 5/16-18	104	532 43 89-68	Mandrel Cover RH
7	532 41 63-58	Screw #10 x 0.750 BOS Thread	105	532 43 87-44	Mandrel Cover LH
10	817 00 06-16	Screw 3/8-16x1 smgml tap	106	532 19 32-16	Spring Brake Return
11	532 13 77-29	Screw Thd Roll 1/4 - 20 x 5/8	110	587 93 48-01	Gear Output
13	872 11 06-12	Bolt Carr Sh 3/8-16 x 1-1/2 Gr. 5	111	532 43 69-79	Gasket Gearcase
14	532 15 60-85	Keeper Belt Idler	112	532 44 38-52	Shaft Gearcase Adapter
16	873 90 06-00	Nut Lock FIG 3/8 - 16 unc	113	532 43 85-33	Plug Oil
17	532 40 02-34	Nut Flange Lock Top	114	588 17 05-01	Valve Relief
18	532 18 76-90	Washer Spacer Mandrel	115	818 03 10-16	Screw Torx #10-24 x 1
19	585 32 39-01	Bearing Mandrel	116	872 11 04-14	Bolt 1/4-20 x 1.75 Gr. 5
23	817 49 06-28	Screw Thdrol 3/8-16 x 1-3/4	117	873 90 04-00	Nut Hex Flange 1/4-20 unc
27	532 43 97-26	V-Belt Drive	118	532 43 69-89	Arm Clutching
30	584 30 93-01	Screw Sems 7/16-20x1 Hex Head	119	532 43 81-66	Gearcase Subasm
32	532 40 18-72	Spring Return Deck	120	532 43 69-91	Keeper Belt RH
33	532 18 72-81	Housing Mandrel 4pt Service	121	532 43 69-85	Washer
34	587 25 65-01	Shaft Asm Mndrl	124	532 43 69-86	Non Greasable Mandrel Shaft
35	532 42 79-84	Blade Mower LH	125	532 44 04-20	Bracket Idler Chassis
37	819 13 13-16	Washer 13/32 x 13/16 x 16 Ga.	127	532 19 34-06	Bolt Shoulder 3/8-16 x 3-5/8 Gr. 5
40	532 19 72-58	Keeper Belt Engine LH	128	532 17 48-73	Wheel Gauge
41	584 95 39-01	Bolt Hex	129	532 44 32-37	Rod Anti-Sway
42	817 00 05-12	Screw 5/16-18 x 3/4	130	819 13 13-12	Washer 13/32 x 13/16 x 12 Ga.
43	532 19 74-73	Pulley Mandrel	131	532 19 42-08	Pin Cotter 5/16 Bow Tie Lock
45	532 13 71-52	Housing Mandrel	136	532 43 96-39	Washout Port
67	532 40 30-12	Handle Clutch Cable	137	812 00 00-29	Ring Clip
70	532 19 99-72	Clutch Asm Manual	138	532 44 07-43	Hose
71	817 67 06-08	Screw 3/8-16 x 1/2	139	532 44 07-42	Hose Clamp
72	581 45 41-03	Chute Upper	140	501 57 94-01	LH Guard
75	532 13 14-94	Pulley Idler Flat	141	501 57 93-01	RH Guard
76	532 43 96-40	Washout Port	152	532 44 04-88	Cable Clutch Manual w/Spring
80	532 42 30-62	Pal Nut	264	589 39 29-01	Retainer Chute Asm
84	532 43 25-20	Keeper Belt LH Mandrel	--	587 25 33-01	Mandrel Assembly
85	532 42 79-85	Blade Mower RH			(Include Ho sing Assembly
86	532 18 17-13	Bolt 3/8-24 x 1.50 Gr. 8			(key#33), Shaft Assembly (key#34
87	810 03 06-00	Washer Lock Hvy. 3/8			and Bearing Only (key#19) - Pulley
88	532 14 02-96	Washer Hard			Nut/Washer And Blade Bolt
89	532 43 81-24	Arm Brake 97 LH			Washers Not Included)
90	532 19 90-92	Spacer Retainer	--	589 47 76-01	Replacement Mower Complete
91	819 13 20-12	Washer 13/32 x 1-1/4 x 12 Ga.	--	532 44 81-32	Gear Case Kit – Use .75 oz. Shell
92	532 43 69-93	Rod Brake Assembly			460 oil (Include Gear Output (key
93	532 43 81-25	Arm Brake RH			#110), Gasket Gearcase (key
94	532 19 72-50	Bracket Clutch Cable			#111), Shaft Gearcase (key#112),
95	817 00 06-12	Screw 3/8-16 x 3/4			Plug Oil (key #113), Vent Breather
96	532 40 02-71	Spacer			1/8 NPT (key #114), Screw Torx
97	532 18 20-61	Shield Idler Mower			(key #115), Gearcase Subasm
98	532 19 51-61	Stud Fastener			(key #119))
99	532 19 51-86	Arm Suspension Mower Rear			
100	532 19 65-39	Bolt Shoulder			
101	873 68 09-00	Nut Crownlock 9/16-18 unc			

**NOTE:** All component dimensions given in U.S. inches  
1 inch = 25.4 mm

**TRACTOR - MODEL NO. TC 139T (96051014500), PRODUCT NO. 960 51 01-45**  
**MOWER LIFT 45**

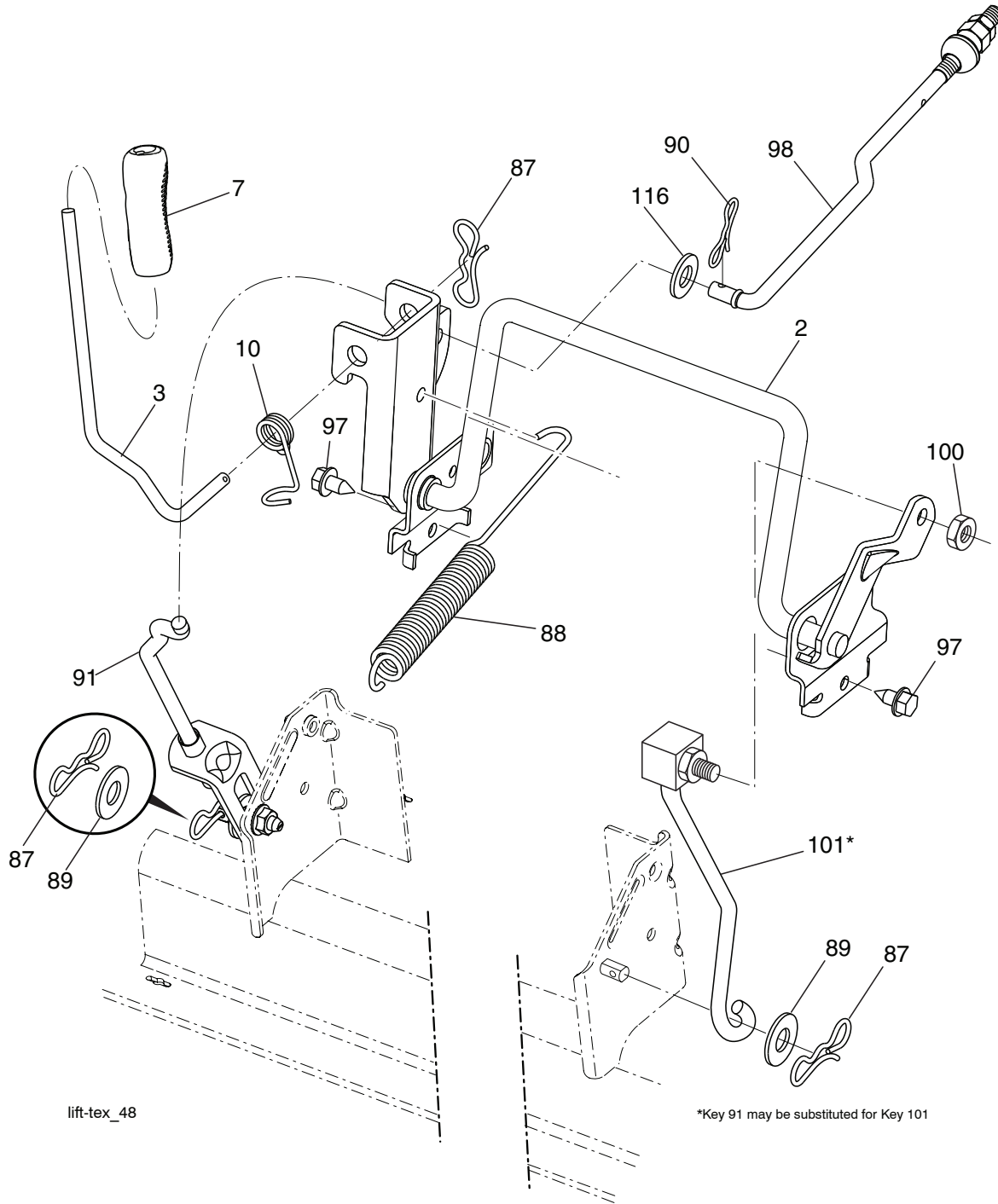

KEY NO.	PART NO.	DESCRIPTION
2	532 43 69-96	Deck Lift Weldment
3	532 19 52-31	Lever Asm., Lift RH
7	580 96 23-01	Grip, Lever
10	532 19 63-14	Spring Torsion
87	532 19 42-09	Pin Cotter 7/16 Bow Tie Lock
88	532 44 54-96	Spring Lift Assist
89	819 19 19-12	Washer Clear Zinc
90	532 19 42-08	Pin Cotter 5/16 Bow Tie Lock
91	532 19 51-81	Link Lift Susp Mower Rear

KEY NO.	PART NO.	DESCRIPTION
97	817 49 06-08	Screw 3/8-16 x 1/2
98	532 19 52-70	Link Lift Susp. Front Mower
100	873 93 06-00	Nut Centerlock
101	532 40 70-03	Link Asm. Lift
116	819 15 15-16	Washer 15/32 x 15/16 x 16 Ga.

**NOTE:** All component dimensions given in U.S. inches  
 1 inch = 25.4 mm

**TRACTOR - MODEL NO. TC 139T (96051014500), PRODUCT NO. 960 51 01-45  
SEAT ASSEMBLY 42**

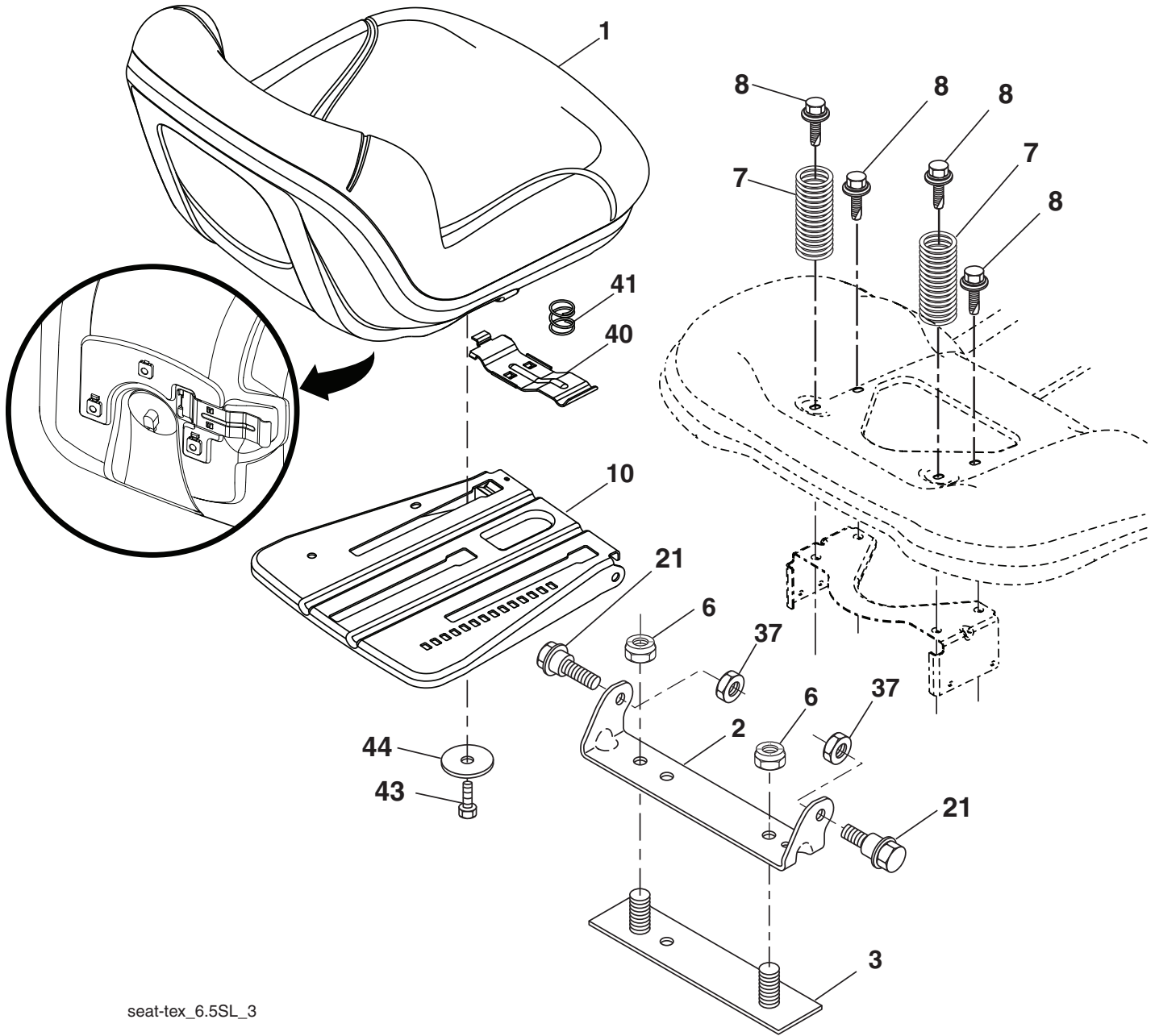

seat-tex\_6.5SL\_3

KEY NO.	PART NO.	DESCRIPTION
1	532 43 97-09	Seat
2	532 18 01-66	Bracket Pivot Fender
3	532 14 06-75	Strap, Asm Fender
6	873 80 06-00	Nut, Lock w/Ins. 3/8-16 unc
7	589 48 35-01	Spring, Seat Cprsn
8	532 17 18-77	Bolt 5/16-18 unc x 3/4 w/Sems
10	532 19 69-77	Pan, Seat
21	587 90 78-01	Bolt, Shoulder 5/16-18 x 5/8

KEY NO.	PART NO.	DESCRIPTION
37	873 80 05-00	Nut, Lock 5/16-18 unc
40	532 19 76-61	Handle Slide Seat
41	532 19 82-00	Spring Latch Seat
43	874 76 06-12	Bolt Fin Hex 3/8-16 unc x 3/4
44	819 13 38-12	Washer 13/32 x 2-3/8 x 12 Ga.

**NOTE:** All component dimensions given in U.S. inches  
1 inch = 25.4 mm

**TRACTOR - MODEL NO. TC 139T (96051014500), PRODUCT NO. 960 51 01-45**  
**BAGGER 46**

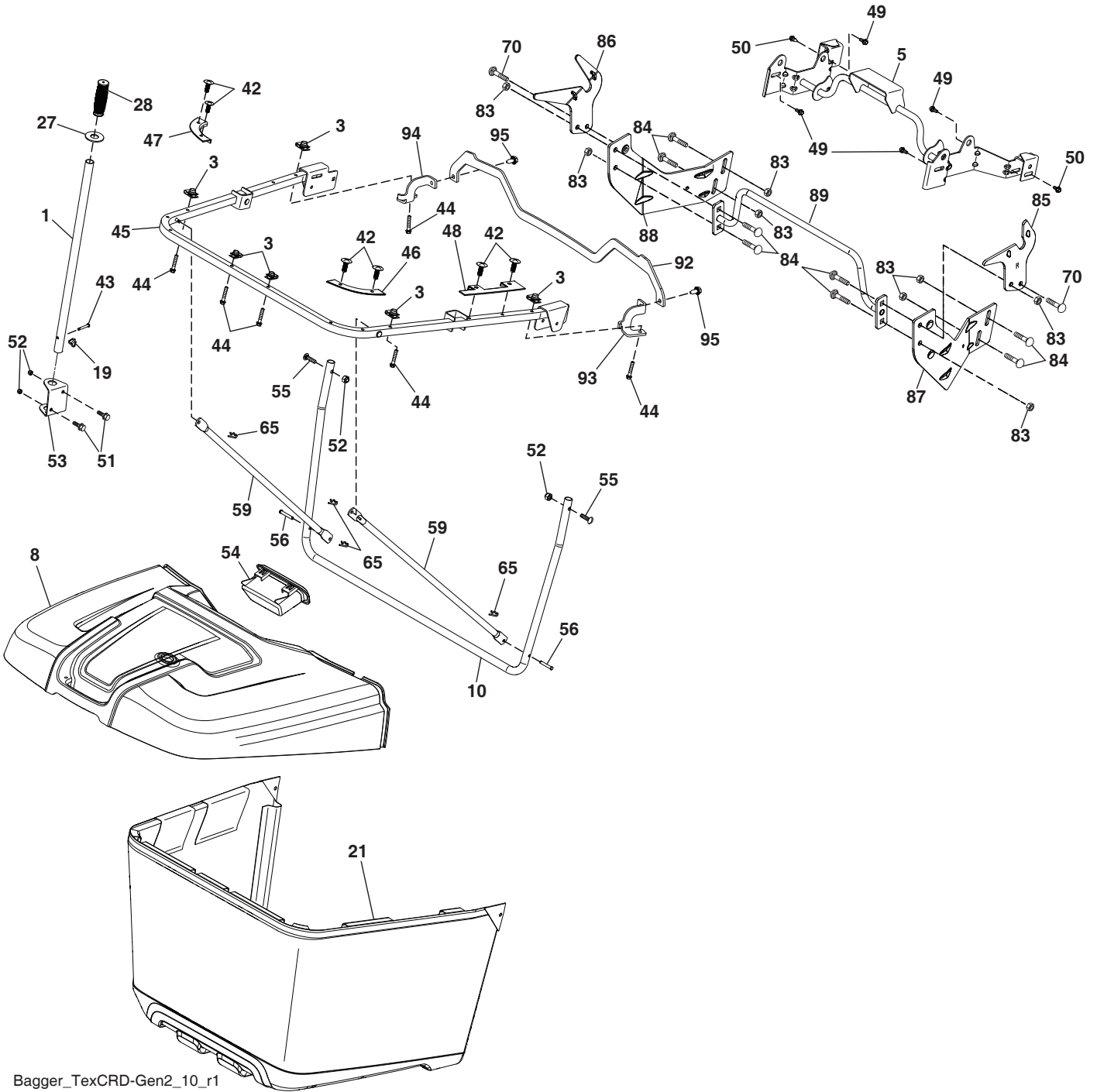

Bagger\_TexCRD-Gen2\_10\_r1

**TRACTOR - MODEL NO. TC 139T (96051014500), PRODUCT NO. 960 51 01-45  
BAGGER 46**

<b>KEY NO.</b>	<b>PART NO.</b>	<b>DESCRIPTION</b>
1	532 42 86-10	Tube Handle Bagger
3	532 17 48-14	Nut Push
5	532 44 37-62	Frame Asm Top Bagger
8	587 58 86-01	Cover Bagger
10	532 44 37-55	Frame Front
19	532 19 42-08	Cotter Pin 5/16 Bow Tie
21	581 33 71-03	Bag Asm
27	532 44 55-29	Grommet Rubber
28	532 16 57-87	Grip Handle Black
42	532 44 04-28	Christmas Tree Clip
43	532 12 68-75	Clevis Pin
44	532 19 96-87	Bolt 1/4-20 1.50
45	532 44 37-54	Upper U Frame Weldment
46	532 44 55-41	Bagger Corner Close-Out RH
47	532 44 40-79	Bagger Corner Close-Out LH
48	532 44 40-80	Top Bagger Side Close-Out
49	532 17 18-73	Bolt Shoulder 5/16-18 TT
50	532 17 18-77	Bolt 5/16-18 unc x 3/4 W/SEMS
51	872 11 05-06	Bolt RDHDSQNK 5/16-18 unc x 3/4
52	873 80 05-00	Nut Lock HX W/INS 5/16-18 unc
53	532 44 41-95	Bracket Dump Handle
54	532 44 72-18	Bagger TOP Front Handle
55	872 14 05-12	Bolt Rdhd Sq 5/16-18 unc x 1-1/2
56	532 42 03-06	Pin Clevis 1.83 OD x 1.26 long
59	532 44 47-63	Bagger Spread Tube
65	532 12 47-88	Retainer Spring 1" Zinc
70	817 00 06-12	Bolt 3/8-16 x 3/4
83	873 80 06-00	Nut Lock Hex w/Ins 3/8-16
84	872 11 06-08	Bolt RDHD SQNK 3/8-16 x 1 Gr. 5
85	581 31 44-02	Bracket RH Pivot
86	581 31 43-02	Bracket LH Pivot
87	581 31 48-02	Bracket RH
88	581 31 47-02	Bracket LH
89	581 31 51-04	Tube Asm.
92	586 05 23-02	Bracket Top Support
93	586 05 24-02	Bracket Support RH
94	586 05 25-02	Bracket Support LH
95	817 00 05-12	Screw 5/16-18 x 3/4
--	501 70 56-01	Bagger Dump Kit (Includes Key#'s 85, 86, 87, 88, & 89)
--	586 74 49-01	Bagger Complete Kit (Includes Key#'s 1, 5, 10, 19, 21, 27, 28, 42, 43, 46, 47, 48, 49, 50, 52, 54, 56, 59, 65)

**NOTE:** All component dimensions given in U.S. inches  
1 inch = 25.4 mm

