

ILLUSTRATED PARTS LIST

MODEL NUMBER ST 224 P

PRODUCT NUMBER 961 93 01-22

MFG. ID. NUMBER 96193012203

REPAIR PARTS

AUGER HOUSING / IMPELLER ASSEMBLY

SNOW THROWER - MODEL NO. ST 224 P (96193012203), PRODUCT NO. 961 93 01-22

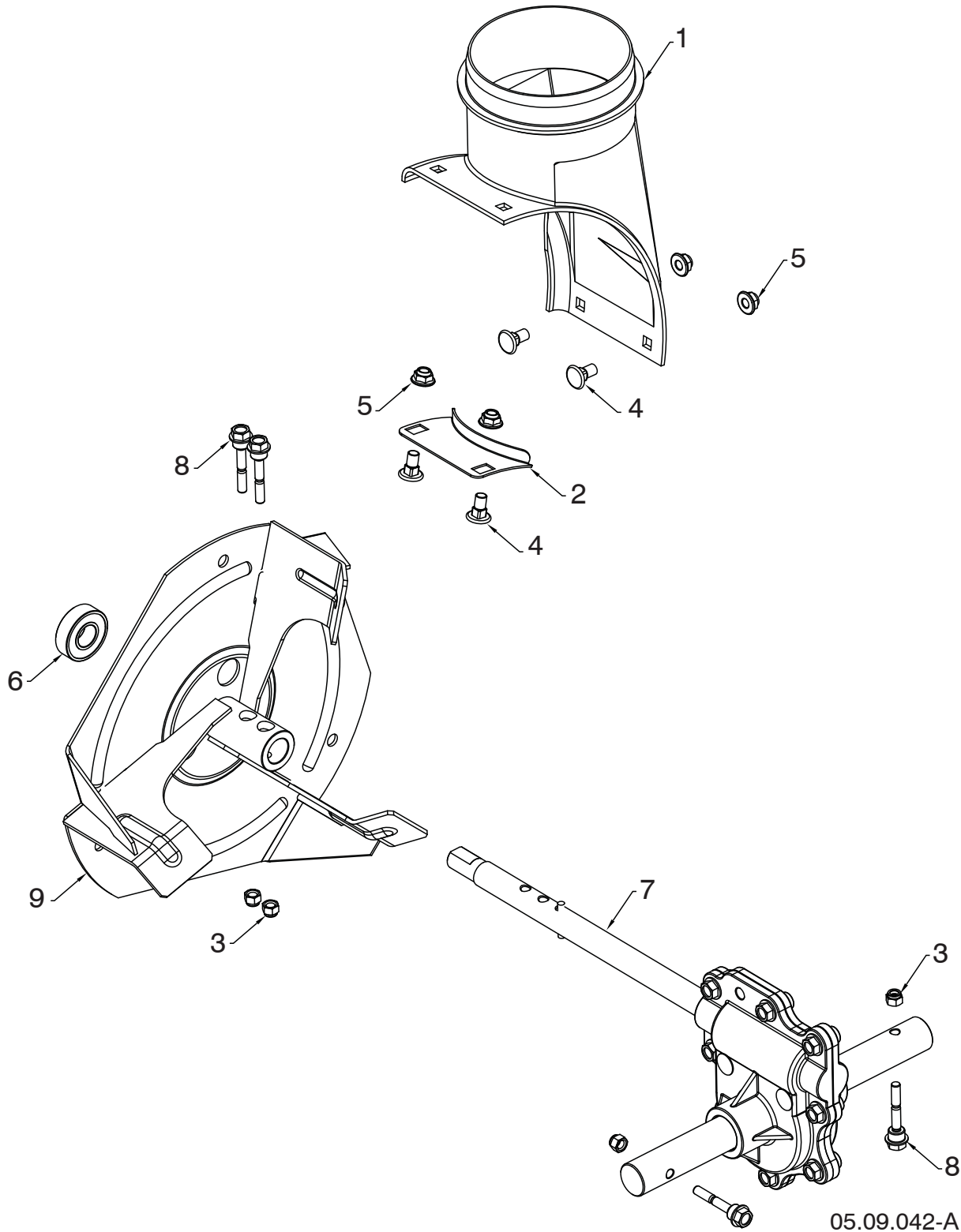

NOTE: All component dimensions given in U.S. inches. 1 inch = 25.4 mm
IMPORTANT: Use only Original Equipment Manufacturer (O.E.M.) replacement parts.
Failure to do so could be hazardous, damage your snow thrower and void your warranty.

REPAIR PARTS**AUGER HOUSING / IMPELLER ASSEMBLY****SNOW THROWER - MODEL NO. ST 224 P (96193012203), PRODUCT NO. 961 93 01-22**

KEY NO.	PART NO.	DESCRIPTION
1	585 05 69-01	CHUTE DISCAHRGE BASE
2	532 18 40-95	BRACKET CORNER DISCHARGE YZP
3	873 80 04-00	NUT NYLOCK 1/4 - 20
4	585 69 12-01	BOLT CAR WAF BLK 5/16-18 X .488
5	585 69 13-01	NUT HEX FLANGE 5/16-18 NYLOCK
6	532 19 87-91	BEARING 1501389 BALL
7	582 86 76-01	TRANSMISSION GEARBOX ALUM DD
8	588 07 75-01	BOLT 1/4-20 X 1-13/16 SHEAR
9	586 60 72-02	IMPELLER STEEL SNOW 479

NOTE: All component dimensions given in U.S. inches. 1 inch = 25.4 mm
IMPORTANT: Use only Original Equipment Manufacturer (O.E.M.) replacement parts.
Failure to do so could be hazardous, damage your snow thrower and void your warranty.

REPAIR PARTS

AUGER HOUSING / IMPELLER ASSEMBLY

SNOW THROWER - MODEL NO. ST 224 P (96193012203), PRODUCT NO. 961 93 01-22

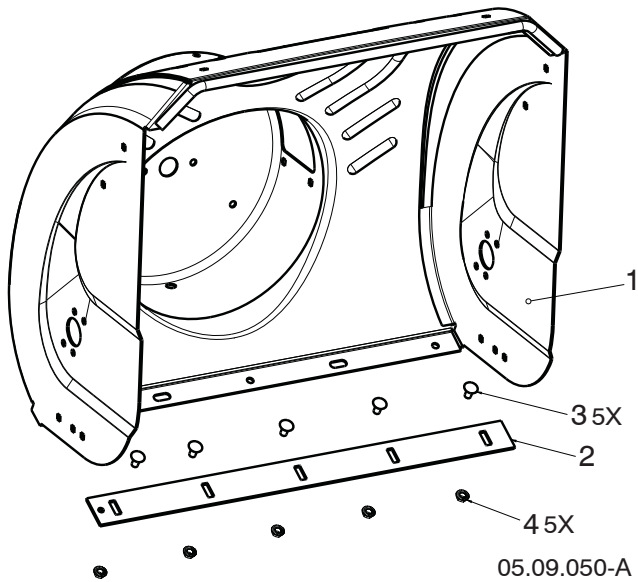

KEY NO.	PART NO.	DESCRIPTION
1	581 70 83-90	AUGER HOUSING
2	532 40 78-25	SCRAPER BAR
3	872 27 05-05	CARRIAGE BOLT 5/16-18 X .625 GR5
4	532 15 53-77	NUT 5/16-18

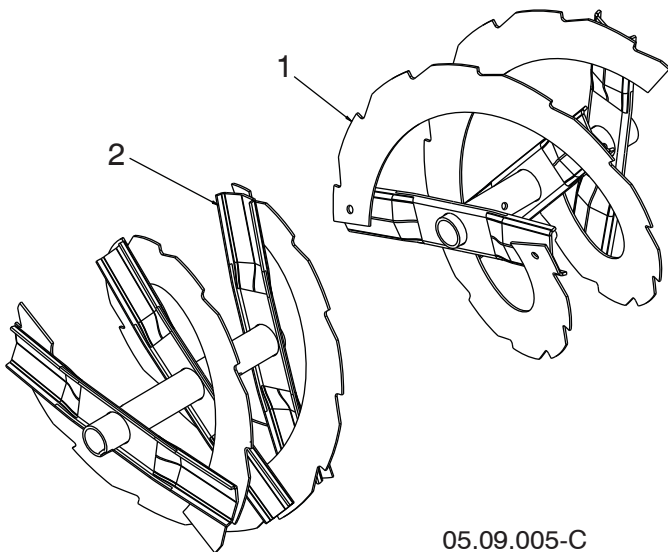

KEY NO.	PART NO.	DESCRIPTION
1	587 19 10-01	AUGER WELD RIB LH 24
2	585 54 42-01	AUGER WELD RIB RH 24

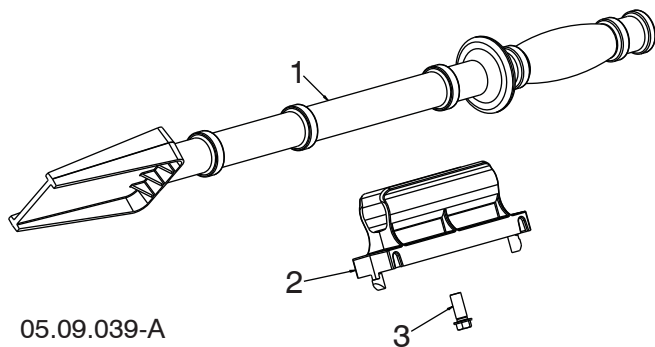

KEY NO.	PART NO.	DESCRIPTION
1	532 19 21-99	TOOL CLEANOUT
2	532 40 54-00	CLIP CLEANOUT TOOL
3	532 19 41-89	SCREW HEX WASHER 13-16 X 5/8

NOTE: All component dimensions given in U.S. inches. 1 inch = 25.4 mm
IMPORTANT: Use only Original Equipment Manufacturer (O.E.M.) replacement parts.
 Failure to do so could be hazardous, damage your snow thrower and void your warranty.

REPAIR PARTS

AUGER HOUSING / IMPELLER ASSEMBLY

SNOW THROWER - MODEL NO. ST 224 P (96193012203), PRODUCT NO. 961 93 01-22

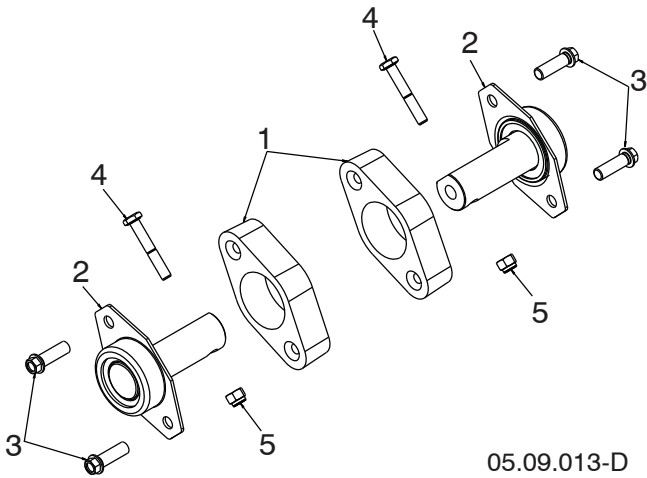

KEY NO.	PART NO.	DESCRIPTION
1	532 18 81-70	PLASTIC RETAINER
2	532 42 77-62	AUGER BALL BEARING
3	584 29 94-01	SCREW HI-LO 5/16-14 X 1.00 - BLK
4	874 78 04-26	BOLT SHEAR HEX HD 1/4-20
5	873 80 04-00	NUT 1/4-20

05.09.013-D

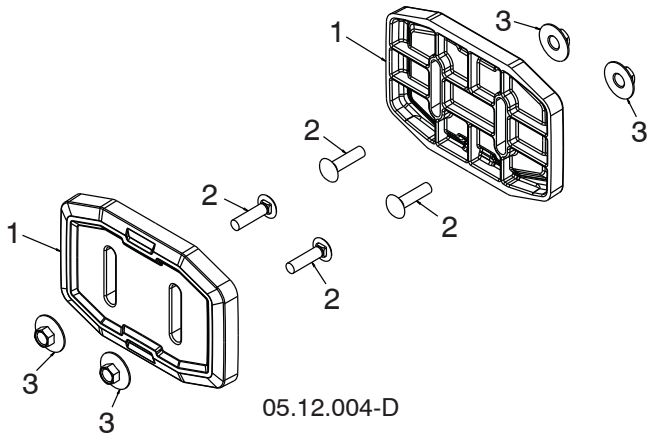

KEY NO.	PART NO.	DESCRIPTION
1	583 83 88-01	SKID SHOW UHMW
2	585 80 29-01	BOLT CARR BLK 5/16-18 X 1.25
3	585 80 28-01	NUT HEX 5/16-18 LRG FLG

05.12.004-D

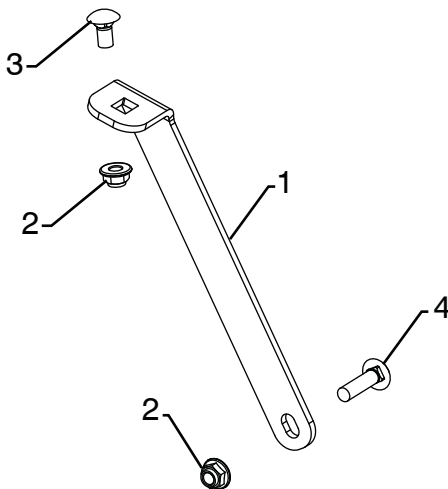

KEY NO.	PART NO.	DESCRIPTION
1	589 32 30-02	SUPPORT GEARBOX LS
2	585 69 13-01	NUT HEX FLG NYLOCK BLK 5/16-18
3	585 83 20-01	BOLT CARRIAGE BLK 5/16-18 X 5/8 BLK
4	872 11 05-10	BOLT CARRIAGE 5/16-18 X 1-1/4

05.09.049-A

NOTE: All component dimensions given in U.S. inches. 1 inch = 25.4 mm
IMPORTANT: Use only Original Equipment Manufacturer (O.E.M.) replacement parts. Failure to do so could be hazardous, damage your snow thrower and void your warranty.

REPAIR PARTS

CONTROL PANEL / DISCHARGE CHUTE

SNOW THROWER - MODEL NO. ST 224 P (96193012203), PRODUCT NO. 961 93 01-22

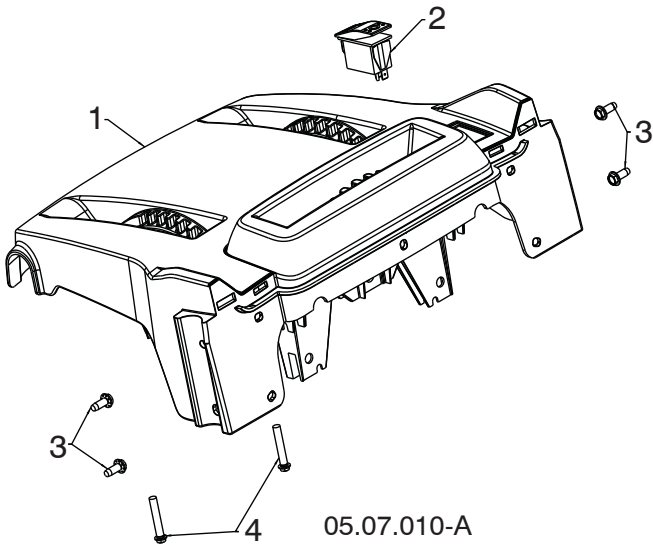

KEY NO.	PART NO.	DESCRIPTION
1	581 13 12-04	CONSOLE BASE MULTICONT GRAY-MS498
2	585 80 50-01	SWITCH GRIP HEATED BLACK
3	817 06 04-10	SCREW TA SEMI GIMLE 1/4-20 X .62
4	581 32 95-01	SCREW HEX WASHER HI-LO 13-16 X 1.50

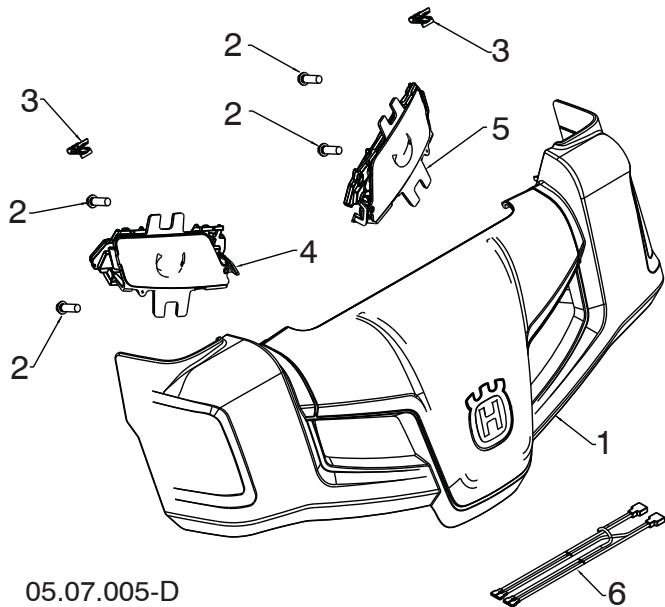

KEY NO.	PART NO.	DESCRIPTION
1	581 12 79-01	HUSQVARNA CONSOLE COVER ASM
2	532 19 41-89	SCREW HI-LO 13-16 X 5/8
3	581 92 87-01	CLIP PANEL
4	586 72 35-01	LIGHT ASM LED HUSQ RH
5	586 72 36-01	LIGHT ASM LED HUSQ LH
6	585 86 83-01	WIRE HARNESS LIGHT JUMPER

NOTE: All component dimensions given in U.S. inches. 1 inch = 25.4 mm
IMPORTANT: Use only Original Equipment Manufacturer (O.E.M.) replacement parts. Failure to do so could be hazardous, damage your snow thrower and void your warranty.

REPAIR PARTS

CONTROL PANEL / DISCHARGE CHUTE

SNOW THROWER - MODEL NO. ST 224 P (96193012203), PRODUCT NO. 961 93 01-22

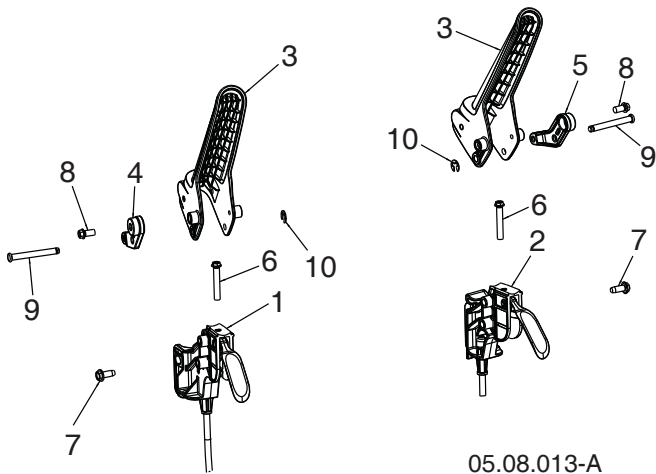

05.08.013-A

KEY NO.	PART NO.	DESCRIPTION
1	588 26 39-01	CABLE, POWER STEER - LHS
2	588 26 39-02	CABLE, POWER STEER - RHS
3	587 46 30-01	LEVER, CONTROL
4	587 73 97-01	LEVER, CABLE ARM - LHS
5	587 73 97-02	LEVER, CABLE ARM - RHS
6	581 32 95-01	SCREW HI-LO 13-16 X 1.50
7	817 06 04-10	SCREW 1/4-20 X .625
8	817 41 13-08	SCREW HI-LW 13-16 X .500
9	588 14 77-01	PIN, GROOVED
10	812 00 00-14	E-RING

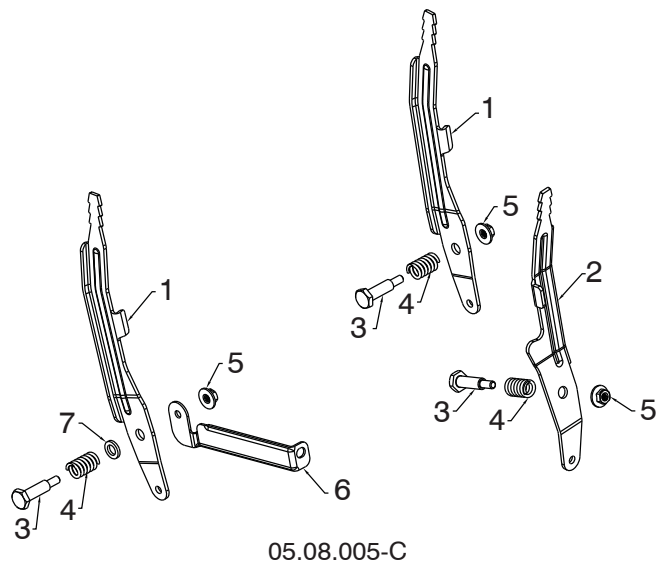

05.08.005-C

KEY NO.	PART NO.	DESCRIPTION
1	581 12 39-02	LEVER CONTROL SPEED/DEFL
2	581 24 16-02	LEVER CONTROL CHUTE ROT
3	581 32 97-01	BOLT SHOULDER 1/4-20
4	581 32 96-01	SPRING COMPRESSION
5	586 66 89-01	NUT FL LOCK 1/4-20
6	584 46 84-02	BRACE SUPPORT SPEED
7	587 03 13-01	WASHER .625 X .375 X .094 NYLON 6/6

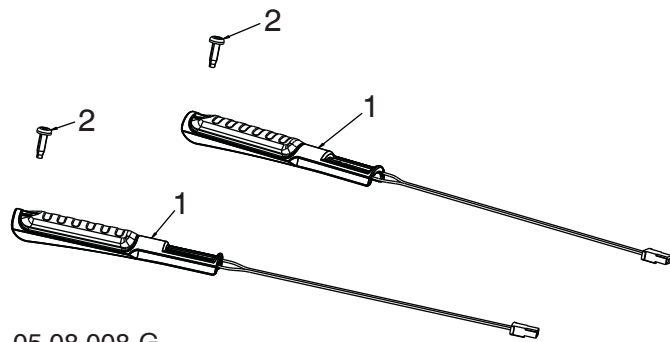

05.08.008-G

KEY NO.	PART NO.	DESCRIPTION
1	590 49 36-01	GRIP, HEATED, DSST SHO
2	532 44 22-50	SCREW PAN HD TORX 1/4-20 X .75

NOTE: All component dimensions given in U.S. inches. 1 inch = 25.4 mm
IMPORTANT: Use only Original Equipment Manufacturer (O.E.M.) replacement parts. Failure to do so could be hazardous, damage your snow thrower and void your warranty.

REPAIR PARTS

CONTROL PANEL / DISCHARGE CHUTE

SNOW THROWER - MODEL NO. ST 224 P (96193012203), PRODUCT NO. 961 93 01-22

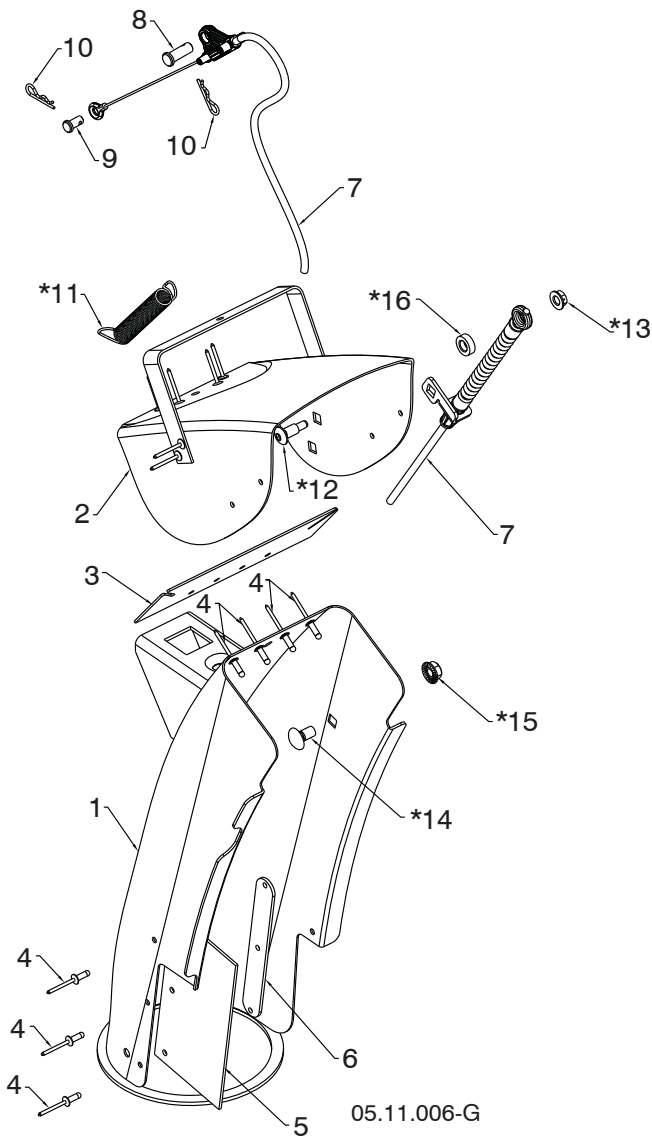

KEY NO.	PART NO.	DESCRIPTION
1	588 07 78-02	CHUTE WELDMENT ASSEMBLY (INCLUDES 1-6)
2	-----	RIVETED DEFLECTOR ASSEMBLY
3	-----	DEFLECTOR SEAL
4	-----	POP RIVET
5	-----	CHUTE SNOW SHIELD
6	-----	SHIELD STRAP RETAINER
7	590 58 70-01	CONTROL CHUTE DEFLECTOR BOWDEN
8	581 32 94-01	PIN CLEVIS 5/16 X .875
9	585 80 83-01	PIN CLEVIS 1/4 X .312
10	532 42 33-03	HAIRPIN RETAINER
*11	532 18 45-05	DEFLECTOR SPRING
*12	501 41 73-01	CARRIAGE BOLT 1/4-20 X .544
*13	585 69 14-01	NUT 1/4-20
*14	585 83 20-01	CARRIAGE BOLT 3/8-16 X .625
*15	873 97 05-00	NUT 5/16-18
*16	501 41 74-01	WASHER .362 X .625 X .205 NYLON

NOTE: ALL ITEMS MARKED WITH AN * ARE PROVIDED IN THE BAG OF ITEMS SHIPPED LOOSE WITH PRODUCT.

NOTE: All component dimensions given in U.S. inches. 1 inch = 25.4 mm
IMPORTANT: Use only Original Equipment Manufacturer (O.E.M.) replacement parts. Failure to do so could be hazardous, damage your snow thrower and void your warranty.

REPAIR PARTS

CONTROL PANEL / DISCHARGE CHUTE

SNOW THROWER - MODEL NO. ST 224 P (96193012203), PRODUCT NO. 961 93 01-22

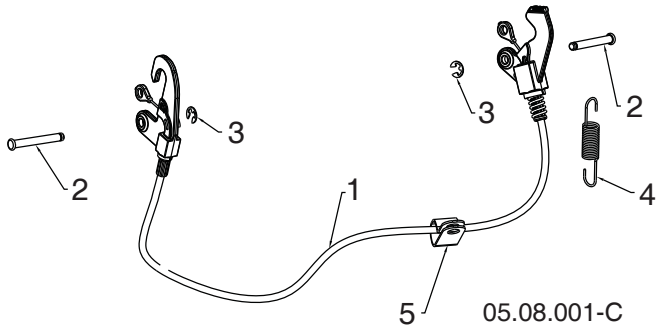

KEY NO.	PART NO.	DESCRIPTION
1	593 85 34-01	CABLE INTERLOCK
2	532 43 17-62	PIN GROOVED
3	812 00 00-14	E-RING
4	581 15 12-01	SPRING RETURN
5	532 19 79-91	CLIP CABLE BLACK

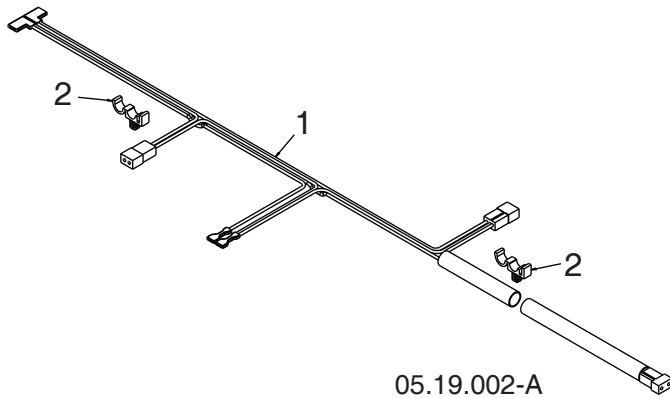

KEY NO.	PART NO.	DESCRIPTION
1	587 53 57-01	HARNESS WIRE LIGHTS & GRIPS
2	532 14 50-06	WIRE RETAINER

NOTE: All component dimensions given in U.S. inches. 1 inch = 25.4 mm
IMPORTANT: Use only Original Equipment Manufacturer (O.E.M.) replacement parts. Failure to do so could be hazardous, damage your snow thrower and void your warranty.

REPAIR PARTS

CONTROL PANEL / DISCHARGE CHUTE

SNOW THROWER - MODEL NO. **ST 224 P** (96193012203), PRODUCT NO. 961 93 01-22

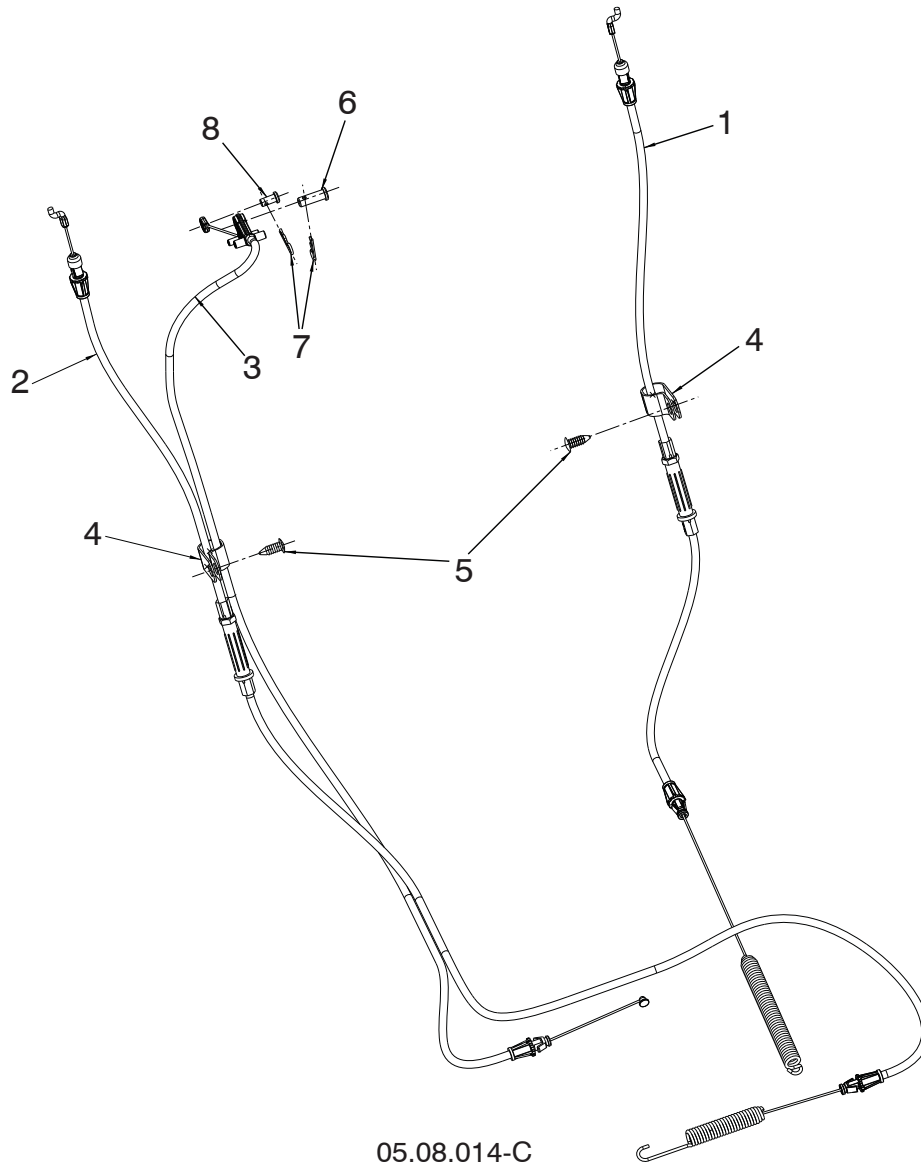

05.08.014-C

KEY NO.	PART NO.	DESCRIPTION
1	582 51 90-02	CABLE CONTROL DRIVE
2	588 11 38-02	CABLE CONTROL AUGER
3	588 12 23-01	CABLE CONTROL SPEED
4	532 19 79-91	CLIP CABLE
5	532 42 81-24	FASTENER PUSH .250
6	581 32 94-01	PIN CLEVIS 5/16
7	532 42 33-03	HAIRPIN
8	585 80 83-01	PIN CLEVIS 1/4

NOTE: All component dimensions given in U.S. inches. 1 inch = 25.4 mm
IMPORTANT: Use only Original Equipment Manufacturer (O.E.M.) replacement parts. Failure to do so could be hazardous, damage your snow thrower and void your warranty.

REPAIR PARTS

CONTROL PANEL / DISCHARGE CHUTE

SNOW THROWER - MODEL NO. ST 224 P (96193012203), PRODUCT NO. 961 93 01-22

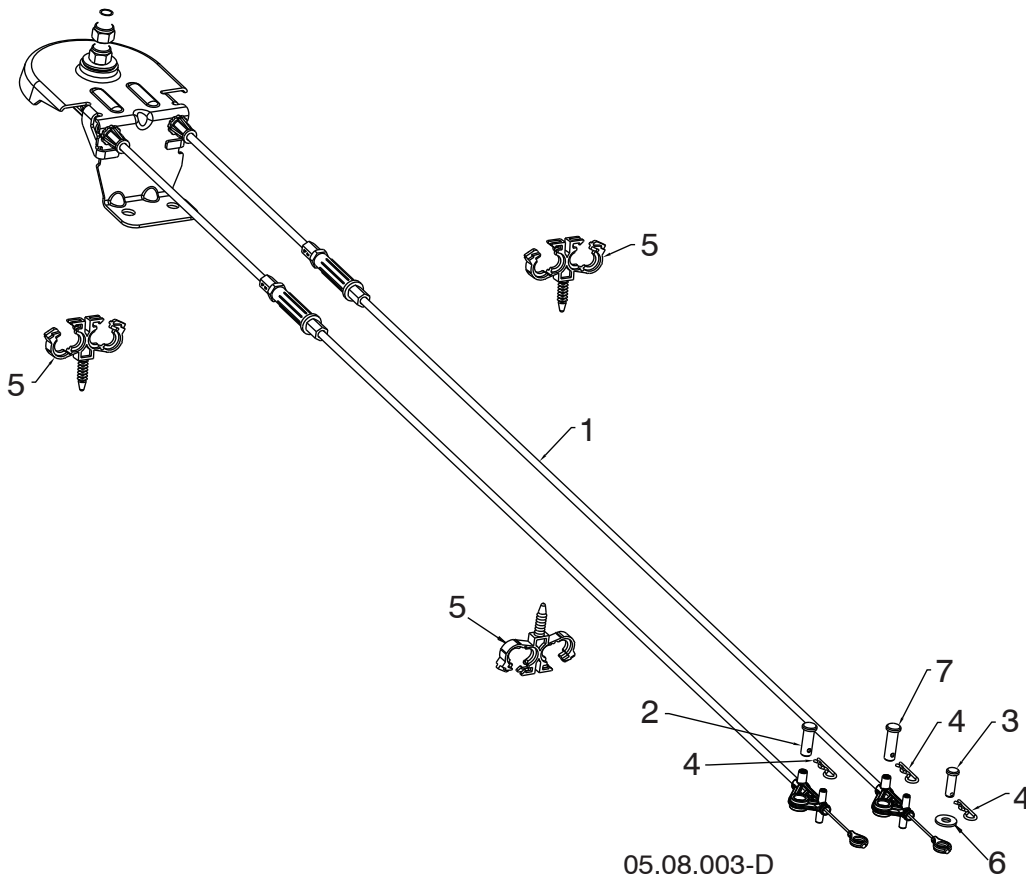

KEY NO.	PART NO.	DESCRIPTION
1	581 68 03-01	CABLE ROTATOR ASM
2	581 32 94-01	PIN CLEVIS 5/16 X 7/8
3	877 10 08-12	PIN CLEVIS 1/4 X 3/4
4	532 42 33-03	HAIRPIN SOFT ZINC
5	584 65 22-01	CLIP CONDUIT DOUBLE
6	586 68 21-01	WASHER
7	587 13 08-01	PIN CLEVIS 5/16 X 1

NOTE: All component dimensions given in U.S. inches. 1 inch = 25.4 mm
IMPORTANT: Use only Original Equipment Manufacturer (O.E.M.) replacement parts. Failure to do so could be hazardous, damage your snow thrower and void your warranty.

REPAIR PARTS

HANDLES

SNOW THROWER - MODEL NO. ST 224 P (96193012203), PRODUCT NO. 961 93 01-22

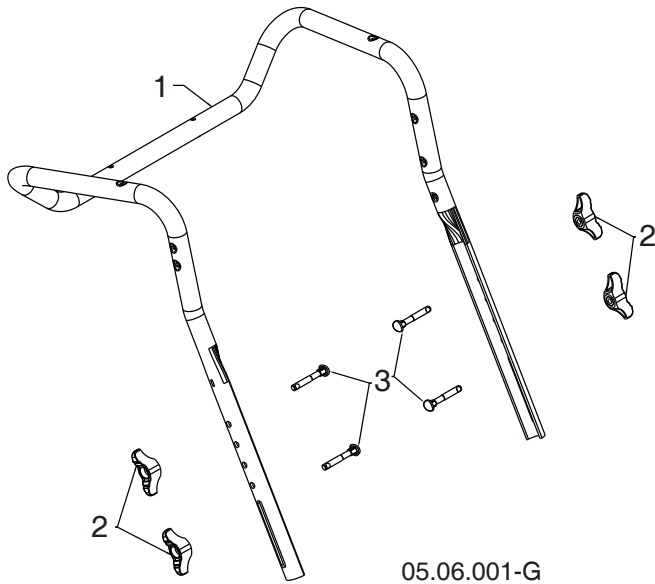

05.06.001-G

KEY NO.	PART NO.	DESCRIPTION
1	588 16 08-03	UPPER HANDLE
2	532 19 19-38	HANDLE KNOB STD BLACK
3	588 05 99-01	SCREW 5/16-18 X 2.25 CONCAVE HEAD WITH PATCH

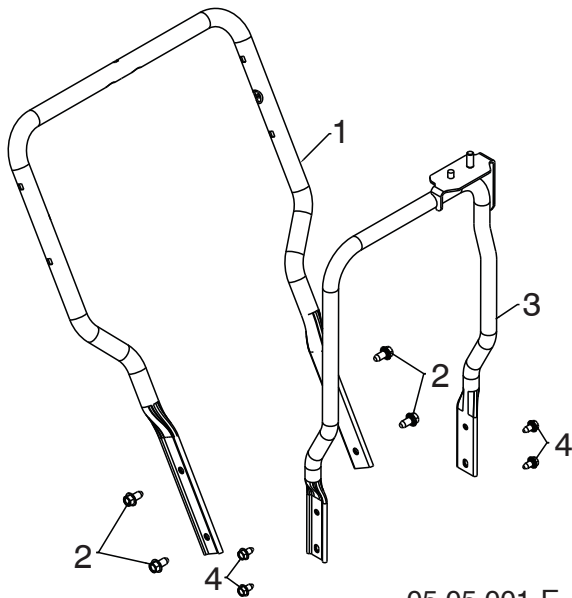

05.05.001-E

KEY NO.	PART NO.	DESCRIPTION
1	588 67 21-03	LOWER HANDLE
2	817 00 06-12	SCREW HEX WASH HD 3/8-16 X .75
3	589 26 45-04	CHUTE ROTATOR SUPPORT ASM
4	817 00 05-10	BOLT HEX 5/16-18

NOTE: All component dimensions given in U.S. inches. 1 inch = 25.4 mm
IMPORTANT: Use only Original Equipment Manufacturer (O.E.M.) replacement parts.
 Failure to do so could be hazardous, damage your snow thrower and void your warranty.

REPAIR PARTS

DRIVE

SNOW THROWER - MODEL NO. ST 224 P (96193012203), PRODUCT NO. 961 93 01-22

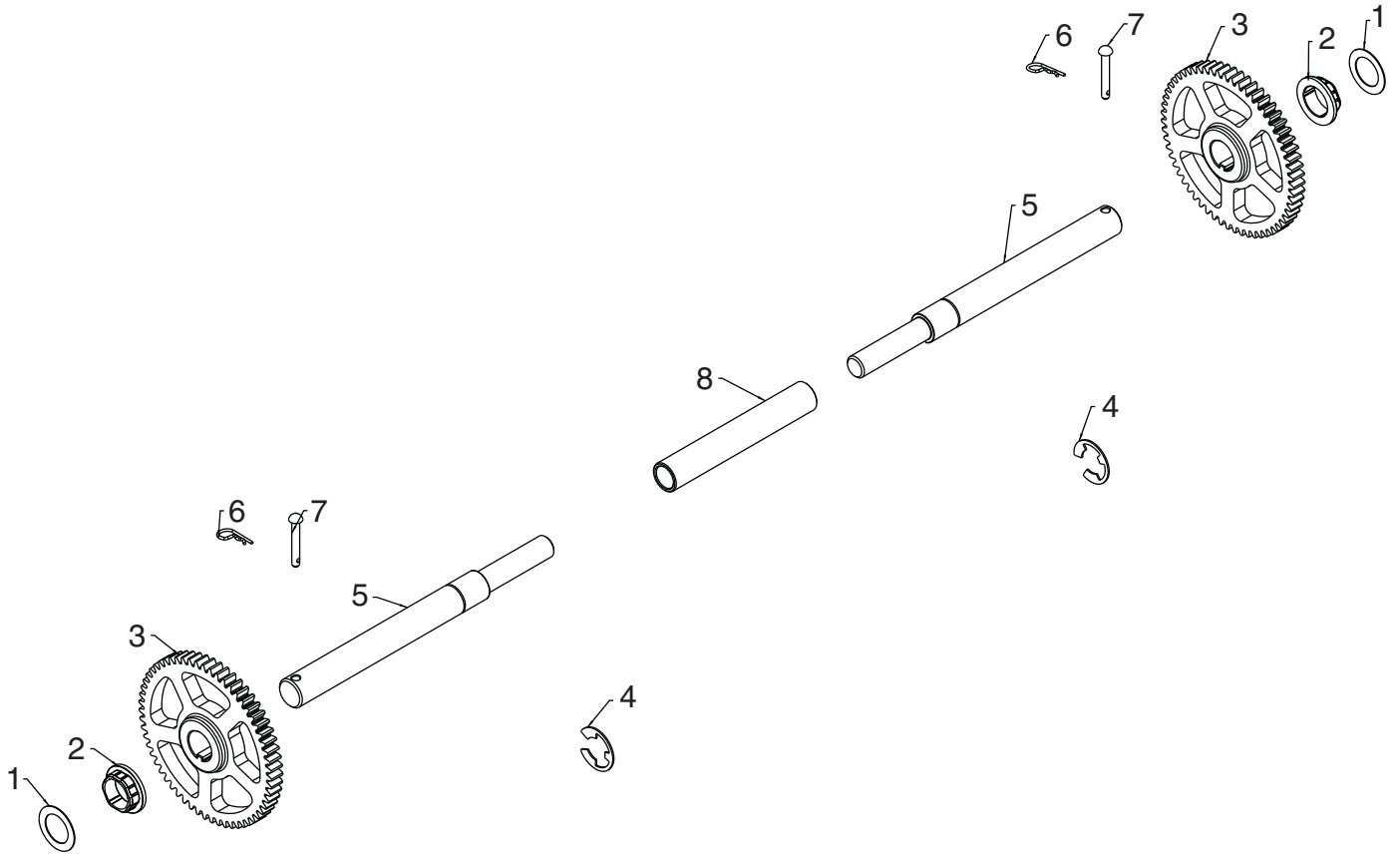

05.03.002-B

KEY NO.	PART NO.	DESCRIPTION
1	532 44 49-49	WASHER 1.00
2	587 97 89-01	BUSHING HEX 1 SHAFT
3	588 51 86-01	GEAR 59T DRIVEN
4	812 00 00-53	RETAINING RING
5	580 75 26-01	AXLE SHAFT SPLIT
6	532 12 47-88	RETAINER SPRING 1 ZINC
7	532 17 12-71	RIVET RD HD DRILLED 1/4 DIA
8	580 75 25-01	AXLE SLEEVE

NOTE: All component dimensions given in U.S. inches. 1 inch = 25.4 mm
IMPORTANT: Use only Original Equipment Manufacturer (O.E.M.) replacement parts.
 Failure to do so could be hazardous, damage your snow thrower and void your warranty.

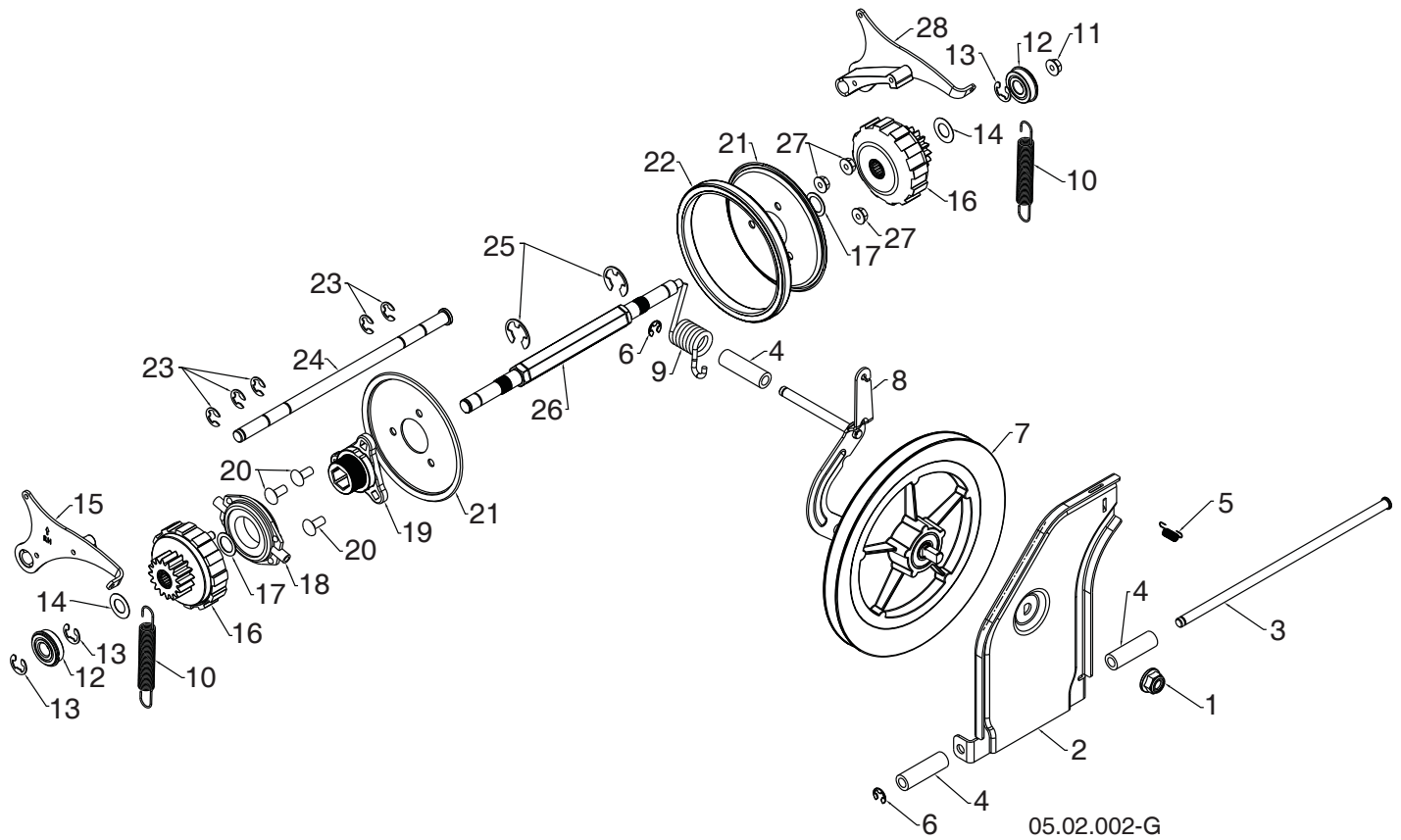

NOTE: All component dimensions given in U.S. inches. 1 inch = 25.4 mm
IMPORTANT: Use only Original Equipment Manufacturer (O.E.M.) replacement parts.
 Failure to do so could be hazardous, damage your snow thrower and void your warranty.

SNOW THROWER - MODEL NO. **ST 224 P** (96193012203), PRODUCT NO. 961 93 01-22

KEY NO.	PART NO.	DESCRIPTION
1	521 99 11-01	NUT HEX FLANGE LK 1/2-13
2	587 70 34-02	SWING PLATE FRICTION PULL
3	581 12 30-01	ROD TIP PLATE
4	581 73 27-01	SPACER DRIVE
5	532 19 38-85	LATCH SPRING
6	812 00 00-07	E-RING RETAINER
7	581 32 84-01	FRICTION DISC COMBO PULLEY
8	587 19 34-03	BRACKET YOKE ASSEMBLY
9	581 31 53-01	SPRING TORSION DRIVE
10	585 26 38-01	EXTENSION SPRING
11	585 69 15-01	NUT HEX FLANGE LOCK 5/16-18
12	580 75 62-01	BEARING 9/16 I.D. 1622-2RSNR
13	580 75 61-02	RETAINING RING 1622-2RSNR
14	580 75 13-01	WASHER FLAT .59 I.D. X 1.065 X 25 GA
15	580 75 66-01	PAWL ASM RH
16	580 75 60-01	GEAR ASM PLANETARY
17	580 75 63-01	WASHER FLAT .6875 I.D. X 1.00 X 21 GA
18	532 17 53-44	TRUNNION BEARING ASM
19	581 09 09-01	HUB RUBBER WHEEL
20	872 11 05-06	BOLT CARRIAGE 5/16-18 X .75
21	581 09 10-02	PLATE RUBBER WHEEL
22	581 09 11-01	RING RUBBER WHEEL
23	586 64 43-01	E-RING
24	580 75 51-01	ROD PAWL
25	812 00 00-22	E-RING
26	580 75 24-01	SHAFT REDUCTION PWR STR
27	532 75 11-53	NUT HEX FLANGE LK 5/16-18
28	580 75 67-01	PAWL ASM LH

NOTE: All component dimensions given in U.S. inches. 1 inch = 25.4 mm
IMPORTANT: Use only Original Equipment Manufacturer (O.E.M.) replacement parts.
 Failure to do so could be hazardous, damage your snow thrower and void your warranty.

REPAIR PARTS

CHASSIS / ENGINE / PULLEYS

SNOW THROWER - MODEL NO. ST 224 P (96193012203), PRODUCT NO. 961 93 01-22

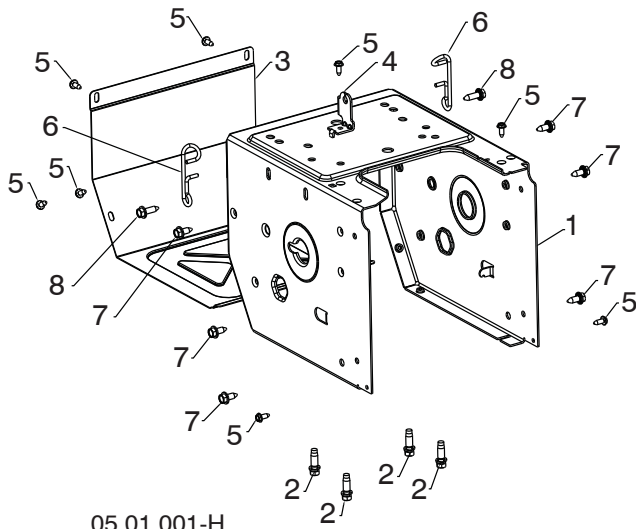

05.01.001-H

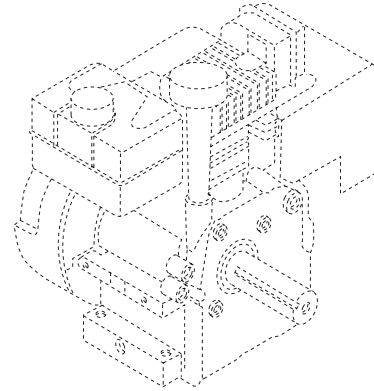

KEY NO.	PART NO.	DESCRIPTION
--	590 21 86-03	COMPLETE LCT ENGINE PW2HK18650178E
1	589 26 47-05	FRAME
2	532 15 04-06	ENGINE BOLT 3/8-16 X 1.280 DOGPOINT
3	580 83 95-05	FRAME COVER
4	501 06 04-03	SHIFTER BRACKET
5	582 90 69-01	SCREW HEX WASHER 1/4-20 X .625
6	588 95 45-01	WIREFORM SUPPORT CABLE
7	532 42 88-67	BOLT HEXHD WASHER 5/16-18 X .750
8	585 21 75-01	BOLT HEXHD WASHER 5/16-18 X 1.000

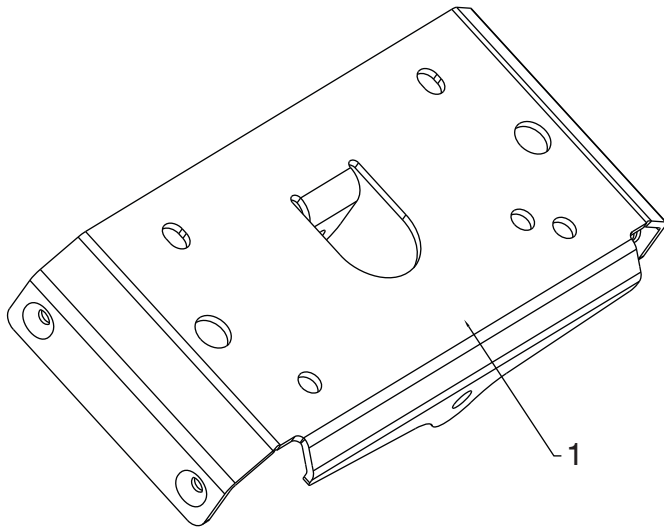

05.01.002-A

KEY NO.	PART NO.	DESCRIPTION
1	583 94 05-02	SMALL MOUNTING PLATE

NOTE: All component dimensions given in U.S. inches. 1 inch = 25.4 mm
IMPORTANT: Use only Original Equipment Manufacturer (O.E.M.) replacement parts. Failure to do so could be hazardous, damage your snow thrower and void your warranty.

REPAIR PARTS

CHASSIS / ENGINE / PULLEYS

SNOW THROWER - MODEL NO. ST 224 P (96193012203), PRODUCT NO. 961 93 01-22

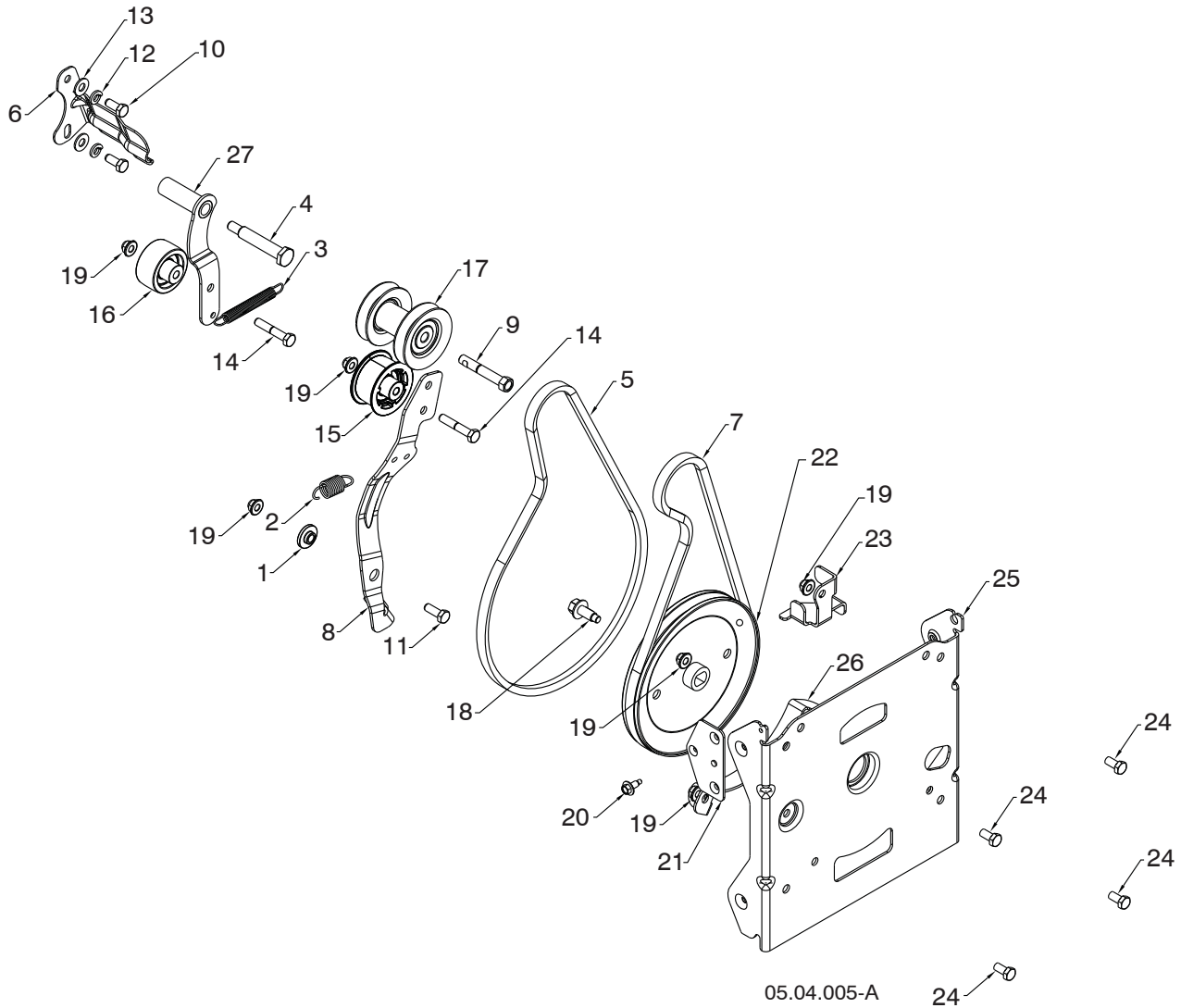

05.04.005-A

KEY NO.	PART NO.	DESCRIPTION	KEY NO.	PART NO.	DESCRIPTION
1	587 34 37-01	BUSHING BRAKE ARM	16	586 88 02-01	PULLEY IDLER 2.0 O/ SPACER
2	587 03 12-01	SPRING RETURN IDLER ARM	17	587 89 37-03	PULLEY ASM IMPELLER / DRIVE
3	580 75 30-01	SPRING RETURN IDLER ARM	18	583 81 49-01	SCREW FLANGE HEAD 3/8-16
4	581 41 38-01	BOLT SHOULDER 5/16-24 X 2.15	19	532 42 79-42	NUT NYLOK FLANGE 5/16-18
5	584 21 61-02	BELT DRIVE 4L X 38.19	20	585 51 78-01	SCREW 1/4-20 X .65 W/DOG POINT
6	588 49 28-02	BRACKET BELT KEEPER 007	21	590 04 46-02	BRACKET NUT BZP
7	501 81 82-01	BELT IMPELLER LOW CRANK	22	590 69 92-01	PULLEY IMPELLER DD 4L
8	580 83 11-06	ARM IDLER AUTO PH .676	23	587 58 72-02	GUIDE LOWER AUGER BELT 479
9	582 38 84-01	BOLT ENGINE PULLEY	24	532 16 31-83	BOLT HXHD 5/16-18 X 5/8
10	874 61 05-12	CAPSCREW HEXHD 5/16-24 X .75 GR5	25	581 59 25-02	BRACKET AUG HOUSING INTER 479
11	874 76 05-14	BOLT HEXHD 5/16-18 X .875	26	581 63 20-02	BRACKET BELT KEEPER LOWER 479
12	810 04 05-00	LOCKWASHER 5/16 SPLIT HVY	27	581 33 82-03	ARM IDLER DRIVE
13	819 11 12-16	WASHER 11/32 X 3/4 X 16GA			
14	874 76 05-28	BOLT HXHD 5/16-18 X 1.75			
15	581 14 14-01	PULLEY IDLER 2.0 WITH SPACER			

NOTE: All component dimensions given in U.S. inches. 1 inch = 25.4 mm
IMPORTANT: Use only Original Equipment Manufacturer (O.E.M.) replacement parts. Failure to do so could be hazardous, damage your snow thrower and void your warranty.

REPAIR PARTS

CHASSIS / ENGINE / PULLEYS

SNOW THROWER - MODEL NO. ST 224 P (96193012203), PRODUCT NO. 961 93 01-22

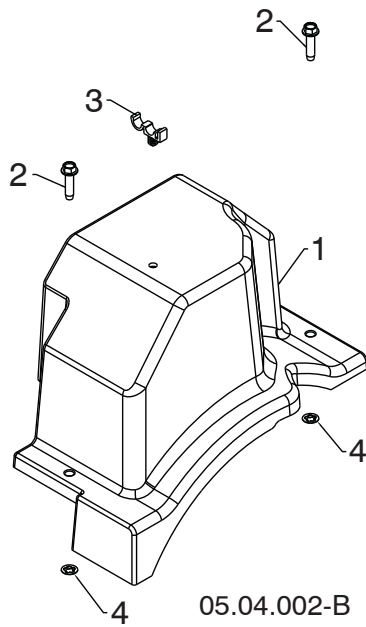

KEY NO.	PART NO.	DESCRIPTION
1	587 10 54-01	BELT COVER BLACK ASSEMBLY (INCLUDES 2 & 4)
2	-----	BOLT HEX WSH THDRL 1/4-20 X 1
3	532 14 50-06	CABLE GUIDE
4	-----	PALNUT 1/4 IN

NOTE: All component dimensions given in U.S. inches. 1 inch = 25.4 mm
IMPORTANT: Use only Original Equipment Manufacturer (O.E.M.) replacement parts. Failure to do so could be hazardous, damage your snow thrower and void your warranty.

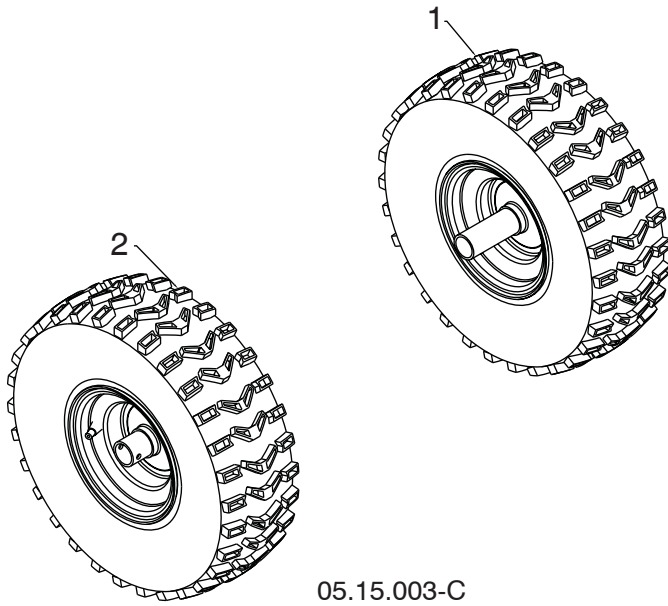

KEY NO.	PART NO.	DESCRIPTION
1	586 71 04-01	WHEEL 15X5.00 NPS LH 1.00 K478
2	586 71 03-01	WHEEL 15X5.00 NPS RH 1.00 K478

05.15.003-C

NOTE: All component dimensions given in U.S. inches. 1 inch = 25.4 mm
IMPORTANT: Use only Original Equipment Manufacturer (O.E.M.) replacement parts.
 Failure to do so could be hazardous, damage your snow thrower and void your warranty.

REPAIR PARTS

BAG OF PARTS

SNOW THROWER - MODEL NO. ST 224 P (96193012203), PRODUCT NO. 961 93 01-22

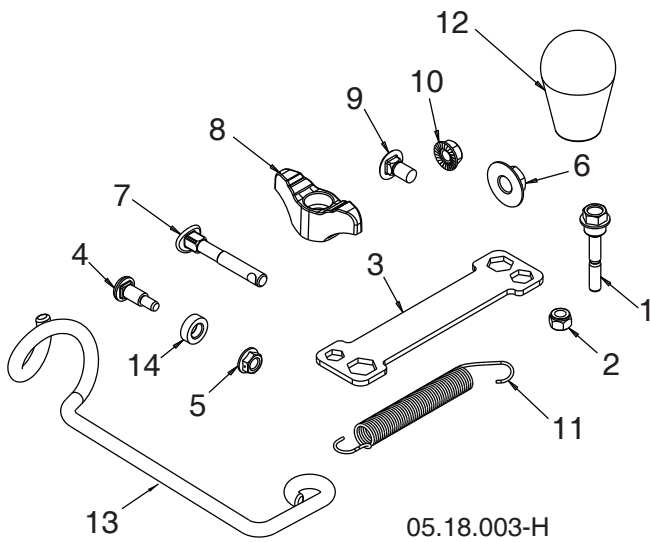

KEY NO.	PART NO.	DESCRIPTION
1	588 07 75-01	BOLT 1/4-20 X 1.81
2	873 80 04-00	NUT NYLOCK 1/4-20
3	532 42 91-12	WRENCH
4	501 41 73-01	BOLT SHOULDER
5	585 69 14-01	NUT HEX FL 1/4-20 CTR
6	585 69 10-01	NUT NYLOCK 3/8-16
7	588 05 99-01	BOLT 5/16-18 X 2.25 CONCAVE
8	532 19 19-38	KNOB 5/16-18 TWO-WING
9	585 83 20-01	BOLT 5/16-18 X .625
10	873 97 05-00	NUT SERR FL LOCK 5/16-18
11	532 18 45-05	SPRING DEFLECT CHUTE
12	581 69 75-01	KNOB SOFT TOUCH SLOTTED
13	581 89 73-01	SUPPORT ROTATION CABLE
14	501 41 74-01	WASHER NYLON
NI	588 07 76-03	KIT REPLACEMENT BAG OF PARTS

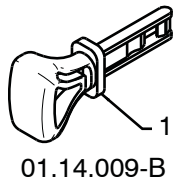

KEY NO.	PART NO.	DESCRIPTION
1	532 44 30-59	SAFETY IGNITION KEY KIT

01.14.009-B

NOTE: All component dimensions given in U.S. inches. 1 inch = 25.4 mm
IMPORTANT: Use only Original Equipment Manufacturer (O.E.M.) replacement parts.
 Failure to do so could be hazardous, damage your snow thrower and void your warranty.



1



3



2



4

KEY NO.	PART NO.	DESCRIPTION
1	532 18 40-45	DECAL AUGER
2	590 81 22-01	DECAL CHUTE
3	532 19 96-83	DECAL AUGER SAFETY
4	532 18 40-28	DECAL BELT GUIDE

05.16.001-A

NOTE: All component dimensions given in U.S. inches. 1 inch = 25.4 mm
IMPORTANT: Use only Original Equipment Manufacturer (O.E.M.) replacement parts. Failure to do so could be hazardous, damage your snow thrower and void your warranty.

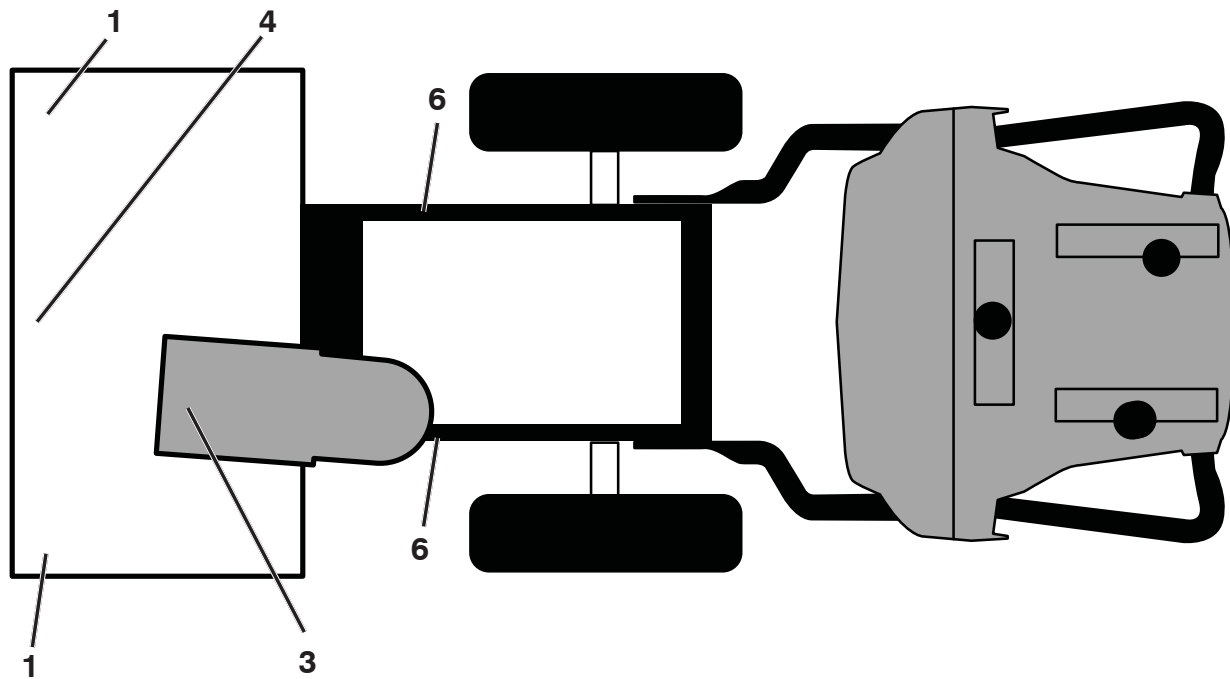

**KEY PART
NO. NO.**

DESCRIPTION

1	532 19 96-83	DECAL, DANGER
3	590 81 22-01	DECAL, DANGER, DEFLECTOR
4	532 18 40-45	DECAL, DANGER
6	532 18 40-28	DECAL
--	115 99 57-49	OPERATOR'S MANUAL, ENGLISH, FRENCH, SPANISH
--	532 42 86-77	CROWN "H" (NOT SHOWN)
--	590 69 72-01	DECAL, ENG. RECOIL (NOT SHOWN)
--	532 17 45-72	DECAL, CANADA IGNITION (NOT SHOWN)
--	588 62 63-01	DECAL, AUGER HSQ (NOT SHOWN)

NOTE: All component dimensions given in U.S. inches. 1 inch = 25.4 mm
IMPORTANT: Use only Original Equipment Manufacturer (O.E.M.) replacement parts.
 Failure to do so could be hazardous, damage your snow thrower and void your warranty.

ENGINE, LCT

COMPLETE ENGINE-590218603

GEN II 136/179/208/254cc Snow Engines

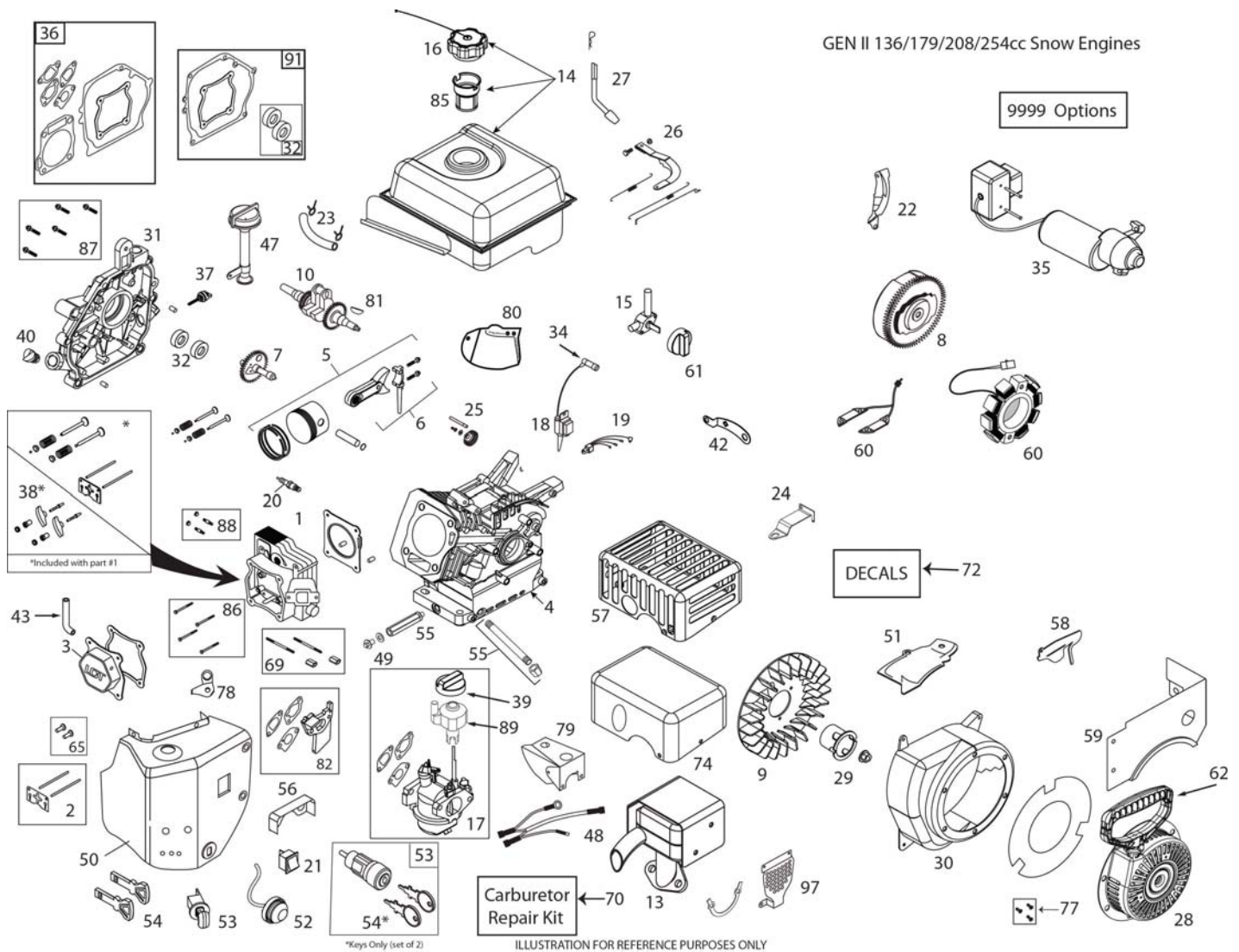

*Keys Only (set of 2) ILLUSTRATION FOR REFERENCE PURPOSES ONLY

KEY NO.	PART NO.	DESCRIPTION	KEY NO.	PART NO.	DESCRIPTION
1	532 42 05-78	CYLINDER HEAD ASSEMBLY (INCL. GASKET)	16	532 42 49-42	FUEL TANK CAP - BLACK CLICK STYLE (VENTED)
2	532 42 05-79	PUSH ROD & PLATE KIT (W/ VALVE COVER GSKT)	17	587 14 79-01	CARBURETOR (W/IDLE SPEED CONTROL - W/GSKTS)
3	532 42 05-80	VALVE COVER (INCL. GASKET)	18	532 44 39-34	IGNITION COIL (CDI)
5	532 42 05-82	PISTON & ROD ASSEMBLY	20	532 42 49-39	SPARK PLUG
7	532 42 05-84	CAMSHAFT - MCR	22	585 77 24-01	SHIELD - FLYWHEEL
8	595 01 24-01	FLYWHEEL - ELECTRIC START W/ 6 MAGNETS	23	532 43 21-44	FUEL HOSE KIT
9	532 42 05-86	COOLING FAN - FLYWHEEL	24	532 42 92-59	SPEED CONTROL BRACKET (FIXED)
10	532 44 66-42	CRANKSHAFT	25	532 42 96-46	GOVERNOR GEAR ASSEMBLY
13	587 73 78-01	MUFFLER ASSEMBLY	26	581 76 87-01	GOVERNOR ARM & LINK KIT
14	532 43 65-64	FUEL TANK (2.7L BLACK W/ PLASTIC CAP)	27	532 42 06-02	GOVERNOR ARM PADDLE
15	532 42 92-34	FUEL TANK ON/OFF VALVE (PETCOCK)	28	532 43 69-67	RECOIL STARTER ASSY (ROUND-BLACK)
			29	532 43 69-68	STARTER CUP (USE WITH ROUND STYLE STARTER)

NOTE: All component dimensions given in U.S. inches. 1 inch = 25.4 mm
IMPORTANT: Use only Original Equipment Manufacturer (O.E.M.) replacement parts. Failure to do so could be hazardous, damage your snow thrower and void your warranty.

ENGINE, LCT

COMPLETE ENGINE-590218603

KEY NO.	PART NO.	DESCRIPTION	KEY NO.	PART NO.	DESCRIPTION
30	581 19 20-01	BLOWER HOUSING - BLACK ELECTRIC START	59	532 43 65-62	FUEL TANK SKIRT
31	581 00 73-01	CRANKCASE COVER ASSY (PRESS-IN TYPE HOFT) (INCL. GASKET)	60	532 44 38-93	60 WATT AC CHARGING COIL
32	532 42 95-99	OIL SEAL KIT (2 PCS)	61	532 43 27-52	FUEL CONTROL KNOB (RED)
34	532 43 69-66	SPARK PLUG BOOT	65	581 37 28-01	TAPPET KIT (SET OF 2)
35	532 43 64-66	120V ELECTRIC STARTER (SIDE MOUNT)	69	532 42 49-51	CARBURETOR STUDS & COUPLING KIT-SNOW
36	532 42 96-01	ENGINE GASKET KIT	70	580 35 36-02	CARBURETOR REPAIR KIT
37	532 42 09-61	SMALL BLACK OIL DIPSTICK (PLASTIC)	72	587 15 22-01	LABEL KIT
38	532 42 96-91	ROCKERARMKIT (INCL. GASKET)	74	587 82 11-01	MUFFLER HEAT SHIELD COVER
39	532 42 92-24	CHOKE CONTROL KNOB (GEN II RED)	77	532 43 26-88	RECOIL BOLT KIT (3 BOLTS PER KIT)
40	532 42 95-98	NON-REMOVABLE PLASTIC PLUG	78	581 45 93-01	BREATHER TUBE BRACKET
43	580 35 34-01	BREATHER TUBE	79		SEE REF 58 N/A PART OF REF 58, ALL ONE PART
47	581 00 72-01	HIGH OIL-FILL TUBE/DIPSTICK (PRESS-IN TYPE)	80		SEE REF 58 N/A PART OF REF 58, ALL ONE PART
48	595 01 25-01	WIRE HARNESS (W/O ON/OFF SWITCH)	81	585 29 72-01	WOODRUFF FLYWHEEL KEYS (5-PACK)
49	532 43 54-95	OIL DRAIN PLUG W/WASHER	82	585 02 05-03	CARBURETOR SPACER KIT
50	595 01 26-01	HEATER BOX (W/O ON/OFF SWITCH)	85	586 32 56-01	FUEL TANK STRAINER
51	532 43 71-19	SHIELD - CYLINDER	86	586 32 73-02	CYLINDER HEAD BOLT KIT (4)
52	532 42 49-49	PRIMER BULB WITH HOSE	87	586 32 69-01	CC COVER BOLT KIT (6)
53	532 42 49-54	SAFETY KEY SWITCH -SNOW (INCL. KEYS)	88	586 32 68-01	MUFFLER MTG STUD KIT (2)
54	532 44 30-59	KEY SET - RED (2) (SNOW)	91	587 52 57-01	CRANKSHAFT GASKET KIT
55	532 43 26-86	OIL DRAIN TUBE-SNOW	97	589 75 26-01	MUFFLER MANIFOLD SHIELD
56		SEE REF 58 N/A PART OF REF 58, ALL ONE PIECE	9999	586 32 62-01	HIGH ALTITUDE JET (>6,000 FEET)
58	595 01 27-01	GOV AND CARB SHIELD - COMPOSITE (ALSO REPLS 56, 79, 80)	9999	579 80 64-01	BOLT KIT - BLOWER HSG- HEATER BOX-TANK SKIRT
			9999	590 92 08-01	STARTER SWITCH BOX SCREWS

NOTE: All component dimensions given in U.S. inches. 1 inch = 25.4 mm
IMPORTANT: Use only Original Equipment Manufacturer (O.E.M.) replacement parts.
 Failure to do so could be hazardous, damage your snow thrower and void your warranty.