

ILLUSTRATED PARTS LIST

MODEL NUMBER ST 330

PRODUCT NUMBER 961 93 01-28

MFG. ID. NUMBER 96193012800

REPAIR PARTS

AUGER HOUSING / IMPELLER ASSEMBLY

SNOW THROWER - MODEL NO. ST 330 (96193012800), PRODUCT NO. 961 93 01-28

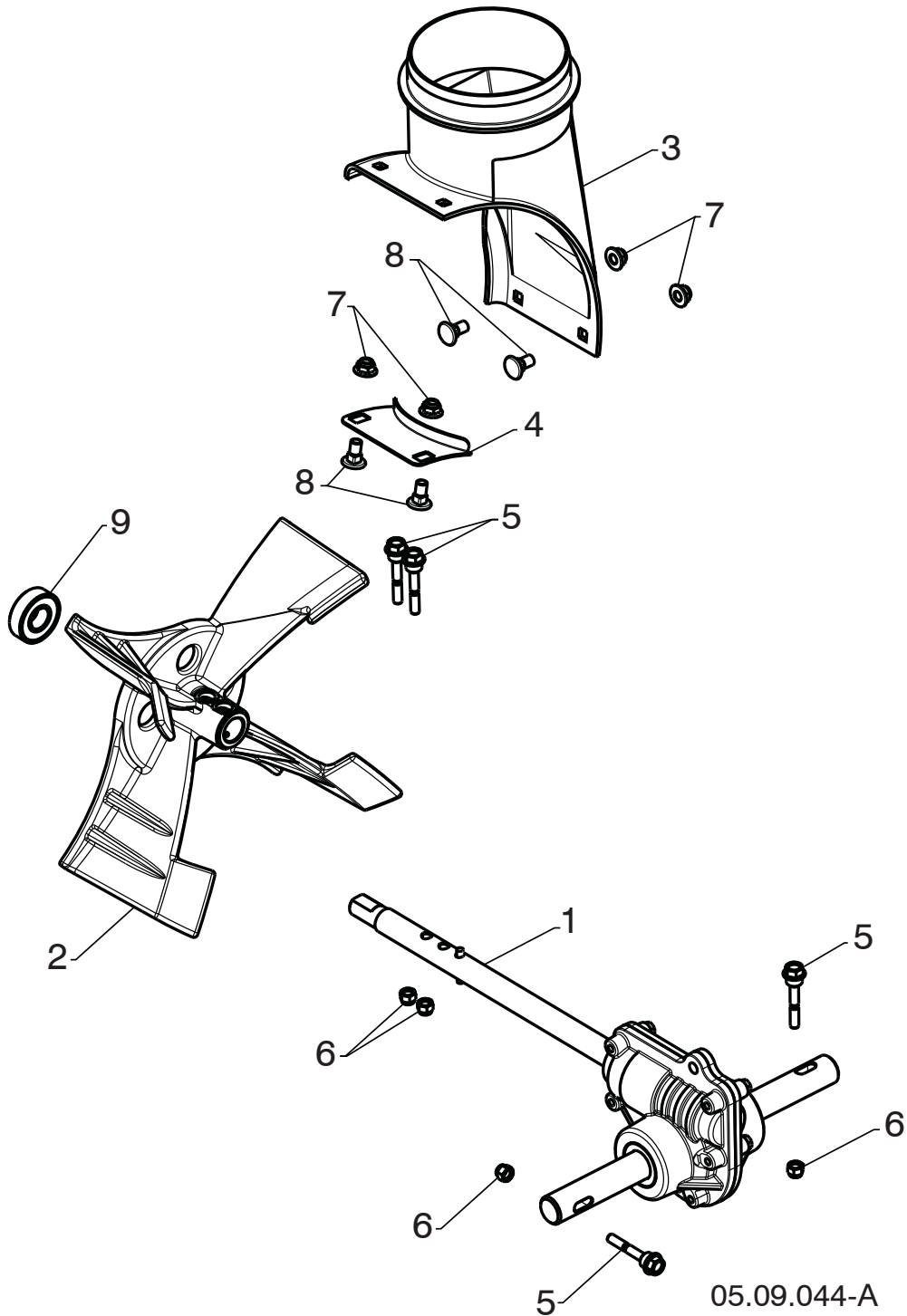

NOTE: All component dimensions given in U.S. inches. 1 inch = 25.4 mm
IMPORTANT: Use only Original Equipment Manufacturer (O.E.M.) replacement parts.
Failure to do so could be hazardous, damage your snow thrower and void your warranty.

REPAIR PARTS**AUGER HOUSING / IMPELLER ASSEMBLY****SNOW THROWER - MODEL NO. ST 330 (96193012800), PRODUCT NO. 961 93 01-28**

KEY NO.	PART NO.	DESCRIPTION
1	582 86 77-01	AUGER TRANSMISSION CAST IRON
2	585 19 83-03	IMPELLER
3	585 05 69-01	CHUTE DISCHARGE BASE
4	532 18 40-95	BRACKET CORNER DISCHARGE BASE
5	588 07 75-01	BOLT SHEAR 1/4-20
6	873 80 04-00	NUT NYLOCK 1/4-20
7	585 69 13-01	NUT FLANGE NYLOCK 5/16-18
8	585 69 12-01	BOLT CARRIAGE WAFER HEAD 5/16-18 X 5/8
9	532 19 87-91	BEARING BALL

NOTE: All component dimensions given in U.S. inches. 1 inch = 25.4 mm
IMPORTANT: Use only Original Equipment Manufacturer (O.E.M.) replacement parts.
Failure to do so could be hazardous, damage your snow thrower and void your warranty.

REPAIR PARTS

AUGER HOUSING / IMPELLER ASSEMBLY

SNOW THROWER - MODEL NO. ST 330 (96193012800), PRODUCT NO. 961 93 01-28

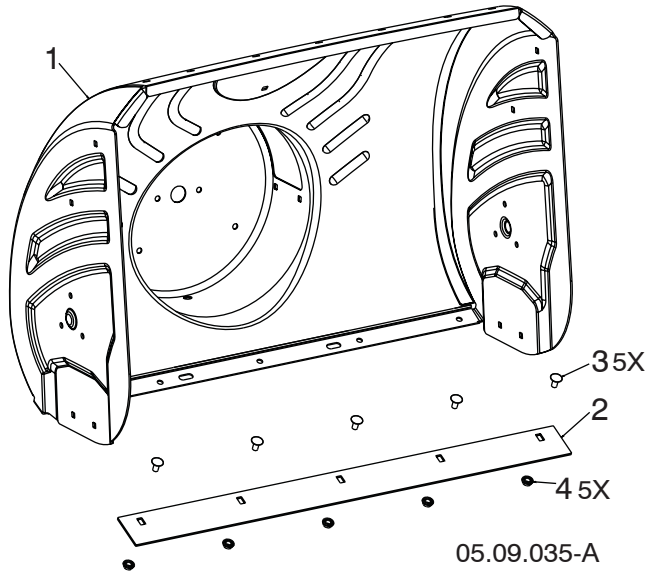

KEY NO.	PART NO.	DESCRIPTION
1	588 61 02-40	AUGER HOUSING 30 LS
2	585 04 85-02	SHAVE PLATE 30 LS MS428
3	872 27 05-05	BOLT CARRIAGE 5/16-18 X .625
4	532 15 53-77	NUT 5/16-18 HEX TOP LOCK

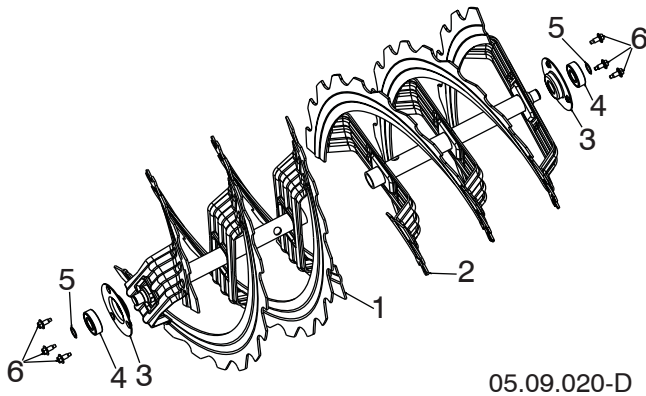

KEY NO.	PART NO.	DESCRIPTION
1	581 97 05-03	AUGER RIBBON 30 RH LS
2	581 97 06-03	AUGER RIBBON 30 LH LS
3	580 85 55-01	SUPPORT AUGER BEARING
4	532 43 76-22	BEARING IDLER 6203
5	812 00 00-28	RING RETAINING #5100-52
6	585 51 78-01	SCREW 1/4-20 X .65 W/DOG POINT

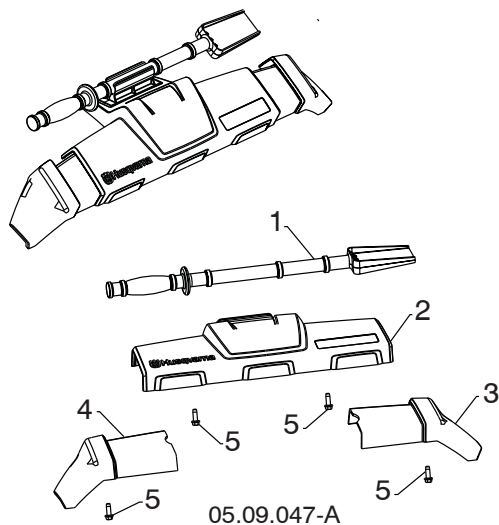

KEY NO.	PART NO.	DESCRIPTION
1	532 19 21-99	TOOL CLEANOUT
2	586 41 48-02	AUGER FRONT TRIM ASM
3	586 33 03-02	TRIM AUGER HOUSING WING RH
4	586 33 04-02	TRIM AUGER HOUSING WING LH
5	817 67 04-12	SCREW HEX WASHER TRI-LOBE 1/4-20 X 3/4

NOTE: All component dimensions given in U.S. inches. 1 inch = 25.4 mm
IMPORTANT: Use only Original Equipment Manufacturer (O.E.M.) replacement parts. Failure to do so could be hazardous, damage your snow thrower and void your warranty.

REPAIR PARTS

AUGER HOUSING / IMPELLER ASSEMBLY

SNOW THROWER - MODEL NO. ST 330 (96193012800), PRODUCT NO. 961 93 01-28

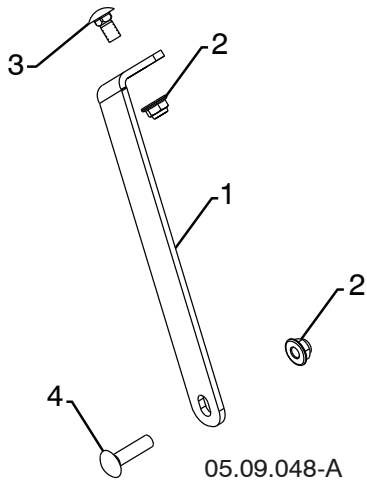

KEY NO.	PART NO.	DESCRIPTION
1	585 10 90-04	SUPPORT GEARBOX LS
2	585 69 13-01	NUT HEX FLG NYLOCK BLK 5/16-18
3	585 83 20-01	BOLT CARRIAGE BLK 5/16-18 X 5/8 BLK
4	872 11 05-10	BOLT CARRIAGE 5/16-18 X 1-1/4

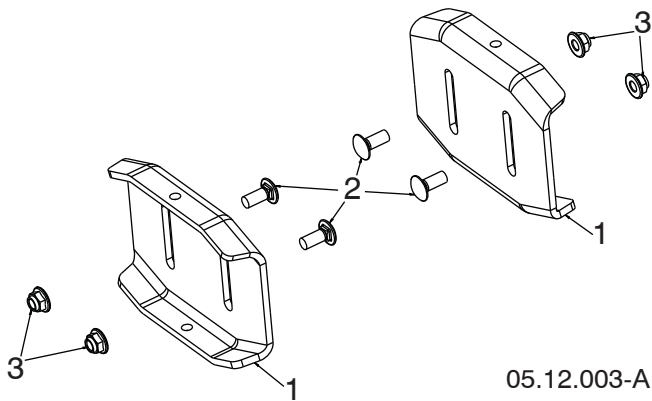

KEY NO.	PART NO.	DESCRIPTION
1	532 40 78-34	SKID PLATE
2	585 69 17-01	BOLT CARRIAGE 5/16-18 X .750 - BLK
3	585 69 13-01	NUT FLANGE NYLOCK 5/16-18 - BLK

NOTE: All component dimensions given in U.S. inches. 1 inch = 25.4 mm
IMPORTANT: Use only Original Equipment Manufacturer (O.E.M.) replacement parts. Failure to do so could be hazardous, damage your snow thrower and void your warranty.

REPAIR PARTS

CONTROL PANEL / DISCHARGE CHUTE

SNOW THROWER - MODEL NO. ST 330 (96193012800), PRODUCT NO. 961 93 01-28

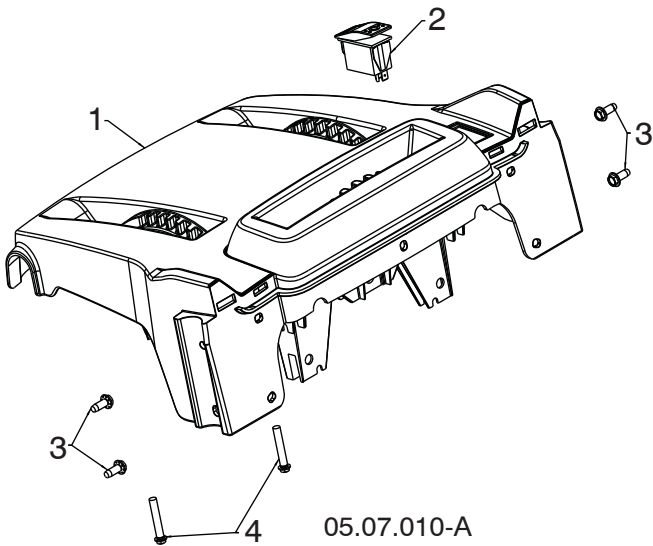

KEY NO.	PART NO.	DESCRIPTION
1	581131204	CONSOLE BASE MULTICONT W/SWITCH
2	585805001	SWITCH GRIP HEATED BLACK
3	17060410	SCREW TA SEMI GIMLE 1/4-20 X .62
4	581329501	SCREW HEX WASHER 13-16 X 1.50

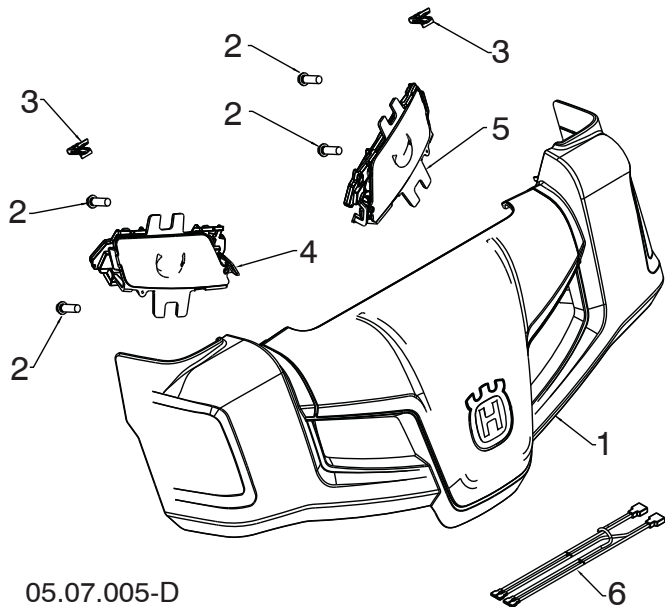

KEY NO.	PART NO.	DESCRIPTION
1	581 12 79-01	HUSQVARNA CONSOLE COVER ASM
2	532 19 41-89	SCREW HI-LO 13-16 X 5/8
3	581 92 87-01	CLIP PANEL
4	586 72 35-01	LIGHT ASM LED HUSQ RH
5	586 72 36-01	LIGHT ASM LED HUSQ LH
6	585 86 83-01	WIRE HARNESS LIGHT JUMPER

NOTE: All component dimensions given in U.S. inches. 1 inch = 25.4 mm
IMPORTANT: Use only Original Equipment Manufacturer (O.E.M.) replacement parts. Failure to do so could be hazardous, damage your snow thrower and void your warranty.

REPAIR PARTS

CONTROL PANEL / DISCHARGE CHUTE

SNOW THROWER - MODEL NO. ST 330 (96193012800), PRODUCT NO. 961 93 01-28

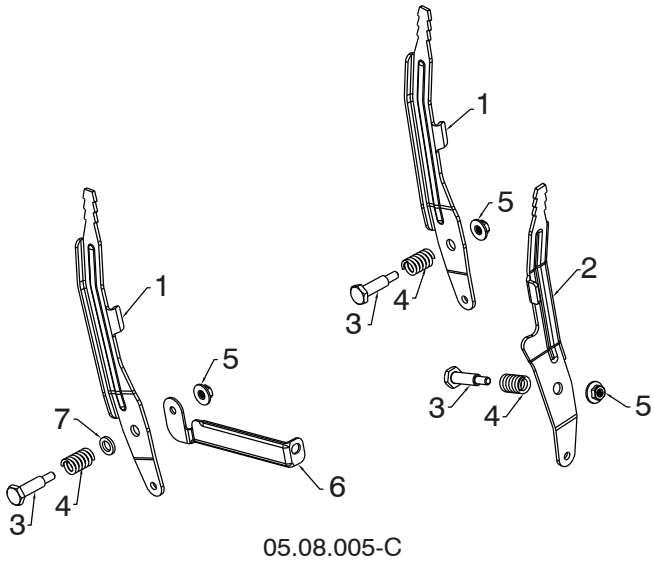

KEY NO.	PART NO.	DESCRIPTION
1	581 12 39-02	LEVER CONTROL SPEED/DEFL
2	581 24 16-02	LEVER CONTROL CHUTE ROT
3	581 32 97-01	BOLT SHOULDER 1/4-20
4	581 32 96-01	SPRING COMPRESSION
5	586 66 89-01	NUT FL LOCK 1/4-20
6	584 46 84-02	BRACE SUPPORT SPEED
7	587 03 13-01	WASHER .625 X .375 X .094 NYLON 6/6

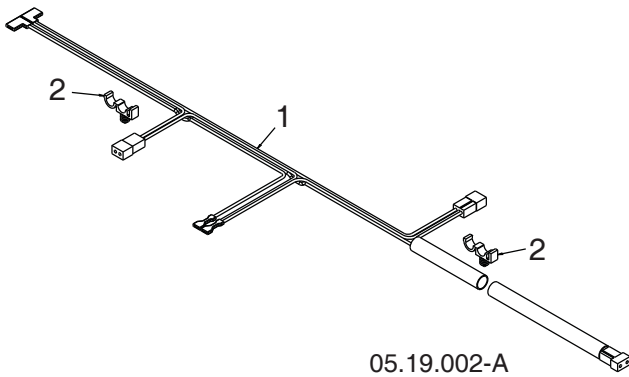

KEY NO.	PART NO.	DESCRIPTION
1	587 53 57-01	HARNES WIRE LIGHTS & GRIPS
2	532 14 50-06	WIRE RETAINER

NOTE: All component dimensions given in U.S. inches. 1 inch = 25.4 mm
IMPORTANT: Use only Original Equipment Manufacturer (O.E.M.) replacement parts. Failure to do so could be hazardous, damage your snow thrower and void your warranty.

REPAIR PARTS

CONTROL PANEL / DISCHARGE CHUTE

SNOW THROWER - MODEL NO. ST 330 (96193012800), PRODUCT NO. 961 93 01-28

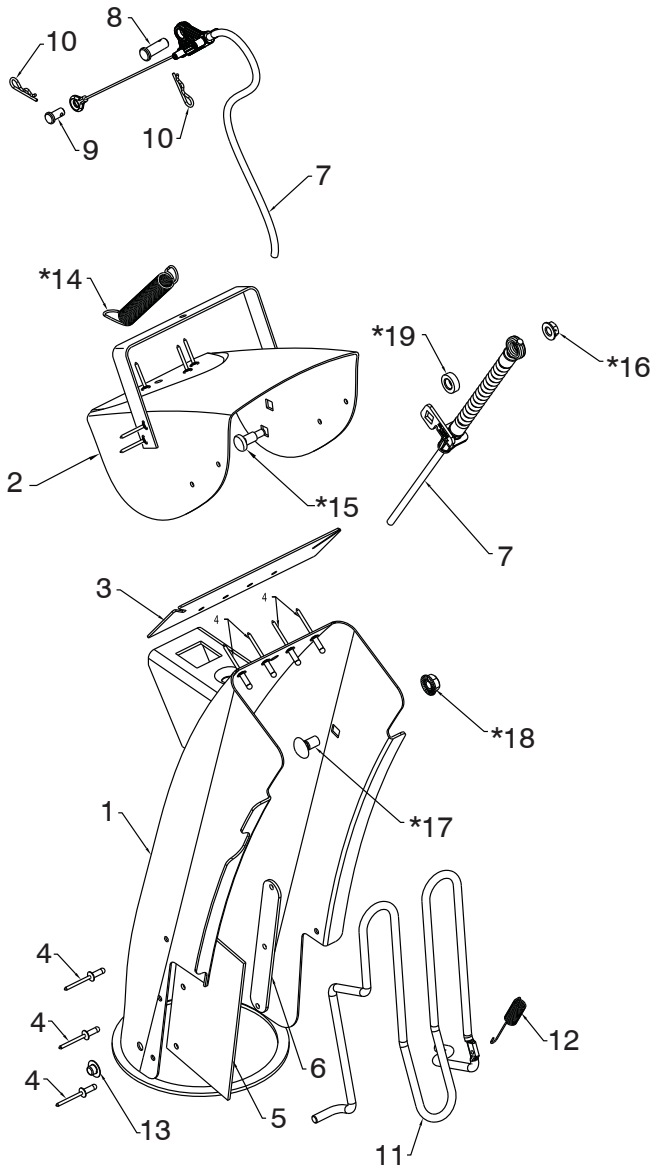

05.11.008-G

KEY NO.	PART NO.	DESCRIPTION
1	588 07 78-02	CHUTE WELDMENT (INCLUDES 1, 2, 3, 4, 5, 6)
2	-----	DEFLECTOR RIVET
3	-----	DEFLECTOR SEAL
4	-----	POP RIVET
5	-----	CHUTE SNOW SHIELD
6	-----	SHIELD STRAP RETAINER
7	590 58 70-01	CABLE ASM DEFLECTOR - BOWDEN
8	581 32 94-01	PIN CLEVIS 5/16 X .875
9	585 80 83-01	PIN CLEVIS 1/4 X .312
10	532 42 33-03	HAIRPIN RETAINER
11	532 43 55-82	CHUTE GUARD
12	532 43 56-16	GUARD RETURN SPRING
13	532 05 93-49	PUSH NUT
*14	532 18 45-05	DEFLECTOR SPRING
*15	501 41 73-01	CARRIAGE BOLT 1/4-20 X .544
*16	585 69 14-01	NUT 1/4-20
*17	585 83 20-01	CARRIAGE BOLT 3/8-16 X .625
*18	873 97 05-00	NUT 5/16-18
*19	501 41 74-01	WASHER .326 X .625 X .205 NYLON

NOTE: ALL ITEMS MARKED WITH AN * ARE PROVIDED IN THE BAG OF ITEMS SHIPPED LOOSE WITH PRODUCT.

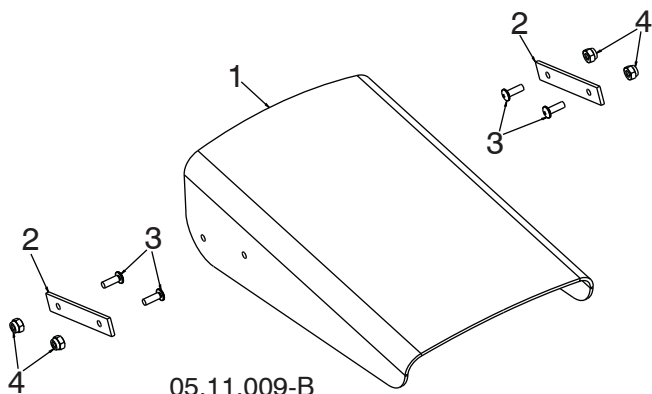

05.11.009-B

KEY NO.	PART NO.	DESCRIPTION
1	532 42 11-38	SHIELD DEFLECTOR
2	532 42 32-47	STRAP
3	586 11 80-01	SCREW MACHINE 8-32 X .50 - BLK
4	586 11 81-01	NUT HEX NYLOCK 8-32 - BLK

NOTE: All component dimensions given in U.S. inches. 1 inch = 25.4 mm
IMPORTANT: Use only Original Equipment Manufacturer (O.E.M.) replacement parts. Failure to do so could be hazardous, damage your snow thrower and void your warranty.

REPAIR PARTS

CONTROL PANEL / DISCHARGE CHUTE

SNOW THROWER - MODEL NO. ST 330 (96193012800), PRODUCT NO. 961 93 01-28

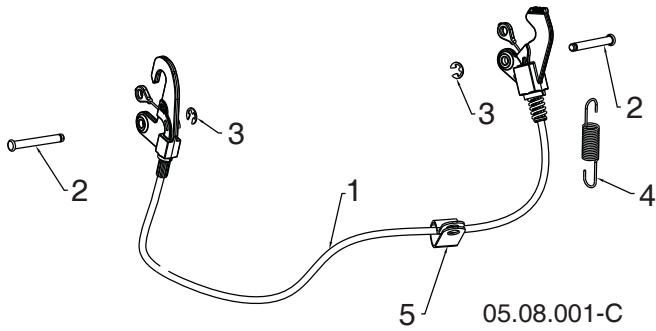

KEY NO.	PART NO.	DESCRIPTION
1	587 33 25-02	CABLE INTERLOCK
2	532 43 17-62	PIN GROOVED
3	812 00 00-14	E-RING
4	581 15 12-01	SPRING RETURN
5	532 19 79-91	CLIP CABLE BLACK

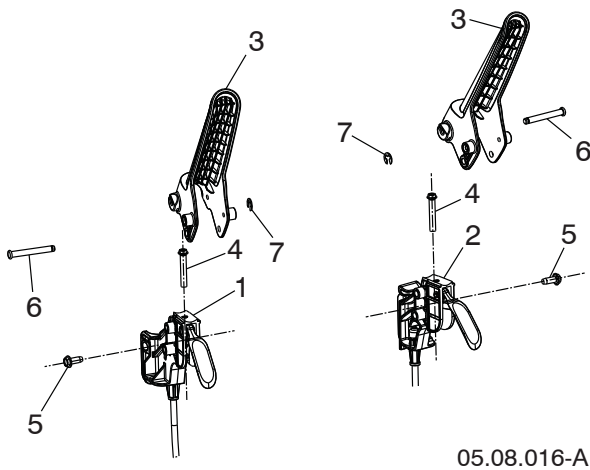

KEY NO.	PART NO.	DESCRIPTION
1	588 26 39-01	CABLE, POWER STEER - LHS
2	588 26 39-02	CABLE, POWER STEER - RHS
3	582 91 78-01	LEVER, CONTROL
4	581 32 95-01	SCREW HI-LOW 13-16 X 1.50
5	817 06 04-10	SCREW 1/4-20 X .625
6	532 43 17-62	PIN, GROOVED
7	812 00 00-14	E-RING

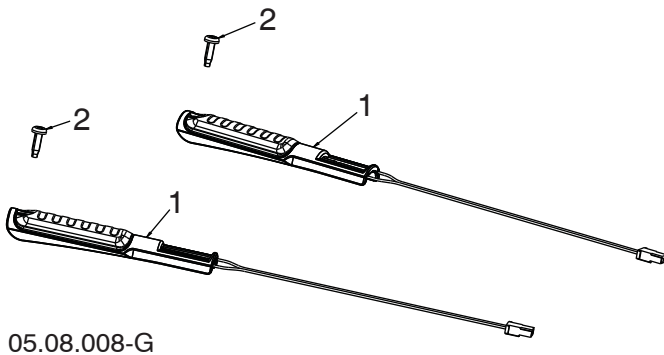

KEY NO.	PART NO.	DESCRIPTION
1	590 49 36-01	GRIP, HEATED, DSST SHO
2	532 44 22-50	SCREW PAN HD TORX 1/4-20 X .75

NOTE: All component dimensions given in U.S. inches. 1 inch = 25.4 mm
IMPORTANT: Use only Original Equipment Manufacturer (O.E.M.) replacement parts.
 Failure to do so could be hazardous, damage your snow thrower and void your warranty.

REPAIR PARTS

CONTROL PANEL / DISCHARGE CHUTE

SNOW THROWER - MODEL NO. ST 330 (96193012800), PRODUCT NO. 961 93 01-28

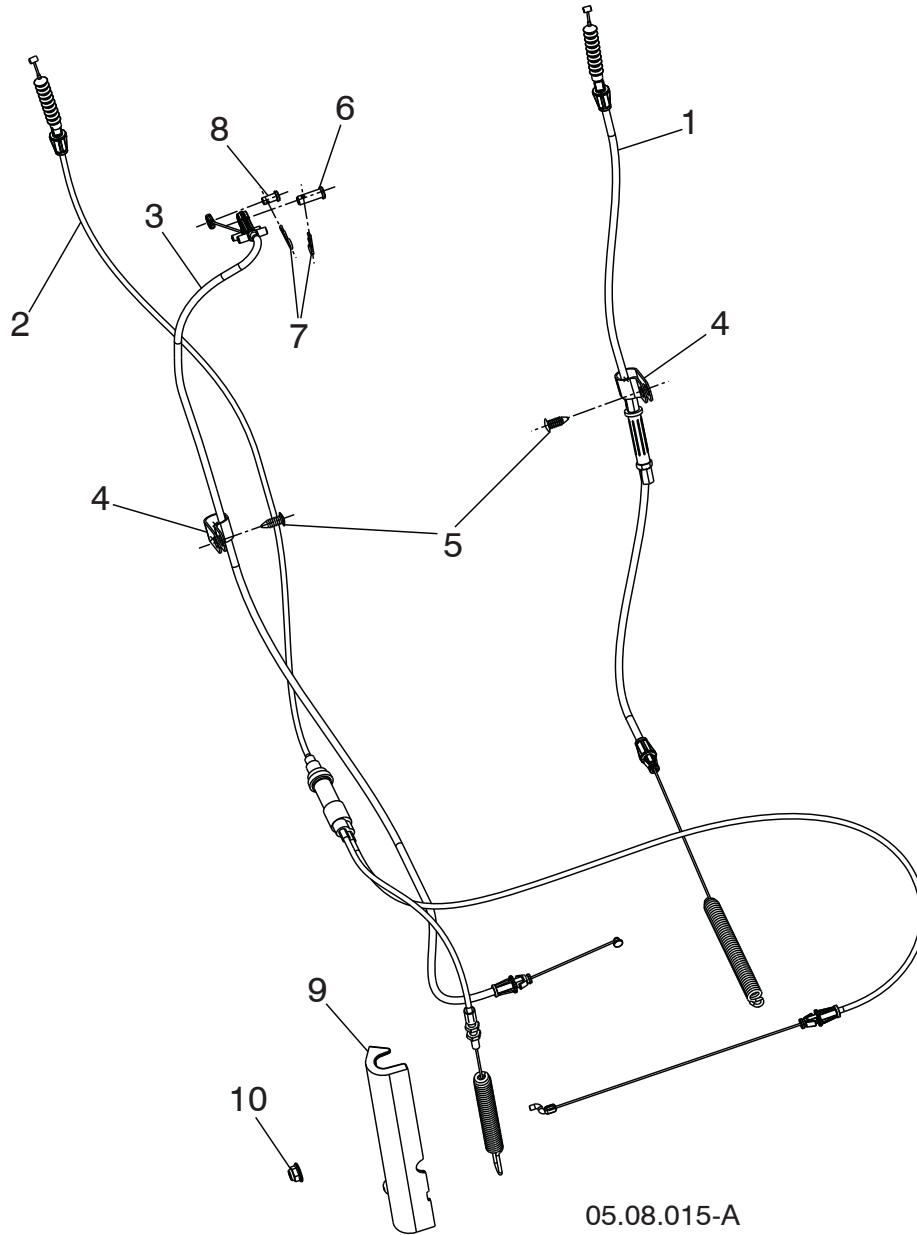

05.08.015-A

KEY NO.	PART NO.	DESCRIPTION
1	501 65 66-02	CABLE CONTROL DRIVE
2	579 76 36-01	CABLE CONTROL AUGER
3	588 12 23-01	CABLE CONTROL SPEED
4	532 19 79-91	CLIP CABLE
5	532 42 81-24	FASTENER PUSH .250
6	581 32 94-01	PIN CLEVIS 5/16
7	532 42 33-03	HAIRPIN
8	585 80 83-01	PIN CLEVIS 1/4
9	589 26 52-01	CABLE COVER
10	532 42 79-42	5/16-18 HEX NUT

NOTE: All component dimensions given in U.S. inches. 1 inch = 25.4 mm
IMPORTANT: Use only Original Equipment Manufacturer (O.E.M.) replacement parts. Failure to do so could be hazardous, damage your snow thrower and void your warranty.

REPAIR PARTS

CONTROL PANEL / DISCHARGE CHUTE

SNOW THROWER - MODEL NO. **ST 330** (96193012800), PRODUCT NO. 961 93 01-28

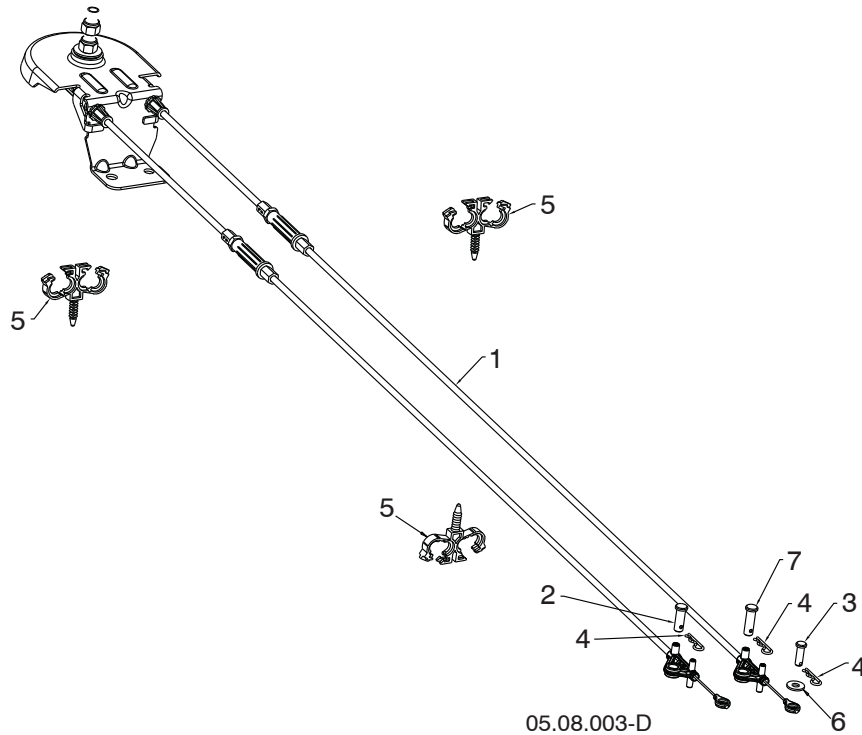

KEY NO.	PART NO.	DESCRIPTION
1	581 68 03-01	CABLE ROTATOR ASM
2	581 32 94-01	PIN CLEVIS 5/16 X 7/8
3	877 10 08-12	PIN CLEVIS 1/4 X 3/4
4	532 42 33-03	HAIRPIN SOFT ZINC
5	584 65 22-01	CLIP CONDUIT DOUBLE
6	586 68 21-01	WASHER
7	587 13 08-01	PIN CLEVIS 5/16 X 1

NOTE: All component dimensions given in U.S. inches. 1 inch = 25.4 mm
IMPORTANT: Use only Original Equipment Manufacturer (O.E.M.) replacement parts.
Failure to do so could be hazardous, damage your snow thrower and void your warranty.

REPAIR PARTS

HANDLES

SNOW THROWER - MODEL NO. ST 330 (96193012800), PRODUCT NO. 961 93 01-28

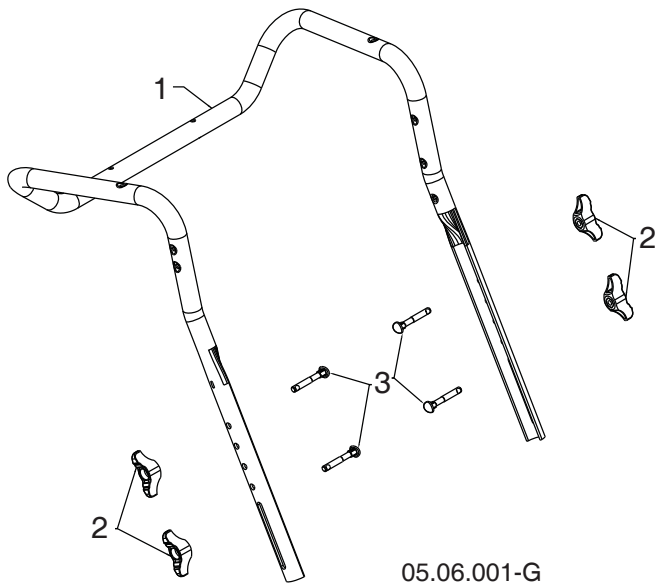

KEY NO.	PART NO.	DESCRIPTION
1	588 16 08-03	UPPER HANDLE
2	532 19 19-38	HANDLE KNOB STD BLACK
3	588 05 99-01	SCREW 5/16-18 X 2.25 CONCAVE HEAD WITH PATCH

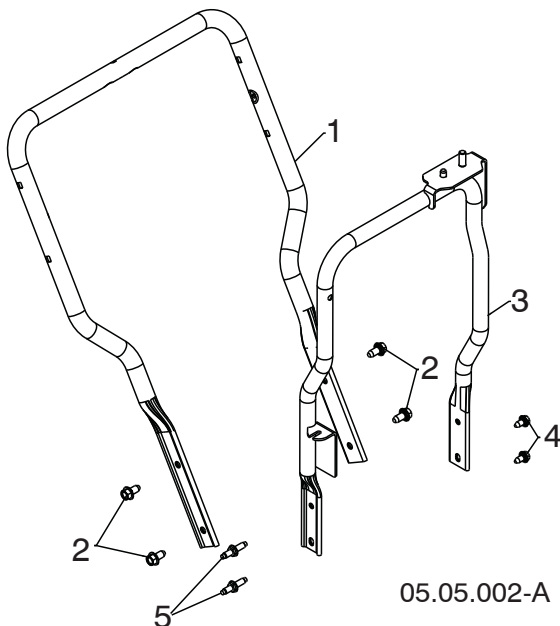

KEY NO.	PART NO.	DESCRIPTION
1	588 67 21-03	LOWER HANDLE
2	817 00 06-12	SCREW HEX WASH HD 3/8-16 X .75
3	589 26 45-02	CHUTE ROTATOR SUPPORT ASM
4	817 00 05-10	BOLT HEX 5/16-18
5	582 91 79-01	STUD - BOLTED HEX HEAD

NOTE: All component dimensions given in U.S. inches. 1 inch = 25.4 mm
IMPORTANT: Use only Original Equipment Manufacturer (O.E.M.) replacement parts.
 Failure to do so could be hazardous, damage your snow thrower and void your warranty.

REPAIR PARTS

DRIVE

SNOW THROWER - MODEL NO. **ST 330** (96193012800), PRODUCT NO. 961 93 01-28

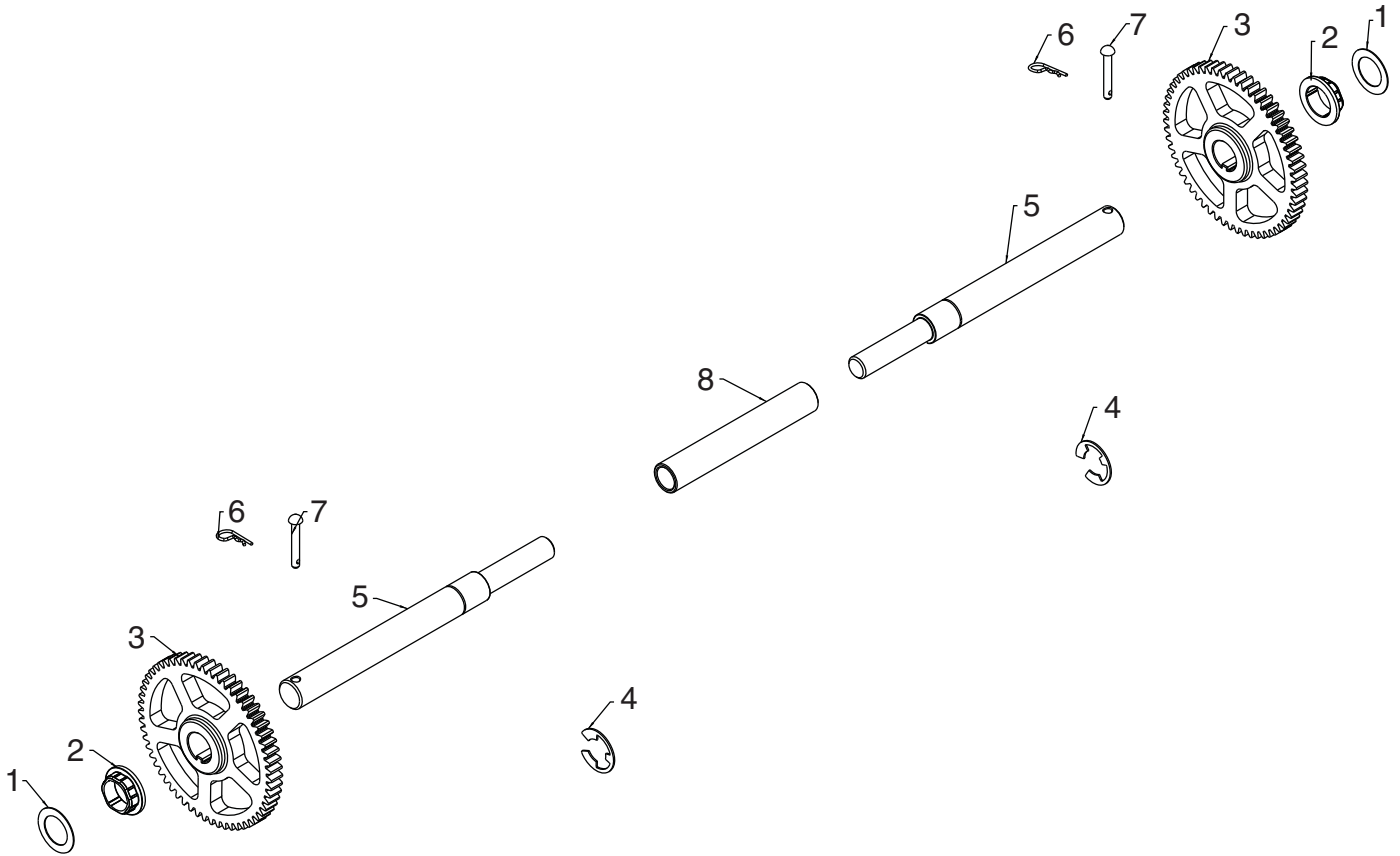

05.03.002-B

KEY NO.	PART NO.	DESCRIPTION
1	532 44 49-49	WASHER 1.00
2	587 97 89-01	BUSHING HEX 1 SHAFT
3	588 51 86-01	GEAR 59T DRIVEN
4	812 00 00-53	RETAINING RING
5	580 75 26-01	AXLE SHAFT SPLIT
6	532 12 47-88	RETAINER SPRING 1 ZINC
7	532 17 12-71	RIVET RD HD DRILLED 1/4 DIA
8	580 75 25-01	AXLE SLEEVE

NOTE: All component dimensions given in U.S. inches. 1 inch = 25.4 mm
IMPORTANT: Use only Original Equipment Manufacturer (O.E.M.) replacement parts.
 Failure to do so could be hazardous, damage your snow thrower and void your warranty.

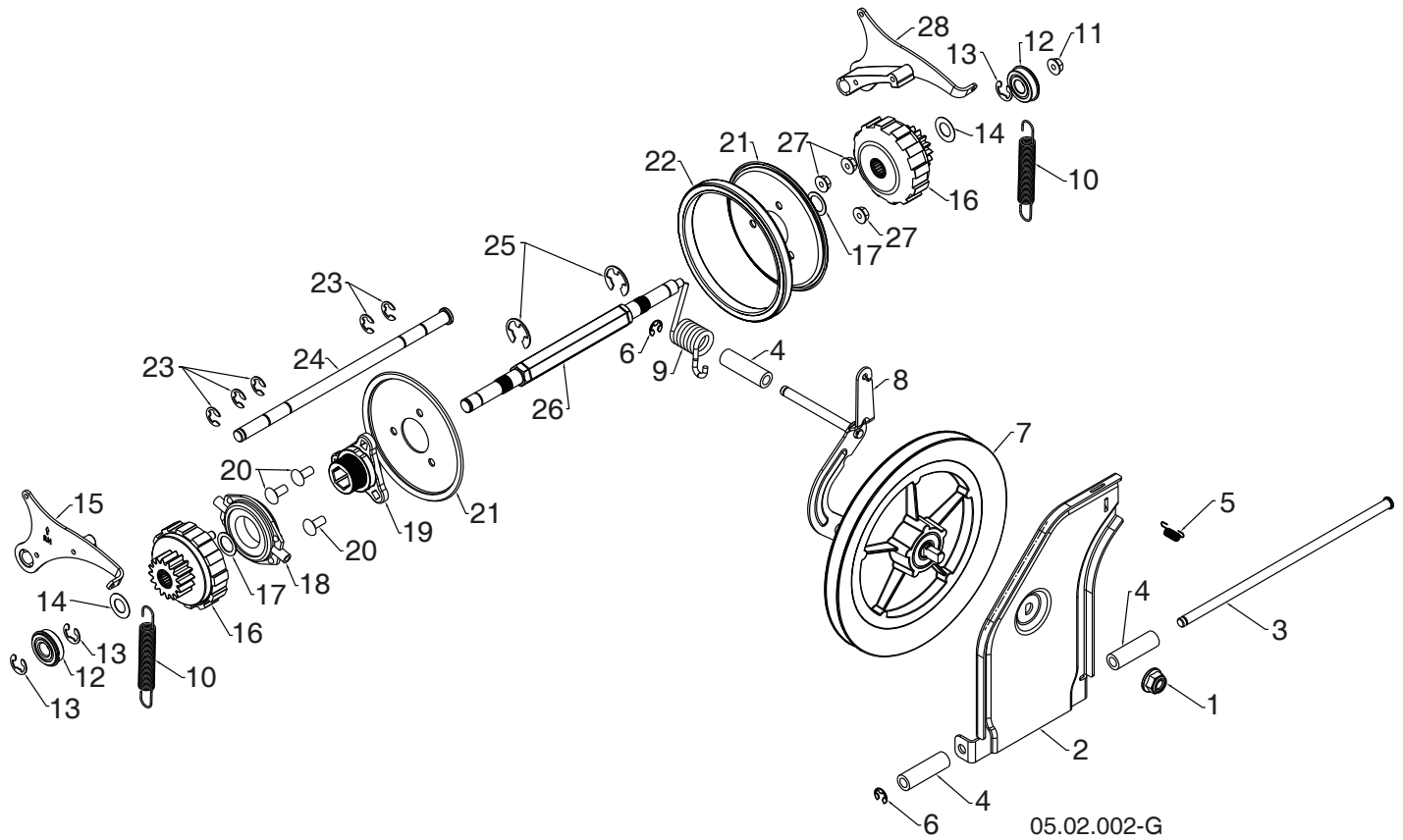

NOTE: All component dimensions given in U.S. inches. 1 inch = 25.4 mm
IMPORTANT: Use only Original Equipment Manufacturer (O.E.M.) replacement parts.
 Failure to do so could be hazardous, damage your snow thrower and void your warranty.

REPAIR PARTS**DRIVE****SNOW THROWER - MODEL NO. ST 330 (96193012800), PRODUCT NO. 961 93 01-28**

KEY NO.	PART NO.	DESCRIPTION
1	521 99 11-01	NUT HEX FLANGE LK 1/2-13
2	587 70 34-02	SWING PLATE FRICTION PULL
3	581 12 30-01	ROD TIP PLATE
4	581 73 27-01	SPACER DRIVE
5	532 19 38-85	LATCH SPRING
6	812 00 00-07	E-RING RETAINER
7	581 32 84-01	FRICTION DISC COMBO PULLEY
8	587 19 34-03	BRACKET YOKE ASSEMBLY
9	581 31 53-01	SPRING TORSION DRIVE
10	585 26 38-01	EXTENSION SPRING
11	585 69 15-01	NUT HEX FLANGE LOCK 5/16-18
12	580 75 62-01	BEARING 9/16 I.D. 1622-2RSNR
13	580 75 61-02	RETAINING RING 1622-2RSNR
14	580 75 13-01	WASHER FLAT .59 I.D. X 1.065 X 25 GA
15	580 75 66-01	PAWL ASM RH
16	580 75 60-01	GEAR ASM PLANETARY
17	580 75 63-01	WASHER FLAT .6875 I.D. X 1.00 X 21 GA
18	532 17 53-44	TRUNNION BEARING ASM
19	581 09 09-01	HUB RUBBER WHEEL
20	872 11 05-06	BOLT CARRIAGE 5/16-18 X .75
21	581 09 10-02	PLATE RUBBER WHEEL
22	581 09 11-01	RING RUBBER WHEEL
23	586 64 43-01	E-RING
24	580 75 51-01	ROD PAWL
25	812 00 00-22	E-RING
26	580 75 24-01	SHAFT REDUCTION PWR STR
27	532 75 11-53	NUT HEX FLANGE LK 5/16-18
28	580 75 67-01	PAWL ASM LH

NOTE: All component dimensions given in U.S. inches. 1 inch = 25.4 mm
IMPORTANT: Use only Original Equipment Manufacturer (O.E.M.) replacement parts.
Failure to do so could be hazardous, damage your snow thrower and void your warranty.

REPAIR PARTS

CHASSIS / ENGINE / PULLEYS

SNOW THROWER - MODEL NO. ST 330 (96193012800), PRODUCT NO. 961 93 01-28

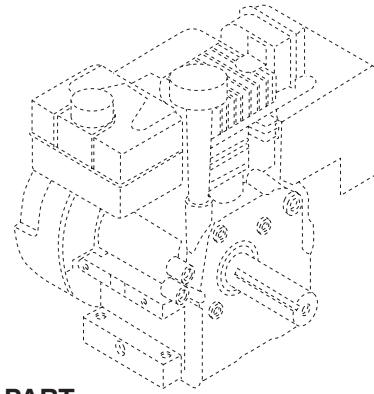
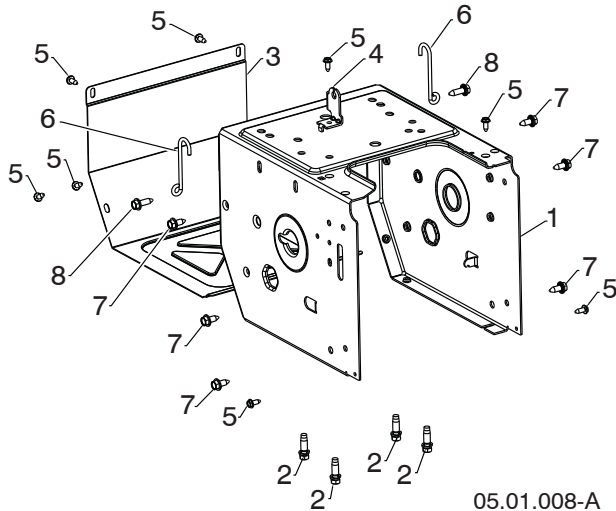

KEY NO.	PART NO.	DESCRIPTION
--	585 74 27-04	COMPLETE LCT ENGINE PW2HK181000178Y
1	589 26 47-05	FRAME
2	532 15 04-06	ENGINE BOLT 3/8-16 X 1.280 DOGPOINT
3	580 83 95-05	FRAME COVER
4	501 06 04-03	SHIFTER BRACKET
5	582 90 69-01	SCREW HEX WASHER 1/4-20 X 5/8
6	588 95 45-01	WIREFORM SUPPORT CABLE
7	532 42 88-67	BOLT HEXHD WASHER 5/16-18 X .75
8	585 21 75-01	BOLT HEXHD WASHER 5/16-18 X 1.00

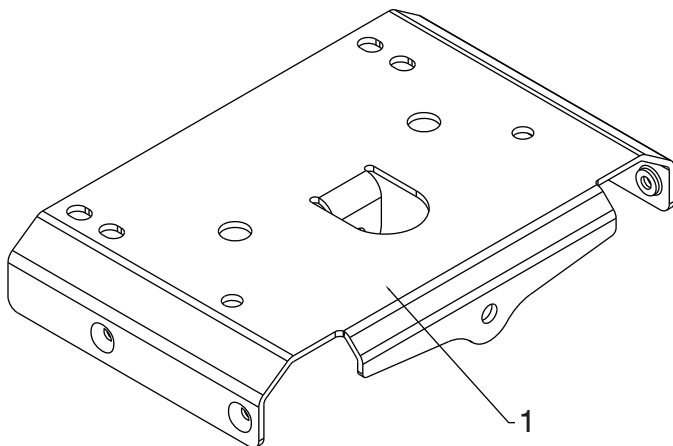

KEY NO.	PART NO.	DESCRIPTION
1	585 54 60-02	LARGE MOUNTING PLATE

NOTE: All component dimensions given in U.S. inches. 1 inch = 25.4 mm

IMPORTANT: Use only Original Equipment Manufacturer (O.E.M.) replacement parts. Failure to do so could be hazardous, damage your snow thrower and void your warranty.

REPAIR PARTS

CHASSIS / ENGINE / PULLEYS

SNOW THROWER - MODEL NO. ST 330 (96193012800), PRODUCT NO. 961 93 01-28

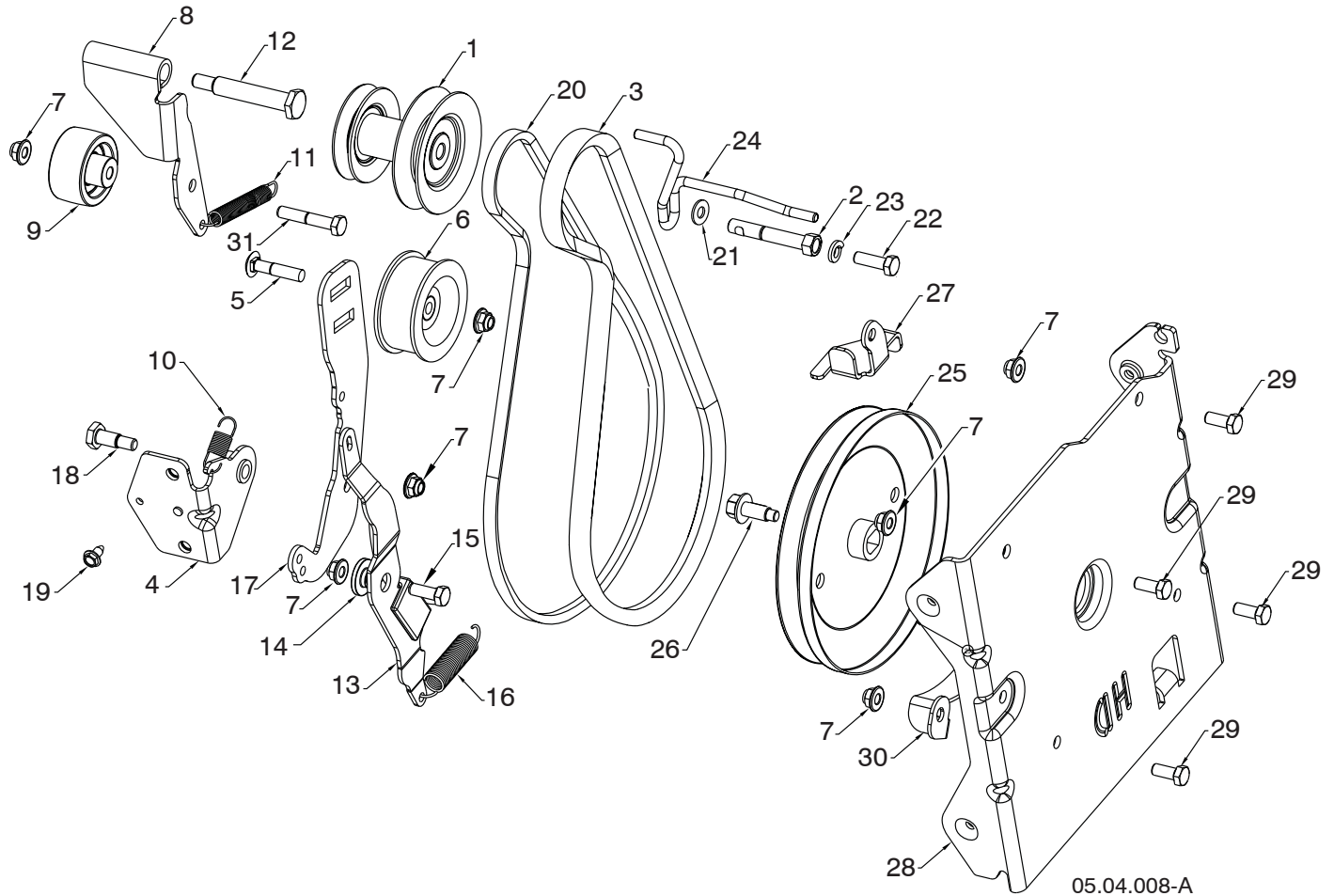

KEY NO.	PART NO.	DESCRIPTION	KEY NO.	PART NO.	DESCRIPTION
1	589 26 22-01	PULLEY ENGINE	18	589 26 36-01	SCREW HEX HEAD SHOULDER
2	582 38 84-01	BOLT	19	817 06 04-08	SCREW
3	589 26 26-02	BELT 5L	20	582 64 07-02	BELT 3L
4	589 26 34-02	BRACKET WELDMENT IDLER ARM	21	819 11 12-16	WASHER
5	589 28 45-01	BOLT CARRIAGE 5/16-18	22	874 61 05-12	SCREW
6	589 26 27-01	PULLEY IDLER	23	810 04 05-00	WASHER
7	532 42 79-42	NUT	24	589 26 24-01	GUIDE BELT 3L FRICTION 5L IMPELLER
8	593 19 25-02	ARM WELDMENT IDLER	25	589 26 38-01	PULLEY IMPELLER DD 5L HD
9	586 88 02-01	PULLEY IDLER FLANGELESS 2.0	26	583 81 49-01	SCREW FLANGE HEAD CAP WITH DOG POINT 3/8-16
10	589 26 37-01	SPRING IDLER RETURN	27	589 26 25-05	GUIDE BELT 5L
11	580 75 30-01	SPRING	28	501 59 54-02	INTERFACE BRACKET
12	581 41 38-01	BOLT	29	874 78 05-12	SCREW
13	579 76 33-01	ARM IMPELLER BRAKE HD	30	581 63 20-02	LOWER BELT KEEPER
14	587 34 37-01	BUSHING	31	874 76 05-28	SCREW 5/16-18 X 1.75
15	874 76 05-14	BOLT			
16	579 76 35-01	SPRING EXTENSION BRAKE			
17	589 26 29-02	ARM IDLER			

NOTE: All component dimensions given in U.S. inches. 1 inch = 25.4 mm
IMPORTANT: Use only Original Equipment Manufacturer (O.E.M.) replacement parts. Failure to do so could be hazardous, damage your snow thrower and void your warranty.

REPAIR PARTS

CHASSIS / ENGINE / PULLEYS

SNOW THROWER - MODEL NO. ST 330 (96193012800), PRODUCT NO. 961 93 01-28

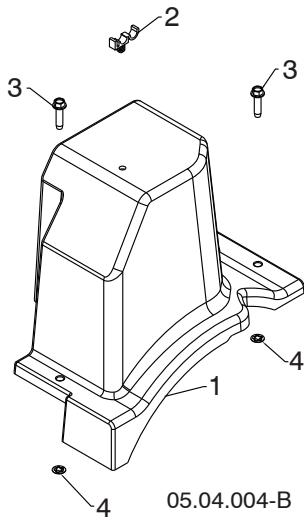

KEY NO.	PART NO.	DESCRIPTION
1	587 10 55-01	BELT COVER HI CRANK
2	532 14 50-06	CABLE GUIDE
3	-----	BOLT HEX WSH THDRL 1/4-20 X 1
4	-----	PALNUT 1/4 IN

NOTE: All component dimensions given in U.S. inches. 1 inch = 25.4 mm
IMPORTANT: Use only Original Equipment Manufacturer (O.E.M.) replacement parts.
Failure to do so could be hazardous, damage your snow thrower and void your warranty.

REPAIR PARTS

WHEELS

SNOW THROWER - MODEL NO. ST 330 (96193012800), PRODUCT NO. 961 93 01-28

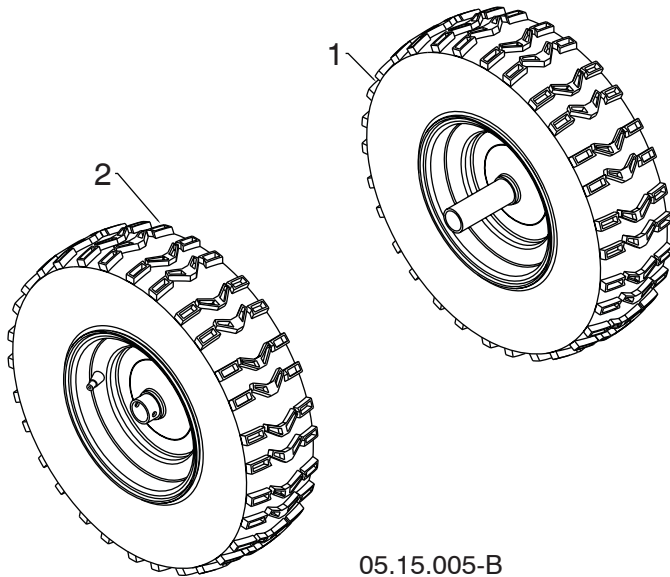

KEY NO.	PART NO.	DESCRIPTION
1	532 43 57-86	WHEEL 16X4.80 NPS LH 1.00 K478
2	532 43 57-88	WHEEL 16X4.80 NPS RH 1.00 K478

NOTE: All component dimensions given in U.S. inches. 1 inch = 25.4 mm
IMPORTANT: Use only Original Equipment Manufacturer (O.E.M.) replacement parts. Failure to do so could be hazardous, damage your snow thrower and void your warranty.

REPAIR PARTS

BAG OF PARTS

SNOW THROWER - MODEL NO. ST 330 (96193012800), PRODUCT NO. 961 93 01-28

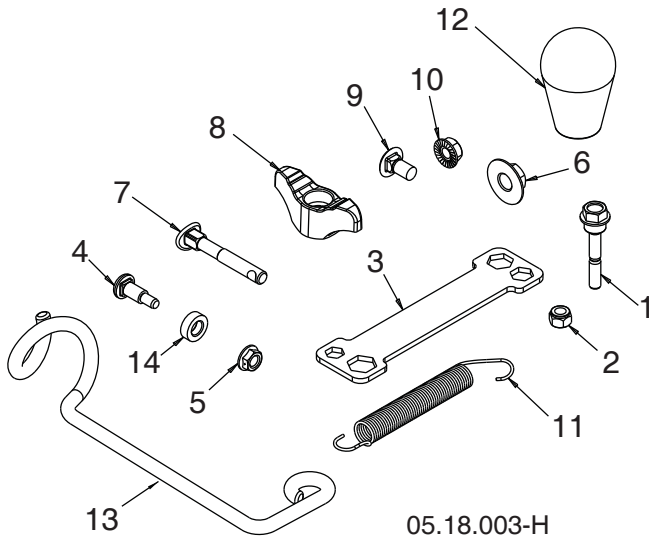

KEY NO.	PART NO.	DESCRIPTION
1	588 07 75-01	BOLT 1/4-20 X 1.81
2	873 80 04-00	NUT NYLOCK 1/4-20
3	532 42 91-12	WRENCH
4	501 41 73-01	BOLT SHOULDER
5	585 69 1401	NUT HEX FL 1/4-20 CTR
6	585 69 10-01	NUT NYLOCK 3/8-16
7	588 05 99-01	BOLT 5/16-18 X 2.25 CONCAVE
8	532 19 19-38	KNOB 5/16-18 TWO-WING
9	585 83 20-01	BOLT 5/16-18 X .625
10	873 97 05-00	NUT SERR FL LOCK 5/16-18
11	532 18 45-05	SPRING DEFLECT CHUTE
12	581 69 75-01	KNOB SOFT TOUCH SLOTTED
13	581 89 73-01	SUPPORT ROTATION CABLE
14	501 41 74-01	WASHER NYLON
NI	588 07 76-03	KIT REPLACEMENT BAG OF PARTS

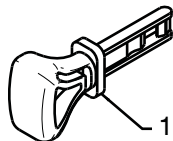

01.14.009-B

KEY NO.	PART NO.	DESCRIPTION
1	532 44 30-59	SAFETY IGNITION KEY KIT

NOTE: All component dimensions given in U.S. inches. 1 inch = 25.4 mm
IMPORTANT: Use only Original Equipment Manufacturer (O.E.M.) replacement parts. Failure to do so could be hazardous, damage your snow thrower and void your warranty.

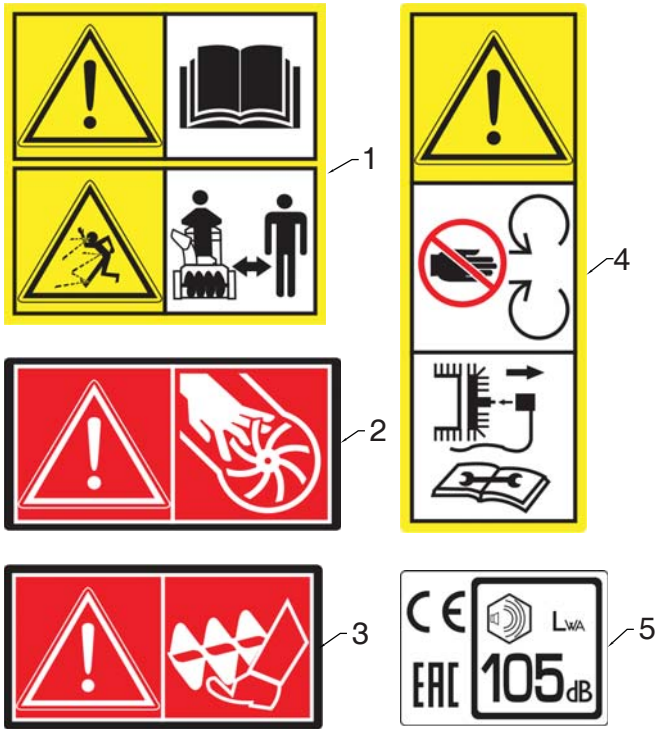

KEY NO.	PART NO.	DESCRIPTION
1	532 18 40-45	DECAL AUGER
2	590 81 22-01	DECAL CHUTE
3	532 19 96-83	DECAL AUGER SAFETY
4	532 18 40-28	DECAL BELT GUIDE
5	589 59 27-01	DECAL NOISE LEVEL

05.16.002-B

NOTE: All component dimensions given in U.S. inches. 1 inch = 25.4 mm
IMPORTANT: Use only Original Equipment Manufacturer (O.E.M.) replacement parts. Failure to do so could be hazardous, damage your snow thrower and void your warranty.

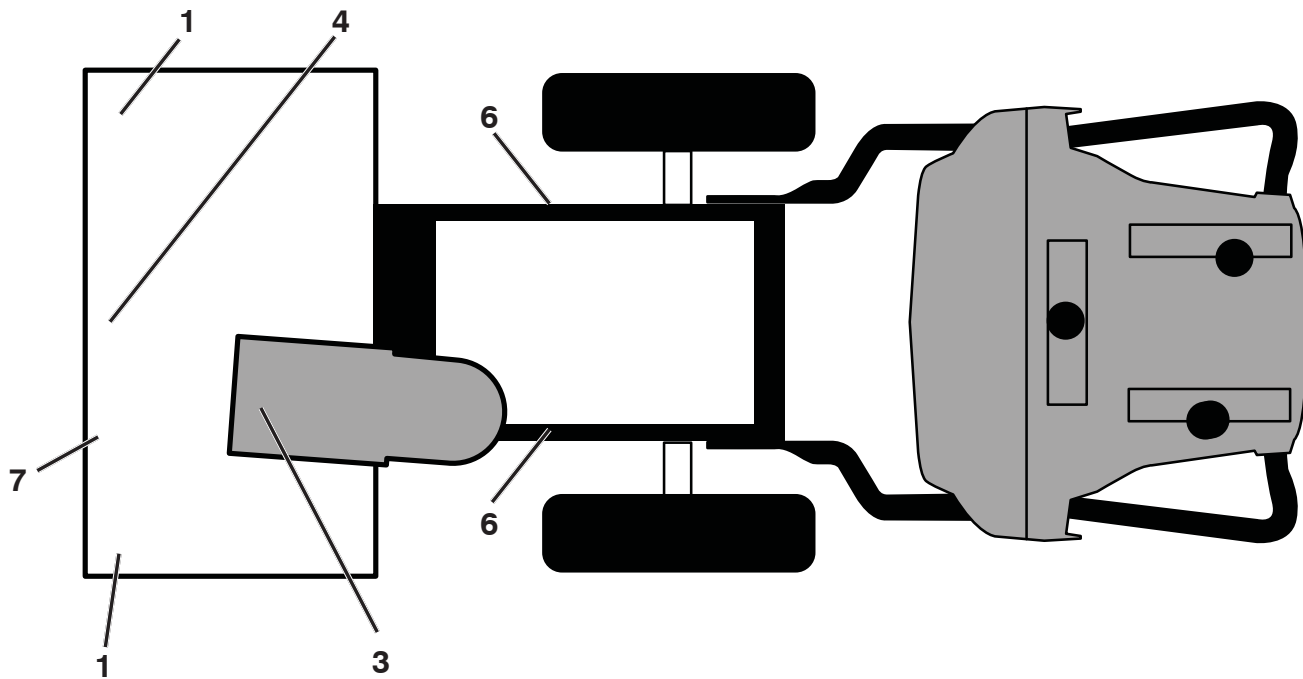

KEY PART NO.	PART NO.	DESCRIPTION
1	532 19 96-83	DECAL, AUGER
3	590 81 22-01	DECAL, DANGER, DEFLECTOR
4	532 18 40-45	DECAL, DANGER
6	532 18 40-28	DECAL, BELT GUARD
7	593 09 65-01	DECAL, AUGER HUSQ.
--	532 42 86-77	"H" EMBLEM (NOT SHOWN)
--	590 69 72-01	DECAL, ENGINE RECOIL (NOT SHOWN)
--	115 99 61-20	OPERATOR'S MANUAL, EURO
--	115 99 61-10	OPERATOR'S MANUAL, SCAN
--	115 99 61-50	OPERATOR'S MANUAL, EBLOC
--	115 99 61-40	OPERATOR'S MANUAL, BALTIC

NOTE: All component dimensions given in U.S. inches. 1 inch = 25.4 mm
IMPORTANT: Use only Original Equipment Manufacturer (O.E.M.) replacement parts. Failure to do so could be hazardous, damage your snow thrower and void your warranty.

ENGINE, LCT

COMPLETE ENGINE-585742704

GEN II 291/306/369/414/420cc Snow Engines

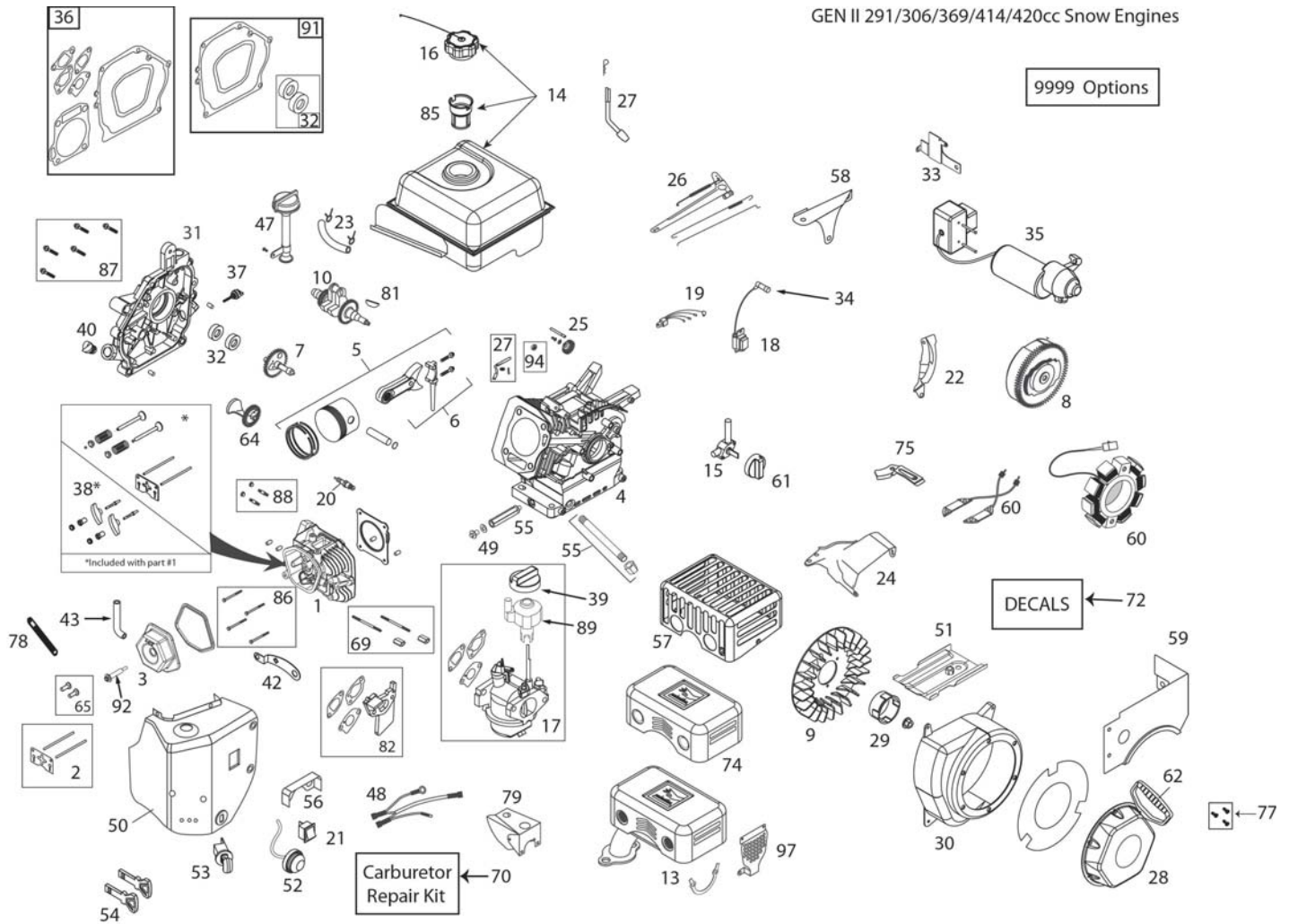

ILLUSTRATION FOR REFERENCE PURPOSES ONLY

KEY PART NO.	NO.	DESCRIPTION
1	587 17 68-01	CYLINDER HEAD 369CC
2	532 42 96-06	PUSH ROD & PLATE KIT (414CC) (INCL. VALVE COVER GSKT)
3	532 42 93-03	VALVE COVER (291/414CC) (INCL. GASKET)
4	N/A	N/A
5	582 50 52-01	PISTON AND ROD ASSEMBLY 369CC
6	N/A	N/A
7	532 42 93-13	CAMSHAFT - MCR (414CC)
8	532 44 39-00	FLYWHEEL - ELECTRIC START (5-CHARGING MAGNETS) (414CC)
9	532 42 93-06	COOLING FAN - FLYWHEEL (PLASTIC - 414CC)
10	587 15 13-01	CRANKSHAFT - #18 369/414CC
13	587 19 87-01	QUIET MUFFLER-HOP-369CC-SNOW
14	532 42 92-09	FUEL TANK (3.6L BLACK SNOW 414CC)
15	532 42 92-34	FUEL TANK ON/OFF VALVE (PETCOCK) - GEN II SNOW

KEY PART NO.	NO.	DESCRIPTION
16	532 42 92-11	FUEL TANK CAP - BLACK PLASTIC (VENTED) (SAME ASSKSN0301.1)
17	587 17 91-01	CARBURETOR WITH IDLE DOWN 369CC
18	532 44 39-44	CDI IGNITION COIL (291/414CC STANDAR WIRE - USED ON 1-PC IGN)
19	N/A	N/A
20	532 42 49-39	SPARK PLUG
21	532 42 92-23	ON/OFF SWITCH - ROCKER (SAME AS SKSN0403.1)
22	N/A	N/A
23	532 43 21-46	FUEL HOSE KIT (229MM)
24	591 09 77-01	SPEED CONTROL -FIXED
25	532 42 93-12	GOVERNOR GEAR ASSEMBLY
26	532 42 93-10	GOVERNOR ARM & LINK KIT (414CC)
27	532 42 93-11	GOVERNOR ARM PADDLE
28	582 62 15-01	RECOIL STARTER - BLACK 369/414CC SNOW (JPC)
29	582 62 16-01	STARTER CUP - 369/414CC SNOW (JPC)

ENGINE, LCT**COMPLETE ENGINE-585742704**

KEY NO.	PART NO.	DESCRIPTION	KEY NO.	PART NO.	DESCRIPTION
30	587 39 41-01	BLOWER HOUSING MATTE BLACK 369/414CC (W/FRT OIL DRAIN)	60	532 44 38-96	CHARGING COIL (60-WATT AC) (291/414CC)
31	580 98 41-01	CYLINDER COVER (HOFT FEARURES)(FULL-FACE GASKET SURFACE)	61	532 43 27-52	FUEL CONTROL KNOB (GEN II SNOW - RED)
32	532 42 93-16	OIL SEAL KIT (414CC)	62	532 44 38-99	STARTER GRIP-SNOW (DELUXE)
33	532 42 92-90	ELECTRIC STARTER SWITCH BOX BRACKET - 291/414CC SNOW	64	532 42 96-08	COUNTER WEIGHT KIT
34	532 43 69-66	SPARK PLUG BOOT - WITH METAL SHIELD (SNOW)	65	581 37 29-01	TAPPET KIT (291/414CC)(SET OF 2)
35	532 43 74-65	230V ELECTRIC STARTER (414CC)	69	586 32 67-01	CARBURETOR MTG STUD KIT (2)
36	587 17 94-01	ENGINE GASKET KIT 369CC	70	580 35 37-01	CARBURETOR REPAIR KIT (291/414CC)
37	532 43 55-34	SMALL BLACK OIL DIPSTICK (PLASTIC)	72	587 15 22-01	TWO STAGE SNOW DECAL KIT
38	532 42 96-12	ROCKER ARM KIT (291/414CC) (INCL. GASKET)	74	587 37 53-01	MUFFLER HEAT SHIELD (369/414CC)
39	532 42 92-24	CHOKE CONTROL KNOB (GEN II RED)	75	532 42 92-32	SHIELD-FLYWHEEL(414CCSNOW)
40	532 42 92-42	NON-REMOVABLE PLASTIC PLUG (291/414CC)	76	N/A	N/A
42	N/A	N/A	77	532 43 26-88	RECOIL BOLT KIT (3 BOLTS PER KIT)
43	587 17 96-01	BREATHER TUBE (W/PROTECTIVE SLEEVE)	78	585 77 13-01	BREATHER TUBE RETAINING STRAP
47	532 42 92-37	HIGH OIL-FILL TUBE & CAP (NO DIPSTICK)	79	587 15 20-01	SHIELD - CARBURETOR COVER - 291/414CC
48	532 42 92-62	WIRE HARNESS (208CC SNOW)	81	585 29 72-01	WOODRUFF FLYWHEEL KEYS (5-PACK) (5X6X18MM) (208/414CC)
49	532 43 54-94	OIL DRAIN PLUG W/WASHER (291/414CC)	82	585 02 05-01	414CC CARBURETOR SPACER KIT
50	532 42 92-94	CARBURETOR HEATER BOX MATTE BLACK - GEN II 369/414CC	85	586 32 56-01	FUEL TANK STRAINER
51	532 42 92-31	SHIELD - CYLLNDER	86	586 32 74-01	CYLINDER HEAD BOLT KIT (4) (291-414CC)
52	532 42 92-18	PRIMER BULB WITH HOSE-SNOW (SAME AS SKSN0304.1)	87	586 32 70-01	CC COVER BOLT KIT (7) (414CC)
53	532 42 92-21	SAFETY KEY SWITCH W/KEYS (SAME AS SKSN0401.1)	88	586 32 68-01	MUFFLER MTG STUD KIT (2)
54	532 44 30-59	KEY SET - RED (2) (SNOW)	89	587 12 48-01	SPEED CONTROL KNOB (GREY)
55	587 13 99-01	OIL DRAIN TUBE (96.5MM) WITH CAP NUT	91	587 99 41-04	CRANKSHAFT GASKET KIT 369-414CC
56	532 42 92-13	CARBURETOR VAPOR SHIELD - 414CC SNOW	92	587 99 52-01	VALVE COVER BOLT WITH SEAL
57	532 43 74-66	CE MUFFLER GUARD	94	588 48 55-01	GOV SHAFT OIL SEAL
58	532 42 92-98	SHIELD - GOVERNOR LINKAGE	97	590 04 66-01	MUFFLER MANIFOLD SHIELD
59	582 62 17-01	FUEL TANK SKIRT (369/414CC SNOW) FOR JPC RECOIL	9999	586 32 65-01	HIGH ALTITUDE JET (>6,000 FEET) 369CC L16 AND 414CC L12
			9999	579 80 64-01	BOLT KIT - BLWR HGS/HEATER BOX/TANK SKIRT

