

Repair Parts Manual
Manuel De Pièces De Rechange
GTH27V48LS / 96043011702

Please read the operator's manual carefully and make sure
you understand the instructions before using the machine.

Lisez très attentivement et soyez certain de comprendre
ces instructions avant d'utiliser cette machine.



English/French



HOW TO USE THIS MANUAL

This manual is designed to provide the customer with a means to identify the parts on his/her tractor when ordering repair parts. The illustrations may or may not represent the actual assemblies; therefore, it is not recommended to use this manual as a guide to assemble or disassemble the tractor. Some hardware and parts are drawn larger in order to more readily identify them.

Each tractor has its own model number.

The model number for your tractor can be found on the fender under the seat.

When ordering parts, always give the following information:

- Product - "TRACTOR"
- MODEL NUMBER - "GTH27V48LS" (96043011702)"
- Part Number
- Part Description

TABLE OF CONTENTS

SCHEMATIC	3
ELECTRICAL.....	4-5
CHASSIS	6-7
DRIVE.....	8-9
ENGINE.....	10-11
STEERING	12-13
MOWER DECK.....	14-15
MOWER LIFT.....	16
SEAT	17
DECALS.....	18

COMO UTILIZAR ESTE MANUAL

Este manual está diseñado para brindarle al comprador un medio para identificar las piezas del tractor para cuando necesite hacer el pedido de un repuesto. Las ilustraciones pueden o no representar los ensambles reales; por lo tanto, no se recomienda utilizar este manual como una guía para ensamblar o desarmar el tractor. Algunos accesorios y piezas están dibujados en tamaños más grandes para identificarlos con mayor facilidad.

Cada tractor tiene su propio número de modelo.

El número de modelo del tractor se encuentra en el guardabarros debajo del asiento.

Cuando haga el pedido de una pieza, siempre brinde la siguiente información:

- Producto: "TRACTOR"
- NÚMERO DE MODELO: "GTH27V48LS" (96043011702)"
- Número de pieza
- Descripción de la pieza

ÍNDICE

DIAGRAMA.....	19
DIAGRAMA ELÉCTRICO	20-21
CHASIS.....	22-23
TRANSMISIÓN	24-25
MOTOR	26-27
DIRECCIÓN	28-29
PLATAFORMA DE LA CORTADORA DE CÉSPED.....	30-31
ELEVACIÓN DE LA CORTADORA DE CÉSPED.....	32
ASIENTO.....	33
CALCOMANÍAS.....	34

TRACTOR - MODEL NO. GTH27V48LS (96043011702), PRODUCT NO. 960 43 01-17 SCHEMATIC

SCH12

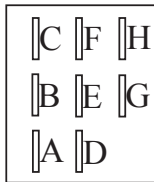
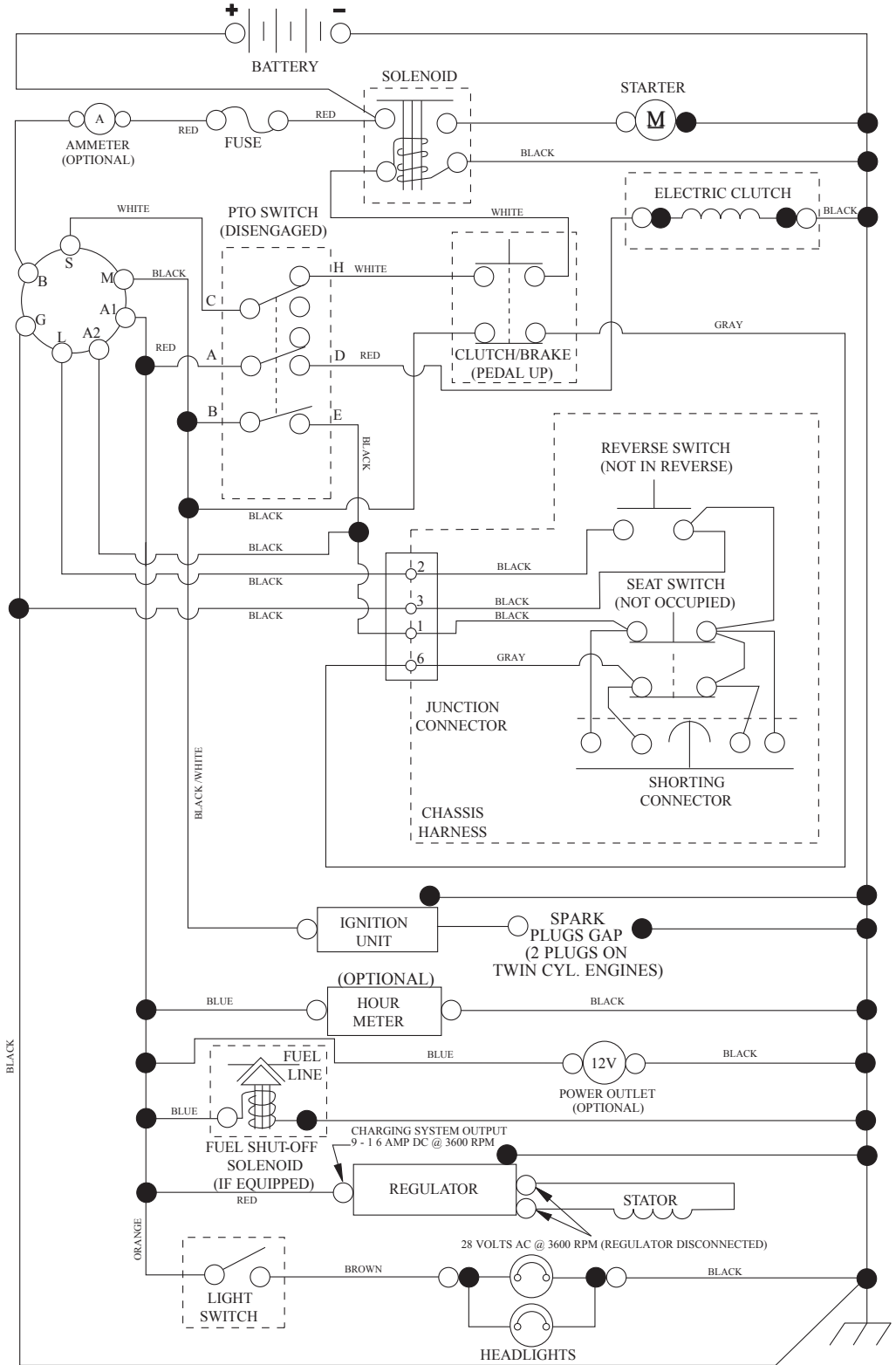

PTO SWITCH
(MATING SIDE)

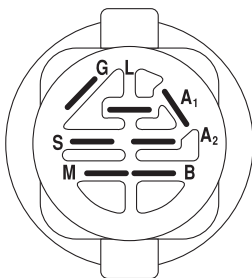

IGNITION SWITCH

POSITION	CIRCUIT	"MAKE"
OFF	M+G+A1	
RUN/OVERRIDE	B+A1	
RUN	B+A1	L+A2
START	B + S + A1	

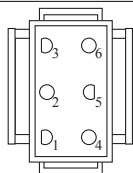

CHASSIS HARNESS
CONNECTOR
(MATING SIDE)

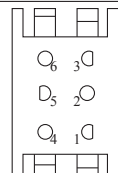

DASH HARNESS
CONNECTOR

WIRING INSULATED CLIPS
NOTE: IF WIRING INSULATED
CLIPS WERE REMOVED FOR
SERVICING OF UNIT, THEY
SHOULD BE RE-INSTALLED TO
PROPERLY SECURE YOUR
WIRING.

●
NON-REMOVABLE
CONNECTIONS

○
REMOVABLE
CONNECTIONS

**TRACTOR - MODEL NO. GTH27V48LS (96043011702), PRODUCT NO. 960 43 01-17
ELECTRICAL**

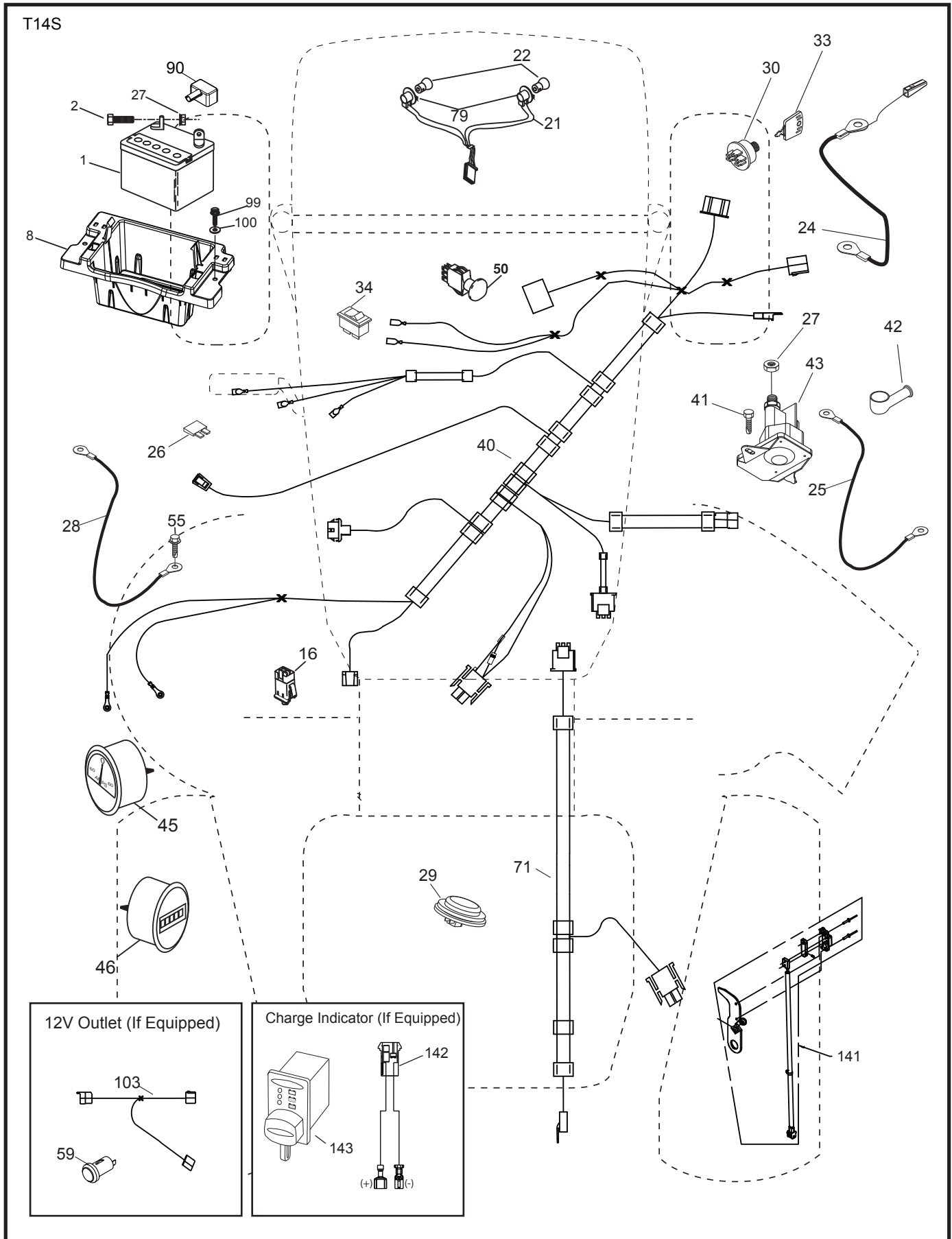

**TRACTOR - MODEL NO. GTH27V48LS (96043011702), PRODUCT NO. 960 43 01-17
ELECTRICAL**

KEY NO.	PART NO.	DESCRIPTION
1	532 16 34-65	Battery
2	874 76 04-12	Bolt Hex Hd 1/4-20 unc x 3/4
8	532 18 64-91	Battery Box
16	532 17 61-38	Switch Interlock
21	532 40 02-52	Harness Socket Light
22	532 00 41-52	Bulb, Light #1156
24	532 40 02-53	Cable Battery
25	532 41 28-95	Cable Starter
26	532 17 51-58	Fuse
27	873 51 04-00	Nut Keps Hex 1/4-20 unc
28	532 14 54-91	Cable Ground 21" Blk 6 Ga.
29	532 40 15-45	Switch Seat
30	532 19 33-50	Switch Ign
33	532 41 19-33	Key/Chain
34	532 11 07-12	Switch Light/Reset
40	532 42 90-83	Harness Ign. Dash
41	817 72 04-08	Screw 1/4-20 unc x 1/2
42	532 13 15-63	Cover Terminal Red
43	532 19 25-07	Solenoid
45	532 42 52-70	Ammeter Round
46	532 42 52-71	Gauge Hourmeter
50	532 17 46-51	Switch PTO
55	817 06 05-12	Screw Thdrol 5/16-18 x 3/4
59	532 40 03-03	Outlet 12-Volt
71	532 19 42-76	Harness Ign
79	532 17 52-42	Socket Asm. Bulb Twistlock
90	532 43 53-95	Cover Terminal Battery
91	532 19 02-70	Strap Battery
99	817 67 04-12	Screw Hexwsh Thdrol 1/4-20 x 3/4
100	819 09 14-16	Washer 9/32 x 7/8 x 16 Ga.
103	532 42 17-47	Harness Pigtail 12V Outlet
141	532 42 12-25	Kit G700/G730 ROS

NOTE: All component dimensions given in U.S. inches
1 inch = 25.4 mm

TRACTOR - MODEL NO. GTH27V48LS (96043011702), PRODUCT NO. 960 43 01-17
CHASSIS

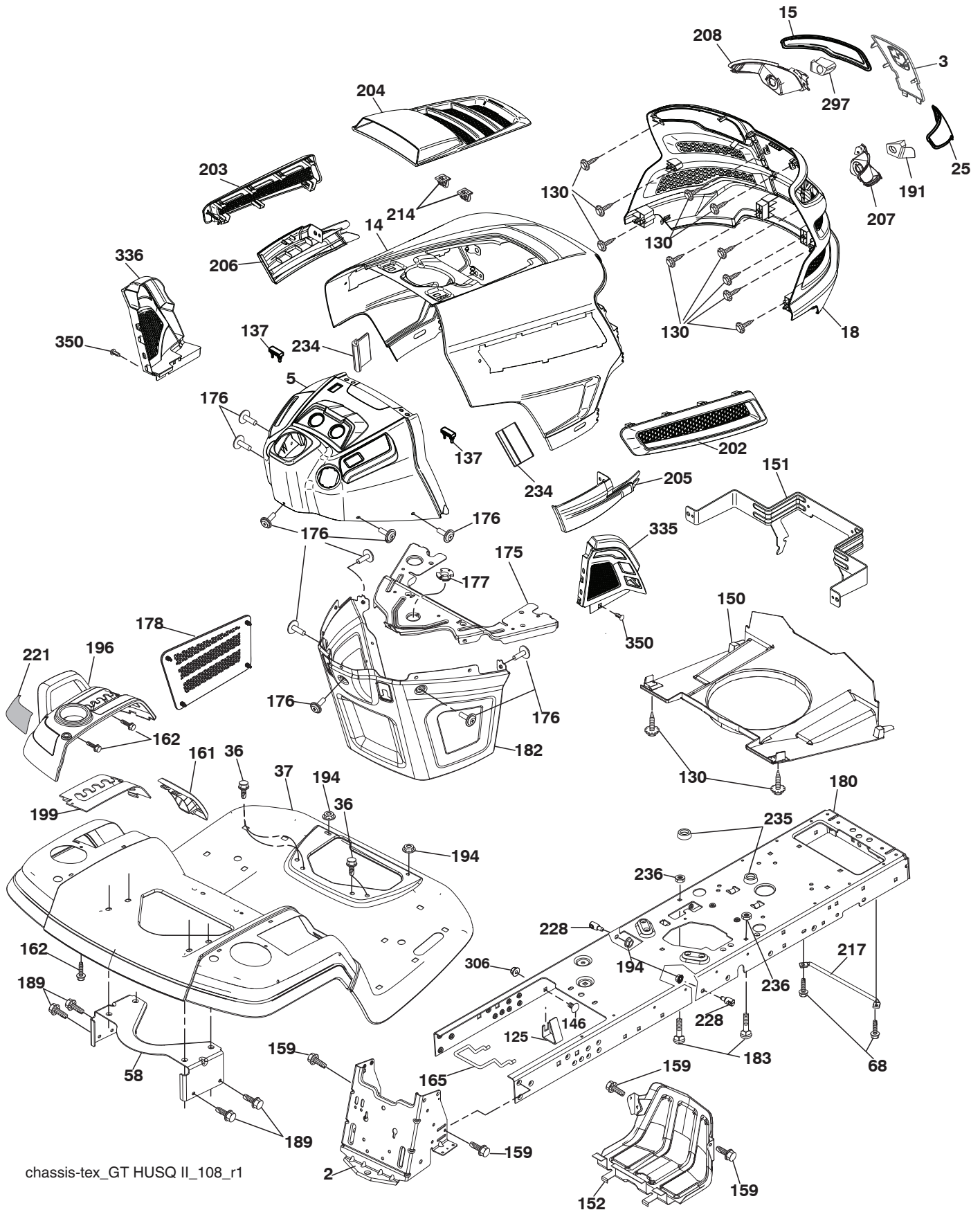

chassis-tex_GT HUSQ II_108_r1

**TRACTOR - MODEL NO. GTH27V48LS (96043011702), PRODUCT NO. 960 43 01-17
CHASSIS**

KEY NO.	PART NO.	DESCRIPTION
2	580 43 44-01	Drawbar
3	532 43 97-52	Applique
5	532 43 74-77	Dash
14	532 44 11-77	Hood
15	532 43 97-33	Lens LH
18	532 44 06-53	Grille Asm
25	532 44 33-85	Lens RH
36	817 06 05-12	Screw 5/16-18 x 3/4
37	532 44 12-08	Fender
58	532 19 43-14	Bracket Fender
68	817 49 05-08	Screw 5/16-18 x 1/2
125	581 68 48-01	Clip Fuel Line
130	532 41 63-58	Screw #10 x 0.750 BOS Thread
137	532 40 75-90	Bumper Dash
146	581 85 79-01	Bolt
150	532 43 97-74	Duct Heat Hood
151	532 43 66-70	Pivot Bracket
152	532 43 98-70	Shield Browning/Debris
159	817 00 06-12	Screw 3/8-16 x 3/4
161	532 43 99-29	Console Fuel Window
162	532 14 24-32	Screw Hex Wsh Hi-Lo 1/4 x 1/2
165	532 19 43-30	Bracket Support Tank
175	532 19 63-04	Crossmember
176	532 40 07-76	Screw 10-24 x 5/8 Wshd Qdrx
177	532 19 52-27	Bushing Steering
178	532 19 97-82	Cargo Asm. Net
180	532 44 55-59	Chassis
182	532 40 68-59	Dash Lower
183	874 52 05-20	Bolt 5/16-18 x 1-1/4
189	817 00 05-12	Screw 5/16-18 x 3/4

KEY NO.	PART NO.	DESCRIPTION
191	532 43 74-55	Insert Reflective RH
194	873 90 05-00	Nut Lock Hex Flange 5/16-18
196	532 43 96-74	Console Asm. Deck Lift
199	532 19 82-59	Plate Deck Lift
202	532 43 97-28	Vent Side Hood RH
203	532 43 97-27	Vent Side Hood LH
204	532 43 57-14	Vent Asm Hood Top
205	532 43 97-30	Hood Bumper Extension RH
206	532 43 97-29	Hood Bumper Extension LH
207	532 43 97-34	Bezel RH
208	532 43 97-35	Bezel LH
214	532 19 91-45	Clip Retainer
217	532 40 91-67	Rod Pivot
221	532 19 89-09	Reflector LH
228	532 19 51-61	Stud Fastener
234	532 40 47-42	Bumper Hood
235	532 40 61-29	Spacer Fender
236	873 93 05-00	Nut Center Lock 5/16-18 unc
297	532 43 74-56	Insert Reflective LH
306	873 90 06-00	Nut Lock
335	532 44 82-04	Cover RH Lower Close Out
336	532 44 53-09	Cover Lower Dash LH
350	532 44 51-43	Clip X-mas Tree
--	532 42 49-18	Kit Gaurd Brush

NOTE: All component dimensions given in U.S. inches
1 inch = 25.4 mm

**TRACTOR - MODEL NO. GTH27V48LS (96043011702), PRODUCT NO. 960 43 01-17
DRIVE**

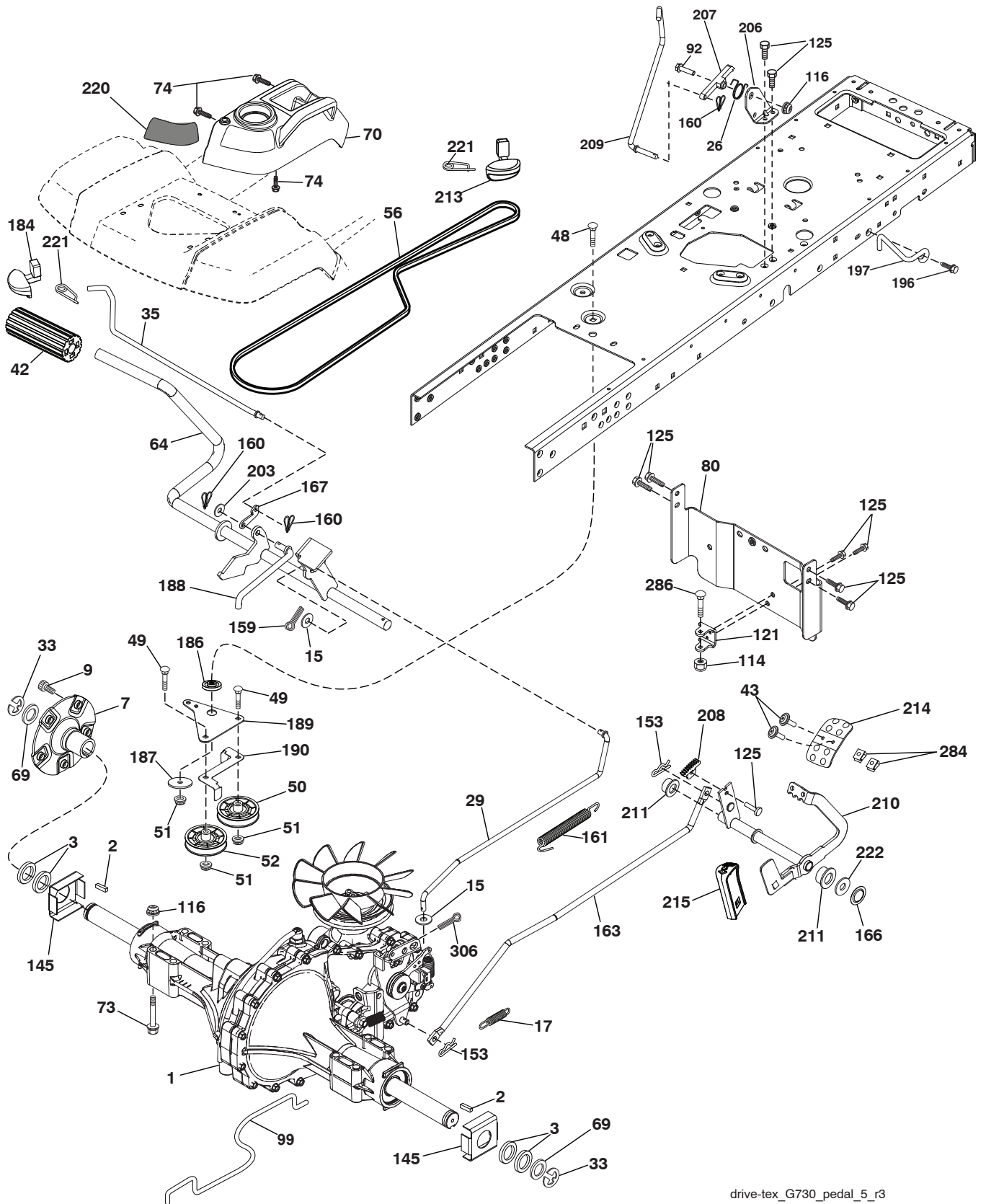

drive-tex_G730_pedal_5_r3

TRACTOR - MODEL NO. GTH27V48LS (96043011702), PRODUCT NO. 960 43 01-17 DRIVE

KEY NO.	PART NO.	DESCRIPTION	KEY NO.	PART NO.	DESCRIPTION
1	---	Transaxle, Hydro G7-BCBB-1XDC-1FCA (420331) (Order parts from transaxle manufacturer.)	153	532 12 47-88	Retainer Spring
2	532 00 70-70	Key 1/4 x 2.5	159	876 02 04-12	Pin Cotter 1/8 x 3/4
3	532 00 75-63	Washer Thrust Axle Hardened	160	532 16 94-84	Retainer Clip
7	532 19 98-37	Hub Asm. Wheel	161	532 10 57-09	Spring, Return, Clutch
9	532 14 00-80	Bolt Hub Wheel	163	532 41 81-85	Rod Pedal Control
15	819 13 13-16	Washer 13/32 x 13/16 x 16 Ga.	166	532 42 91-64	Nut Push .625
17	532 19 72-96	Spring, Brake	167	532 40 52-57	Latch Brake Parking
26	532 19 96-79	Spring Return Cruise	184	532 44 14-55	Handle Parking Brake
29	532 41 81-86	Rod, Brake	186	532 19 43-21	Spacer Retainer
33	812 00 00-53	Ring E	187	819 13 32-10	Washer
35	583 86 45-01	Rod, Brake, Park	188	532 19 43-23	Link Clutch Ground Drive
42	532 12 48-72	Cover, Foot Pedal	189	532 40 75-04	Bellcrank Ground Drive
43	874 18 04-12	Screw 1/4-20 x 3/4	190	532 40 75-05	Keeper Bellcrank Ground Drive
48	872 11 06-12	Bolt Carr Sh 3/8-16 x 1-1/2 Gr.5	196	817 00 06-16	Screw 3/8-16 x 1
49	872 11 06-14	Bolt	197	532 19 97-69	Bracket Clutch Anti-Rotation
50	532 19 43-27	Pulley Idler Flat	203	819 11 11-16	Washer 11/32 x 11/16 x 16 Ga.
51	873 90 06-00	Lock Nut 3/8-16	206	532 19 78-67	Bracket Mount Latch Cruise
52	532 19 43-26	Idler V-Groove	207	532 19 78-68	Latch Control Cruise
56	532 42 08-07	V-Belt, Drive	208	532 19 78-69	Gear Sector Control Cruise
64	532 19 78-65	Shaft Asm. Pedal Brake Control	209	532 19 95-92	Rod Control Cruise
69	532 12 38-00	Washer 1-1/32 x 1-5/8 x 16 Ga.	210	532 19 78-60	Rocker Asm. Pedal Control
70	532 43 96-61	Console Asm	211	532 12 01-83	Bearing Nylon
73	874 49 05-48	Bolt Hex 5/16-18 x 3 Gr. 5	213	532 40 31-19	Knob Control Cruise
74	532 14 24-32	Screw 1/4 x 1/2	214	532 41 68-63	Pedal Forward
80	532 41 81-84	Strap Torque	215	532 40 17-23	Pedal Reverse
92	874 76 05-20	Bolt 5/16-18 x 1/2	220	532 19 89-08	Reflector RH
99	532 41 81-88	Spring Bypass	221	532 40 31-87	Retainer Spring Clip Handle
114	873 80 05-00	Nut Lock Hex W/Ins. 5/16-18 unc	222	879 21 20-10	Washer 21/32 x 1-1/4 x 10 Ga.
116	873 90 05-00	Nut Lock Hex Flange 5/16-18	284	532 41 76-93	Nut U-Channel 1/4-20
121	532 17 56-11	Bracket Strap Torque	286	872 01 05-20	Bolt 5/16-18 x 2.50
125	817 00 05-12	Screw 5/16-18 x 3/4	306	876 02 04-16	Pin Cotter 1/8 x 1
145	532 16 31-68	Washer Axle Flange			

NOTE: All component dimensions given in U.S. inches
1 inch = 25.4 mm

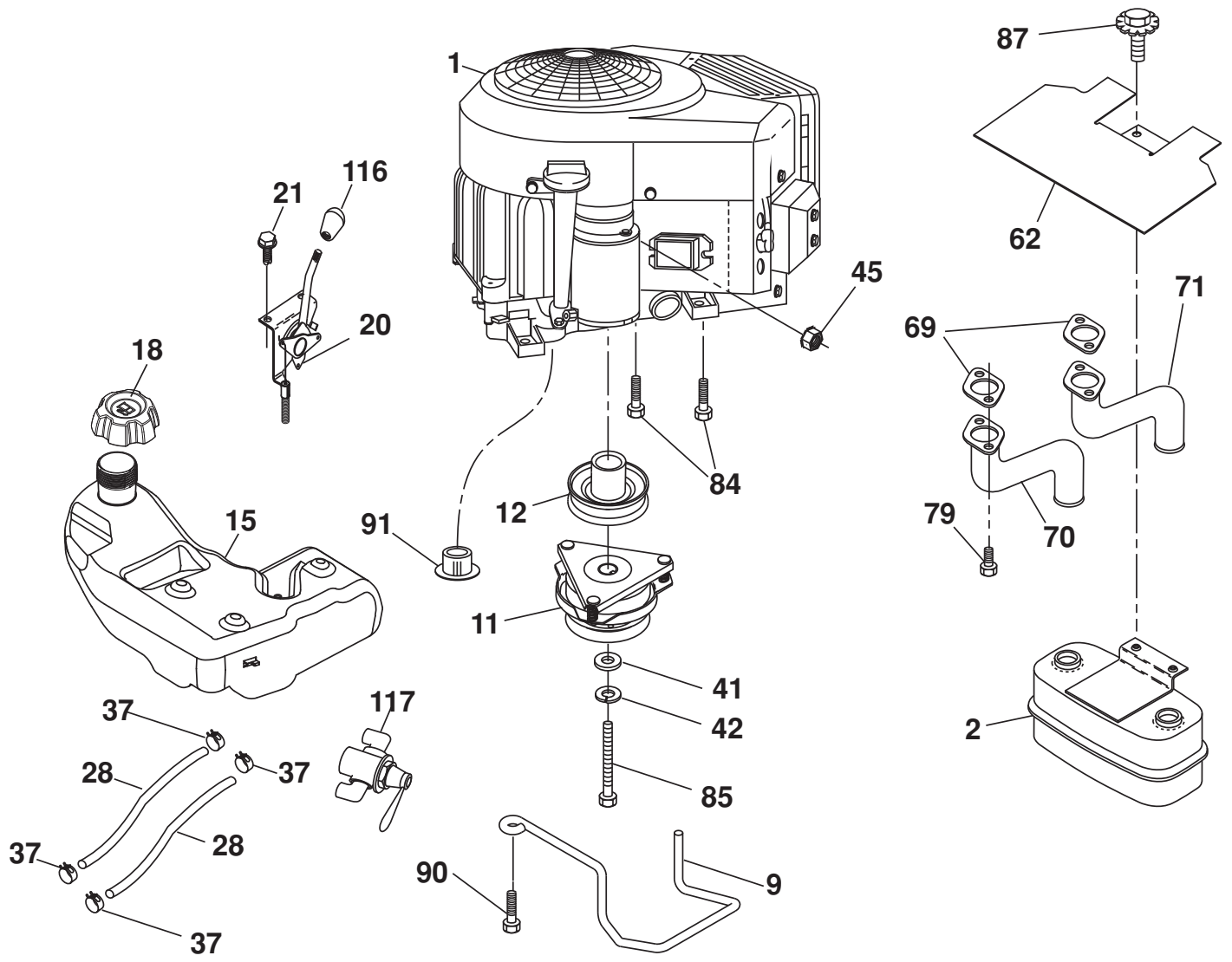

SPARK ARRESTER KIT

engine-tex_bs-2cyl_26

TRACTOR - MODEL NO. GTH27V48LS (96043011702), PRODUCT NO. 960 43 01-17 ENGINE

KEY NO.	PART NO.	DESCRIPTION
1	— — — — —	Engine B&S Model No. 44Q777-2406-G5(438243) (Order parts from engine manufacturer.)
2	532 44 59-62	Muffler
9	532 40 86-67	Keeper Asm. Belt Engine
11	532 17 93-35	Clutch Electric
12	532 19 43-43	Pulley Engine
15	532 43 80-82	Tank Fuel 4R
18	532 43 92 08	Cap Asm
20	532 42 43-41	Control Throttle
21	532 41 63-58	Screw #10 x 0.750 BOS Thread
28	532 40 11-35	Fuel Line
29	532 13 71-80	Spark Arrester Kit
37	532 12 34-87	Clamp Hose
41	532 12 61-97	Washer 1-1/2 OD x 15/32 ID x .250
42	810 04 07-00	Washer Lock 7/16
45	873 51 04-00	Nut Keps Hex 1/4-20 unc
62	532 43 40-17	Shield Heat Muffler
69	532 16 53-91	Gasket
70	581 88 11-01	Tube Exhaust LH
71	581 88 10-01	Tube Exhaust RH
79	532 18 39-06	Screw Socket HD 5/16-18 x 1
84	817 06 06-20	Screw 3/8-16 x 1-1/4
85	532 17 99-53	Bolt 7/16-20 x 3.75 Gr. 5
87	532 17 18-77	Bolt 5/16-18 unc x 3/4 w/Sems
90	817 00 06-16	Screw 3/8-16 x 1
91	532 18 74-95	Bushing
116	539 13 26-24	Knob Soft Touch
117	532 42 08-28	Valve Fuel Reserve

NOTE: All component dimensions given in U.S. inches
1 inch = 25.4 mm

For engine service and replacement parts, call the toll free number for your engine manufacturer listed below:

Briggs & Stratton 1-800-233-3723

Engine Power Rating Information

The gross power rating for individual gas engine models is labeled in accordance with SAE (Society of Automotive Engineers) code J1940 (Small Engine Power & Torque Rating Procedure), and rating performance has been obtained and corrected in accordance with SAE J1995 (Revision 2002-05). Torque values are derived at 3060 RPM; horsepower values are derived at 3600 RPM. Actual gross engine power will be lower and is affected by, among other things, ambient operating conditions and engine-to-engine variability. Given both the wide array of products on which engines are placed and the variety of environmental issues applicable to operating the equipment, the gas engine will not develop the rated gross power when used in a given piece of power equipment (actual “on-site” or net power). This difference is due to a variety of factors including, but not limited to, accessories (air cleaner, exhaust, charging, cooling, carburetor, fuel pump, etc.), application limitations, ambient operating conditions (temperature, humidity, altitude), and engine-to-engine variability. Due to manufacturing and capacity limitations, Briggs & Stratton may substitute an engine of higher rated power for this Series engine.

TRACTOR - MODEL NO. GTH27V48LS (96043011702), PRODUCT NO. 960 43 01-17
STEERING ASSEMBLY

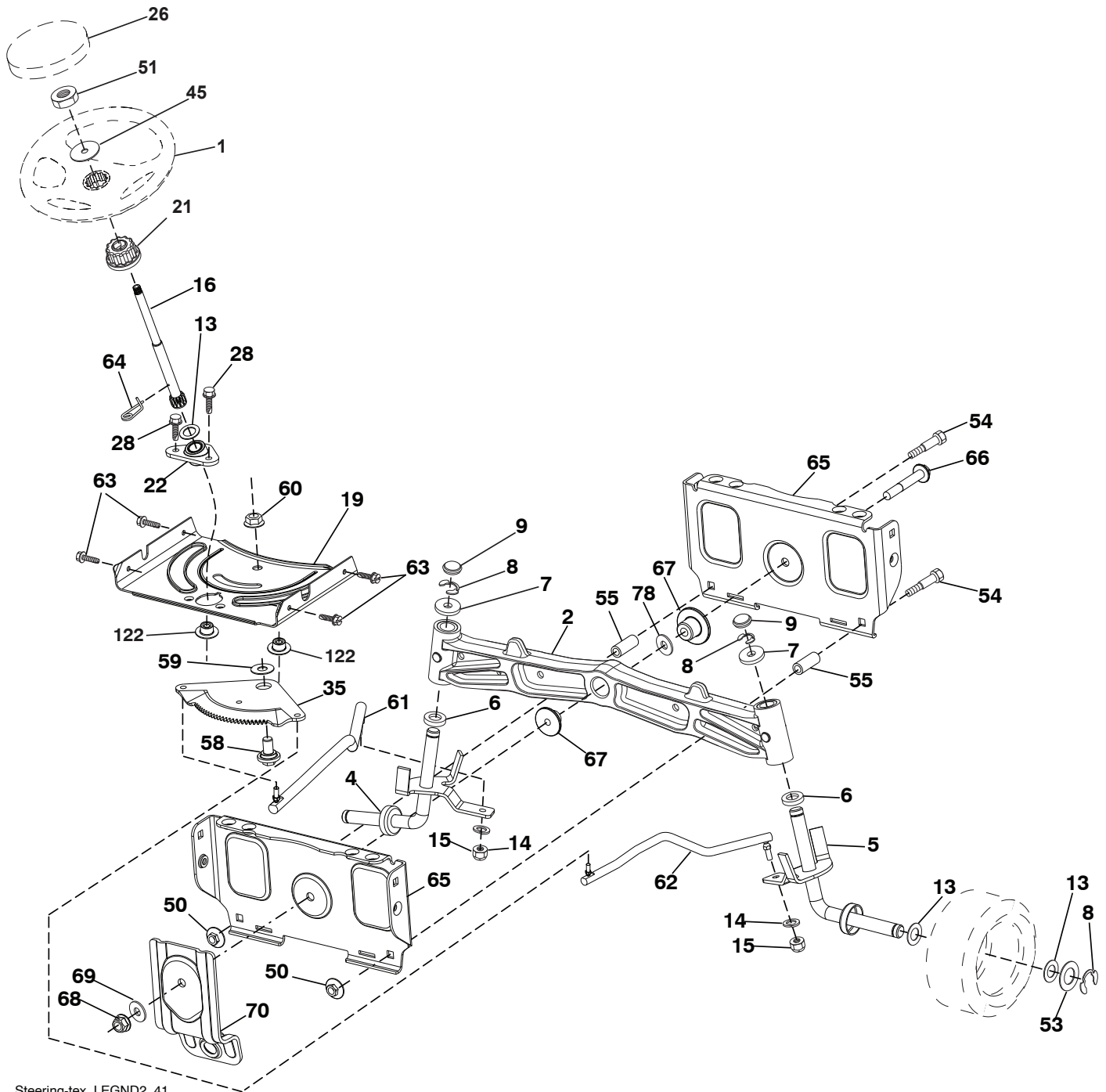

Steering-tex_LEGND2_41

**TRACTOR - MODEL NO. GTH27V48LS (96043011702), PRODUCT NO. 960 43 01-17
STEERING ASSEMBLY**

KEY NO.	PART NO.	DESCRIPTION
1	532 43 97-40	Wheel, Steering
2	532 19 59-68	Axle Asm., Front
4	532 40 30-89	Spindle Asm. LH
5	532 40 30-90	Spindle Asm. RH
6	532 12 49-31	Bearing, Race Thrust Harden
7	532 12 17-48	Washer 25/32 x 1-5/8 x 16 Ga.
8	812 00 00-29	Ring, Clip #T5304-75
9	532 12 12-32	Cap, Spindle
13	532 12 17-49	Washer 25/32 x 1-1/4 x 16 Ga.
14	810 04 06-00	Washer, Lock Hvy Hlcl Spr 3/8
15	873 54 06-00	Nut, Crown Lock 3/8-24 unf
16	532 40 82-19	Shaft Steering
19	532 19 47-29	Plate Steering
21	532 18 67-37	Adapter, Wheel Steering
22	532 42 05-37	Steering Support Lower
26	532 43 97-43	Insert, Wheel Steering
28	817 00 06-12	Screw 3/8-16 x 3/4
35	532 19 47-32	Gear, Sector Plate
45	819 18 38-12	Washer 9/16 x 2-3/8 x 12 Ga.
50	873 90 06-00	Nut Lock Flange 3/8-16 unc
51	873 94 08-00	Nut Hex Jam Toplock 1/2-20 unf
53	532 18 89-67	Washer Hardened .793 x 1.637 x .060
54	874 76 06-36	Bolt Hex 3/8-16 unc x 2-1/4
55	532 41 47-36	Spacer
58	532 19 47-47	Bolt Shoulder Sector Pivot CFM
59	532 19 47-48	Washer Thrust Sector Steering
60	873 97 10-00	Nut Flange Lock 5/8-11
61	532 19 47-40	Draglink, LH
62	532 19 47-41	Draglink, RH
63	817 00 05-12	Screw 5/16-18 x 3/4
64	532 19 98-49	Retainer Clip Spring Steering
65	532 19 47-34	Brace Axle Front
66	871 02 07-48	Bolt Hex Fghd 7/16-14 x 3 Serr
67	532 19 47-37	Bushing PM Front Axle
68	873 90 07-00	Nut Lock Flange 7/16-14 Gr. 5
69	532 19 91-62	Washer 1.5 x .505 x .118
70	532 19 61-97	Bracket Deck Susp. Front
78	532 05 70-79	Washer Thrust
122	532 44 49-62	Cap Gear Sector

NOTE: All component dimensions given in U.S. inches
1 inch = 25.4 mm

TRACTOR - MODEL NO. GTH27V48LS (96043011702), PRODUCT NO. 960 43 01-17
MOWER DECK

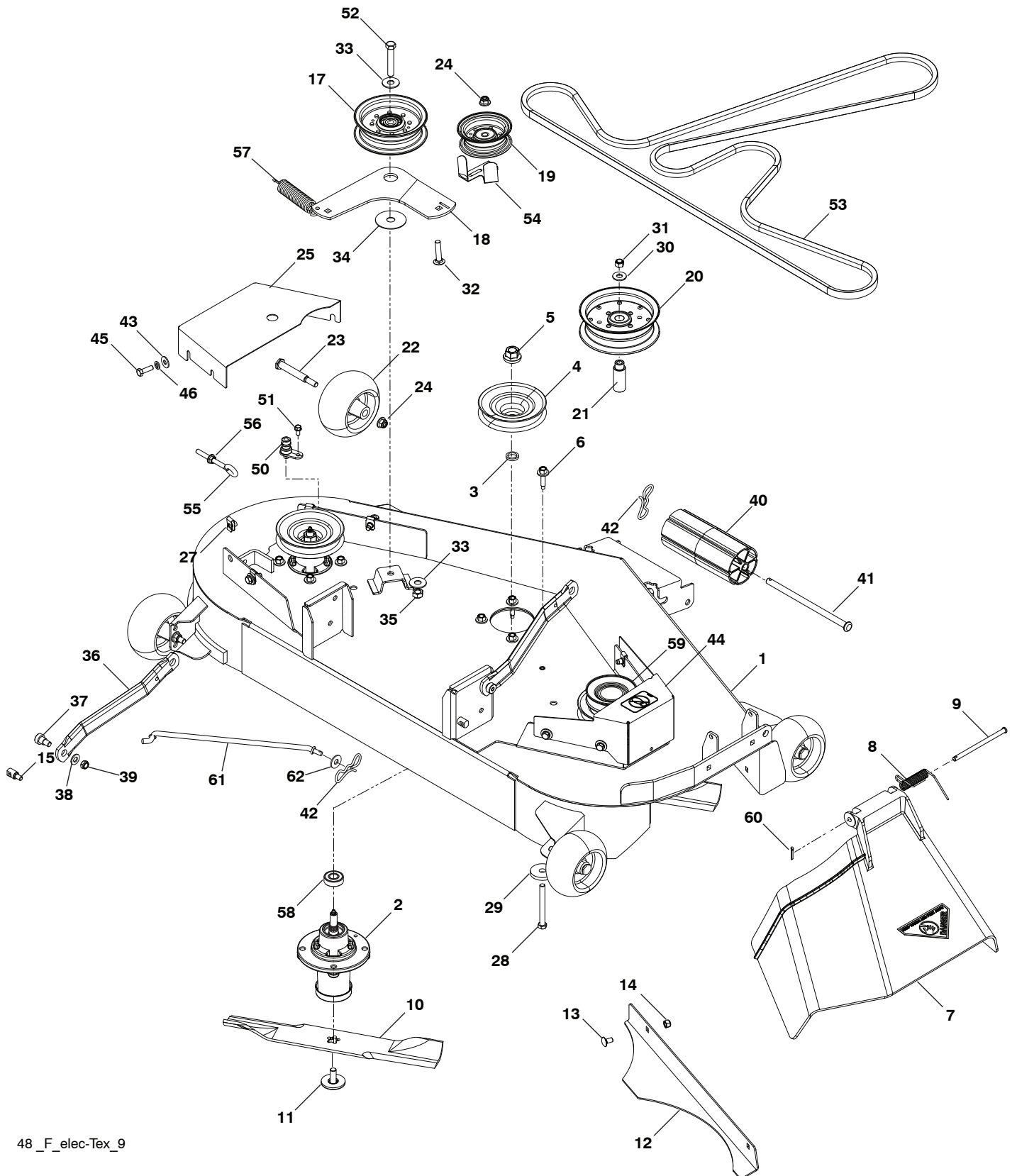

48_F_elec-Tex_9

**TRACTOR - MODEL NO. GTH27V48LS (96043011702), PRODUCT NO. 960 43 01-17
MOWER DECK**

KEY NO.	PART NO.	DESCRIPTION	KEY NO.	PART NO.	DESCRIPTION
1	594 73 07-01	Kit SVC Deck	35	873 90 07-00	Nut, 7/16-14 Hex Nyloc
2	539 11 21-70	Housing Assembly	36	532 19 51-85	Arm, Susp., Rear
3	532 18 76-90	Washer-Spacer	37	539 11 36-21	Sb 3/8-16 x 3/8 Skt Hd
4	532 17 43-75	Pulley, Mandrel	38	819 13 13-16	Washer, 13/32 x 13/16 x 16 Ga.
5	532 40 02-34	Nut, 9/16 Top Center Lock	39	539 20 02-82	Nut, 3/8-16 Hex Jam Nyloc
6	532 17 39-84	Screw, Washer Head	40	532 17 60-66	Nose Roller
7	539 11 07-32	Discharge Chute, 48"	41	532 17 91-27	Rod Roller Nose
8	539 11 07-35	Spring - Torsion	42	532 19 42-08	Pin Cotter 5/16 Bow Tie Lock
9	539 11 07-36	Pin, Clevis 5/16 x 5.19	43	819 12 14-14	Washer, 3/8 x 7/8 x 14 Ga.
10	539 11 34-25	Blade, 16-1/4"	44	575 96 72-02	Shield, Belt Rh
11	532 19 30-03	Bolt/Washer Asm 7/16-20	45	874 78 05-16	Hcs 5/16-18 x 1
12	539 11 34-26	Confinement Plate	46	810 03 05-00	Wash 5/16 Slw
13	872 11 05-05	Bolt Carr. 5/16-18 x 5/8	50	532 41 55-98	Washout Port
14	873 80 05-00	Nut 5/16-18	51	817 49 04-08	Bolt, 1/4-20 x 1/2
15	532 19 51-61	Stud, Fasten w/ Anti- Rotate	52	874 78 07-40	Bolt, 7/16-14 x 2-1/2
17	532 19 61-04	Pulley, Idler Spec. Hub	53	574 84 56-02	Belt, Deck
18	574 82 71-02	Arm, Idler, Blk	54	532 14 10-43	Guard, Belt
19	532 17 79-68	Pulley, Idler	55	539 11 55-74	Eyebolt 5/16 x 3-1/2
20	539 13 27-28	Pulley, Idler	56	873 90 05-00	Nut 5/16-18 Hex Whizlk
21	575 22 45-01	Idler Bushing	57	539 10 68-50	Spring
22	532 13 39-57	Wheel, Gauge	58	532 11 04-85	Ball Bearing
23	532 19 34-06	Bolt, Shoulder	59	575 35 29-01	Pulley
24	521 99 65-01	Nut 3/8-16 Hex Flg Nyloc	60	532 16 94-84	Clip Retainer
25	575 22 47-02	Shield, Belt LH	61	532 40 03-37	Rod Anti-Sway
27	539 10 47-63	Retainer 5/16c U Type	62	819 13 13-12	Washer 13/32 x 13/16 x 12 Ga.
28	539 10 82-71	Hcs 3/8-16 x 3-1/2 Gr 5	--	594 73 07-01	Kit SVC Deck
29	539 10 65-04	Heavy Washer			
30	819 14 16-14	Washer, 3/8 Flat Std			
31	539 97 69-79	Nut 3/8-16 Hex Nyloc			
32	539 99 09-23	Rhsnb 3/8-16 x 1-3/4 Gr 5			
33	539 10 48-64	Washer, 7/16 Flat			
34	532 17 85-15	Washer, Flat Hardened			

NOTE: All component dimensions given in U.S. inches
1 inch = 25.4 mm

**TRACTOR - MODEL NO. GTH27V48LS (96043011702), PRODUCT NO. 960 43 01-17
MOWER LIFT**

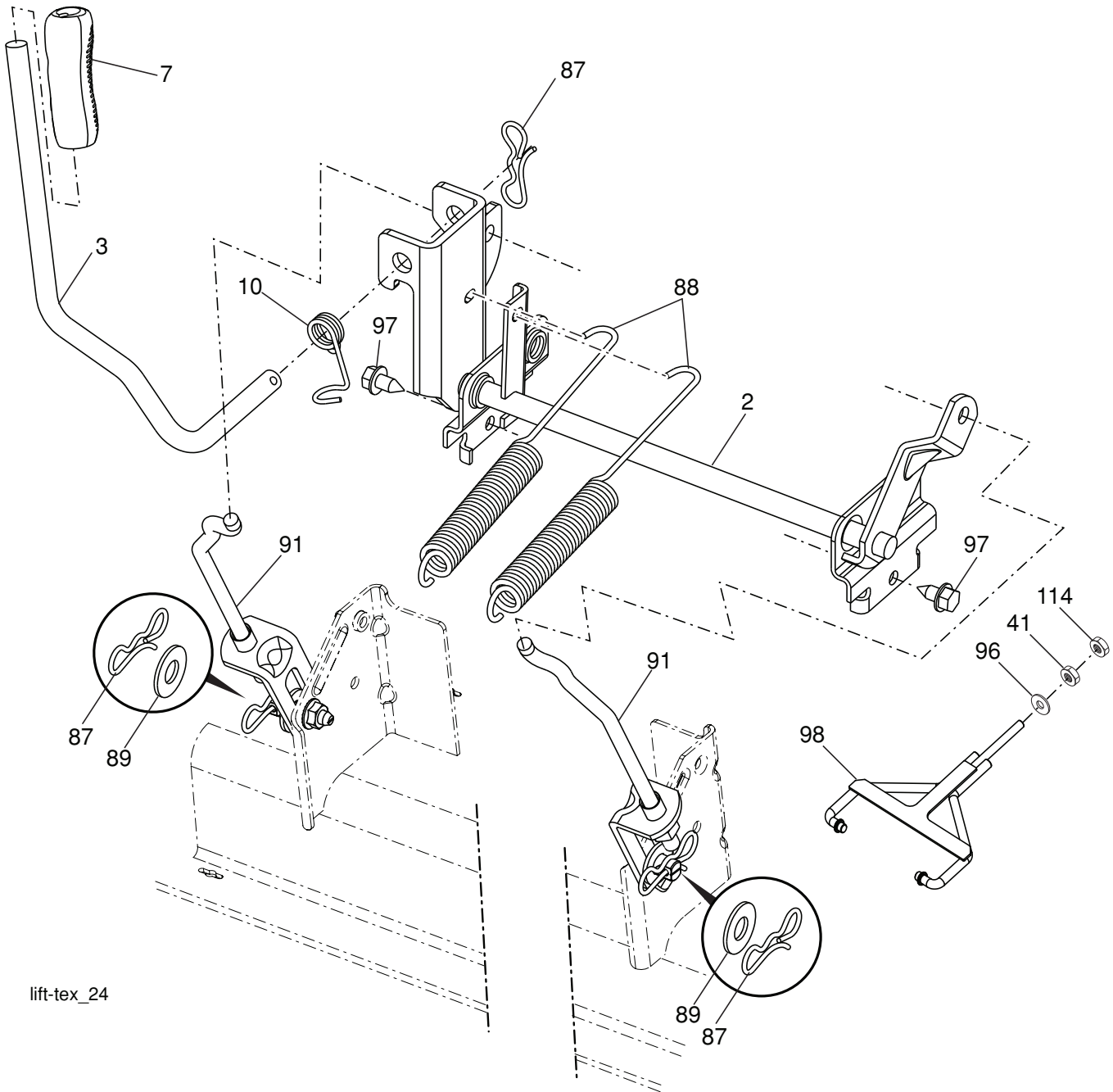

lift-tex_24

KEY NO.	PART NO.	DESCRIPTION
2	532 42 20-27	Shaft Asm., Lift
3	532 19 52-30	Lever Asm., Lift RH
7	580 96 23-01	Grip, Lever
10	532 19 63-14	Spring Torsion
41	532 17 59-94	Nut Lift Link
87	532 19 42-09	Pin Cotter 7/16 Bow Tie Lock
88	532 19 53-04	Spring Lift Assist
89	819 19 19-12	Washer Clear Zinc

KEY NO.	PART NO.	DESCRIPTION
91	532 40 34-07	Link Lift Susp Mower Rear
96	532 19 52-63	Bushing Spherical
97	817 00 06-12	Screw 3/8-16 x .75
98	574 82 25-01	Link Lift Susp. Front Mower
114	873 36 07-00	Nut Jam 7/16-20

NOTE: All component dimensions given in U.S. inches
1 inch = 25.4 mm

**TRACTOR - MODEL NO. GTH27V48LS (96043011702), PRODUCT NO. 960 43 01-17
SEAT ASSEMBLY**

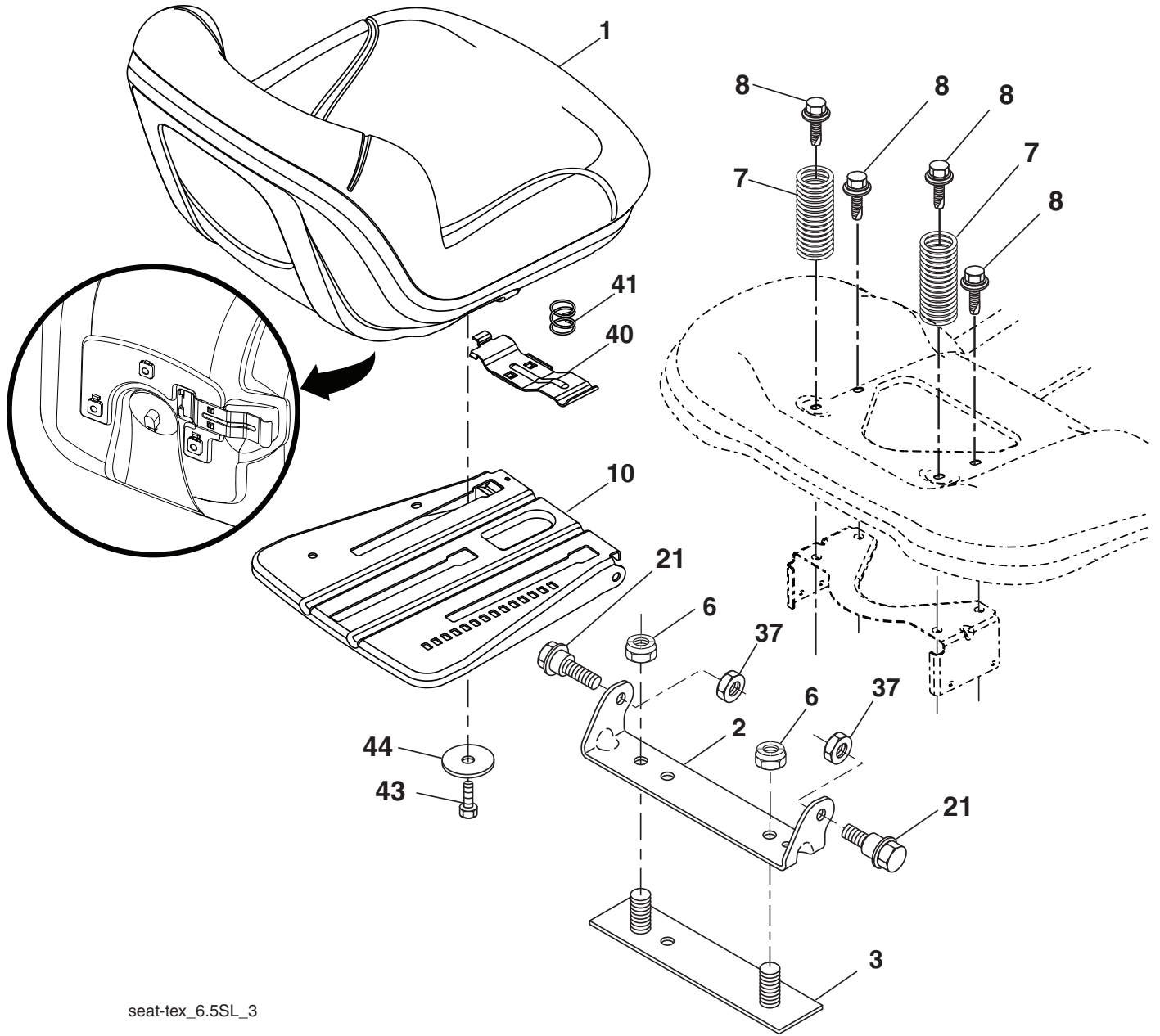

seat-tex_6.5SL_3

KEY NO.	PART NO.	DESCRIPTION
1	532 44 32-63	Seat
2	532 18 01-66	Bracket Pivot Fender
3	532 14 06-75	Strap, Asm Fender
6	873 80 06-00	Nut, Lock w/Ins. 3/8-16 unc
7	532 12 41-81	Spring, Seat Cprsn
8	532 17 18-77	Bolt 5/16-18 unc x 3/4 w/Sems
10	532 19 69-77	Pan, Seat
21	532 17 18-52	Bolt, Shoulder 5/16-18

KEY NO.	PART NO.	DESCRIPTION
37	873 80 05-00	Nut, Lock 5/16-18 unc
40	532 43 98-71	Handle Slide Seat
41	532 19 82-00	Spring Latch Seat
43	874 76 06-12	Bolt Fin Hex 3/8-16 unc x 3/4
44	819 13 38-12	Washer 13/32 x 2-3/8 x 12 Ga.

NOTE: All component dimensions given in U.S. inches
1 inch = 25.4 mm

**TRACTOR - MODEL NO. GTH27V48LS (96043011702), PRODUCT NO. 960 43 01-17
DECALS**

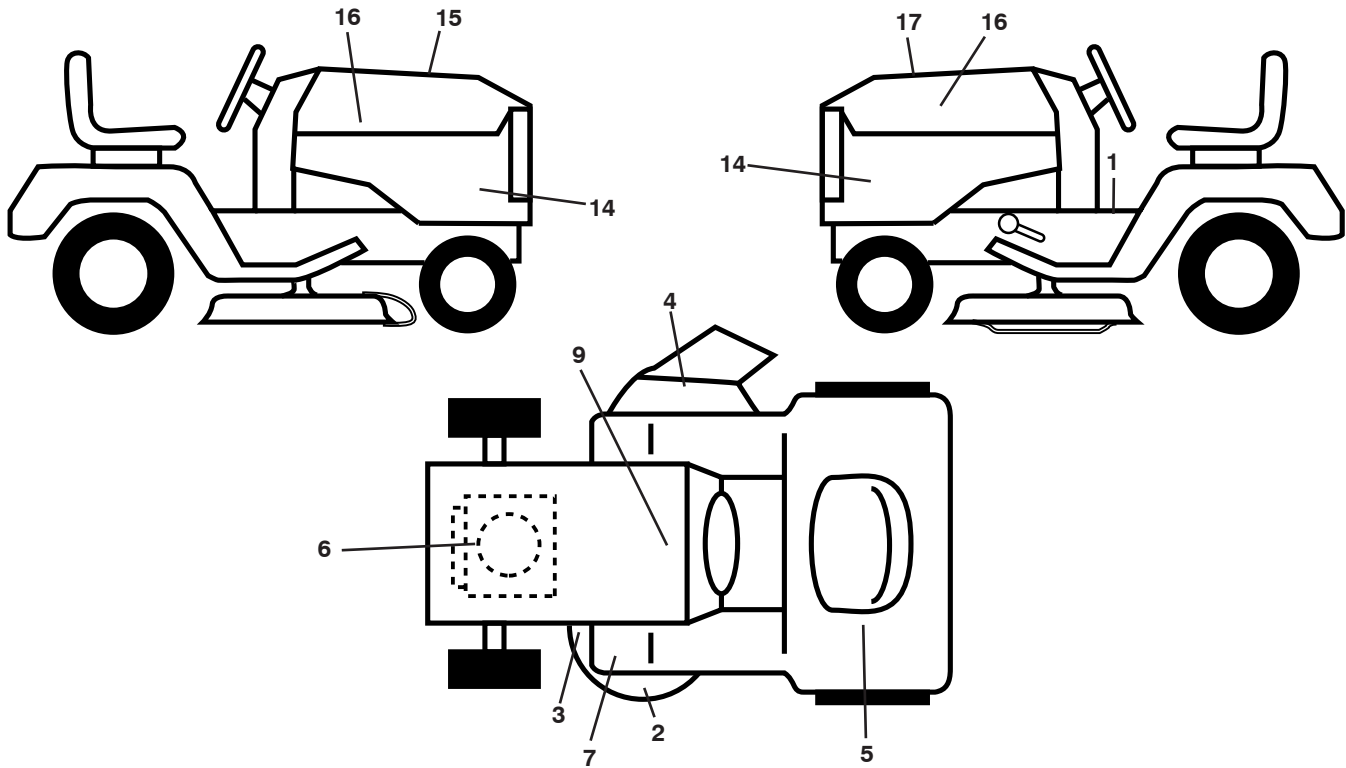

KEY NO.	PART NO.	DESCRIPTION
1	532 41 16-57	Decal, Operator's
2	581 72 43-01	Decal, No Step
3	532 19 87-85	Decal, Mower Schematic
4	539 11 32-24	Decal, Warning
5	532 42 62-09	Decal, Warning Reserve
6	532 43 29-18	Decal, Eng. H.P.
7	532 41 86-00	Decal, Pedal
9	532 14 50-05	Decal, Battery Dnge/Poi

KEY NO.	PART NO.	DESCRIPTION
14	532 43 87-17	Decal, Panel Side
15	532 42 38-29	Decal, Cust. Resp.
16	581 62 73-01	Decal, Hood Logo
17	532 43 84-75	Decal, Replacement
--	532 16 69-60	Decal, Bypass
--	532 43 98-82	Pad, Footrest, LH
--	532 43 98-81	Pad, Footrest, RH
--	532 44 51-46	Manual, Operator's (Eng/Span)
--	532 44 53-38	Manual, Parts (Eng/Span)

WHEELS AND TIRES

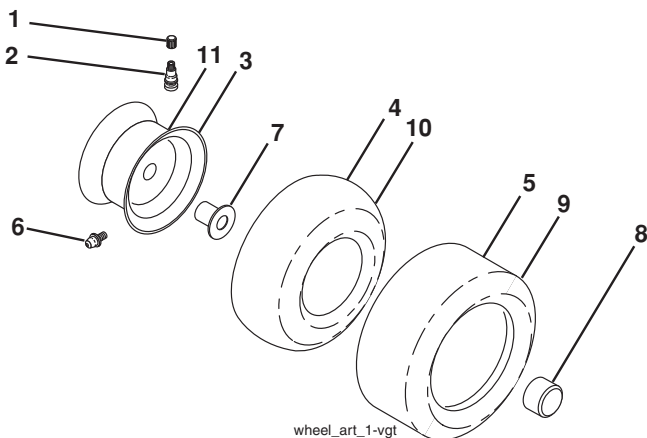

KEY NO.	PART NO.	DESCRIPTION
1	532 05 91-92	Cap, Valve, Tire
2	532 06 51-39	Stem, Valve
3	532 18 18-39	Rim Assembly, Front
4	532 00 81-34	Tube, Front (Service Item Only)
5	532 16 10-24	Tire, Front
6	532 12 49-57	Fitting, Grease (Front Wheel Only)
7	532 12 49-59	Bearing, Flange (Front Wheel Only)
8	532 17 50-39	Cap, Axle
9	532 17 04-53	Tire, Rear
10	532 00 71-54	Tube, Rear (Service Item Only)
11	532 14 45-10	Rim Assembly, Rear
--	532 14 43-34	Sealant, Tire (10 oz. Tube)

NOTE: All component dimensions given in U.S. inches
1 inch = 25.4 mm

TRACTOR - - MODELO NO. GTH27V48LS (96043011702), PRODUCT NO. 960 43 01-17 DIAGRAMA

SCH12-s

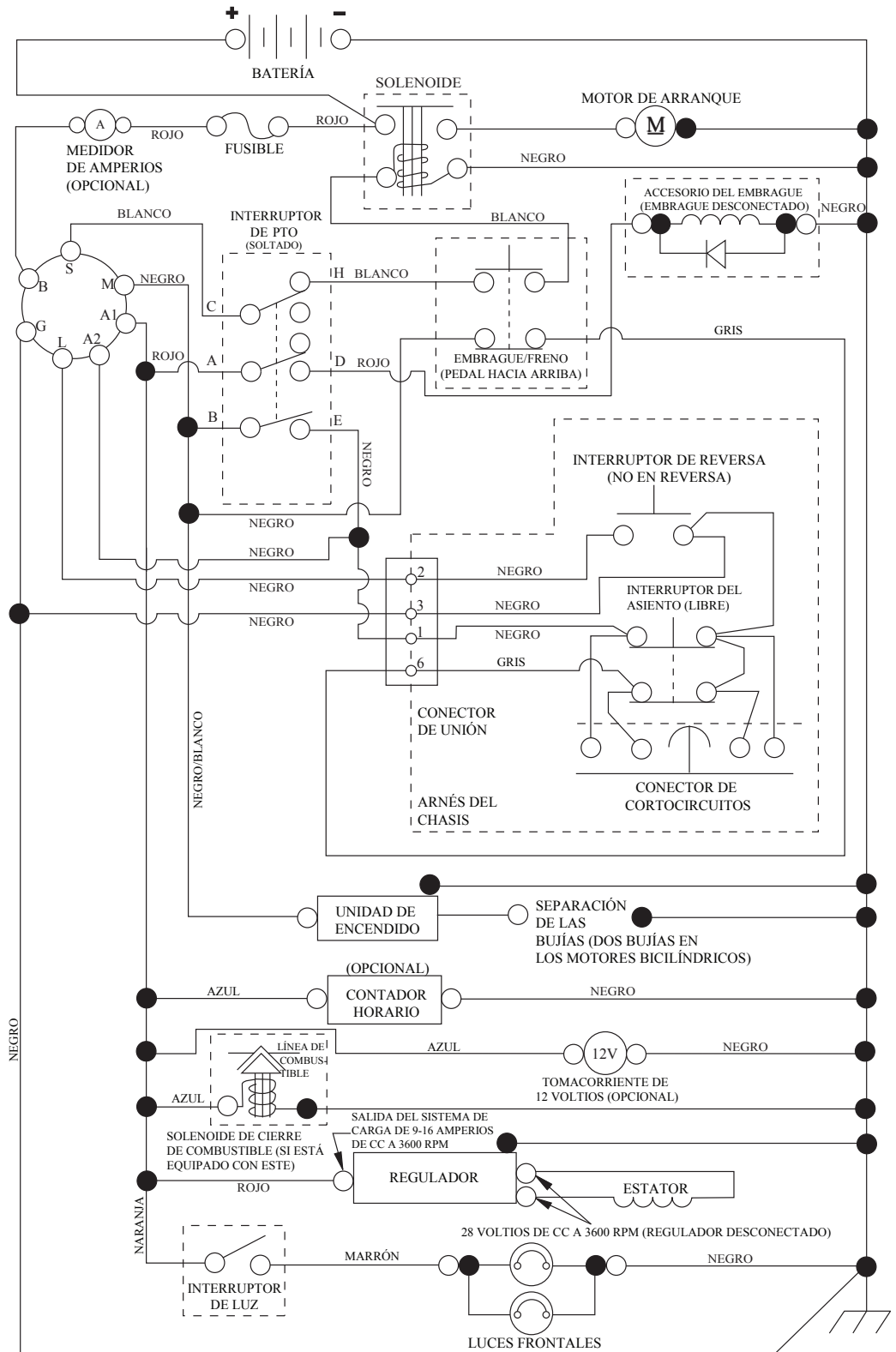

INTERRUPTOR DE PTO
(CARA DE ACOPLAMIENTO)

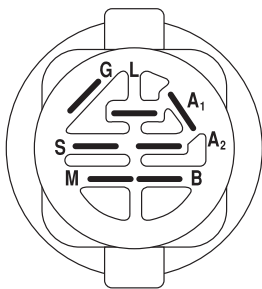

INTERRUPTOR DE ENCENDIDO

POSICIÓN	CIRCUITO «MARCA»
APAGADO	M+G+A1
PONER EN FUNCIONAMIENTO/ANULAR	B+A1
PONER EN FUNCIONAMIENTO	B+A1 L+A2
ARRANCAR	B + S + A1

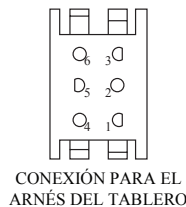

NOTA SOBRE LAS ABRAZADERAS DE AISLAMIENTO DEL CABLEADO: SI SE QUITAN LAS ABRAZADERAS DE AISLAMIENTO DEL CABLEADO PARA HACER EL MANTENIMIENTO DE LA UNIDAD, SE LAS DEBERÁ INSTALAR NUEVAMENTE PARA PROTEGER EL CABLEADO ADECUADAMENTE.



TRACTOR -- MODELO NO. GTH27V48LS (96043011702), PRODUCT NO. 960 43 01-17
DIAGRAMA ELÉCTRICO

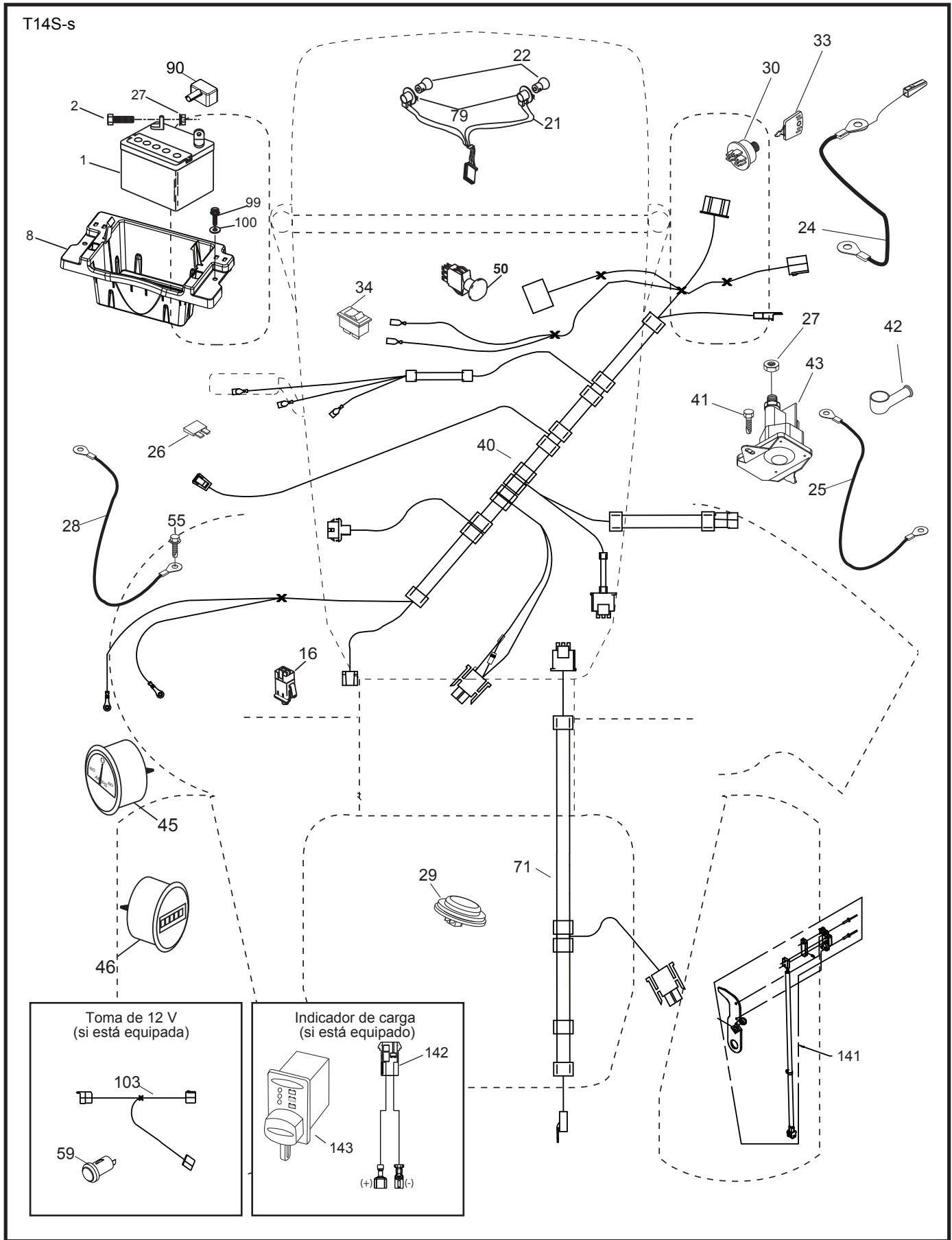

**TRACTOR - - MODELO NO. GTH27V48LS (96043011702), PRODUCT NO. 960 43 01-17
DIAGRAMA ELÉCTRICO**

CÓDIGO PIEZA		DESCRIPCIÓN
No.	No.	
1	532 16 34-65	Batería
2	874 76 04-12	Perno de cabeza hexagonal de 1/4-20 x 3/4
8	532 18 64-91	Caja de la batería
16	532 17 61-38	Interruptor corta corriente a presión
21	532 40 02-52	Cableado del enchufe para la luz
22	532 00 41-52	Bombilla de luz #1156
24	532 40 02-53	Cable de Batería
25	532 41 28-95	Cable
26	532 17 51-58	Fusible
27	873 51 04-00	Tuerca 1/4-20 unc
28	532 14 54-91	Cable a tierra 21" negro 6 Ga.
29	532 40 15-45	Interruptor del asiento
30	532 19 33-50	Interruptor de encendido
33	532 41 19-33	Llave/cadena
34	532 11 07-12	Interruptor de luz/de restauración
40	532 42 90-83	Cableado del tablero de encendido
41	817 72 04-08	Tornillo 1/4-20 unc x 1/2
42	532 13 15-63	Cubierta de la terminal
43	532 19 25-07	Solenoides
45	532 42 52-70	Indicador amperímetro
46	532 42 52-71	Indicador cronómetro
50	532 17 46-51	Interruptor PTO
55	817 06 05-12	Tornillo 5/16-18 x 3/4
59	532 40 03-03	Salida 12-V
71	532 19 42-76	Cableado de encendido
79	532 17 52-42	Enchufe de cierre por torsión del ensamble de la bombilla
90	532 43 53-95	Tapa de los bornes de la batería
91	532 19 02-70	Correa de Batería
99	817 67 04-12	Tornillo 1/4-20 x 3/4
100	819 09 14-16	Arandela 9/32 x 7/8 x 16 Ga.
103	532 42 17-47	Cableado
141	532 42 12-25	Juego G700/G730 ROS

NOTA: Las dimensiones de todos los componentes están expresadas en pulgadas americanas. 1 pulgada = 25,4 mm

TRACTOR -- MODELO NO. GTH27V48LS (96043011702), PRODUCT NO. 960 43 01-17
CHASIS

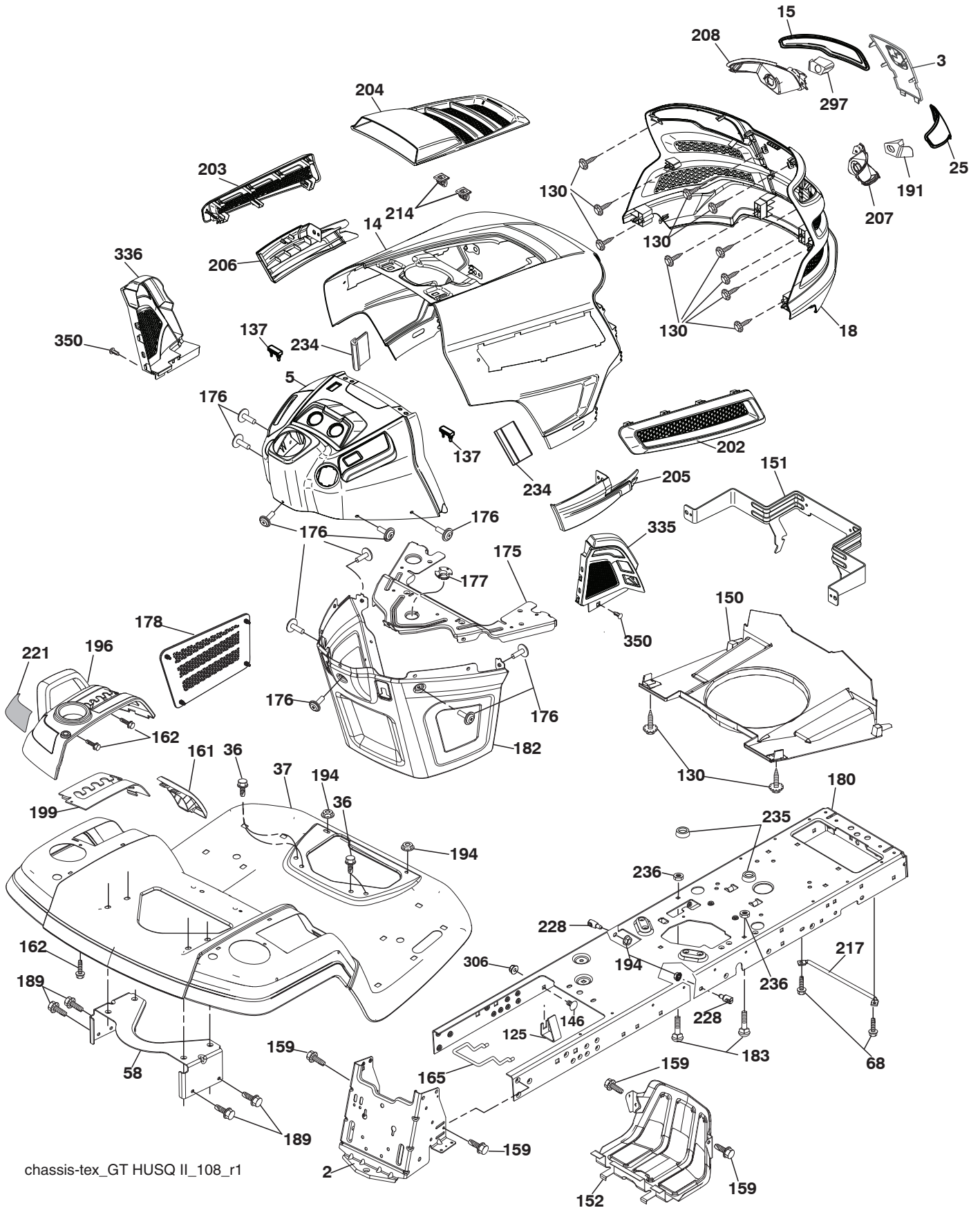

chassis-tex_GT HUSQ II_108_r1

TRACTOR - - MODELO NO. GTH27V48LS (96043011702), PRODUCT NO. 960 43 01-17 CHASIS

CÓDIGO PIEZA		DESCRIPCIÓN
No.	No.	
2	580 43 44-01	Barra de tracción
3	532 43 97-52	Aplica
5	532 43 74-77	Tablero
14	532 44 11-77	Capota
15	532 43 97-33	Lente izquierdo de la parrilla
18	532 44 06-53	Parrilla
25	532 44 33-85	Lente derecho de la parrilla
36	817 06 05-12	Tornillo 5/16-18 x 3/4
37	532 44 12-08	Guardabarros
58	532 19 43-14	Soporte
68	817 49 05-08	Tornillo 5/16-18 x 1/2
125	581 68 48-01	Soporte
130	532 41 63-58	Tornillo #10 x 0.750
137	532 40 75-90	Cubierta Tablero
146	581 85 79-01	Perno
150	532 43 97-74	Cubierta térmica del conducto
151	532 43 66-70	Soporte
152	532 43 98-70	Protector contra oscurecimiento
159	817 00 06-12	Tornillo 3/8-16 x 3/4
161	532 43 99-29	Ventana
162	532 14 24-32	Tornillo 1/4 x 1/2
165	532 19 43-30	Soporte
175	532 19 63-04	Travesaño
176	532 40 07-76	Tornillo 10-24 x 5/8
177	532 19 52-27	Buje de soporte del guardabarros de carga
178	532 19 97-82	Carga la asamblea neta
180	532 44 55-59	Chasis
182	532 40 68-59	Tablero
183	874 52 05-20	Perno 5/16-18 x 1-1/4
189	817 00 05-12	Tornillo 5/16-18 x 3/4

CÓDIGO PIEZA		DESCRIPCIÓN
No.	No.	
191	532 43 74-55	Parrilla reflector LD
194	873 90 05-00	Tuerca 5/16-18
196	532 43 96-74	Ensamble de la consola de la plataforma de elevación
199	532 19 82-59	Plataforma de elevación
202	532 43 97-28	Salida de Ventilación (LD)
203	532 43 97-27	Salida de Ventilación (LI)
204	532 43 57-14	Salida de Ventilación superior
205	532 43 97-30	Camisa de Capota (LD)
206	532 43 97-29	Camisa de Capota (LI)
207	532 43 97-34	Bisel derecho
208	532 43 97-35	Bisel izquierdo
214	532 19 91-45	Cierre
217	532 40 91-67	Varilla giratoria
221	532 19 89-09	Reflector LI
228	532 19 51-61	Sujetador del travesaño
234	532 40 47-42	Cubierta Capota
235	532 40 61-29	Separador del guardabarros
236	873 93 05-00	Tuerca 5/16-18 unc
297	532 43 74-56	Parrilla reflector LI
306	873 90 06-00	Tuerca
335	532 44 82-04	Cubierta ld
336	532 44 53-09	Cubierta li
350	532 44 51-43	Clip del árbol de navidad
--	532 42 49-18	Kit del protector del cepillo

NOTA: Las dimensiones de todos los componentes están expresadas en pulgadas americanas. 1 pulgada = 25,4 mm

TRACTOR - - MODELO NO. GTH27V48LS (96043011702), PRODUCT NO. 960 43 01-17
TRANSMISIÓN

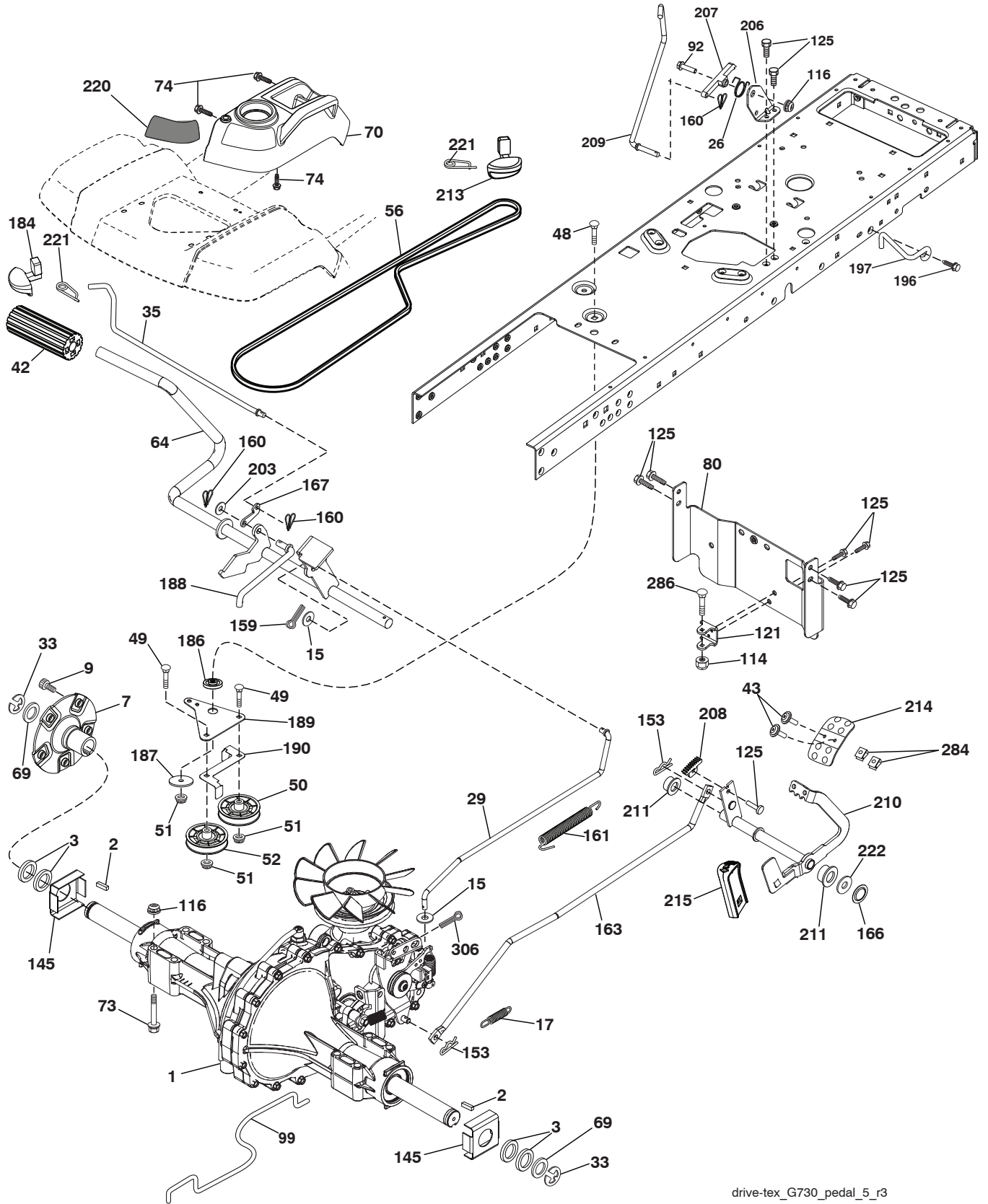

drive-tex_G730_pedal_5_r3

TRACTOR - - MODELO NO. GTH27V48LS (96043011702), PRODUCT NO. 960 43 01-17 TRANSMISIÓN

CÓDIGO No.	PIEZA No.	DESCRIPCIÓN	CÓDIGO No.	PIEZA No.	DESCRIPCIÓN
1	---	Transeje, Hydro G7-BCBB-1XDC-1FCA (420331) (Haga el pedido de las piezas al fabricante del transeje.)	161	532 10 57-09	Resorte de retorno del embrague
2	532 00 70-70	Cuña 1/4 x 2.5	163	532 41 81-85	Varilla de control del pedal
3	532 00 75-63	Arandela	166	532 42 91-64	Tuerca .625
7	532 19 98-37	Ruede eje la asamblea	167	532 40 52-57	Pestillo del freno de mano
9	532 14 00-80	Perno	184	532 44 14-55	Manija del freno de mano
15	819 13 13-16	Arandela 13/32 x 13/16 x 16 Ga.	186	532 19 43-21	Espaciador de retención
17	532 19 72-96	Resorte de freno	187	819 13 32-10	Arandela
26	532 19 96-79	Crucero con retorno de muelle	188	532 19 43-23	Mecanismo de desplazamiento de la varilla de mando del embrague
29	532 41 81-86	Varilla del freno	189	532 40 75-04	Palanca acodada del mecanismo de desplazamiento
33	812 00 00-53	Aro E	190	532 40 75-05	Sujetador de la palanca acodada del mecanismo de desplazamiento
35	583 86 45-01	Varilla del freno de mano	196	817 00 06-16	Tornillo 3/8-16 x 1
42	532 12 48-72	Cubierta del pedal	197	532 19 97-69	Bracket Clutch Anti-Rotation
43	874 18 04-12	Tornillo 1/4-20 x 3/4	203	819 11 11-16	Arandela 11/32 x 11/16 x 16 Ga.
48	872 11 06-12	Perno 3/8-16 x 1-1/2 Gr.5	206	532 19 78-67	Soporte
49	872 11 06-14	Perno	207	532 19 78-68	Bloqueo del control del crucero
50	532 19 43-27	Polea loca plana	208	532 19 78-69	Engranaje del sector de control del crucero
51	873 90 06-00	Tuerca 3/8-16	209	532 19 95-92	Varilla de control del crucero
52	532 19 43-26	Polea loca con ranura en V con un desplazamiento	210	532 19 78-60	Ensamble del balancín del control del pedal
56	532 42 08-07	Correa trapezoidal de la transmisión	211	532 12 01-83	Rodamiento de nylon
64	532 19 78-65	Ensamble del eje Control del pedal de freno	213	532 40 31-19	Perilla de control del crucero
69	532 12 38-00	Arandela 1-1/32 x 1-5/8 x 16 Ga.	214	532 41 68-63	Forro del pedal para avanzar
70	532 43 96-61	Ensamble del console	215	532 40 17-23	Forro del pedal para retroceder
73	874 49 05-48	Perno 5/16-18 x 3 Gr. 5	220	532 19 89-08	Reflector LD
74	532 14 24-32	Tornillo 1/4 x 1/2	221	532 40 31-87	Abrazadera de retención del resorte de la manija
80	532 41 81-84	Correa de torsión	222	879 21 20-10	Arandela 21/32 x 1-1/4 x 10 Ga.
92	874 76 05-20	Perno 5/16-18 x 1/2	284	532 41 76-93	Tuerca 1/4-20
99	532 41 81-88	Resorte	286	872 01 05-20	Perno 5/16-18 x 2.50
114	873 80 05-00	Tuerca 5/16-18 unc	306	876 02 04-16	Pasador de chaveta de 1/8 x 1
116	873 90 05-00	Tuerca 5/16-18			
121	532 17 56-11	Soporte			
125	817 00 05-12	Tornillo 5/16-18 x 3/4			
145	532 16 31-68	Arandela			
153	532 12 47-88	Retén del resorte			
159	876 02 04-12	Pasador de chaveta de 1/8 x 3/4			
160	532 16 94-84	Abrazadera de retención			

NOTA: Las dimensiones de todos los componentes están expresadas en pulgadas americanas. 1 pulgada = 25,4 mm

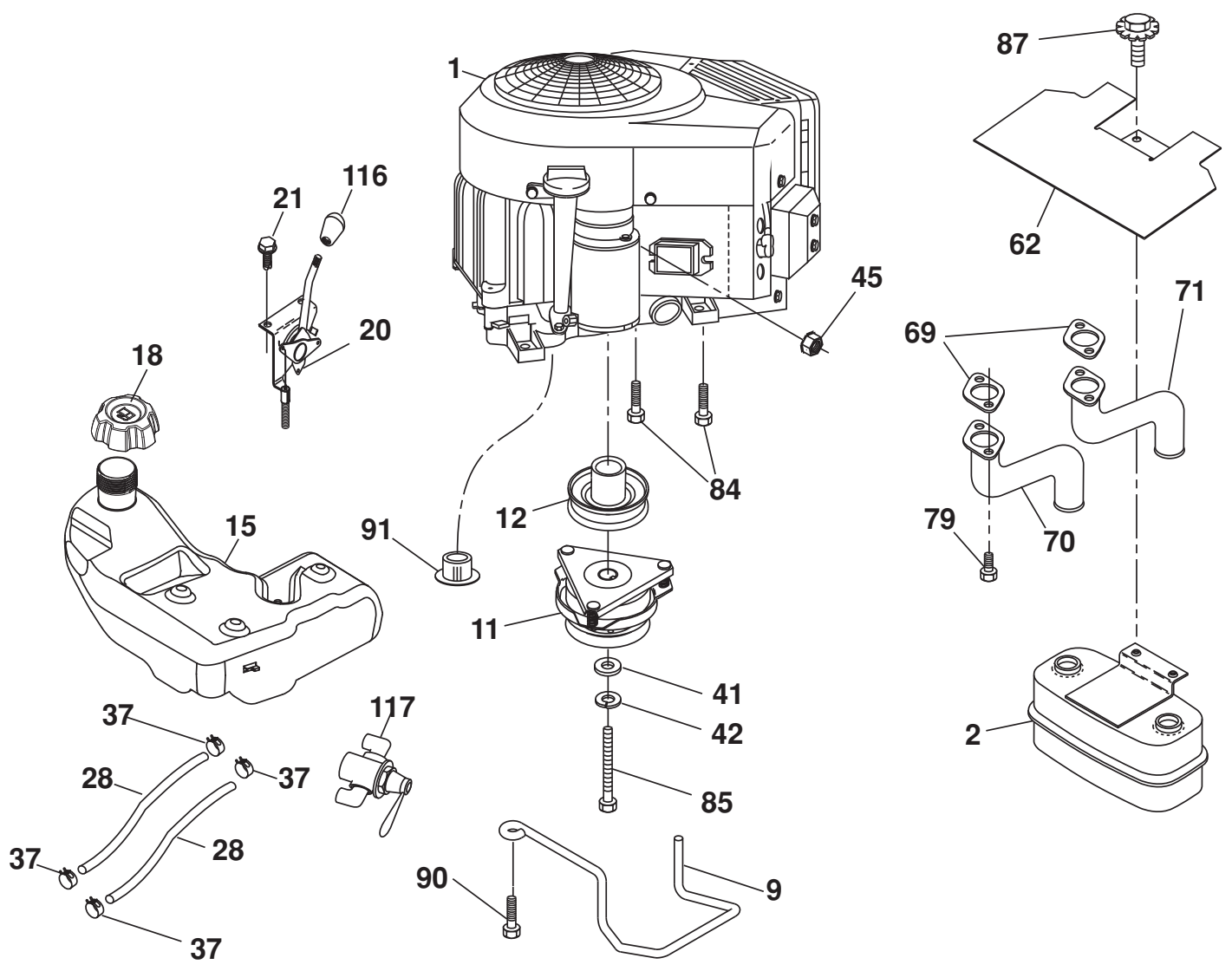

EQUIPO APAGACHISPAS

engine-tex_bs-2cyl_26

TRACTOR - - MODELO NO. GTH27V48LS (96043011702), PRODUCT NO. 960 43 01-17 MOTOR

CÓDIGO No.	PIEZA No.	DESCRIPCIÓN
1	- - - - -	Motor B&S Modelo No. 44Q777-2406-G1 (438243) (Haga el pedido de las piezas al fabricante del motor.)
2	532 44 59-62	Silenciador
9	532 40 86-67	Ensamble del sujetador de la correa del motor
11	532 17 93-35	Embrague eléctrico
12	532 19 43-43	Polea del motor
15	532 43 80-82	Tanque de combustible de 4,0R
18	532 43 92-08	Ensamble de la tapa
20	532 42 43-41	Control del regulador
21	532 41 63-58	Tornillo #10 x 0.750
28	532 40 11-35	Línea de combustible
29	532 13 71-80	Equipo apagachispas
37	532 12 34-87	Abrazadera de la manguera
41	532 12 61-97	Arandela 1-1/2 OD x 15/32 ID x .250
42	810 04 07-00	Arandela
45	873 51 04-00	Tuerca 1/4-20 unc
62	532 43 40-17	Silenciador con pantalla térmica
69	532 16 53-91	Junta
70	581 88 11-01	Tubo de escape izquierdo
71	581 88 10-01	Tubo de escape derecho
79	532 18 39-06	Tornillo 5/16-18 x 1
84	817 06 06-20	Tornillo 3/8-16 x 1-1/4
85	532 17 99-53	Perno 7/16-20 x 3.75 Gr. 5
87	532 17 18-77	Perno 5/16-18 unc x 3/4
90	817 00 06-16	Tornillo 3/8-16 x 1
91	532 18 74-95	Buje
116	539 13 26-24	Perilla
117	532 42 08-28	Abastecza de combustible Válvula

NOTA: Las dimensiones de todos los componentes están expresadas en pulgadas americanas. 1 pulgada = 25,4 mm

Para el servicio de motor y repuestos, llame el número de llamada gratuita para su fabricante de motor listó abajo:
Briggs & Stratton 1-800-233-3723

Información de Clasificación de Potencia del Motor

La clasificación de potencia para un modelo de motor a gas en particular se designa de acuerdo al código J1940 de SAE (Sociedad de Ingenieros Automotrices) (Procedimiento de Clasificación de Potencia & Torque del Motor Pequeño), y la clasificación de desempeño ha sido obtenida y corregida de acuerdo con el código J1995 de SAE (Revisión 2002-05). Los valores de torque se obtienen a 3060 RPM; los valores de potencia se obtienen a 3600 RPM. La potencia bruta actual del motor será inferior y está afectada, entre otras cosas, por las condiciones ambientales operativas y la variabilidad de motor a motor. Dado ambos un amplio conjunto de productos en los cuales son puestos nuestros motores, y la variedad de emisiones ambientales aplicables al operar el equipo, el motor a gas no desarrollará la potencia nominal cuando sea usado en una parte del equipo acoplado (potencia real "en el-sitio" o potencia neta). Esta diferencia se debe a una variedad de factores que incluyen, pero que no están limitados a, accesorios (filtro de aire, sistema de escape, sistema de carga, sistema de enfriamiento, carburador, bomba de combustible, etc.) limitaciones de la aplicación, condiciones ambientales de operación (temperatura, humedad, altitud), y la variabilidad de motor a motor. Debido a las limitaciones, Briggs & Stratton puede sustituir este motor con clasificación de potencia más alta por esta serie de motor.

TRACTOR -- MODELO NO. GTH27V48LS (96043011702), PRODUCT NO. 960 43 01-17
ENSAMBLE DE LA DIRECCIÓN

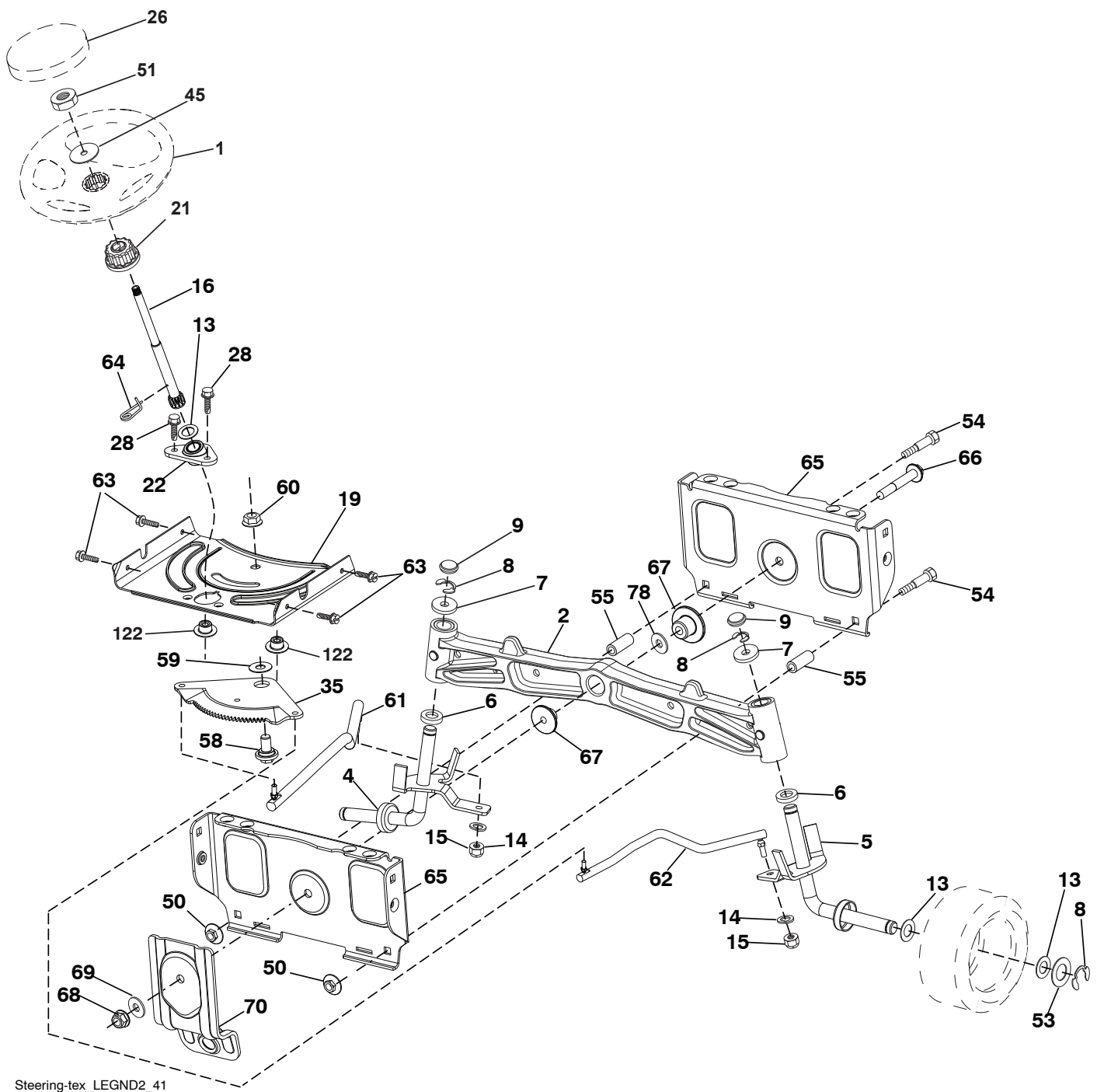

Steering-tex_LEGND2_41

**TRACTOR - - MODELO NO. GTH27V48LS (96043011702), PRODUCT NO. 960 43 01-17
ENSAMBLE DE LA DIRECCIÓN**

CÓDIGO PIEZA		DESCRIPCIÓN
No.	No.	
1	532 43 97-40	Volante de dirección
2	532 19 59-68	Ensamble del eje delantero
4	532 40 30-89	Ensamble del husillo izquierdo
5	532 40 30-90	Ensamble del husillo derecho
6	532 12 49-31	Pista del rodamiento para reforzar el impulso
7	532 12 17-48	Arandela 25/32 x 1-5/8 x 16 Ga.
8	812 00 00-29	Abrazadera del aro No. T5304-75
9	532 12 12-32	Tapa del husillo
13	532 12 17-49	Arandela 25/32 x 1-1/4 x 16 Ga.
14	810 04 06-00	Arandela 3/8
15	873 54 06-00	Tuerca 3/8-24 unf
16	532 40 82-19	Eje de dirección
19	532 19 47-29	Placa de dirección
21	532 18 67-37	Adaptador del volante de dirección
22	532 42 05-37	Soporte
26	532 43 97-43	Inserto del volante de dirección
28	817 00 06-12	Tornillo 3/8-16 x 3/4
35	532 19 47-32	Engranaje del sector de la placa
45	819 18 38-12	Arandela 9/16 x 2-3/8 x 12 Ga.
50	873 90 06-00	Tuerca 3/8-16 unc
51	873 94 08-00	Tuerca 1/2-20 unf
53	532 18 89-67	Arandela .793 x 1.637 x .060
54	874 76 06-36	Perno 3/8-16 unc x 2-1/4
55	532 41 47-36	Espaciador
58	532 19 47-47	Perno
59	532 19 47-48	Arandela
60	873 97 10-00	Tuerca 5/8-11
61	532 19 47-40	Barra de acoplamiento izquierda
62	532 19 47-41	Barra de acoplamiento derecha
63	817 00 05-12	Tornillo 5/16-18 x 3/4
64	532 19 98-49	Abrazadera de retención del resorte de la dirección
65	532 19 47-34	Soporte delantero del eje
66	871 02 07-48	Perno 7/16-14 x 3
67	532 19 47-37	Buje
68	873 90 07-00	Tuerca 7/16-14 Gr. 5
69	532 19 91-62	Arandela 1.5 x .505 x .118
70	532 19 61-97	Soporte
78	532 05 70-79	Arandela
122	532 44 49-62	Tapa

NOTA: Las dimensiones de todos los componentes están expresadas en pulgadas americanas. 1 pulgada = 25,4 mm

TRACTOR - - MODELO NO. GTH27V48LS (96043011702), PRODUCT NO. 960 43 01-17
PLATAFORMA DE LA CORTADORA DE CÉSPED

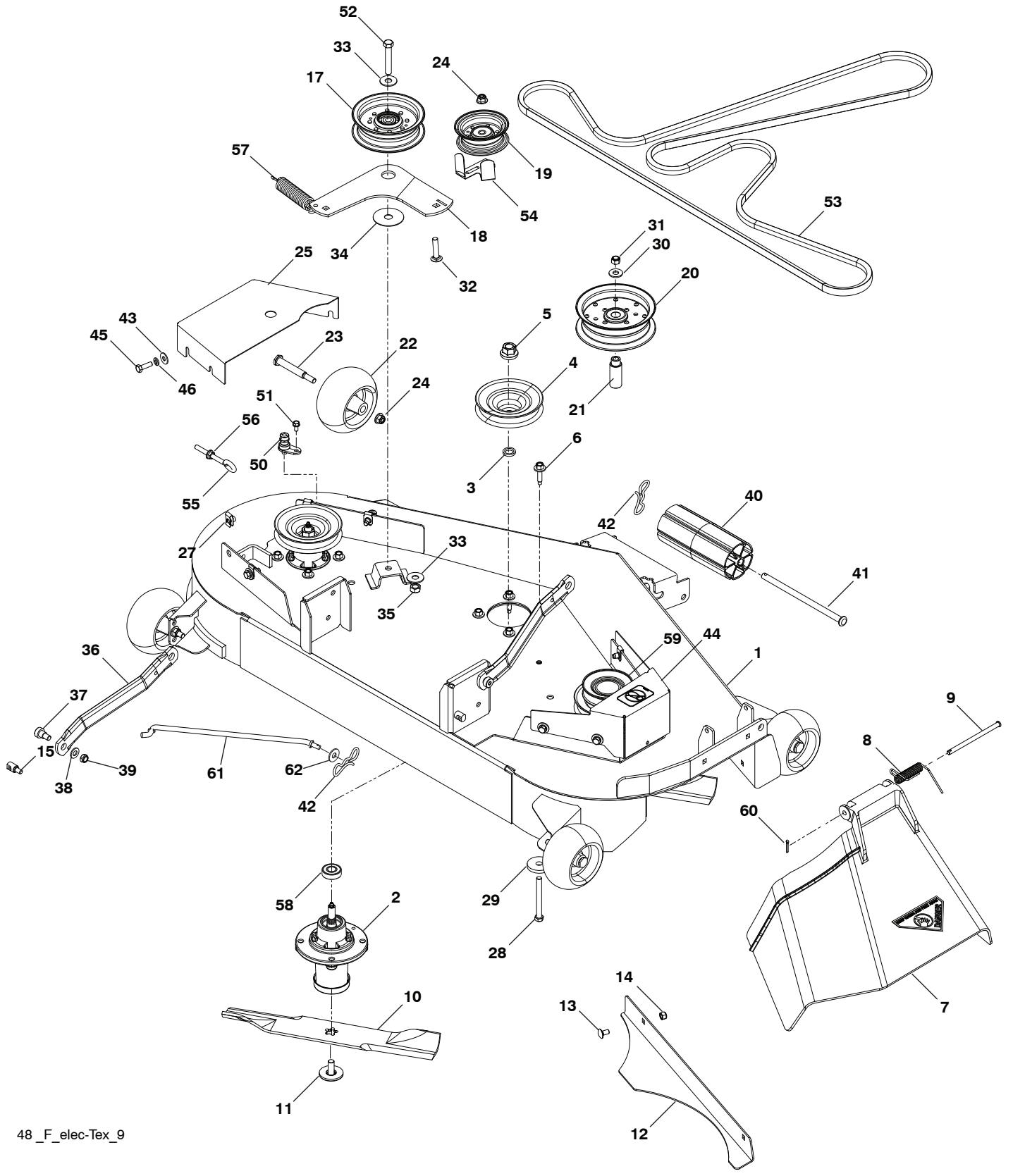

48_F_elec-TEX_9

**TRACTOR - - MODELO NO. GTH27V48LS (96043011702), PRODUCT NO. 960 43 01-17
PLATAFORMA DE LA CORTADORA DE CÉSPED**

CÓDIGO PIEZA			CÓDIGO PIEZA		
No.	No.	DESCRIPCIÓN	No.	No.	DESCRIPCIÓN
1	594 73 07-01	Kit de cubierta SVC	36	532 19 51-85	Brazo
2	539 11 21-70	Carcasa de la cortadora de césped	37	539 11 36-21	Sb 3/8-16 x 3/8 Skt Hd
3	532 18 76-90	Arandela	38	819 13 13-16	Arandela 13/32 x 13/16 x 16 Ga.
4	532 17 43-75	Polea	39	539 20 02-82	Tuerca, 3/8-16
5	532 40 02-34	Tuerca 9/16	40	532 17 60-66	Rodillo delantero
6	532 17 39-84	Tornillo	41	532 17 91-27	Soporte, rodillo delantero
7	539 11 07-32	Descargue tobogán 48"	42	532 19 42-08	Pasador de chaveta de 5/16 con bloqueo en forma de mariposa
8	539 11 07-35	Resorte de torsión	43	819 12 14-14	Arandela, 3/8 x 7/8 x 14 Ga.
9	539 11 07-36	Pasador de chaveta 5/16 x 5.19	44	575 96 72-02	Protector LD
10	539 11 34-25	Cuchilla de la cortadora de césped 16-1/4"	45	874 78 05-16	Hcs 5/16-18 x 1
11	532 19 30-03	Perno/ Arandela 7/16-20	46	810 03 05-00	Arandela 5/16
12	539 11 34-26	Plato de confinamiento	50	532 41 55-98	Puerto De Lavado De La Cubierta
13	872 11 05-05	Perno 5/16-18 x 5/8	51	817 49 04-08	Perno 1/4-20 x 1/2
14	873 80 05-00	Tuerca 5/16-18	52	874 78 07-40	Perno 7/16-14 x 2-1/2
15	532 19 51-61	Sujetador del travesaño	53	574 84 56-02	Cinturón
17	532 19 61-04	Polea	54	532 14 10-43	Protector
18	574 82 71-02	Brazo	55	539 11 55-74	Perno 5/16 x 3-1/2
19	532 17 79-68	Polea loca	56	873 90 05-00	Tuerca 5/16-18
20	539 13 27-28	Polea loca	57	539 10 68-50	Resorte
21	575 22 45-01	Buje	58	532 11 04-85	Rodamiento de bolas
22	532 13 39-57	Calibrador de la rueda	59	575 35 29-01	Polea
23	532 19 34-06	Perno	60	532 16 94-84	Abrazadera de retención
24	521 99 65-01	Tuerca 3/8-16	61	532 40 03-37	Barra
25	575 22 47-02	Protector LI	62	819 13 13-12	Arandela 13/32 x 13/16 x 12 Ga.
27	539 10 47-63	Retención 5/16c U Type	--	594 73 07-01	Kit de cubierta SVC
28	539 10 82-71	Hcs 3/8-16 x 3-1/2 Gr 5			
29	539 10 65-04	Arandela			
30	819 14 16-14	Arandela 3/8			
31	819 14 16-14	Tuerca 3/8-16			
32	539 99 09-23	Perno 3/8-16 x 1-3/4 Gr 5			
33	539 10 48-64	Arandela, 7/16			
34	532 17 85-15	Arandela			
35	873 90 07-00	Tuerca 7/16-14			

NOTA: Las dimensiones de todos los componentes están expresadas en pulgadas americanas. 1 pulgada = 25,4 mm

TRACTOR -- MODELO NO. GTH27V48LS (96043011702), PRODUCT NO. 960 43 01-17
ELEVACIÓN DE LA CORTADORA DE CÉSPED

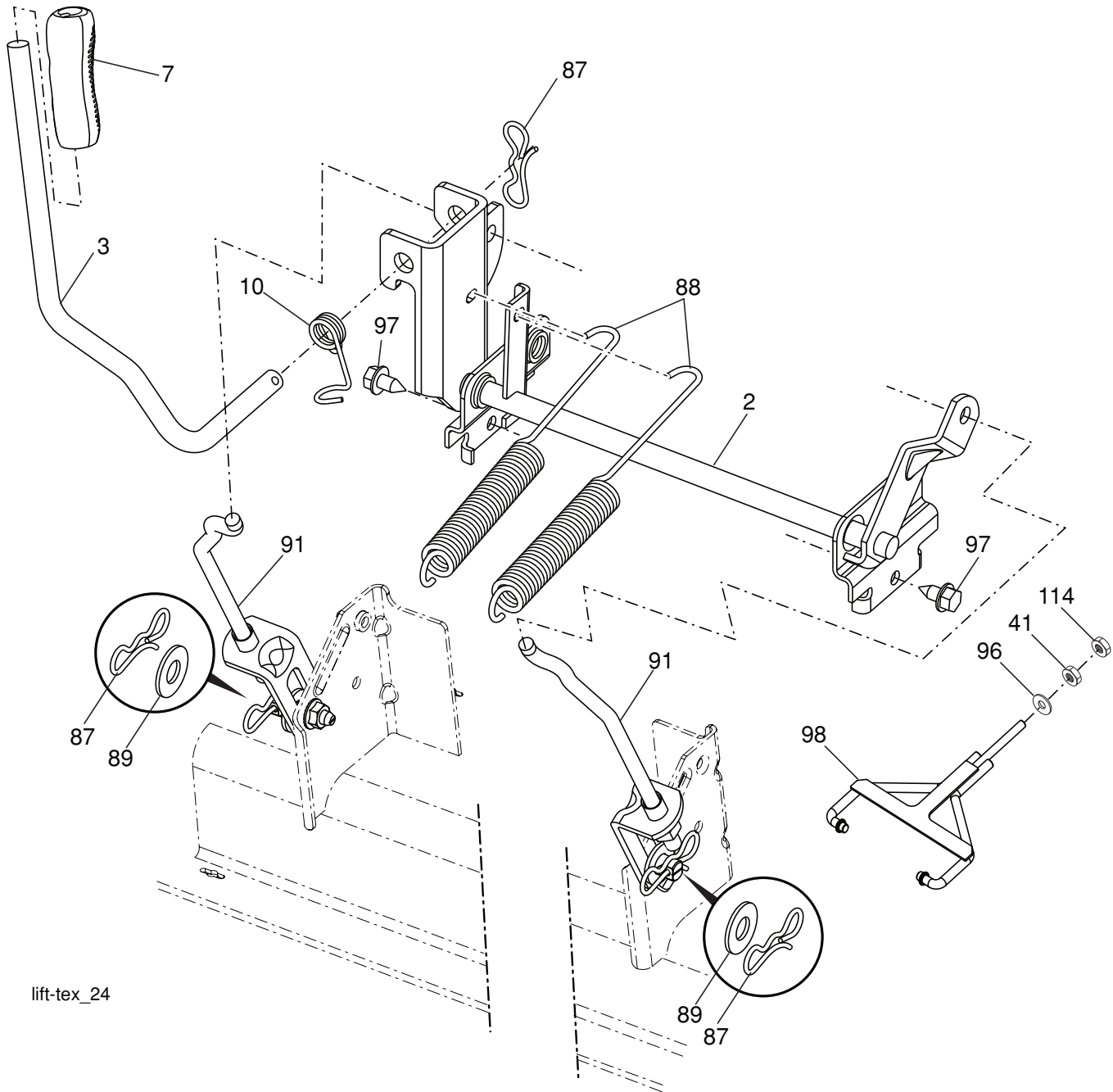

lift-tex_24

CÓDIGO PIEZA

No.	No.	DESCRIPCIÓN
2	532 42 20-27	Ensamble del eje de la elevación
3	532 19 52-30	Ensamble de la palanca de elevación derecha
7	580 96 23-01	Mango de la palanca
10	532 19 63-14	Resorte de torsión
41	532 17 59-94	Tuerca
87	532 19 42-09	Pasador de chaveta de 7/16 con bloqueo en forma de mariposa
88	532 19 53-04	Resorte de ayuda de la elevación
89	819 19 19-12	Arandela de zinc transparente

CÓDIGO PIEZA

No.	No.	DESCRIPCIÓN
91	532 40 34-07	Soporte
96	532 19 52-63	Buje
97	817 00 06-12	Tornillo 3/8-16 x .75
98	574 82 25-01	Acoplamiento frontal de la elevación de la cortadora de césped
114	873 36 07-00	Tuerca 7/16-20

NOTA: Las dimensiones de todos los componentes están expresadas en pulgadas americanas. 1 pulgada = 25,4 mm

**TRACTOR - - MODELO NO. GTH27V48LS (96043011702), PRODUCT NO. 960 43 01-17
ENSAMBLE DEL ASIENTO**

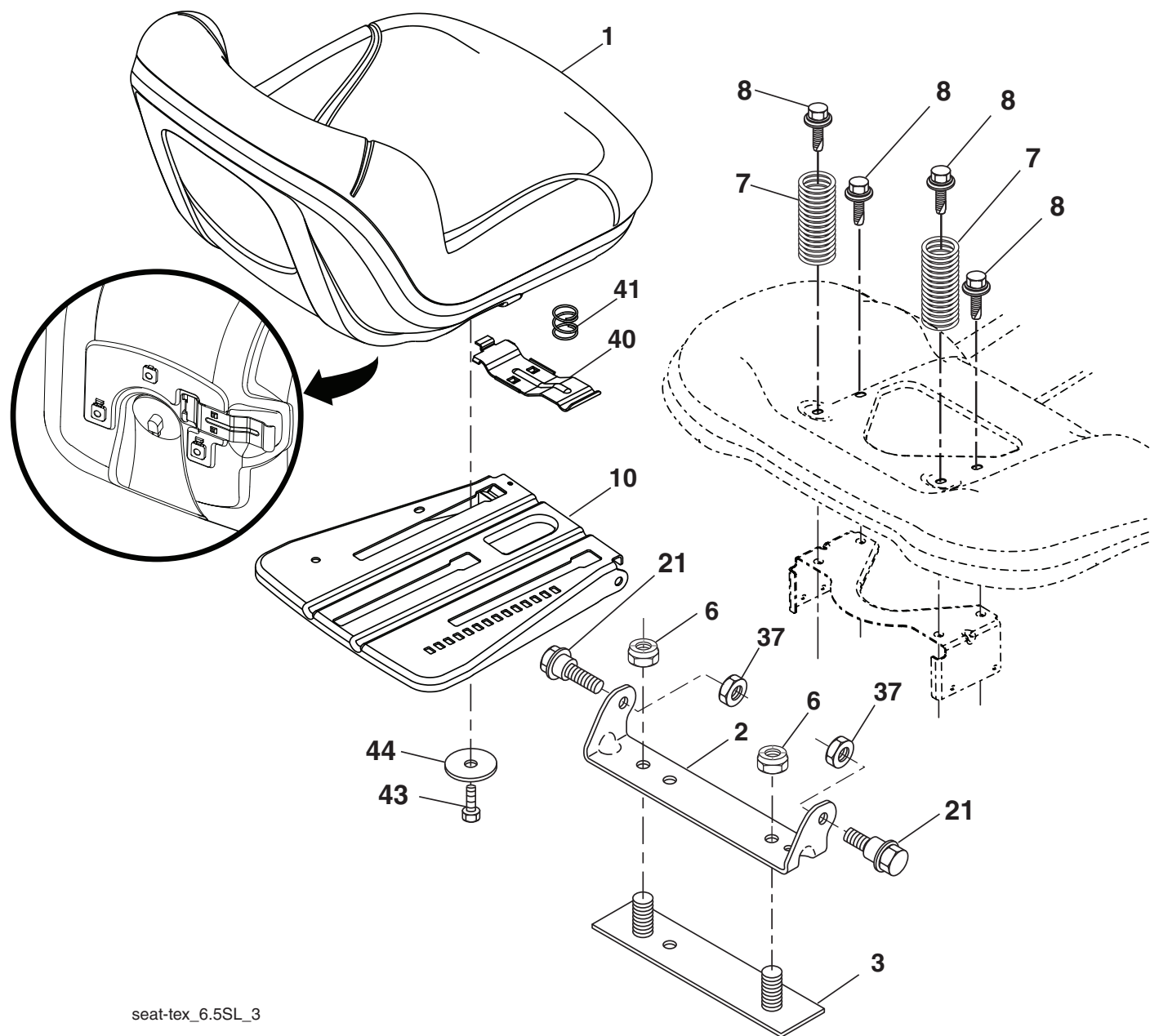

seat-tex_6.5SL_3

CÓDIGO No.	PIEZA No.	DESCRIPCIÓN
1	532 44 32-63	Asiento
2	532 18 01-66	Soporte pivotante del guardabarros
3	532 14 06-75	Conector del ensamble del guardabarros
6	873 80 06-00	Tuerca de presión c/aislamiento de 3/8-16 UNC
7	532 12 41-81	Resorte del asiento
8	532 17 18-77	Perno 5/16-18 unc x 3/4
10	532 19 69-77	Bandeja del asiento
21	532 17 18-52	Perno 5/16-18

CÓDIGO No.	PIEZA No.	DESCRIPCIÓN
37	873 80 05-00	Tuerca de presión de 5/16-18 UNC
40	532 43 98-71	Manija para deslizar el asiento
41	532 19 82-00	Resorte para trabar el asiento
43	874 76 06-12	Perno de cabeza hexagonal con aleta de 3/8-16 UNC x 3/4
44	819 13 38-12	Arandela de 13/32 x 2-3/8 calibre 12

NOTA: Las dimensiones de todos los componentes están expresadas en pulgadas americanas. 1 pulgada = 25,4 mm

**TRACTOR - - MODELO NO. GTH27V48LS (96043011702), PRODUCT NO. 960 43 01-17
CALCOMANÍAS**

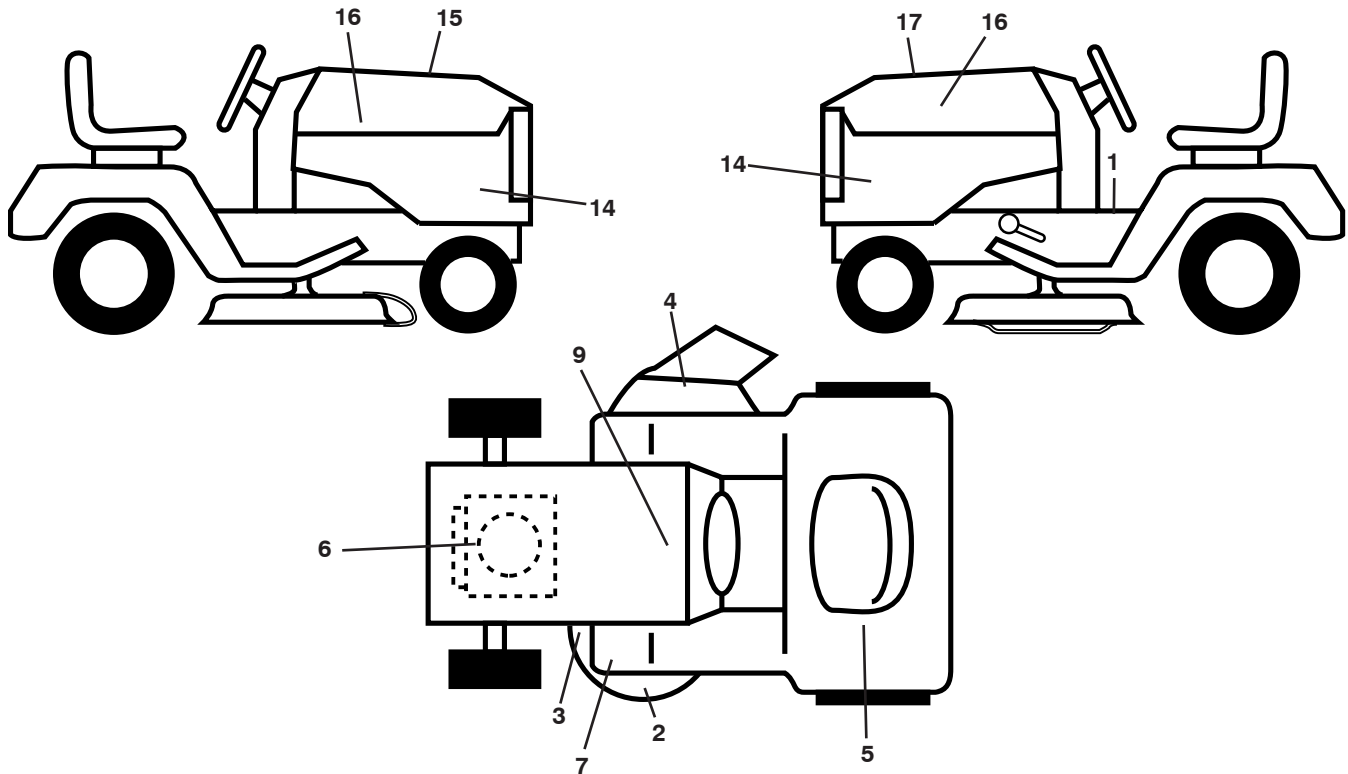

CÓDIGO PIEZA

No.	No.	DESCRIPCIÓN
1	532 41 16-57	Calcomanía para el guardabarros del operador
2	581 72 43-01	Calcomanía de ninguñ n paso
3	532 19 87-85	Calcomanía del diagrama de la cortadora de césped
4	539 11 32-24	Calcomanía para advertencia
5	532 42 62-09	Calcomanía para advertencia
6	532 43 29-18	Calcomanía para el motor
7	532 41 86-00	Calcomanía del pedal
9	532 14 50-05	Calcomanía de Peligro/Punto de interconexión

CÓDIGO PIEZA

No.	No.	DESCRIPCIÓN
14	532 43 87-17	Calcomanía para el panel lateral
15	532 42 38-29	Calcomanía del cliente
16	581 62 73-01	Calcomanía para la capota
17	532 43 84-75	Calcomanía de reemplazo
--	532 16 69-60	Calcomanía para la desviación
--	532 43 98-82	Forro del apoyo para los pies (LI)
--	532 43 98-81	Forro del apoyo para los pies (LD)
--	532 44 51-46	Manual de Dueños (Ing/Esp)
--	532 44 53-38	Manual de Repuestos (Ing/Esp)

RUEDAS Y NEUMÁTICOS

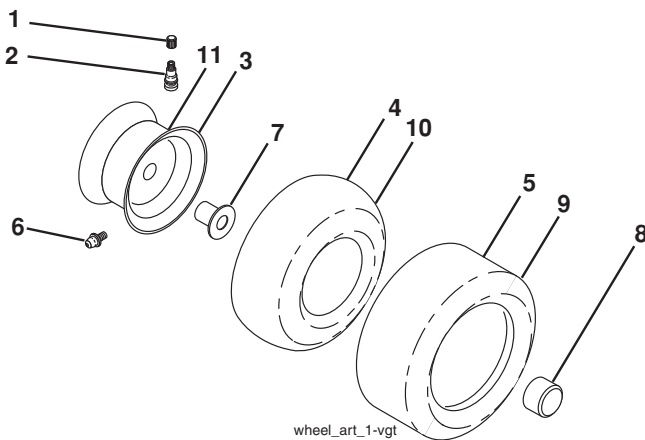

CÓDIGO PIEZA

No.	No.	DESCRIPCIÓN
1	532 05 91-92	Tapa de la válvula del neumático
2	532 06 51-39	Vástago de la válvula
3	532 18 18-39	Ensamble de las llantas delanteras
4	532 00 81-34	Cámara delantera (Mantenimiento sólo)
5	532 16 10-24	Neumático delantero
6	532 12 49-57	Accesorio para engrasar (solo para la rueda delantera)
7	532 12 49-59	Rodamiento de la brida (solo para la rueda delantera)
8	532 17 50-39	Tapa del eje
9	532 17 04-53	Neumático trasero
10	532 00 71-54	Cámaratrasera (Mantenimientosólo)
11	532 14 45-10	Ensamble trasero de la llanta
--	532 14 43-34	Sellador para neumáticos (tubo de 10 onzas [283 gr])

NOTA: Las dimensiones de todos los componentes están expresadas en pulgadas americanas. 1 pulgada = 25,4 mm

NOTES/AVISO



www.husqvarna.com