

**Repair Parts Manual**  
**Manual De Repuestos**  
**TS 354X / 96043024301**

Please read the operator's manual carefully and make sure you understand the instructions before using the machine.

Por favor lea cuidadosamente y comprenda estas instrucciones antes de usar esta maquina.



**English/Spanish**

**114 06 08-49 Rev. 3**



# HOW TO USE THIS MANUAL

This manual is designed to provide the customer with a means to identify the parts on his/her tractor when ordering repair parts. The illustrations may or may not represent the actual assemblies; therefore, it is not recommended to use this manual as a guide to assemble or disassemble the tractor. Some hardware and parts are drawn larger in order to more readily identify them.

Each tractor has its own model number. The model number for your tractor can be found on the fender under the seat.

## Support / Help

If you require assistance or have questions concerning the application, operation, maintenance or parts for your product:

- Visit our website: [www.husqvarna.com](http://www.husqvarna.com)
- Call Us Toll Free: 1-800-487-5951

When ordering parts, always give the following information:

- Product - "TRACTOR"
- MODEL NUMBER - "TS 354X"(96043024301)"
- Part Number
- Part Description

# TABLE OF CONTENTS

DECALS.....	3
SCHEMATIC .....	4-5
ELECTRICAL.....	6-7
CHASSIS.....	8-9
DRIVE.....	10-11
ENGINE.....	12-13
STEERING .....	14-15
MOWER DECK .....	16-17
MOWER LIFT.....	18
SEAT .....	19
ESPAÑOL .....	20

**TRACTOR - MODEL NO. TS 354X (96043024301), PRODUCT NO. 960 43 02 43  
DECALS**

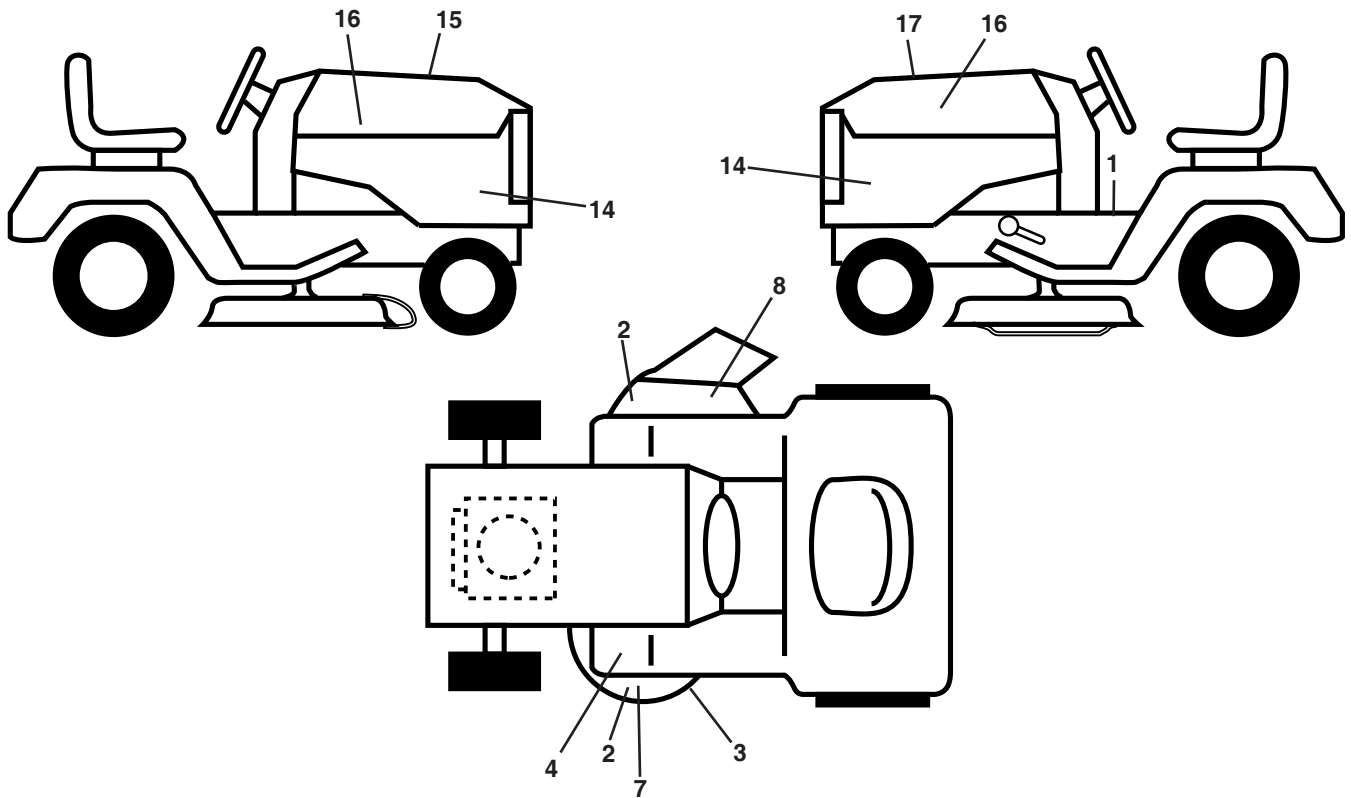

KEY NO.	PART NO.	DESCRIPTION
1	581 57 89-01	Decal, Warning
2	589 35 79-01	Decal, No Step
3	592 89 83-01	Decal, Deck Warn
4	591 16 47-01	Decal, Deck Belt Routing
7	593 80 88-01	Decal, Deck 54 CC
8	586 97 88-01	Decal, Deflect. Warning
14	591 44 86-01	Decal, Panel Side
15	532 42 38-29	Decal, Cust. Resp.
16	581 62 73-01	Decal, Hood Logo
17	593 09 12-01	Decal, Replacement
--	581 57 90-01	Decal, FNDR Warn.

KEY NO.	PART NO.	DESCRIPTION
--	581 72 48-01	Decal, Bypass
--	532 43 98-82	Pad, Footrest, LH
--	532 43 98-81	Pad, Footrest, RH
--	114 06 07-49	Manual, Operator's (English/Spanish)
--	114 06 09-33	Manual, Operator's (French)
--	114 06 08-49	Manual, Part's (English/Spanish)
--	114 06 10-33	Manual, Part's (French)
--	587 71 00-26	Manual, QSG Husq (English/Spanish)
--	587 71 01-26	Manual, QSG Husq (English/French)

**WHEELS AND TIRES**

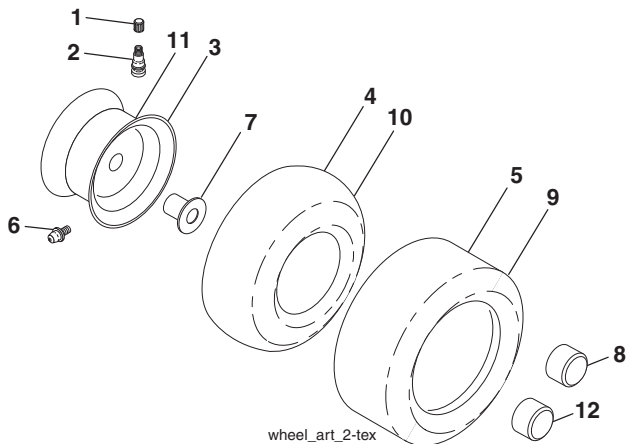

KEY NO.	PART NO.	DESCRIPTION
1	532 05 91-92	Cap, Valve, Tire
2	532 06 51-39	Stem, Valve
3	532 18 18-39	Rim Assembly, Front
4	532 00 81-34	Tube, Front (Service Item Only)
5	593 14 51-01	Tire, Front 16 x 6.5-8
6	532 12 49-57	Fitting, Grease (Front Wheel Only)
7	532 12 49-59	Bearing, Flange (Front Wheel Only)
8	532 17 50-39	Cap, Axle, Front
9	593 14 52-01	Tire, Rear 23 x 10.5-12
10	532 00 71-54	Tube, Rear (Service Item Only)
11	593 14 48-01	Rim Assembly, Rear
12	501 50 31-01	Cap, Hub, GT, PM, Black, Rear
--	532 14 43-34	Sealant, Tire (10 oz. Tube)

**NOTE:** All component dimensions given in U.S. inches  
1 inch = 25.4 mm



# TRACTOR - MODEL NO. TS 354X (96043024301), PRODUCT NO. 960 43 02 43 SCHEMATIC

SCH35b

## MOWER CONTROL MODULE - CHASSIS HARNESS



-DO NOT OPEN!  
-PERMANENT DAMAGE CAN RESULT  
IF PROPER DIAGNOSTIC PROCEDURES  
ARE NOT FOLLOWED.  
-CONTACT YOUR DEALER OR AUTHORIZED  
SERVICE CENTER FOR REPAIR.



SENSITIVE ELECTRONIC  
COMPONENTS INSIDE!



(COLOR:  
CONNECTOR NUMBER - CAVITY NUMBER)

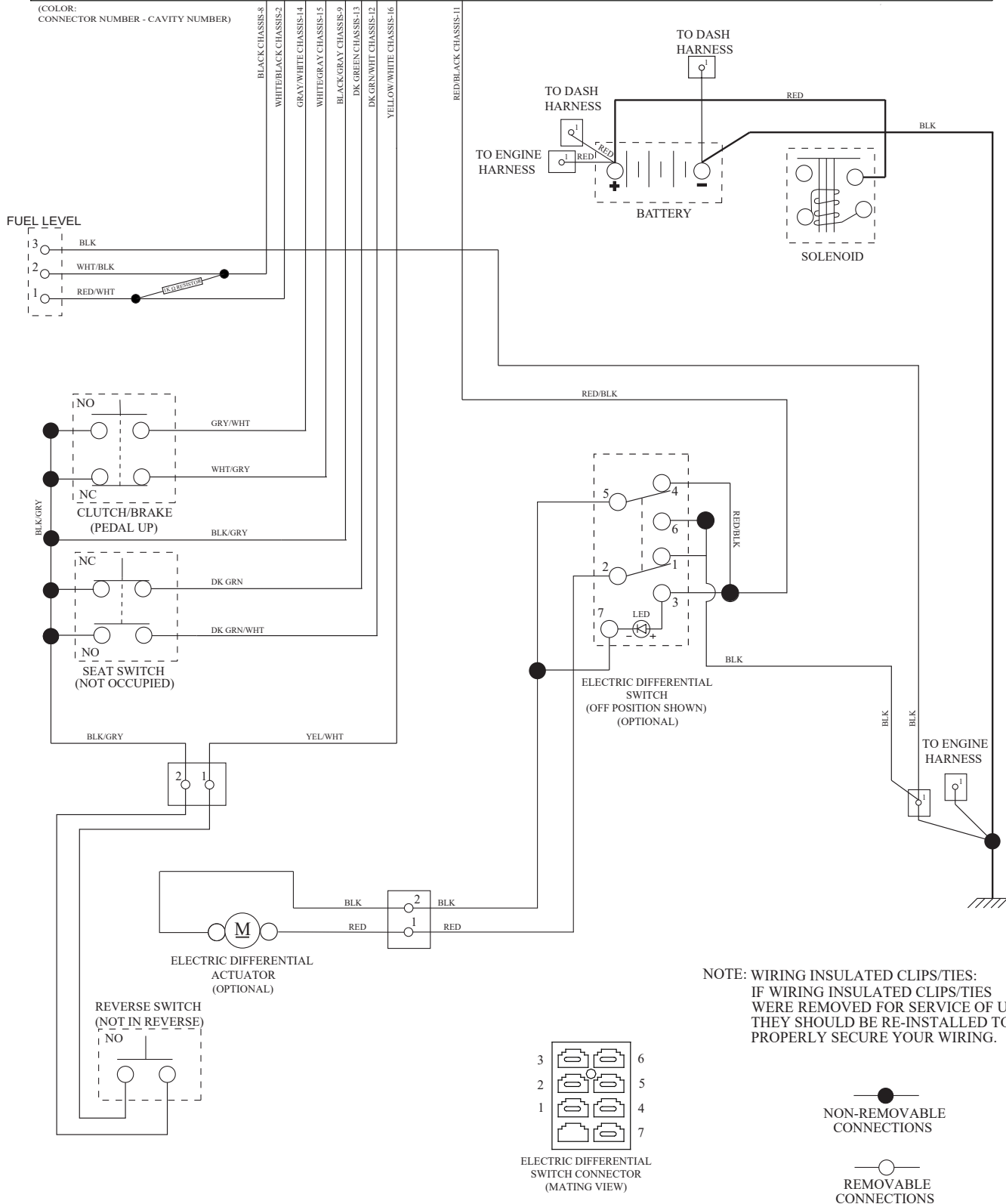

**TRACTOR - MODEL NO. TS 354X (96043024301), PRODUCT NO. 960 43 02 43  
ELECTRICAL**

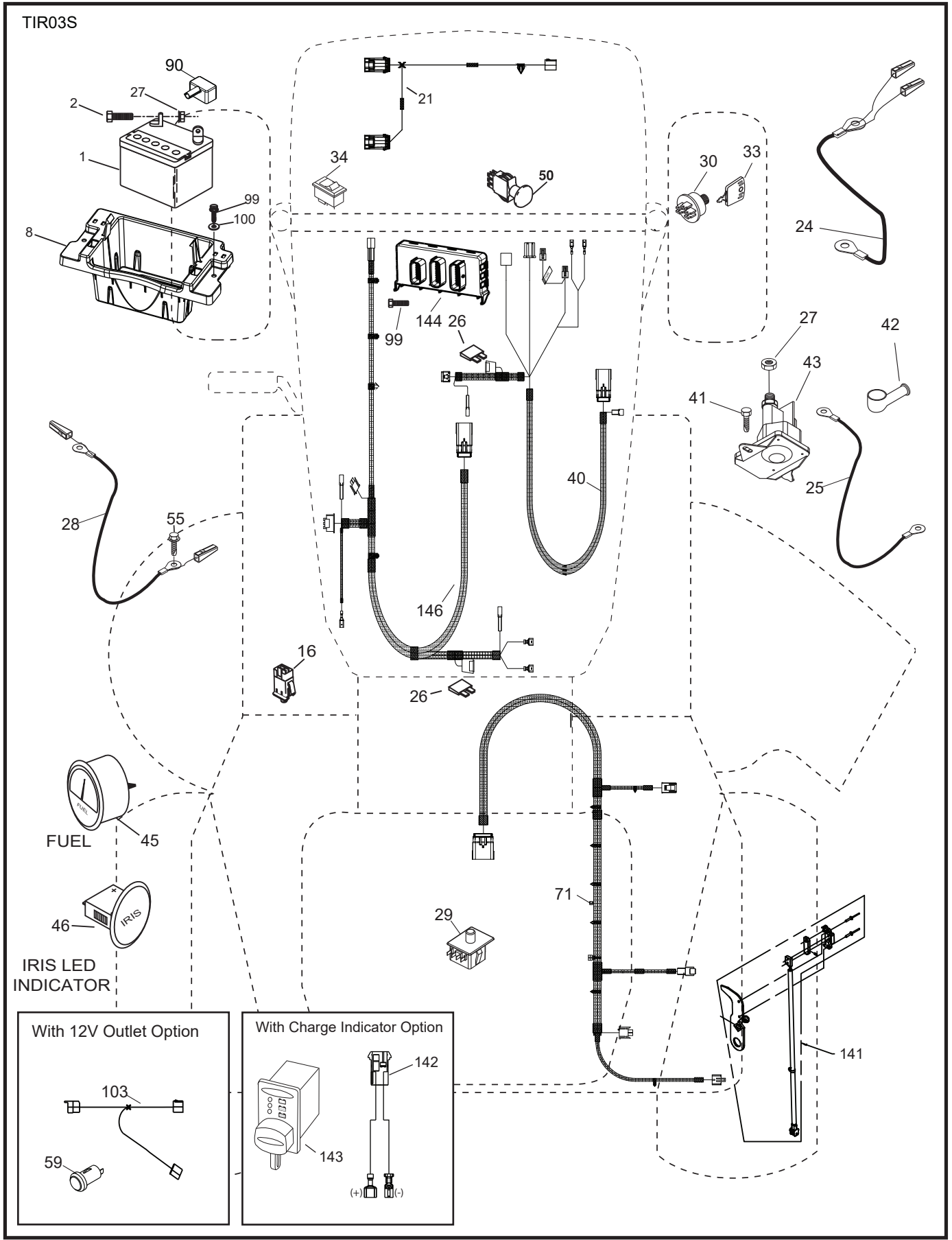

**TRACTOR - MODEL NO. TS 354X (96043024301), PRODUCT NO. 960 43 02 43  
ELECTRICAL**

<b>KEY NO.</b>	<b>PART NO.</b>	<b>DESCRIPTION</b>
1	532 16 34-65	Battery
2	874 76 04-12	Bolt Hex Hd 1/4-20 unc x 3/4
8	587 20 51-01	Battery Box
16	532 17 61-38	Switch Interlock
21	585 43 64-01	Harness Light
24	590 22 38-01	Cable Iris FR Batt
25	585 55 55-01	Cable Starter
26	532 17 51-58	Fuse
27	873 51 04-00	Nut Keps Hex 1/4-20 unc
28	590 22 37-01	Cable Ground
29	587 64 84-01	Switch Seat
30	532 19 33-50	Switch Ign
33	532 41 19-35	Key/Chain
34	532 11 07-12	Switch Light/Reset
40	590 19 32-01	Harness Ign. Dash Iris
41	817 72 04-08	Screw 1/4-20 unc x 1/2
42	532 13 15-63	Cover Terminal Red
43	582 04 28-01	Solenoid
45	590 64 59-01	Guage Fuel Lever Round 2"
46	594 72 15-01	Gauge 6 LED Iris
50	582 10 76-01	Switch PTO
55	817 06 05-12	Screw Thdrol 5/16-18 x 3/4
59	532 40 03-03	Outlet 12-Volt
71	590 19 33-01	Harness Ign Chassis Iris
90	532 43 53-95	Cover Terminal Battery
99	817 67 04-12	Screw Hexwsh Thdrol 1/4-20 x 3/4
100	819 09 14-16	Washer 9/32 x 7/8 x 16 Ga.
141	532 42 12-25	Kit G700/G730 ROS
144	590 56 80-01	Control Unit Ride On IRIS Base
146	590 19 34-01	Harness Engine

**NOTE:** All component dimensions given in U.S. inches  
1 inch = 25.4 mm





**TRACTOR - MODEL NO. TS 354X (96043024301), PRODUCT NO. 960 43 02 43 CHASSIS**

KEY NO.	PART NO.	DESCRIPTION
2	580 43 44-01	Drawbar
3	532 44 44-81	Applique Sub Asm.
5	590 74 00-17	Dash
14	532 44 11-77	Hood
15	585 42 03-01	Lens LH
18	587 52 34-01	Grille
25	585 42 02-01	Lens RH
36	817 06 05-12	Screw 5/16-18 x 3/4
37	590 53 47-02	Fender
58	532 19 43-14	Bracket Fender
68	539 99 08-58	Screw 5/16-18 x 1/2
125	581 68 48-01	Clip Fuel Line
130	532 41 63-58	Screw #10 x 0.750 BOS Thread
137	532 40 75-90	Bumper Dash
146	581 85 79-01	Bolt
150	532 43 97-74	Duct Air
151	532 43 66-70	Bracket Pivot Hood
152	532 43 98-70	Shield Browning/Debris
162	532 14 24-32	Screw Hex Wsh Hi-Lo 1/4 x 1/2
165	532 19 43-30	Bracket Support Tank
175	590 60 77-02	Crossmember
176	532 40 07-76	Screw 10-24 x 5/8 Wshd Qdrc
177	532 19 52-28	Bushing Steering
180	593 34 63-01	Chassis
182	532 40 68-59	Dash Lower
183	874 52 05-20	Bolt 5/16-18 x 1-1/4
189	817 00 05-12	Screw 5/16-18 x 3/4
191	586 18 28-01	Insert Reflective RH
194	873 90 05-00	Nut Lock Hex Flange 5/16-18
196	532 43 96-74	Console Asm. Deck Lift

KEY NO.	PART NO.	DESCRIPTION
199	532 19 82-59	Plate Deck Lift
202	532 43 97-28	Vent Side Hood RH
203	532 43 97-27	Vent Side Hood LH
204	532 43 57-14	Vent Asm Hood Top
205	532 43 97-30	Skirt Hood Side RH
206	532 43 97-29	Skirt Hood Side LH
207	585 42 00-02	Bezel RH
208	585 42 01-02	Bezel LH
214	532 19 91-45	Clip Retainer
217	532 40 91-67	Rod Pivot
221	532 19 89-09	Reflector LH
228	532 19 51-61	Stud Fastener
235	532 40 61-29	Spacer Fender
236	873 93 05-00	Nut Center Lock 5/16-18 unc
281	817 00 06-16	Screw 3/8-16 x 1
296	585 42 05-01	LED Light LH
297	586 18 29-01	Insert Reflective LH
299	585 42 04-01	LED Light RH
306	873 90 06-00	Nut Lock
335	532 44 82-04	Cover RH
336	532 44 53-09	Cover LH
350	532 44 51-43	Clip X-mas Tree
375	586 90 82-01	Dash Clip-On Bumper
378	590 84 98-01	Bushing Flange Plastic
379	593 20 69-02	Chassis Plate Reinforcement
--	532 43 18-82	Kit Guard Brush

**NOTE:** All component dimensions given in U.S. inches  
1 inch = 25.4 mm

**TRACTOR - MODEL NO. TS 354X (96043024301), PRODUCT NO. 960 43 02 43  
DRIVE**

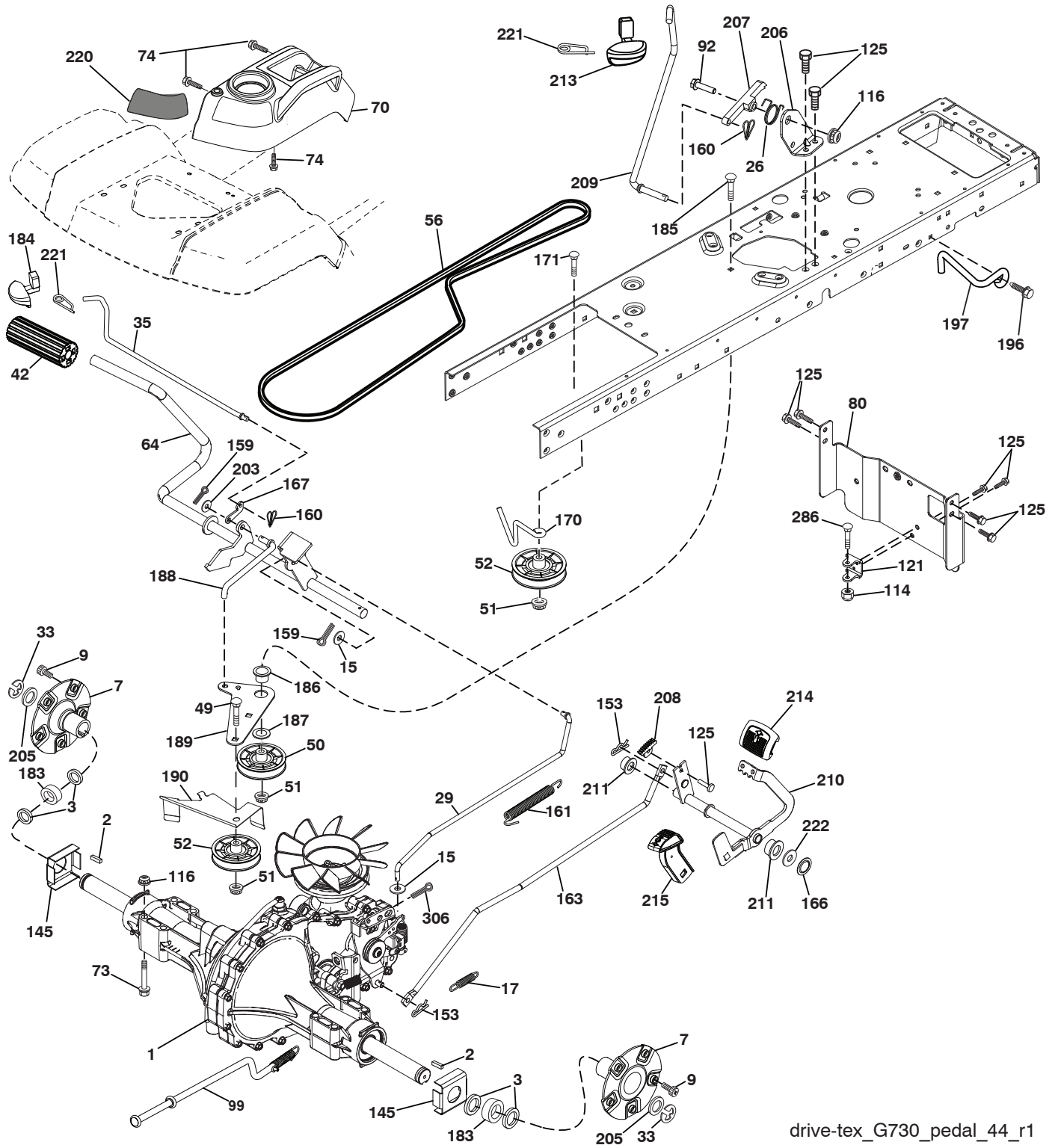

drive-tex\_G730\_pedal\_44\_r1

**TRACTOR - MODEL NO. TS 354X (96043024301), PRODUCT NO. 960 43 02 43  
DRIVE**

KEY NO.	PART NO.	DESCRIPTION
1	---	Transaxle, Hydro G7-BCBB-1XDC-1FCA (420331) (Order parts from transaxle manufacturer.)
2	539 91 27-57	Key .25 x 1.25
3	532 00 75-63	Washer Thrust Axle Hardened
7	586 93 54-02	Hub Asm. Wheel
9	532 14 00-80	Bolt Hub Wheel
15	819 13 13-16	Washer 13/32 x 13/16 x 16 Ga.
17	532 19 72-96	Spring, Brake
26	532 19 96-79	Spring Return Cruise
29	532 41 81-86	Rod, Brake
33	812 00 00-53	Ring E
35	590 60 59-02	Rod, Brake, Park
42	532 12 48-72	Cover, Foot Pedal
49	872 11 06-14	Bolt RDHD 3/8-16 unc x 1-3/4
50	532 19 43-27	Pulley Idler Flat
51	873 90 06-00	Lock Nut 3/8-16
52	532 19 43-26	Idler V-Groove Offset
56	532 14 02-94	V-Belt, Drive
64	532 19 78-65	Shaft Asm. Pedal Brake Control
70	532 43 96-61	Console Asm
73	874 49 05-48	Bolt Hex 5/16-18 x 3 Gr. 5
74	532 14 24-32	Screw 1/4 x 1/2
80	532 41 81-84	Strap Torque
92	874 76 05-20	Bolt 5/16-18 x 1/2
99	590 64 02-01	Spring Bypass
114	873 80 05-00	Nut Lock Hex W/Ins. 5/16-18 unc
116	873 90 05-00	Nut Lock Hex Flange 5/16-18
121	532 17 56-11	Bracket Strap Torque
125	817 00 05-12	Screw 5/16-18 x 3/4
145	532 16 31-68	Washer Axle Flange
153	532 12 47-88	Retainer Spring
159	876 02 04-12	Pin Cotter 1/8 x 3/4
160	532 16 94-84	Retainer Clip

KEY NO.	PART NO.	DESCRIPTION
161	532 10 57-09	Spring, Return, Clutch
163	532 41 81-85	Rod Pedal Control
166	532 42 91-64	Nut Push .625
167	532 40 52-57	Latch Brake Parking
170	532 19 43-22	Keeper V-Idler Center Span
171	872 11 06-16	Bolt 3/8-16 unc x 2
183	501 05 15-01	Spacer Split
184	587 65 37-01	Handle Parking Brake
185	872 11 06-22	Bolt RDHD 3/8-16 unc x 2-3/4
186	532 19 43-21	Spacer Retainer
187	819 13 32-10	Washer
188	582 21 70-01	Link Clutch Ground Drive Long
189	532 19 43-17	Bellcrank Ground Drive
190	532 19 43-18	Keeper Bellcrank Ground Drive
196	817 00 06-16	Screw 3/8-16 x 1
197	585 65 86-01	Bracket Clutch Anti-Rotation
203	819 11 11-16	Washer 11/32 x 11/16 x 16 Ga.
205	532 12 38-00	Washer 1-1/32 x 1-5/8 x 16 Ga.
206	532 44 85-96	Bracket Mount Latch Cruise
207	587 03 14-01	Latch Control Cruise
208	532 19 78-69	Gear Sector Control Cruise
209	590 52 78-02	Rod Control Cruise
210	532 19 78-60	Rocker Asm. Pedal Control
211	532 12 01-83	Bearing Nylon
213	532 40 31-19	Knob Control Cruise
214	532 42 12-63	Pedal Forward
215	586 60 65-02	Pedal Reverse
220	532 19 89-08	Reflector RH
221	532 40 31-87	Retainer Spring Clip Handle
222	879 21 20-10	Washer 21/32 x 1-1/4 x 10 Ga.
286	872 01 05-20	Bolt 5/16-18 x 2.50
306	876 02 04-16	Pin Cotter 1/8 x1

**NOTE:** All component dimensions given in U.S. inches  
1 inch = 25.4 mm

**TRACTOR - MODEL NO. TS 354X (96043024301), PRODUCT NO. 960 43 02 43  
ENGINE**

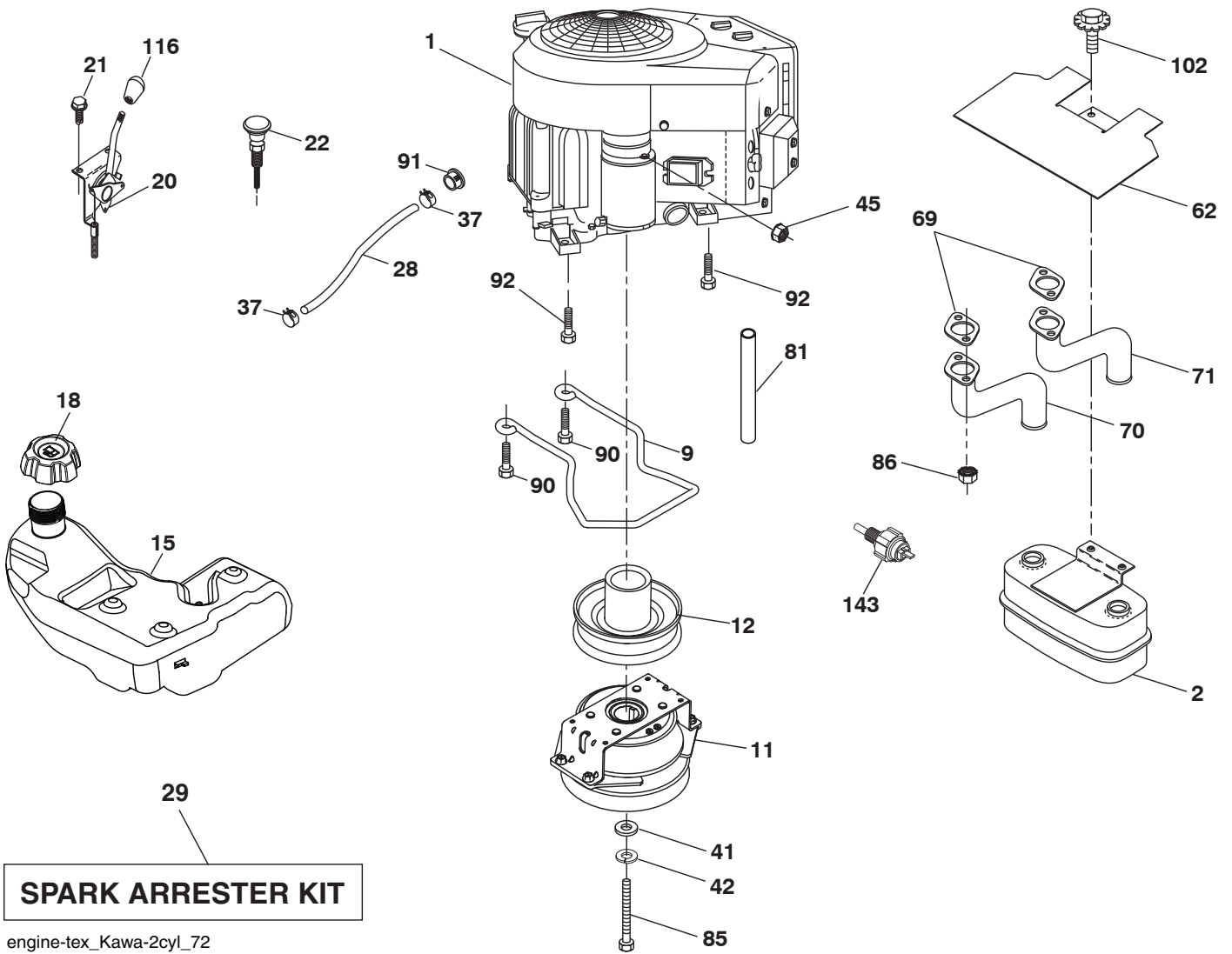

**TRACTOR - MODEL NO. TS 354X (96043024301), PRODUCT NO. 960 43 02 43  
ENGINE**

<b>KEY NO.</b>	<b>PART NO.</b>	<b>DESCRIPTION</b>
1	-- -- -- --	Engine KAWA Model No. FR730V-ES04 (445363)(Order parts from engine manufacturer.)
2	589 81 87-01	Muffler
9	501 83 26-02	Keeper Asm. Belt Engine
11	587 24 14-01	Clutch Electric
12	532 19 43-43	Pulley Engine
15	590 59 94-02	Tank Fuel
18	585 12 48-01	Cap Asm
20	532 42 43-41	Control Throttle
21	532 41 63-58	Screw #10 x 0.750 BOS Thread
22	532 18 95-41	Control Choke
28	532 40 11-35	Fuel Line
29	532 13 71-80	Spark Arrester Kit
37	532 12 34-87	Clamp Hose
41	532 12 61-97	Washer 1-1/2 OD x 15/32 ID x .250
42	539 99 02-47	Washer 7/16
45	873 51 04-00	Nut Keps Hex 1/4-20 unc
62	532 43 40-17	Shield Heat Muffler
69	532 17 81-51	Gasket
70	583 95 56-01	Tube Exhaust LH
71	583 95 57-01	Tube Exhaust RH
81	532 14 84-56	Oil Tube Drain
85	501 60 69-01	Bolt 7/16-20 x 3.0 x Gr. 5
86	532 18 43-62	Nut Hex M8-1.25
90	817 00 06-16	Screw 3/8-16 x 1
91	532 18 74-95	Bushing
92	817 12 06-16	Screw 3/8-16 x 1
102	817 00 05-12	Screw 5/16 x 3/4
116	539 13 26-24	Knob Soft Touch
143	590 04 44-01	Sensor Oil Pressure Switch

**NOTE:** All component dimensions given in U.S. inches  
1 inch = 25.4 mm

For engine service and replacement parts, call the toll free number for your engine manufacturer listed below:

Kawasaki                      1-949-460-5688

TRACTOR - MODEL NO. TS 354X (96043024301), PRODUCT NO. 960 43 02 43  
STEERING ASSEMBLY

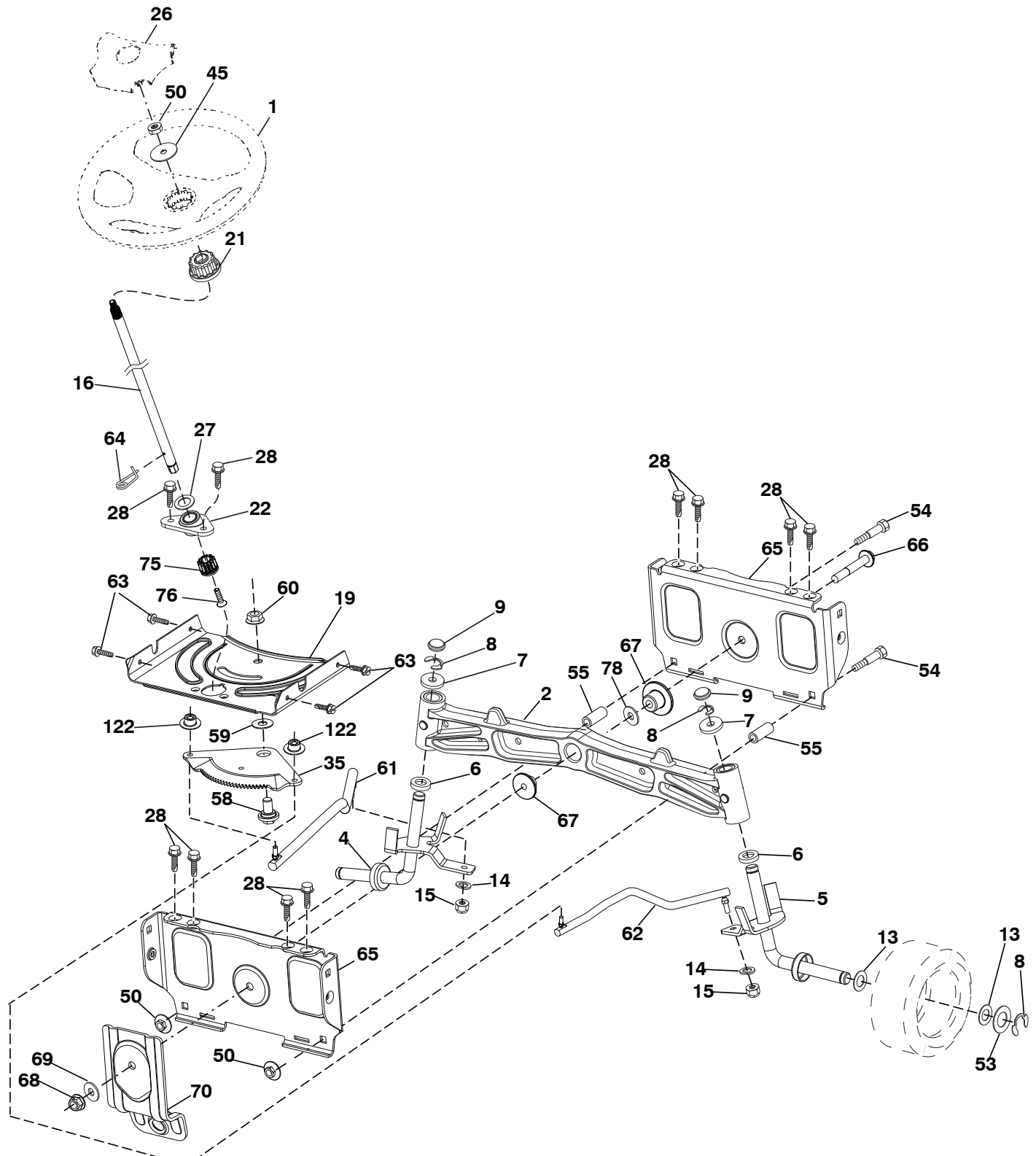

steering-tex\_HUSQSR\_70

**TRACTOR - MODEL NO. TS 354X (96043024301), PRODUCT NO. 960 43 02 43  
STEERING ASSEMBLY**

<b>KEY PART NO.</b>	<b>PART NO.</b>	<b>DESCRIPTION</b>
1	532 43 97-40	Wheel, Steering
2	532 19 59-68	Axle Asm., Front
4	532 40 30-89	Spindle Asm. LH
5	532 40 30-90	Spindle Asm. RH
6	532 12 49-31	Bearing, Race Thrust Harden
7	532 12 17-48	Washer 25/32 x 1-5/8 x 16 Ga.
8	812 00 00-29	Ring, Clip #T5304-75
9	532 12 12-32	Cap, Spindle
13	532 12 17-49	Washer 25/32 x 1-1/4 x 16 Ga.
14	539 99 01-18	Washer 3/8
15	873 54 06-00	Nut, Crown Lock 3/8-24 unf
16	587 01 60-02	Steering Shaft
19	532 19 47-29	Plate Steering
21	586 84 02-01	Adapter Wheel Steering
22	585 02 99-01	Bearing
26	532 43 97-43	Insert, Wheel Steering
27	819 21 16-16	Washer
28	817 00 06-12	Screw 3/8-16 x 3/4
35	532 19 47-32	Gear, Sector Plate
45	587 01 64-01	Washer 3/8 ID 2-3/8 OD 12 Ga. PLTD
50	873 90 06-00	Nut Lock Flg 3/8-16 unc
53	532 18 89-67	Washer Hardened .793 x 1.637 x .060
54	874 76 06-36	Bolt Hex 3/8-16 unc x 2-1/4
55	532 41 47-36	Bolt Hex 3/8-16 unc x 2-1/4
58	532 19 47-47	Bolt Shoulder Sector Pivot CFM
59	532 19 47-48	Washer Thrust Sector Steering
60	873 97 10-00	Nut Flange Lock 5/8-11
61	588 79 44-02	Draglink, LH
62	588 79 45-02	Draglink, RH
63	817 00 05-12	Screw 5/16-18 x 3/4
64	532 19 98-49	Retainer Clip Spring Steering
65	532 19 47-34	Brace Axle Front
66	871 02 07-48	Bolt Hex Fghd 7/16-14 x 3 Serr
67	532 19 47-37	Bushing PM Front Axle
68	873 90 07-00	Nut Lock Flange 7/16-14 Gr. 5
69	532 19 91-62	Washer 1.5 x .505 x .118
70	585 33 88-01	Bracket Deck Susp. Front
75	580 68 37-01	Pinion
76	580 68 36-01	Screw Head Sock
78	532 05 70-79	Washer Thrust
122	532 44 49-62	Cap Gear Sector

**NOTE:** All component dimensions given in U.S. inches  
1 inch = 25.4 mm





**TRACTOR - MODEL NO. TS 354X (96043024301), PRODUCT NO. 960 43 02 43  
MOWER DECK**

<b>KEY PART NO. NO.</b>	<b>DESCRIPTION</b>	<b>KEY PART NO. NO.</b>	<b>DESCRIPTION</b>
1	588 54 90-02 Deck Weldment Mower	51	574 16 96-01 Roller Guage
6	590 30 43-03 Cover Mandrel LH	52	532 19 73-79 Pulley Idler 4.50
7	590 30 42-03 Cover Mandrel RH	53	872 14 08-64 RHSNB 1/2-13 x 8 Gr. 5 ZD
8	532 19 30-03 Bolt/Washer Am 7/16-20	54	521 99 11-01 Nut 1/2-13 Hex Flg Nyloc ZD
11	582 76 05-08 Blade 54cc	61	532 40 03-37 Rod Anti-Sway
14	539 13 18-98 Housing, Mandrel	62	819 13 13-12 Washer 13/32 x 13/16 x 12 Ga.
20	532 19 72-36 Spacer Idler Pulley	63	532 19 42-08 Pin Cotter 5/16 Bow Tie Lock
22	817 49 06-28 Screw THDROL 3/8-16 x 1-3/4	65	873 68 06-00 Nut Crownlock 3/8-16 unc
23	588 43 83-01 Screw 7/16-14 x 2.125 Washer	66	590 73 25-01 Bumper Asm 54cc
24	532 10 53-04 Cap Sleeve	97	532 17 85-15 Washer Hardened
25	587 35 47-01 Spring, Torsion	98	587 35 84-01 Spring Drive
26	532 11 04-52 Nut, Push	116	532 19 34-06 Bolt, Shoulder
27	590 63 22-01 Deflector Shield	117	589 52 73-01 Gauge Wheel
28	539 11 55-74 Bolt Eye 5/16 x 3-1/2	184	873 90 05-00 Nut Lock Hex Flange 5/16-18
29	532 13 14-91 Rod, Hinge	187	532 19 51-61 Stud Fastener w/"D" Anti-Rotation
31	532 18 76-90 Washer Spacer Mandrel	189	587 14 05-02 Arm Susp. Mower Rear
32	532 15 35-35 Pulley, Mandrel	190	532 19 65-39 Bolt Shoulder
33	532 40 02-34 Nut, Flg. Top Lock	192	532 19 84-68 Keeper Belt Idler
36	539 99 05-85 Nut 5/16-18 Hex	196	872 14 06-20 Bolt Rdhd 3/8-16 unc x 2-1/2 Gr. 5
37	532 17 01-65 Bolt Shoulder 5/16-18	242	532 41 55-98 Port Washout
41	584 95 39-01 Bolt Hex Wshr .313 - 18 x 1.19	--	532 41 64-05 Coupling Quick Connect
42	596 95 22-01 Plug, Hole, Square	--	592 61 89-01 Replacement Mower, Complete
43	582 21 96-02 Arm, Idler		
46	532 13 77-29 Screw, Thdroll. 1/4-20 x 5/8		
47	582 23 63-01 V-Belt, Mower		
48	574 19 65-01 Tube Roller		
49	873 90 06-00 Nut, Lock Flg. 3/8-16 unc		

**NOTE:** All component dimensions given in U.S. inches  
1 inch = 25.4 mm

**TRACTOR - MODEL NO. TS 354X (96043024301), PRODUCT NO. 960 43 02 43  
MOWER LIFT**

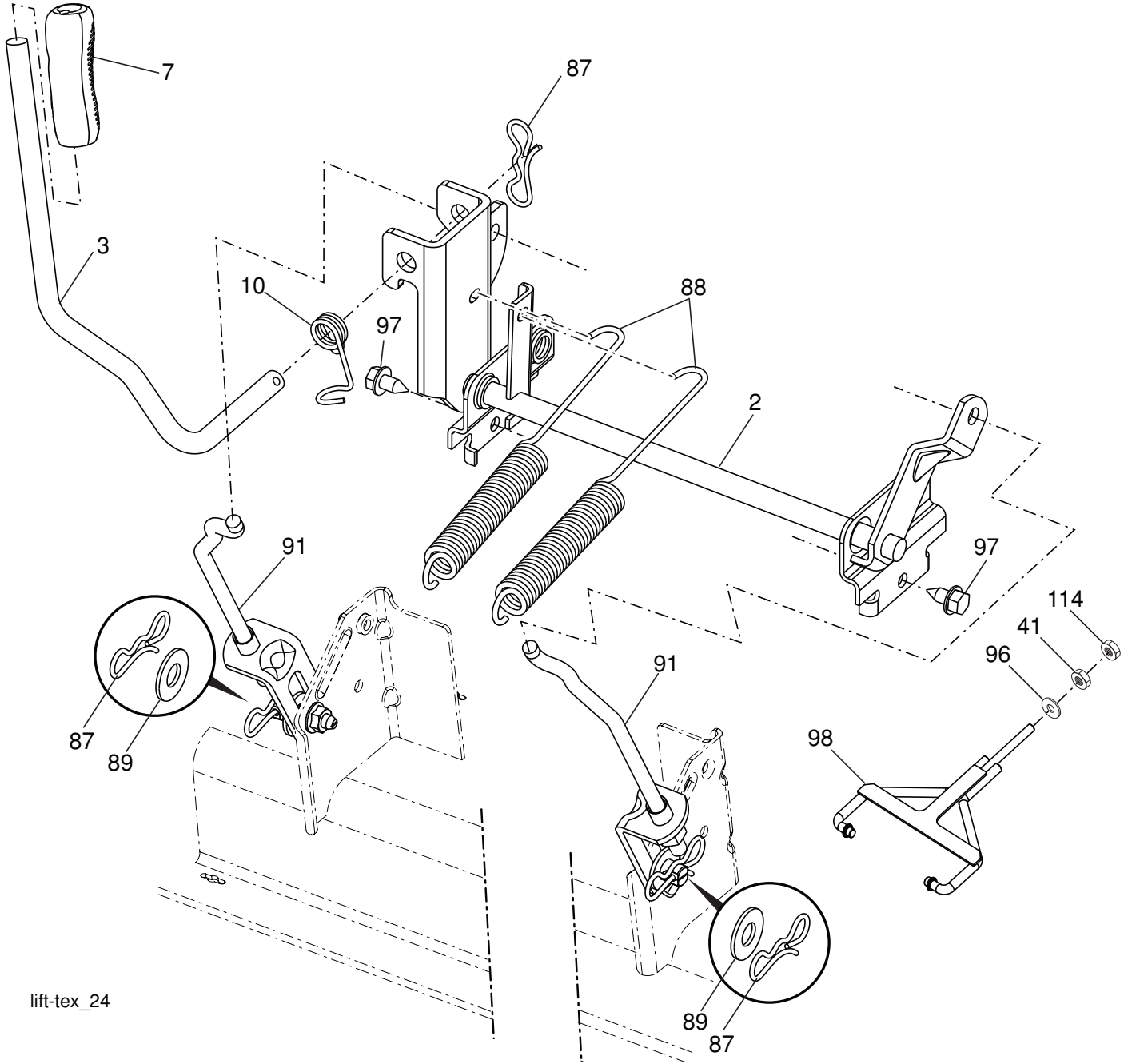

lift-tex\_24

KEY NO.	PART NO.	DESCRIPTION
2	532 42 20-27	Shaft Asm., Lift
3	532 19 52-30	Lever Asm., Lift RH
7	580 96 23-01	Grip, Lever
10	532 19 63-14	Spring Torsion
41	532 17 59-94	Nut Lift Link
87	532 19 42-09	Pin Cotter 7/16 Bow Tie Lock
88	532 19 53-04	Spring Lift Assist
89	819 19 19-12	Washer Clear Zinc

KEY NO.	PART NO.	DESCRIPTION
91	532 40 34-07	Link Lift Susp Mower Rear
96	532 19 52-63	Bushing Spherical
97	817 00 06-12	Screw 3/8-16 x .75
98	589 31 87-03	Link Lift Susp. Front Mower
114	873 36 07-00	Nut Jam 7/16-20

**NOTE:** All component dimensions given in U.S. inches  
1 inch = 25.4 mm

**TRACTOR - MODEL NO. TS 354X (96043024301), PRODUCT NO. 960 43 02 43  
SEAT ASSEMBLY**

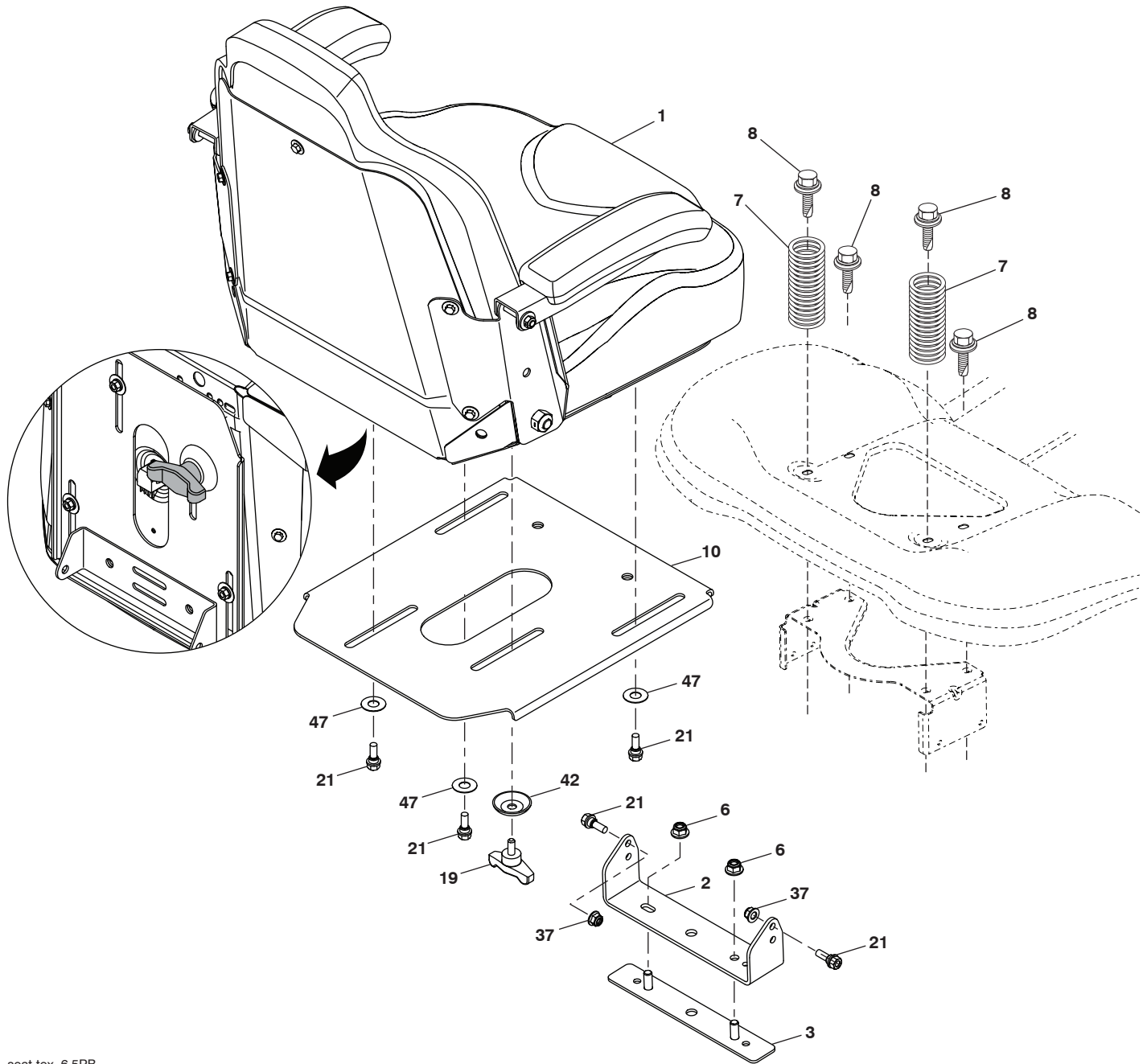

seat-tex\_6.5PB

KEY NO.	PART NO.	DESCRIPTION
1	590 33 73-02	Seat
2	590 33 66-02	Bracket Pivot Fender
3	590 77 76-02	Brkt, Asm Fender
6	521 99 65-01	Nut 3/8-16 Hex Fig Nyloc
7	590 81 23-01	Spring, Seat Cprsn
8	532 17 18-77	Bolt 5/16-18 unc x 3/4 w/Sems
10	590 48 17-02	Seat, Plate, Brkt.
19	590 69 15-01	Knob Seat 5/16-18 x 3/4

KEY NO.	PART NO.	DESCRIPTION
21	532 16 96-12	Bolt, Shoulder 5/16-18
37	539 11 28-99	Nut, Hex 5/16-18 unc
42	532 19 93-71	Washer Cup
47	590 35 11-01	Washer Nylon 50 x 1.12 x 003

**NOTE:** All component dimensions given in U.S. inches  
1 inch = 25.4 mm

# COMO UTILIZAR ESTE MANUAL

Este manual está diseñado para brindarle al comprador un medio para identificar las piezas del tractor para cuando necesite hacer el pedido de un repuesto. Las ilustraciones pueden o no representar los ensambles reales; por lo tanto, no se recomienda utilizar este manual como una guía para ensamblar o desarmar el tractor. Algunos accesorios y piezas están dibujados en tamaños más grandes para identificarlos con mayor facilidad.

Cada tractor tiene su propio número de modelo. El número de modelo del tractor se encuentra en el guardabarros debajo del asiento.

## Soporte / Ayuda

Si necesita asistencia o tiene alguna pregunta acerca de la aplicación, operación, mantenimiento o piezas de su producto:

- Visite nuestro sitio web: [www.husqvarna.com](http://www.husqvarna.com)
- Llámenos de manera gratuita al: 1-800-487-5951

Cuando haga el pedido de una pieza, siempre brinde la siguiente información:

- Producto: "TRACTOR"
- NÚMERO DE MODELO: "TS354X" (96043024301)"
- Número de pieza
- Descripción de la pieza

## ÍNDICE

<b>CALCOMANÍAS.....</b>	<b>21</b>
<b>DIAGRAMA.....</b>	<b>22-23</b>
<b>DIAGRAMA ELÉCTRICO .....</b>	<b>24-25</b>
<b>CHASIS.....</b>	<b>26-27</b>
<b>TRANSMISIÓN .....</b>	<b>28-29</b>
<b>MOTOR .....</b>	<b>30-31</b>
<b>DIRECCIÓN .....</b>	<b>32-33</b>
<b>PLATAFORMA DE LA CORTADORA DE CÉSPED .....</b>	<b>34-35</b>
<b>ELEVACIÓN DE LA CORTADORA DE CÉSPED.....</b>	<b>36</b>
<b>ASIENTO.....</b>	<b>37</b>

**TRACTOR MODELO NO. TS 354X (96043024301), PRODUCTO NO. 960 43 02 43**  
**CALCOMANÍAS**

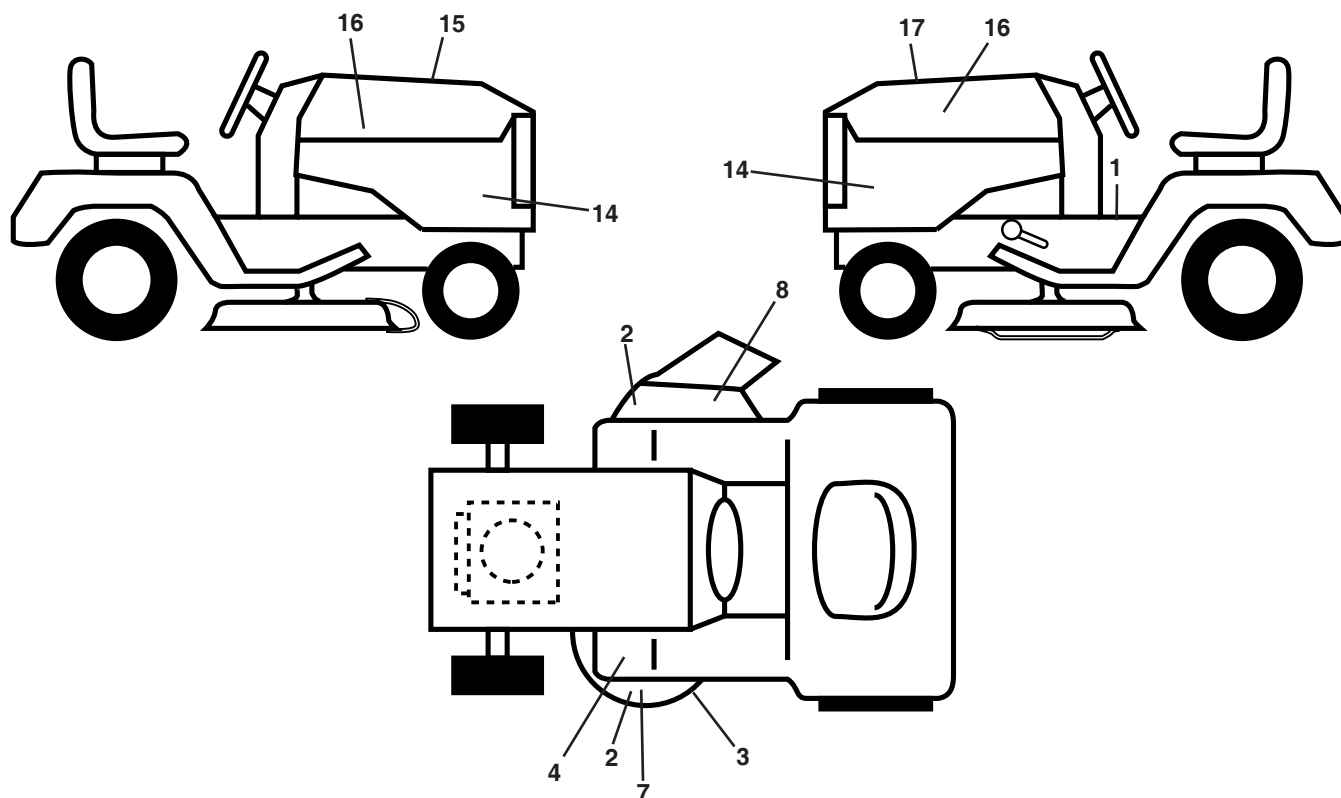

CÓDIGO No.	PIEZA No.	DESCRIPCIÓN
1	581 57 89-01	Calcomanía, Advertencia
2	589 35 79-01	Calcomanía, Ningul n paso
3	592 89 83-01	Calcomanía, Advertencia
4	591 16 47-01	Calcomanía del diagrama de la cortadora de césped
7	593 80 88-01	Calcomanía, 54CC
8	586 97 88-01	Calcomanía, Advertencia
14	591 44 86-01	Calcomanía, Panel
15	532 42 38-29	Calcomanía
16	581 62 73-01	Calcomanía para la capota, logo
17	593 09 12-01	Calcomanía de reemplazo

CÓDIGO No.	PIEZA No.	DESCRIPCIÓN
--	581 57 90-01	Calcomanía, Guardabarros Advertencia
--	581 72 48-01	Calcomanía para la desviación
--	532 43 98-82	Forro del apoyo para los pies izquierdo
--	532 43 98-81	Forro del apoyo para los pies derecho
--	114 06 07-49	Manual del operario (Inglés/Español)
--	114 06 09-33	Manual del operario (Francés)
--	114 06 08-49	Manual de repuestos (Inglés/Español)
--	114 06 10-33	Manual de repuestos (Francés)
--	587 71 00-26	Manual de QSG (Inglés/Español)
--	587 71 01-26	Manual de QSG (Inglés/Francés)

**WHEELS AND TIRES**

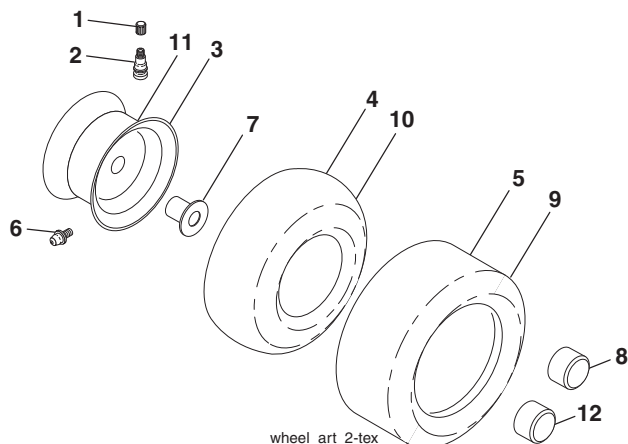

CÓDIGO No.	PIEZA No.	DESCRIPCIÓN
1	532 05 91-92	Tapa de la válvula del neumático
2	532 06 51-39	Vástago de la válvula
3	532 18 18-39	Ensamble de las llantas delanteras
4	532 00 81-34	Cámara delantera
5	593 14 51-01	Neumático delantero 16 x 6.5-8
6	532 12 49-57	Accesorio para engrasar (solo para la rueda delantera)
7	532 12 49-59	Rodamiento de la brida (solo para la rueda delantera)
8	532 17 50-39	Tapa del eje frente
9	593 14 52-01	Neumático trasero 23 x 10.5-12
10	532 00 71-54	Cámara trasera (Mantenimiento sólo)
11	593 14 48-01	Ensamble trasero de la llanta
12	501 50 31-01	Tapa del eje trasero negro
--	532 14 43-34	Sellador para neumáticos (tubo de 10 onzas [283 gr])

**NOTA:** Las dimensiones de todos los componentes están expresadas en pulgadas americanas. 1 pulgada=25,4 mm

## DIAGRAMA

SCH35a-5

### MÓDULO DE CONTROL DEL CORTACÉSPED: ARNESES DEL MOTOR Y DEL TABLERO

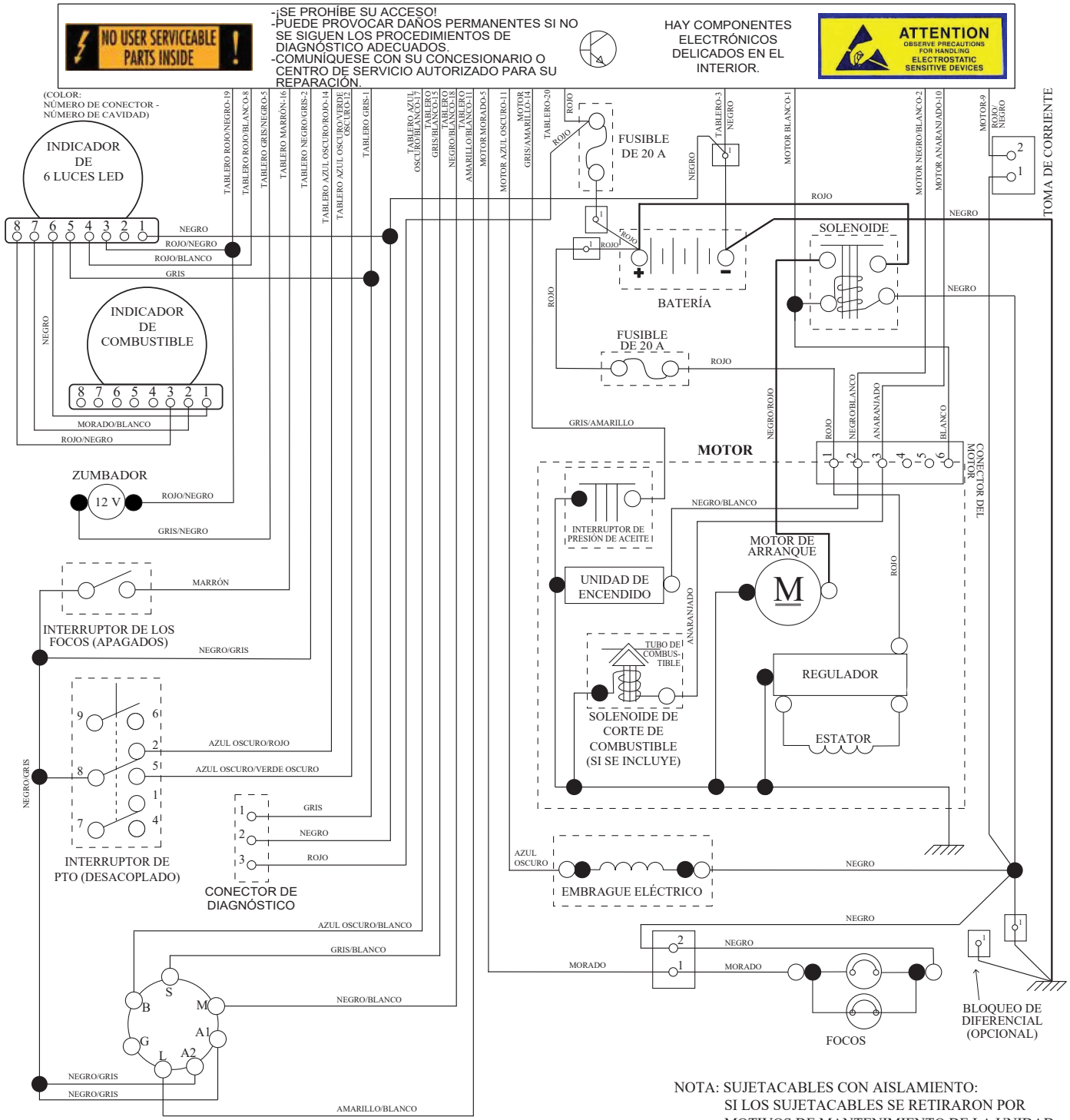

¡SE PROHÍBE SU ACCESO!  
 PUEDE PROVOCAR DAÑOS PERMANENTES SI NO SE SIGUEN LOS PROCEDIMIENTOS DE DIAGNÓSTICO ADECUADOS.  
 COMUNIQUESE CON SU CONCESIONARIO O CENTRO DE SERVICIO AUTORIZADO PARA SU REPARACIÓN.

HAY COMPONENTES ELECTRÓNICOS DELICADOS EN EL INTERIOR.

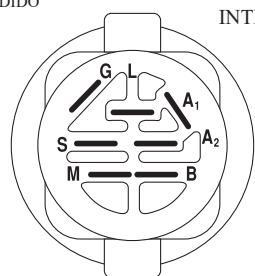

POSICIÓN	DISYUNTOR "CREAR"
OFF (APAGADO)	M+G+A1
EJECUTAR/IGNORAR	B+A1
EJECUTAR	B+A1 L+A2
ENCENDIDO	B+S+A1



NOTA: SUJETACABLES CON AISLAMIENTO: SI LOS SUJETACABLES SE RETIRARON POR MOTIVOS DE MANTENIMIENTO DE LA UNIDAD, SE DEBEN VOLVER A INSTALAR PARA FIJAR ADECUADAMENTE EL CABLEADO.

# TRACTOR MODELO NO. TS 354X (96043024301), PRODUCTO NO. 960 43 02 43

## DIAGRAMA

SCH35b-S

### MÓDULO DE CONTROL DEL CORTACÉSPED: ARNÉS DEL CHASIS

NO USER SERVICEABLE  
PARTS INSIDE

- ¡SE PROHÍBE SU ACCESO!

- PUEDE PROVOCAR DAÑOS IRREVERSIBLES SI NO SE SIGUEN LOS PROCEDIMIENTOS DE DIAGNÓSTICO ADECUADOS.

- COMUNÍQUESE CON SU CONCESIONARIO O CENTRO DE SERVICIO AUTORIZADO PARA SU REPARACIÓN.

HAY COMPONENTES  
ELECTRÓNICOS DELICADOS  
EN EL INTERIOR.

ATTENTION

OBSERVE PRECAUTIONS  
FOR HANDLING  
ELECTROSTATIC  
SENSITIVE DEVICES

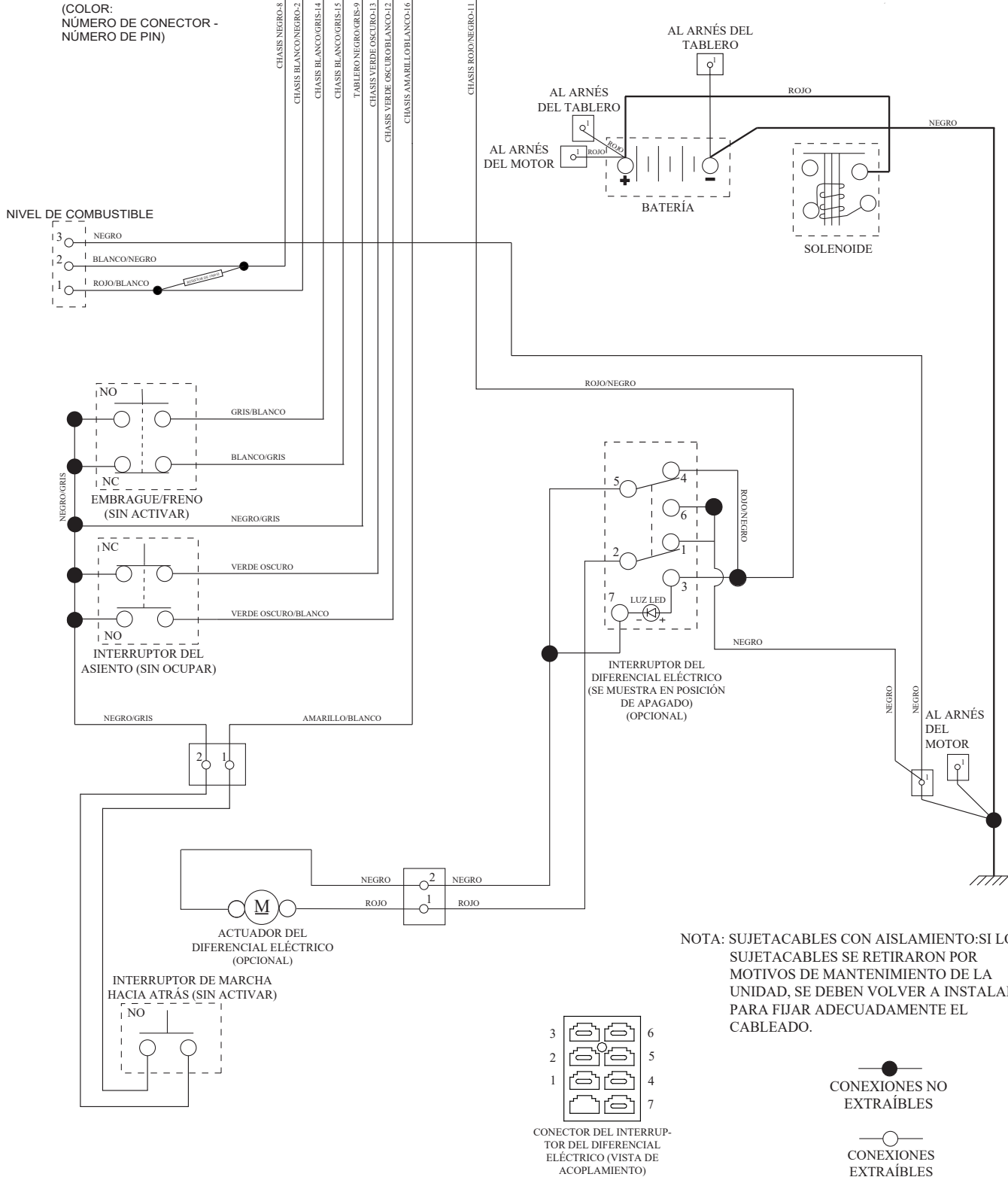

TRACTOR MODELO NO. TS 354X (96043024301), PRODUCTO NO. 960 43 02 43

DIAGRAMA ELÉCTRICO

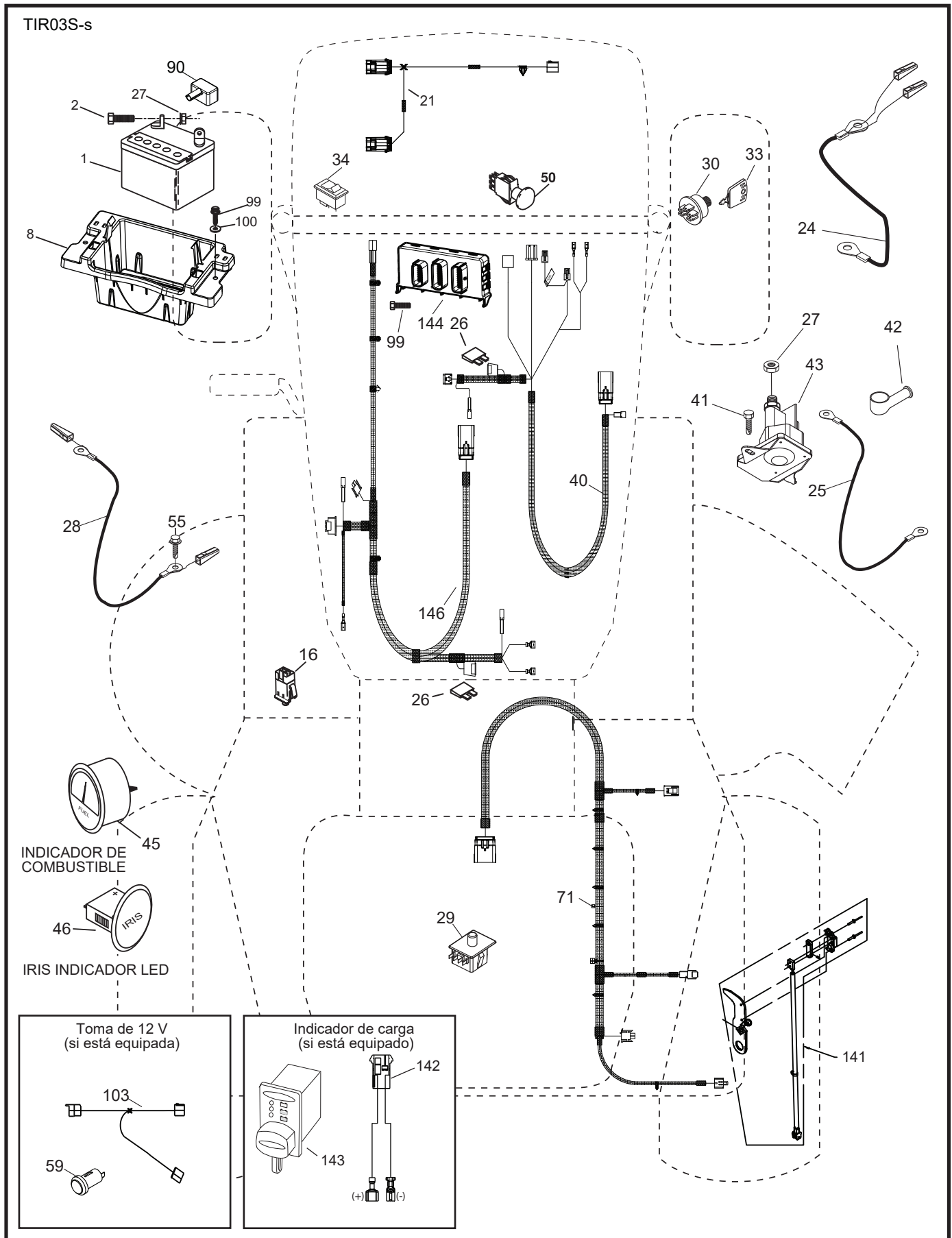



**TRACTOR MODELO NO. TS 354X (96043024301), PRODUCTO NO. 960 43 02 43**  
**DIAGRAMA ELÉCTRICO**

<b>CÓDIGO No.</b>	<b>PIEZA No.</b>	<b>DESCRIPCIÓN</b>
1	532 16 34-65	Batería
2	874 76 04-12	Perno de cabeza hexagonal de 1/4-20 x 3/4
8	587 20 51-01	Caja de la batería
16	532 17 61-38	Interruptor corta corriente a presión
21	585 43 64-01	Cableado del enchufe para la luz
24	590 22 38-01	Cable Iris
25	585 55 55-01	Cable
26	532 17 51-58	Fusible
27	873 51 04-00	Tuerca hexagonal Keps de 1/4-20 unc
28	590 22 37-01	Cable a tierra
29	587 64 84-01	Interruptor del asiento
30	532 19 33-50	Interruptor de encendido
33	532 41 19-35	Llave/cadena
34	532 11 07-12	Interruptor de luz/de restauración
40	590 19 32-01	Cableado de encendido Iris
41	817 72 04-08	Tornillo
42	532 13 15-63	Cubierta de la terminal
43	582 04 28-01	Solenoides
45	590 64 59-01	Indicador de combustible
46	594 72 15-01	Indicador seis LED
50	582 10 76-01	Interruptor PTO
55	817 06 05-12	Tornillo de 5/16-18 x 3/4
59	532 40 03-03	Salida 12-Voltio
71	590 19 33-01	Cableado de encendido, chasis Iris
90	532 43 53-95	Tapa de los bornes de la batería
99	817 67 04-12	Tornillo 1/4-20 x 3/4
100	819 09 14-16	Arandela
141	532 42 12-25	G700/G730 ROS
144	590 56 80-01	Unidad de control IRIS
146	590 19 34-01	Arnés del motor

**NOTA:** Las dimensiones de todos los componentes están expresadas en pulgadas americanas. 1 pulgada = 25,4 mm



**TRACTOR MODELO NO. TS 354X (96043024301), PRODUCTO NO. 960 43 02 43  
CHASIS**

<b>CÓDIGO No.</b>	<b>PIEZA No.</b>	<b>DESCRIPCIÓN</b>	<b>CÓDIGO No.</b>	<b>PIEZA No.</b>	<b>DESCRIPCIÓN</b>
2	580 43 44-01	Barra de tracción	199	532 19 82-59	Chapa
3	532 44 44-81	Aplica Submontaje	202	532 43 97-28	Salida de Ventilación (LD)
5	590 74 00-17	Tablero	203	532 43 97-27	Salida de Ventilación (LI)
14	532 44 11-77	Capota	204	532 43 57-14	Salida de Ventilación superior
15	585 42 03-01	Lente izquierdo de la parrilla	205	532 43 97-30	Camisa de Capota (LD)
18	587 52 34-01	Parrilla	206	532 43 97-29	Camisa de Capota (LI)
25	585 42 02-01	Lente derecho de la parrilla	207	585 42 00-02	Bisel derecho
36	817 06 05-12	Tornillo de 5/16-18 x 3/4	208	585 42 01-02	Bisel izquierdo
37	590 53 47-02	Guardabarros	214	532 19 91-45	Cierre
58	532 19 43-14	Soporte de Guardabarros	217	532 40 91-67	Varilla giratoria
68	539 99 08-58	Tornillo de 5/16-18 x 1/2	218	532 19 63-95	Tope
125	581 68 48-01	Soporte	221	532 19 89-09	Reflector (LI)
130	532 41 63-58	Tornillo No. 10 x 0,75	228	532 19 51-61	Sujetador del travesaño
137	532 40 75-90	Cubierta Tablero	235	532 40 61-29	Separador del guardabarros
146	581 85 79-01	Perno	236	873 93 05-00	Tuerca de presión 5/16-18 unc
150	532 43 97-74	Cubierta	281	817 00 06-16	Tornillo 3/8-16 x 1
151	532 43 66-70	Soporte de Capota	296	585 42 05-01	Luz LED (LI)
152	532 43 98-70	Protector contra oscurecimiento	297	586 18 29-01	Parte movable reflexivo (LI)
162	532 14 24-32	Tornillo	299	585 42 04-01	Luz LED(LD)
165	532 19 43-30	Soporte de Tanque de Gasolina	306	873 90 06-00	Tuerca
175	590 60 77-02	Travesaño	335	532 44 82-04	Cubierta (LD)
176	532 40 07-76	Tornillo de 10-24 x 5/8	336	532 44 53-09	Cubierta (LI)
177	532 19 52-28	Buje de dirección	350	532 44 51-43	Cierre del árbol de navidad
180	593 34 63-01	Chasis	375	586 90 82-01	Cubierta Capota
182	532 40 68-59	Tablero inferior	378	590 84 98-01	Cojinete
183	874 52 05-20	Perno 5/16-18 x 1-1/4	379	593 20 69-02	Refuerzo de la placa del chasis
189	817 00 05-12	Tornillo	--	532 43 18-82	Protector del cepillo
191	586 18 28-01	Parte movable reflexivo (LD)			
194	873 90 05-00	Tuerca de presión de 5/16-18			
196	532 43 96-74	Ensamble de la consola de la plataforma de elevación			

**NOTA:** Las dimensiones de todos los componentes están expresadas en pulgadas americanas. 1 pulgada = 25,4 mm

TRACTOR MODELO NO. TS 354X (96043024301), PRODUCTO NO. 960 43 02 43  
TRANSMISIÓN

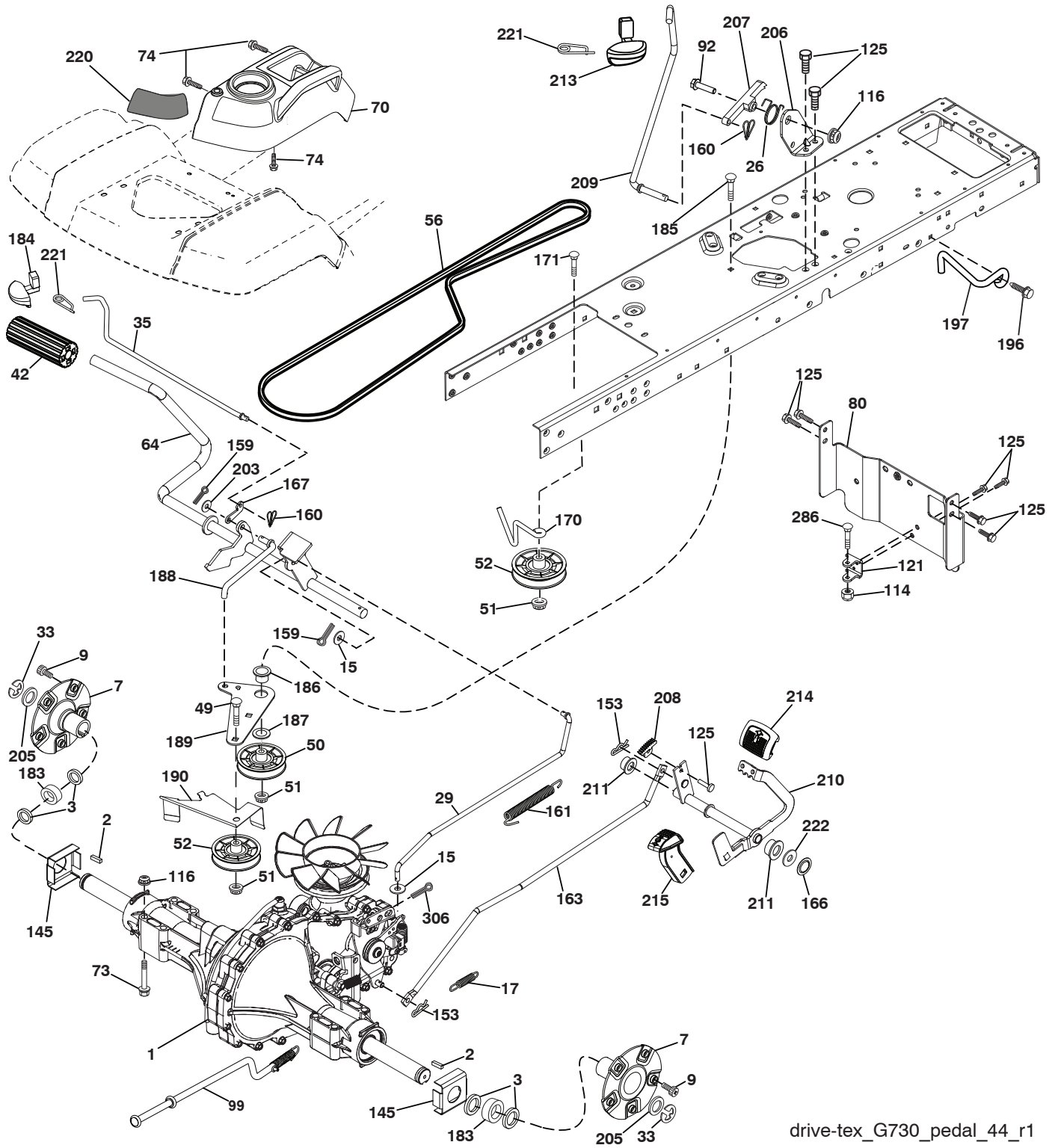

drive-tex\_G730\_pedal\_44\_r1

# TRACTOR MODELO NO. TS 354X (96043024301), PRODUCTO NO. 960 43 02 43

## TRANSMISIÓN

CÓDIGO No.	PIEZA No.	DESCRIPCIÓN	CÓDIGO No.	PIEZA No.	DESCRIPCIÓN
1	-----	Transeje, Hydro G7-BCBB-1XDC-1FCA (420331)(Haga el pedido de las piezas al fabricante del transeje.)	167	532 40 52-57	Pestillo del freno de mano
			170	532 19 43-22	Sujetador de la correa
			171	872 11 06-16	Perno 3/8-16 unc x 2
2	539 91 27-57	Llave .25 x 1.25	183	501 05 15-01	Separador
3	532 00 75-63	Tuerca	184	587 65 37-01	Manija del freno de mano
7	586 93 54-02	Ensamble del cubo trasero	185	872 11 06-22	Perno RHD 3/8-16 unc x 2-3/4
9	532 14 00-80	Perno	186	532 19 43-21	Espaciador de retención
15	819 13 13-16	Arandela 13/32 x 13/16 x calibre 16	187	819 13 32-10	Arandela
17	532 19 72-96	Resorte de freno	188	582 21 70-01	Mecanismo de desplazamiento de la varilla de mando del embrague
26	532 19 96-79	Resorte de travesía			
29	532 41 81-86	Varilla del freno	189	532 19 43-17	Palanca acodada del mecanismo de desplazamiento
33	812 00 00-53	Aro "E"			
35	590 60 59-02	Varilla del freno de mano	190	532 19 43-18	Sujetador de la palanca acodada del mecanismo de desplazamiento
42	532 12 48-72	Cubierta del pedal			
49	872 11 06-14	Perno RDHD 3/8-16 unc x 1-3/4	196	817 00 06-16	Tornillo 3/8-16 x 1
50	532 19 43-27	Polea loca plana	197	585 65 86-01	Mecanismo de desplazamiento
51	873 90 06-00	Tuerca de presión de 3/8-16	203	819 11 11-16	Tuerca 11/32 x 11/16 x calibre 16
52	532 19 43-26	Polea loca con ranura en V con un desplazamiento	205	532 12 38-00	Tuerca 1-1/32 x 1-5/8 x calibre 16
			206	532 44 85-96	Soporte de la travesía
56	532 14 02-94	Correa trapezoidal de la transmisión	207	587 03 14-01	Cierre del control de travesía
64	532 19 78-65	Ensamble del eje Control del pedal de freno	208	532 19 78-69	Travesía del control del sector
			209	590 52 78-02	Travesía del control de Rod
70	532 43 96-61	Ensamble de la consola	210	532 19 78-60	Ensamble del eje de balancín. Control del pedal
73	874 49 05-48	Perno 5/16-18 3.75			
74	532 14 24-32	Tornillo 1/4 x 1/2	211	532 12 01-83	Buje
80	532 41 81-84	Correa de torsión	213	532 40 31-19	Travesía del control de la perilla
92	874 76 05-20	Tornillo 5/16-18 x 1/2	214	532 42 12-63	Pedal adelante
99	590 64 02-01	Varilla de desviación	215	586 60 65-02	Revés del pedal
114	873 80 05-00	Tuerca 5/16-18 unc	220	532 19 89-08	Reflector derecho
116	873 90 05-00	Tuerca 5/16-18	221	532 40 31-87	Abrazadera de retención del resorte de la manija
121	532 17 56-11	Bracket Strap Torque			
125	817 00 05-12	Tornillo 5/16-18 x 3/4	222	879 21 20-10	Tuerca 21/32 x 1-1/4 x calibre 10
145	532 16 31-68	Tuerca	286	872 01 05-20	Tornillo 5/16-18 x 2.50
153	532 12 47-88	Retén del resorte	306	876 02 04-16	Pasador de chaveta de 1/8 x 1
159	876 02 04-12	Pasador de chaveta de 1/8 x 3/4			
160	532 16 94-84	Abrazadera de retención			
161	532 10 57-09	Resorte de retorno del embrague			
163	532 41 81-85	Control del pedal de la barra			
166	532 42 91-64	Tuerca			

**NOTA:** Las dimensiones de todos los componentes están expresadas en pulgadas americanas. 1 pulgada = 25,4 mm

**TRACTOR MODELO NO. TS 354X (96043024301), PRODUCTO NO. 960 43 02 43**  
**MOTOR**

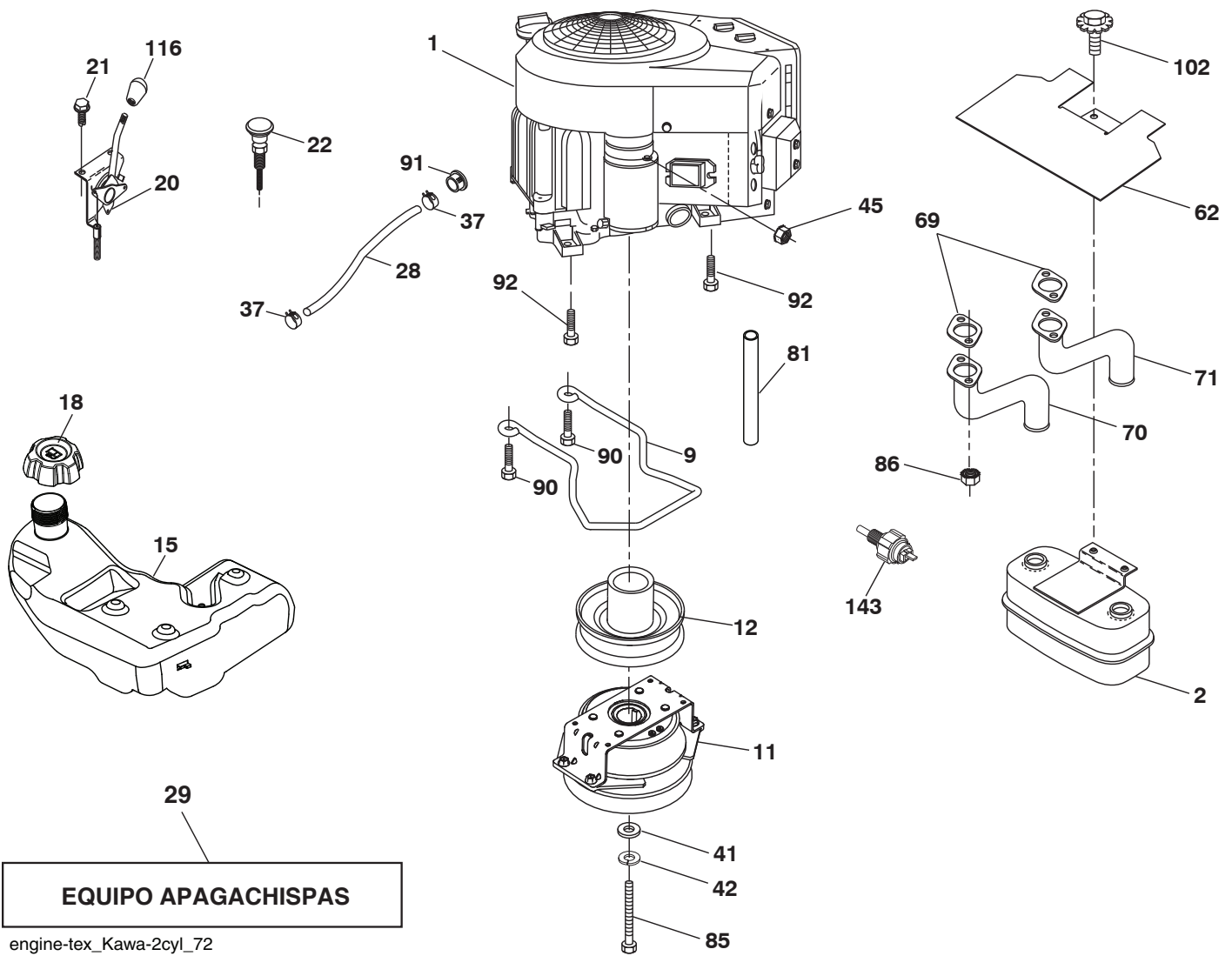

**EQUIPO APAGACHISPAS**

engine-tex\_Kawa-2cyl\_72

**TRACTOR MODELO NO. TS 354X (96043024301), PRODUCTO NO. 960 43 02 43  
MOTOR**

<b>CÓDIGO No.</b>	<b>PIEZA No.</b>	<b>DESCRIPCIÓN</b>
1	- - - - -	Motor KAWA modelo No. FR730V-ES04 (445363)(Haga el pedido de las piezas al fabricante del motor.)
2	589 81 87-01	Silenciador
9	501 83 26-02	Ensamble del sujetador de la correa del motor
11	587 24 14-01	Embrague de eléctrico
12	532 19 43-43	Polea del motor
15	590 59 94-02	Tanque de Gasolina de 4,0 R
18	585 12 48-01	Tapa
20	532 42 43-41	Control del regulador
21	532 41 63-58	Tornillo No. 10 x 0,75 con rosca reforzada
22	532 18 95-41	Control de la estrangulación del motor
28	532 40 11-35	Línea de combustible
29	532 13 71-80	Equipo apagachispas
37	532 12 34-87	Abrazadera de la manguera
41	532 12 61-97	Arandela 1-1/2 x 15/32 x .250
42	539 99 02-47	Arandela de presión de 7/16
45	873 51 04-00	Tuerca
62	532 14 66-29	Silenciador con pantalla térmica
69	532 17 81-51	Junta
70	583 95 56-01	Tubo de escape izquierdo
71	583 95 57-01	Tubo de escape derecho
81	532 14 84-56	Tubo de drenaje
85	501 60 69-01	Perno de 7/16-20 x 3.0 x grado 5
86	532 18 43-62	Tuerca
90	817 00 06-16	Tornillo de 3/8-16 x 1
91	532 18 74-95	Buje
92	817 12 06-16	Tornillo 3/8-16 x 1
102	817 00 05-12	Tornillo 5/16-18 x 3/4
116	539 13 26-24	Tacto suave de la perilla
143	590 04 44-01	Palanca de presión del aceite

**NOTA:** Las dimensiones de todos los componentes están expresadas en pulgadas americanas. 1 pulgada = 25,4 mm  
Para las piezas del servicio y de recambio del motor, llame el número gratis para su fabricante del motor enumerado abajo:  
Kawasaki 1-949-460-5688





**TRACTOR MODELO NO. TS 354X (96043024301), PRODUCTO NO. 960 43 02 43  
ENSAMBLE DE LA DIRECCIÓN**

<b>CÓDIGO No.</b>	<b>PIEZA No.</b>	<b>DESCRIPCIÓN</b>
1	532 43 97-40	Volante de dirección
2	532 19 59-68	Ensamble del eje delantero
4	532 40 30-89	Ensamble del husillo izquierdo
5	532 40 30-90	Ensamble del husillo derecho
6	532 12 49-31	Pista del rodamiento para reforzar el impulso
7	532 12 17-48	Arandela de 25/32 x 1-5/8 calibre 16
8	812 00 00-29	Abrazadera del aro No. T5304-75
9	532 12 12-32	Tapa del husillo
13	532 12 17-49	Arandela de 25/32 x 1-1/4 calibre 16
14	539 99 01-18	Arandela 3/8
15	873 54 06-00	Tuerca de 3/8-24 unf
16	587 01 60-02	Eje de dirección
19	532 19 47-29	Placa de dirección
21	586 84 02-01	Adaptador del volante de dirección
22	585 02 99-01	Rodamiento
26	532 43 97-43	Inserto del volante de dirección
27	819 21 16-16	Arandela
28	817 00 06-12	Tornillo de 3/8-16 x 3/4
35	532 19 47-32	Engranaje del sector de la placa
45	587 01 64-01	Arandela 3/8 ID 2-3/8 OD calibre 12 PLTD
50	873 90 06-00	Tuerca 3/8-16 unc
53	532 18 89-67	Arandela reforzada de, 793 x 1,637 x 0,060
54	874 76 06-36	Tornillo 3/8-16 unc x 2-1/4
55	532 41 47-36	Tornillo 3/8-16 unc x 2-1/4
58	532 19 47-47	Perno de tope del sector del pivote CFM
59	532 19 47-48	Arandela de empuje del sector de dirección
60	873 97 10-00	Tuerca de 5/8-11
61	588 79 44-02	Barra de acoplamiento izquierda
62	588 79 45-02	Barra de acoplamiento derecha
63	817 00 05-12	Tornillo de 5/16-18 x 3/4
64	532 19 98-49	Abrazadera de retención del resorte de la dirección
65	532 19 47-34	Apoyo del árbol delantero
66	871 02 07-48	Perno de cabeza hexagonal con brida acanalada de 7/16-14 x 3
67	532 19 47-37	Buje PM del eje delantero
68	873 90 07-00	Tuerca de 7/16-14 grado 5
69	532 19 91-62	Arandela de 1,5 x 0,505 x 0,118
70	585 33 88-01	Soporte de la plataforma delantera
75	580 68 37-01	Piñón
76	580 68 36-01	Tornillo
78	532 05 70-79	Tuerca
122	532 44 49-62	Tapa

**NOTA:** Las dimensiones de todos los componentes están expresadas en pulgadas americanas. 1 pulgada = 25,4 mm

TRACTOR MODELO NO. TS 354X (96043024301), PRODUCTO NO. 960 43 02 43  
PLATAFORMA DE LA CORTADORA DE CÉSPED

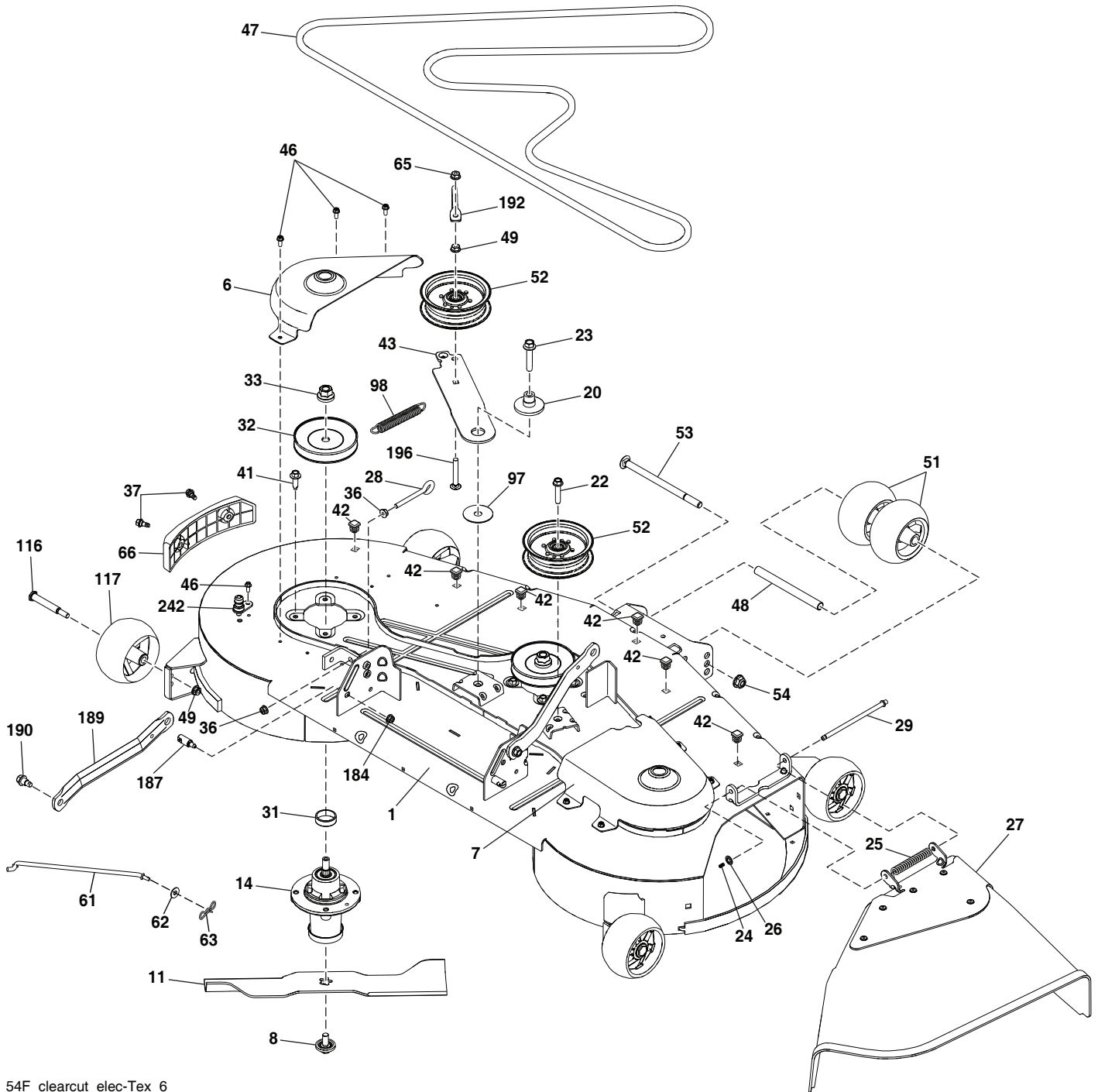

54F\_clearcut\_elec-Tex\_6

**TRACTOR MODELO NO. TS 354X (96043024301), PRODUCTO NO. 960 43 02 43  
PLATAFORMA DE LA CORTADORA DE CÉSPED**

<b>CÓDIGO No.</b>	<b>PIEZA No.</b>	<b>DESCRIPCIÓN</b>	<b>CÓDIGO No.</b>	<b>PIEZA No.</b>	<b>DESCRIPCIÓN</b>
1	588 54 90-02	Carcasa de la cortadora de césped	53	872 14 08-64	RHSNB 1/2--13 x / Gr. 5 ZD
6	590 03 43-03	Brazo de la suspensión	54	521 99 11-01	Tuerca 1/2-13 Hex Flg
7	590 30 42-03	Tornillo #10 x 0.750 BOS	61	532 40 03-37	Barra contra la inclinación lateral
8	532 19 30-03	Perno/arandela del ensamble de 7/16-20	62	819 13 13-12	Arandela 13/32 x 13/16 x calibre 12
11	582 76 05-08	Cuchilla de la cortadora	63	532 19 42-08	Perno de tope
14	539 13 18-98	Carcasa del mandril	65	873 68 06-00	Bloqueo de corona de tuerca 3/8-16 unc
20	532 19 72-36	Polea loca	66	590 73 25-01	Parachoques 54cc
22	817 49 06-28	Tornillo 3/8-16 x 1-3/4	97	532 17 85-15	Arandela
23	588 43 83-01	Tornillo 3/8-16 x 1-3/4 arandela	98	587 35 84-01	Resorte
24	532 10 53-04	Tapa de la manga	116	532 19 34-06	Perno
25	587 35 47-01	Resorte de torsión del deflector	117	589 52 73-01	Calibrador de la rueda
26	532 11 04-52	Tuerca de presión	184	873 90 05-00	Sujetador del travesaño
27	590 63 22-01	Protector del deflector	187	532 19 51-61	Perno del perno prisionero
28	539 11 55-74	Perno 5/16-18	189	587 14 05-02	Tuerca de presión hexagonal con brida
29	532 13 14-91	Varilla de la bisagra	190	532 19 65-39	Perno
31	532 18 76-90	Arandela del separador	192	532 19 84-68	Sujetador
32	532 15 35-35	Polea del mandril	196	872 14 06-20	Perno 3/8-16 unc x 2-1/2 grado 5
33	532 40 02-34	Tuerca de seguridad con brida	242	532 41 55-98	Puerto de lavado de la cubierta
36	539 99 05-85	Tuerca de 5/16-18 Hex	--	532 41 64-05	Acoplador
37	532 17 01-65	Perno 5/16-18	--	592 61 89-01	Reemplazo de la cortadora de césped, completa
41	584 95 39-01	Perno .313 - 18 x 1.19			
42	596 95 22-01	Enchufe cuadrado			
43	582 21 96-02	Resorte de torsión de retención			
46	532 13 77-29	Tornillo			
47	582 23 63-01	Soporte del cable de embrague			
48	574 19 65-01	Rodillo, m			
49	873 90 06-00	Tuerca Flg. 3/8-16 unc			
51	574 16 96-01	Calibradora,			
52	532 19 73-79	Polea			

**NOTA:** Las dimensiones de todos los componentes están expresadas en pulgadas americanas. 1 pulgada = 25,4 mm

**TRACTOR MODELO NO. TS 354X (96043024301), PRODUCTO NO. 960 43 02 43**  
**ELEVACIÓN DE LA CORTADORA DE CÉSPED**

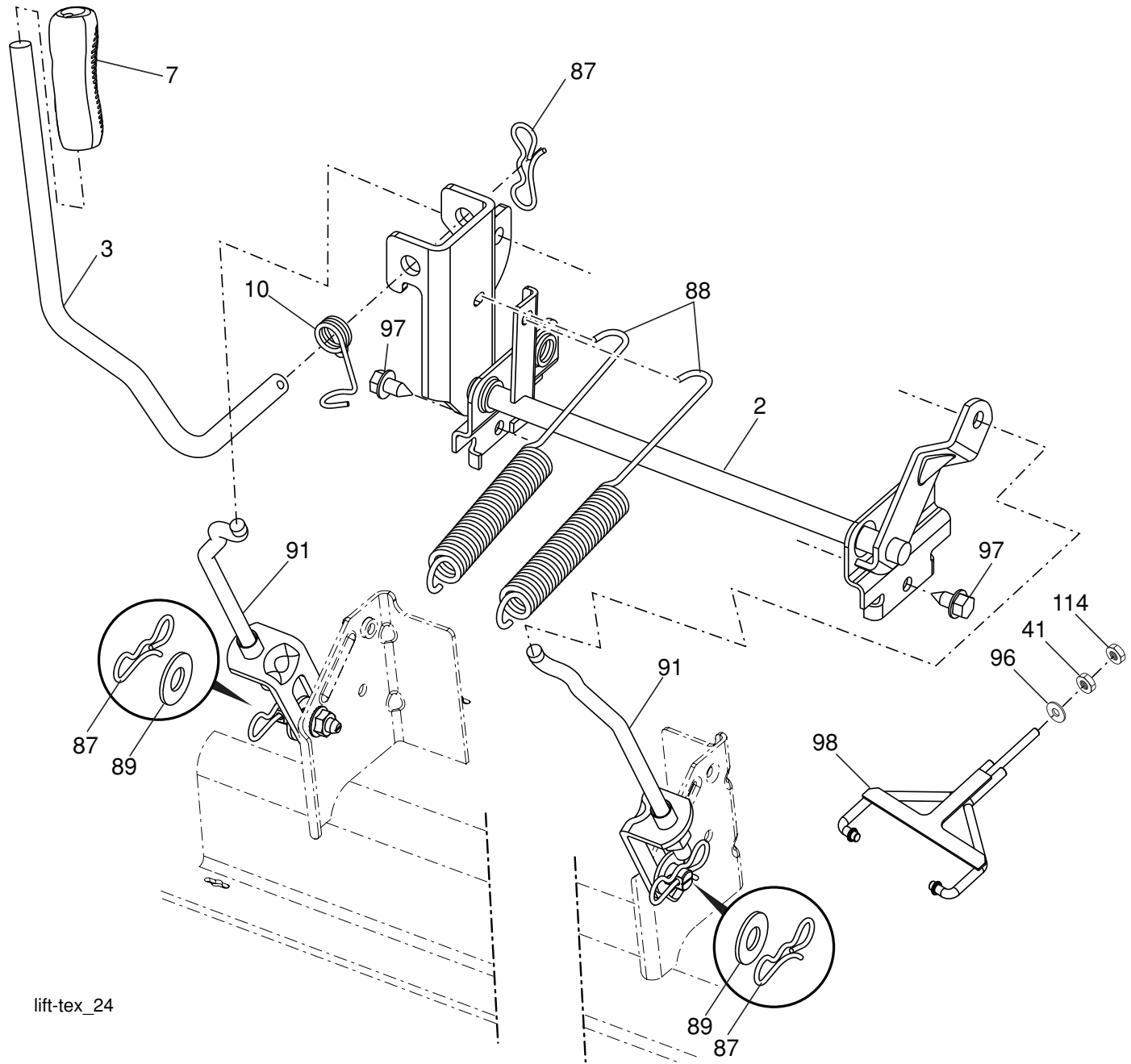

CÓDIGO No.	PIEZA No.	DESCRIPCIÓN
2	532 42 20-27	Ensamble del eje de la elevación
3	532 19 52-30	Ensamble de la palanca de elevación derecha
7	580 96 23-01	Mango de la palanca
10	532 19 63-14	Resorte de torsión
41	532 17 59-94	Tuerca
87	532 19 42-09	Pasador de chaveta de 7/16 con bloqueo en forma de mariposa
88	532 19 53-04	Resorte de ayuda de la elevación
89	819 19 19-12	Arandela de zinc transparente

CÓDIGO No.	PIEZA No.	DESCRIPCIÓN
91	532 40 34-07	Ensamble del acoplamiento Elevación trasera
96	532 19 52-63	Buje
97	817 00 06-12	Tornillo de 3/8-16 x 0,75
98	589 31 87-03	Acoplamiento frontal de la elevación de la cortadora de césped
114	873 36 07-00	Tuerca 7/16-20

**NOTA:** Las dimensiones de todos los componentes están expresadas en pulgadas americanas. 1 pulgada = 25,4 mm

**TRACTOR MODELO NO. TS 354X (96043024301), PRODUCTO NO. 960 43 02 43  
ENSAMBLE DEL ASIENTO**

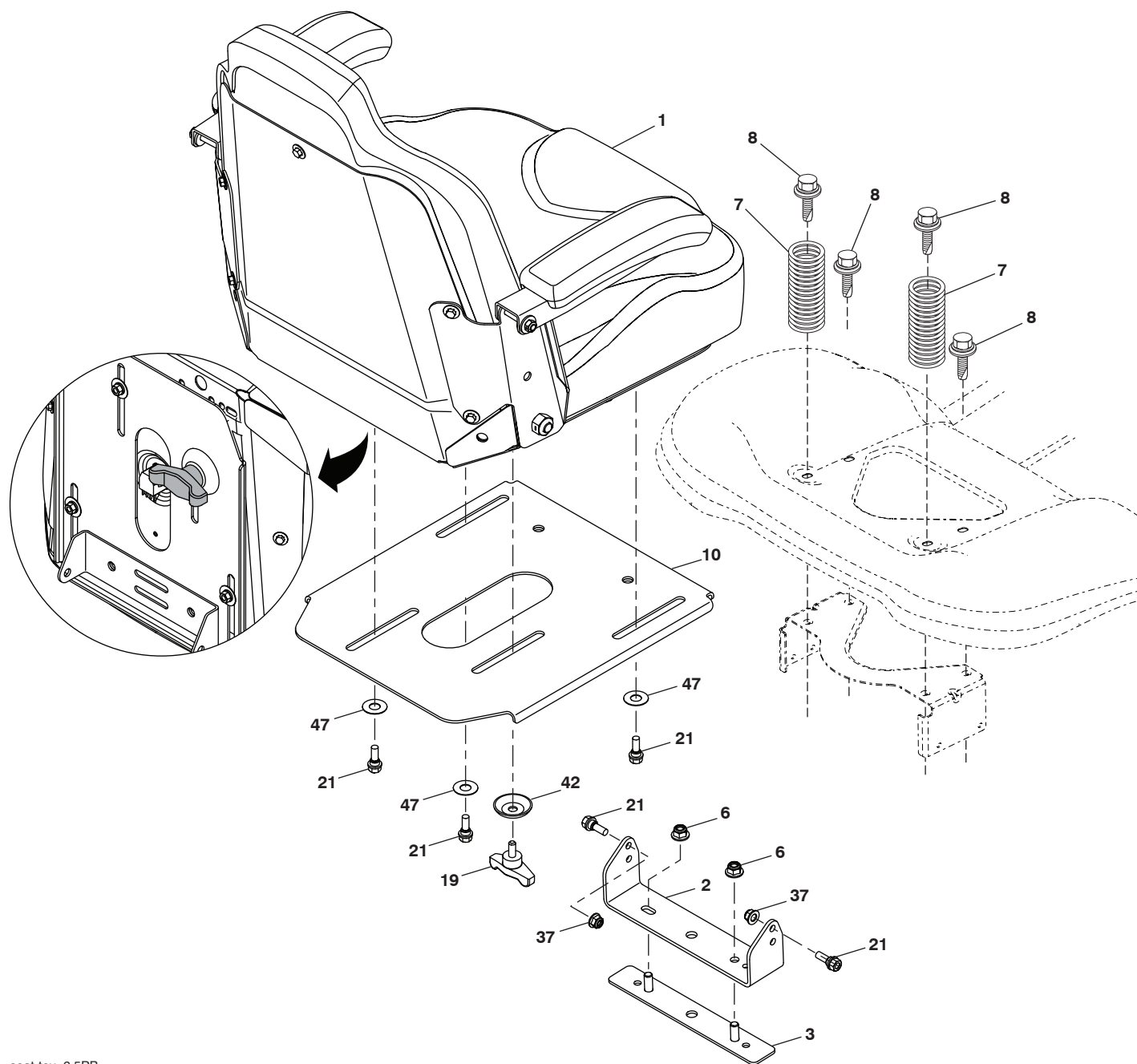

seat-tex\_6.5PB

CÓDIGO No.	PIEZA No.	DESCRIPCIÓN
1	590 33 73-02	Asiento
2	590 33 66-02	Soporte pivotante del guardabarros
3	590 77 76-02	Conector del ensamble del guardabarros
6	521 99 65-01	Tuerca de 3/8 -16
7	590 81 23-01	Resorte del asiento
8	532 17 18-77	Perno de 5/16" unc x 3/4"
10	590 48 17-02	Bandeja del asiento

CÓDIGO No.	PIEZA No.	DESCRIPCIÓN
19	590 69 15-01	Asiento perilla 5/16-18 x 3/4
21	532 16 96-12	Perno de tope de 5/16-18
37	539 11 28-99	Tuerca de 5/16-18
42	532 19 93-71	Arandela taza
47	590 35 11-01	Arandela de nylon 50 x 1.12 x 003

**NOTA:** Las dimensiones de todos los componentes están expresadas en pulgadas americanas. 1 pulgada = 25,4 mm

---

# NOTES/AVISO

---

---

# NOTES/AVISO

---



[www.husqvarna.com](http://www.husqvarna.com)