

REPAIR PARTS MANUAL
MODEL NO. 990370
Lawn Tractor

CRAFTSMAN®

HOW TO USE THIS MANUAL

This manual is designed to provide the customer with a means to identify the parts on his/her tractor when ordering repair parts. The illustrations may or may not represent the actual assemblies; therefore, it is not recommended to use this manual as a guide to assemble or disassemble the tractor. Some hardware and parts are drawn larger in order to more readily identify them.

Each tractor has its own model number.

The model number for your tractor can be found on the fender under the seat.

When ordering parts, always give the following information:

- Product - Lawn Tractor
- MODEL NUMBER - **990370**
- Part Number
- Part Description

TABLE OF CONTENTS

SCHEMATIC	3
ELECTRICAL.....	4-5
CHASSIS	6-7
DRIVE.....	8-9
ENGINE.....	10-11
STEERING	12-13
MOWER DECK.....	14-15
MOWER LIFT.....	16
SEAT	17
DECALS.....	18
TRANSAXLE BREAKDOWN	20-21
ENGINE BREAKDOWN.....	22-25
WARRANTY.....	BACK COVER

TRACTOR - - MODEL NUMBER 917.990370

SCHEMATIC

SCH12

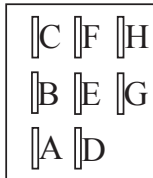
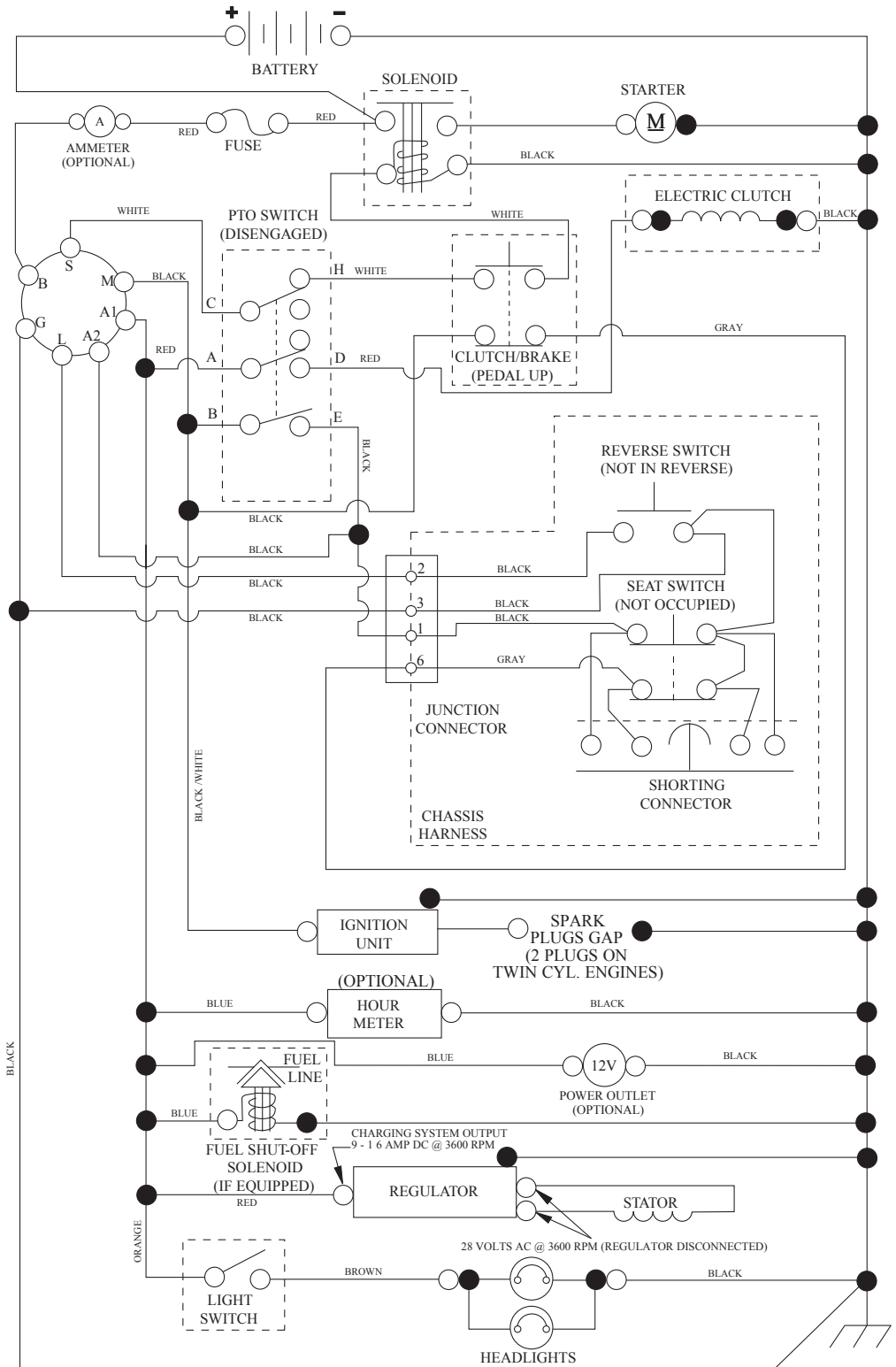

PTO SWITCH (MATING SIDE)

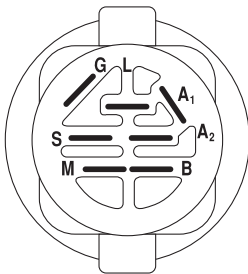

POSITION	CIRCUIT "MAKE"
OFF	M+G+A1
RUN/OVERRIDE	B+A1
RUN	B+A1 L+A2
START	B + S + A1

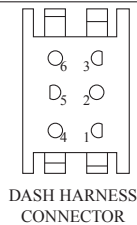
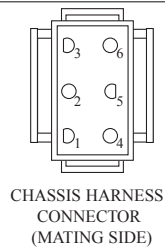

WIRING INSULATED CLIPS
NOTE: IF WIRING INSULATED CLIPS WERE REMOVED FOR SERVICING OF UNIT, THEY SHOULD BE RE-INSTALLED TO PROPERLY SECURE YOUR WIRING.

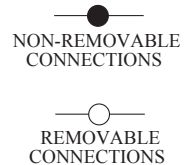

TRACTOR - - MODEL NUMBER 917.990370

ELECTRICAL

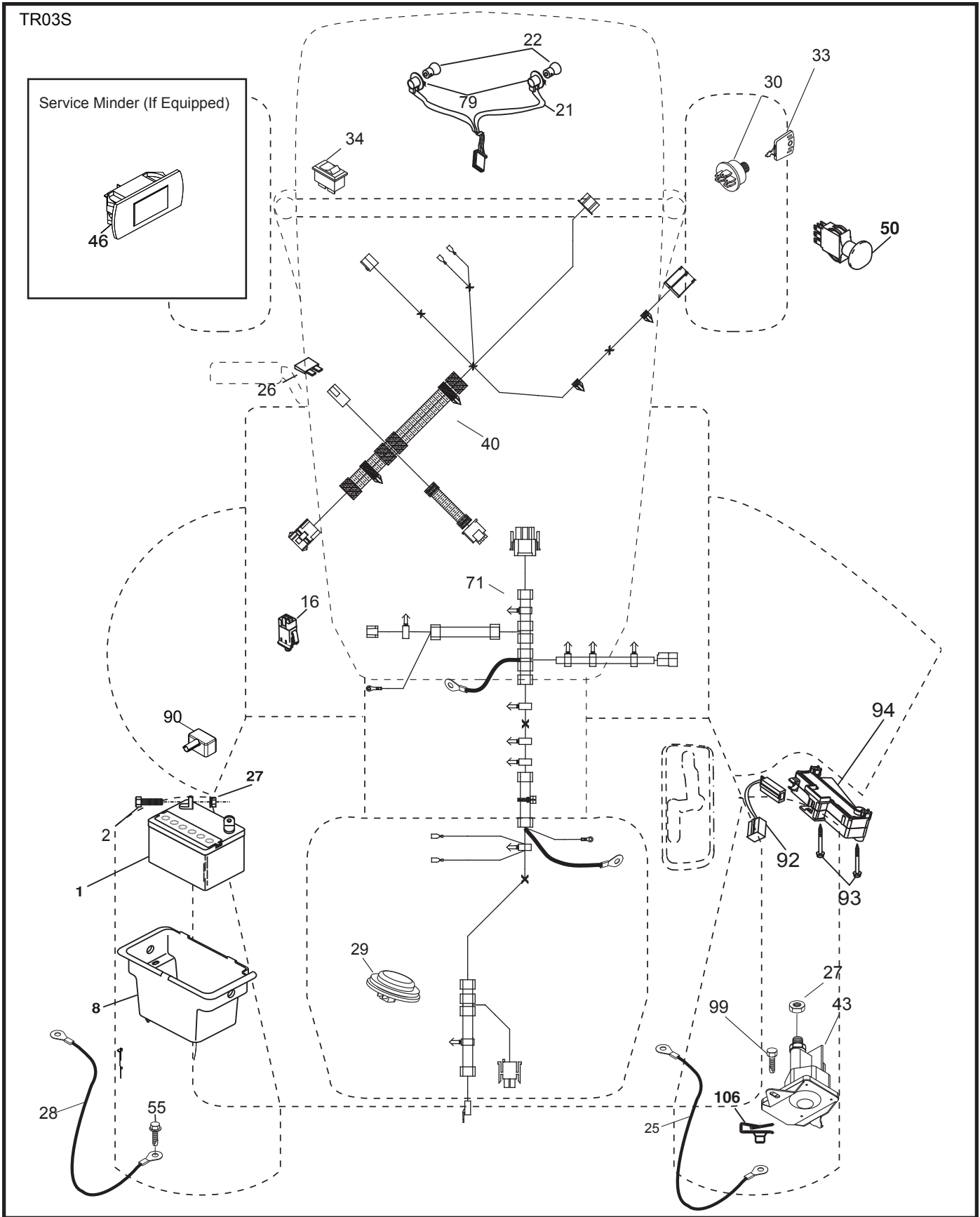

TRACTOR - - MODEL NUMBER 917.990370

ELECTRICAL

KEY NO.	PART NO.	DESCRIPTION
1	163465	Battery
2	74760412	Bolt Hex Hd 1/4-20 unc x 3/4
8	193228	Box Battery
16	176138	Switch Interlock Push-In
21	400252	Harness Socket Light w/4152J
22	4152J	Bulb Light
25	581498001	Cable Starter
26	175158	Fuse
27	73510400	Nut Keps Hex 1/4-20 unc
28	421686	Cable, Ground
29	401545	Switch, Seat
30	193350	Switch, Ign
33	411934	Key/Chain
34	110712X	Switch Light / Reset
40	401104	Harness Ign. Dash (if equipped with front solenoid)
--	581023201	Harness Ign. Dash (if equipped with rear solenoid)
43	192507	Solenoid
50	174651	Switch PTO
55	17060512	Screw Thdrol 5/16-18 x 3/4 TYTT
71	441544	Harness Ign. Chassis (if equipped with front solenoid)
--	501133701	Harness Ign. Chassis (if equipped with rear solenoid)
79	175242	Bulbholder Asm. Incan Descent
90	435395	Cover Terminal Battery
92	196615	Harness Pigtail
93	192540	Screw Plastite
94	191834	Module Reverse
99	17670412	Screw Hexwsh Thdrl 1/4-20 x 3/4
106	174814	Palnut 1/4 Lugs

NOTE: All component dimensions given in U.S. inches
1 inch = 25.4 mm

TRACTOR - - MODEL NUMBER 917.990370

CHASSIS ASSEMBLY

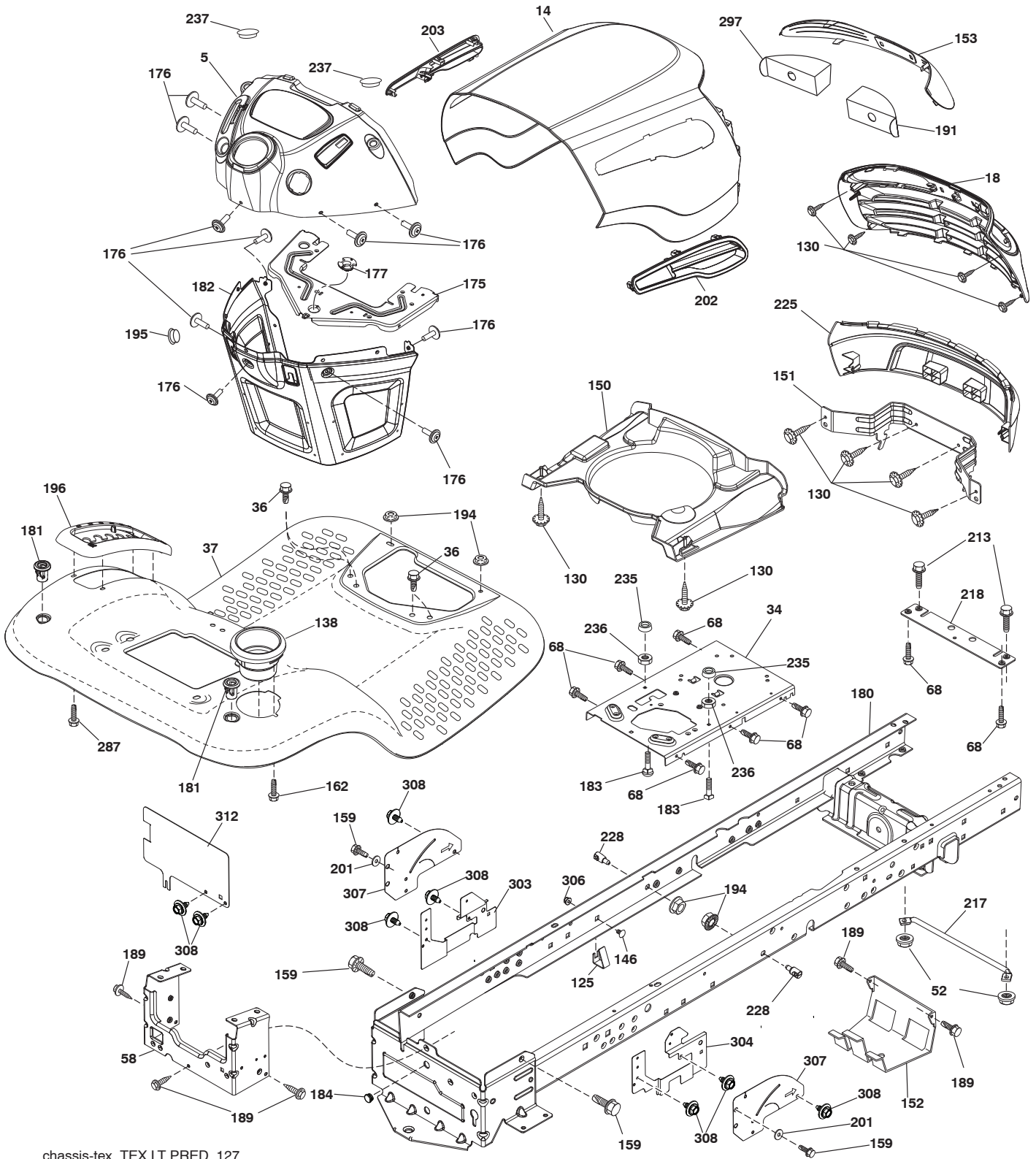

chassis-tex_TEX LT PRED_127

TRACTOR - - MODEL NUMBER 917.990370

CHASSIS ASSEMBLY

KEY NO.	PART NO.	DESCRIPTION
5	400800X428	Dash
14	198416X615	Hood
18	580427601	Grille
34	580910801	Plate Engine
36	17060512	Screw 5/16-18 x 3/4
37	414872X615	Fender
52	73680500	Nut Crown Lock 5/16-18
58	412280	Drawbar Upper
68	17490508	Screw Thdrol 5/16-18 x 1/2
125	581684801	Clip Fuel Line
130	416358	Screw #10 x 0.750
138	193224X428	Cupholder
146	581857901	Bolt
150	400267	Duct Heat Hood
151	187568	Bracket Pivot
152	199535	Shield Browning/Debris
153	400550X599	Lens
159	17000612	Screw Hexwsh Thdrol 3/8-16 x 3/4
162	142432	Screw Hex Wsh Hi-Lo 1/4 x 1/2
175	199472	Crossmember
176	400776	Screw 10-24 x 5/8 Wshd Qdrx
177	195228	Bushing Steering
180	415063	Chassis
181	193102X428	Bushing Mtg. Fender Crgo.
182	407176	Dash Lower
183	74520520	Bolt Full Thd 5/16-18 x 1-1/4
184	587554101	Plug
189	17000512	Screw 5/16-18 x 3/4
191	416502	Insert Reflective RH
194	73900500	Nut Lock Hex Flange 5/16-18
195	404951X428	Plug Dash Service Minder
196	414579	Console Asm. Deck Lift
201	19132016	Washer 13/32 x 1-1/4 x 16 Ga.
202	580427401	Vent Hood Side Panel RH
203	580427501	Vent Hood Side Panel LH
213	74760512	Bolt Hex HD 5/16-18 unc x 3/4
217	409167	Rod Pivot Hood
218	196395	X-Piece Hoodstop
225	400549X615	Bumper
228	195161	Stud Fastener
235	406129	Spacer Fender
236	73930500	Nut Center Lock 5/16-18
237	403704	Plug Mount Cargo
287	17600406	Screw 1/4-20 x 3/8
297	401827	Insert Reflective LH
303	587493402	Shield Lower LH
304	587865102	Shield Lower RH
306	73900600	Nut Lock
307	587494601	Shield Upper
308	171877	Bolt 5/16-18 unc x 3/4
312	587493002	Shield Drawbar

NOTE: All component dimensions given in U.S. inches
1 inch = 25.4 mm

TRACTOR - - MODEL NUMBER 917.990370

GROUND DRIVE

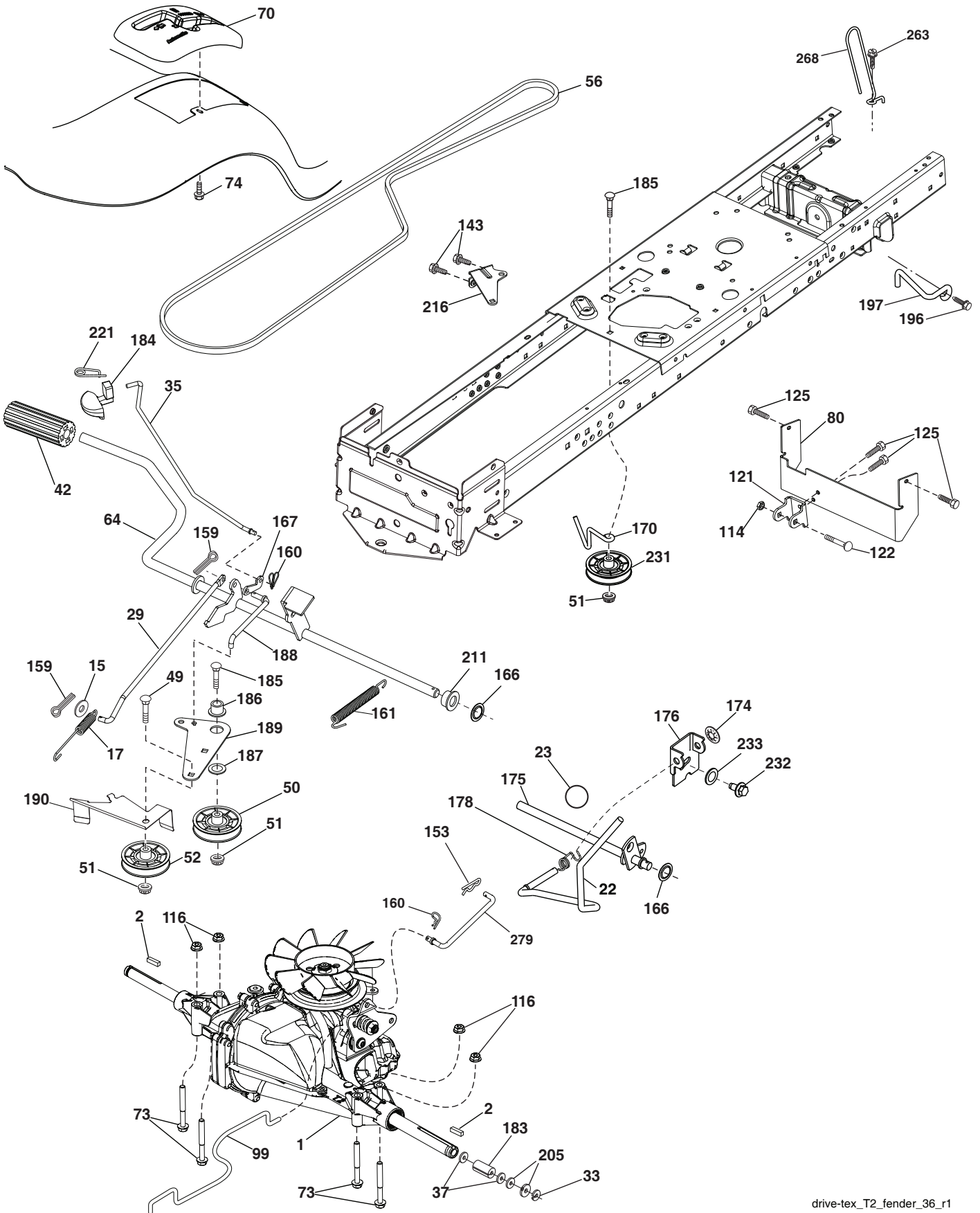

drive-tex_T2_fender_36_r1

TRACTOR - - MODEL NUMBER 917.990370

GROUND DRIVE

KEY NO.	PART NO.	DESCRIPTION	KEY NO.	PART NO.	DESCRIPTION
1	-----	Transaxle, T2-CDBE-5X1A-18C1 (581115602)(Order parts from transaxle manufacturer.)	166	429164	Nut Push .625
2	123583X	Key Square	167	405257	Latch Brake Parking
15	19131316	Washer 13/32 x 13/16 x 16 Ga.	170	413430	Keeper Belt Centerspan
17	197296	Spring, Brake	174	197289	Nut Push
22	197660	Rod Shift	175	408539	Shaft Asm Shift
23	140845	Knob	176	196214	Arm Clevis Rod Shift
29	581506401	Rod, Brake	178	197456	Spring Shift
33	12000001	Ring E	183	156972	Spacer Axle
35	401031	Rod, Brake, Park	184	199996X428	Handle Parking Brake
37	121749X	Washer 25/32 x 1-1/4 x 16	185	72110622	Bolt
42	8883R	Cover, Foot Pedal	186	194321	Spacer Retainer
49	72110614	Bolt	187	19133210	Washer
50	194327	Pulley Idler Flat	188	194323	Link Clutch Ground Drive
51	73900600	Lock Nut 3/8-16	189	194317	Bellcrank Ground Drive
52	194326	Idler V-Groove	190	194318	Keeper Bellcrank Ground Drive
56	581270501	V-Belt, Drive	196	17000616	Screw 3/8-16 x 1
64	196200	Shaft Asm. Pedal Brake Control	197	585658601	Link Clutch Anti-Rotation
70	193220X428	Console	205	121748X	Washer 25/32 x 1-5/8 x 16 Ga.
73	74490544	Bolt Hex 5/16-18 x 2-1/2 G5	211	196212	Bushing Shaft
74	142432	Screw 1/4 x 1/2	216	196131	Bracket Pulley Idler
80	581550701	Strap Torque	221	403187	Retainer Spring Clip Handle
99	408418	Rod Spring Bypass	231	407287	Idler V-Groove
114	73800500	Nut Lock	232	74780716	Bolt 7/16-14 x 1 Gr 5
116	73900500	Nut Lock Hex Flange 5/16-18	233	405296	Washer Serrated
121	175611	Bracket Strap Torque	263	17000612	Screw hexwsh Thdr 3/8-16 x 3/4
122	72010520	Bolt 5/16-18 x 2.50	268	182402	Guard Muffler
125	17000512	Screw 5/16-18 x 3/4	279	424155	Link Shift
143	17490508	Screw THDROL 5/16-18			
153	4497H	Retainer Spring 1"			
159	76020412	Pin Cotter 1/8 x 3/4			
160	169484	Retainer Clip			
161	105709X	Spring, Return, Clutch			

NOTE: All component dimensions given in U.S. inches
1 inch = 25.4 mm

TRACTOR - - MODEL NUMBER 917.990370

ENGINE

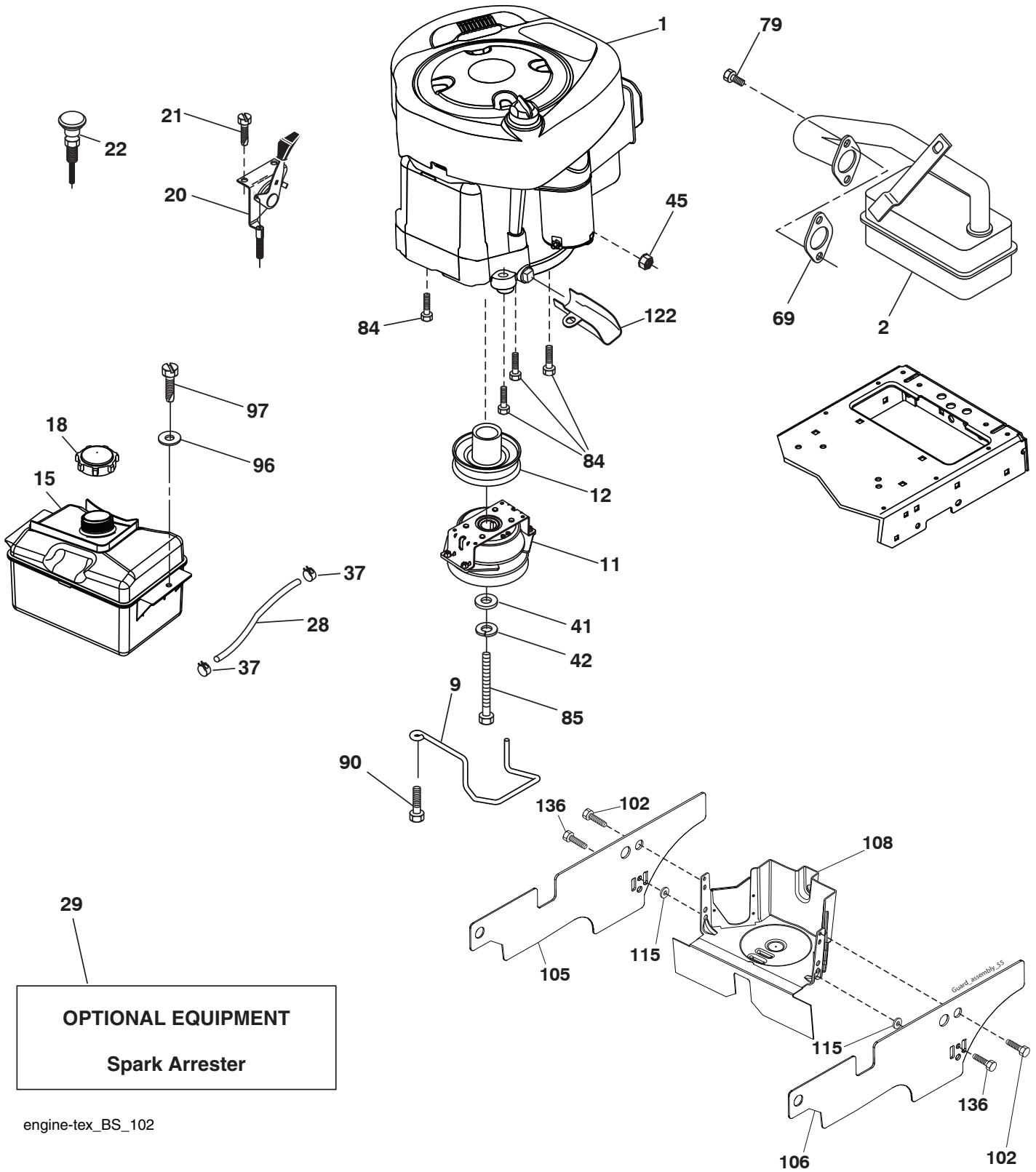

engine-tex_BS_102

TRACTOR - - MODEL NUMBER 917.990370

ENGINE

KEY NO.	PART NO.	DESCRIPTION
1	- - - -	Engine B&S Model No. 31R977-00011-B1(585689201)(See engine breakdown.)
2	137352	Muffler
9	584908001	Keeper Belt Engine
11	587241501	Clutch
12	405097	Pulley Engine
15	581289901	Tank Fuel 1.50
18	430220	Cap Fuel
20	176636X428	Control Throttle/Choke
21	416358	Screw #10 x 0.750
22	187771X428	Control Choke
28	137040	Fuel Line
29	137180	Spark Arrester Kit
37	123487X	Clamp Hose
41	126197X	Washer 1-1/2 x 15/32 x .250
42	10040700	Washer Lock 7/16
45	73510400	Nut Keps Hex 1/4-20 unc
69	165291	Gasket
79	192334	Screw Socket Hd 5/16-18 x .75
84	17060620	Screw 3/8-16 x 1-1/4
85	581332804	Bolt 7/16-20 x 3.5 Gr 524 HR
90	17000616	Screw 3/8-16 x 1.0
96	19091416	Washer 9/32 x 7/8 x 16 Ga.
97	17670412	Screw 1/4-20 x 3/4
102	17000512	Screw 5/16-18 x 3/4
105	501267202	Shield Side LH
106	501268202	Shield Side RH
108	421794	Cover Asm Engine Pulley
115	423062	Palnut 1/4
122	421922	Extension Drain Oil
136	137729	Screw Thdrol 1/4-20 x 5/8

NOTE: All component dimensions given in U.S. inches
1 inch = 25.4 mm

Engine Power Rating Information

The gross power rating for individual gas engine models is labeled in accordance with SAE (Society of Automotive Engineers) code J1940 (Small Engine Power & Torque Rating Procedure), and rating performance has been obtained and corrected in accordance with SAE J1995 (Revision 2002-05). Torque values are derived at 3060 RPM; horsepower values are derived at 3600 RPM. Actual gross engine power will be lower and is affected by, among other things, ambient operating conditions and engine-to-engine variability. Given both the wide array of products on which engines are placed and the variety of environmental issues applicable to operating the equipment, the gas engine will not develop the rated gross power when used in a given piece of power equipment (actual "on-site" or net power). This difference is due to a variety of factors including, but not limited to, accessories (air cleaner, exhaust, charging, cooling, carburetor, fuel pump, etc.), application limitations, ambient operating conditions (temperature, humidity, altitude), and engine-to-engine variability. Due to manufacturing and capacity limitations, Briggs & Stratton may substitute an engine of higher rated power for this Series engine.

TRACTOR - - MODEL NUMBER 917.990370

STEERING ASSEMBLY

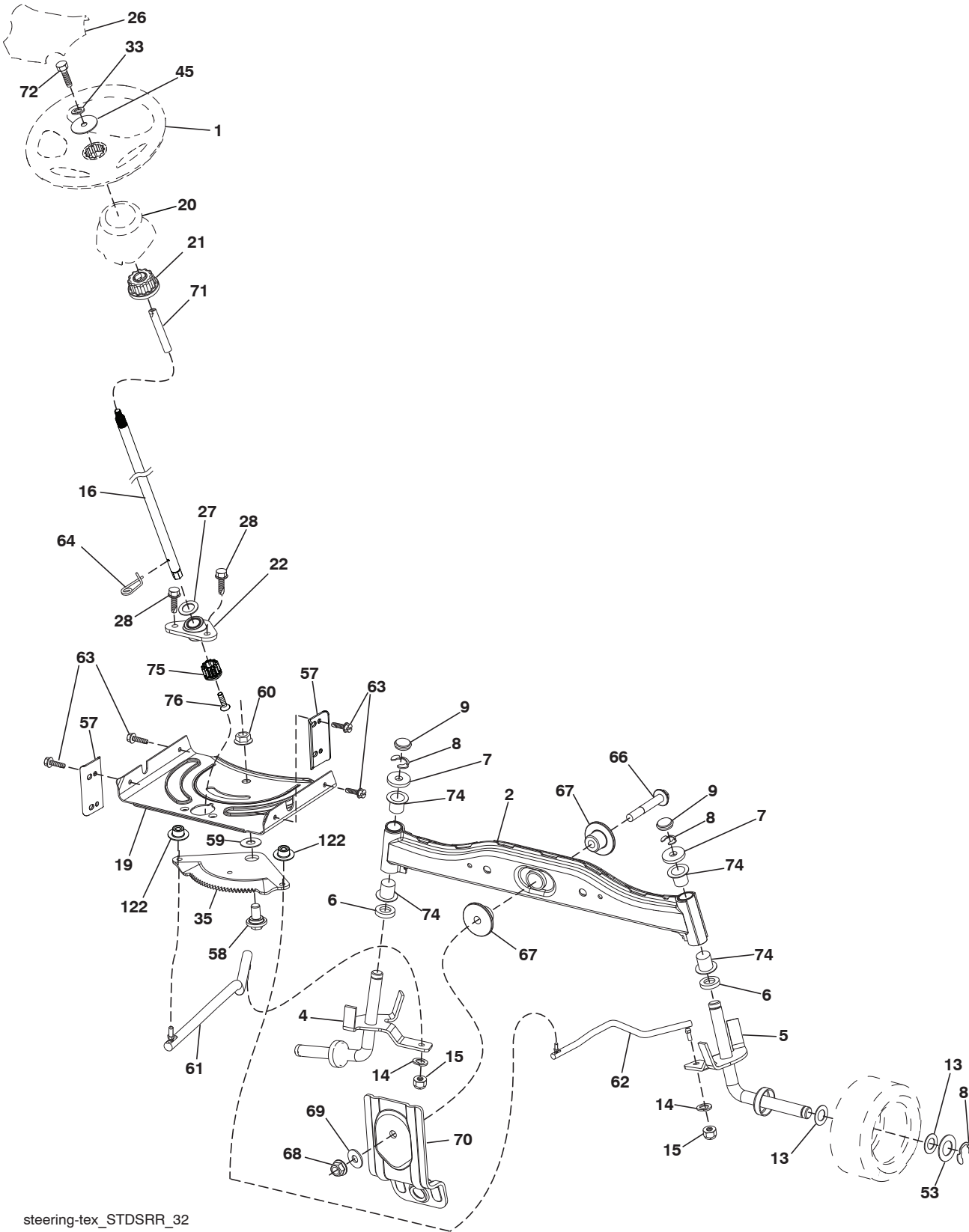

steering-tex_STDSRR_32

TRACTOR - - MODEL NUMBER 917.990370

STEERING ASSEMBLY

KEY NO.	PART NO.	DESCRIPTION
1	414851X428	Wheel, Steering
2	418168	Axle Asm., Front
4	403087	Spindle Asm., LH
5	403088	Spindle Asm., RH
6	6266H	Washer Thrust 0.75 x 1.23
7	121748X	Washer 25/32 x 1-5/8 x 16 Ga.
8	12000029	Ring, Clip #T5304-75
9	121232X	Cap, Spindle
13	121749X	Washer 25/32 x 1-1/4 x 16 Ga.
14	10040600	Washer Lock 3/8
15	73540600	Nut, Crown Lock 3/8-24 unf
16	585869202	Shaft Steering
19	194729	Plate Steering
20	400803X428	Boot, Steering
21	186737	Adapter, Wheel Steering
22	585029802	Steering Supt. Lower
26	414852X428	Insert, Wheel Steering
27	19211616	Washer 21/32 x 1 x 16 Ga.
28	17000612	Screw 3/8-16 x 3/4
33	10040500	Washer Lock 5/16
35	194732	Gear, Sector Plate
45	19113812	Washer 11/32 x 2-3/8 x 12 Ga.
53	188967	Washer Hardened .793x1.637x.060
57	407465	Bracket Upstop
58	194747	Bolt Shoulder Sector Pivot CFM
59	194748	Washer Thrust Sector Steering
60	73971000	Nut Flange Lock 5/8-11
61	194740	Draglink, LH
62	194741	Draglink, RH
63	17000512	Screw 5/16-18 x 3/4
64	199849	Retainer Clip Spring Steering
66	71020748	Bolt Hex Fghd 7/16-14 x 3 Serr
67	194737	Bushing PM Front Axle
68	73900700	Nut Lock Flange 7/16-14 Gr. 5
69	199162	Washer 1.5 x .505 x .118
70	585338801	Bracket Deck Susp. Front
71	190752	Shaft Ext. Steering
72	428982	Bolt Fin Hex 5/16-18 x 4
74	3366R	Bearing
75	580683701	Pinion
76	580683601	Screw Head Socket
122	444962	Cap Gear Sector

NOTE: All component dimensions give in U.S. inches
1 inch = 25.4 mm

TRACTOR - - MODEL NUMBER 917.990370

MOWER DECK

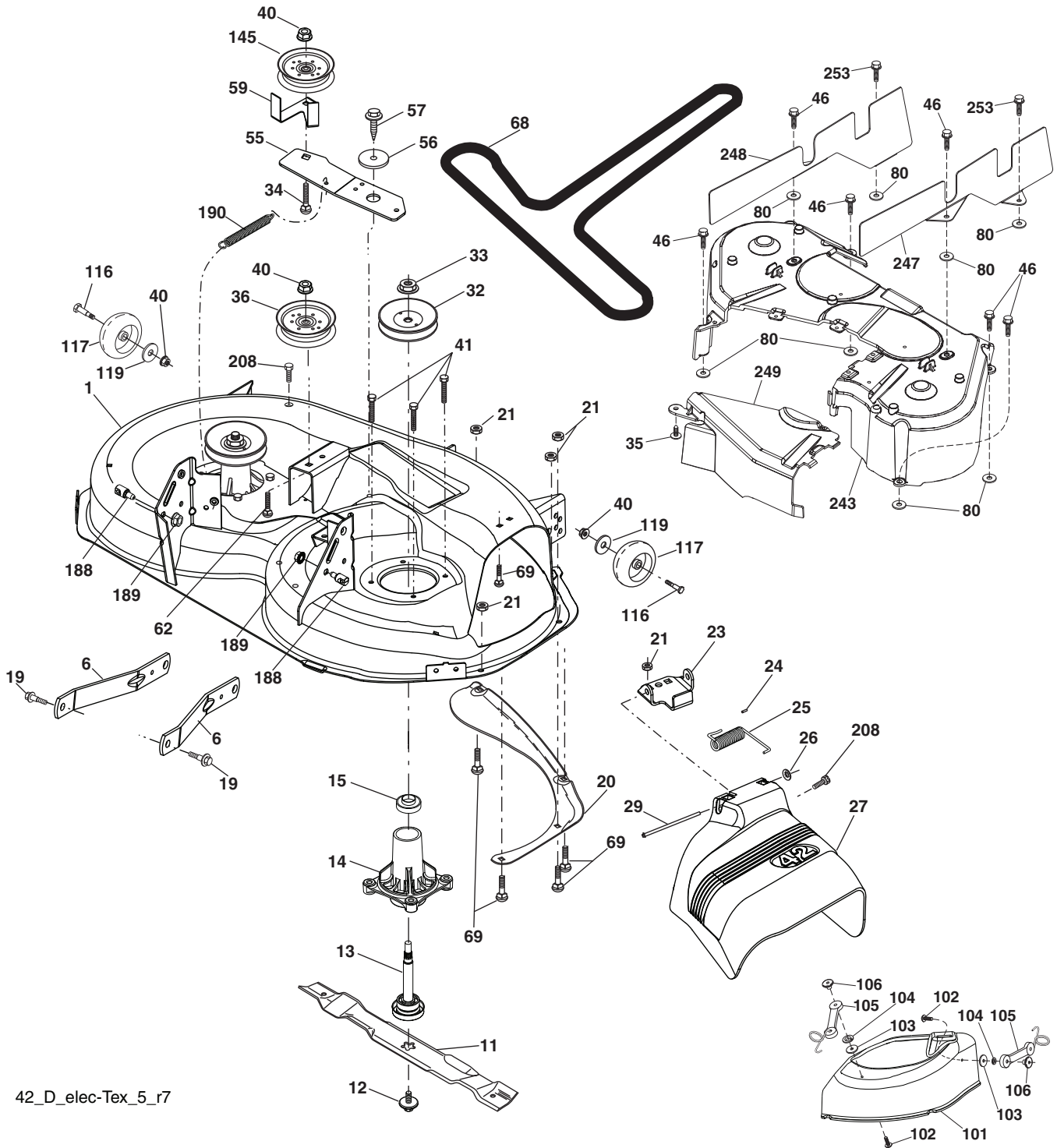

42_D_elec-TeX_5_r7

TRACTOR - - MODEL NUMBER 917.990370

MOWER DECK

KEY NO.	PART NO.	DESCRIPTION	KEY NO.	PART NO.	DESCRIPTION
1	196495	Mower Housing	62	72110616	Bolt Rdhd Sqnk 3/8-16 unc x 2
6	195186	Arm Suspension	68	144959	V-Belt
8	193003	Bolt/Washer Asm 7/16-20 unf	69	72140505	Bolt Rdhd Sqnk 5/16-18 x 5/8
11	424752	Blade 3 in 1	80	423062	Palnut 1/4
--	422719	Blade 3 in 1 Premium	101	193107	Cover Mulching
--	134149	Blade Mulching Standard	102	71081010	Screw Pan Hd 10-24 x 5/8
--	139775	Blade Mulching Premium	103	19061216	Washer #10
--	138971	Blade, 42" Hi-Lift (For bagging or discharge)	104	10071000	Washer Lock #10
13	192872	Shaft Assembly, Mandrel	105	160793	Latch Asm.
14	187281	Housing, Mandrel	106	2029J	Nut Weld
15	110485X	Bearing, Ball, Mandrel	116	4898H	Bolt Shld. "A" 2.41 "B"1.66
19	196539	Bolt, Shoulder	117	188606	Wheel Gage
20	159770	Baffle, Vortex	119	19121414	Washer 3/8 x 7/8 x 14 Ga.
21	73680500	Nut, Crownlock 5/16-18 unc	145	193197	Pulley, Idler, Flat
23	192557	Bracket, Deflector	188	195161	Stud Fastener
24	105304X	Cap, Sleeve	189	73900500	Nut Lock Hex Flange
25	197026	Spring, Torsion, Deflector	190	197251	Spring Mower Drive
26	110452X	Nut, Push	208	17670608	Screw 3/8-16 x 1/2
27	406520X428	Shield, Deflector	243	432394	Cover Asm Deck
29	131491	Rod, Hinge	247	430261	Shield Deck RH
30	173984	Screw Thdrol Rolling Wsh Hd	248	430260	Shield Deck LH
31	187690	Washer, Spacer	249	406514	Cover Cable Clutch
32	153535	Pulley, Mandrel	253	427350	Rivet Tuflock 25 x .24
33	400234	Nut, Toplock, Flanged	--	192870	Mandrel Assembly (Includes housing (key# 14), shaft assembly (key# 13), bearing (key# 15) and nut (key# 33)only - pulley/washer and blade bolt/washers not included)
34	72110612	Bolt Carr Sh. 3/8-16 x 1-1/2 Gr. 5	--	588115501	Replacement Mower, Complete
35	133835	Fastner Christmas Tree			
36	197379	Pulley Idler			
40	73900600	Nut, Lock Flg. 3/8-16 unc			
41	584953901	Bolt Hex Wsh Hd 3/8-16 x 1.19			
46	137729	Screw Thdrol 1/4-20 x 5/8			
55	437110	Arm, Idler			
56	199092	Spacer, Retainer			
57	17000616	Screw Hexwsh Thd 3/8-16 x 1			
59	141043	Guard, Tuv Idler (94)			

NOTE: All component dimensions given in U.S. inches
1 inch = 25.4 mm

TRACTOR - - MODEL NUMBER 917.990370

LIFT ASSEMBLY

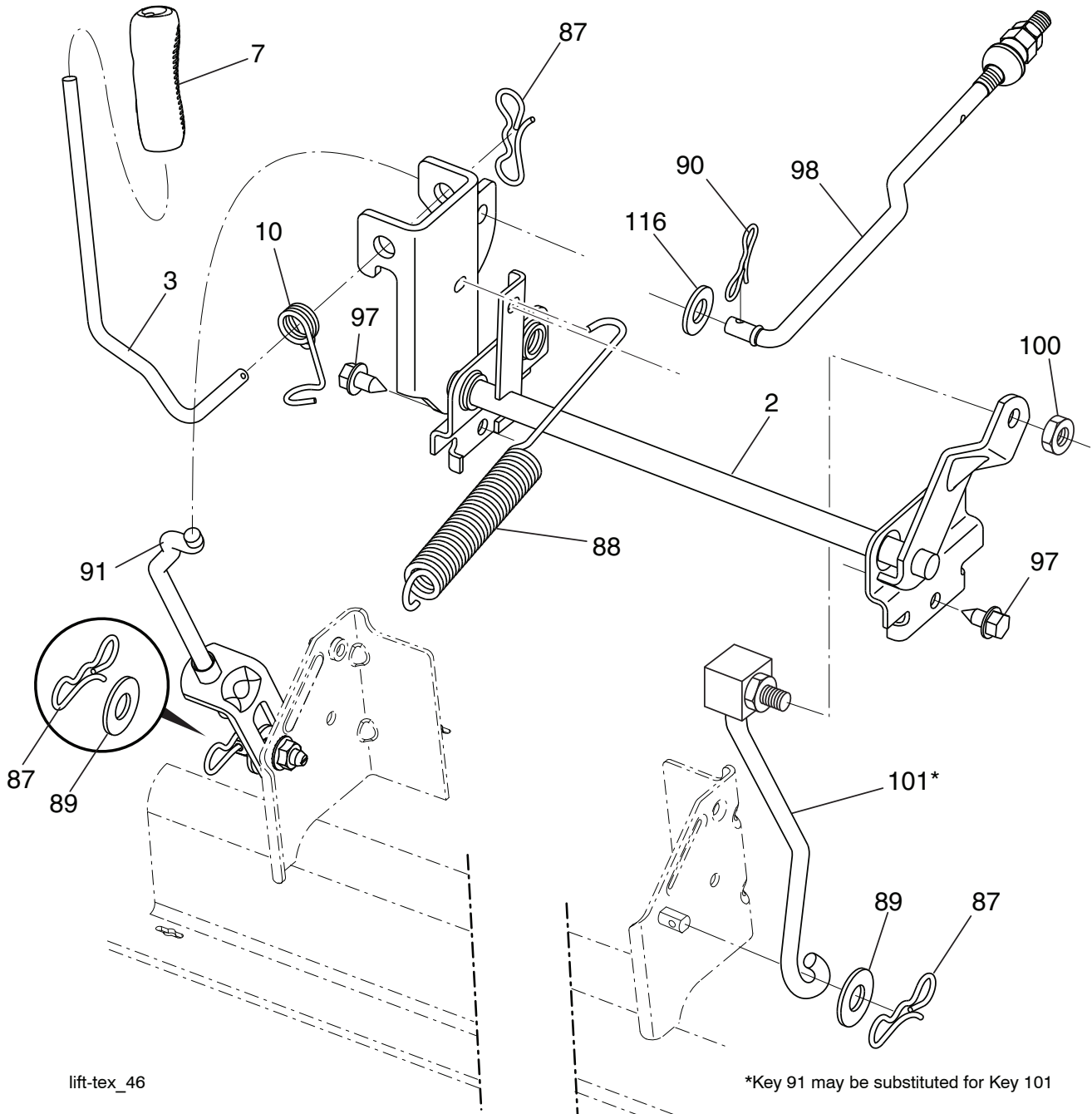

lift-tex_46

*Key 91 may be substituted for Key 101

KEY NO.	PART NO.	DESCRIPTION
2	422027	Shaft Asm., Lift
3	195231	Lever Asm., Lift RH
7	445060X428	Grip, Lever
10	196314	Spring Torsion
87	194209	Pin Cotter 7/16 Bow Tie Lock
88	410710	Spring Lift Assist
89	19191912	Washer Clear Zinc
90	194208	Pin Cotter 5/16 Bow Tie Lock
91	197984	Link Lift Susp Mower Rear

KEY NO.	PART NO.	DESCRIPTION
97	17000612	Screw 3/8-16 x .75
98	581506901	Link Lift Susp. Front Mower
100	73930600	Nut Centerlock 3/8-16 unc
101	581506501	Link Asm Lift Fixed
116	19151516	Washer 15/32 x 15/16 x 16 Ga.

NOTE: All component dimensions give in U.S. inches
1 inch = 25.4 mm

TRACTOR - - MODEL NUMBER 917.990370

SEAT ASSEMBLY

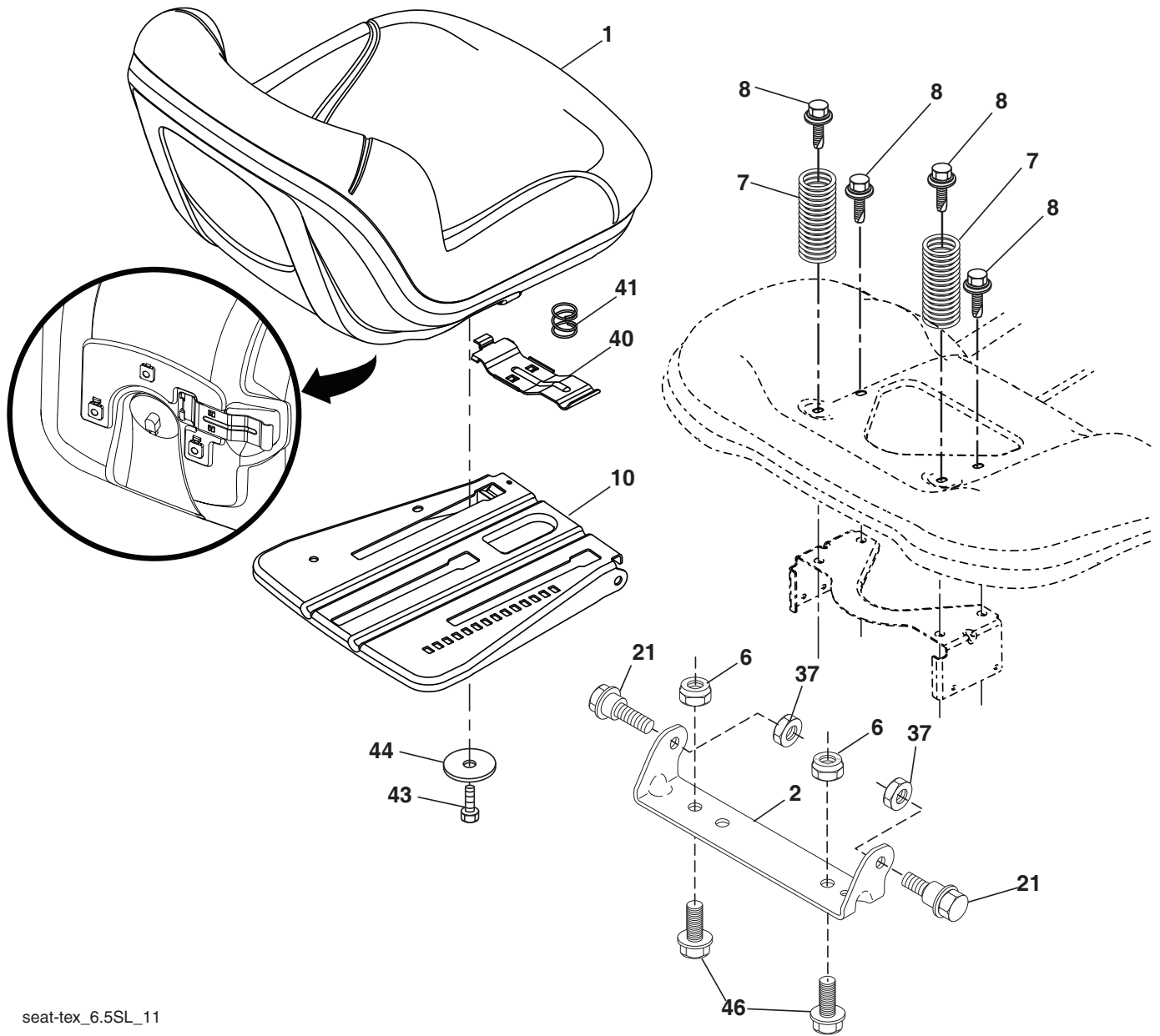

seat-tex_6.5SL_11

KEY NO.	PART NO.	DESCRIPTION
1	586507601	Seat
2	180166	Bracket Pivot Fender
6	73800600	Nut, Lock w/lns. 3/8-16 unc
7	587663301	Spring, Seat Cprsn
8	171877	Bolt 5/16-18 unc x 3/4 w/Sems
10	196977	Pan, Seat
21	587907801	Bolt, Shoulder 5/16-18 x 5/8
37	73800500	Nut, Lock 5/16-18 unc
40	197661	Handle Slide

KEY NO.	PART NO.	DESCRIPTION
41	198200	Spring Latch
43	74760612	Bolt 3/8-16 unc x 3/4
44	19133812	Washer 13/32 x 2 3/8 x 12 Ga.
46	588090401	Bolt 3/8-16 x 1, 1.25 OD Wshr.

NOTE: All component dimensions give in U.S. inches
1 inch = 25.4 mm

TRACTOR - - MODEL NUMBER 917.990370

DECALS

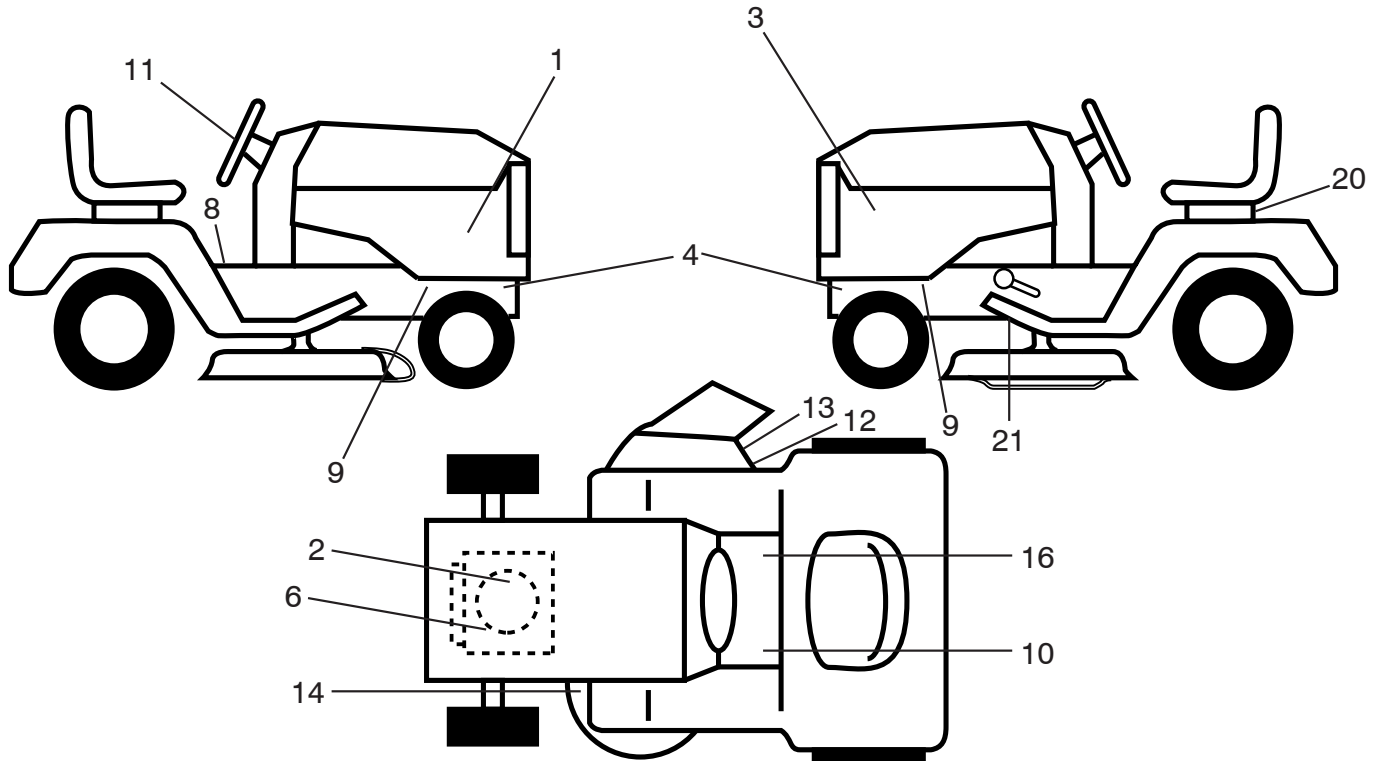

KEY NO.	PART NO.	DESCRIPTION
1	586207301	Decal Side Panel Logo RH
2	442546	Decal Eng. H.P.
3	586207302	Decal Side Panel Logo LH
4	581579801	Decal Warning Service/Fire
6	581579701	Decal Warning Engine
8	581578101	Decal Fender Warn
9	581579601	Decal Hot Muffler
10	581724001	Decal Brake/Clutch
11	439525	Decal Ins Strg Whl
12	581579201	Decal Warning
13	584904601	Decal Cutfinger CE
14	581580001	Decal V-Belt Schematic

KEY NO.	PART NO.	DESCRIPTION
16	581578001	Decal Saddle Brake Parking
20	145005	Decal Bat Dan/Psn
21	421534	Decal V-Belt Sch.
--	581724801	Decal Bypass Fender
--	193226X428	Pad Footrest LH
--	193227X428	Pad Footrest RH
--	581724601	Decal Drawbar Load Limit
--	588082140	Manual Oper. (Euro)
--	588082150	Manual Oper. (Scan)
--	588082120	Manual Oper. (E-Bloc)
--	588082130	Manual Oper. (Baltic)
--	588082126	Manual Parts (English)

WHEELS & TIRES

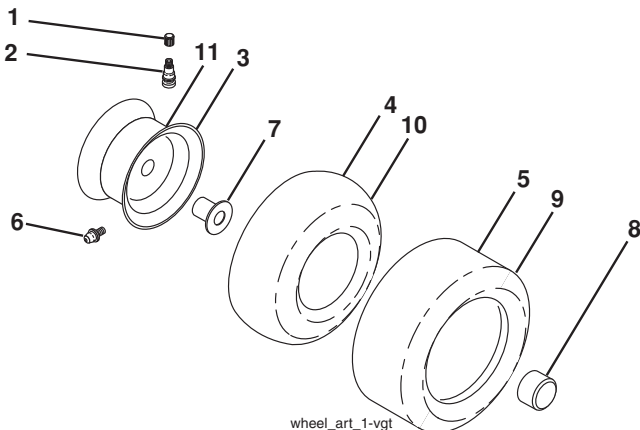

KEY NO.	PART NO.	DESCRIPTION
1	59192	Cap Valve Tire
2	65139	Stem Valve
3	106732X613	Rim Asm 6" Front
4	59904	Tube Front (Service Item Only)
5	106222X	Tire Front 15 x 6-6
6	278H	Fitting Grease (Front Wheel Only)
7	9040H	Bearing Flange (Front Wheel Only)
8	104757X428	Cap Axle Blk 1 50 x 1 00
9	138468	Tire Rear 20 x 8-8
10	7152J	Tube Rear (Service Item Only)
11	106108X613	Rim Asm 8" Rear Service
--	144334	Sealant, Tire (10 oz. Tube)

NOTE: All component dimensions give in U.S. inches
1 inch = 25.4 mm

SERVICE NOTES

TRACTOR - - MODEL NUMBER 917.990370
 HYDRO GEAR TRANSAXLE - MODEL NO. T2-CDBE-5X1A-18C1

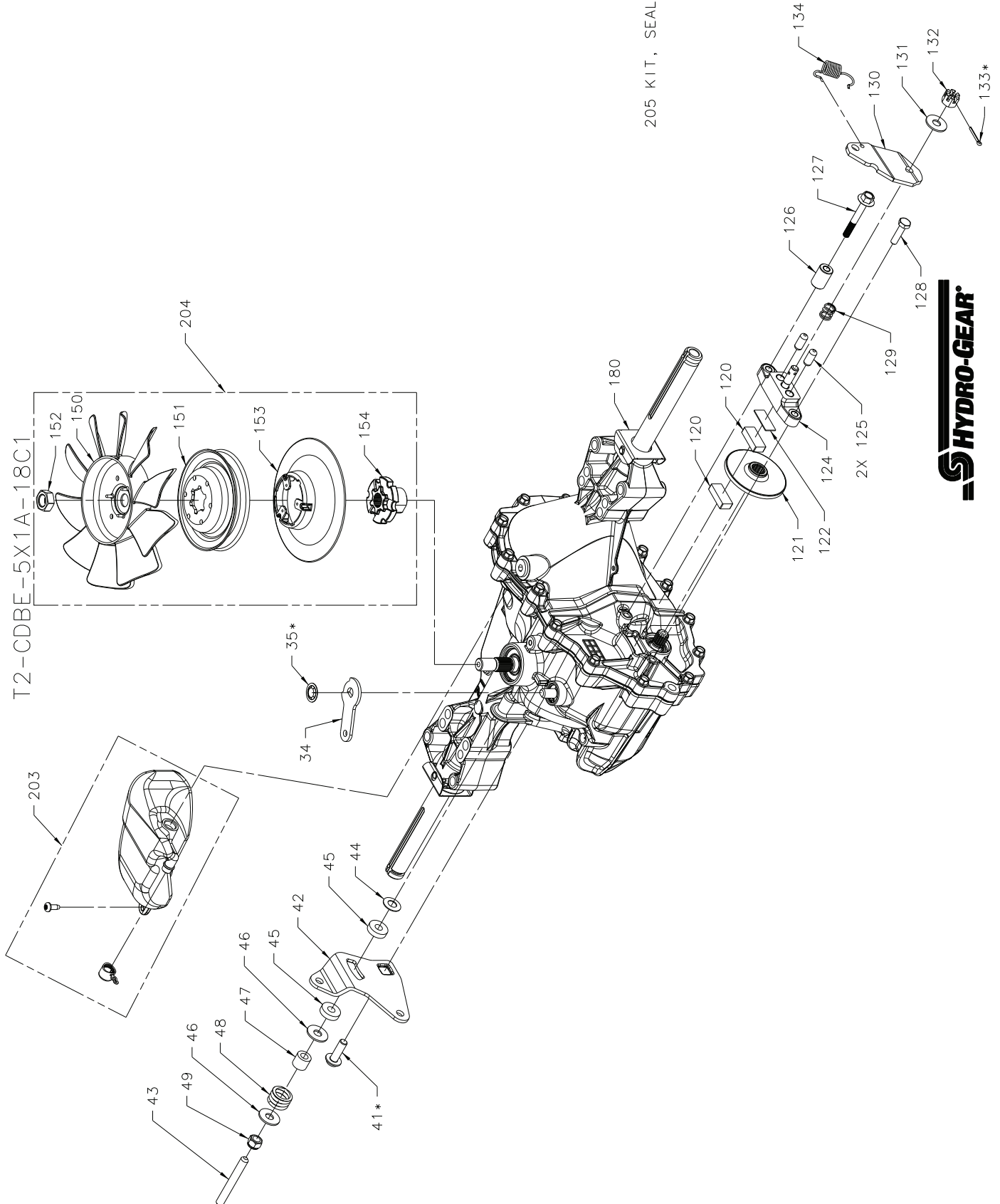

TRACTOR - - MODEL NUMBER 917.990370
HYDRO GEAR TRANSAXLE - MODEL NO. T2-CDBE-5X1A-18C1

KEY NO.	PART NO.	DESCRIPTION
34	584280701	Arm Bypass
35	584281001	Ring, Ret .375 Ext
41	584281201	Screw 5/16-18X1
42	584289801	Arm Control
43	584281301	Screw Set 5/16-24X2.50
44	584283301	Washer Belleville
45	584283101	Washer Plastic.32X.80X.21
46	584283001	Washer.34X.88X.06
47	584282801	Spacer .32X.59X.50
48	584282701	Spring Helical Comp
49	584289501	Nut,Hex 5/16-24 Nylon Insert
120	584282601	Puck.Brake
121	584282501	Rotor.Brake
122	584289601	Plate.Puck
124	584289701	Yoke.Brake
125	584287501	Pin.Brake.31X.73 Plated
126	584282401	Spacer.26X.57X.87
127	584281401	Screw 1/4-20X2.0 W/Patch
128	584281501	Screw 1/4-20X1 Patch
129	584282201	Spring, Comp Brake Anti Drag
130	584282301	Arm.Brake
131	584287401	Washer .34X.88X.06
132	584281701	Nut.Castle 5/16-24 Pl
133	584286601	Pin.Cotter 3/32X3/4
134	584281901	Spring Brake Arm Bias
150	584282001	Fan 7", 10 Blade
151	584286101	Pulley 4.0
152	584282101	Nut,Hex Ja 1/2-20 W Patch
153	584287201	Flange Pulley 4.895
154	584287301	Hub Pulley
180	584281601	Spring,Clip Housing Thrust
203	584285201	Kit,E-Tank
204	584285002	Kit,Fan & Pulley
205	584285001	Kit, Seal

NOTE: All component dimensions give in U.S. inches
1 inch = 25.4 mm

TRACTOR - - MODEL NUMBER 917.990370

BRIGGS & STRATTON ENGINE-MODEL NUMBER 31R977, TYPE NUMBER 0011-B1

48 SHORT BLOCK

1036 EMISSIONS LABEL

1058 OPERATOR'S MANUAL

1329 REPLACEMENT ENGINE

1330 REPAIR MANUAL

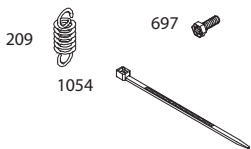
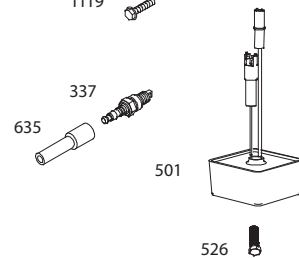
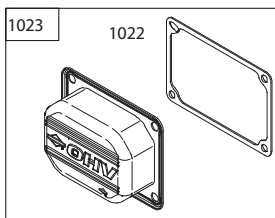
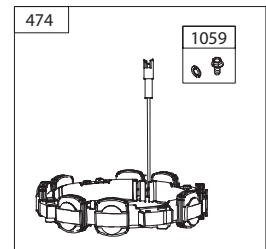
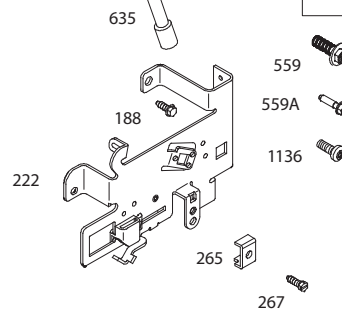
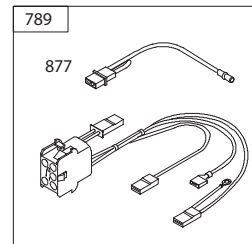
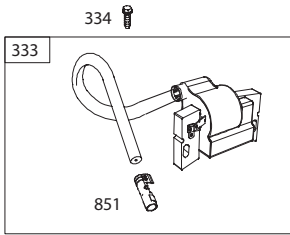
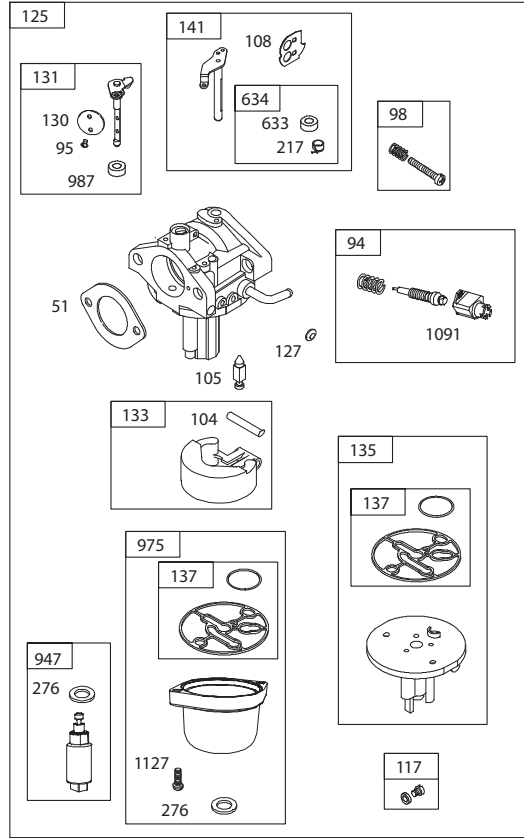
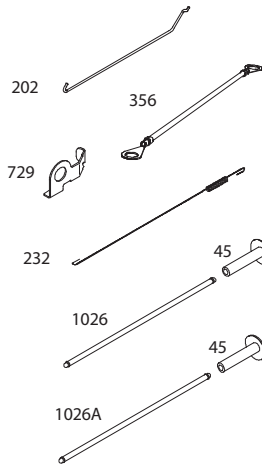
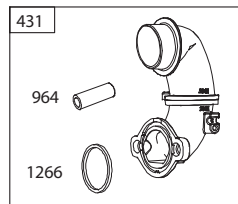
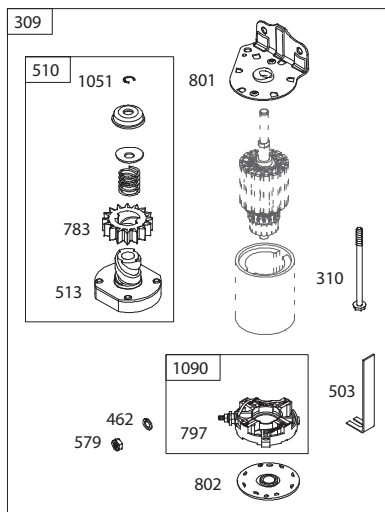
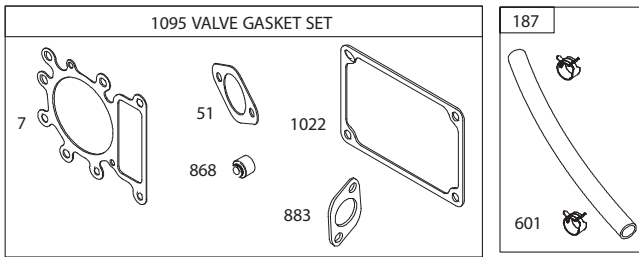
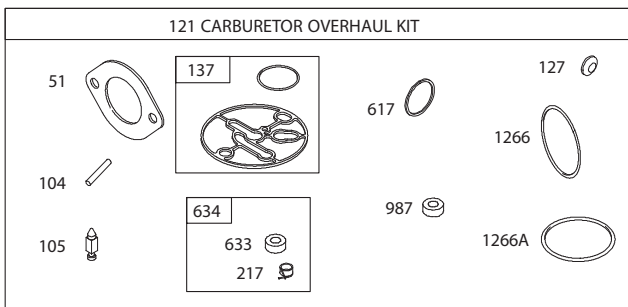
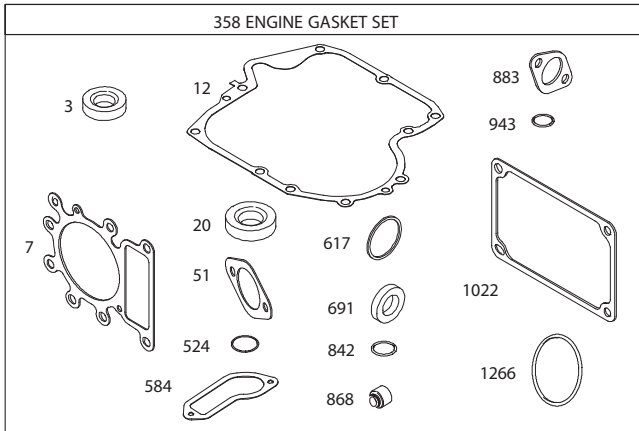

TRACTOR - - MODEL NUMBER 917.990370
BRIGGS & STRATTON ENGINE-MODEL NUMBER 31R977, TYPE NUMBER 0011-B1

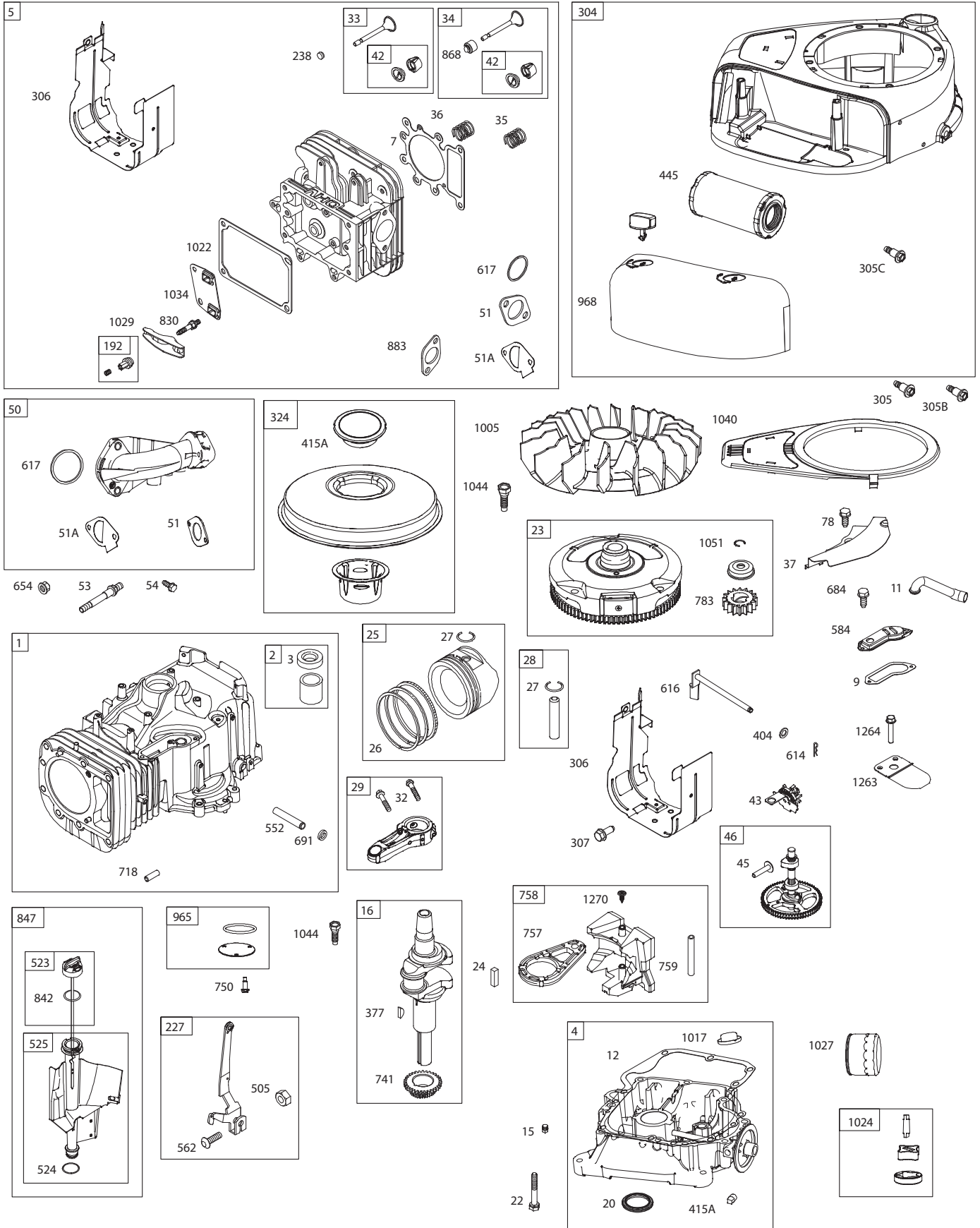

TRACTOR - - MODEL NUMBER 917.990370

BRIGGS & STRATTON ENGINE-MODEL NUMBER 31R977, TYPE NUMBER 0011-B1

KEY NO.	PART NO.	DESCRIPTION	KEY NO.	PART NO.	DESCRIPTION
1	796010	Cylinder Assembly	133	694914	Float-Carburetor
2	797673	Bushing/Seal Kit (Magneto Side)	135	698780	Tube-Fuel Transfer
3	391086s	Seal-Oil (Magneto Side)	137	698781	Gasket-Float Bowl
4	592849	Sump-Engine	141	592937	Kit-Choke Shaft
5	796026	Head-Cylinder	187	791766	Line-Fuel (Cut to Required Length)
7	796584	Gasket-Cylinder Head	188	691693	Screw (Control Bracket)
9	697109	Gasket-Breather	192	691986	Adjuster-Rocker Arm
11	794683	Tube-Breather	202	691841	Link-Mechanical Governor
12	697110	Gasket-Crankcase	209	796260	Spring-Governor (Green)
13	592244	Screw (Cylinder Head)	217	695409	Spring-Choke Return
15	690946	Plug-Oil Drain	222	694042	Bracket-Control
16	591763	Crankshaft	227	691374	Lever-Governor Control
20	795387	Seal-Oil (PTO Side)	232	691842	Spring-Governor Link
22	692125	Screw (Crankcase Cover/Sump)	238	691843	Cap-Valve
23	591758	Flywheel	240	394358s	Filter-Fuel
24	591757	Key-Flywheel (Steel)	265	691024	Clamp-Casing
25	796172	Piston Assembly (Standard)	267	794904	Screw (Casing Clamp)
	796173	Piston Assembly (.020" Over size)	276	695410	Washer-Sealing
26	791936	Ring Set (Standard)	304	591642	Blower Housing
	792649	Ring Set (.020" Oversize)	305	697102	Screw (Blower Housing)
27	698469	Lock-Piston Pin	305B	795891	(1/4-20x1.21) Screw (Blower Housing to Intake Elbow) (#10-16x.43)
28	796007	Pin-Piston	305C	799370	Screw (Blower Housing)
29	794571	Rod-Connecting			(1/4-20x.90)
32	791118	Screw (Connecting Rod)	306	592777	Shield-Cylinder
33	792868	Valve-Exhaust	307	691693	Screw (Cylinder Shield)
34	791935	Valve-Intake	309	693551	Motor-Starter
35	691279	Spring-Valve (Intake)	310	690323	Screw (Starter Motor)
36	691279	Spring-Valve (Exhaust)	324	796308	Screen/Cup Assembly
37	697352	Guard-Flywheel	356	697089	Stop-Wire
42	499586	Keeper-Valve	333	799650	Armature-Magneto
43	691968	Slinger-Governor/Oil	334	691061	Screw (Magneto Armature)
45	690564	Tappet-Valve	337	691043	Plug-Spark
46	793880	Gear-Cam	358	796187	Gasket Set-Engine
48	N/A	Short Block (Not Available at This Printing)	377	691639	Key-Woodruff
50	592842	Manifold-Intake	404	691691	Washer (Governor Crank)
51	692137	Gasket-Intake	415	794129	Plug (Cover/Retainer)
51A	796081	Gasket-Intake	415A	794903	Plug
53	591260	Stud (Carburetor)	431	797901	Elbow-Intake
54	691148	Screw (Intake Manifold)	445	591334	Filter-Air Cleaner Cartridge
78	691693	Screw (Flywheel Guard)	462	691261	Washer (Starter Cable)
94	793610	Kit-Idle Mixture	474	592829	Alternator
95	690718	Screw (Throttle Valve)	501	794360	Regulator
98	695408	Kit-Idle Speed	503	691532	Strap-Starter
104	694918	Pin-Float Hinge	505	691251	Nut (Governor Control Lever)
105	696136	Valve-Float Needle	510	693699	Drive-Starter
108	695419	Valve-Choke	513	692024	Clutch-Drive
117	699733	Jet-Main (Standard)	523	699908	Dipstick
118	843099	Jet-Main (High Altitude) (5000/9000 Feet)	524	691032	Seal-Dipstick Tube
121	796184	Kit-Carburetor Overhaul	525	697184	Tube-Dipstick
125	591734	Carburetor	526	697088	Screw (Regulator)
127	690727	Plug-Welch	552	697144	Bushing-Governor Crank
130	792747	Valve-Throttle	559	693675	Screw (Remote Choke Stop)
131	792765	Kit-Throttle Shaft			(6 Lobe)

TRACTOR - - MODEL NUMBER 917.990370
BRIGGS & STRATTON ENGINE-MODEL NUMBER 31R977, TYPE NUMBER 0011-B1

KEY NO.	PART NO.	DESCRIPTION	KEY NO.	PART NO.	DESCRIPTION
559A	697561	Screw (Remote Choke Stop) (#8-32x.37)	1034	690822	Guide-Push Rod
562	691119	Screw (Governor Control Lever)	1036		Label-Emissions (Available from a Briggs & Stratton Authorized Dealer)
579	691029	Nut (Starter Cable)			
584	794682	Cover-Breather Passage	1040	699852	Plate-Trim
601	791850	Hose-Clamp (Green)	1044	698139	Screw (Flywheel)
614	691620	Pin-Cotter (Governor Crank)	1051	691265	Ring-Retaining
616	692012	Crank-Governor	1054	280275	Tie-Cable
617	692138	Seal-O Ring (Intake Manifold) (Red)	1058	276344	Operator's Manual
633	699813	Seal-Choke/Throttle Shaft (Choke Shaft)	1059	698516	Kit-Screw/Washer (Alternator)
634	698779	Spring/Seal Assembly (Choke Shaft)	1090	691293	Retainer-Brush
635	691909	Boot-Spark Plug	1091	691333	Cap-Limiter
654	690958	Nut (Carburetor) (Serrated)	1095	794152	Gasket Set-Valve
684	697157	Screw (Breather Assembly)	1119	691183	Screw (Alternator)
691	692407	Seal-Governor Shaft	1127	695407	Screw (Float Bowl)
697	791680	Screw (Drive Cap)	1136	699891	Screw (High Speed Control)
718	690959	Pin-Locating	1263	697124	Reed-Breather
724	697478	Link-Starter Switch	1264	697104	Screw (Breather Reed)
729	691224	Clip-Wire	1266	691917	Seal-O Ring (Intake Elbow) (Red)
741	697128	Gear-Timing	1266A	697123	Seal-O Ring (Intake Elbow)
750	790832	Screw (Oil Pump Cover)	1270	793243	Plug-AVS Counterweight
757	793242	Link-Counterweight	1329	N/A	Replacement Engine (Not Available at This Printing)
758	793763	Counterweight	1330	N/A	Repair Manual (Not Available at This Printing)
759	697392	Pin-Counterweight			
783	693713	Gear-Pinion			
789	698329	Harness-Wiring			
797	693167	Nut (Brush Retainer)			
801	691283	Cap-Drive			
802	691286	Cap-End			
830	691095	Stud-Rocker Arm			
842	691031	Seal-O Ring (Dipstick Tube)			
847	790442	Dipstick/Tube Assembly			
850	100106	Sealant-Liquid			
851	692424	Terminal-Spark Plug			
868	690968	Seal-Valve			
877	790544	Wire/Connector-Alternator			
883	692236	Gasket-Exhaust			
914	691108	Screw (Rocker Cover)			
943	690589	Seal-O Ring (Oil Pump Cover)			
947	699915	Solenoid-Fuel			
964	799159	Cap-Connector			
965	499613	Cover-Oil Pump			
968	591647	Cover-Air Cleaner			
975	699502	Bowl-Fuel			
987	698777	Seal-Throttle Shaft			
1005	796083	Fan-Flywheel			
1017	796981	Screen-Oil Pump			
1022	272475s	Gasket-Rocker Cover			
1023	797421	Cover-Rocker			
1024	794644	Pump-Oil			
1026	692003	Rod-Push (Intake) (Aluminum)			
1026A	6920011	Rod-Push (Exhaust) (Steel)			
1027	492932s	Filter-Oil			
1029	691751	Arm-Rocker			

NOTE: All component dimensions given in U.S. inches
1 inch = 25.4 mm

SERVICE NOTES

SERVICE NOTES

LIMITED WARRANTY ON CRAFTSMAN RIDING EQUIPMENT

For two (2) years from the date of purchase, if this Craftsman Riding Equipment is maintained, lubricated and tuned up according to the instructions in the owner's manual, Sears will repair or replace free of charge any parts that are found to be defective in material or workmanship according to the guidelines of coverage listed below. Sears will also provide free labor for these applicable warranted parts for the two full years. During the first 30 days of purchase, there will be no charges to service the product at your home for issues covered by this warranty. (See exclusions below). For your convenience, IN HOME warranty service will still be available after the first 30 days of purchase, but a trip charge will apply. This charge will be waived if the Craftsman product is dropped off at an authorized Sears location. For the nearest authorized Sears location, please call 1-800-4-MY-HOME®. This warranty applies only while this product is within the United States.

This Warranty does not cover:

- Expendable items which become worn during normal use, including but not limited to blades, spark plugs, air cleaners, belts, and oil filters.
- Standard Maintenance Servicing, oil changes, or tune-ups
- Tire replacement or repair caused by punctures from outside objects, such as nails, thorns, stumps, or glass.
- Repairs necessary because of operator abuse, including but not limited to, damage caused by towing objects beyond the capability of the riding equipment, impacting objects that bend the frame or crankshaft, or over-speeding the engine.
- Repairs necessary because of operator negligence, including but not limited to, electrical and mechanical damage caused by improper storage, failure to use the proper grade and amount of engine oil, failure to keep the deck clear of flammable debris, or failure to maintain the equipment according to the instructions contained in the owner's manual.
- Engine (fuel system) cleaning or repairs caused by fuel determined to be contaminated or oxidized (stale). In general, fuel should be used within 30 days of its purchase date.
- Normal deterioration and wear of the exterior finishes, or product label replacement.
- Riding equipment used for commercial or rental purposes.

LIMITED WARRANTY ON BATTERY

For ninety (90) days from date of purchase, if any battery included with this riding equipment proves defective in material or workmanship and our testing determines the battery will not hold a charge, Sears will replace the battery at no charge. During the first 30 days of purchase, there will be no charges to replace the battery at your HOME. After the first 30 days, for your convenience, IN-HOME warranty service will still be available but a trip charge will apply. This charge will be waived if the Craftsman product is dropped off at an authorized Sears location. For the nearest authorized Sears location, please call 1-800-4-MY-HOME®.

This battery warranty applies only while this product is within the United States.

This warranty gives you specific legal rights, and you may also have other rights, which vary, from state to state.

Sears Brands Management Corporation, Dept.817WA, Hoffman Estates, IL 60179

