

SEARS

**OWNER'S
MANUAL**

**MODEL NO.
944.525431**

Caution:
Read and follow
all Safety Rules
and Instructions
Before Operating
This Equipment

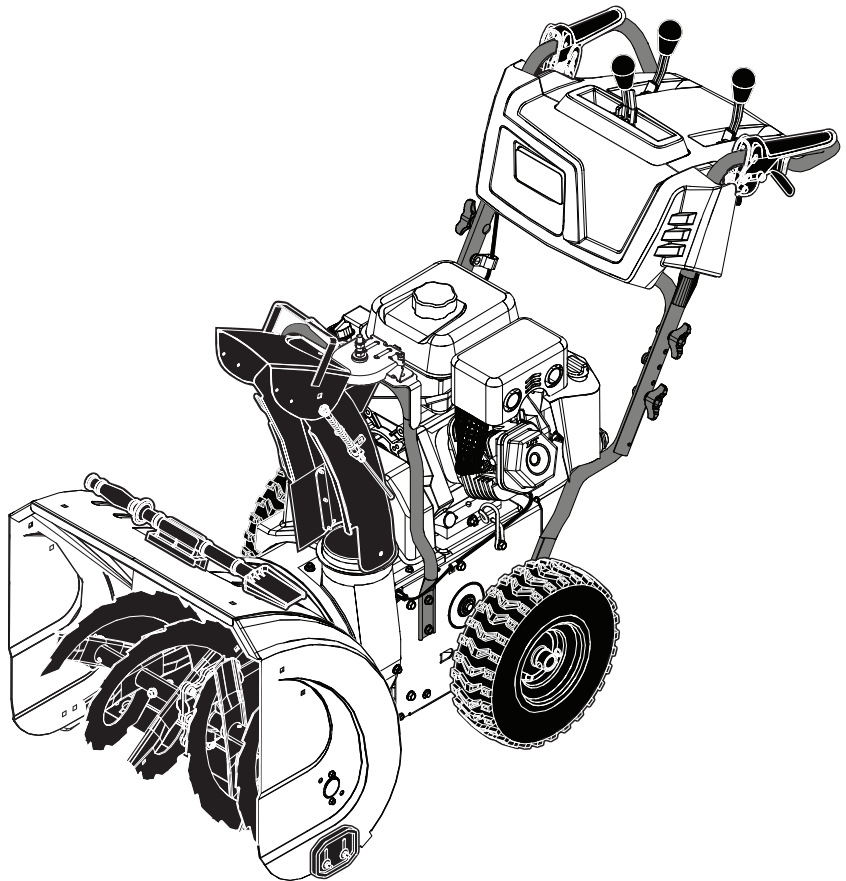

CRAFTSMAN®

**1450 SERIES B&S ENGINE
30" TWO-STAGE
POWER-PROPELLED
SNOW THROWER**

- Assembly
- Operation
- Maintenance
- Service and Adjustments
- Repair Parts

Gasoline containing up to 10% ethanol (E10) is acceptable for use in this machine.
The use of any gasoline exceeding 10% ethanol (E10) will void the product warranty.

Sears Canada, Inc., Toronto, Ontario M5B 2B8

582344101 Rev. 1

IMPORTANT

Safe Operation Practices for Walk-Behind Snow Throwers

This snow thrower is capable of amputating hands and feet and throwing objects. Failure to observe the following safety instructions could result in serious injury.



Look for this symbol to point out important safety precautions. It means **CAUTION!!! BECOME ALERT!!! YOUR SAFETY IS INVOLVED.**



WARNING: Always disconnect spark plug wire and place it where it cannot contact plug in order to prevent accidental starting when setting up, transporting, adjusting or making repairs.



WARNING: This snow thrower is for use on sidewalks, driveways and other ground level surfaces. Caution should be exercised while using on sloping surfaces. Do not use snow thrower on surfaces above ground level such as roofs of residences, garages, porches or other such structures or buildings.



WARNING: Snow throwers have exposed rotating parts, which can cause severe injury from contact, or from material thrown from the discharge chute. Keep the area of operation clear of all persons, small children and pets at all times including startup.



CAUTION: Muffler and other engine parts become extremely hot during operation and remain hot after engine has stopped. To avoid severe burns on contact, stay away from these areas.



WARNING: Engine exhaust, some of its constituents, and certain vehicle components contain or emit chemicals known to the State of California to cause cancer and birth defects or other reproductive harm.

Training

1. Read, understand and follow all instructions on the machine and in the manual(s) before operating this unit. Be thoroughly familiar with the controls and the proper use of the equipment. Know how to stop the unit and disengage the controls quickly.
2. Never allow children to operate the equipment. Never allow adults to operate the equipment without proper instruction.
3. Keep the area of operation clear of all persons, particularly small children.
4. Exercise caution to avoid slipping or falling, especially when operating the snow thrower in reverse.

Preparation

1. Thoroughly inspect the area where the equipment is to be used and remove all doormats, sleds, boards, wires, and other foreign objects.
2. Disengage all clutches and shift into neutral before starting the engine (motor).
3. Do not operate the equipment without wearing adequate winter garments. Avoid loose fitting clothing that can get caught in moving parts. Wear footwear that will improve footing on slippery surfaces.
4. Handle fuel with care; it is highly flammable
 - (a) Use an approved fuel container.
 - (b) Never add fuel to a running engine or hot engine.
 - (c) Fill fuel tank outdoors with extreme care. Never fill fuel tank indoors.
 - (d) Never fill containers inside a vehicle or on a truck or trailer bed with a plastic liner. Always place containers on the ground, away from your vehicle, before filling.
 - (e) When practical, remove gas-powered equipment from the truck or trailer and refuel it on the ground. If this is not possible, then refuel such equipment on a trailer with a portable container, rather than from a gasoline dispenser nozzle.

- (f) Keep the nozzle in contact with the rim of the fuel tank or container opening at all times, until refueling is complete. Do not use a nozzle lock-open device.
 - (g) Replace gasoline cap securely and wipe up spilled fuel.
 - (h) If fuel is spilled on clothing, change clothing immediately.
5. Use extension cords and receptacles as specified by the manufacturer for all units with electric drive motors or electric starting motors.
 6. Adjust the collector housing height to clear gravel or crushed rock surface.
 7. Never attempt to make any adjustments while the engine (motor) is running (except when specifically recommended by manufacturer).
 8. Always wear safety glasses or eye shields during operation or while performing an adjustment or repair to protect eyes from foreign objects that may be thrown from the machine.

Operation

1. Do not put hands or feet near or under rotating parts. Keep clear of the discharge opening at all times.
2. Exercise extreme caution when operating on or crossing gravel drives, walks, or roads. Stay alert for hidden hazards or traffic.
3. After striking a foreign object, stop the engine (motor), remove the wire from the spark plug, disconnect the cord on electric motors, thoroughly inspect the snow thrower for any damage, and repair the damage before restarting and operating the snow thrower.
4. If the unit should start to vibrate abnormally, stop the engine (motor) and check immediately for the cause. Vibration is generally a warning of trouble.
5. Stop the engine (motor) whenever you leave the operating position, before unclogging the collector/impeller housing or discharge chute, and when making any repairs, adjustments or inspections.

6. When cleaning, repairing or inspecting the snow thrower, stop the engine and make certain the collector/impeller and all moving parts have stopped. Disconnect the spark plug wire and keep the wire away from the plug to prevent someone from accidentally starting the engine.
7. Do not run the engine indoors, except when starting the engine and for transporting the snow thrower in or out of the building. Open the outside doors; exhaust fumes are dangerous.
8. Exercise extreme caution when operating on slopes.
9. Never operate the snow thrower without proper guards, and other safety protective devices in place and working.
10. Never direct the discharge toward people or areas where property damage can occur. Keep children and others away.
11. Do not overload the machine capacity by attempting to clear snow at too fast a rate.
12. Never operate the machine at high transport speeds on slippery surfaces. Look behind and use care when operating in reverse.
13. Disengage power to the collector/impeller when snow thrower is transported or not in use.
14. Use only attachments and accessories approved by the manufacturer of the snow thrower (such as wheel weights, counterweights, or cabs).
15. Never operate the snow thrower without good visibility or light. Always be sure of your footing, and keep a firm hold on the handles. Walk; never run.

16. Never touch a hot engine or muffler.

Clearing a Clogged Discharge Chute

Hand contact with the rotating impeller inside the discharge chute is the most common cause of injury associated with snow throwers. Never use your hand to clean out the discharge chute. To clear the chute:

1. SHUT THE ENGINE OFF!
2. Wait 10 seconds to be sure the impeller blades have stopped rotating.
3. Always use a clean-out tool, not your hands.

Maintenance and Storage

1. Check shear bolts and other bolts at frequent intervals for proper tightness to be sure the equipment is in safe working condition.
2. Never store the machine with fuel in the fuel tank inside a building where ignition sources are present such as hot water heaters, space heaters, or clothes dryers. Allow the engine to cool before storing in any enclosure.
3. Always refer to operator's manual for important details if the snow thrower is to be stored for an extended period.
4. Maintain or replace safety and instruction labels, as necessary.
5. Run the machine a few minutes after throwing snow to prevent freeze-up of the collector/impeller.

CONGRATULATIONS on your purchase of a new snow thrower. It has been designed, engineered and manufactured to give best possible dependability and performance.

Should you experience any problem you cannot easily remedy, please contact your nearest authorized service center. We have competent, well-trained technicians and the proper tools to service or repair this unit.

Please read and retain this manual. The instructions will enable you to assemble and maintain your snow thrower properly. Always observe the "SAFETY RULES".

SERIAL NUMBER: _____

DATE OF PURCHASE: _____

THE MODEL AND SERIAL NUMBERS WILL BE FOUND ON A DECAL ATTACHED TO THE REAR OF THE SNOW THROWER HOUSING.

YOU SHOULD RECORD BOTH SERIAL NUMBER AND DATE OF PURCHASE AND KEEP IN A SAFE PLACE FOR FUTURE REFERENCE.

PRODUCT SPECIFICATIONS

Gasoline Capacity and Type:	0.8 Gallons (3,0 Liters) Unleaded Regular only
Oil Type (API SG-SL):	SAE 5W-30 or 10W-30 Synthetic SAE 5W-30
Oil Capacity:	28 Ounces (0,8 Liters)
Spark Plug: Gap:	Champion RC12YC 0.030" (0,762 mm)

CUSTOMER RESPONSIBILITIES

- Read and observe the safety rules.
- Follow a regular schedule in maintaining, caring for and using your snow thrower.
- Follow the instructions under "Maintenance" and "Storage" sections of this owner's manual.

TABLE OF CONTENTS

SAFETY RULES	2-3
PRODUCT SPECIFICATIONS	3
CUSTOMER RESPONSIBILITIES	3
WARRANTY	4
ASSEMBLY / PRE-OPERATION	5-7
OPERATION	8-13
MAINTENANCE SCHEDULE	14

MAINTENANCE	14-15
SERVICE AND ADJUSTMENTS	16-18
STORAGE	19
TROUBLESHOOTING	20
REPAIR PARTS	22-42
ENGINE BREAKDOWN	43-47

GENERAL: Craftsman products are warranted to be free from defects in materials or workmanship for a specific time period as set-out below (the "Warranty Period"). Warranties extend to the original purchaser of a Craftsman product only. Purchases made through an online auction or through any website other than www.sears.ca are excluded. The relevant Warranty Period commences on the original date of purchase. Within this period, SEARS CANADA, Inc. will, at its sole option, repair or replace any products or components which fail in normal use. Such repairs or replacement will be made at no charge to the customer for parts or labor, provided that the customer shall be responsible for any transportation cost.

EXCLUSIONS: This warranty does not cover failures due to normal wear, abuse, misuse, neglect (including but not limited to the use of stale fuel, dirt, abrasives, moisture, rust, corrosion, or any adverse reaction due to improper storage or use habits), improper maintenance or failure to follow maintenance guidelines and/or instructions, failure to operate the product in accordance with the owner's manual or any additional instructions or information provided at the time of purchase or in subsequent communications with the original purchaser, accident or unauthorized alterations or repairs made or attempted by others. Also excluded from warranty coverage - except as provided below - are the following: maintenance, adjustments, components subject to wear including but not limited to: cosmetic components, belts, blades, blade adapters, bulbs, tires, filters, guide bars, lubricants, seats, grips, recoil assy's, saw chains and bars, trimmer lines and spools, spark plugs, starter ropes and tines, and discoloration resulting from ultraviolet light. Any product missing the model and/or serial number identification label will be disqualified from coverage under this warranty.

REPAIRS: Repairs have a 90 day warranty. If the defective product is still within the Warranty Period, then the new warranty is 90 days from the date of repair or to the end of the original Warranty Period, whichever period is longer.

DISCLAIMERS: THE WARRANTIES AND REMEDIES CONTAINED HEREIN ARE EXCLUSIVE AND IN LIEU OF ALL OTHER WARRANTIES, WHETHER ORAL OR WRITTEN (OTHER THAN AS STATED HEREIN), AND WHETHER EXPRESS, IMPLIED OR STATUTORY, INCLUDING BUT NOT LIMITED TO ANY. THIS WARRANTY GIVES YOU SPECIFIC LEGAL RIGHTS, WHICH MAY VARY FROM PROVINCE TO PROVINCE.

IN NO EVENT SHALL SEARS BE LIABLE FOR ANY INCIDENTAL, SPECIAL, INDIRECT OR CONSEQUENTIAL DAMAGES, WHETHER RESULTING FROM THE USE, MISUSE OR INABILITY TO USE THE PRODUCT OR FROM DEFECTS IN THE PRODUCT. THE EXCLUSIONS IN THIS PARAGRAPH SHALL NOT APPLY IN JURISDICTIONS WHERE APPLICABLE LAW DOES NOT ALLOW FOR THE EXCLUSION OF INCIDENTAL OR CONSEQUENTIAL DAMAGES. IN SUCH JURISDICTIONS, THIS PARAGRAPH SHALL NOT APPLY, BUT THE REMAINING PROVISIONS OF THIS DOCUMENT SHALL REMAIN VALID.

SEARS retains the exclusive right to repair or replace the product or offer a full refund of the purchase price at its sole discretion. SUCH REMEDY SHALL BE YOUR SOLE AND EXCLUSIVE REMEDY FOR ANY BREACH OF WARRANTY.

CUSTOMER RESPONSIBILITIES: In addition to complying with all suggested maintenance guidelines and instructions, customers' obligations shall include but shall not be limited to: operating the product in accordance with the owner's manual or any additional instructions or information provided at the time of purchase or in subsequent communications to the purchaser from time to time, exhibit reasonable care in the use, operation, maintenance, general upkeep and storage of the product. Failure to comply with these requirements will void any applicable warranty.

LIST OF APPLICABLE WARRANTY PERIODS: The following list contains the applicable Warranty Period for your Craftsman product and is based on a combination of the type of product or component and the intended and actual use of the product or component:

1. **90 DAYS:** Craftsman products intended for use or actually used for commercial, institutional, professional or income-producing purposes
2. **2 YEARS:** Craftsman riding lawn mowers, yard and garden tractors, walk behind mowers, tillers, brush cutters, snow blowers, handheld blowers, backpack blowers, hedge trimmers and electrical products for noncommercial, nonprofessional, non-institutional, or non-income-producing use, except for those components which are part of engine systems manufactured by third party engine manufacturers for which the purchase has received a separate warranty with product information supplied at the time of purchase.
3. **1 YEAR:** Craftsman power cutters, stump grinders, pole pruners, gas chain saws, electric chain saws, trimmer attachments, baggers and pole saws for noncommercial, nonprofessional, non-institutional, or non-income-producing use.
4. **90 DAYS:** All defective batteries, which will be replaced during this 90-day Warranty Period.
5. **60 DAYS:** Additional Warranty Period of 60 days will apply to adjustments and worn products or components BUT DOES NOT INCLUDE WEAR OR ADJUSTMENTS for products used for commercial, institutional, professional or income-producing purposes. Wear items include but are not limited to: belts, blades, tires, spark plugs, air filters, chains, shear bolts, skid plates, scraper bars, drift cutters, ropes, tines, collection bags and pulleys.

As the Warranty Period runs from the date of purchase and NOT from the date that a product is delivered, opened, assembled or first used, please ensure during this time period that your product or component has been assembled and tested for correction operation regardless of when you intend to actually use it. Claims made after the Warranty Period has expired will not be honored.

PROOF OF PURCHASE/DOCUMENTATION: Warranty coverage is conditioned upon the original purchaser furnishing SEARS CANADA or its authorized third party service provider if applicable, with the original sales receipt or other adequate written proof of the original purchase date and identification of the product. In the event that the original purchaser is unable to provide a company of the original sales receipt, SEARS CANADA Inc. reserves the right to determine in its sole discretion what other written proof of the original purchase date and identification of the product is acceptable.

PARTS PACKED SEPARATELY IN CARTON

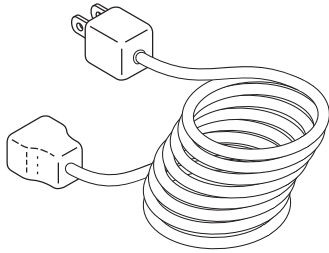

(1) POWER CORD

EXTRA SHEAR BOLTS AND NUTS

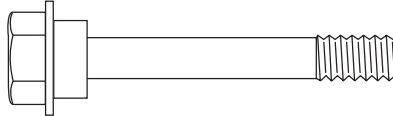

(2) SHEAR BOLTS 1/4-20 x 1-3/4

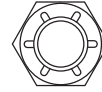

(2) LOCKNUTS
1/4-20

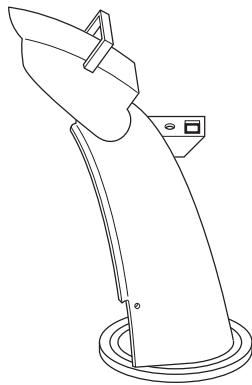

(1) DISCHARGE CHUTE

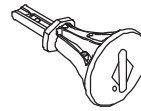

SAFETY IGNITION KEY (S)



(3) KNOB

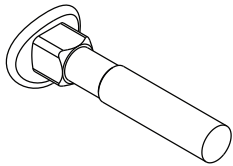

(2) CARRIAGE BOLTS
5/16-18 x 2 1/4"



(2) HANDLE KNOBS

ROTATOR HEAD MOUNTING



(1) LOCKNUT 3/8

CHUTE DEFLECTOR REMOTE CONTROL

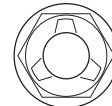

(1) LOCKNUT
5/16-18

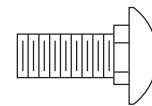

(1) CARRIAGE BOLT
5/16-18 x 5/8

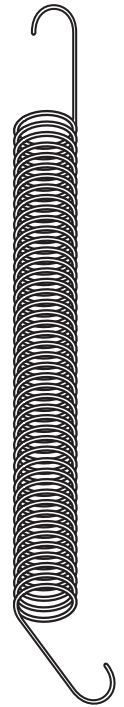

(1) SPRING



(1) LOCKNUT
1/4-20



(1) NYLON
WASHER

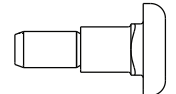

(1) SHOULDER
BOLT 1/4-20

ASSEMBLY / PRE-OPERATION

Read these instructions and this manual in its entirety before you attempt to assemble or operate your new snow thrower. Reading the entire manual will familiarize you with the unit, which will assist you in assembly, operation and maintenance of the product.

Your new snow thrower has been assembled at the factory with the exception of those parts left unassembled for shipping purposes. All parts such as nuts, washers, bolts, etc., necessary to complete the assembly have been placed in the parts bag. To ensure safe and proper operation of your snow thrower, all parts and hardware you assemble must be tightened securely. Use the correct tools as necessary to ensure proper tightness.

REMOVE SNOW THROWER FROM CARTON

1. Remove all accessible loose parts and parts boxes from carton.
2. Cut down all four corners of carton and lay panels flat.
3. Remove the two (2) screws securing the auger housing to the pallet and remove additional steel brackets from skid plate if equipped.
4. Remove all packing materials.
5. Remove plastic ties securing the snow thrower to the pallet.
6. Remove snow thrower from carton and check carton thoroughly for additional loose parts.

HOW TO SET UP YOUR SNOW THROWER

Store the extra shear bolts and nuts provided in parts bag.

UNFOLD UPPER HANDLE (See Figs. 1-3)

1. Raise upper handle to the operating position.

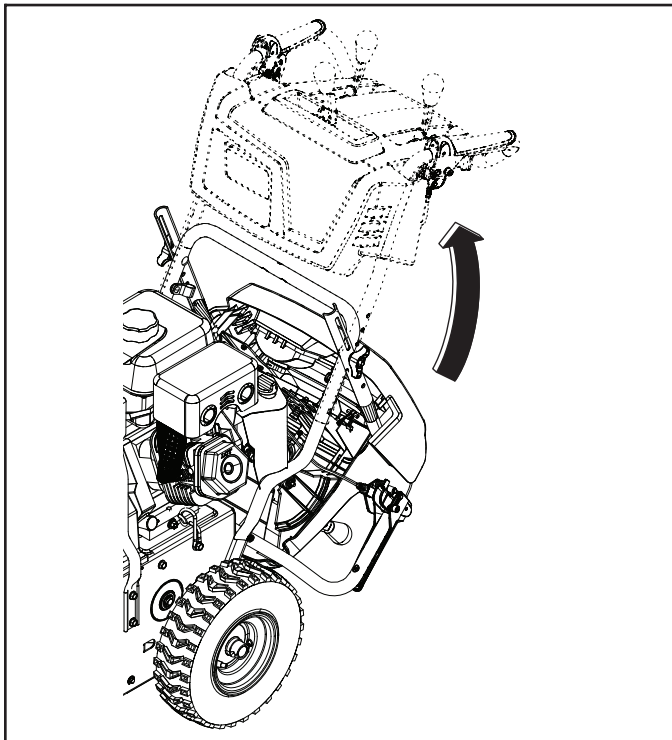

FIG. 1

2. Adjust the handle height to desired position using the appropriate mounting holes and tighten lower handle knobs securely.

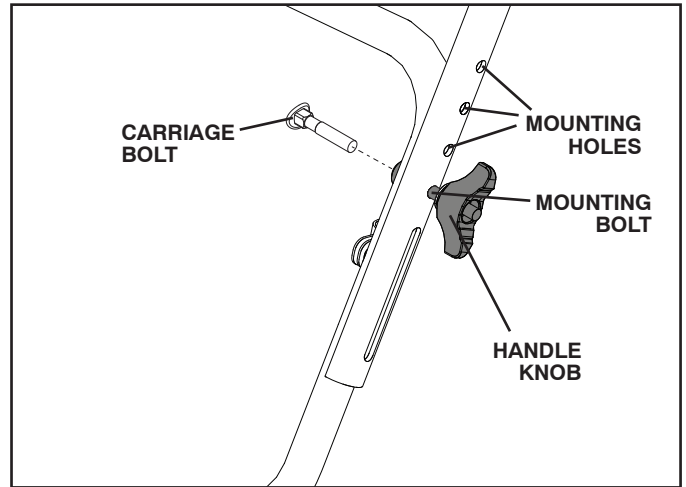

FIG. 2

3. Install the additional carriage bolts and handle knobs that are supplied in the bag of parts to secure upper handle to lower handle.

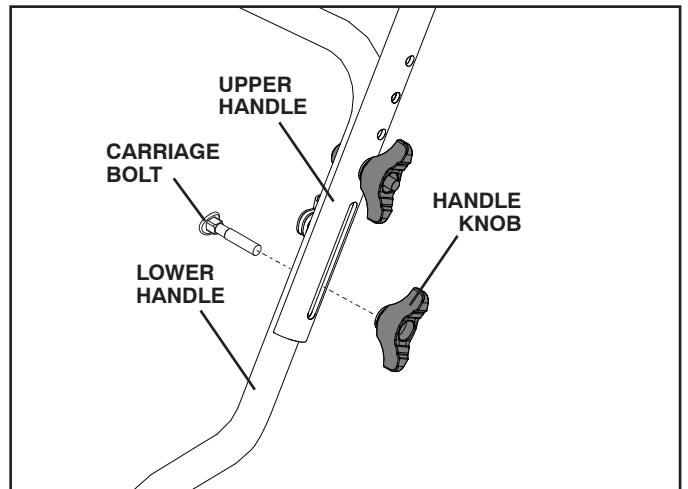

FIG. 3

ASSEMBLY / PRE-OPERATION

INSTALL DISCHARGE CHUTE/CHUTE ROTATOR HEAD (See Fig. 4 and 5)

1. Place discharge chute assembly on top of chute base with discharge opening toward front of snow thrower.
2. Position chute rotator head over chute bracket. If necessary, rotate chute assembly to align square and pin on underside of chute rotator head with holes in chute bracket.
3. With chute rotator head and chute bracket aligned, position chute rotator head on pin and threaded stud of mounting bracket.
4. Install locknut on threaded stud and tighten securely.

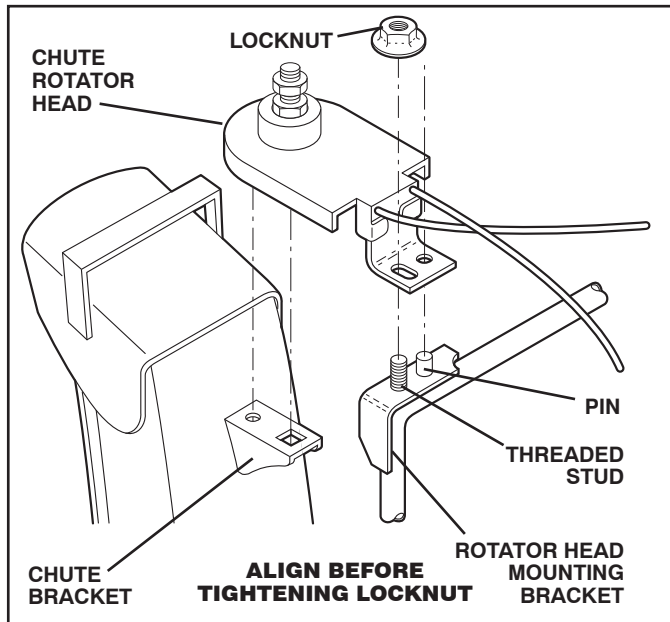

FIG. 4

5. Secure cables to the lower handle using the double clip.

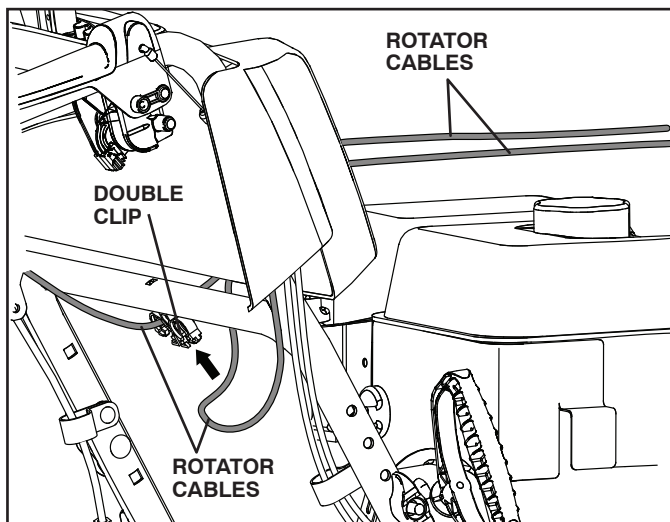

FIG. 5

INSTALL CHUTE DEFLECTOR REMOTE CONTROL (See Figs. 6 and 7)

1. Install remote cable bracket to discharge chute with 5/16-18 carriage bolt and 5/16-18 locknut as shown. Tighten securely.
2. Install remote cable eyelet to chute deflector with 1/4-20 shoulder bolt, nylon washer and 1/4-20 locknut as shown. Tighten nut securely. Eyelet will be loose on shoulder bolt.
3. Install spring hooks between hex nuts on chute rotator head and into hole in chute deflector as shown.

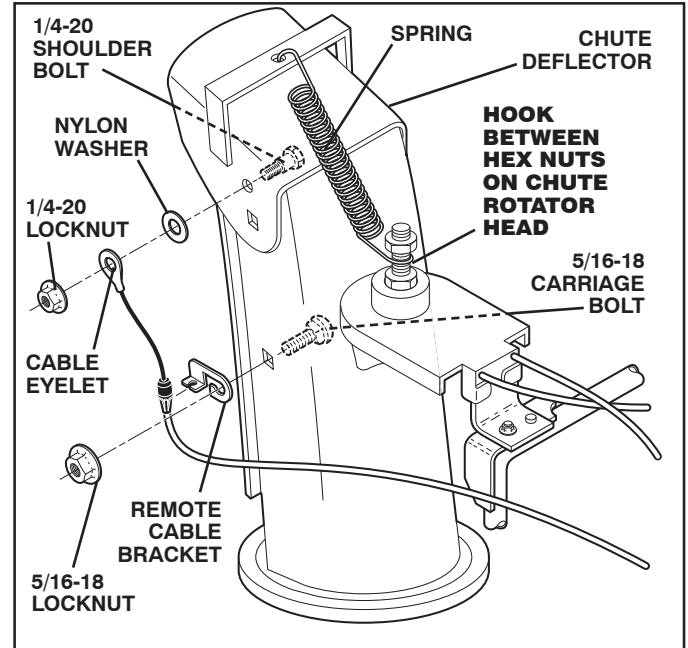

FIG. 6

4. Install all control lever knobs by pressing them down onto the control levers.

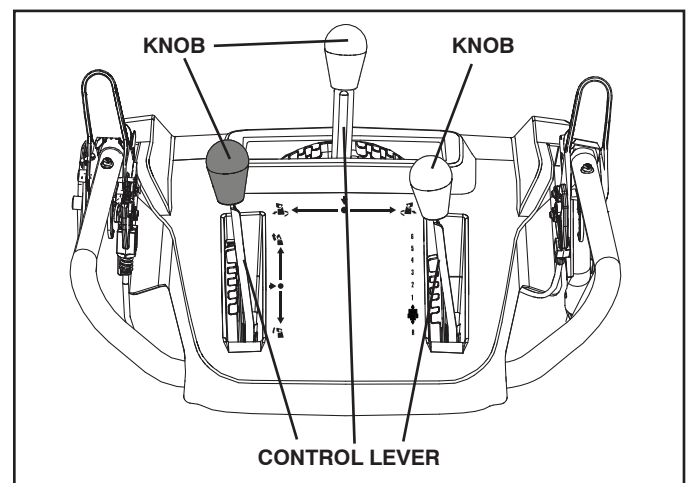

FIG. 7

CHECK TIRE PRESSURE

The tires on your snow thrower were overinflated at the factory for shipping purposes. Correct and equal tire pressure is important for best snow throwing performance.

- Reduce tire pressure to 14-17 PSI.

OPERATION

KNOW YOUR SNOW THROWER

READ THIS OWNER'S MANUAL AND ALL SAFETY RULES BEFORE OPERATING YOUR SNOW THROWER. Compare the illustrations with your snow thrower to familiarize yourself with the location of various controls and adjustments. Save this manual for future reference.

These symbols may appear on your snow thrower or in literature supplied with the product. Learn and understand their meaning.

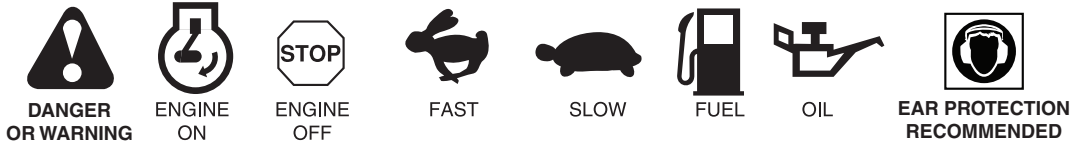

READ AND FOLLOW ALL SAFETY INFORMATION AND INSTRUCTIONS BEFORE USE OF THIS PRODUCT. KEEP THESE INSTRUCTIONS FOR FUTURE REFERENCE.



DANGER
 READ OPERATORS MANUAL
 DO NOT OPERATE ON STEEP SLOPES
 WATCH FOR THROWN OBJECTS
 OPERATE AT A SAFE DISTANCE FOR OTHER PEOPLE



1 IGNITION KEY. INSERT TO START AND RUN



2 CHOKE CLOSED (START)



3 PRIMER



4 RECOIL START



5 CHOKE OPEN (RUN)



6 IGNITION KEY. PULL OUT TO STOP



DANGER

DO NOT PLACE HANDS NEAR BLADES

REMOVE SPARK PLUG WIRE BEFORE PERFORMING MAINTENANCE



DANGER

READ OPERATORS MANUAL
 WATCH FOR THROWN OBJECTS
 OPERATE AT A SAFE DISTANCE FROM OTHER PEOPLE



DANGER, KEEP FEET AWAY



DANGER, KEEP HANDS AWAY



DISENGAGED

ENGAGED

TRACTION DRIVE CONTROL



SNOW DISCHARGE

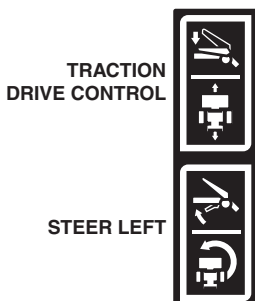

TRACTION DRIVE CONTROL

SNOW DISCHARGE

STEER LEFT

STEER RIGHT

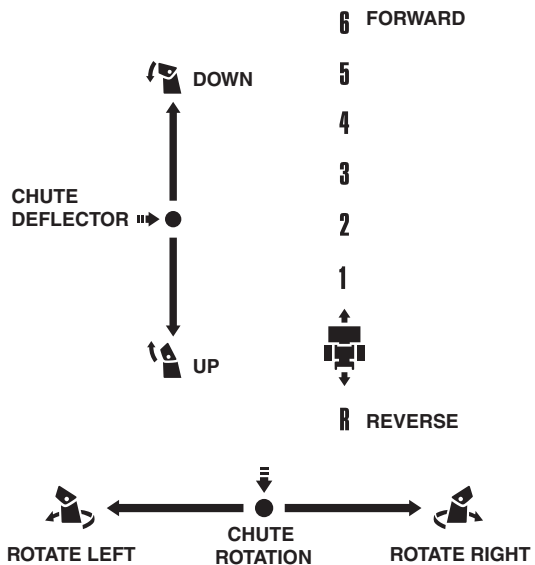

OPERATION

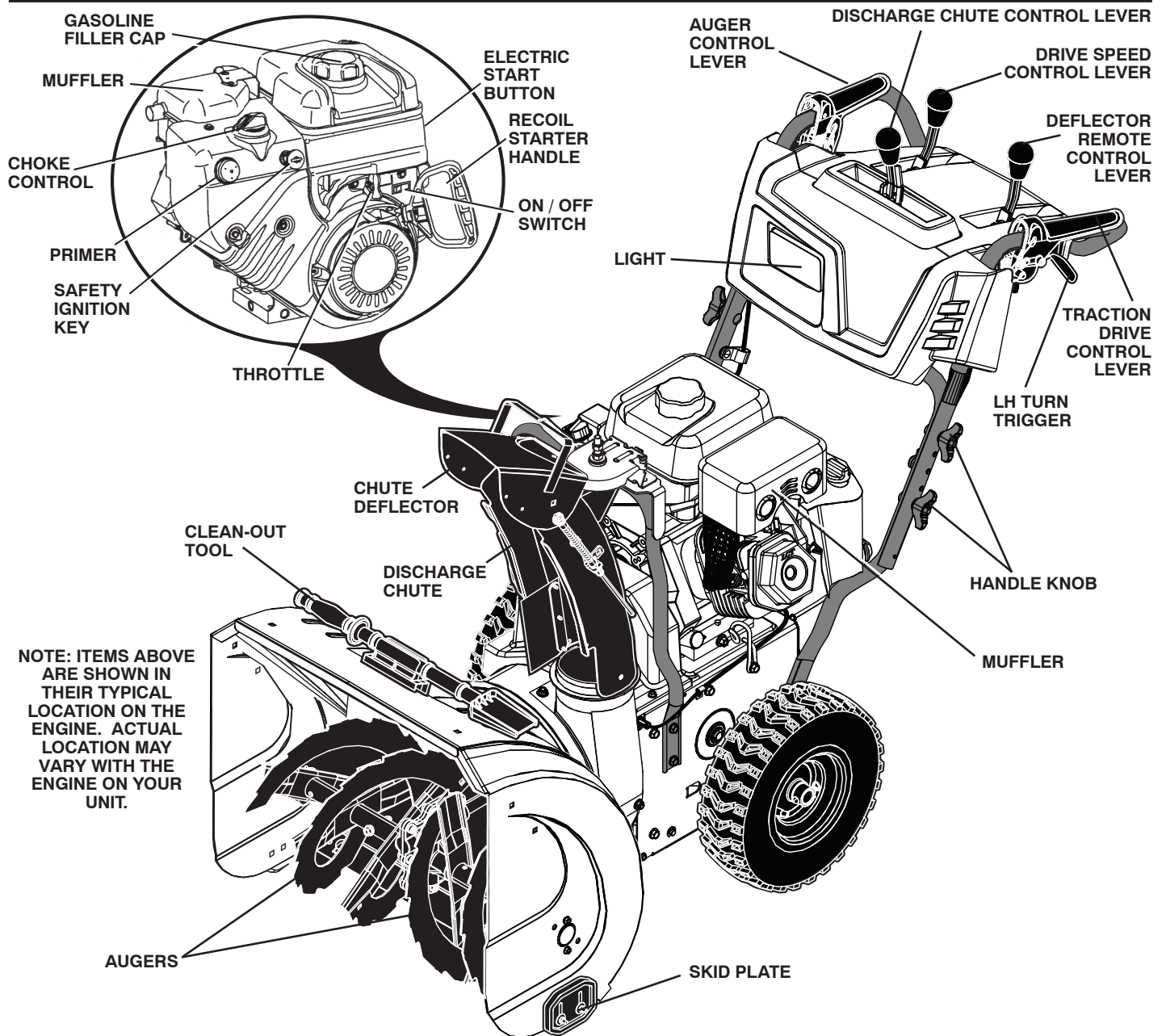

NOTE: ITEMS ABOVE ARE SHOWN IN THEIR TYPICAL LOCATION ON THE ENGINE. ACTUAL LOCATION MAY VARY WITH THE ENGINE ON YOUR UNIT.

FIG. 8

MEETS A.N.S.I. SAFETY REQUIREMENTS

Our snow throwers conform to the standards of the American National Standards Institute.

Safety ignition key - must be inserted for the engine to start and run. Remove when snow thrower is not in use.

Electric start button - used for starting the engine.

Recoil starter handle - used for starting engine.

Primer - pumps additional fuel from the carburetor to the cylinder for use when starting a cold engine.

Choke Control - used for starting a cold engine.

ON / OFF switch - used to STOP the engine.

Throttle - used to select FAST or SLOW engine speeds.

Drive speed control lever - used to select forward or reverse motion and speed of snow thrower.

LH and RH turn triggers - used to steer the snow thrower.

Traction drive control lever - used to engage power-propelled forward or reverse motion of snow thrower.

Auger control lever - used to engage auger motion (throw snow).

Discharge chute control lever - used to change the direction the snow is thrown.

Deflector remote control lever - used to change the distance the snow is thrown.

Skid plate - used to adjust height of scraper bar from the ground.

OPERATION



The operation of any snow thrower can result in foreign objects thrown into the eyes, which can result in severe eye damage. Always wear safety glasses or eye shields while operating your snow thrower or performing any adjustments or repairs. We recommend standard safety glasses or a wide vision safety mask worn over spectacles.

HOW TO USE YOUR SNOW THROWER

Know how to operate all controls before adding fuel or attempting to start the engine.

STOPPING

TRACTION DRIVE

- Release traction drive control lever to stop the forward or reverse movement of the snow thrower.

AUGER

- Release the auger control lever to stop throwing snow.

ENGINE

1. Move ON / OFF switch to "OFF" position.
2. Remove (do not turn) safety ignition key to prevent unauthorized use.

NOTE: Never use choke to stop engine.

TO USE CHOKE CONTROL (See Fig. 9)

The choke control is located on the engine. Use the choke control whenever you are starting a cold engine. Do not use to start a warm engine.

- To engage choke, turn knob counterclockwise. Slowly turn knob clockwise to disengage.

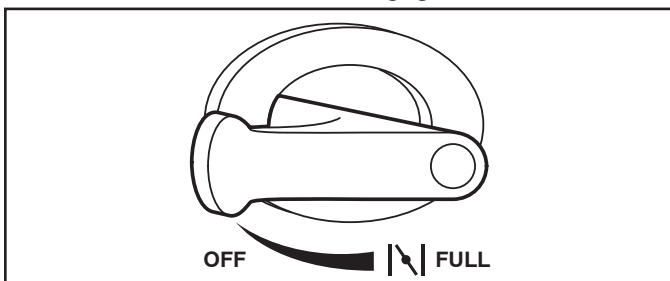

FIG. 9

TO USE THROTTLE CONTROL (See Fig. 10)

The throttle control is located on the engine. Always operate the snow thrower with the engine at full throttle. Full throttle offers the best snow thrower performance.

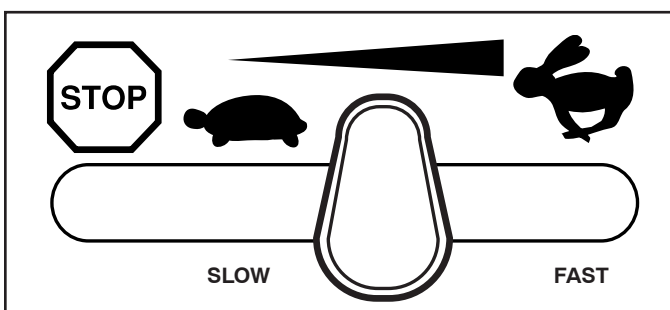

FIG. 10

TO CONTROL SNOW DISCHARGE (See Fig. 11)



WARNING: Snow throwers have exposed rotating parts, which can cause severe injury from contact, or from material thrown from the discharge chute. Keep the area of operation clear of all persons, small children and pets at all times including startup.



WARNING: If the discharge chute or auger become clogged, shut-off engine and wait for all moving parts to stop. Use the clean-out tool, NOT YOUR HANDS, to unclog the chute and/or auger.

The DIRECTION in which snow is to be thrown is controlled by the discharge chute control lever.

- To change the discharge chute position, pull backward on discharge chute control lever and move lever left or right until chute is in desired position. Be sure lever springs back and locks into desired position.

The DISTANCE that snow is thrown is controlled by the position of the chute deflector. Set the deflector low to throw snow a short distance; set the deflector higher to throw snow farther.

- Push right on chute deflector control lever and move lever forward to lower the deflector and decrease the distance. Move lever back to raise the deflector and increase the distance. Be sure lever springs back and locks into desired position.

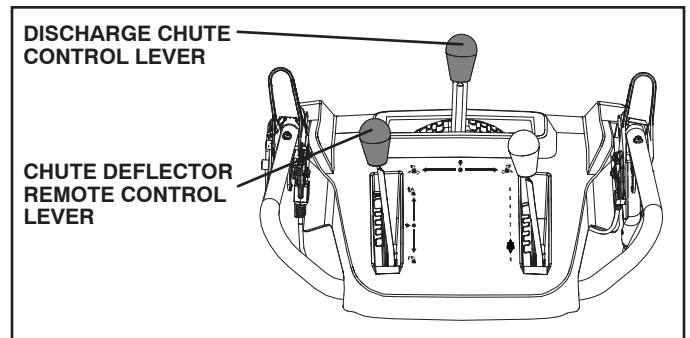

FIG. 11

TO THROW SNOW (See Fig. 12)

The auger rotation is controlled by the auger control lever located on the right side handle.

- Squeeze auger control lever to handle to engage the auger and throw snow.
- Release the auger control lever to stop throwing snow.

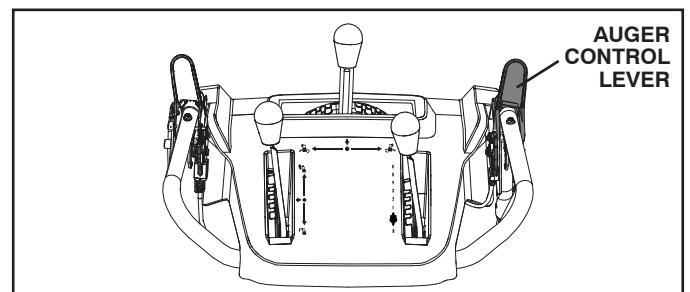

FIG. 12

OPERATION

USING THE CLEAN-OUT TOOL (See Fig. 13)

In certain snow conditions, the discharge chute may become clogged with ice and snow. Use the clean-out tool to dislodge this blockage.

When cleaning, repairing, or inspecting, make certain all controls are disengaged and the auger/impeller and all moving parts have stopped. Disconnect the spark plug wire and keep the wire away from the spark plug to prevent accidental starting.

- Release the auger control lever and shut off the engine.
- Remove the clean-out tool from its mounting clip. Grasp the tool firmly by the handle while pushing and twisting the tool into the discharge chute to dislodge the blockage.

After the packed snow has been dislodged, return the clean-out tool to its mounting clip by pushing it into the clip.

- Make sure the discharge chute is pointed in a safe direction (no vehicles, buildings, people, or other objects are in the direction of discharge) before restarting engine.
- Restart the engine, then squeeze the auger control lever to the handle to clear snow from the auger housing and the discharge chute.

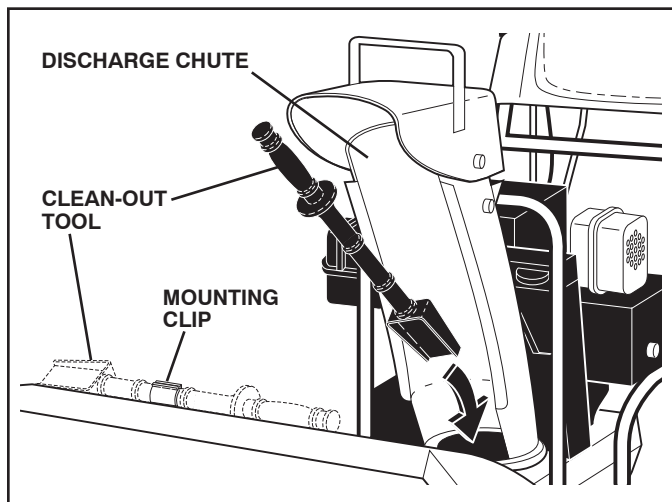

FIG. 13

TO MOVE FORWARD AND BACKWARD (See Fig. 14)

SELF-PROPELLING, forward and reverse movement of the snow thrower, is controlled by the traction drive control lever located on the left side handle.

- Squeeze traction drive control lever to handle to engage the drive system.
- Release traction drive control lever to stop the forward or reverse movement of the snow thrower.

SPEED and DIRECTION are controlled by the drive speed control lever.

- Push right on the speed control lever and move lever to desired position **BEFORE** engaging the traction drive control lever. Be sure lever springs back and locks into desired position.

CAUTION: Do not move speed control lever when traction drive control lever is engaged. Damage to the snow thrower can result.

- Slower speeds are for heavier snow and faster speeds are for light snow and transporting the snow thrower. It is recommended that you use a slower speed until you are familiar with the operation of the snow thrower.

NOTE: When both traction drive and auger control levers are engaged, the traction drive control lever will lock the auger control lever in the engaged position. This will allow you to release your right hand from the handle and adjust the discharge chute direction without interrupting the snow throwing process.

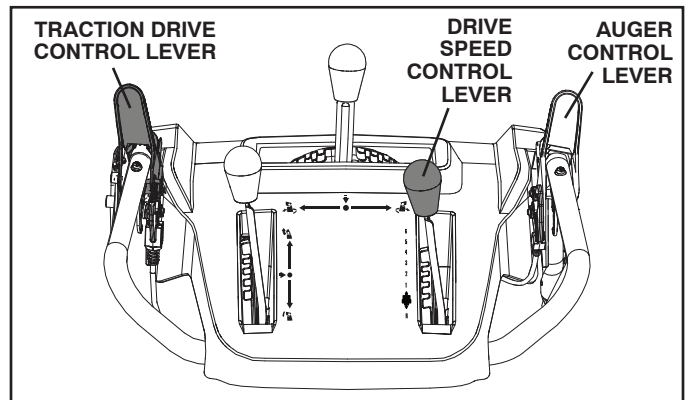

FIG. 14

POWER STEERING OPERATION (See Fig. 15)

Steering triggers are used to assist in steering your snow thrower. The triggers are located on the underside of each handle. When a trigger is squeezed, it disengages the drive wheel on that side of snow thrower and allows it to turn in that direction.

- To turn left – squeeze left side trigger.
- To turn right – squeeze right side trigger.

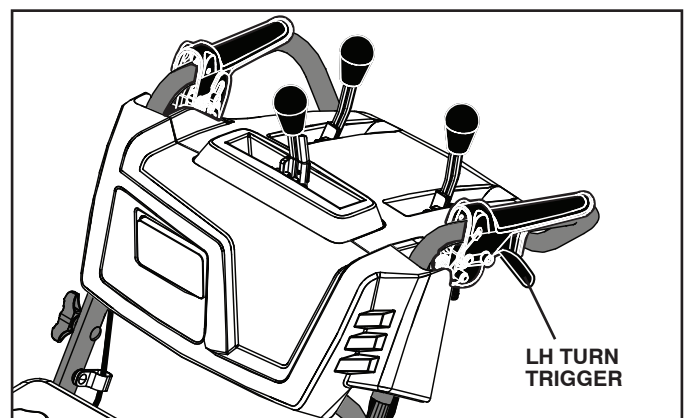

FIG. 15

OPERATION

TO ADJUST SKID PLATES (See Fig. 16)

NOTE: The wrench provided in your parts bag may be used to adjust the skid plates.

Skid plates are located on each side of the auger housing and adjust the clearance between the scraper bar and the ground surface. Adjust skid plates evenly to proper height for current surface conditions. For removal of snow in normal conditions, such as a paved driveway or sidewalk, place skid plates in the highest position (lowest scraper clearance) to give a 1/8" clearance between the scraper bar and the ground. Use a middle position if the surface to be cleared is uneven.

NOTE: It is not recommended to operate the snow thrower over gravel or rocky surfaces. Objects such as gravel, rocks or other debris, can easily be picked up and thrown by the impeller, which can cause serious personal injury, property damage or damage to the snow thrower.

- If snow thrower must be operated over gravel surface, use extra caution and be sure skid plates are adjusted to lowest (highest scraper clearance) position.
1. Shut off engine and wait for all moving parts to stop.
 2. Adjust skid plates by loosening the 1/2" hex nuts, then moving skid plate to desired position. Be sure both plates are adjusted evenly. Tighten securely.

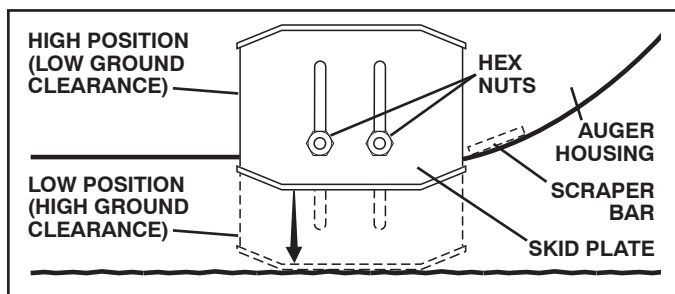

FIG. 16

SCRAPER BAR (See Fig. 16)

The scraper bar is not adjustable, but is reversible. After considerable use it may become worn. When it has worn almost to the edge of the housing, it can be reversed, providing additional service before requiring replacement. Replace a damaged or worn scraper bar.

BEFORE STARTING THE ENGINE

CHECK ENGINE OIL LEVEL (See Fig. 17)

The engine on your snow thrower has been shipped from the factory already filled with oil.

1. Check engine oil with snow thrower on level ground.
 2. Remove oil fill cap/dipstick and wipe clean, reinsert the dipstick and screw tight, wait for a few seconds, remove and read oil level. If necessary, add oil until "FULL" mark on dipstick is reached. Do not overfill.
- To change engine oil, see "TO CHANGE ENGINE OIL" in the Maintenance section of this manual.

ADD GASOLINE (See Fig. 17)

- Fill fuel tank to bottom of tank filler neck. Do not overfill. Use fresh, clean, regular unleaded gasoline with a minimum of 87 octane. Do not mix oil with gasoline. Purchase fuel in quantities that can be used within 30 days to assure fuel freshness.



WARNING: Wipe off any spilled oil or fuel. Do not store, spill or use gasoline near an open flame.

CAUTION: Alcohol blended fuels (called gasohol or using ethanol or methanol) can attract moisture which leads to separation and formation of acids during storage. Acidic gas can damage the fuel system of an engine while in storage. To avoid engine problems, the fuel system should be emptied before storage of 30 days or longer. Drain the gas tank, start the engine and let it run until the fuel lines and carburetor are empty. Use fresh fuel next season. See Storage Instructions for additional information. Never use engine or carburetor cleaner products in the fuel tank or permanent damage may occur.

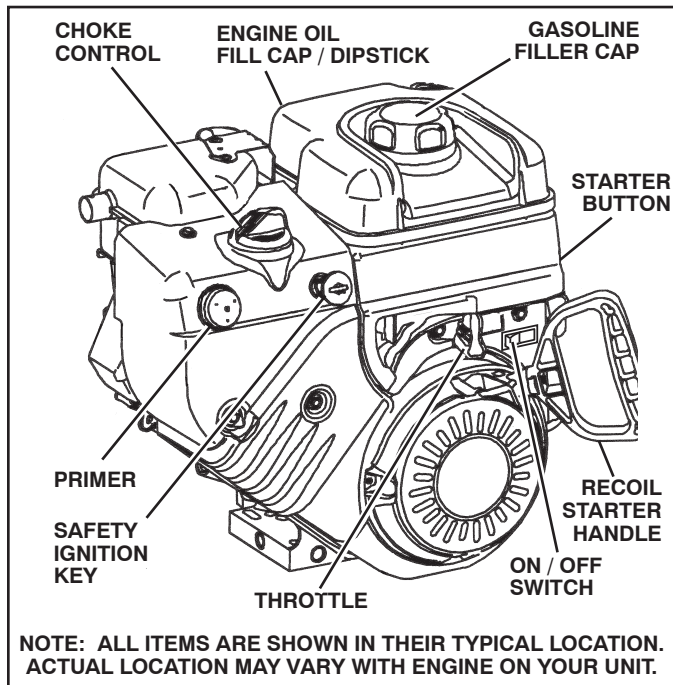

NOTE: ALL ITEMS ARE SHOWN IN THEIR TYPICAL LOCATION. ACTUAL LOCATION MAY VARY WITH ENGINE ON YOUR UNIT.

FIG. 17

OPERATION

TO START ENGINE

Your snow thrower engine is equipped with both a 120 Volt A.C. electric starter and a recoil starter. The electric starter is equipped with a three-wire power plug and is designed to operate on 120 Volt A.C. household current.

- Ensure your house is a 120 Volt A.C. three-wire grounded system. If you are uncertain, consult a licensed electrician.

NOTE: Use an extension cord recommended for outdoor use that is not longer than 50 feet (15 m).



WARNING: Do not use the electric starter if your house is not a 120 Volt A.C. three-wire grounded system. Serious personal injury or damage to your snow thrower could result.

COLD START - ELECTRIC STARTER

1. Insert safety ignition key (tied to recoil start cord) into ignition slot until it clicks. **DO NOT** turn the key. Keep the extra safety ignition key in a safe place.
2. Place throttle control in "FAST" position.
3. Place ON / OFF switch in "ON" position.
4. Rotate choke control to "FULL" position.
5. Push the primer three (3) times.

NOTE: Over priming may cause flooding, preventing the engine from starting. If you do flood the engine, wait a few minutes before attempting to start and **DO NOT** push the primer.

6. Connect the extension cord to the engine.
7. Plug the other end of the extension cord into a three-hole grounded 120 Volt A.C. receptacle.
8. Push starter button until engine starts.

IMPORTANT: Do not crank engine more than five continuous seconds between each time you try to start. Wait 5 to 10 seconds between each attempt.

9. When the engine starts, release the starter button and slowly move the choke control to the "OFF" position.
10. Disconnect the extension cord from the receptacle first, then from the engine.

Allow the engine to warm up for a few minutes. Engine will not develop full power until it has reached normal operating temperature.

WARM START - ELECTRIC STARTER

Follow the steps above, keeping the choke control in the "OFF" position.

COLD START - RECOIL STARTER

1. Insert safety ignition key (tied to recoil start cord) into ignition slot until it clicks. **DO NOT** turn the key. Keep the extra safety ignition key in a safe place.
2. Place throttle control in "FAST" position.
3. Place ON / OFF switch in "ON" position.
4. Rotate choke control to "FULL" position.
5. Push the primer three (3) times.

NOTE: Over priming may cause flooding, preventing the engine from starting. If you do flood the engine, wait a few minutes before attempting to start and **DO NOT** push the primer.

6. Pull recoil starter handle quickly. Do not allow starter rope to snap back.
7. When the engine starts, release the recoil starter handle and slowly move the choke control to the "OFF" position.

Allow the engine to warm up for a few minutes. Engine will not develop full power until it has reached normal operating temperature.

WARM START - RECOIL STARTER

Follow the steps above, keeping the choke in the "OFF" position. **DO NOT** push the primer.

BEFORE STOPPING

Run the engine for a few minutes to help dry off any moisture on the engine.

IF RECOIL STARTER HAS FROZEN

If the recoil starter has frozen and will not turn the engine, proceed as follows:

1. Grasp the recoil starter handle and slowly pull as much rope out of the starter as possible.
2. Release the recoil starter handle and let it snap back against the starter.

If the engine still fails to start, repeat the above steps or use the electric starter.

SNOW THROWING TIPS

- Always operate the snow thrower with the engine at full throttle. Full throttle offers the best performance.
- Go slower in deep, freezing or heavy wet snow. Use the drive speed control, **NOT** the throttle, to adjust speed.
- It is easier and more efficient to remove snow immediately after it falls.
- The best time to remove snow is the early morning. At this time the snow is usually dry and has not been exposed to the direct sun and warming temperatures.
- Slightly overlap each successive path to ensure all snow will be removed.
- Throw snow downwind whenever possible.
- Adjust the skid plates to proper height for current snow conditions. See "TO ADJUST SKID PLATES" in this section of this manual.
- For extremely heavy snow, reduce the width of snow removal by overlapping previous path and moving slowly.
- Keep engine clean and clear of snow during use. This will help air flow and extend engine life.
- After snow-throwing is completed, allow engine to run for a few minutes to melt snow and ice off the engine.
- Clean the entire snow thrower thoroughly after each use and wipe dry so it is ready for next use.



WARNING: Do not operate snow thrower if weather conditions impair visibility. Throwing snow during a heavy, windy snowstorm can blind you and be hazardous to the safe operation of the snow thrower.

MAINTENANCE

MAINTENANCE SCHEDULE								SERVICE DATES	
		BEFORE EACH USE	AFTER EACH USE	EVERY 25 HOURS OR EVERY SEASON	EVERY 50 HOURS	EVERY 100 HOURS	BEFORE STORAGE		
FILL IN DATES AS YOU COMPLETE REGULAR SERVICE									
T H R O W E R	Check for Loose Fasteners	✓					✓		
	Clean / Inspect Snow Thrower		✓				✓		
	Check / Replace V-Belts				✓				
	Lubrication Chart			✓			✓		
E N G I N E	Check Engine Oil Level	✓							
	Change Engine Oil			✓					
	Inspect Muffler				✓				
	Check / Replace Spark Plug					✓			
	Empty Fuel Tank						✓		

GENERAL RECOMMENDATIONS

The warranty on this snow thrower does not cover items that have been subjected to operator abuse or negligence. To receive full value from the warranty, operator must maintain snow thrower as instructed in this manual. Some adjustments will need to be made periodically to properly maintain your snow thrower.

All adjustments in the Service and Adjustments section of this manual should be checked at least once each season.

- Once a year, you should replace the spark plug and check belts for wear. A new spark plug will help your engine run better and last longer.
- Follow the maintenance schedule in this manual.

NOTE: Use only Original Equipment Manufacturer (OEM) parts to service this unit. Failure to do so can cause the unit to malfunction and pose a risk of injury to the operator.

BEFORE EACH USE

1. Check engine oil level.
2. Check for loose fasteners.
3. Check controls to be sure they are functioning properly.

LUBRICATION

Keep your snow thrower well lubricated (See "LUBRICATION CHART").

At the beginning of each season, or every 25 hours of use, apply a small amount of white lithium grease to the interlock bosses.

LUBRICATION CHART

- ① SAE 5w30 Motor Oil
- ② See "Engine" in Maintenance section
- ③ White Lithium Grease

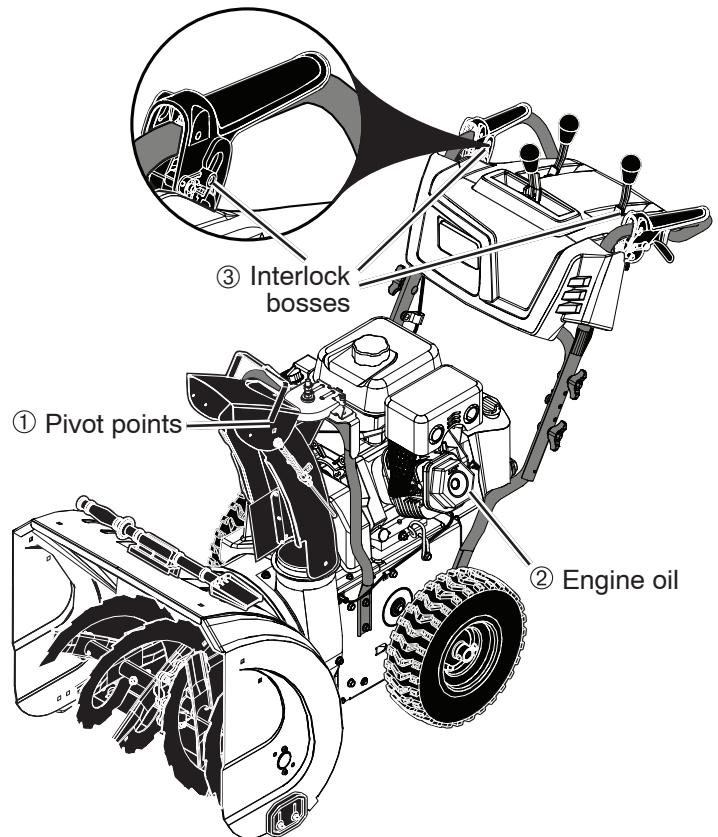

MAINTENANCE

SNOW THROWER

Always observe the safety rules when performing any maintenance.

TIRES

- Maintain proper air pressure in both tires (14–17 PSI).
- Keep tires free of gasoline and oil, which can harm rubber.

NOTE: To seal tire punctures and prevent flat tires due to slow leaks, tire sealant may be purchased from your local parts dealer. Tire sealant also prevents tire dry rot and corrosion.

BELTS

Check belts for deterioration and wear after every 50 hours of operation and replace if necessary. The belts are not adjustable. Replace belts if they begin to slip from wear. (See “TO REMOVE BELT COVER” in the Service and Adjustments section of this manual).

The belts on your snow thrower are of special construction and should be replaced by original equipment manufacturer (OEM) belts available from your nearest dealer. Using other than OEM belts can cause personal injury or damage to the snow thrower.

AUGER GEAR CASE

- The gear case was filled with lubricant to the proper level at the factory. The only time the lubricant needs attention is if service has been performed on the gear case.
- If lubricant is required, use only Ronex ED #1 grease.

TRACTION DRIVE SYSTEM

DO NOT lubricate the drive components inside the snow thrower. The sprockets, hex shafts, drive disc and friction wheel require no lubrication. The bearings and bushings are lifetime lubricated and require no maintenance.

CAUTION: Any lubricating of the above components can cause contamination of the friction wheel and damage to the drive system of your snow thrower.

ENGINE

See engine manual.

LUBRICATION

Use only high quality detergent oil rated with API service classification SG–SL. Select the oil's SAE viscosity grade according to your expected operating temperature.

SAE VISCOSITY GRADES	
	5W30 or 10W30
	Synthetic 5W30 or 10W30
°F	-20 0 30 32 40
°C	-30 -20 -10 0 10
TEMPERATURE RANGE ANTICIPATED BEFORE NEXT OIL CHANGE	

NOTE: Although multi-viscosity oils (5W30, 10W30 etc.) improve starting in cold weather, these multi-viscosity oils will result in increased oil consumption when used above 32°F. Check your engine oil level more frequently to avoid possible engine damage from running low on oil.

Change the oil after every 25 hours of operation or at least once a year if the snow thrower is not used for 25 hours in one year.

Check the crankcase oil level before starting the engine and after each five (5) hours of continuous use. Tighten oil fill cap / dipstick securely each time you check the oil level.

TO CHANGE ENGINE OIL

Determine temperature range anticipated before next oil change. All oil must meet API service classification SG–SL.

- Be sure snow thrower is on level surface.
- Oil will drain more freely when warm.
- Catch oil in a suitable container.

NOTE: A wheel may be removed from snow thrower for easier access to the oil drain plug and placement of a suitable container.

1. Remove safety ignition key and disconnect spark plug wire from spark plug. Place wire where it cannot come in contact with spark plug.
2. Clean area around drain plug.
3. Remove drain plug and drain oil in a suitable container.
4. Install drain plug and tighten securely.
5. Wipe off any spilled oil from snow thrower and engine.
6. Install left wheel (if removed for draining oil). Be sure to install wheel pin and retainer pin into proper hole in wheel axle (See “TO REMOVE WHEELS” in the Service and Adjustments section of this manual).
7. Remove oil fill cap/dipstick. Be careful not to allow dirt to enter the engine.
8. Refill engine with oil through oil dipstick tube. Pour slowly. Do not overfill. For approximate capacity see “PRODUCT SPECIFICATIONS” section of this manual.
9. Use gauge on oil fill cap/dipstick for checking level. Be sure dipstick cap is tightened securely for accurate reading. Keep oil at “FULL” line on dipstick.
10. Wipe off any spilled oil.

MUFFLER

Inspect and replace corroded muffler as it could create a fire hazard and/or damage.

SPARK PLUG

Replace spark plug at the beginning of each season or after every 100 hours of operation, whichever occurs first. Spark plug type and gap setting are shown in the “PRODUCT SPECIFICATIONS” section of this manual.

CLEANING

IMPORTANT: For best performance, keep snow thrower housing free of any dirt or trash. Clean the outside of your snow thrower after each use.



WARNING: Remove safety ignition key and disconnect spark plug wire from spark plug. Place wire where it cannot come in contact with spark plug.

- Keep finished surfaces/wheels free of gasoline, oil, etc.
- We do not recommend using a garden hose to clean your snow thrower unless the electrical system, muffler and carburetor are covered to keep water out. Water in engine can result in shortened engine life.

SERVICE AND ADJUSTMENTS

WARNING: To avoid serious injury, before performing any service or adjustments:



1. Be sure the on/off switch is in the OFF position.
2. Remove safety ignition key.
3. Make sure the augers and all moving parts have completely stopped.
4. Disconnect spark plug wire from spark plug and place wire where it cannot come in contact with plug.

SNOW THROWER

TO ADJUST SNOW THROWER HEIGHT

See "TO ADJUST SKID PLATES" and "SCRAPER BAR" in the Operation section of this manual.

CHUTE DEFLECTOR

The chute deflector, attached to the top of the discharge chute, is provided to direct discharging snow away from the operator. If the deflector becomes damaged, it should be replaced.



WARNING: To avoid serious injury, never operate your snow thrower with the deflector removed or damaged.

- To change direction and/or distance snow is discharged, see "TO CONTROL SNOW DISCHARGE" in the Operation section of this manual.

SHEAR BOLTS (See Fig. 18)

AUGER SHEAR BOLTS

Both right and left-hand augers are secured to the auger shaft with a shear bolt and hex nut. Should a foreign object or ice become lodged in the augers, the shear bolts are designed to break, preventing damage to any other components. If one or both augers do not turn when auger control lever is engaged, check to see if one or both of the bolts have sheared. To replace the shear bolts:

1. Disengage all controls and move throttle control to STOP position. Wait for all moving parts to stop.
2. Remove safety ignition key and disconnect spark plug wire from spark plug. Place wire where it cannot come in contact with spark plug.
3. Align hole in auger hub with hole in auger shaft and install a new 1/4-20 shear bolt. Install 1/4-20 lock nut and tighten securely.

CAUTION: Do not substitute. Use only original equipment shear bolts as supplied with your snow thrower.

4. Insert safety ignition key and reconnect spark plug wire to spark plug.

IMPELLER SHEAR BOLTS

The impeller is secured to the impeller shaft with two (2) shear bolts and hex nuts. Should a foreign object or ice become lodged in the impeller, the shear bolts are designed to break, preventing damage to any other components. If impeller does not turn when auger control lever is engaged, check to see if the shear bolts have sheared.

To replace the shear bolts:

1. Disengage all controls and move throttle control to STOP position. Wait for all moving parts to stop.
2. Remove safety ignition key and disconnect spark plug wire from spark plug. Place wire where it cannot come in contact with spark plug.
3. Align holes in impeller hub with holes in impeller shaft and install two (2) new 2" shear bolts. Install 1/4-20 locknuts and tighten securely.

CAUTION: Do not substitute. Use only original equipment capscrew/shear bolts as supplied with your snow thrower.

4. Insert safety ignition key and reconnect spark plug wire to spark plug.

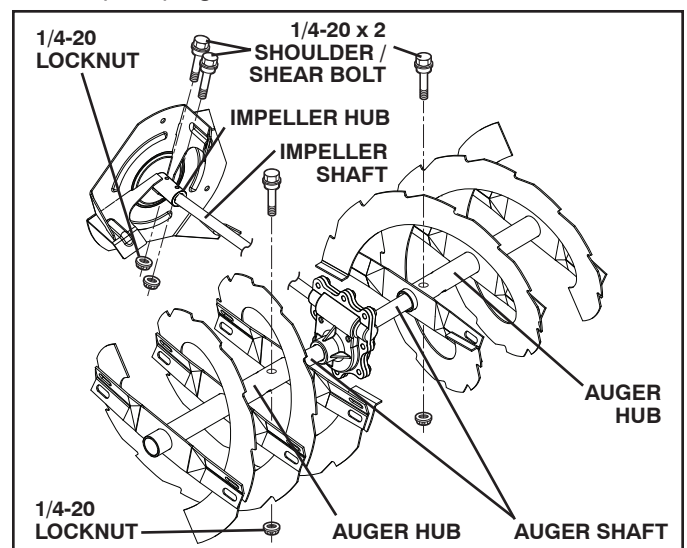

FIG. 18

TO REMOVE BELT COVER (See Fig. 19)

1. Loosen the two (2) screws securing belt cover to frame.
 2. Remove belt cover.
- Replace belt cover by installing cover and tightening screws.

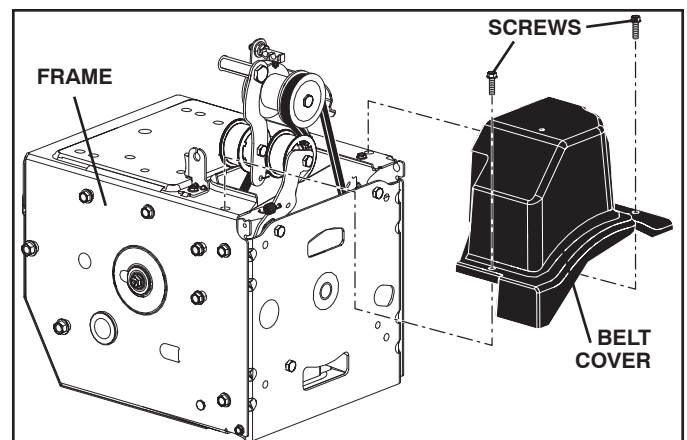

FIG. 19

SERVICE AND ADJUSTMENTS

TO REPLACE BELTS

The auger and traction drive belts are not adjustable. If the belts are damaged or begin to slip from wear, they should be replaced. It is recommended that the belt(s) be replaced by a service center/department.

NOTE: It is recommended that both the auger and traction drive belt be replaced at the same time.

The V-belts on your snow thrower are of special construction and should be replaced by original equipment manufacturer (OEM) belts available from your nearest service center/department. Using other than OEM belts can cause personal injury or damage to the snow thrower.



WARNING: Belt replacement requires separation of the snow thrower. While separating the auger housing from the frame assembly, it is important that an assistant stand in the operating position and hold the snow thrower handles. Serious personal injury and/or damage to the unit could occur if the snow thrower should fall during the belt changing process.

BEFORE REPLACING BELTS

1. REMOVE GASOLINE FROM FUEL TANK - Drain gasoline from fuel tank into a suitable container, outdoors, away from fire or flame. Wipe up any spilled gasoline.
2. REMOVE DISCHARGE CHUTE - Remove lock nut securing chute rotator head to mounting bracket to allow chute rotator head to be raised and discharge chute to be removed from snow thrower. See Fig. 20.

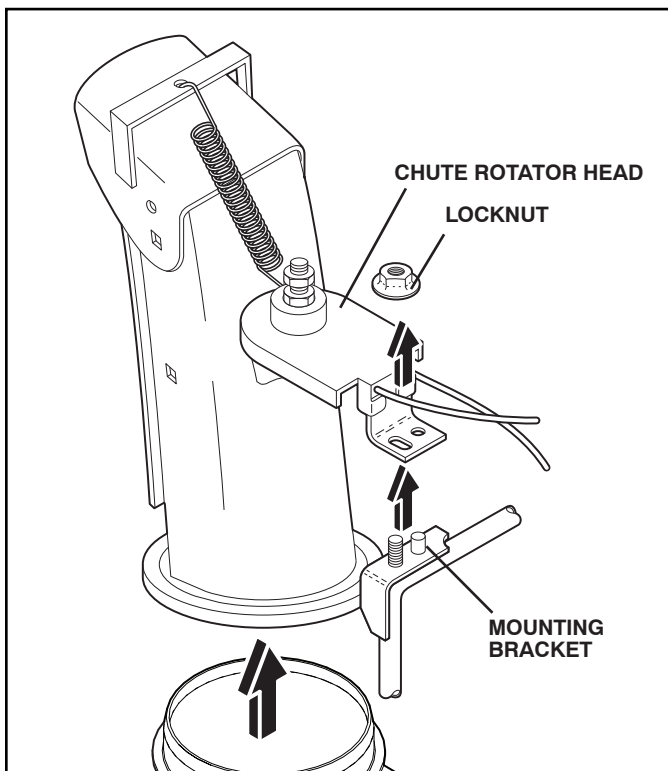

FIG. 20

3. REMOVE BELT COVER - See "TO REMOVE BELT COVER" in this section of this manual.

AUGER BELT REPLACEMENT (See Fig. 21)

TO REMOVE AUGER BELT

1. Remove upper 5/16" bolts and lower 1/4" bolts from both sides of the frame assembly. Do not discard bolts.
2. Loosen but DO NOT REMOVE lower 5/16" bolts on both sides of the frame assembly.
3. Remove the auger belt from the engine pulley.
4. Tip the back section down. The front section will tip forward at the same time, as the bottom bolt acts as a hinge between the front and back sections. Use a block under the hinge point to secure the snow thrower in the tipped position as shown.
5. Move auger belt tensioner arm and remove auger belt from around the arm.

TO INSTALL AUGER BELT

1. Move belt tensioner arm and place auger belt around and inside groove of the auger pulley.

NOTE: Ensure the belt is not pinched between the frame and auger housing as you bring the unit back together.

2. Remove block from under the snow thrower. Lift the handles to tip the back section up. The front section will tip back and pivot to rejoin the back section.
3. Ensure belt is routed inside auger pulley groove properly.
4. Install the previously removed and loosened 5/16" bolts, and tighten securely. (8-12 Ft. Lbs. / 11-16 Nm).
Install the previously removed 1/4" bolts, and tighten securely. (4-6 Ft. Lbs. / 5-8 Nm).
5. Install auger belt onto engine pulley. Ensure belt is routed correctly around idler pulley and seated properly in engine pulley groove.
6. Operate all controls to ensure belts are installed properly and that all components are moving correctly.

Continue with "AFTER REPLACING BELTS" instructions.

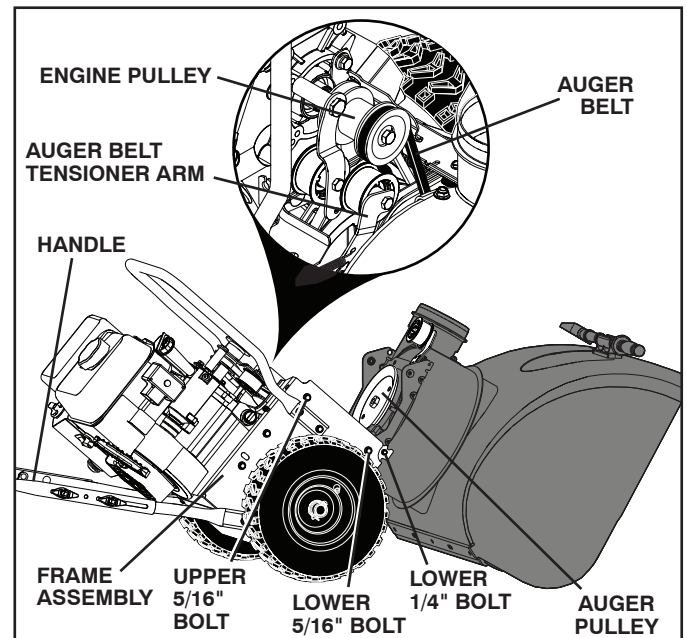

FIG. 21

SERVICE AND ADJUSTMENTS

DRIVE BELT REPLACEMENT (See Fig. 22)

TO REMOVE DRIVE BELT

1. Remove auger belt. See "TO REMOVE AUGER BELT" in this section.
2. Remove tensioner spring attached to drive belt tensioner arm.
3. Remove return spring holding the swing plate in place.
4. Remove arm bolt and drive belt tensioner arm.
5. Remove pulley bolt, engine pulley, and drive belt from engine.
6. Remove the top bolt holding the swing plate to frame assembly.
7. Pivot and hold the swing plate away from snow thrower and remove drive belt from drive pulley.

TO INSTALL DRIVE BELT

1. Pivot and hold swing plate away from snow thrower. Place drive belt onto drive pulley. Ensure drive belt is routed in drive pulley groove properly before lowering swing plate.
2. Install previously removed top bolt. Tighten securely.
3. Place drive belt into engine pulley groove before installing onto engine shaft.
4. Install previously removed pulley bolt and secure engine pulley onto engine. Tighten securely (30-35 Ft. Lbs. / 41-47 Nm).
5. Install drive belt tensioner arm and arm bolt onto engine. Tighten securely.
6. Install return spring onto swing plate.
7. Install tensioner spring onto tensioner arm.
8. Operate all controls to ensure belts are installed properly and that all components are moving correctly.
9. Install auger belt. See "TO INSTALL AUGER BELT" in this section.

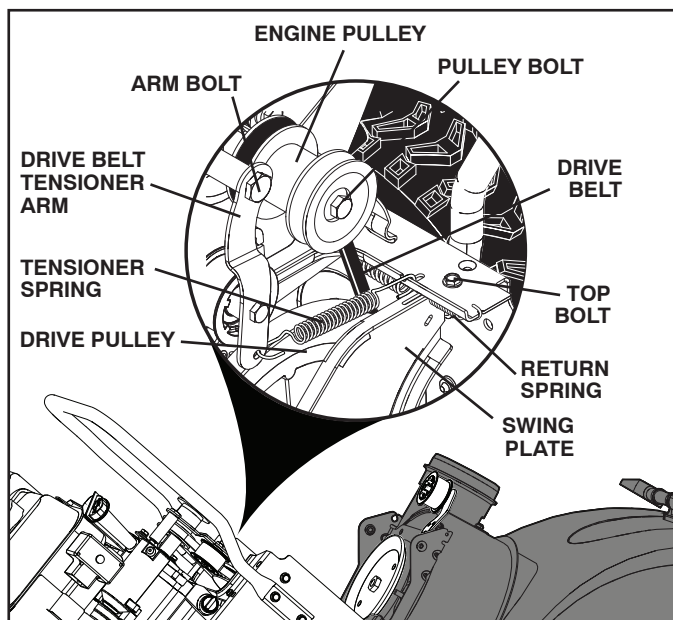

FIG. 22

AFTER REPLACING BELT(S)

1. INSTALL BELT COVER and two (2) screws. Tighten securely.
2. INSTALL DISCHARGE CHUTE – See "INSTALL DISCHARGE CHUTE / CHUTE ROTATER HEAD" in the Assembly section of this manual.

TO REMOVE WHEELS (See Fig. 23)

- Remove the wheel pin and retainer pin and remove wheel from axle.

NOTE: To seal punctures or prevent flat tires due to slow leaks, tire sealant may be purchased from your local parts dealer. Tire sealant also prevents tire dry rot and corrosion.

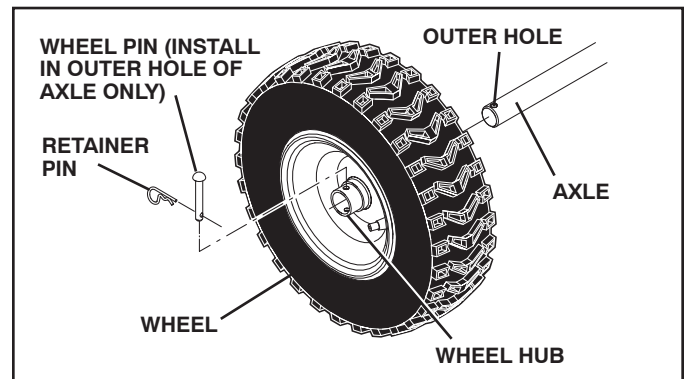

FIG. 23

ENGINE

SEE ENGINE MANUAL

CARBURETOR

Your carburetor is not adjustable. Engine performance should not be affected at altitudes up to 2,134 meters. If your engine does not operate properly due to suspected carburetor problems, take your snow thrower to a service center/department.

ENGINE SPEED

Never tamper with the engine governor, which is factory set for proper engine speed. Overspeeding the engine above the factory high speed setting can be dangerous and will void the warranty. If you think the engine-governed high speed needs adjusting, contact a service center/department, which has the proper equipment and experience to make any necessary adjustments.

STORAGE

Immediately prepare your snow thrower for storage at the end of the season or if the unit will not be used for 30 days or more.



WARNING: Never store the snow thrower with gasoline in the tank inside a building where fumes may reach an open flame, spark or pilot light as on a furnace, water heater, clothes dryer or gas appliance. Allow the engine to cool before storing in any enclosure.

SNOW THROWER

When snow thrower is to be stored for a period of time, clean it thoroughly, remove all dirt, grease, leaves, etc. Store in a clean, dry area.

1. Clean entire snow thrower (See “CLEANING” in the Maintenance section of this manual).
2. Inspect and replace belts, if necessary (See “TO REPLACE BELTS” in the Service and Adjustments section of this manual).
3. Lubricate as shown in the Maintenance section of this manual.
4. Be sure that all nuts, bolts, screws, and pins are securely fastened. Inspect moving parts for damage, breakage and wear. Replace if necessary.
5. Touch up all rusted or chipped paint surfaces; sand lightly before painting.

ENGINE

See engine manual.

FUEL SYSTEM

IMPORTANT: It is important to prevent gum deposits from forming in essential fuel system parts such as carburetor, fuel hose, or tank during storage. Also, alcohol blended fuels (called gasohol or using ethanol or methanol) can attract moisture which leads to separation and formation of acids during storage. Acidic gas can damage the fuel system of an engine while in storage.

- Empty the fuel tank by starting the engine and letting it run until the fuel lines and carburetor are empty.
- Never use engine or carburetor cleaner products in the fuel tank or permanent damage may occur.
- Use fresh fuel next season.

NOTE: Fuel stabilizer is an acceptable alternative in minimizing the formation of fuel gum deposits during storage. Add stabilizer to gasoline in fuel tank or storage container. Always follow the mix ratio found on stabilizer container. Run engine at least 10 minutes after adding stabilizer to allow the stabilizer to reach the carburetor. Do not drain the gas tank and carburetor if using fuel stabilizer.

ENGINE OIL

Drain oil (with engine warm) and replace with clean engine oil. (See “ENGINE” in the Maintenance section of this manual).

CYLINDER

1. Remove spark plug.
2. Pour one ounce (29 ml) of oil through spark plug hole into cylinder.
3. Pull recoil starter handle slowly a few times to distribute oil.
4. Replace with new spark plug.

OTHER

- Remove safety ignition key; store it in a safe place.
- Do not store gasoline from one season to another.
- Replace your gasoline can if your can starts to rust. Rust and/or dirt in your gasoline will cause problems.
- If possible, store your snow thrower indoors and cover it to protect it from dust and dirt.
- Cover your snow thrower with a suitable protective cover that does not retain moisture. Do not use plastic. Plastic cannot breathe, which allows condensation to form and will cause your snow thrower to rust.

IMPORTANT: Never cover snow thrower while engine/exhaust area is still warm.

TROUBLESHOOTING

See appropriate section in manual unless directed to an authorized service center/department.

PROBLEM	CAUSE	CORRECTION
Does not start	<ol style="list-style-type: none"> 1. Fuel shut-off valve (if so equipped) in OFF position. 2. Safety ignition key is not inserted. 3. Out of fuel. 4. Throttle in STOP position (or ON/OFF switch is OFF). 5. Choke in OFF position. 6. Primer not depressed. 7. Engine is flooded. 8. Spark plug wire is disconnected. 9. Bad spark plug. 10. Stale fuel. 11. Water in fuel. 	<ol style="list-style-type: none"> 1. Turn fuel shut-off valve to OPEN position. 2. Insert safety ignition key. 3. Fill fuel tank with fresh, clean gasoline. 4. Move throttle to FAST position (or ON/OFF switch to ON position). 5. Move to FULL position. 6. Prime as instructed in the Operation section of this manual. 7. Wait a few minutes before restarting, DO NOT prime. 8. Connect wire to spark plug. 9. Replace spark plug. 10. Empty fuel tank & carburetor, refill with fresh, clean gasoline. 11. Empty fuel tank & carburetor, refill with fresh, clean gasoline.
Loss of power	<ol style="list-style-type: none"> 1. Spark plug wire loose. 2. Throwing too much snow. 3. Fuel tank cap is covered with ice or snow. 4. Dirty or clogged muffler. 	<ol style="list-style-type: none"> 1. Reconnect spark plug wire. 2. Reduce speed and width of swath. 3. Remove ice and snow on and around fuel tank cap. 4. Clean or replace muffler.
Engine idles or runs roughly	<ol style="list-style-type: none"> 1. Choke is in FULL position. 2. Blockage in fuel line. 3. Stale fuel. 4. Water in fuel. 5. Carburetor is in need of adjustment or overhaul. 	<ol style="list-style-type: none"> 1. Move choke to OFF position. 2. Clean fuel line. 3. Empty fuel tank & carburetor, refill with fresh, clean gasoline. 4. Empty fuel tank & carburetor, refill with fresh, clean gasoline. 5. Contact an authorized service center/department.
Excessive vibration	<ol style="list-style-type: none"> 1. Loose parts or damaged augers or impeller. 	<ol style="list-style-type: none"> 1. Tighten all fasteners. Replace damaged parts. If vibration remains, contact an authorized service center/department.
Recoil starter is hard to pull	<ol style="list-style-type: none"> 1. Frozen recoil starter. 	<ol style="list-style-type: none"> 1. See "IF RECOIL STARTER HAS FROZEN" in the Operation section of this manual.
Loss of traction drive / slowing of drive speed	<ol style="list-style-type: none"> 1. Drive belt is off of pulley. 2. Friction drive wheel is worn. 	<ol style="list-style-type: none"> 1. Check / reinstall drive belt. 2. Contact an authorized service center/department.
Loss of snow discharge or slowing of snow discharge	<ol style="list-style-type: none"> 1. Auger belt is off of pulley. 2. Auger belt is worn. 3. Clogged discharge chute. 4. Augers / impeller jammed. 	<ol style="list-style-type: none"> 1. Check / reinstall auger belt. 2. Check / replace auger belt. 3. Clean snow chute. 4. Remove debris or foreign object from augers / impeller.

SERVICE NOTES

REPAIR PARTS

SNOW THROWER - - MODEL NUMBER 944.525431

AUGER HOUSING / IMPELLER ASSEMBLY

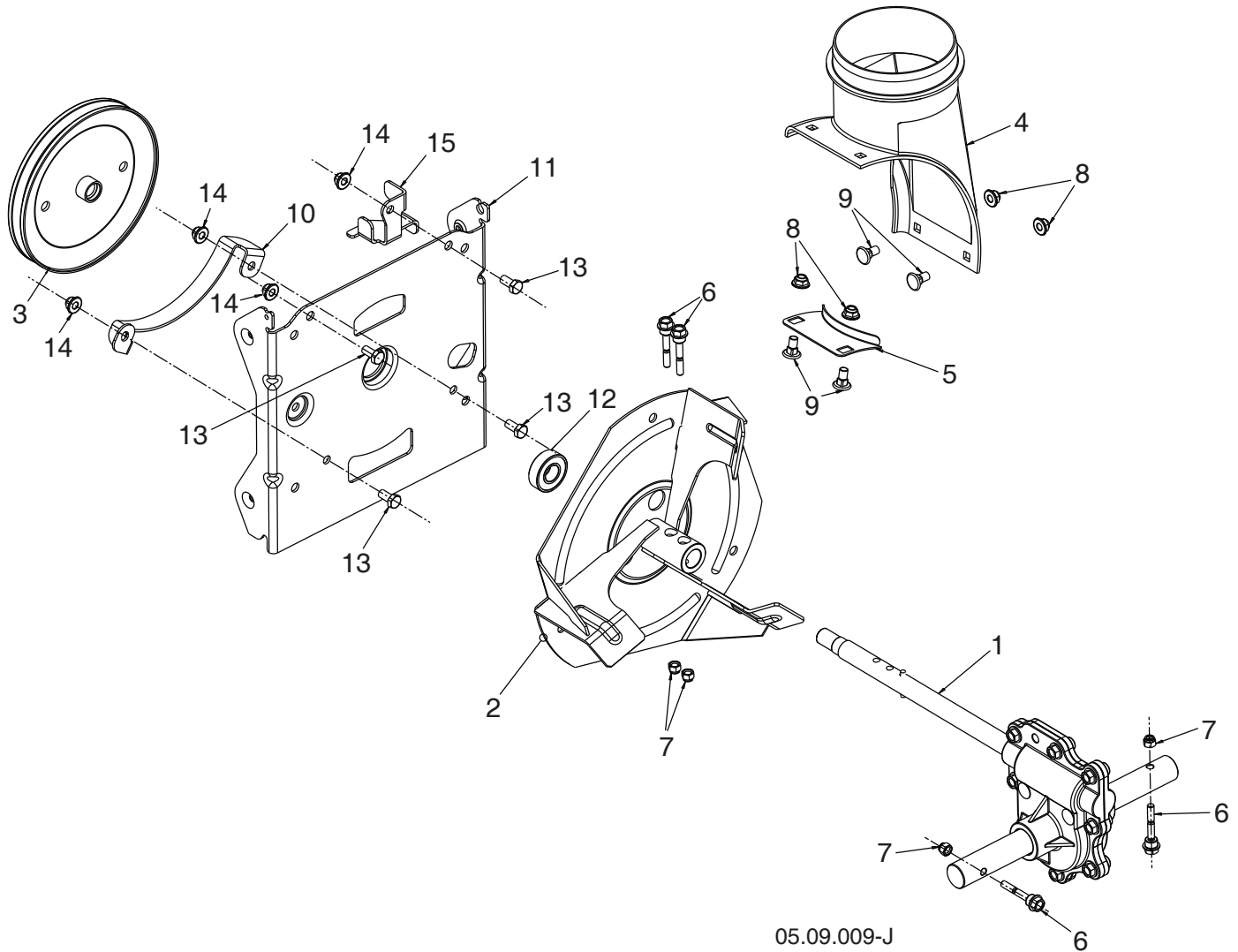

05.09.009-J

NOTE: All component dimensions given in U.S. inches. 1 inch = 25.4 mm
IMPORTANT: Use only Original Equipment Manufacturer (O.E.M.) replacement parts.
Failure to do so could be hazardous, damage your snow thrower and void your warranty.

REPAIR PARTS**SNOW THROWER - - MODEL NUMBER 944.525431****AUGER HOUSING / IMPELLER ASSEMBLY**

KEY NO.	PART NO.	DESCRIPTION
1	501149601	GEARBOX AUGER
2	586607202	IMPELLER STEEL
3	587402401	PULLEY IMPELLER – SCREW ON
4	585056901	CHUTE DISCHARGE BASE
5	178675	BRACKET CORNER DISCHARGE BASE
6	588077501	BOLT SHEAR 1/4-20
7	73800400	NUT NYLOCK 1/4-20
8	585691301	NUT FLANGE NYLOCK 5/16-18 - BLK
9	585691201	BOLT CARRIAGE WAFER HEAD 5/16-18 X 5/8 BLK
10	581632002	BRACKET BELT KEEPER LOWER
11	581592502	BRACKET INTERFACE
12	198791	BEARING BALL
13	163183	SCREW HEX HEAD 5/16-18 X 5/8
14	427942	NUT FLANGE NYLOCK 5/16-18
15	587587202	LOWER AUGER BELT GUIDE

NOTE: All component dimensions given in U.S. inches. 1 inch = 25.4 mm

IMPORTANT: Use only Original Equipment Manufacturer (O.E.M.) replacement parts. Failure to do so could be hazardous, damage your snow thrower and void your warranty.

REPAIR PARTS

SNOW THROWER - - MODEL NUMBER 944.525431

AUGER HOUSING / IMPELLER ASSEMBLY

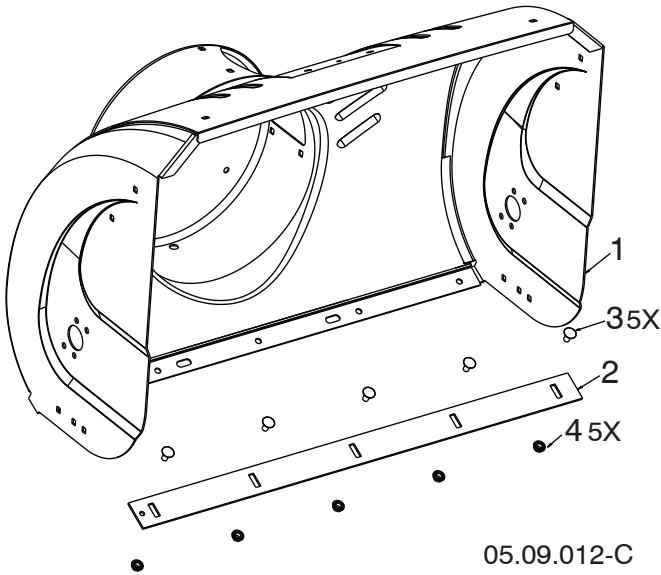

KEY NO.	PART NO.	DESCRIPTION
1	588610227	AUGER HOUSING
2	404933X479	SCRAPER BAR
3	72270505	CARRIAGE BOLT 5/16-18 X .625 GR5
4	155377	NUT 5/16-18

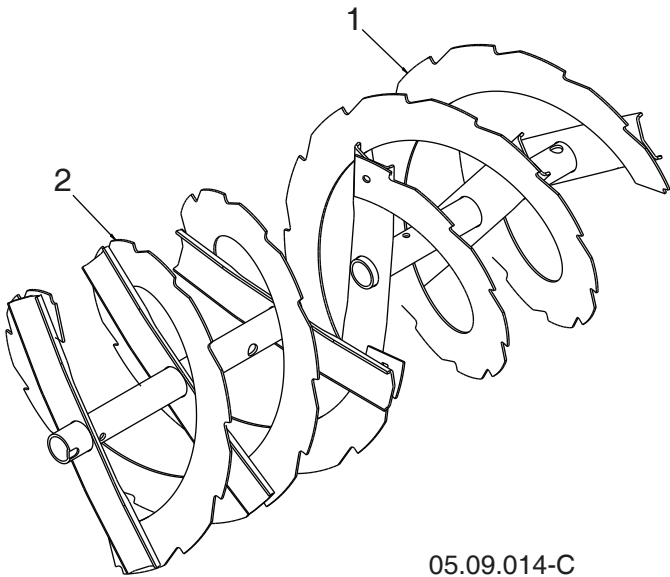

KEY NO.	PART NO.	DESCRIPTION
1	420497X479	AUGER ASSEMBLY 30 LH
2	420498X479	AUGER ASSEMBLY 30 RH

NOTE: All component dimensions given in U.S. inches. 1 inch = 25.4 mm
IMPORTANT: Use only Original Equipment Manufacturer (O.E.M.) replacement parts.
 Failure to do so could be hazardous, damage your snow thrower and void your warranty.

REPAIR PARTS

SNOW THROWER - - MODEL NUMBER 944.525431

AUGER HOUSING / IMPELLER ASSEMBLY

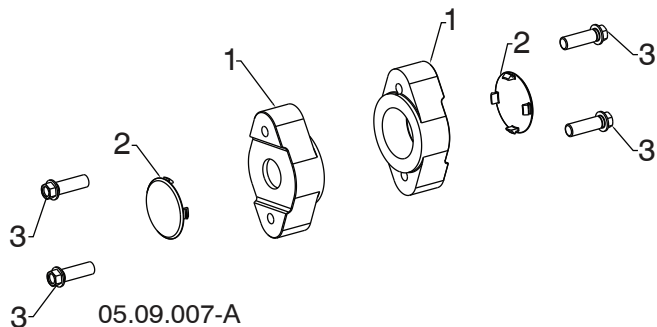

KEY NO.	PART NO.	DESCRIPTION
1	420478	AUGER BEARING
2	411939	BEARING PLUG
3	584299401	SCREW HI-LO WASHD 5/16-14 X 1.00

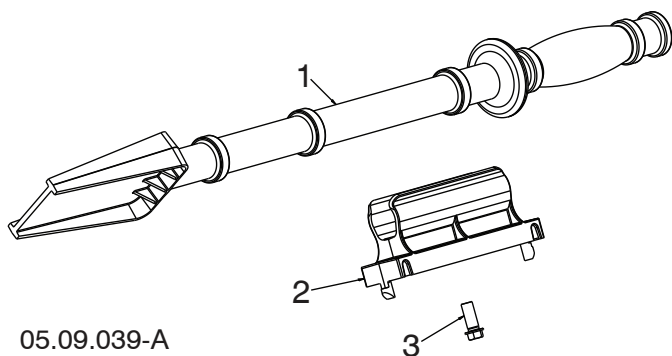

KEY NO.	PART NO.	DESCRIPTION
1	192199	TOOL CLEANOUT
2	405400	CLIP CLEANOUT TOOL
3	194189	SCREW HEX WASHER 13-16 X 5/8

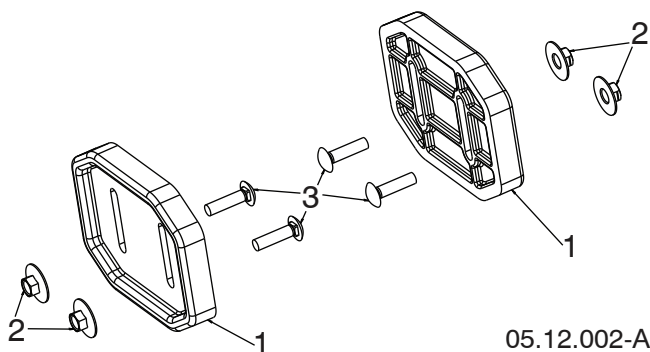

KEY NO.	PART NO.	DESCRIPTION
1	435951	PLATE SKID PLASTIC HDPE
2	585802801	NUT LARGE FLANGE 5/16-18 BLK
3	585802901	BOLT CARRIAGE 5/16-18 X 1.25 – BLK

NOTE: All component dimensions given in U.S. inches. 1 inch = 25.4 mm
IMPORTANT: Use only Original Equipment Manufacturer (O.E.M.) replacement parts.
 Failure to do so could be hazardous, damage your snow thrower and void your warranty.

REPAIR PARTS

SNOW THROWER - - MODEL NUMBER 944.525431

CONTROL PANEL / DISCHARGE CHUTE

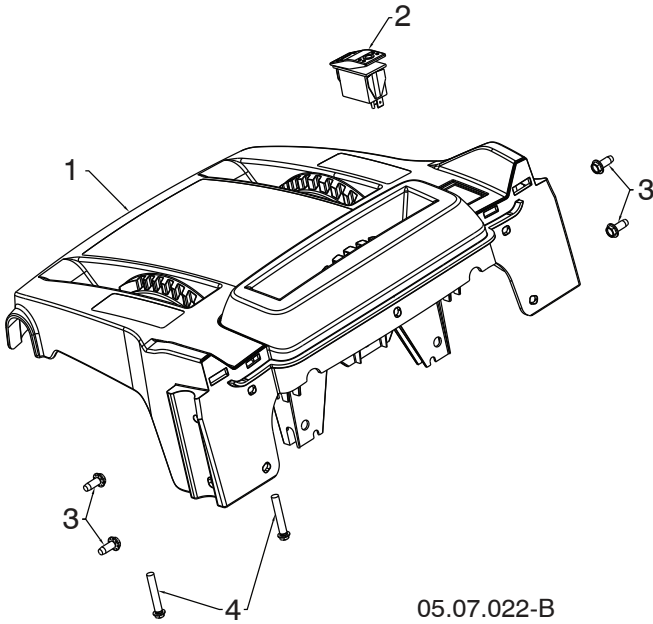

05.07.022-B

KEY NO.	PART NO.	DESCRIPTION
1	588925902	CONSOLE BASE MULTICONT W/SWITCH
2	585805001	SWITCH GRIP HEATED BLACK
3	17060410	SCREW TA SEMI GIMLE 1/4-20 X .62
4	581329501	SCREW HEX WASHER 13-16 X 1.50

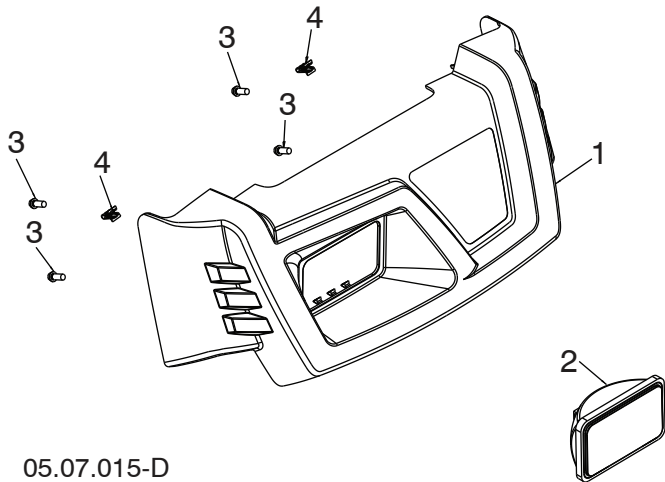

05.07.015-D

KEY NO.	PART NO.	DESCRIPTION
1	581128111	CONSOLE COVER CRAFTSMAN
2	586181001	FLOOD LIGHT
3	194189	SCREW HI-LO 13-16 X 5/8
4	581928701	PANEL CLIP
--	183784	BULB (NOT SHOWN)

NOTE: All component dimensions given in U.S. inches. 1 inch = 25.4 mm
IMPORTANT: Use only Original Equipment Manufacturer (O.E.M.) replacement parts. Failure to do so could be hazardous, damage your snow thrower and void your warranty.

REPAIR PARTS

SNOW THROWER - - MODEL NUMBER 944.525431

CONTROL PANEL / DISCHARGE CHUTE

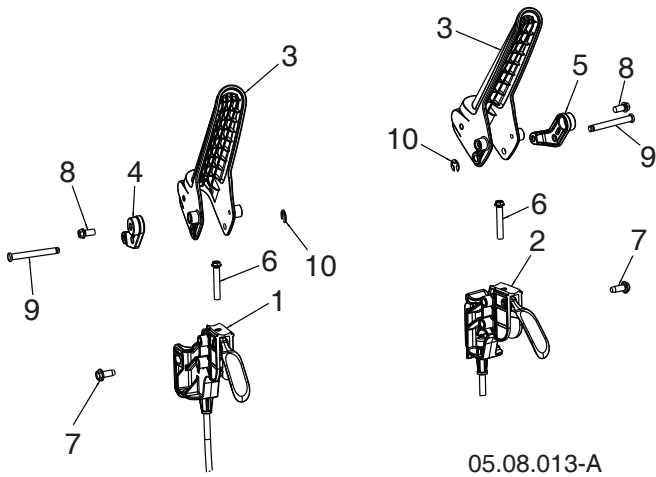

KEY NO.	PART NO.	DESCRIPTION
1	588263901	CABLE, POWER STEER - LHS
2	588263902	CABLE, POWER STEER - RHS
3	587463001	LEVER, CONTROL
4	587739701	LEVER, CABLE ARM - LHS
5	587739702	LEVER, CABLE ARM - RHS
6	581329501	SCREW HI-LO 13-16 X 1.50
7	17060410	SCREW 1/4-20 X .625
8	17411308	SCREW HI-LW 13-16 X .500
9	588147701	PIN, GROOVED
10	12000014	E-RING

05.08.013-A

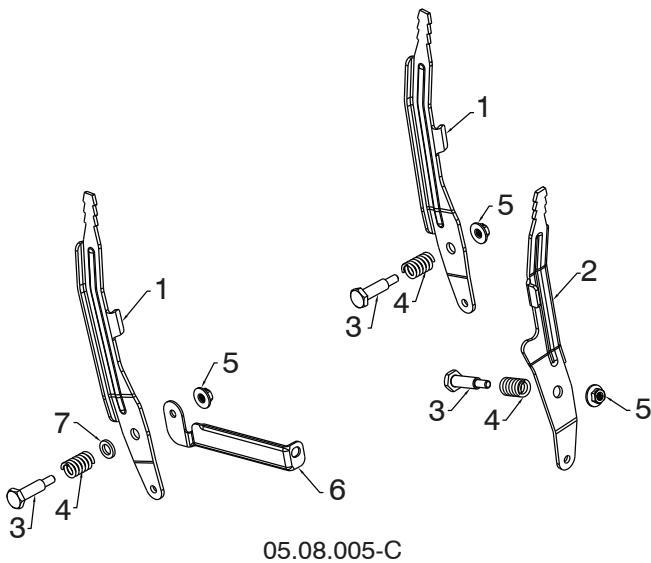

KEY NO.	PART NO.	DESCRIPTION
1	581123902	LEVER CONTROL SPEED/DEFL
2	581241602	LEVER CONTROL CHUTE ROT
3	581329701	BOLT SHOULDER 1/4-20
4	581329601	SPRING COMPRESSION
5	586668901	NUT FL LOCK 1/4-20
6	584468402	BRACE SUPPORT SPEED
7	587031301	WASHER .625 X .375 X .094 NYLON 6/6

05.08.005-C

NOTE: All component dimensions given in U.S. inches. 1 inch = 25.4 mm
IMPORTANT: Use only Original Equipment Manufacturer (O.E.M.) replacement parts.
 Failure to do so could be hazardous, damage your snow thrower and void your warranty.

REPAIR PARTS

SNOW THROWER - - MODEL NUMBER 944.525431

CONTROL PANEL / DISCHARGE CHUTE

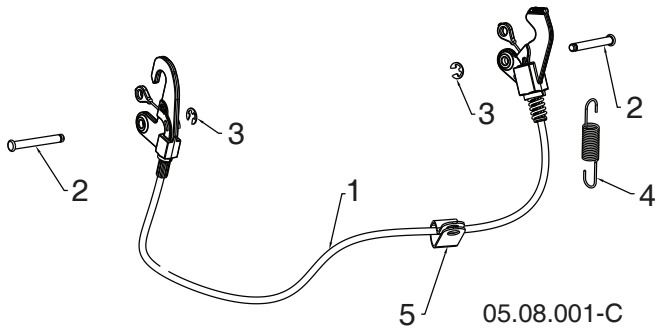

KEY NO.	PART NO.	DESCRIPTION
1	587332502	CABLE INTERLOCK
2	431762	PIN GROOVED
3	12000014	E-RING
4	581151201	SPRING RETURN
5	197991	CLIP CABLE BLACK

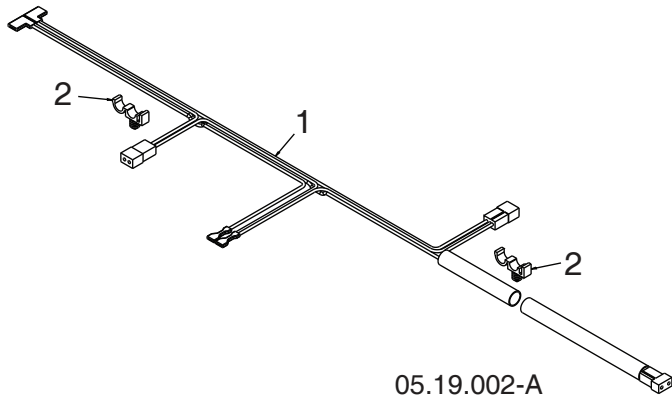

KEY NO.	PART NO.	DESCRIPTION
1	587535701	HARNESS WIRE LIGHTS & GRIPS
2	145006	WIRE RETAINER

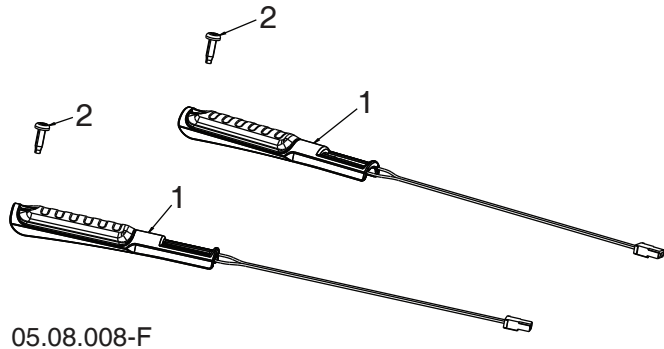

KEY NO.	PART NO.	DESCRIPTION
1	588775901	GRIP HANDLE HEATED
2	442250	SCREW PAN HD TORX 1/4-20 X .75

NOTE: All component dimensions given in U.S. inches. 1 inch = 25.4 mm
IMPORTANT: Use only Original Equipment Manufacturer (O.E.M.) replacement parts.
 Failure to do so could be hazardous, damage your snow thrower and void your warranty.

REPAIR PARTS

SNOW THROWER - - MODEL NUMBER 944.525431

CONTROL PANEL / DISCHARGE CHUTE

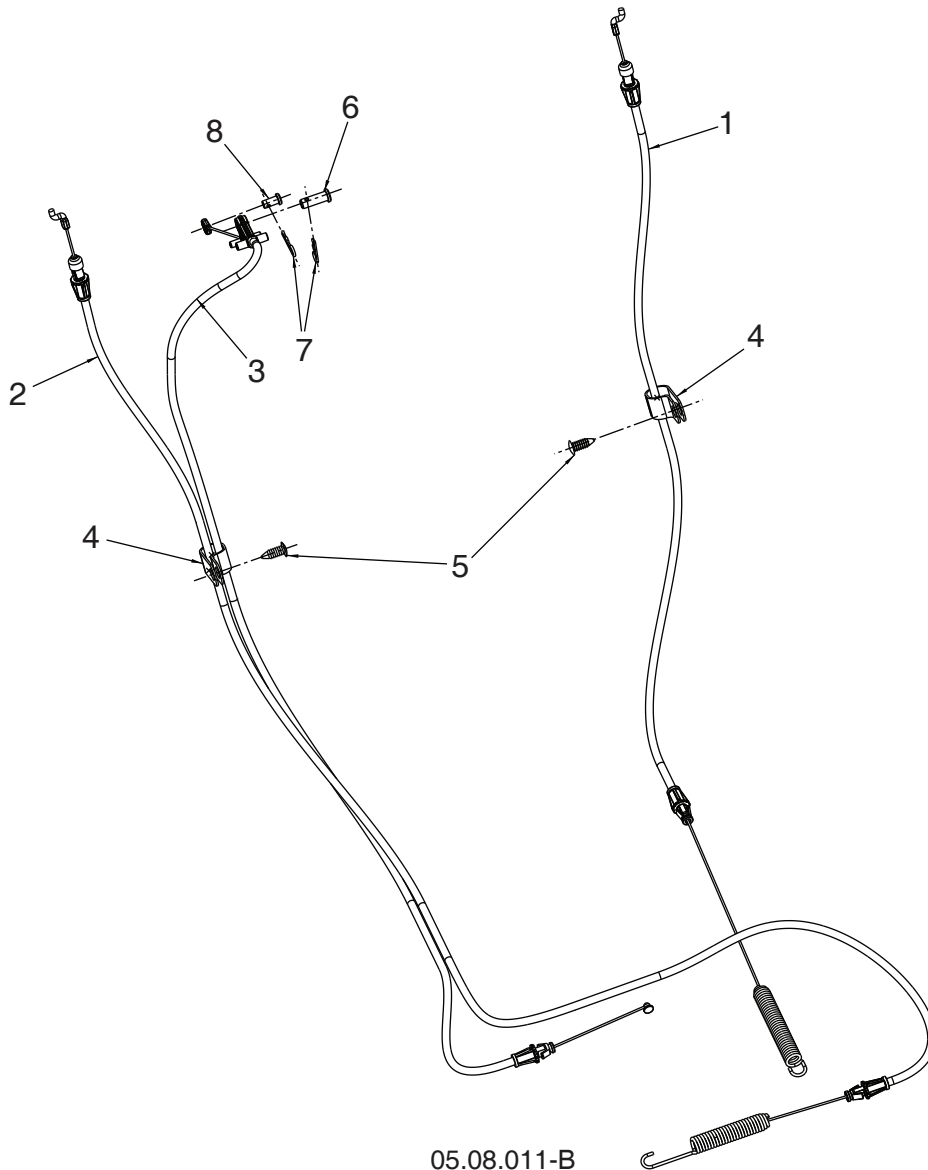

05.08.011-B

KEY NO.	PART NO.	DESCRIPTION
1	588113702	CABLE CONTROL DRIVE
2	588113801	CABLE CONTROL AUGER
3	588122301	CABLE CONTROL SPEED
4	197991	CLIP CABLE
5	428124	FASTENER PUSH .250
6	581329401	PIN CLEVIS 5/16
7	423303	HAIRPIN
8	585808301	PIN CLEVIS 1/4

NOTE: All component dimensions given in U.S. inches. 1 inch = 25.4 mm
IMPORTANT: Use only Original Equipment Manufacturer (O.E.M.) replacement parts.
Failure to do so could be hazardous, damage your snow thrower and void your warranty.

REPAIR PARTS

SNOW THROWER - - MODEL NUMBER 944.525431

CONTROL PANEL / DISCHARGE CHUTE

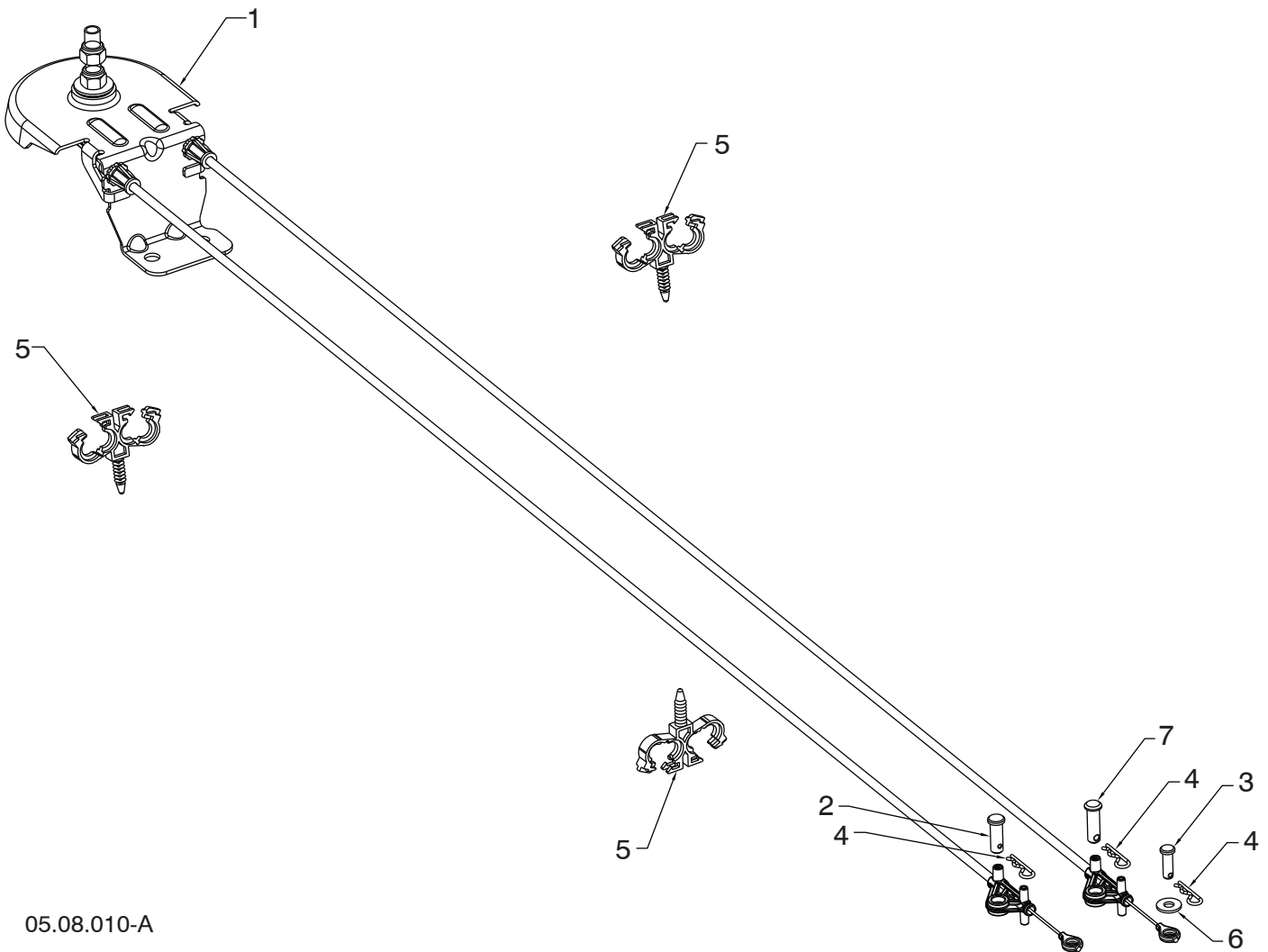

05.08.010-A

KEY NO.	PART NO.	DESCRIPTION
1	587803401	CABLE CHUTE ROTATOR ASM
2	581329401	PIN CLEVIS 5/6 X 7/8
3	77100812	PIN CLEVIS 1/4 X 3/4
4	423303	HAIRPIN SOFT ZINC
5	584652201	CLIP CONDUIT DOUBLE
6	586682101	WASHER
7	587130801	PIN CLEVIS 5/16 X 1

NOTE: All component dimensions given in U.S. inches. 1 inch = 25.4 mm
IMPORTANT: Use only Original Equipment Manufacturer (O.E.M.) replacement parts.
 Failure to do so could be hazardous, damage your snow thrower and void your warranty.

REPAIR PARTS

SNOW THROWER - - MODEL NUMBER 944.525431

CONTROL PANEL / DISCHARGE CHUTE

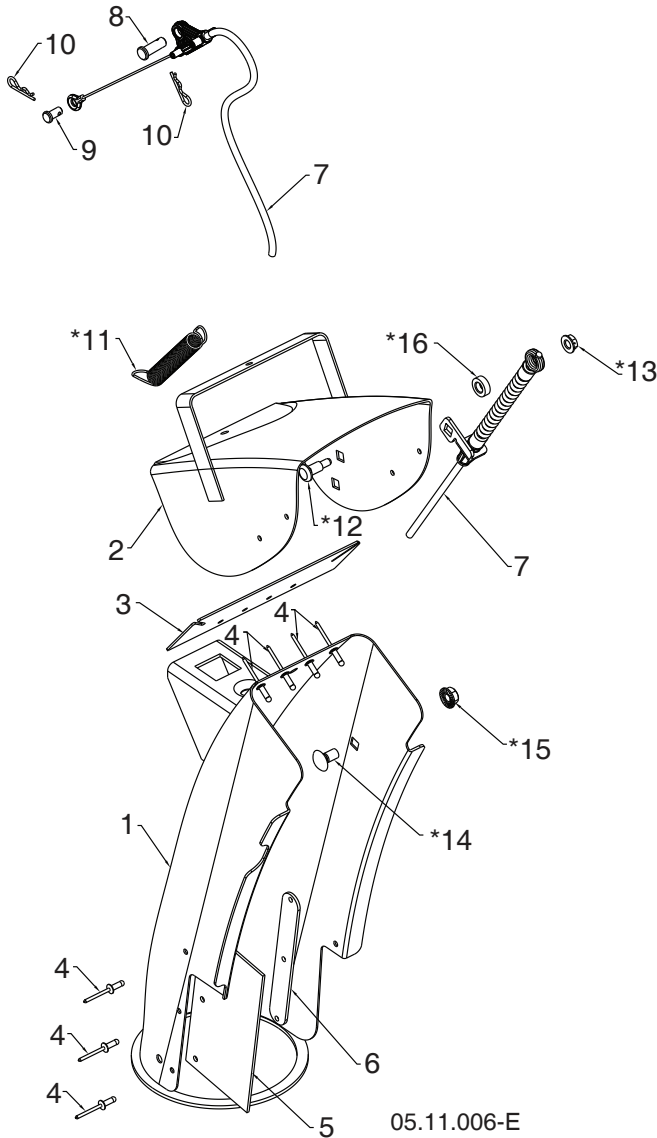

KEY NO.	PART NO.	DESCRIPTION
1	588077801	CHUTE WELDMENT (INCLUDES 1-6)
2	-----	DEFLECTOR WELDMENT
3	-----	DEFLECTOR SEAL
4	-----	POP RIVET
5	-----	CHUTE SNOW SHIELD
6	-----	SHIELD STRAP RETAINER
7	586961501	CABLE ASM DEFLECTOR - BOWDEN
8	581329401	PIN CLEVIS 5/16 X .875
9	585808301	PIN CLEVIS 1/4 X .312
10	423303	HAIRPIN RETAINER
*11	532184505	DEFLECTOR SPRING
*12	501417301	CARRIAGE BOLT 1/4-20 X .544
*13	585691401	NUT 1/4-20
*14	585832001	CARRIAGE BOLT 3/8-16 X .625
*15	873970500	NUT 5/16-18
*16	501417401	WASHER .362 X .625 X .205 NYLON

NOTE: ALL ITEMS MARKED WITH AN * ARE PROVIDED IN THE BAG OF ITEMS SHIPPED LOOSE WITH PRODUCT.

NOTE: All component dimensions given in U.S. inches. 1 inch = 25.4 mm
IMPORTANT: Use only Original Equipment Manufacturer (O.E.M.) replacement parts. Failure to do so could be hazardous, damage your snow thrower and void your warranty.

REPAIR PARTS HANDLES

SNOW THROWER - - MODEL NUMBER 944.525431

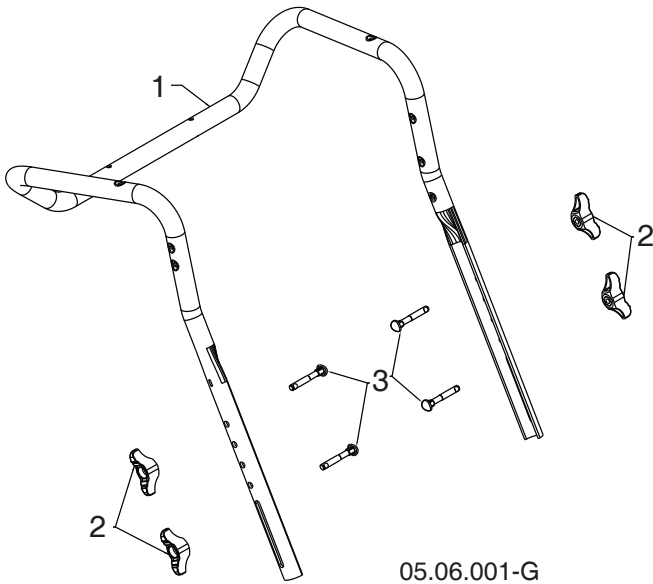

05.06.001-G

KEY NO.	PART NO.	DESCRIPTION
1	588160802	UPPER HANDLE
2	191938	HANDLE KNOB STD BLACK
3	588059901	SCREW 5/16-18 X 2.25 CONCAVE HEAD WITH PATCH

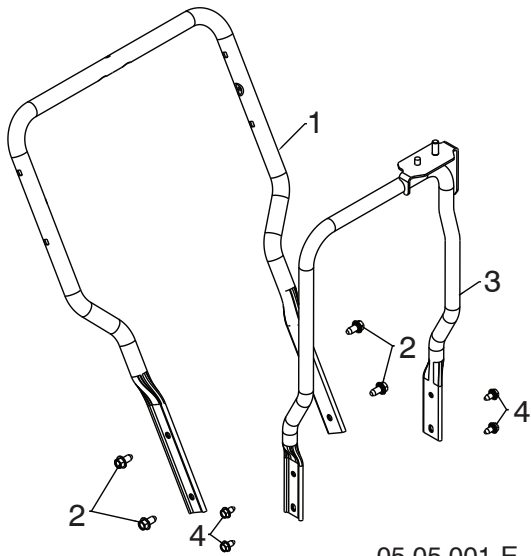

05.05.001-E

KEY NO.	PART NO.	DESCRIPTION
1	588672102	LOWER HANDLE
2	17000612	SCREW HEX WASH HD 3/8-16 X .75
3	581622002	CHUTE ROTATOR SUPPORT ASM
4	17000510	BOLT HEX 5/16-18

NOTE: All component dimensions given in U.S. inches. 1 inch = 25.4 mm
IMPORTANT: Use only Original Equipment Manufacturer (O.E.M.) replacement parts.
 Failure to do so could be hazardous, damage your snow thrower and void your warranty.

**REPAIR PARTS
DRIVE**

SNOW THROWER - - MODEL NUMBER 944.525431

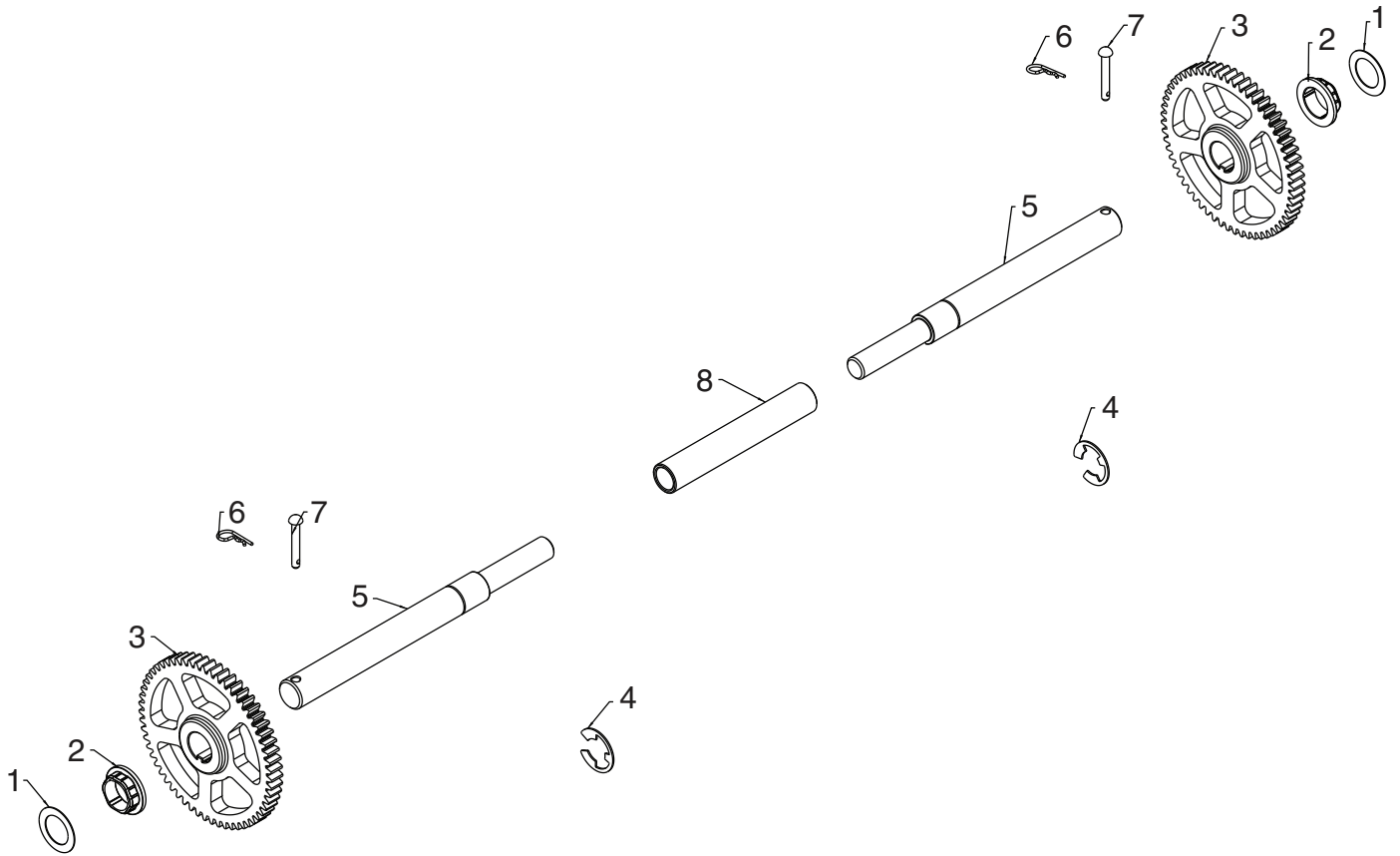

05.03.002-B

KEY NO.	PART NO.	DESCRIPTION
1	444949	WASHER 1.00
2	587978901	BUSHING HEX 1 SHAFT
3	588518601	GEAR 59T DRIVEN
4	12000053	RETAINING RING
5	580752601	AXLE SHAFT SPLIT
6	4497H	RETAINER SPRING 1 ZINC
7	126875X	RIVET RD HD DRILLED 1/4 DIA
8	580752501	AXLE SLEEVE

NOTE: All component dimensions given in U.S. inches. 1 inch = 25.4 mm
IMPORTANT: Use only Original Equipment Manufacturer (O.E.M.) replacement parts.
 Failure to do so could be hazardous, damage your snow thrower and void your warranty.

REPAIR PARTS
DRIVE

SNOW THROWER - - MODEL NUMBER 944.525431

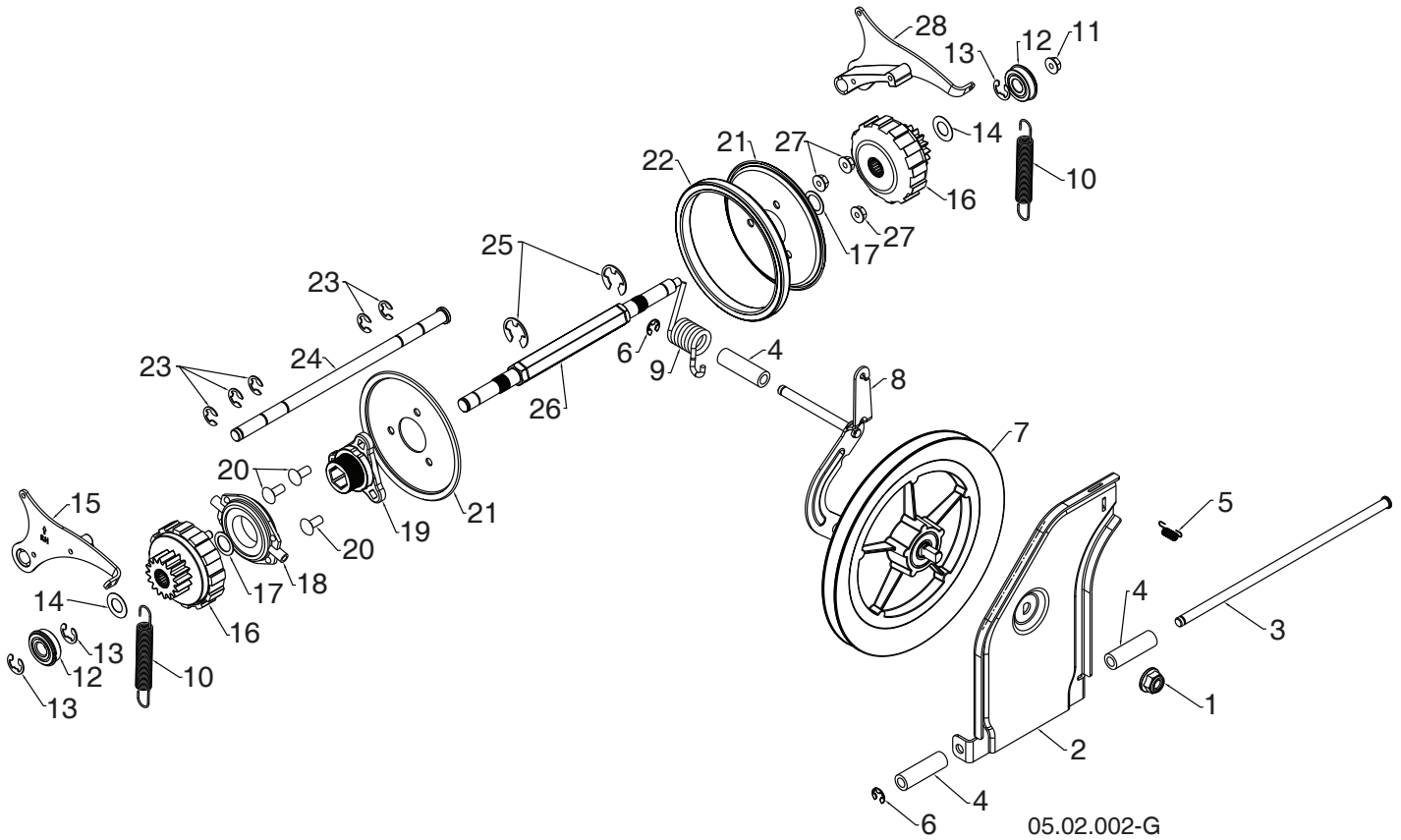

NOTE: All component dimensions given in U.S. inches. 1 inch = 25.4 mm
IMPORTANT: Use only Original Equipment Manufacturer (O.E.M.) replacement parts.
Failure to do so could be hazardous, damage your snow thrower and void your warranty.

**REPAIR PARTS
DRIVE**

SNOW THROWER - - MODEL NUMBER 944.525431

KEY NO.	PART NO.	DESCRIPTION
1	521991101	NUT HEX FLANGE LK 1/2-13
2	587703402	SWING PLATE FRICTION PULL
3	581123001	ROD TIP PLATE
4	581732701	SPACER DRIVE
5	193885	LATCH SPRING
6	12000007	E-RING RETAINER
7	581328401	FRICTION DISC COMBO PULLEY
8	587193403	BRACKET YOKE ASSEMBLY
9	581315301	SPRING TORSION DRIVE
10	585263801	EXTENSION SPRING
11	585691501	NUT HEX FLANGE LOCK 5/16-18
12	580756201	BEARING 9/16 I.D. 1622-2RSNR
13	580756102	RETAINING RING 1622-2RSNR
14	580751301	WASHER FLAT .59 I.D. X 1.065 X 25 GA
15	580756601	PAWL ASM RH
16	580756001	GEAR ASM PLANETARY
17	580756301	WASHER FLAT .6875 I.D. X 1.00 X 21 GA
18	175344	TRUNNION BEARING ASM
19	581090901	HUB RUBBER WHEEL
20	72110506	BOLT CARRIAGE 5/16-18 X .75
21	581091002	PLATE RUBBER WHEEL
22	581091101	RING RUBBER WHEEL
23	586644301	E-RING
24	580755101	ROD PAWL
25	12000022	E-RING
26	580752401	SHAFT REDUCTION PWR STR
27	751153	NUT HEX FLANGE LK 5/16-18
28	580756701	PAWL ASM LH

NOTE: All component dimensions given in U.S. inches. 1 inch = 25.4 mm
IMPORTANT: Use only Original Equipment Manufacturer (O.E.M.) replacement parts.
 Failure to do so could be hazardous, damage your snow thrower and void your warranty.

REPAIR PARTS

SNOW THROWER - - MODEL NUMBER 944.525431

CHASSIS / ENGINE / PULLEYS

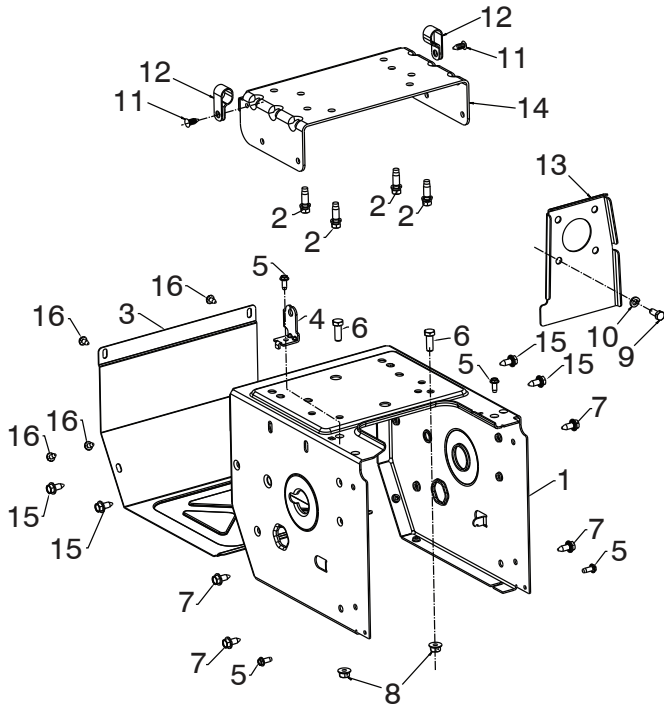
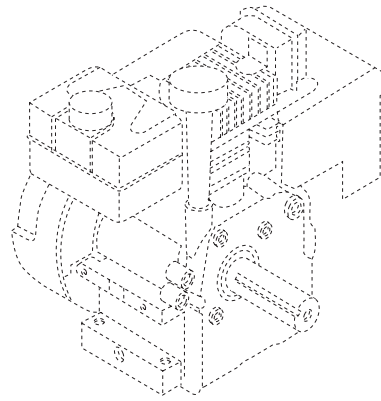

05.01.004-F

KEY NO.	PART NO.	DESCRIPTION
--	-----	B&S ENGINE 20M307-0001-F1
1	580839409	FRAME
2	150406	ENGINE BOLT 3/8-16 X 1.280 DOGPOINT
3	580839509	FRAME COVER
4	501060403	SHIFTER BRACKET
5	17060410	SCREW HEX WASHER 1/4-20 X 5/8
6	74760616	HEX HD BOLT - 3/8-16 X 1.00
7	428867	BOLT HEXHD WASHER 5/16-18 X .75
8	73900600	NUT LOCK 3/8-16
9	74610512	SCREW 5/16-24 X .750
10	10040500	WASHER LOCK
11	428124	PUSH FASTENER - .25 X .783
12	197991	P-CLIP
13	587125502	PLATE ENGINE FRONT B&S 250/305
14	587069903	BRACKET ENGINE MOUNTING B&S 205/305
15	585217501	BOLT HEXHD WASHER 5/16-18 X 1.00
16	17060408	SCREW HEX WASHER 1/4-20 X .500

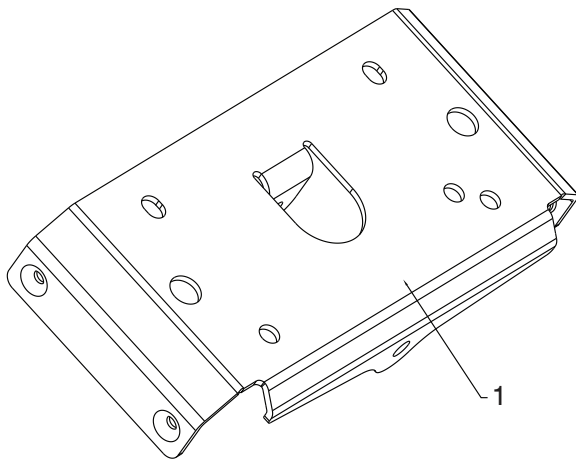

05.01.002-A

KEY NO.	PART NO.	DESCRIPTION
1	583940502	SMALL MOUNTING PLATE

NOTE: All component dimensions given in U.S. inches. 1 inch = 25.4 mm
IMPORTANT: Use only Original Equipment Manufacturer (O.E.M.) replacement parts.
 Failure to do so could be hazardous, damage your snow thrower and void your warranty.

REPAIR PARTS

SNOW THROWER - - MODEL NUMBER 944.525431

CHASSIS / ENGINE / PULLEYS

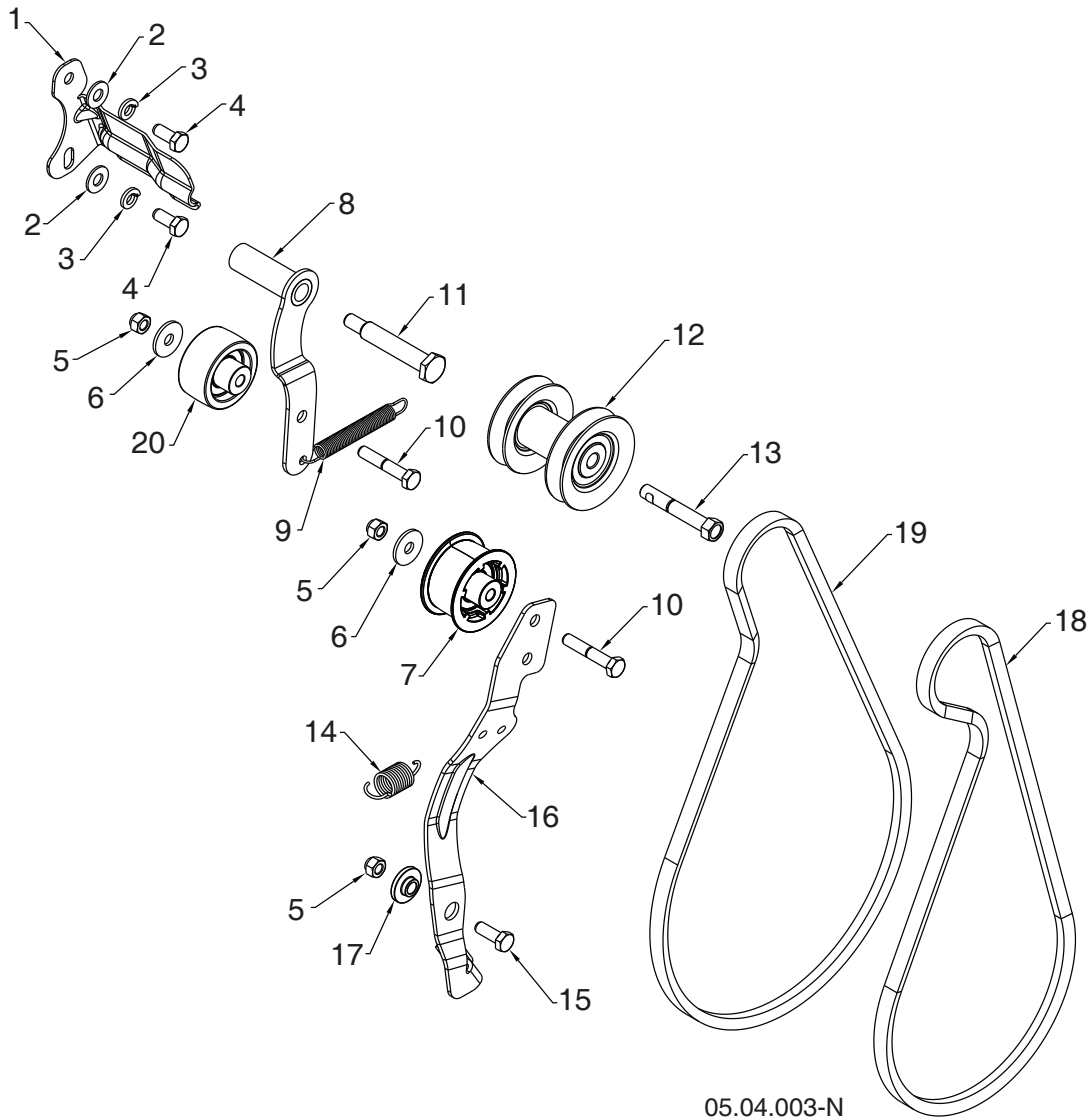

KEY NO.	PART NO.	DESCRIPTION	KEY NO.	PART NO.	DESCRIPTION
1	588492802	BELT KEEPER BRACKET	11	581413801	SHOULDER BOLT 5/16-24 X 2.15
2	19111216	WASHER 11/32 X 3/4 X 16 GA	12	587893703	PULLEY ASM ENGINE
3	10040500	LOCKWASHER 5/16 SPLIT HVY	13	582388401	BOLT HEXHD 3/8-24 X 2.375
4	74610512	CAPSCREW HEXHD 5/16-24 X .75 GR 5	14	587031201	RETURN SPRING IDLER ARM
5	73800500	NUT NYLOCK 5/16-18	15	74760514	BOLT HEXHD 5/16-18 X .875
6	59289	WASHER FLAT .328 X 1.00 X .097	16	580831106	IDLER ARM
7	581141401	IDLER PULLEY 2.0 W/SPACER	17	587343701	IDLER BUSHING PIVOT
8	581338203	IDLER ARM WELDMENT DRIVE	18	501818202	AUGER BELT HI CRANK
9	580753001	RETURN SPRING IDLER ARM DRIVE	19	585829902	DRIVE BELT HI CRANK
10	74760528	BOLT HEXHD 5/16-18 X 1.75	20	586880201	PULLEY IDLER 2.0 FLANGELESS W/SPACE

NOTE: All component dimensions given in U.S. inches. 1 inch = 25.4 mm
IMPORTANT: Use only Original Equipment Manufacturer (O.E.M.) replacement parts.
 Failure to do so could be hazardous, damage your snow thrower and void your warranty.

REPAIR PARTS

SNOW THROWER - - MODEL NUMBER 944.525431

CHASSIS / ENGINE / PULLEYS

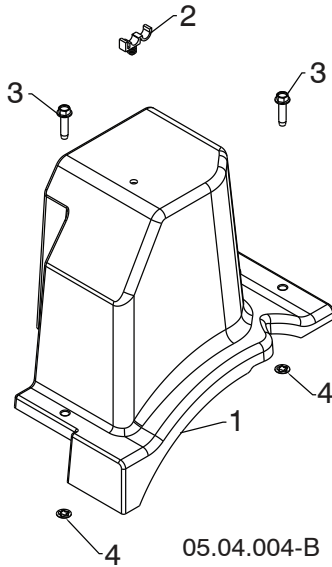

KEY NO.	PART NO.	DESCRIPTION
1	587105501	BELT COVER BLACK ASSEMBLY (INCLUDES 2 & 4)
2	-----	BOLT HEX WSH THDRL 1/4-20 X 1
3	145006	CABLE GUIDE
4	-----	PALNUT 1/4 IN

NOTE: All component dimensions given in U.S. inches. 1 inch = 25.4 mm
IMPORTANT: Use only Original Equipment Manufacturer (O.E.M.) replacement parts. Failure to do so could be hazardous, damage your snow thrower and void your warranty.

REPAIR PARTS
WHEELS

SNOW THROWER - - MODEL NUMBER 944.525431

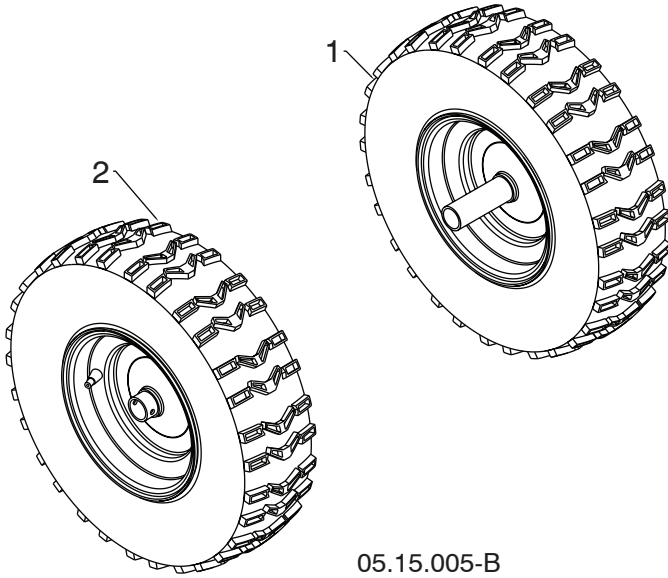

KEY NO.	PART NO.	DESCRIPTION
1	432335X613	WHEEL 16 X 4.80 NPS LH 1.00
2	432336X613	WHEEL 16 X 4.80 NPS RH 1.00

05.15.005-B

NOTE: All component dimensions given in U.S. inches. 1 inch = 25.4 mm
IMPORTANT: Use only Original Equipment Manufacturer (O.E.M.) replacement parts.
Failure to do so could be hazardous, damage your snow thrower and void your warranty.

REPAIR PARTS
BAG OF PARTS

SNOW THROWER - - MODEL NUMBER 944.525431

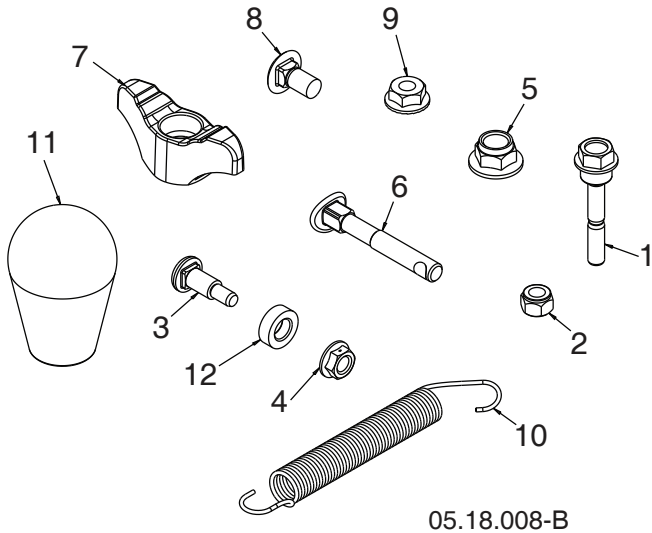

KEY NO.	PART NO.	DESCRIPTION
1	588077501	BOLT 1/4-20 X 1.81
2	73800400	NUT NYLOCK 1/4-20
3	501417301	BOLT SHOULDER
4	585691401	NUT HEX FL 1/4-20 CTR
5	588252901	NUT NYLOCK 3/8-16
6	588059901	BOLT 5/16-18 X 2.25 CONCAVE
7	189713X428	KNOB 5/16-18 X .625
8	585832001	BOLT 5/16-18 X .625
9	73970500	NUT SERR FL LOCK 5/16-18
10	184505	SPRING DEFLECT CHUTE
11	581697501	KNOB SOFT TOUCH SLOTTED
12	501417401	WASHER NYLON
NI	580947705	BAG PLASTIC 6.5 X 10.5
		WARNING
NI	588077606	KIT REPLACEMETN BAG OF PARTS

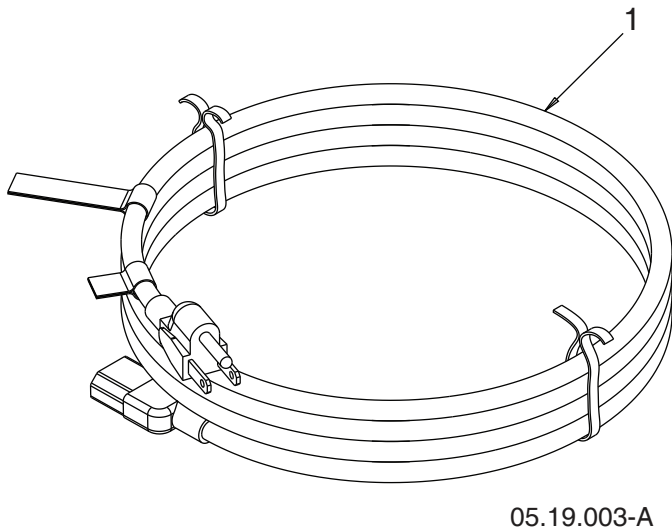

KEY NO.	PART NO.	DESCRIPTION
1	198563	CORD ELECTRIC 6219 10FT 125V 3WIRE



KEY NO.	PART NO.	DESCRIPTION
1	193071	SAFETY IGNITION KEY

NOTE: All component dimensions given in U.S. inches. 1 inch = 25.4 mm
IMPORTANT: Use only Original Equipment Manufacturer (O.E.M.) replacement parts.
 Failure to do so could be hazardous, damage your snow thrower and void your warranty.

**REPAIR PARTS
DECALS**

SNOW THROWER - - MODEL NUMBER 944.525431



1



3



2



4

KEY NO.	PART NO.	DESCRIPTION
1	184045	DECAL AUGER
2	199682	DECAL CHUTE
3	199683	DECAL AUGER SAFETY
4	184028	DECAL BELT GUIDE

05.16.001-A

NOTE: All component dimensions given in U.S. inches. 1 inch = 25.4 mm
IMPORTANT: Use only Original Equipment Manufacturer (O.E.M.) replacement parts.
 Failure to do so could be hazardous, damage your snow thrower and void your warranty.

**REPAIR PARTS
DECALS**

SNOW THROWER - - MODEL NUMBER 944.525431

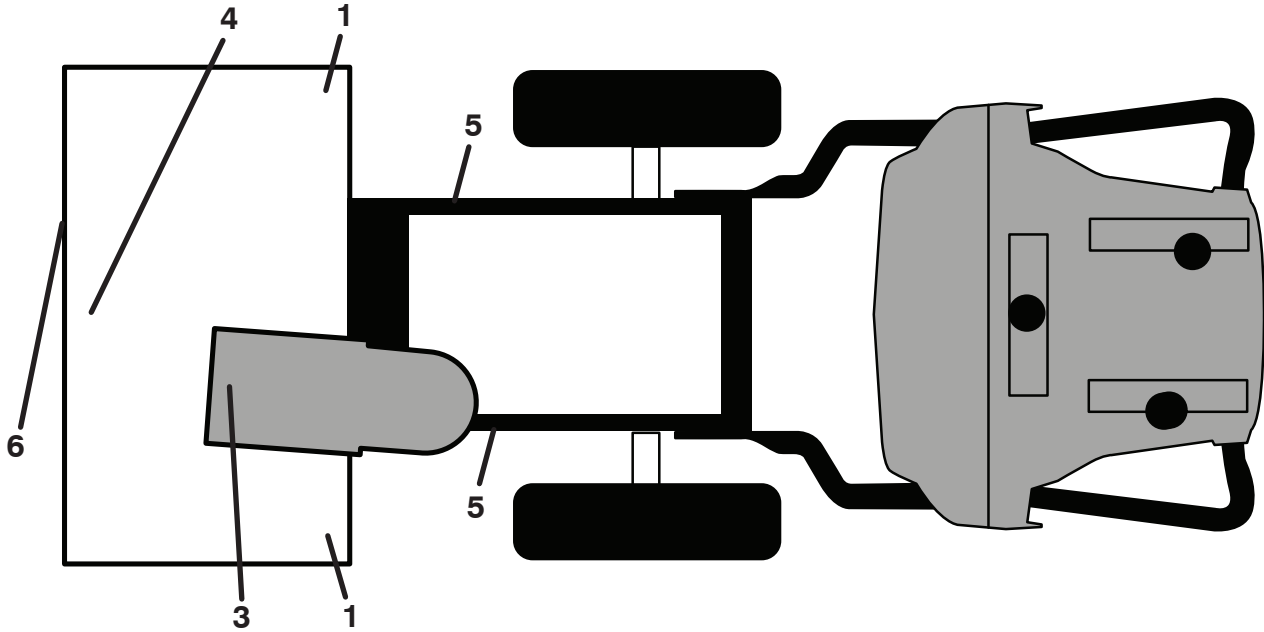

KEY NO.	PART NO.	DESCRIPTION
1	199683	DECAL, DANGER
3	199682	DECAL, DANGER, DEFLECTOR
4	184045	DECAL, DANGER
5	184028	DECAL, BELT GUARD
6	501077201	DECAL, AUGER HOUSING BRANDED
--	582344101	OWNER'S MANUAL, ENGLISH
--	582344201	OWNER'S MANUAL, FRENCH

NOTE: All component dimensions given in U.S. inches. 1 inch = 25.4 mm
IMPORTANT: Use only Original Equipment Manufacturer (O.E.M.) replacement parts.
 Failure to do so could be hazardous, damage your snow thrower and void your warranty.

REPAIR PARTS ENGINE, B&S

SNOW THROWER - - MODEL NUMBER 944.525431 MODEL NUMBER 20M307-0001-F1

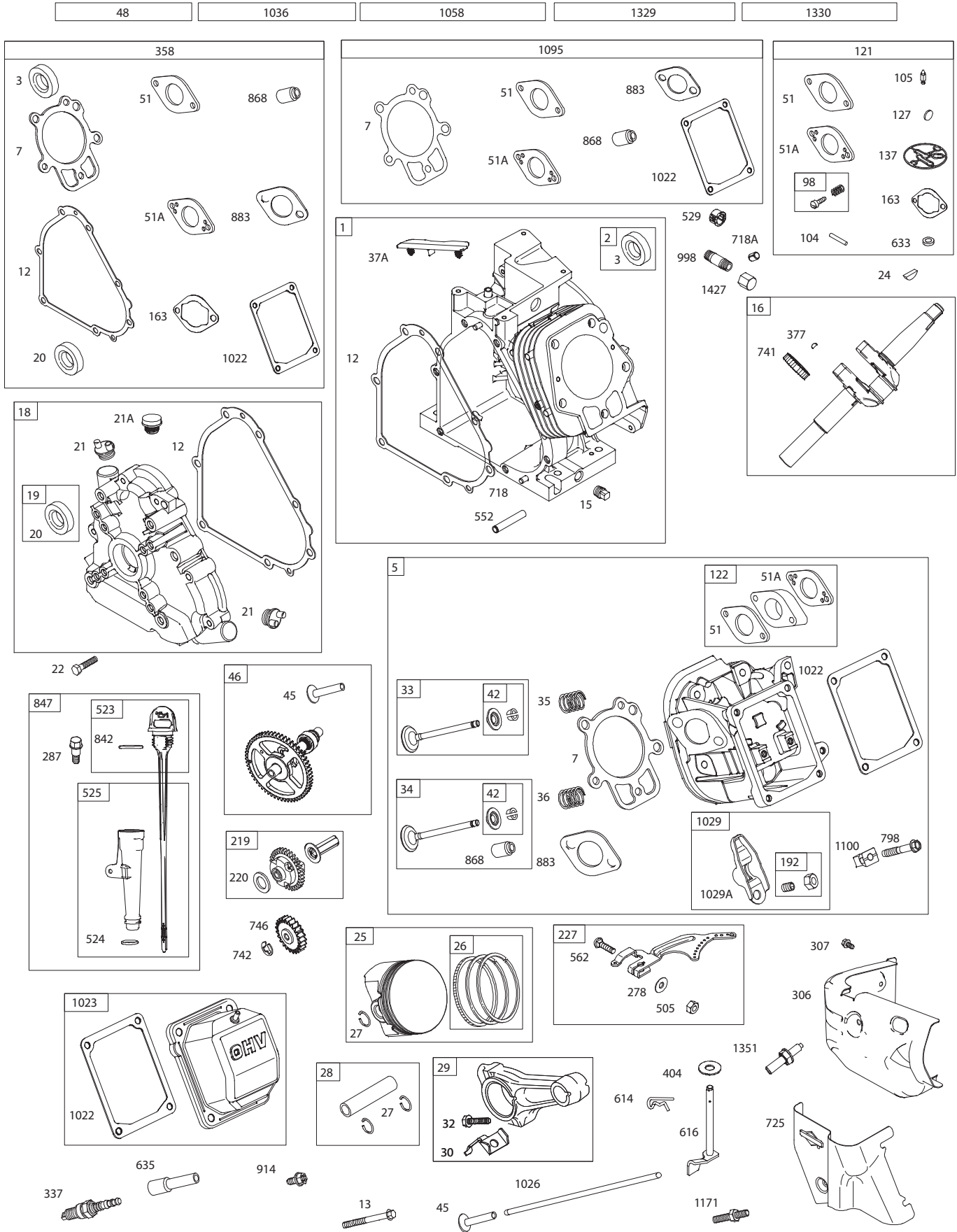

REPAIR PARTS ENGINE, B&S

SNOW THROWER - - MODEL NUMBER 944.525431 MODEL NUMBER 20M307-0001-F1

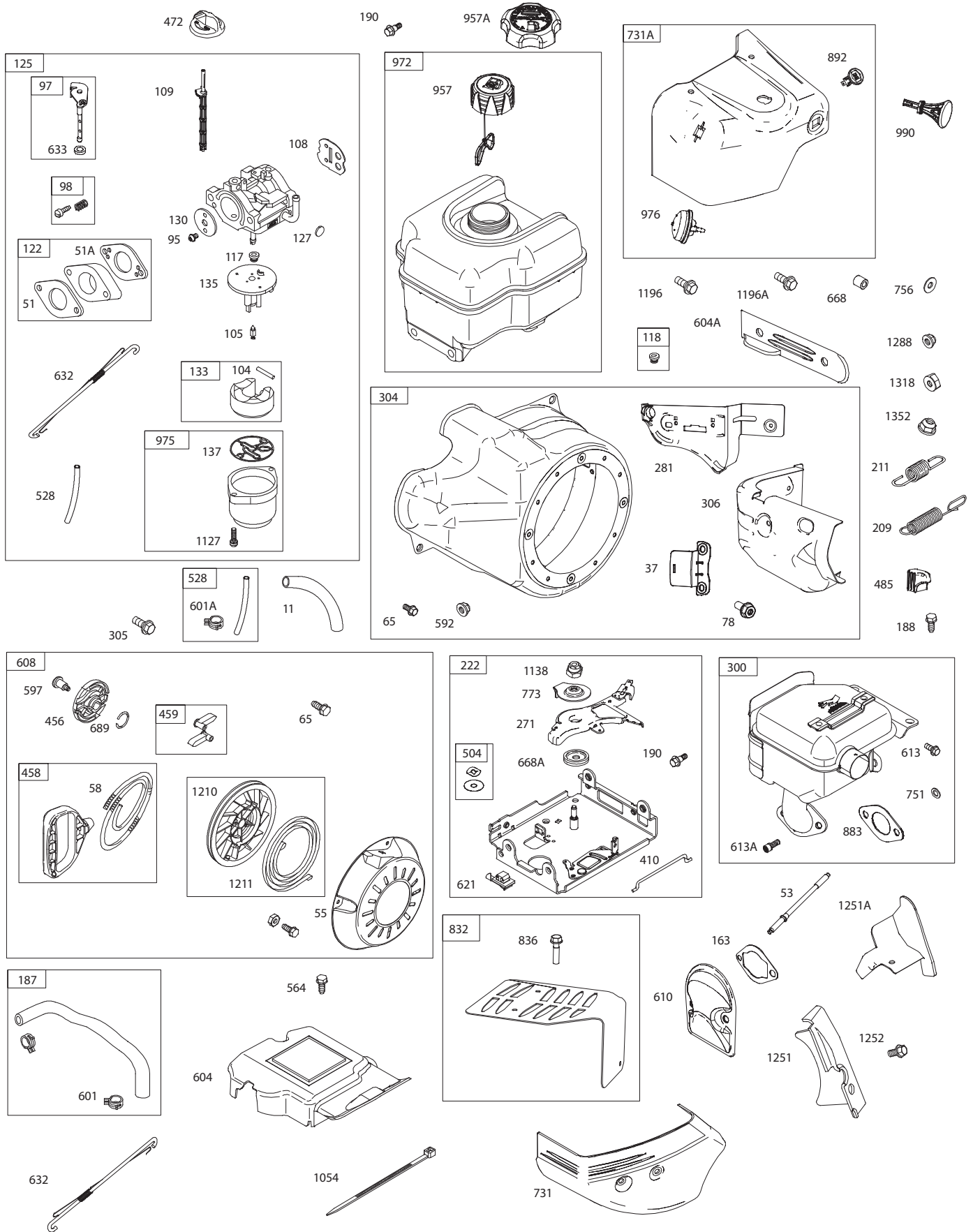

REPAIR PARTS ENGINE, B&S

SNOW THROWER - - MODEL NUMBER 944.525431 MODEL NUMBER 20M307-0001-F1

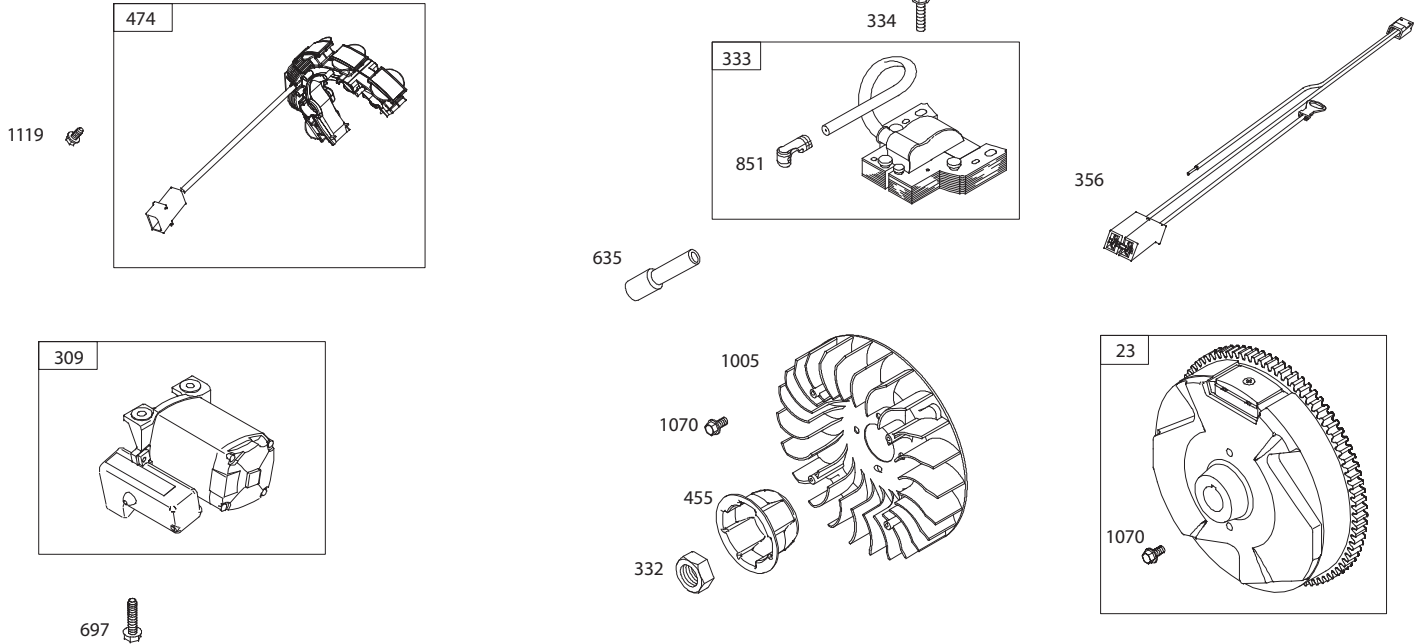

KEY NO.	PART NO.	DESCRIPTION	KEY NO.	PART NO.	DESCRIPTION
1	794849	CYLINDER ASSEMBLY	32	690976	SCREW (CONNECTING ROD)
2	698340	KIT-BUSHING/SEAL (MAGNETO SIDE)	33	499596	VALVE-EXHAUST
3	391086S	SEAL-OIL (MAGNETO SIDE)	34	795199	VALVE-INTAKE
5	799860	HEAD-CYLINDER	35	694865	SPRING-VALVE (INTAKE)
7	694872	GASKET-CYLINDER HEAD	36	694865	SPRING-VALVE (EXHAUST)
11	696750	TUBE-BREATHER	37	591544	GUARD-FLYWHEEL
12	694953	GASKET-CRANKCASE	37A	795715	GUARD-FLYWHEEL
13	794829	SCREW (CYLINDER HEAD)	42	499586	KEEPER-VALVE
15	691686	PLUG-OIL DRAIN	45	690977	TAPPET-VALVE
16	794720	CRANKSHAFT	46	795697	CAMSHAFT
18	791965	COVER-CRANKCASE	48	794910	SHORT BLOCK
19	698340	KIT-BUSHING/SEAL (PTO SIDE)	51	694874	GASKET-INTAKE
20	391086S	SEAL-OIL (PTO SIDE)	51A	694875	GASKET-INTAKE
21	281658S	CAP-OIL FILL	53	795017	STUD (CARBURETOR)
21A	799857	CAP-OIL FILL	55	696710	HOUSING-REWIND STARTER
22	794825	SCREW (CRANKCASE COVER/SUMP)	58	693389	ROPE-STARTER
23	794812	FLYWHEEL	65	697725	SCREW (REWIND STARTER)
24	222698S	KEY-FLYWHEEL (ALUMINUM)	78	795026	SCREW (FLYWHEEL GUARD)
25	792117	PISTON ASSEMBLY (STD)	95	690718	SCREW (THROTTLE VALVE)
--	792144	PISTON ASSEMBLY (.020" OVERSIZE)	97	696387	SHAFT-THROTTLE
26	792026	RING SET (STANDARD)	98	695408	KIT-IDLE SPEED
--	792073	RING SET (.020" OVERSIZE)	104	694918	PIN-FLOAT HINGE
27	690975	LOCK-PISTON PIN	105	696136	VALVE-FLOAT NEEDLE
28	696581	PIN-PISTON	108	696143	VALVE-CHOKE
29	694691	ROD-CONNECTING	109	793520	SHAFT-CHOKE
30	694692	DIPPER-CONNECTING ROD	117	796080	JET-MAIN (STANDARD)
			118	796128	JET-MAIN (HIGH ALTITUDE) (5000 > 9000 FEET)
			121	796137	KIT-CARBURETOR OVERHAUL

REPAIR PARTS**SNOW THROWER - - MODEL NUMBER 944.525431****ENGINE, B&S****MODEL NUMBER 20M307-0001-F1**

KEY NO.	PART NO.	DESCRIPTION	KEY NO.	PART NO.	DESCRIPTION
122	694876	SPACER-CARBURETOR	528	793006	HOSE-PRIMER
125	796122	CARBURETOR	529	791822	GROMMET
127	690727	PLUG-WELCH	552	694674	BUSHING-GOVERNOR CRANK
130	696139	VALVE-THROTTLE	562	798197	BOLT (GOVERNOR CONTROL LEVER)
133	694914	FLOAT-CARBURETOR			
135	698780	TUBE-FUEL TRANSFER	564	699854	SCREW (CONTROL COVER)
137	698781	GASKET-FLOAT BOWL	592	690800	NUT (REWIND STARTER)
163	692277	GASKET-AIR CLEANER	597	691696	SCREW (PAWL FRICTION PLATE)
187	791879	LINE-FUEL (FORMED)			
188	699479	SCREW (CONTROL BRACKET)	601	791850	CLAMP-HOSE (GREEN)
190	699220	SCREW (FUEL TANK)	601A	691638	CLAMP-HOSE (PRIMER HOSE)
192	690083	ADJUSTER-ROCKER ARM	604	696758	COVER-CONTROL
209	694867	SPRING-GOVERNOR (RED)	604A	790473	COVER-CONTROL
211	695307	SPRING-GOVERNED IDLE (NO COLOR/PLAIN)	608	699335	STARTER-REWIND
			610	794541	ARRESTER-INTAKE
219	693578	GEAR-GOVERNOR	613	794846	SCREW (MUFFLER) (M6X.71MM)
220	691724	WASHER (GOVERNOR GEAR)			
222	794800	BRACKET-CONTROL	613A	794844	SCREW (MUFFLER) (M8X.85MM)
227	694864	LEVER-GOVERNOR CONTROL			
271	797554	LEVER-CONTROL	614	691620	PIN-COTTER
278	798196	WASHER (GOVERNOR CONTROL LEVER)	616	795758	CRANK-GOVERNOR
			621	692310	SWITCH-STOP
281	697268	PANEL-CONTROL	632	796324	SPRING/LINK-MECHANICAL GOVERNOR
287	699234	SCREW (DIPSTICK TUBE)			
300	794948	MUFFLER	633	690998	SEAL-CHOKE/THROTTLE SHAFT (THROTTLE SHAFT)
304	795699	HOUSING-BLOWER			
305	699481	SCREW (BLOWER HOUSING)	635	691909	BOOT-SPARK PLUG
306	697240	SHIELD-CYLINDER	663	699854	SCREW (CONTROL PANEL)
307	794822	SCREW (CYLINDER SHIELD)	668	794539	SPACER (SNOW HOOD)
309	591036	MOTOR-STARTER	668A	694257	SPACER (CONTROL BRACKET)
332	794824	NUT (FLYWHEEL)	689	691855	SPRING-FRICTION
333	591459	ARMATURE-MAGNETO	697	795012	SCREW (STARTER MOTOR)
334	699477	SCREW (MAGNETO ARMATURE)	718	690959	PIN-LOCATING (CYLINDER)
			718A	695178	PIN-LOCATING (CYLINDER HEAD)
337	491055S	PLUG-SPARK			
356	793206	WIRE-STOP	725	696756	SHIELD-HEAT
358	795201	GASKET SET-ENGINE	731	794540	HOOD-SNOW
377	690979	KEY-WOODRUFF	731A	793621	HOOD-SNOW
404	795759	WASHER (GOVERNOR CRANK)	735	795901	CORD-STARTER
			741	691288	GEAR-TIMING
410	695382	LINK-CONTROL	742	692564	RETAINER-E RING
455	794867	CUP-FLYWHEEL	746	694679	GEAR-IDLER
456	692299	PLATE-PAWL FRICTION	751	794839	WASHER (STOP WIRE)
458	699334	KIT-HANDLE/ROPE	756	794839	WASHER (SNOW HOOD)
459	281505S	PAWL-RATCHET	773	694258	RETAINER (CONTROL BRACKET)
472	791948	KNOB-CHOKE SHAFT			
474	797090	ALTERNATOR	798	697890	SCREW (ROCKER COVER)
485	695755	KNOB-CONTROL	832	797095	GUARD-MUFFLER
504	695383	WASHER SET-FRICTION	836	699234	SCREW (MUFFLER GUARD)
505	793515	NUT (GOVERNOR CONTROL LEVER)	842	795015	SEAL-O RING (DIPSTICK)
			847	795087	DIPSTICK/TUBE ASSEMBLY
523	790477	DIPSTICK	851	692424	TERMINAL-SPARK PLUG
524	691876	SEAL-O RING (DIPSTICK TUBE)	868	794086	SEAL-VALVE
525	792041	TUBE-DIPSTICK	883	695398	GASKET-EXHAUST

REPAIR PARTS

SNOW THROWER - - MODEL NUMBER 944.525431

ENGINE, B&S

MODEL NUMBER 20M307-0001-F1

KEY NO.	PART NO.	DESCRIPTION	KEY NO.	PART NO.	DESCRIPTION
892	791944	SWITCH-KEY	1138	694255	NUT (CONTROL BRACKET) (HIGH SPEED CONTROL)
914	794827	SCREW (ROCKER COVER)	1171	794828	STUD (ROCKER ARM COVER)
957	799719	CAP-FUEL (SERVICE CAP)	1196	696692	SCREW (SNOW HOOD)
957A	792647	CAP-FUEL (ORIGINAL CAP)	1196A	798785	SCREW (SNOW HOOD) (#10-24X.65)
972	799863	TANK-FUEL	1210	498144	PULLEY/SPRING ASSEMBLY (PULLEY)
975	698783	BOWL-FLOAT	1211	498144	PULLEY/SPRING ASSEMBLY (SPRING)
976	793382	PRIMER-CARBURETOR	1251	696762	SHIELD-SNOW
990	794696	KEY SET	1251A	790471	SHIELD-SNOW
998	792928	PIPE-OIL	1252	699481	SCREW (SNOW SHIELD)
1005	794815	FAN-FLYWHEEL	1288	794838	NUT (SNOW HOOD)
1022	690971	GASKET-ROCKER COVER	1318	698111	KNOB-SNOW HOOD
1023	698042	COVER-ROCKER	1329	21M314-	
1026	592673	ROD-PUSH (INTAKE AND EXHAUST)	1351	794847	REPLACEMENT ENGINE STUD (CYLINDER SHIELD)
1029	690972	ARM-ROCKER	1352	795016	NUT (SPARK PLUG SHIELD) (SERRATED)
1029A	807323	ARM-ROCKER	1427	695757	CAP-PIPE
1036		LABEL-EMISSIONS (AVAILABLE FROM A BRIGGS & STRATTON AUTHORIZED DEALER)			
1054	280275	TIE-CABLE			
1058	277104	OPERATOR'S MANUAL			
1070	794821	SCREW (FLYWHEEL FAN)			
1095	795200	GASKET SET-VALVE	CARBURETOR OVERHAUL KIT		KEY NO. 121
1100	791959	PIVOT-ROCKER ARM	ENGINE GASKET SET		KEY NO. 358
1119	699772	SCREW (ALTERNATOR)	VALVE GASKET SET		KEY NO. 1095
1127	695407	SCREW (FLOAT BOWL)			

Engine Power Rating Information

The gross power rating for individual gas engine models is labeled in accordance with SAE (Society of Automotive Engineers) code J1940 (Small Engine Power & Torque Rating Procedure), and rating performance has been obtained and corrected in accordance with SAE J1995 (Revision 2002-05). Torque values are derived at 3060 RPM; horsepower values are derived at 3600 RPM. Actual gross engine power will be lower and is affected by, among other things, ambient operating conditions and engine-to-engine variability. Given both the wide array of products on which engines are placed and the variety of environmental issues applicable to operating the equipment, the gas engine will not develop the rated gross power when used in a given piece of power equipment (actual "on-site" or net power). This difference is due to a variety of factors including, but not limited to, accessories (air cleaner, exhaust, charging, cooling, carburetor, fuel pump, etc.), application limitations, ambient operating conditions (temperature, humidity, altitude), and engine-to-engine variability. Due to manufacturing and capacity limitations, Briggs & Stratton may substitute an engine of higher rated power for this Series engine.

Get it fixed, at your home or ours!

Just Call:

1-800-4-MY-HOME[®]

(1-800-469-4663)

24 hours a day, 7 days a week

For the repair of major brand appliances **in your own home...**
no matter who made it, no matter who sold it!

For your nearest **Sears Parts and Service** location,
to bring in products like vacuums, lawn equipment and electronics.

For **Sears Parts & Service**, to order the replacement parts,
accessories and owner's manuals that you need to do-it-yourself.

www.sears.ca

To purchase or inquire about a Sears Maintenance Agreement, call:

1-800-361-6665

9 a.m. – 11 p.m. Mon. – Fri., EST, 9 a.m. – 4 p.m. Sat.

Pour service en français:

1-800-LE-FOYER^{MC}

(1-800-533-6937)

www.sears.ca



® / TM Trademarks of Sears Brands Management Corporation used under license by Sears Canada

^{MD} Marque déposée / ^{MC} Marque de commerce de Sears Brands Management Corporation utilisée en vertu d'une licence de Sears Canada