

SEARS

**OWNER'S
MANUAL**

**MODEL NO.
944.629672**

**Important:
Read and follow
all Safety Rules
and Instructions
Before Operating
This Equipment**

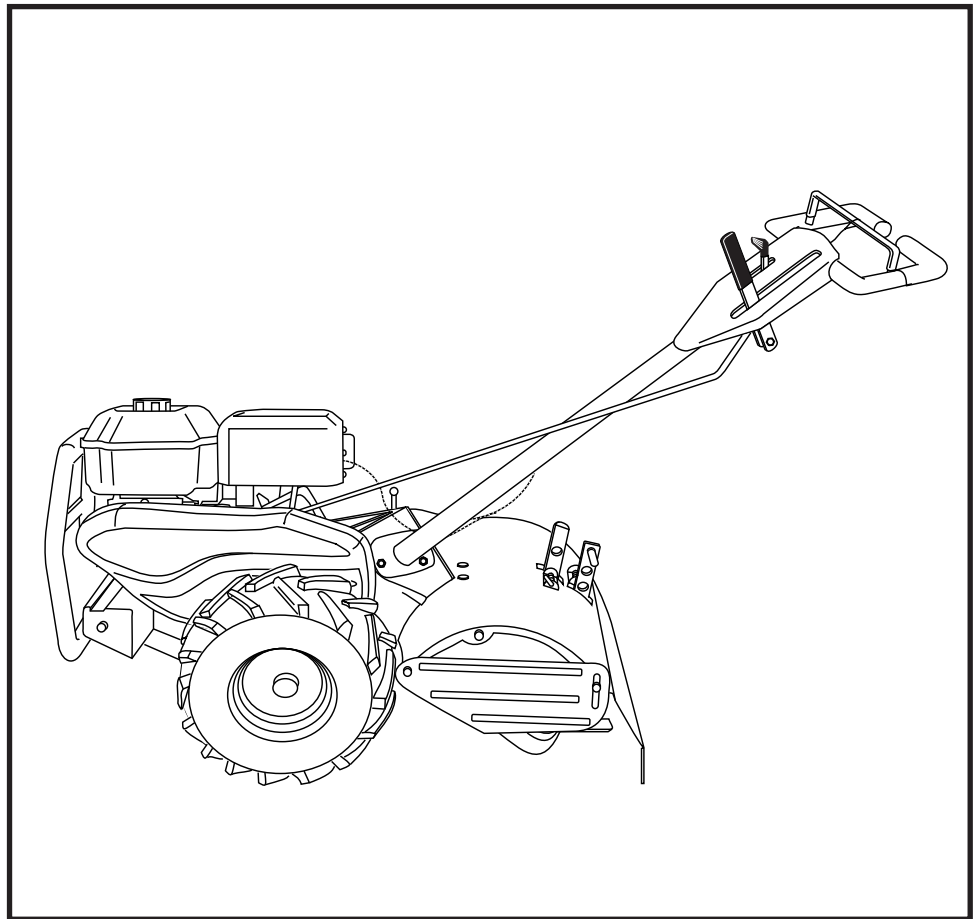

CRAFTSMAN®

**900 SERIES
17 INCH TINE WIDTH
REAR TINE TILLER WITH
DUAL ROTATING TINES**

- **Assembly**
- **Operation**
- **Maintenance**
- **Service and Adjustments**
- **Repair Parts**

Sears Canada, Inc., Toronto, Ontario M5B 2B8

434934

SAFETY RULES



SAFE OPERATION PRACTICES FOR WALK-BEHIND POWERED ROTARY TILLERS



TRAINING

- Read the Owner's Manual carefully. Be thoroughly familiar with the controls and the proper use of the equipment. Know how to stop the unit and disengage the controls quickly.
- Never allow children to operate the equipment. Never allow adults to operate the equipment without proper instruction.
- Keep the area of operation clear of all persons, particularly small children, and pets.

PREPARATION

- Thoroughly inspect the area where the equipment is to be used and remove all foreign objects.
- Disengage all clutches and shift into neutral before starting the engine (motor).
- Do not operate the equipment without wearing adequate outer garments. Wear footwear that will improve footing on slippery surfaces.
- Handle fuel with care; it is highly flammable.
- Use an approved fuel container.
- Never add fuel to a running engine or hot engine.
- Fill fuel tank outdoors with extreme care. Never fill fuel tank indoors.
- Replace gasoline cap securely and clean up spilled fuel before restarting.
- Use extension cords and receptacles as specified by the manufacturer for all units with electric drive motors or electric starting motors.
- Never attempt to make any adjustments while the engine (motor) is running (except where specifically recommended by manufacturer).

OPERATION

- Do not put hands or feet near or under rotating parts.
- Exercise extreme caution when operating on or crossing gravel drives, walks, or roads. Stay alert for hidden hazards or traffic. Do not carry passengers.
- After striking a foreign object, stop the engine (motor), remove the wire from the spark plug, thoroughly inspect the tiller for any damage, and repair the damage before restarting and operating the tiller.
- Exercise caution to avoid slipping or falling.
- If the unit should start to vibrate abnormally, stop the engine (motor) and check immediately for the cause. Vibration is generally a warning of trouble.
- Stop the engine (motor) when leaving the operating position.
- Take all possible precautions when leaving the machine unattended. Disengage the tines, shift into neutral, and stop the engine.
- Before cleaning, repairing, or inspecting, shut off the engine and make certain all moving parts have stopped. Disconnect the spark plug wire, and keep the wire away from the plug to prevent accidental starting. Disconnect the cord on electric motors.

- Do not run the engine indoors; exhaust fumes are dangerous.
- Never operate the tiller without proper guards, plates, or other safety protective devices in place.
- Keep children and pets away.
- Do not overload the machine capacity by attempting to till too deep at too fast a rate.
- Never operate the machine at high speeds on slippery surfaces. Look behind and use care when backing.
- Never allow bystanders near the unit.
- Use only attachments and accessories approved by the manufacturer of the tiller.
- Never operate the tiller without good visibility or light.
- Be careful when tilling in hard ground. The tines may catch in the ground and propel the tiller forward. If this occurs, let go of the handlebars and do not restrain the machine.

MAINTENANCE AND STORAGE

- Keep machine, attachments, and accessories in safe working condition.
- Check shear pins, engine mounting bolts, and other bolts at frequent intervals for proper tightness to be sure the equipment is in safe working condition.
- Never store the machine with fuel in the fuel tank inside a building where ignition sources are present, such as hot water and space heaters, clothes dryers, and the like. Allow the engine to cool before storing in any enclosure.
- Always refer to the operator's guide instructions for important details if the tiller is to be stored for an extended period.

- IMPORTANT -

CAUTIONS, IMPORTANTS, AND NOTES ARE A MEANS OF ATTRACTING ATTENTION TO IMPORTANT OR CRITICAL INFORMATION IN THIS MANUAL.

IMPORTANT: USED TO ALERT YOU THAT THERE IS A POSSIBILITY OF DAMAGING THIS EQUIPMENT.

NOTE: Gives essential information that will aid you to better understand, incorporate, or execute a particular set of instructions.



Look for this symbol to point out important safety precautions. It means CAUTION!!! BECOME ALERT!!! YOUR SAFETY IS INVOLVED.



CAUTION: Always disconnect spark plug wire and place wire where it cannot contact spark plug in order to prevent accidental starting when setting up, transporting, adjusting or making repairs.

PRODUCT SPECIFICATIONS

Gasoline Capacity: Unleaded Regular	3 Quarts (2.8L)
Oil (API-SG-SL): (Capacity: 19 oz./0,6L)	SAE 30 (Above 40°F/4°C) SAE 3w-30 (Below 40°F/4°C)
Spark Plug :	Champion RC12YC (GAP: .030"/0.76mm)

CONGRATULATIONS on your purchase of a new tiller. It has been designed, engineered and manufactured to give you the best possible dependability and performance.

Should you experience any problems you cannot easily remedy, please contact your nearest authorized service center/department. They have competent, well-trained technicians and the proper tools to service or repair this unit.

Please read and retain this manual. The instructions will enable you to assemble and maintain your tiller properly. Always observe the "SAFETY RULES".

CUSTOMER RESPONSIBILITIES

- Read and observe the safety rules.
- Follow a regular schedule in maintaining, caring for and using your tiller.
- Follow the instructions under the "Maintenance" and "Storage" sections of this Owner's Manual.

IMPORTANT: THIS UNIT IS EQUIPPED WITH AN INTERNAL COMBUSTION ENGINE AND SHOULD NOT BE USED ON OR NEAR ANY UNIMPROVED FOREST-COVERED, BRUSH-COVERED OR GRASS COVERED LAND UNLESS THE ENGINE'S EXHAUST SYSTEM IS EQUIPPED WITH A SPARK ARRESTER MEETING APPLICABLE LOCAL OR STATE LAWS (IF ANY). IF A SPARK ARRESTER IS USED, IT SHOULD BE MAINTAINED IN EFFECTIVE WORKING ORDER BY THE OPERATOR.

IN THE STATE OF CALIFORNIA THE ABOVE IS REQUIRED BY LAW (SECTION 4442 OF THE CALIFORNIA PUBLIC RESOURCES CODE). OTHER STATES MAY HAVE SIMILAR LAWS. FEDERAL LAWS APPLY ON FEDERAL LANDS. SEE YOUR SEARS AUTHORIZED SERVICE CENTER/DEPARTMENT FOR SPARK ARRESTER. REFER TO THE REPAIR PARTS SECTION OF THIS MANUAL FOR PART NUMBER.

TABLE OF CONTENTS

SAFETY RULES	2	SERVICE & ADJUSTMENTS	15-18
CUSTOMER RESPONSIBILITIES	3	STORAGE	19
PRODUCT SPECIFICATIONS	3	TROUBLESHOOTING	20
ASSEMBLY	4-6	REPAIR PARTS-TILLER	21-27
OPERATION	7-11	REPAIR PARTS-ENGINE	28-32
MAINTENANCE SCHEDULE	12	WARRANTY	35
MAINTENANCE	12-14	PARTS ORDER/SERVICE	BACK COVER

ASSEMBLY

Your new tiller has been assembled at the factory with exception of those parts left unassembled for shipping purposes. To ensure safe and proper operation of your tiller all parts and hardware you assemble must be tightened securely. Use the correct tools as necessary to insure proper tightness.

TOOLS REQUIRED FOR ASSEMBLY

A socket wrench set will make assembly easier. Standard wrench sizes are listed.

- (1) Utility knife
- (1) Wire cutter
- (1) Screwdriver
- (1) Tire pressure gauge
- (1) Pair of pliers
- (1) 9/16" wrench

OPERATOR'S POSITION (See Fig. 1)

When right or left hand is mentioned in this manual, it means when you are in the operating position (standing behind tiller handles).

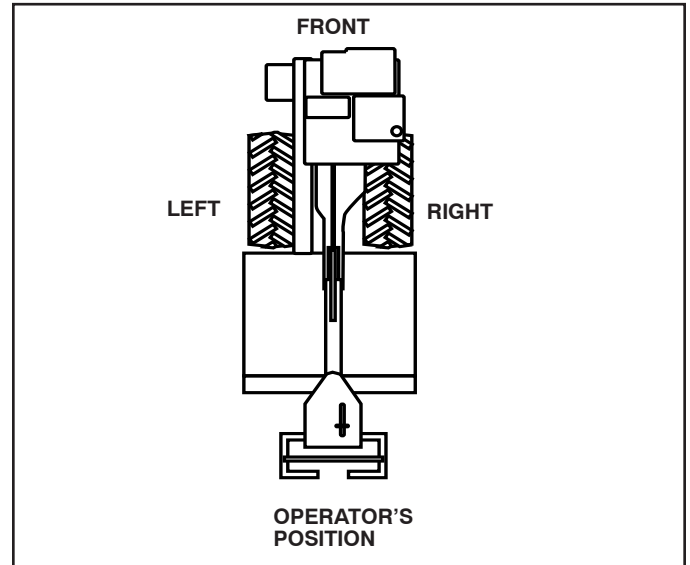
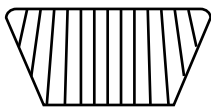
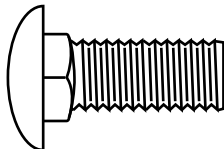

Fig. 1

CONTENTS OF HARDWARE PACK



(2) Handle Lock



(1) Carriage Bolt
3/8-16 UNC x 1 Gr. 5

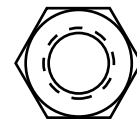

(1) Center Locknut
3/8-16 UNC

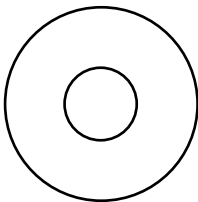

(1) Flat Washer 13/32 x 1 x 11 Ga.

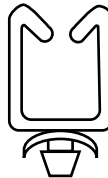

(1) Cable Clip

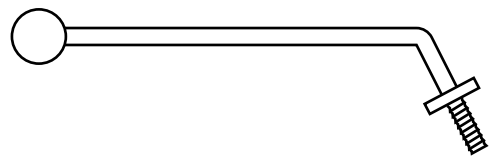

(1) Handle Lock Lever

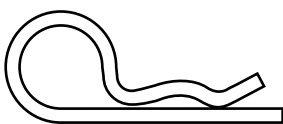

(1) Hairpin Clip

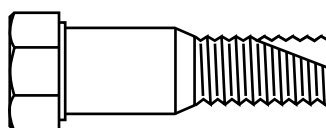

(1) Pivot Bolt
3/8-16 UNC Grade 5

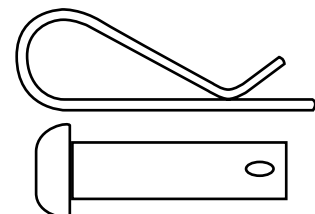

(2) Shear Pins & Clips

ASSEMBLY

UNPACKING CARTON (See Fig. 2)



CAUTION: Be careful of exposed staples when handling or disposing of cartoning material.

IMPORTANT: WHEN UNPACKING AND ASSEMBLING TILLER, BE CAREFUL NOT TO STRETCH OR KINK CABLES.

- While holding handle assembly, cut cable ties securing handle assembly to top frame. Let handle assembly rest on tiller.
- Remove top frame of carton.
- Slowly ease handle assembly up and place on top of carton.
- Cut down right hand front and right hand rear corners of carton. Lay side carton wall down.
- Remove packing material from handle assembly.
- Separate shift rod from handle assembly.

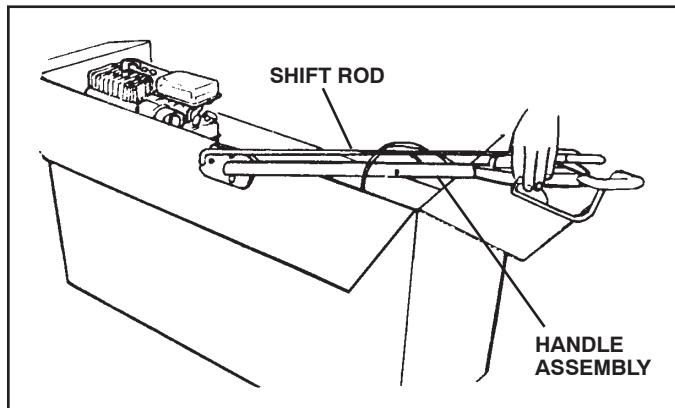

Fig. 2

INSTALL HANDLE (See Figs. 3, 4, and 5)

- Insert one handle lock (with teeth facing outward) in gearcase notch. (Apply grease on smooth side of handle lock to aid in keeping lock in place until handle assembly is lowered into position.)

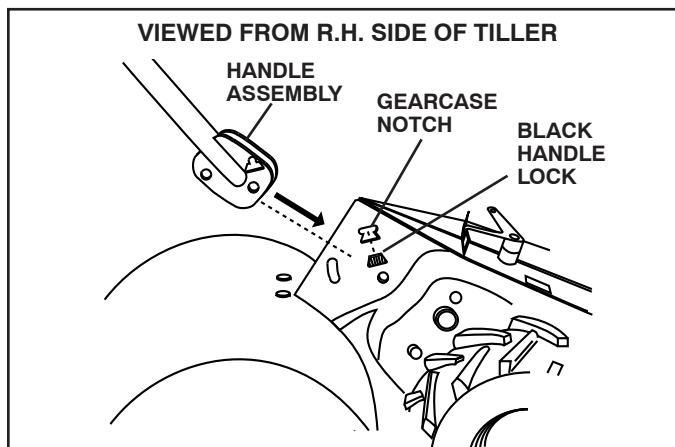

Fig. 3

- Grasp handle assembly. Hold in "up" position. Be sure handle lock remains in gearcase notch. Slide handle assembly into position.

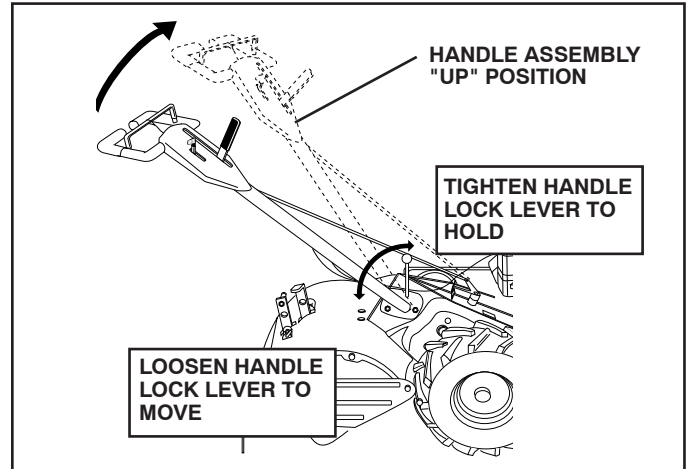

Fig. 4

- Rotate handle assembly down. Insert rear carriage bolt first, with head of bolt on L.H. side of tiller and loosely assemble locknut (See Fig. 5).
- Insert pivot bolt in front part of plate and tighten.
- Cut down remaining corners of carton and lay panels flat.
- Lower the handle assembly. Tighten nut on carriage bolt so handle moves with some resistance. This will allow for easier adjustment.
- Place flat washer on threaded end of handle lock lever.
- Insert handle lock lever through handle base and gearcase. Screw in handle lock lever just enough to hold lever in place.
- Insert second handle lock (with teeth inward) in the slot of the handle base (just inside of washer).
- Raise handle assembly to highest position and securely tighten handle lock lever by rotating clockwise. Leaving handle assembly in highest position will make it easier to connect shift rod.

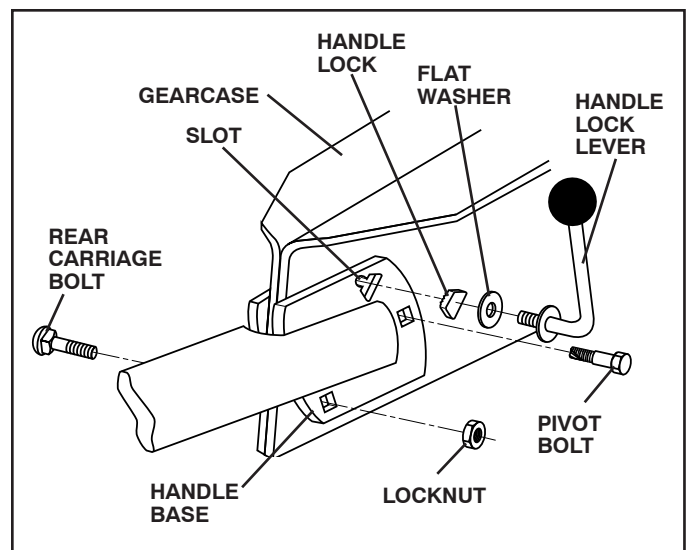

Fig. 5

ASSEMBLY

INSERT CABLE CLIP (See Fig. 6)

- Insert plastic cable clip into hole on the back of handle column. Push cables into clip.

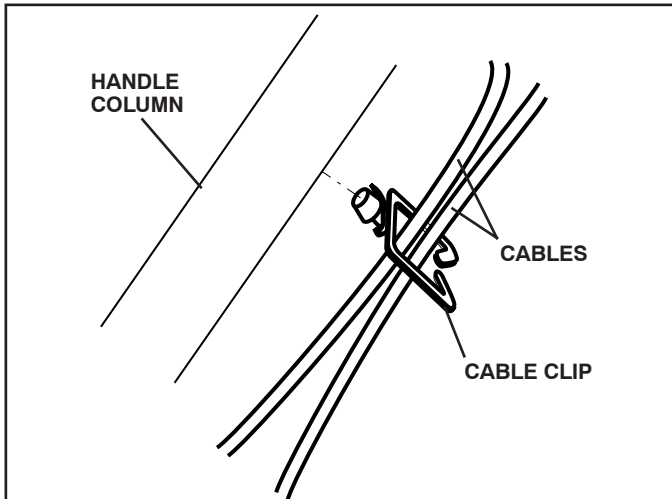

Fig. 6

CONNECT SHIFT ROD (See Fig. 7)

- Insert end of shift rod farthest from bend into hole of shift lever indicator.
- Insert hairpin clip through hole of shift rod to secure with bend of clip on right side.

REMOVE TILLER FROM CRATE

- adjust handle assembly to lowest position. Be sure lock lever is tightened securely.
- Make sure shift lever indicator is in "N" (neutral) position (See Fig. 7)
- Tilt tiller forward by lifting handle. Separate cardboard cover from leveling shield.
- Rotate tiller handle to the right and pull tiller out of carton.

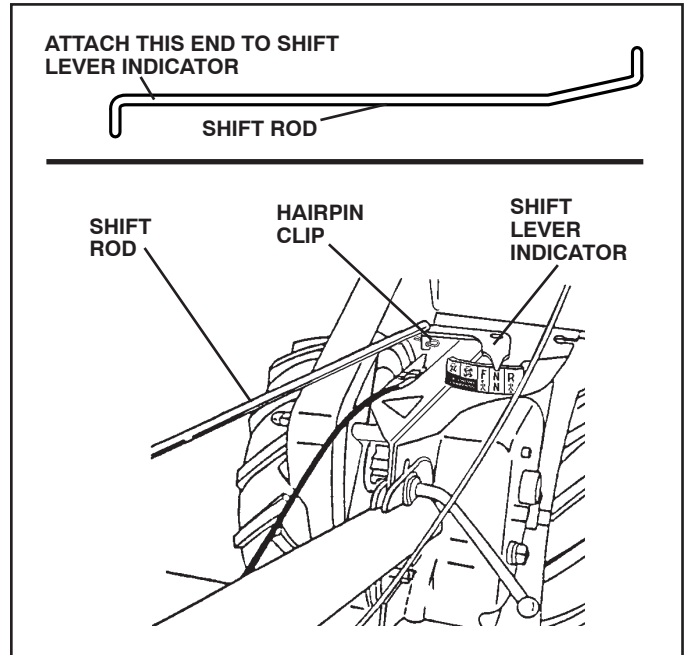

Fig. 7

CHECK TIRE PRESSURE

The tires on your unit were overinflated at the factory for shipping purposes. Correct and equal tire pressure is important for best tilling performance.

- Reduce tire pressure to 20 PSI.

HANDLE HEIGHT

- Handle height may be adjusted to better suit operator. (See "TO ADJUST HANDLE HEIGHT" in the Service and Adjustments section of this manual).

OPERATION

KNOW YOUR TILLER

READ THIS OWNER'S MANUAL AND SAFETY RULES BEFORE OPERATING YOUR TILLER.

Compare the illustrations with your tiller to familiarize yourself with the location of various controls and adjustments. Save this manual for future reference.

These symbols may appear on your Tiller or in literature supplied with the product. Learn and understand their meaning.

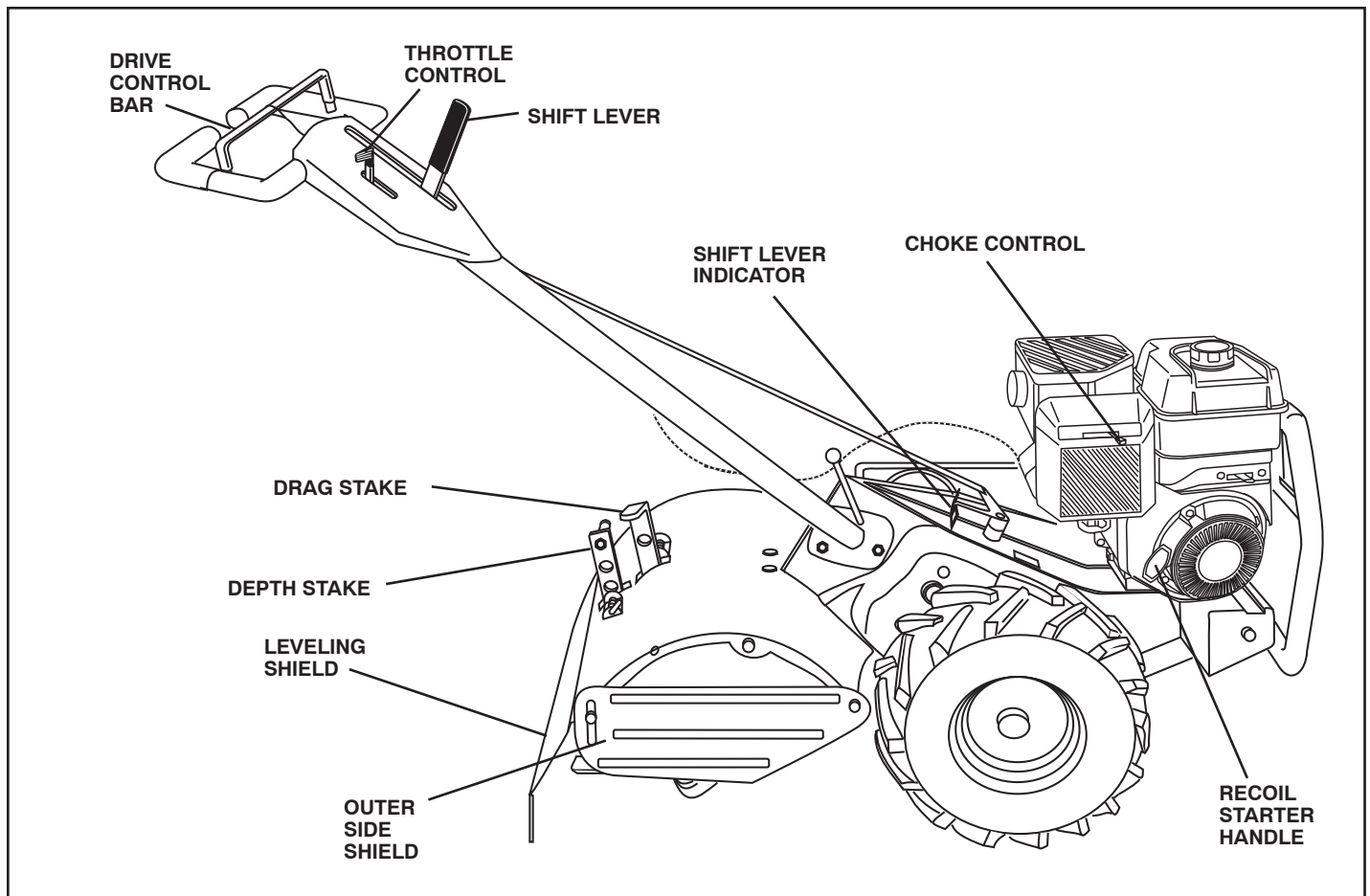
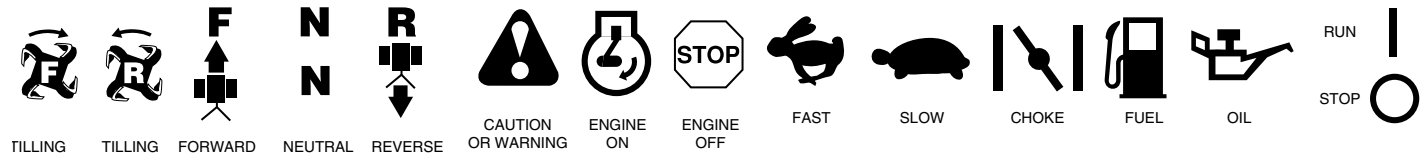

Fig. 8

MEETS ANSI SAFETY REQUIREMENTS

Our tillers conform to the safety standards of the American National Standards Institute.

DRIVE CONTROL BAR - Used to engage tines.

DEPTH STAKE - Controls depth at which tiller will dig.

DRAG STAKE - Controls forward speed in forward rotating till position.

OUTER SIDE SHIELD - Adjustable to protect small plants from being buried.

LEVELING SHIELD - Levels tilled soil.

THROTTLE CONTROL - Used to control engine speed.

SHIFT LEVER - Used to shift transmission gears.

SHIFT LEVER INDICATOR - Shows which gear the transmission is in.

RECOIL STARTER HANDLE - Used to start the engine.

CHOKE CONTROL - Used when starting a cold engine.

OPERATION



The operation of any tiller can result in foreign objects thrown into the eyes, which can result in severe eye damage. Always wear safety glasses or eye shields before starting your tiller and while tilling. We recommend a wide vision safety mask over spectacles or standard safety glasses.

HOW TO USE YOUR TILLER

Know how to operate all controls before adding fuel and oil or attempting to start engine.

STOPPING (See Fig. 9)

TINES AND DRIVE

- Release drive control bar to stop movement.
- Move shift lever to “N” (neutral) position.

ENGINE

- Move throttle control to “STOP” position. If equipped with stop switch, move switch to “STOP” position.
- Never use choke to stop engine.

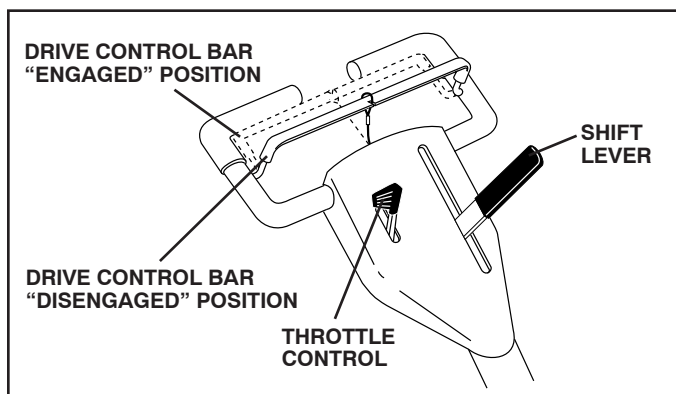

Fig. 9

TINE OPERATION - WITH WHEEL DRIVE (See Fig. 9)

- Always release drive control bar before moving shift lever into another position.
- Tine movement is achieved by moving shift lever to either the counter rotating (Ⓔ) till position or the forward rotating (Ⓕ) till position and engaging drive control bar.

FORWARD - WHEELS ONLY/TINES STOPPED

- Release drive control bar and move shift lever indicator to “F” (forward) position. Engage drive control bar and tiller will move forward.

REVERSE - WHEELS ONLY/TINES STOPPED

- DO NOT STAND DIRECTLY BEHIND TILLER.
- Release the drive control bar.
- Move throttle control to “SLOW” position.
- Move shift lever indicator to “R” (reverse) position.
- Hold drive control bar against the handle to start tiller movement.

HARD TO SHIFT GEARS

- Briefly engage drive control bar and release or rock tiller forward and backward until are able to shift gears.

DEPTH STAKE (See Fig. 10)

The depth stake can be raised or lowered to allow you more versatile tilling and cultivating, or to more easily transport your tiller.

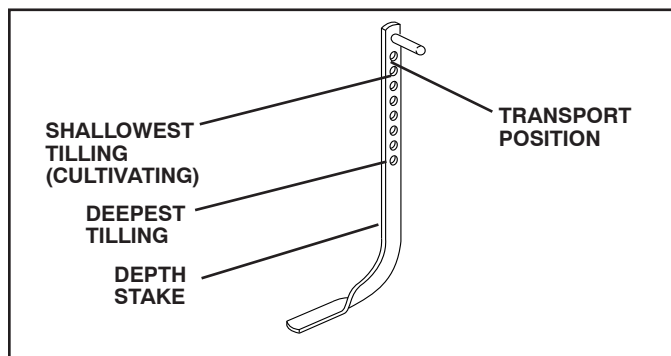

Fig. 10

DRAG STAKE (See Fig. 11)

The drag stake should be raised when tilling the counter rotating (Ⓔ) till position. The drag stake should be lowered when tilling in the forward rotating (Ⓕ) till position.

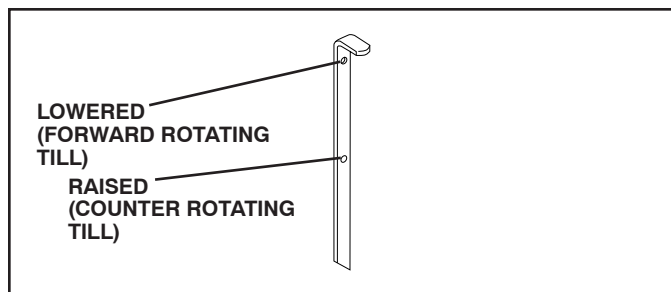

Fig. 11

TILLING (See Fig. 12)

- Release depth stake pin. Pull the depth stake up for increased tilling depth. Place depth stake pin in hole of depth stake to lock in position.
- Place shift lever indicator in (Ⓔ) till position.
- Hold the drive control bar against the handle to start tilling movement. Tines and wheels will both turn.
- Move throttle control to “FAST” position for deep tilling. To cultivate, throttle control can be set at any desired speed, depending on how fast or slow you wish to cultivate.

IMPORTANT: ALWAYS RELEASE DRIVE CONTROL BAR BEFORE MOVING SHIFT LEVER INTO ANOTHER POSITION.

OPERATION

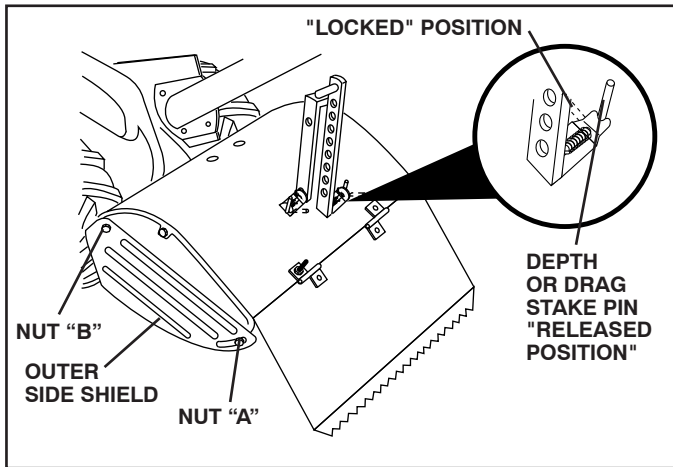

Fig. 12

TURNING

- Release the clutch control bar.
- Move throttle control to "SLOW" position.
- Place shift lever indicator in "F" (forward) position. Tines will not turn.
- Lift handle to raise tines out of ground.
- Swing the handle in the opposite direction you wish to turn, being careful to keep feet and legs away from tines.
- When you have completed your turn-around, release the clutch control bar and lower handle. Place shift lever in till position and move throttle control to desired speed. To begin tilling, hold clutch control bar against the handle.

CULTIVATING

- Use the forward rotating tine drive when cultivating, tilling soft ground or tilling pre-tilled soil.
- Release depth and drag stake pins. Lower drag stake. Pull the depth stake up for increased tilling depth. Place proper pin in hole of depth stake or drag stake to lock in position.
- Place shift lever indicator in counter rotating (R) till position.
- Hold the drive control bar against the handle to start tilling movement. Tines and wheels will both turn.
- Move throttle control "FAST" position for deep tilling. To cultivate, throttle control can be set at any desired speed, depending on how fast or slow you wish to cultivate.
- **Always lower the drag stake when using the forward rotating tine drive.**

OUTER SIDE SHIELDS (See Fig. 12)

The back edges of the outer side shields are slotted so that the shields can be raised for deep tilling and lowered for shallow tilling to protect small plants from being buried. Loosen nut "A" in slot and nut "B". Move shield to desired position (both sides). Retighten nuts.

TO TRANSPORT



CAUTION: Before lifting or transporting, allow tiller engine and muffler to cool. Disconnect spark plug wire. Drain gasoline from fuel tank.

AROUND THE YARD

- Release the depth stake pin. Move the depth stake down to the top hole for transporting the tiller. Place depth stake pin in hole of depth stake to lock in position. This prevents tines from scuffing the ground.
- Place shift lever indicator in "F" (forward) position for transporting.
- Hold the drive control bar against the handle to start tiller movement. Tines will not turn.
- Move throttle control to desired speed.

AROUND TOWN

- Disconnect spark plug wire.
- Drain fuel tank.
- Transport in upright position to prevent oil leakage.

BEFORE STARTING ENGINE

IMPORTANT: BE VERY CAREFUL NOT TO ALLOW DIRT TO ENTER THE ENGINE WHEN CHECKING OR ADDING OIL OR FUEL. USE CLEAN OIL AND FUEL AND STORE IN APPROVED, CLEAN, COVERED CONTAINERS. USE CLEAN FILL FUNNELS.

CHECK ENGINE OIL LEVEL (See Fig. 13)

- The engine in your unit has been shipped, from the factory, already filled with SAE 30 summer weight oil.
- With engine level, clean area around oil filler plug and remove plug.
- Engine oil should be to point of overflowing when engine is level. For approximate capacity see "PRODUCT SPECIFICATIONS" on page 3 of this manual. All oil must meet A.P.I. Service Classification SG-SL.
- Reinstall engine oil cap and tighten.
- For cold weather operation you should change oil for easier starting (See oil viscosity chart in the Maintenance section of this manual).
- To change engine oil, see the Maintenance section in this manual.

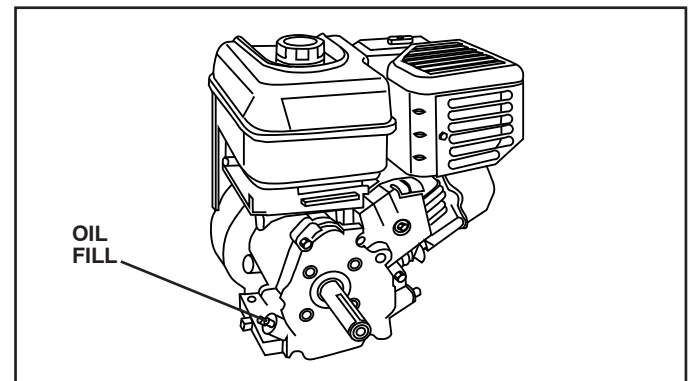

Fig. 13

OPERATION

ADD GASOLINE

- Fill fuel tank to bottom of filler neck. Do not overfill. Use fresh, clean, regular unleaded gasoline with a minimum of 87 octane. (Use of leaded gasoline will increase carbon and lead oxide deposits and reduce valve life). Do not mix oil with gasoline. Purchase fuel in quantities that can be used within 30 days to assure fuel freshness.



CAUTION: Fill to within 1/2 inch of top of fuel tank to prevent spills and to allow for fuel expansion. If gasoline is accidentally spilled, move machine away from area of spill. Avoid creating any source of ignition until gasoline vapors have disappeared.

Wipe off any spilled oil or fuel. Do not store, spill or use gasoline near an open flame.

IMPORTANT: WHEN OPERATING IN TEMPERATURES BELOW 32°F (0°C), USE FRESH, CLEAN WINTER GRADE GASOLINE TO HELP INSURE GOOD COLD WEATHER STARTING.

CAUTION: Alcohol blended fuels (called gasohol or using ethanol or methanol) can attract moisture which leads to separation and formation of acids during storage. Acidic gas can damage the fuel system of an engine while in storage. To avoid engine problems, the fuel system should be emptied before storage of 30 days or longer. Drain the gas tank, start the engine and let it run until the fuel lines and carburetor are empty. Use fresh fuel next season. See Storage Instructions for additional information. Never use engine or carburetor cleaner products in the fuel tank or permanent damage may occur.

TO START ENGINE (See Fig. 14)



CAUTION: Keep drive control bar in "DISENGAGED" position when starting engine.

When starting engine for the first time or if engine has run out of fuel, it will take extra pulls of the recoil starter to move fuel from the tank to the engine.

- Make sure spark plug wire is properly connected.
- Move shift lever indicator to "N" (neutral) position.
- Place throttle control in "FAST" position.
- Turn fuel shut-off valve 1/4 turn to open position.
- Move choke control to choke position.
- Grasp recoil starter handle with one hand and grasp tiller handle with other hand. Pull rope out slowly until engine reaches start of compression cycle (rope will pull slightly harder at this point).
- Pull recoil starter handle quickly. Do not let starter handle snap back against starter.

- If engine fires but does not start, move choke control to half choke position. Pull recoil starter handle until engine starts.
- When engine starts, slowly move choke control to "RUN" position as engine warms up.

NOTE: A warm engine requires less choking to start.

- Move throttle control to desired running position.
- Allow engine to warm up for a few minutes before engaging tines.

NOTE: If at a high altitude (3000 feet) or in cold temperatures (below 32°F), the carburetor fuel mixture may need to be adjusted for best engine performance. See "TO ADJUST CARBURETOR" in the Service and Adjustments section of this manual.

NOTE: If engine does not start, see troubleshooting points.

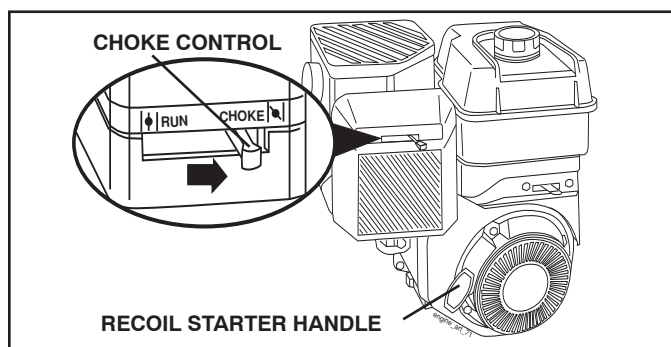

Fig. 14

TILLING HINTS



CAUTION: Until you are accustomed to handling your tiller, start actual field use with throttle in slow position (mid-way between "FAST" and "IDLE").

- Tilling is digging into, turning over, and breaking up packed soil before planting. Loose, unpacked soil helps root growth. Best tilling depth is 4" to 6" (10-15 cm). A tiller will also clear the soil of unwanted vegetation. The decomposition of this vegetable matter enriches the soil. Depending on the climate (rainfall and wind), it may be advisable to till the soil at the end of the growing season to further condition the soil.
- Soil conditions are important for proper tilling. Tines will not readily penetrate dry, hard soil which may contribute to excessive bounce and difficult handling of your tiller. Hard soil should be moistened before tilling; however, extremely wet soil will "ball-up" or clump during tilling. Wait until the soil is less wet in order to achieve the best results. When tilling in the fall, remove vines and long grass to prevent them from wrapping around the tine shaft and slowing your tilling operation.

OPERATION

- You will find tilling much easier if you leave a row untilled between passes. Then go back between tilled rows. (See Fig. 15) There are two reasons for doing this. First, wide turns are much easier to negotiate than about-faces. Second, the tiller won't be pulling itself, and you, toward the row next to it.
- Do not lean on handle. This takes weight off the wheels and reduces traction. To get through a really tough section of sod or hard ground, apply upward pressure on handle or lower the depth stake.

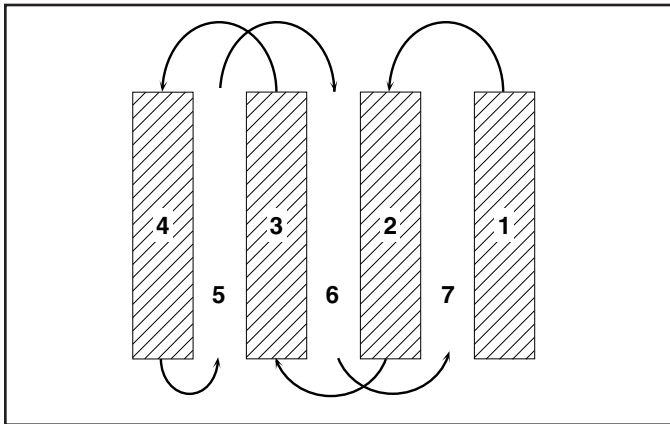

Fig. 15

CULTIVATING

Cultivating is destroying the weeds between rows to prevent them from robbing nourishment and moisture from the plants. At the same time, breaking up the upper layer of soil crust will help retain moisture in the soil. Best digging depth is 1" to 3" (2.5-7.5 cm). Lower the outer side shields to protect small plants from being buried.

- Cultivate up and down the rows at a speed which will allow tines to uproot weeds and leave the ground in rough condition, promoting no further growth of weeds and grass (See Fig. 16).
- Do not lean on handle, this takes weight off the wheels, reduces traction, and may cause the tiller to skip over the ground.
- **Always lower the drag stake when using the forward rotating tine drive.**

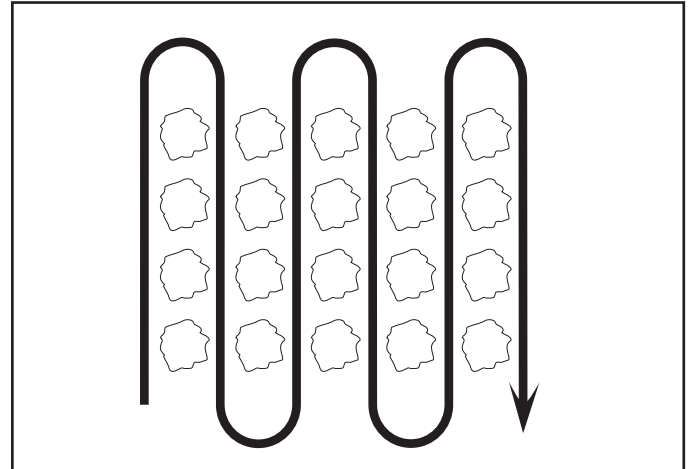

Fig. 16

TINE SHEAR PINS

The tine assemblies on your tiller are secured to the tine shaft with shear pins (See "TINE REPLACEMENT" in the Service and Adjustments section of this manual).

If the tiller is unusually overloaded or jammed, the shear pins are designed to break before internal damage occurs to the transmission.

- If shear pin(s) break, replace only with those shown in the Repair Parts section of this manual.

MAINTENANCE

MAINTENANCE SCHEDULE						SERVICE DATES															
	BEFORE EACH USE	EVERY 5 HOURS	EVERY 25 HOURS	EVERY 50 HOURS	EVERY SEASON																
FILL IN DATES AS YOU COMPLETE REGULAR SERVICE																					
Check Engine Oil Level	✓	✓																			
Change Engine Oil				✓ _{1,2}																	
Oil Pivot Points		✓																			
Inspect Spark Arrester / Muffler				✓																	
Inspect Air Screen	✓																				
Clean or Replace Air Cleaner Cartridge				✓ ₂																	
Clean Engine Cylinder Fins				✓																	
Replace Spark Plug				✓																	
RH Gear Case Grease Fitting (1oz.)					✓																

1 - Change more often when operating under a heavy load or in high ambient temperatures.
 2 - Service more often when operating in dirty or dusty conditions.

GENERAL RECOMMENDATIONS

The warranty on this tiller does not cover items that have been subjected to operator abuse or negligence. To receive full value from the warranty, the operator must maintain tiller as instructed in this manual.

Some adjustments will need to be made periodically to properly maintain your tiller.

All adjustments in the Service and Adjustments section of this manual should be checked at least once each season.

- Once a year you should replace the spark plug, clean or replace air filter, and check tines and belts for wear. A new spark plug and clean air filter assure proper air-fuel mixture and help your engine run better and last longer.

BEFORE EACH USE

- Check engine oil level.
- Check tine operation.
- Check for loose fasteners.

LUBRICATION

Keep unit well lubricated (See "LUBRICATION CHART").

LUBRICATION CHART

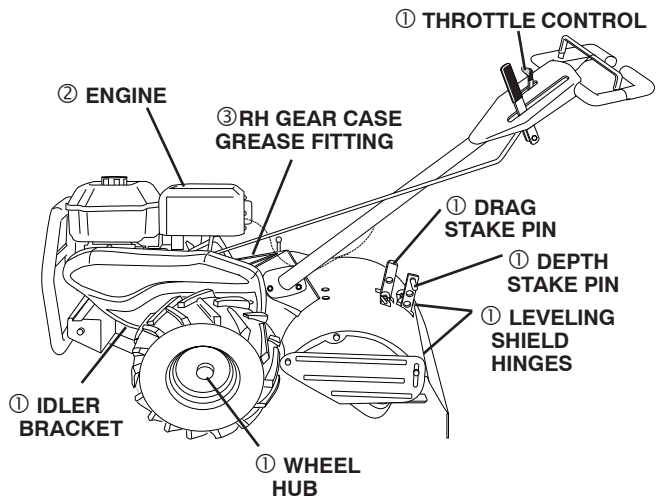

- ① SAE 30 OR 10W-30 MOTOR OIL
- ② REFER TO MAINTENANCE "ENGINE" SECTION
- ③ EP #1 GREASE

MAINTENANCE



Disconnect spark plug wire before performing any maintenance (except carburetor adjustment) to prevent accidental starting of engine. Prevent fires! Keep the engine free of grass, leaves, spilled oil, or fuel. Remove fuel from tank before tipping unit for maintenance. Clean muffler area of all grass, dirt, and debris. Do not touch hot muffler or cylinder fins as contact may cause burns.

ENGINE

LUBRICATION

Use only high quality detergent oil rated with API service classification SG-SL. Select the oil's SAE viscosity grade according to your expected temperature.

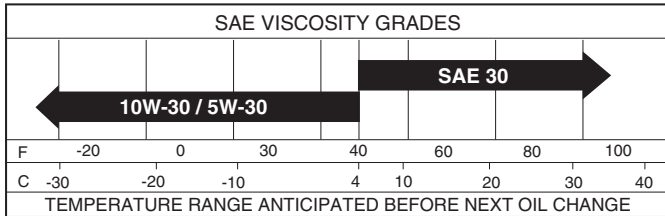

Fig. 17

NOTE: Although multi-viscosity oils (5W-30, 10W-30, etc.) improve starting in cold weather, these multi-viscosity oils will result in increased oil consumption when used above 32°F (0°C). Check your engine oil level more frequently to avoid possible engine damage from running low on oil.

Change the oil after every 50 hours of operation or at least once a year if the tiller is not used for 50 hours in one year.

Check the crankcase oil level before starting the engine and after each five (5) hours of continuous use. Add SAE 30 motor oil or equivalent. Tighten oil filler plug securely each time you check the oil level.

TO CHANGE ENGINE OIL (See Figs. 17 and 18)

Determine temperature range expected before oil change. All oil must meet API service classification SG-SL.

- Be sure tiller is on level surface.
- Oil will drain more freely when warm.
- Use a funnel to prevent oil spill on tiller, and catch oil in a suitable container.
- Remove drain plug. For easier removal of plug use 7/16 12 Pt. socket with extension.
- Tip tiller forward to drain oil.
- After oil has drained completely, replace oil drain plug and tighten securely.
- Remove oil filler plug.
- Refill engine with oil. See "CHECK ENGINE OIL LEVEL" in the Operation section of this manual.

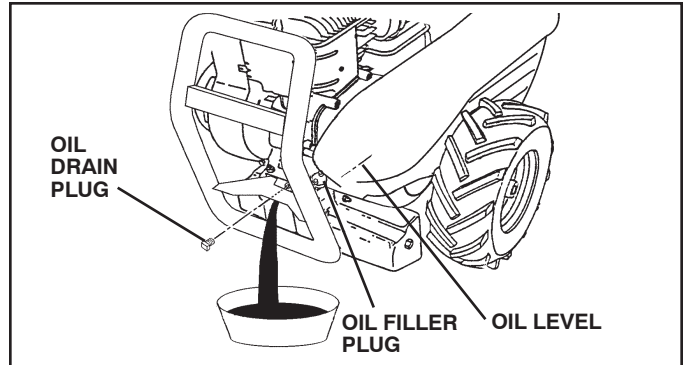

Fig. 18

AIR FILTER (See Fig. 19)

Your engine will not run properly using a dirty air filter. Clean the foam pre-cleaner after every 25 hours of operation or every season. Service paper cartridge every 100 hours of operation or every season, whichever occurs first.

Service air cleaner more often under dusty conditions.

- Remove cover screw and cover.

TO SERVICE PRE-CLEANER

- Remove foam pre-cleaner from air cleaner cover.
- Wash it in liquid detergent and water.
- Squeeze it dry in a clean cloth.
- If very dirty or damaged, replace pre-cleaner.
- Reinstall pre-cleaner into air cleaner cover.
- Reinstall cover and secure screw.

TO SERVICE CARTRIDGE

- Carefully remove cartridge to prevent debris from entering carburetor. Clean base carefully to prevent debris from entering carburetor.
- Clean cartridge by tapping gently on flat surface. If very dirty or damaged, replace cartridge.
- Reinstall cartridge, cover with pre-cleaner and secure with screw.

IMPORTANT: PETROLEUM SOLVENTS, SUCH AS KEROSENE, ARE NOT TO BE USED TO CLEAN THE CARTRIDGE. THEY MAY CAUSE DETERIORATION OF THE CARTRIDGE. DO NOT OIL CARTRIDGE. DO NOT USE PRESSURIZED AIR TO CLEAN OR DRY CARTRIDGE.

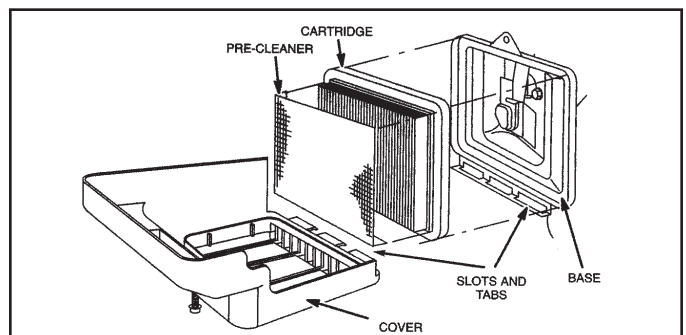

Fig. 19

MAINTENANCE

COOLING SYSTEM (See Fig. 20)

Your engine is air cooled. For proper engine performance and long life keep your engine clean.

- Clean air screen frequently using a stiff-bristled brush.
- Keep cylinder fins, levers, and linkage free of dirt and chaff.

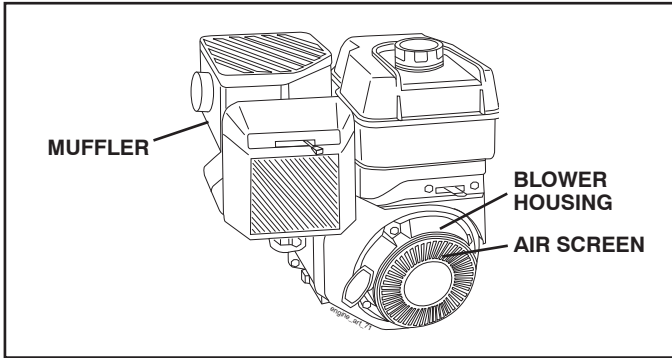

Fig. 20

MUFFLER

Do not operate tiller without muffler. Do not tamper with exhaust system. Damaged mufflers or spark arresters could create a fire hazard. Inspect periodically and replace if necessary. If your engine is equipped with a spark arrester screen assembly, remove every 50 hours for cleaning and inspection. Replace if damaged.

SPARK PLUG

Replace spark plugs at the beginning of each tilling season or after every 50 hours of use, whichever comes first. Spark plug type and gap setting is shown in "PRODUCT SPECIFICATIONS" on page 3 of this manual.

TRANSMISSION

Once a season, lubricate the right hand side gear case grease fitting with 1 oz. of EP #1 Grease.

CLEANING

Do not clean your tiller when the engine and transmission are hot. We do not recommend using pressurized water (garden hose, etc.) to clean your unit unless the gasket area around the transmission and the engine muffler, air filter and carburetor are covered to keep water out. Water in engine will shorten the useful life of your tiller.

- Clean engine, wheels, finish, etc. of all foreign matter.
- Keep finished surfaces and wheels free of all gasoline, oil, etc.
- Protect painted surfaces with automotive type wax.

SERVICE AND ADJUSTMENTS



CAUTION: Disconnect spark plug wire from spark plug and place wire where it cannot come into contact with plug.

TILLER

TO ADJUST HANDLE HEIGHT (See Fig. 21)

Select handle height best suited for your tilling conditions. Handle height will be different when tiller digs into soil.

- First loosen handle lock lever (Do not loosen too much or handle locks may fall out).
- Handle can be positioned at different settings between "HIGH" and "LOW" positions.
- Retighten handle lock lever securely after adjusting.

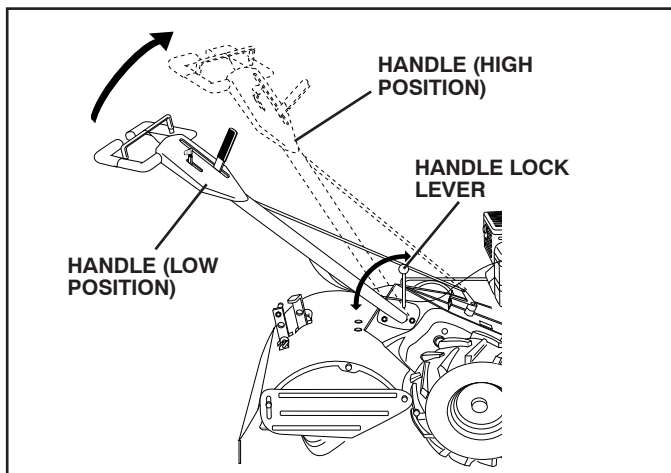

Fig. 21

TIRE CARE



CAUTION: When mounting tires, unless beads are seated, overinflation can cause an explosion.

- Maintain 20 pounds of tire pressure. If tire pressures are not equal, tiller will pull to one side.
- Keep tires free of gasoline or oil which can damage rubber.

TO REMOVE WHEEL (See Fig. 22)

- Place blocks under transmission to keep tiller from tipping.
- Remove hairpin clip and clevis pin from wheel.
- Remove wheel and tire.
- Repair tire and reassemble.

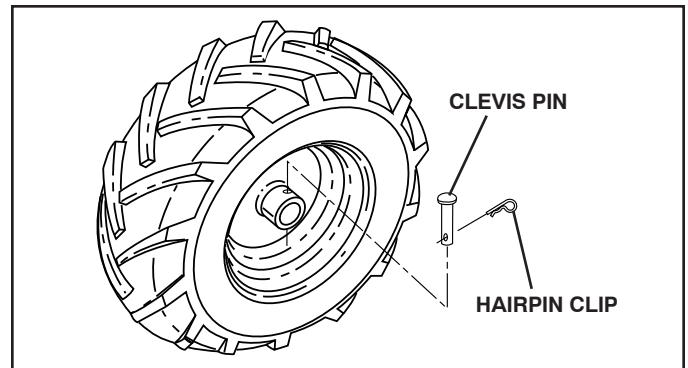

Fig. 22

TO REMOVE BELT GUARD (See Fig. 23)

NOTE: For ease of removal, remove hairpin clip and clevis pin from left wheel. Pull wheel out from tiller about 1 inch.

- Remove two (2) screws, one (1) nut and washer from side of belt guard.
- Pull belt guard out and away from unit.
- Replace belt guard by reversing above procedure.

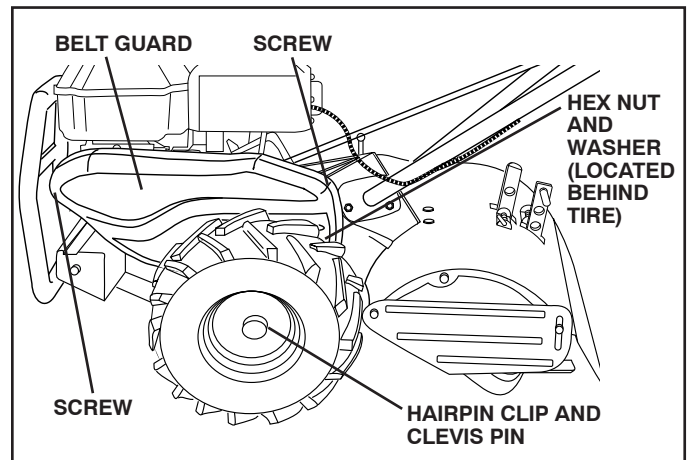

Fig. 23

SERVICE AND ADJUSTMENTS

TO REPLACE GROUND DRIVE BELT (See Figs. 23 and 24)

- Remove belt guard as described in "TO REMOVE BELT GUARD".
- Remove old belt by slipping off engine pulley first then remove from transmission pulley.
- Place new belt in groove of transmission pulley and into engine pulley. BELT MUST BE IN GROOVE ON TOP OF IDLER PULLEY. NOTE POSITION OF BELT TO GUIDES.
- Check belt adjustment as described below.
- Replace belt guard.
- Reposition wheel and replace clevis pin and hairpin clip.

GROUND DRIVE BELT ADJUSTMENT (See Fig. 24)

For proper belt tension, the extension spring should have about 5/8 inch (16 mm) stretch when drive control bar is in "ENGAGED" position. This tension can be attained as follows:

- Loosen cable clip screw securing the drive control cable.
- Slide cable forward for less tension and rearward for more tension until about 5/8 inch (16 mm) stretch is obtained while the drive control bar is engaged.
- Tighten cable clip screw securely.

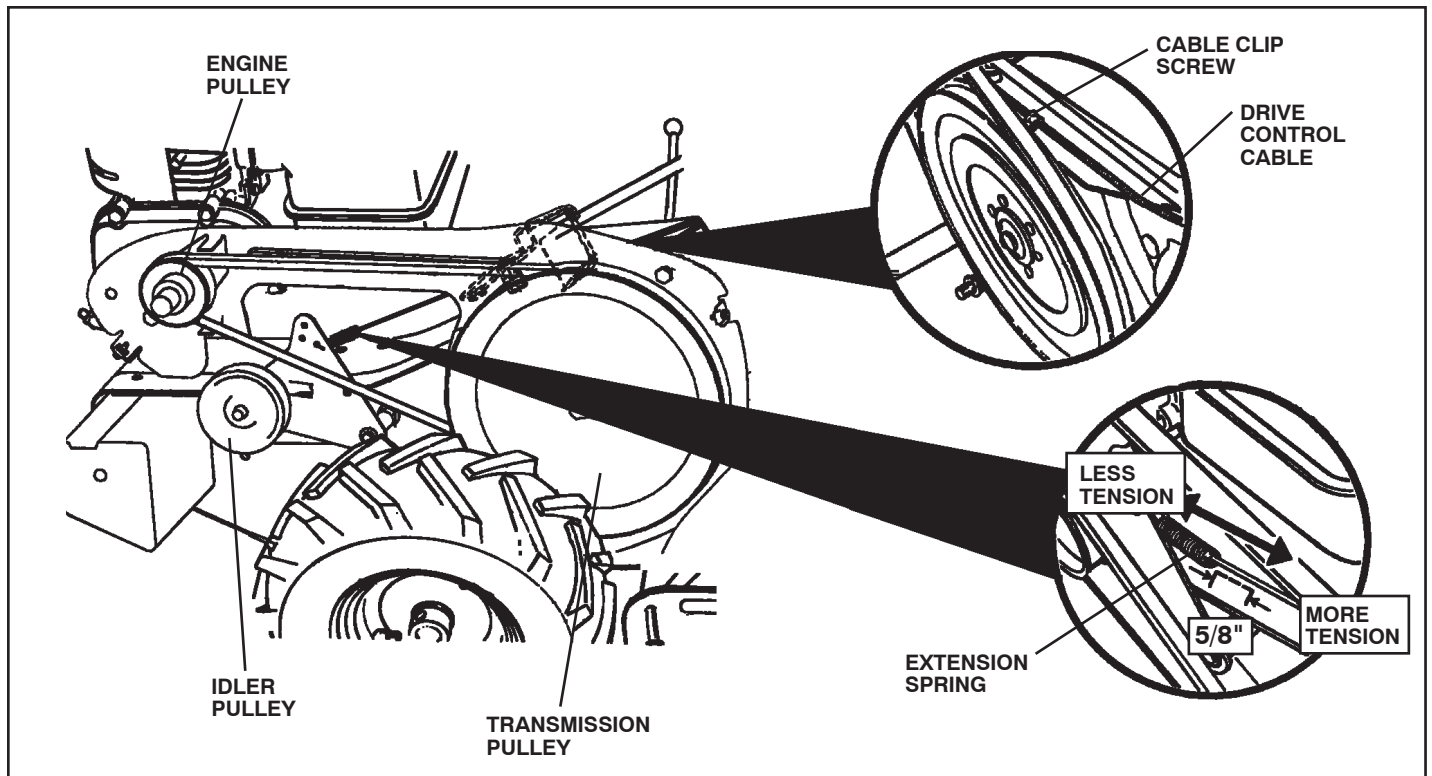

Fig. 24

SERVICE AND ADJUSTMENTS

TINE REPLACEMENT

(See Figs. 25, 26 and 27)



CAUTION: Tines are sharp. Wear gloves or other protection when handling tines.

A badly worn tine causes your tiller to work harder and dig more shallow. Most important, worn tines cannot chop and shred organic matter as effectively nor bury it as deeply as good tines. A tine this worn needs to be replaced.

- To maintain the superb tilling performance of this machine the tines should be checked for sharpness, wear, and bending, particularly the tines which are next to the transmission. If the gap between the tines exceeds 3-1/2 inches (9 cm), they should be replaced or straightened as necessary.
- For tines that are slightly worn, the bolted tine and hub assemblies can be switched between sides to continue tilling in the same tilling mode. If tilling in different mode is desired then the bolted tine and hub assemblies should be switched back to their original side so that the tine edge with the least wear will be used.

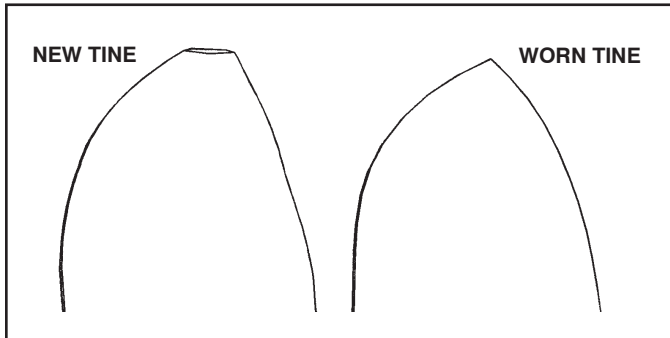

Fig. 25

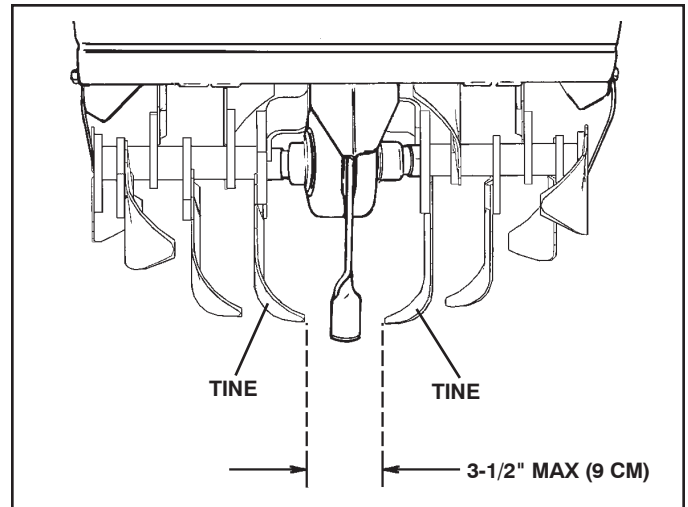

Fig. 26

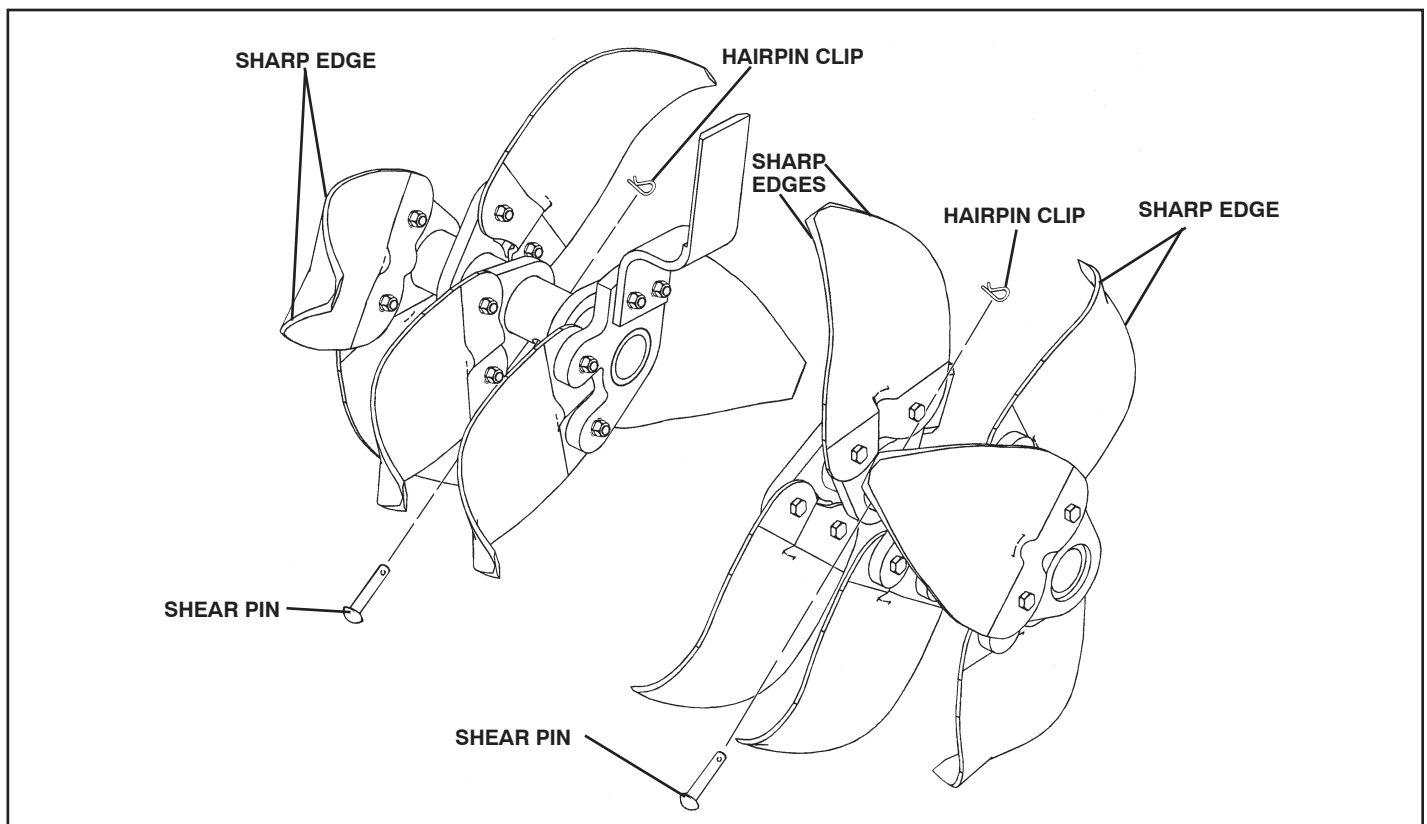

Fig. 27

SERVICE AND ADJUSTMENTS

ENGINE

Maintenance, repair, or replacement of the emission control devices and systems, which are being done at the customer's expense, may be performed by any non-road engine repair establishment or individual. Warranty repairs must be performed by an authorized engine manufacturer's service outlet.

TO ADJUST THROTTLE CONTROL CABLE (See Fig. 28)

The throttle control has been preset at the factory and adjustment should not be necessary. If adjustment is necessary, proceed as follows:

- With engine not running, move remote throttle control lever to "FAST" position.
- If throttle lever on engine touches high speed stop, no further adjustment is necessary. If throttle lever does not touch high speed stop, continue with adjustment procedure.
- Loosen cable clamp screw.
- Move throttle lever up until it touches high speed stop, and hold in this position.
- Tighten cable clamp screw securely.

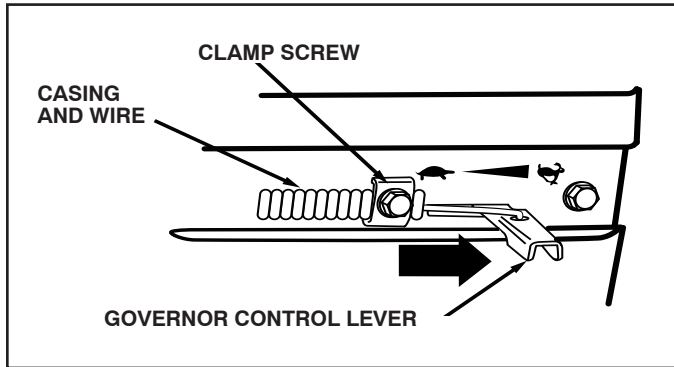

Fig. 28

TO ADJUST CARBURETOR

The carburetor has a high speed jet and has been preset at the factory and adjustment should not be necessary. However, minor adjustments may be required to compensate for differences in fuel, temperature, altitude or load. If the carburetor does need adjustment, proceed as follows.

High speed stop is factory adjusted. Do not adjust or damage may result.

IMPORTANT: NEVER TAMPER WITH THE ENGINE GOVERNOR, WHICH IS FACTORY SET FOR PROPER ENGINE SPEED. OVERSPEEDING THE ENGINE ABOVE THE FACTORY HIGH SPEED SETTING CAN BE DANGEROUS. IF YOU THINK THE ENGINE-GOVERNED HIGH SPEED NEEDS ADJUSTING, CONTACT YOUR NEAREST AUTHORIZED SERVICE CENTER/DEPARTMENT, WHICH HAS THE PROPER EQUIPMENT AND EXPERIENCE TO MAKE ANY NECESSARY ADJUSTMENTS.

STORAGE

Immediately prepare your tiller for storage at the end of the season or if the unit will not be used for 30 days or more.



WARNING: Never store the tiller with gasoline in the tank inside a building where fumes may reach an open flame or spark. Allow the engine to cool before storing in any enclosure.

TILLER

- Clean entire tiller (See “CLEANING” in the Maintenance section of this manual).
- Inspect and replace belts, if necessary (See belt replacement instructions in the Service and Adjustments section of this manual).
- Lubricate as shown in the Maintenance section of this manual.
- Be sure that all nuts, bolts and screws are securely fastened. Inspect moving parts for damage, breakage and wear. Replace if necessary.
- Touch up all rusted or chipped paint surfaces; sand lightly before painting.

ENGINE

FUEL SYSTEM

IMPORTANT: IT IS IMPORTANT TO PREVENT GUM DEPOSITS FROM FORMING IN ESSENTIAL FUEL SYSTEM PARTS SUCH AS THE CARBURETOR, FUEL FILTER, FUEL HOSE, OR TANK DURING STORAGE. ALSO, EXPERIENCE INDICATES THAT ALCOHOL BLENDED FUELS (CALLED GASOHOL OR USING ETHANOL OR METHANOL) CAN ATTRACT MOISTURE WHICH LEADS TO SEPARATION AND FORMATION OF ACIDS DURING STORAGE. ACIDIC GAS CAN DAMAGE THE FUEL SYSTEM OF AN ENGINE WHILE IN STORAGE.

- Drain the fuel tank.
- Start the engine and let it run until the fuel lines and carburetor are empty.
- Never use engine or carburetor cleaner products in the fuel tank or permanent.

NOTE: Fuel stabilizer is an acceptable alternative in minimizing the formation of fuel gum deposits during storage. Add stabilizer to gasoline in fuel tank or storage container. Always follow the mix ratio found on stabilizer container. Run engine at least 10 minutes after adding stabilizer to allow the stabilizer to reach the carburetor. Do not drain the gas tank and carburetor if using fuel stabilizer.

ENGINE OIL

Drain oil (with engine warm) and replace with clean oil. (See “ENGINE” in the Maintenance section of this manual).

CYLINDER(S)

- Remove spark plug.
- Pour 1 ounce (29 ml) of oil through spark plug hole into cylinder.
- Pull starter handle slowly several times to distribute oil.
- Replace with new spark plug.

OTHER

- Do not store gasoline from one season to another.
- Replace your gasoline can if your can starts to rust. Rust and/or dirt in your gasoline will cause problems.
- If possible, store your unit indoors and cover it to give protection from dust and dirt.
- Cover your unit with a suitable protective cover that does not retain moisture. Do not use plastic. Plastic cannot breathe which allows condensation to form and will cause your unit to rust.

IMPORTANT: NEVER COVER TILLER WHILE ENGINE AND EXHAUST AREAS ARE STILL WARM.

TROUBLESHOOTING POINTS

PROBLEM	CAUSE	CORRECTION
Will not start	<ol style="list-style-type: none"> 1. Out of fuel. 2. Engine not "CHOKED" properly. 3. Engine flooded. 4. Dirty air cleaner. 5. Water in fuel. 6. Clogged fuel tank. 7. Loose spark plug wire. 8. Bad spark plug or improper gap. 9. Carburetor out of adjustment. 10. Fuel shut-off valve is closed. 	<ol style="list-style-type: none"> 1. Fill fuel tank. 2. See "TO START ENGINE" in Operation section. 3. Wait several minutes before attempting to start. 4. Clean or replace air cleaner cartridge. 5. Drain fuel tank and carburetor, and refill tank with fresh gasoline. 6. Remove fuel tank and clean. 7. Make sure spark plug wire is seated properly on plug. 8. Replace spark plug or adjust gap. 9. Make necessary adjustments. 10. Open valve.
Hard to start	<ol style="list-style-type: none"> 1. Throttle control not set properly. 2. Dirty air cleaner. 3. Bad spark plug or improper gap. 4. Stale or dirty fuel. 5. Loose spark plug wire. 6. Carburetor out of adjustment. 	<ol style="list-style-type: none"> 1. Place throttle control in "FAST" position. 2. Clean or replace air cleaner cartridge. 3. Replace spark plug or adjust gap. 4. Drain fuel tank and refill with fresh gasoline. 5. Make sure spark plug wire is seated properly on plug. 6. Make necessary adjustments.
Loss of power	<ol style="list-style-type: none"> 1. Engine is overloaded. 2. Dirty air cleaner. 3. Low oil level/dirty oil. 4. Faulty spark plug. 5. Oil in fuel. 6. Stale or dirty fuel. 7. Water in fuel. 8. Clogged fuel tank. 9. Spark plug wire loose. 10. Dirty engine air screen. 11. Dirty/clogged muffler. 12. Carburetor out of adjustment. 13. Poor compression. 	<ol style="list-style-type: none"> 1. Set depth stake for shallower tilling. 2. Clean or replace air cleaner cartridge. 3. Check oil level/change oil. 4. Clean and regap or change spark plug. 5. Drain and clean fuel tank and refill, and clean carburetor. 6. Drain fuel tank and refill with fresh gasoline. 7. Drain fuel tank and carburetor, and refill tank with fresh gasoline. 8. Remove fuel tank and clean. 9. Connect and tighten spark plug wire. 10. Clean engine air screen. 11. Clean/replace muffler. 12. Make necessary adjustments. 13. Contact an authorized service center/department.
Engine overheats	<ol style="list-style-type: none"> 1. Low oil level/dirty oil. 2. Dirty engine air screen. 3. Dirty engine. 4. Partially plugged muffler. 5. Improper carburetor adjustment. 	<ol style="list-style-type: none"> 1. Check oil level/change oil. 2. Clean engine air screen. 3. Clean cylinder fins, air screen, and muffler area. 4. Remove and clean muffler. 5. Adjust carburetor to richer position.
Excessive bounce/ difficult handling	<ol style="list-style-type: none"> 1. Ground too dry and hard. 	<ol style="list-style-type: none"> 1. Moisten ground or wait for more favorable soil conditions.
Soil balls up or clumps	<ol style="list-style-type: none"> 1. Ground too wet. 	<ol style="list-style-type: none"> 1. Wait for more favorable soil conditions.
Engine runs but tiller won't move	<ol style="list-style-type: none"> 1. Drive control bar is not engaged. 2. V-belt not correctly adjusted. 3. V-belt is off pulley(s). 	<ol style="list-style-type: none"> 1. Engage drive control. 2. Inspect/adjust V-belt. 3. Inspect V-belt.
Engine runs but labors when tilling	<ol style="list-style-type: none"> 1. Tilling too deep. 2. Throttle control not properly adjusted. 3. Carburetor out of adjustment. 	<ol style="list-style-type: none"> 1. Set depth stake for shallower tilling. 2. Check throttle control setting. 3. Make necessary adjustments.
Tines skip over ground	<ol style="list-style-type: none"> 1. Drag Stake not lowered in forward rotating till mode. 	<ol style="list-style-type: none"> 1. Lower Drag Stake.
Hard to shift into gear	<ol style="list-style-type: none"> 1. Gears not timed. 	<ol style="list-style-type: none"> 1. Rock tiller forward and backward until are able to shift.
Tiller shuts off when drive control bar engaged	<ol style="list-style-type: none"> 1. Shift lever set in between counter rotating till position and forward rotating till position. 2. Tines Jammed. 	<ol style="list-style-type: none"> 1. Shift to either counter rotating till position or forward rotating till position. 2. Clear tines.

REPAIR PARTS

TILLER - - MODEL NUMBER 944.629672

HANDLES

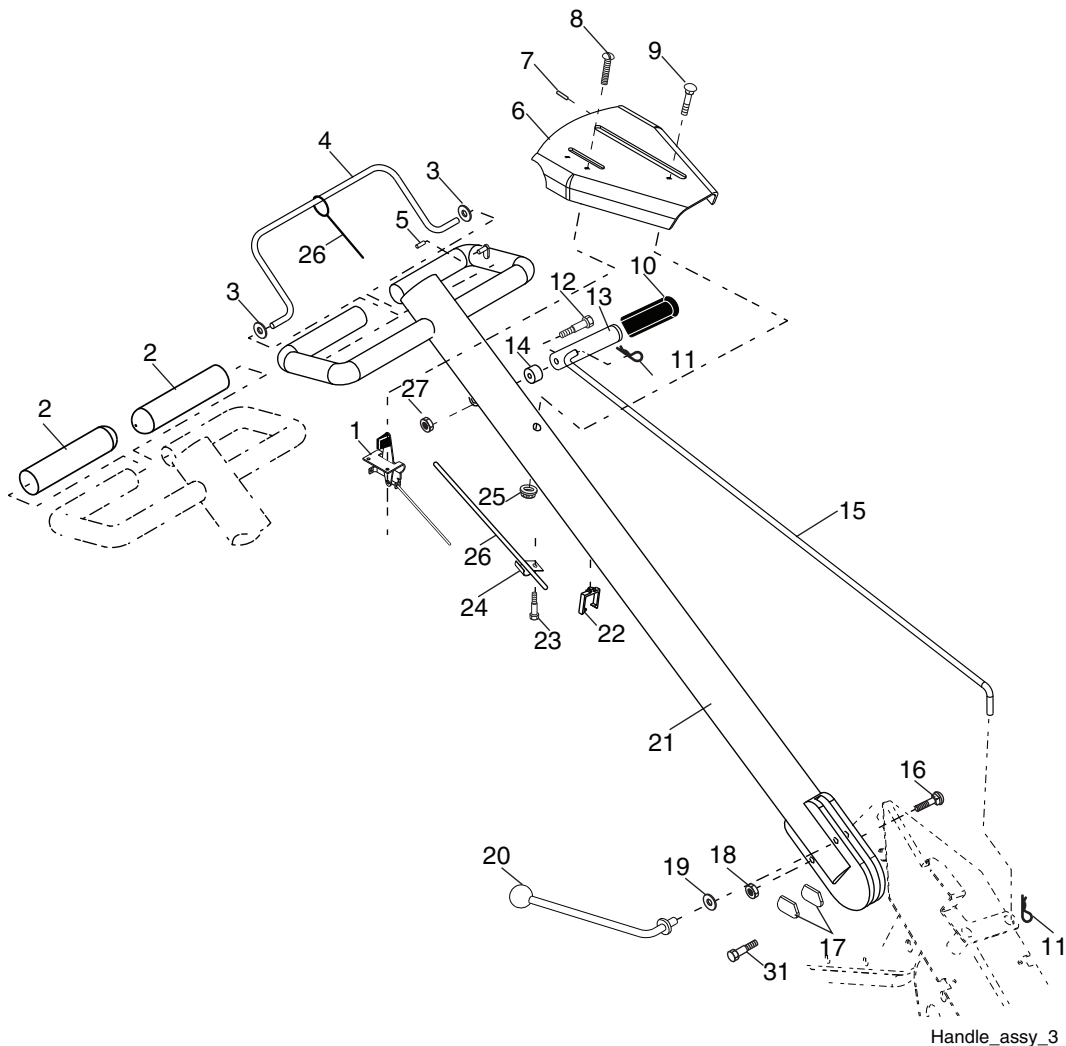

Handle_assy_3

KEY NO.	PART NO.	DESCRIPTION	KEY NO.	PART NO.	DESCRIPTION
1	189482	Throttle, Control	17	109229X	Lock, Handle
2	141406	Grip, Handle	18	STD541437	Nut, Crownlock 3/8-16
3	110673X	Grommet, Handle	19	19131611	Washer 13/32 x 1 x 11 Ga.
4	127254X	Bar, Assembly Control	20	109228X	Lever, Lock, Handle
5	6712J	Cap, Vinyl	21	420524	Column, Handle, Asm.
6	188403	Panel, Control	22	165197	Clip, Plastic, Cable
7	110641X	Bushing, Split	23	86777	Screw, Hex, Washer #10-24 x 1/2
8	17720408	Screw 1/4-20 x 1/2	24	9484R	Clip
9	72010520	Bolt, 5/16-18 x 2.50	25	73970500	Locknut, Hex, Flange
10	110646X	Handle, Grip	26	110675X	Clutch, Cable
11	STD624003	Retainer Spring	27	73900400	Nut, Hex Flange 1/4-20 UNC
12	81328	Bolt, Shoulder	31	150696	Bolt, Pivot
13	187497	Handle, Shift			
14	109313X	Grommet, Rubber			
15	110702X	Rod, Shift			
16	STD533710	Bolt, Carriage 3/8-16 x 1 Gr. 5			

NOTE: All component dimensions given in U.S. inches.
1 inch = 25.4 mm

REPAIR PARTS

TILLER - - MODEL NUMBER 944.629672

MAINFRAME, LEFT SIDE

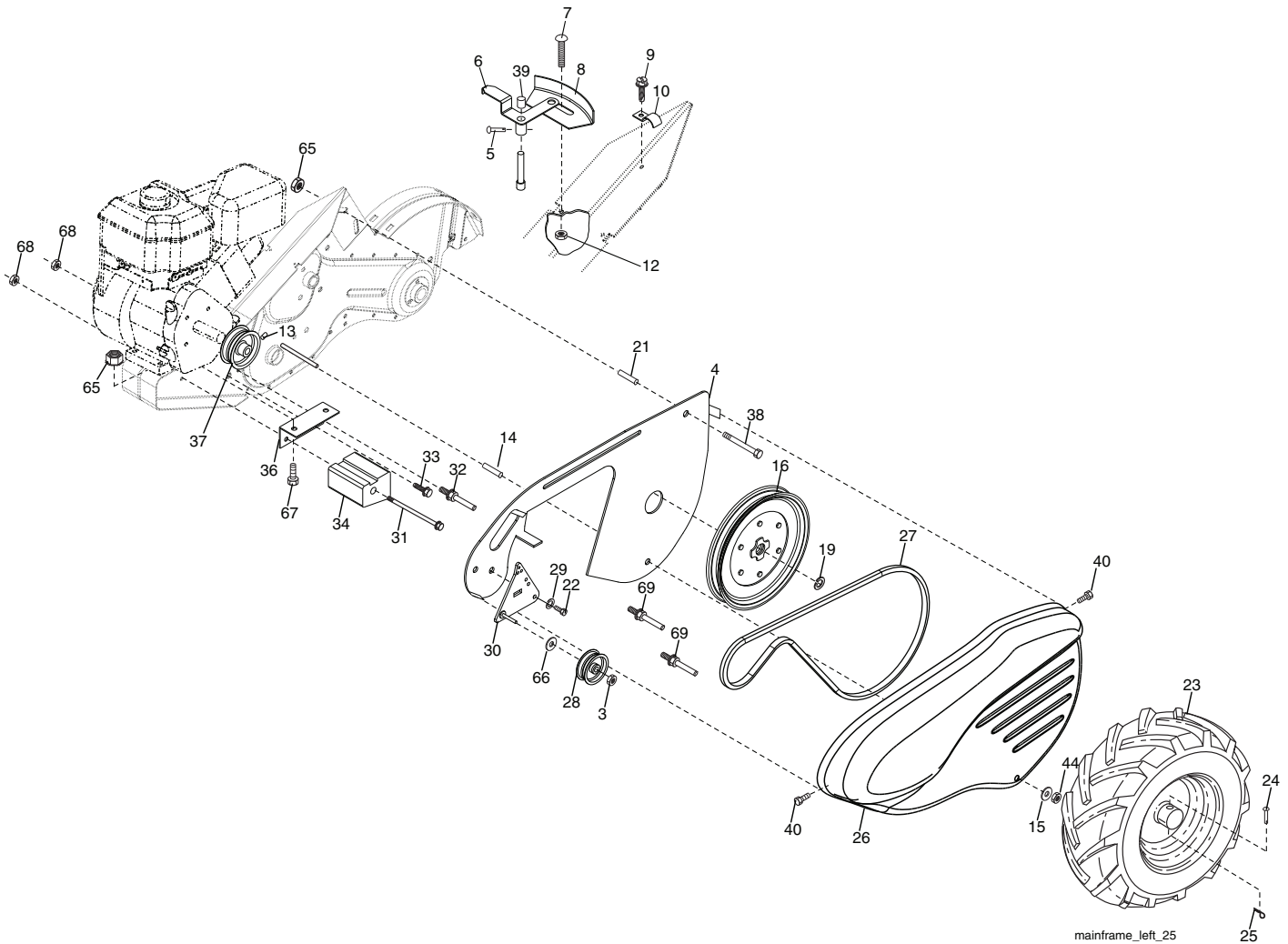

KEY NO.	PART NO.	DESCRIPTION
3	73220600	Nut Hex 3/8-16
4	432420	Shield Inner Belt Guard
5	164329	Pin, Shift Lever
6	162756	Lever, Shift
7	STD532505	Bolt, Carriage 1/4-20 x 1/2 Gr. 5
8	161530	Plate, Shift Indicator
9	86777	Screw, Hex, Washer Head, Slotted #10-24 x 1/2
10	9484R	Clip
12	73510400	Nut, Keps 1/4-20
13	23230506	Screw, Set, Hex 5/16-18 x 3/8
14	156117	Spacer, Split 0.327 x 0.42 x 1.220
15	STD551031	Washer 11/32 x 11/16 x 16 Ga.
16	145102	Sheave, Transmission
19	12000028	Ring, Retainer
21	110652X	Spacer, Split 0.327 x 0.42 x 2.09
22	74770508	Bolt Hex 5/16-2-1/2
23	102190X	Tire
	183122X613	Rim
	795R	Tire Valve
24	126875X	Rivet, Drilled
25	STD624003	Clip, Hairpin
26	165501X428	Guard, Belt

KEY NO.	PART NO.	DESCRIPTION
27	132801	Belt, V
28	104679X	Pulley, Idler
29	12000032	Ring, Klip
30	159229	Bracket, Idler
31	102384X	Bolt, Hex 5/16-16 x 12
32	102141X	Shaft, Idler Arm
33	STD523710	Bolt, Hex 3/8-16 x 1
34	102383X	Counterweight, L. H.
36	102331X	Bracket, Reinforcement, L. H.
37	130812	Sheave, Engine
38	74760544	Bolt Hex 5/16-18 x 2-3/4
39	140062	Cap, Plunger
40	170488	Screw Hex Wsh Slit #10-24 x .50
44	73800500	Nut, Lock Hex 5/16-18
65	73970500	Nut, Hex Flange
66	19131312	Washer 13/32 x 13/16 x 12 Ga.
67	74760524	Bolt Hex 5/16-18 x 18 x 1-3/4
68	STD541437	Nut, Keps 3/8-16 unc
69	164173	Keeper Belt Engine

NOTE: All component dimensions given in U.S. inches.
1 inch = 25.4 mm

REPAIR PARTS

TILLER - - MODEL NUMBER 944.629672

MAINFRAME, RIGHT SIDE

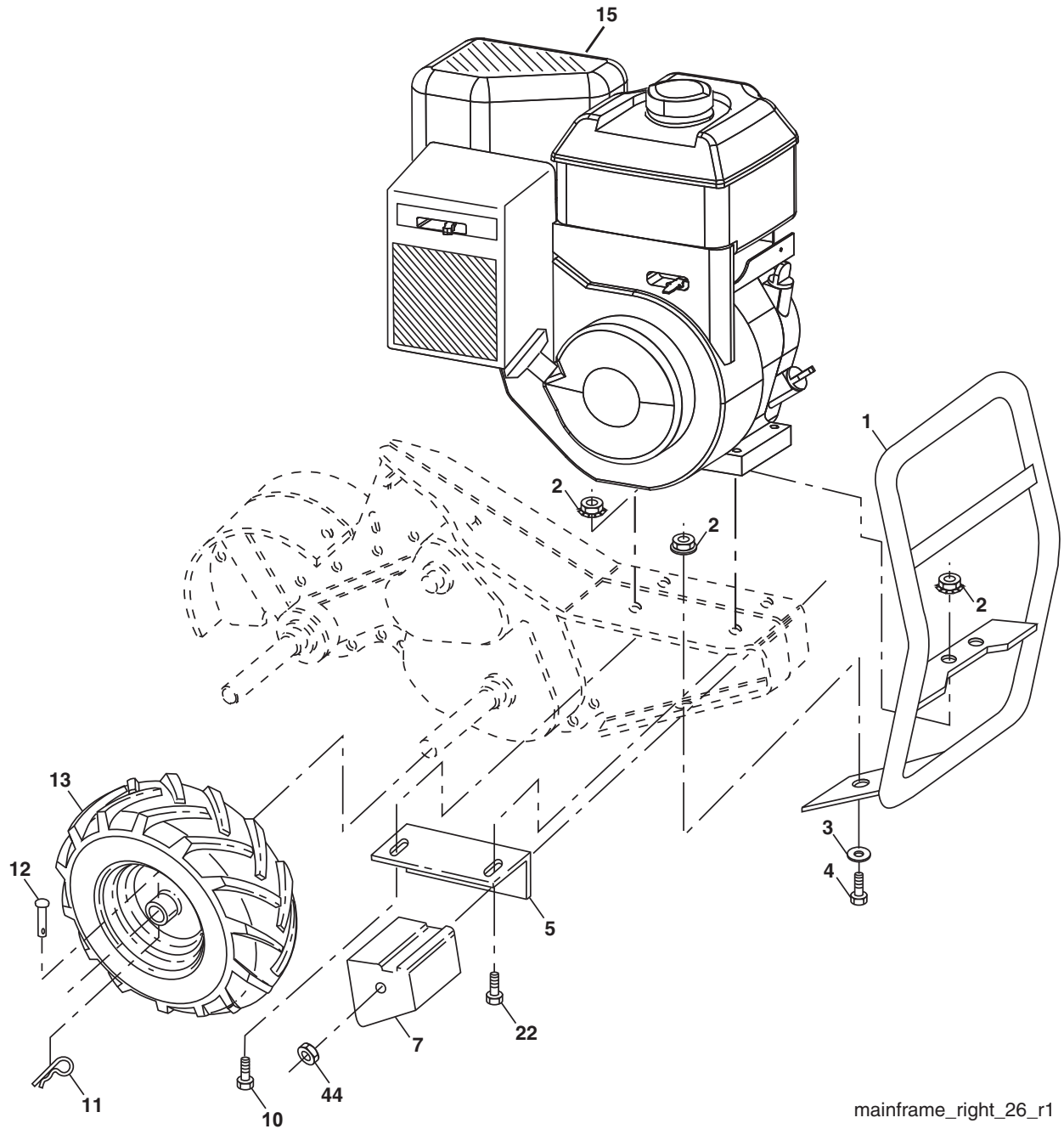

mainframe_right_26_r1

KEY NO.	PART NO.	DESCRIPTION
1	185190	Bumper
2	73970500	Locknut, Hex, Flange 5/16-18
3	STD551031	Washer 11/32 x 11/16 x 16 Ga.
4	74760512	Bolt, Hex 5/16-18 x 3/4
5	102332X	Bracket, Reinforcement
7	102173X	Counter Weight, R.H.
10	74760524	Bolt, Hex 5/16-18 x 1-1/2
11	STD624003	Clip, Hairpin
12	126875X	Rivet, Drilled

KEY NO.	PART NO.	DESCRIPTION
13	102190X	Tire
	183122X613	Rim
	795R	Tire Valve
15	-----	Engine(See breakdown) Briggs Model 121002-1383-B8
22	74760528	Bolt, Fin Hex 5/16-18 Unc x 1-3/4
44	STD541437	Nut, Keps, Hex 3/8-16 unc

NOTE: All component dimensions given in U.S.inches.
1 inch = 25.4 mm

REPAIR PARTS

TILLER - - MODEL NUMBER 944.629672

TRANSMISSION

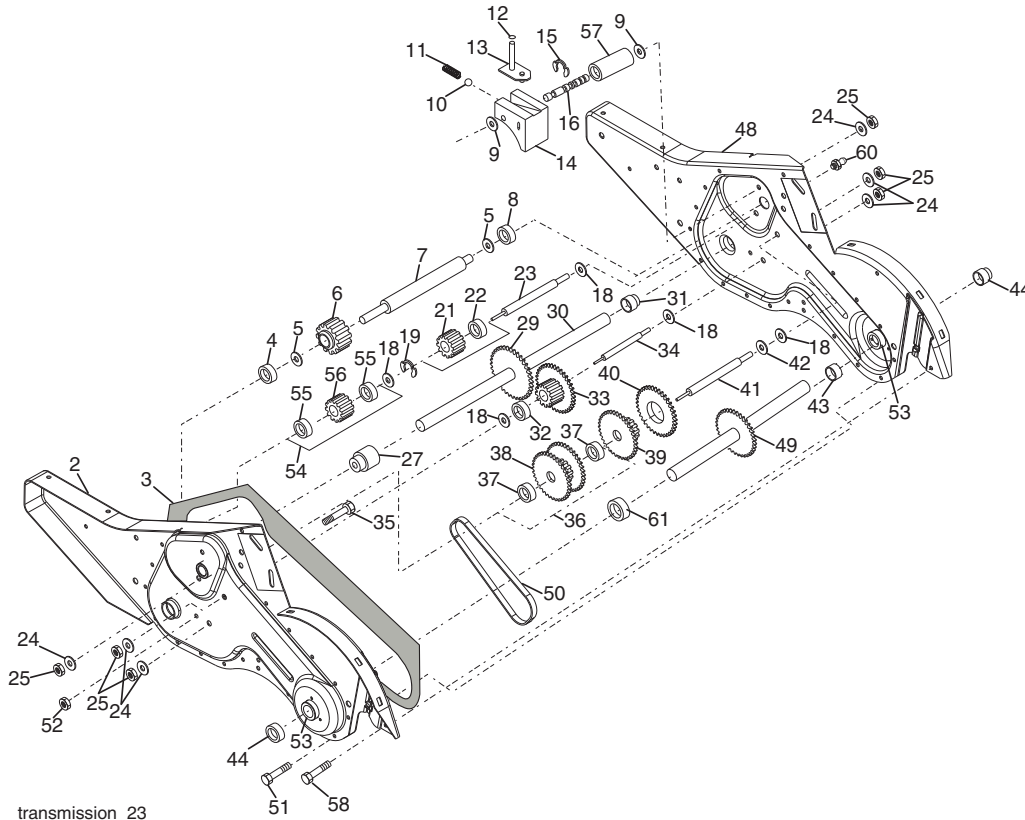

transmission_23

KEY NO.	PART NO.	DESCRIPTION	KEY NO.	PART NO.	DESCRIPTION
1	188240	Transmission Assembly	33	102121X	Sprocket and Gear Assembly
2	188220	Gearcase, L.H. w/Bearing (Includes Key No. 4)	34	102112X	Shaft, Reduction (2nd)
3	431022	Gasket, Gearcase	35	102101X	Screw, Whiz, Lock 5/16-18 x 3-1/2
4	5020J	Bearing, Needle	36	161524	Sprocket Assembly w/Bearing (Includes Key Nos. 37 and 38)
5	1370H	Washer, Thrust 5/8 x 1.10 x 1/32	37	100413K	Bearing, Needle
6	161520	Pinion, Input	38	161525	Sprocket, Tine
7	161518	Shaft, Input	39	161526	Gear, Cluster, Red 1st & 2nd
8	4895H	Bearing, Needle	40	105346X	Gear, Reverse
9	154467	Washer, Seal	41	161523	Shaft, Reduction (1st)
10	7392M	Ball, Steel	42	4220R	Washer, Thrust
11	100371K	Spring, Shift, Fork	43	106146X	Spacer 1.01 x 1.75 x 0.760
12	106160X	O-Ring	44	155236	Seal Asm Oil
13	142145	Arm, Shift	48	188235	Gearcase, R.H. w/Bearing (Includes Key No. 8)
14	8353J	Fork, Shift	49	431485	Shaft, Tine
15	12000039	Ring, Klip	50	106147X	Chain, Roller #50-50 Pitch
16	161516	Shaft, Shift	51	17720408	Screw 1/4-20 x 1/2
18	4358J	Washer	52	73220500	Nut, Hex 5/16-18
19	12000040	Ring, Klip	53	165140	Kit, Bearing
20	102114X	Gear, Assembly, Reverse Idler (Includes Key Nos. 21 and 22)	54	161528	Gear, DRT Idler (Includes Key # 55)
21	102115X	Gear, Reverse Idler	55	3400R	Bearing, Needle
22	6803J	Bearing, Needle	56	161529	Gear, DRT Idler
23	161527	Shaft, Reverse Idler	57	165889	Spacer, Split .52 x .64 x 1.04
24	STD551143	Washer, Lock 7/16	58	179520	Bolt, Shoulder 7/8
25	STD541143	Nut, Hex 7/16-20	60	183266	Fitting Grease
27	431219	Bearing, Shaft, Ground Drive L.H.	61	431015	Spacer 1.015 x 1.50 x .650
29	102134X	Chain #35-50 Pitch	--	6066J	Grease, Plastilube #1
30	150737	Ground Shaft Assembly			
31	143008	Bearing, Shaft, Ground Drive R.H.			
32	106388X	Spacer 0.70 x 1.00 x 1.150			

NOTE: All component dimensions given in U.S. inches.
1 inch = 25.4 mm

REPAIR PARTS

TILLER - - MODEL NUMBER 944.629672

TINE SHIELD

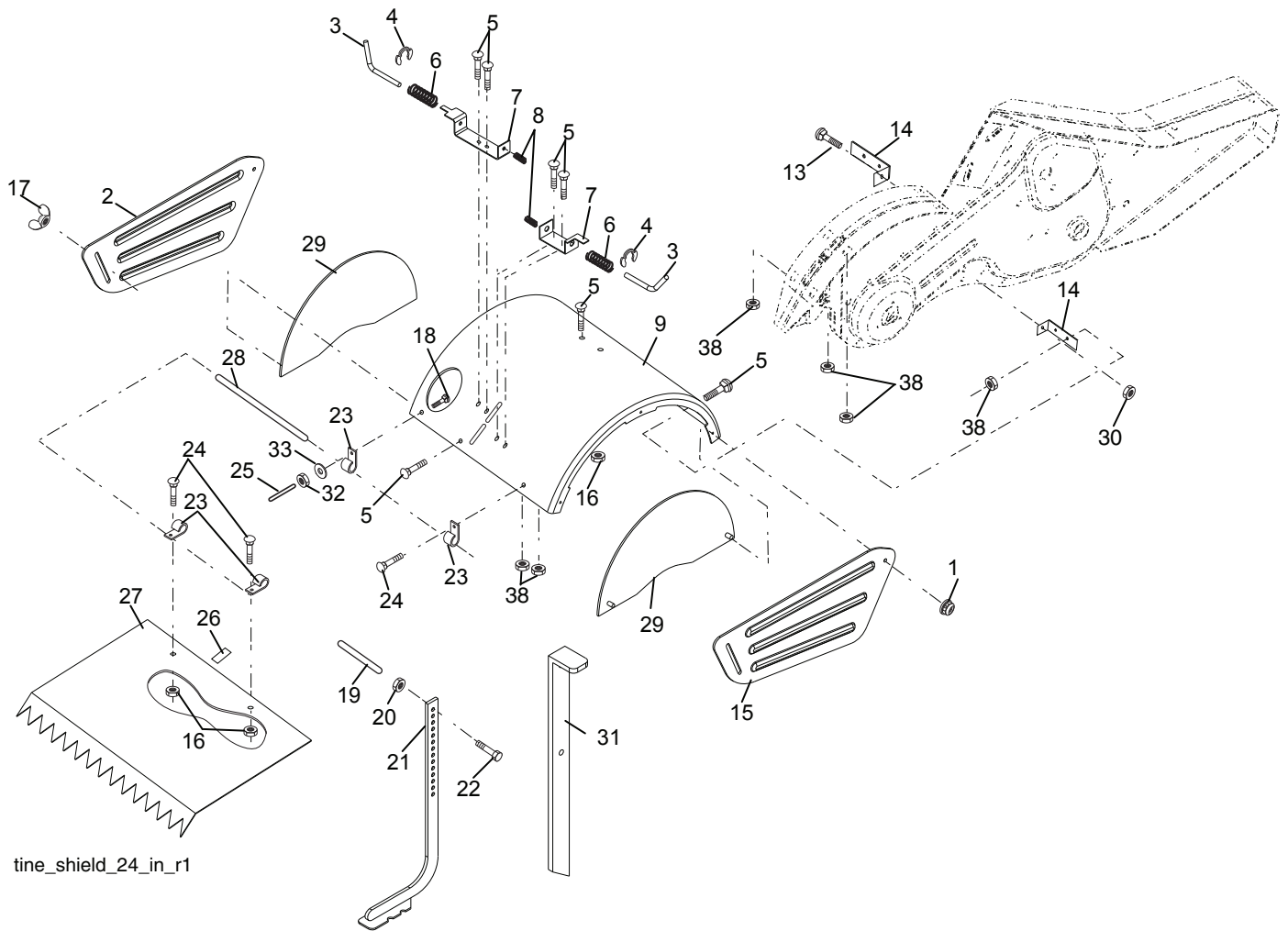

tine_shield_24_in_r1

KEY NO.	PART NO.	DESCRIPTION
1	73900500	Nut, Lock, Hex, Flange 5/16-18
2	161415X428	Shield, Side, Outer L. H.
3	8393J	Pin, Stake, Depth
4	12000035	Ring, Klip
5	180847	Bolt 5/16-18 x 3/4
6	8394J	Spring
7	8392J	Bracket, Latch
8	109230X	Spring, Depth Stake
9	188862X428	Shield, Tine
13	72110510	Bolt, Carriage 5/16-18 x 1-1/4
14	124343X	Bracket, Shield Tine
15	161414X428	Shield, Side, Outer R.H.
16	73900400	Nut, Hex, Flange
17	162175	Nut, Wing Forged 5/16-18
18	STD532512	Bolt, Carriage 1/4-20 x 1-1/4 Gr. 5
19	102701X	Grip
20	STD541037	Nut, Hex 3/8-16

KEY NO.	PART NO.	DESCRIPTION
21	102156X	Stake, Depth
22	74930632	Bolt, Hex 3/8-16 x 2
23	4440J	Hinge
24	72140404	Bolt, Carriage 1/4-20 x 1/2 Gr. 5
25	6712J	Cap, Vinyl
26	109227X	Pad, Idler
27	102695X428	Shield, Leveling
28	120588X	Pin, Hinge
29	197761X428	Shield, Side
30	73970500	Nut Lock Hex Flange
31	163498X613	Stake, Drag
32	73220400	Nut, Fin, Hex 1/4-20 UNC
33	10040400	Washer Lock Hvy Helical 1/4
38	STD541431	Nut, Keps, Hex 5/16-18 unc

NOTE: All component dimensions given in U.S. inches.
1 inch = 25.4 mm

REPAIR PARTS

TILLER - - MODEL NUMBER 944.629672

TINE ASSEMBLY

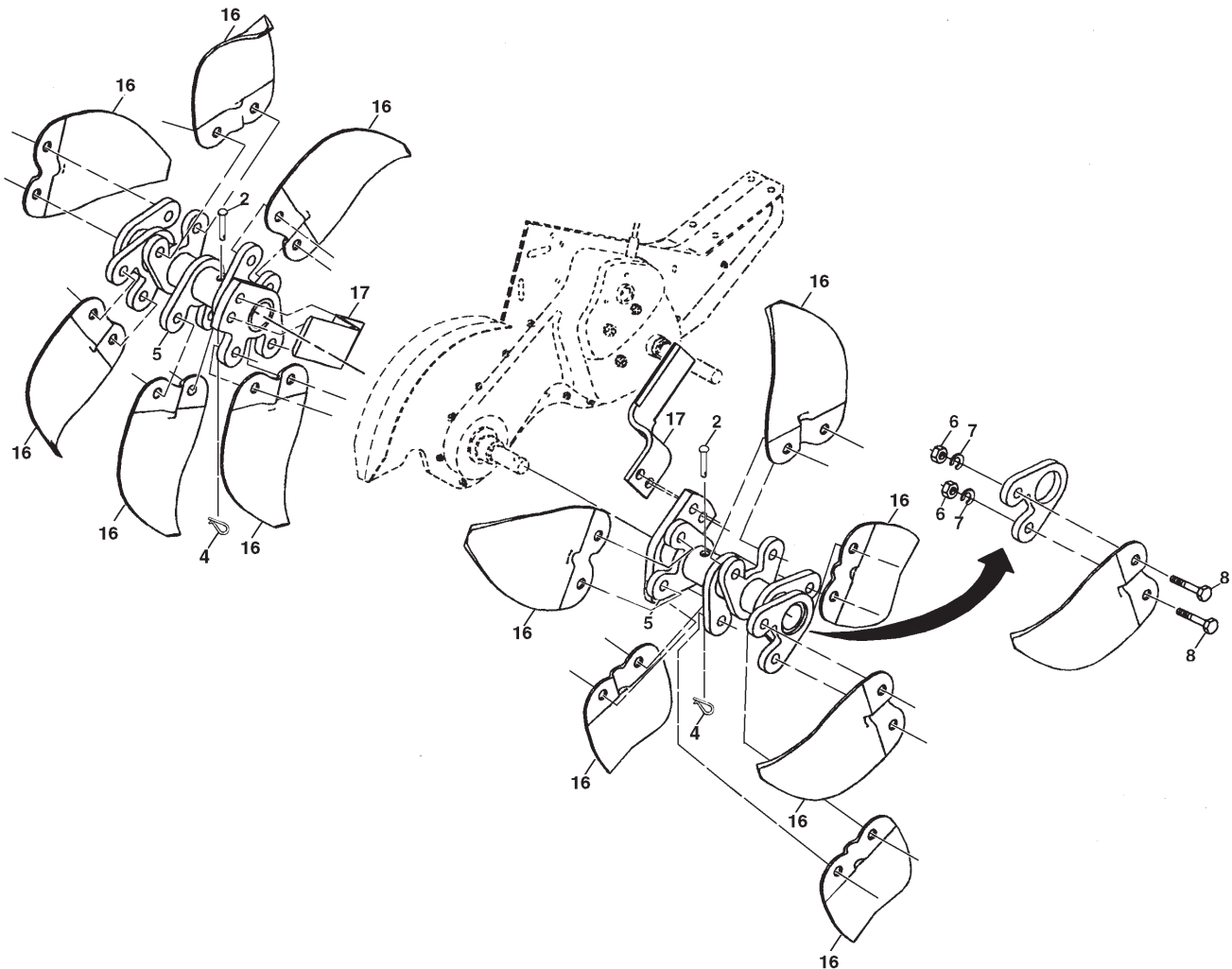

KEY NO.	PART NO.	DESCRIPTION
2	132673	Pin, Shear
4	3146R	Retainer Spring
5	188845	Assembly, Hub and Plate
6	73610600	Nut, Hex 3/8-24
7	STD551137	Washer, Lock 3/8

KEY NO.	PART NO.	DESCRIPTION
8	74610616	Bolt, Hex 3/8-24 x 1
16	163499	Tine, Spade
17	163500	Tine, Cleaning

NOTE: All component dimensions given in U.S. inches.
1 inch = 25.4 mm

REPAIR PARTS

TILLER - - MODEL NUMBER 944.629672

DECALS

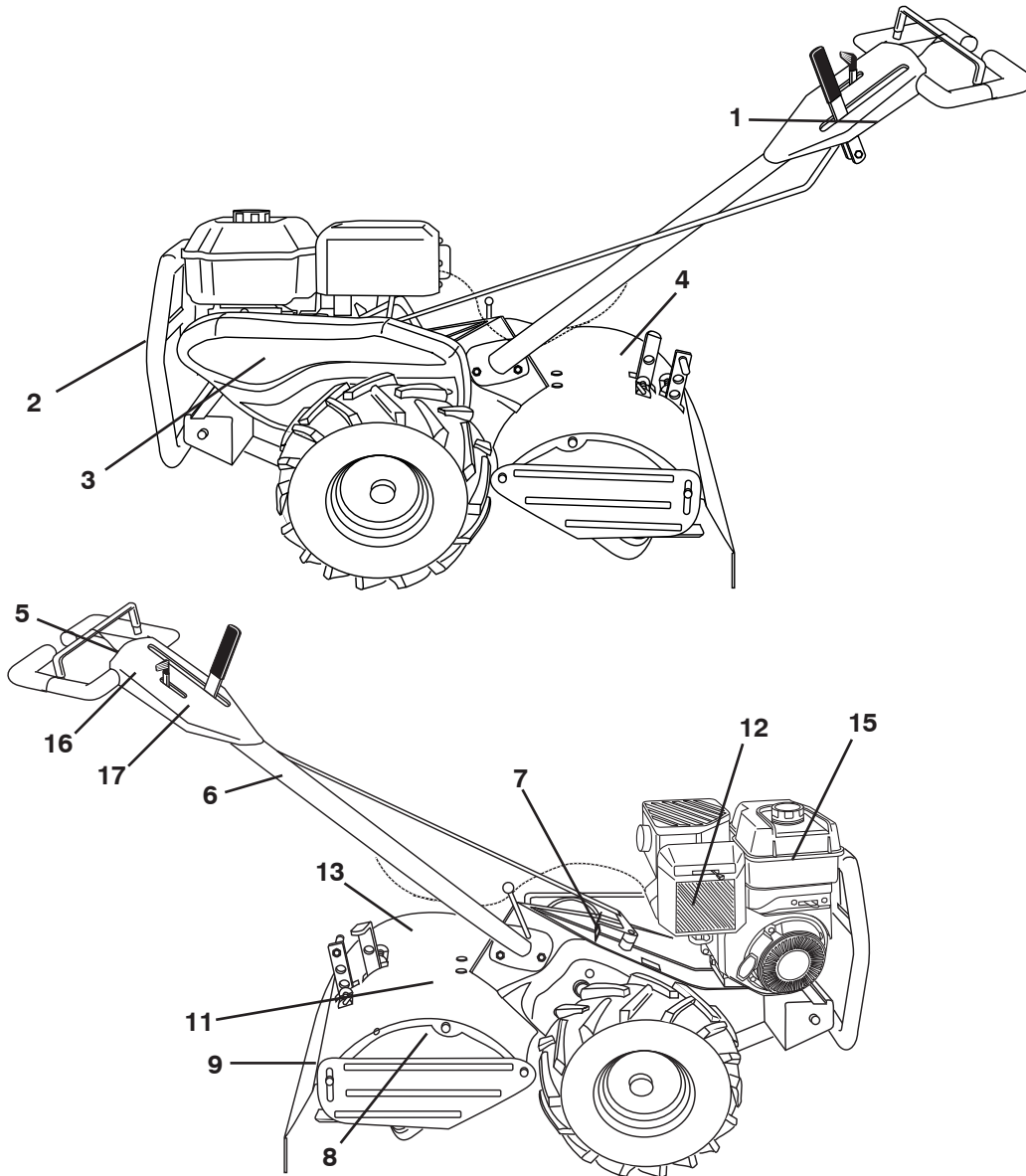

KEY NO.	PART NO.	DESCRIPTION
1	419743	Decal, Ser. Console Control
2	423790	Decal, Logo
3	423786	Decal, BLT GRD
4	418557	Decal, Tine Shield
5	137282	Decal, Caution
6	110614X	Decal, Hand Placement
7	166202	Decal, Shift Indicator
8	166188	Decal, Tine Shield CRT
9	176782	Decal, DRT. WARN
11	419779	Decal, Tine Shield REV
12	435125	Decal, Oper Engine
13	419780	Decal, Tine Shield FWD
15	409143	Decal, Engine
16	423798	Decal, Console
17	419742	Decal, SER. Fast/Slow
--	434934	Manual, Owner's (English)
--	434935	Manual, Owner's (French)

REPAIR PARTS

TILLER - - MODEL NUMBER 944.629672

ENGINE, BRIGGS & STRATTON - - MODEL NUMBER 121002, TYPE NO. 1383-B8

48 SHORT BLOCK

1058 OPERATOR'S MANUAL

1329 REPLACEMENT ENGINE

1330 REPAIR MANUAL

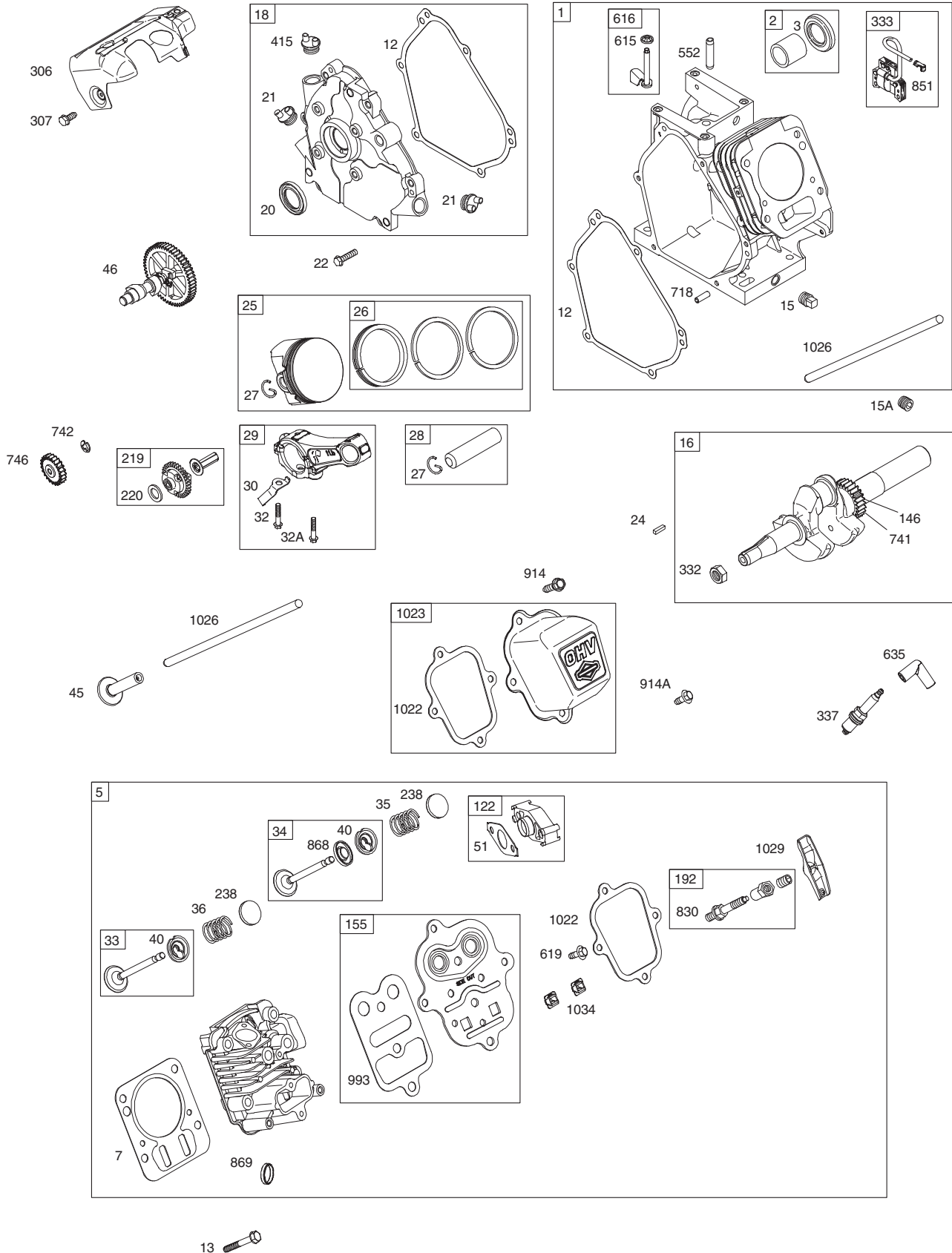

REPAIR PARTS

TILLER - - MODEL NUMBER 944.629672

ENGINE, BRIGGS & STRATTON - - MODEL NUMBER 121002, TYPE NO. 1383-B8

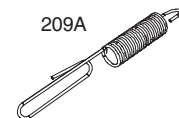
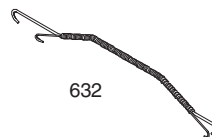
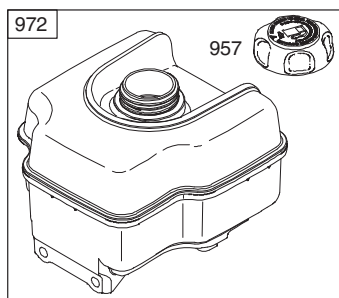
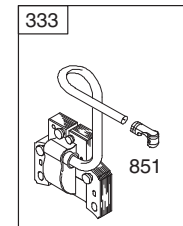
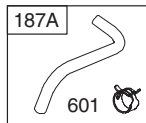
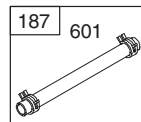
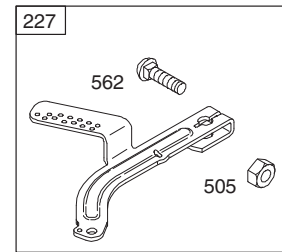
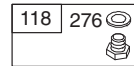
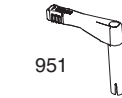
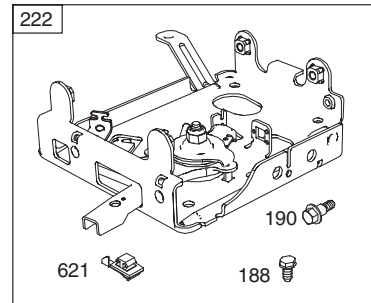
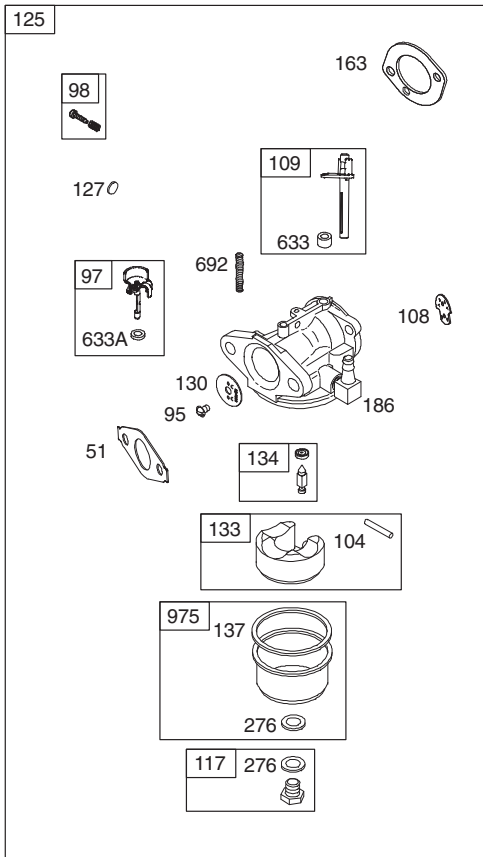
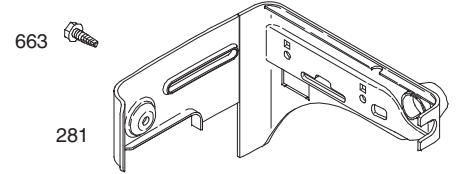
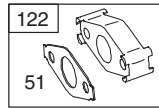

356

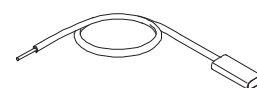

REPAIR PARTS

TILLER - - MODEL NUMBER 944.629672

ENGINE, BRIGGS & STRATTON - - MODEL NUMBER 121002, TYPE NO. 1383-B8

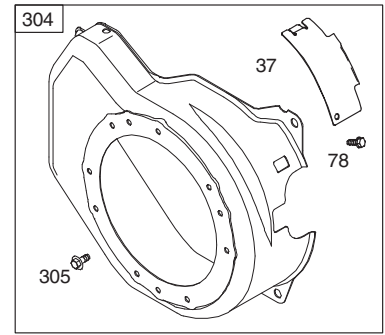
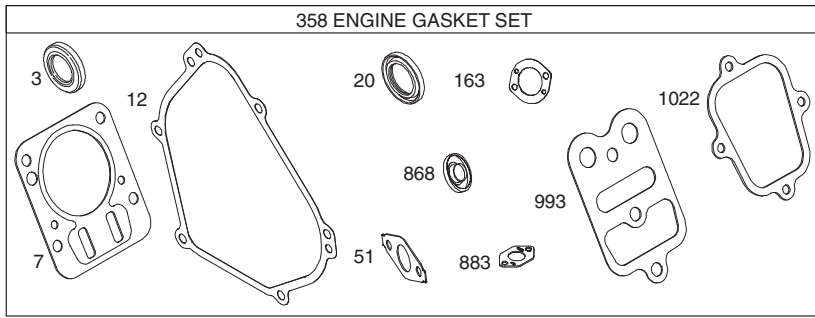

1036 EMISSIONS LABEL

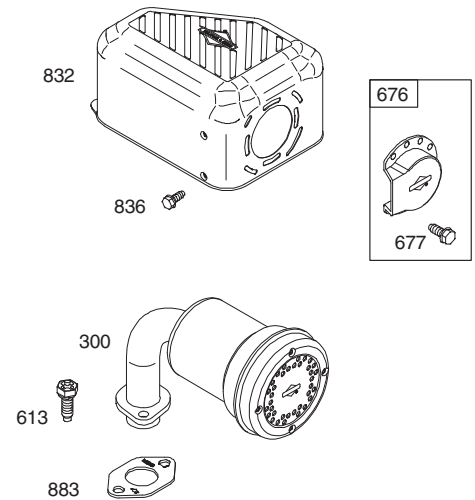
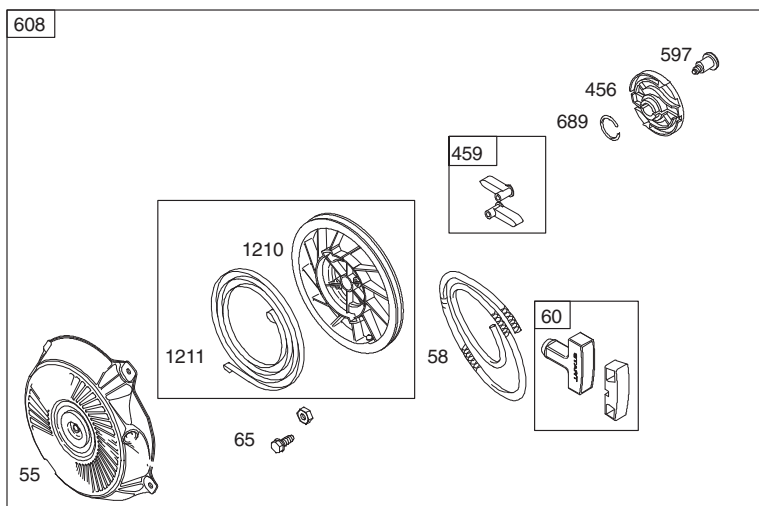
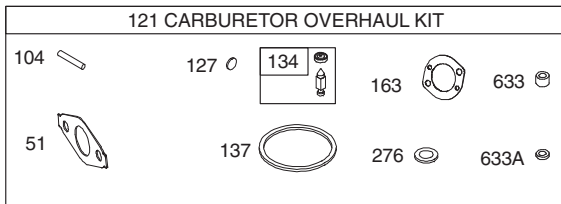
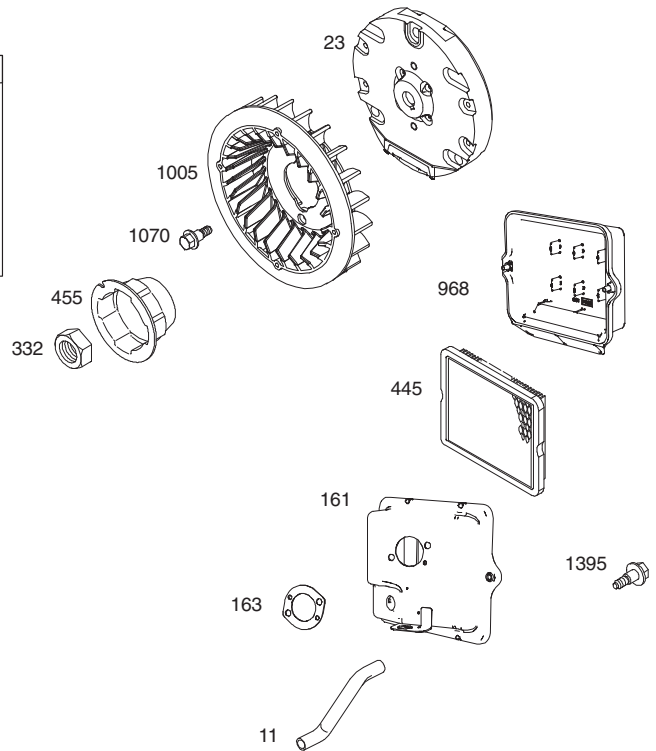
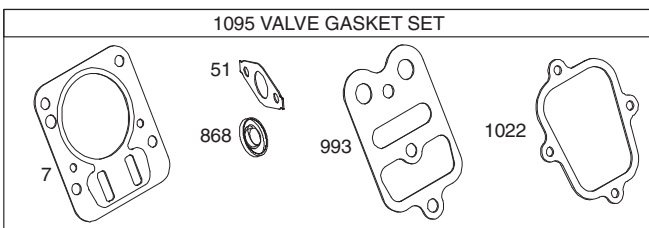

REPAIR PARTS

TILLER - - MODEL NUMBER 944.629672

ENGINE, BRIGGS & STRATTON - - MODEL NUMBER 121002, TYPE NO. 1383-B8

KEY NO.	PART NO.	DESCRIPTION	KEY NO.	PART NO.	DESCRIPTION
1	699510	Cylinder Assembly	161	790631	Base-Air Cleaner
2	399269	Kit-Bushing/Seal (Magneto Side)	163	696024	Gasket-Air Cleaner
3	299819s	Seal-Oil (Magneto Side)	186	692317	Hose-Connector
5	797439	Head-Cylinder	187	791766	Line-Fuel (Cut to Required Length)
7	698210	Gasket-Cylinder Head	187A	791867	Line-Fuel (Formed)
11	790632	Tube-Breather	188	699479	Screw (Control Bracket)
12	699485	Gasket-Crankcase	190	699220	Screw (Fuel Tank)
13	699482	Screw (Cylinder Head)	192	797440	Adjuster-Rocker Arm
15	691686	Plug-Oil Drain	209	691278	Spring-Governor (Platinum)
15A	691682	Plug-Oil Drain	209	692571	Spring-Governor (# 5 Hole)
16	797070	Crankshaft	219	693578	Gear-Governor
18	699696	Cover-Crankcase	220	691724	Washer (Governor Gear)
20	692550	Seal-Oil (PTO Side)	222	793107	Bracket-Control
21	281658s	Cap-Oil Fill	227	794367	Lever-Governor Control
22	699478	Screw (Crankcase Cover/Sump)	238	691300	Cap-Valve
23	699488	Flywheel	265	691024	Clamp-Casing
24	222698s	Key-Flywheel	267	699492	Screw (Casing Clamp)
25	795429	Piston Assembly (Standard)	276	271716	Washer-Sealing
	795430	Piston Assembly (.020" Oversize)	281	793122	Panel-Control
26	791969	Ring Set (Standard)	300	693593	Muffler
	793001	Ring Set (.020" Oversize)	304	699598	Housing-Blower
27	691866	Lock-Piston Pin	305	699480	Screw (Blower Housing)
28	499423	Pin-Piston	306	795334	Shield-Cylinder
29	690124	Rod-Connecting	307	699483	Screw (Cylinder Shield)
30	791584	Dipper-Connecting Rod	332	792723	Nut (Flywheel)
32	691664	Screw (Connecting Rod) (Short)	333	796964	Armature-Magneto
32A	695759	Screw (Connecting Rod) (Long)	334	699477	Screw (Magneto Armature)
33	499642	Valve-Exhaust	337	491055s	Plug-Spark
34	795443	Valve-Intake	356	692390	Wire-Stop
35	691304	Spring-Valve (Intake)	358	791797	Gasket Set-Engine
36	691304	Spring-Valve (Exhaust)	365	699484	Screw (Carburetor)
37	699661	Guard-Flywheel	415	693463	Plug (Crankcase Cover)
40	692194	Retainer-Valve	445	491588s	Filter-Air Cleaner Cartridge
45	690977	Tappet-Valve	455	692591	Cup-Flywheel
46	693404	Camshaft	456	692299	Plate-Pawl Friction
48	791518	Short Block	459	281505s	Pawl-Ratchet
51	692555	Gasket-Intake	505	691251	Nut (Governor Control Lever)
55	791848	Housing-Rewind Starter	552	692346	Bushing-Governor Crank
58	693389	Rope-Starter	562	691119	Bolt (Governor Control Lever)
60	490652	Grip-Starter Rope	597	691696	Screw (Pawl Friction Plate)
65	699228	Screw (Rewind Starter)	601	791850	Clamp-Hose (Green)
95	691636	Screw (Throttle Valve)	608	795930	Starter-Rewind
97	690024	Shaft-Throttle	613	699209	Screw (Muffler)
98	398185	Kit-Idle Speed	615	692576	Retainer-Governor Shaft
104	691242	Pin-Float Hinge	616	692547	Crank-Governor
108	692567	Valve-Choke	619	699230	Screw (Cylinder Head Plate)
109	790624	Shaft-Choke	621	692310	Switch-Stop (Brake)
117	690048	Jet-Main (Standard)	632	693408	Spring/Link-Mechanical Governor
118	497315	Jet-Main (High Altitude)	633	693867	Seal-Choke/Throttle Shaft (Choke Shaft)
121	792006	Kit-Carburetor Overhaul			
122	795643	Spacer-Carburetor	633A	691321	Seal-Choke/Throttle Shaft (Throttle Shaft)
125	698474	Carburetor			
127	691739	Plug-Welch	635	692076	Boot-Spark Plug
130	691181	Valve-Throttle	663	699206	Screw (Control Panel)
133	398187	Float-Carburetor	676	796596	Deflector-Muffler
134	398188	Kit-Needle/Seat	677	699203	Screw (Muffler Deflector)
137	693981	Gasket-Float Bowl	689	691855	Spring-Friction
146	690979	Key-Timing	692	690572	Spring-Detent
155	797442	Plate-Cylinder Head	718	690959	Pin-Locating

REPAIR PARTS

TILLER - - MODEL NUMBER 944.629672

ENGINE, BRIGGS & STRATTON - - MODEL NUMBER 121002, TYPE NO. 1383-B8

KEY NO.	PART NO.	DESCRIPTION
741	695087	Gear-Timing
742	692564	Retainer-E Ring
746	790278	Gear-Idler
830	797441	Stud-Rocker Arm
832	693583	Guard-Muffler
836	699632	Screw (Muffler Guard)
851	493880s	Terminal-Spark Plug
868	795440	Seal-Valve
869	691115	Seat-Valve
883	691893	Gasket-Exhaust
914	699480	Screw (Rocker Cover) (Bottom)
914A	797444	Screw (Rocker Cover)
951	790630	Lever-Choke
957	795027	Cap-Fuel Tank
958	698180	Valve-Fuel Shut Off
968	791082	Cover-Air Cleaner
972	697779	Tank-Fuel
975	790559	Bowl-Fuel
993	694088	Gasket-Cylinder Head Plate
1005	692592	Fan-Flywheel
1022	691890	Gasket-Rocker Cover
1023	499924	Cover-Rocker
1026	790287	Rod-Push
1029	797443	Arm-Rocker
1034	691343	Guide-Push Rod
1036		Label-Emissions (Available from a Briggs & Stratton Authorized Dealer)
1058	277040	Operator's Manual
1070	699201	Screw (Flywheel Fan)
1095	791798	Gasket Set-Valve
1210	791849	Pulley/Spring Assembly (Pulley)
1211	791849	Pulley/Spring Assembly (Spring)
1329	122002-0520-B8	Replacement Engine
1330	276781	Repair Manual
1395	690370	Screw (Air Cleaner Base)

NOTE: All component dimensions given in U.S. inches
1 inch = 25.4 mm

SERVICE NOTES

SERVICE NOTES

GENERAL: Craftsman products are warranted to be free from defects in materials or workmanship for a specific time period as set-out below (the "Warranty Period"). Warranties extend to the original purchaser of a Craftsman product only. Purchases made through an online auction or through any website other than www.sears.ca are excluded. The relevant Warranty Period commences on the original date of purchase. Within this period, SEARS CANADA, Inc. will, at its sole option, repair or replace any products or components which fail in normal use. Such repairs or replacement will be made at no charge to the customer for parts or labor, provided that the customer shall be responsible for any transportation cost.

EXCLUSIONS: This warranty does not cover failures due to normal wear, abuse, misuse, neglect (including but not limited to the use of stale fuel, dirt, abrasives, moisture, rust, corrosion, or any adverse reaction due to improper storage or use habits), improper maintenance or failure to follow maintenance guidelines and/or instructions, failure to operate the product in accordance with the owner's manual or any additional instructions or information provided at the time of purchase or in subsequent communications with the original purchaser, accident or unauthorized alterations or repairs made or attempted by others. Also excluded from warranty coverage - except as provided below - are the following: maintenance, adjustments, components subject to wear including but not limited to: cosmetic components, belts, blades, blade adapters, bulbs, tires, filters, guide bars, lubricants, seats, grips, recoil assy's, saw chains and bars, trimmer lines and spools, spark plugs, starter ropes and tines, and discoloration resulting from ultraviolet light. Any product missing the model and/or serial number identification label will be disqualified from coverage under this warranty.

REPAIRS: Repairs have a 90 day warranty. If the defective product is still within the Warranty Period, then the new warranty is 90 days from the date of repair or to the end of the original Warranty Period, whichever period is longer.

DISCLAIMERS: THE WARRANTIES AND REMEDIES CONTAINED HEREIN ARE EXCLUSIVE AND IN LIEU OF ALL OTHER WARRANTIES, WHETHER ORAL OR WRITTEN (OTHER THAN AS STATED HEREIN), AND WHETHER EXPRESS, IMPLIED OR STATUTORY, INCLUDING BUT NOT LIMITED TO ANY. THIS WARRANTY GIVES YOU SPECIFIC LEGAL RIGHTS, WHICH MAY VARY FROM PROVINCE TO PROVINCE.

IN NO EVENT SHALL SEARS BE LIABLE FOR ANY INCIDENTAL, SPECIAL, INDIRECT OR CONSEQUENTIAL DAMAGES, WHETHER RESULTING FROM THE USE, MISUSE OR INABILITY TO USE THE PRODUCT OR FROM DEFECTS IN THE PRODUCT. THE EXCLUSIONS IN THIS PARAGRAPH SHALL NOT APPLY IN JURISDICTIONS WHERE APPLICABLE LAW DOES NOT ALLOW FOR THE EXCLUSION OF INCIDENTAL OR CONSEQUENTIAL DAMAGES. IN SUCH JURISDICTIONS, THIS PARAGRAPH SHALL NOT APPLY, BUT THE REMAINING PROVISIONS OF THIS DOCUMENT SHALL REMAIN VALID.

SEARS retains the exclusive right to repair or replace the product or offer a full refund of the purchase price at its sole discretion. SUCH REMEDY SHALL BE YOUR SOLE AND EXCLUSIVE REMEDY FOR ANY BREACH OF WARRANTY.

CUSTOMER RESPONSIBILITIES: In addition to complying with all suggested maintenance guidelines and instructions, customers' obligations shall include but shall not be limited to: operating the product in accordance with the owner's manual or any additional instructions or information provided at the time of purchase or in subsequent communications to the purchaser from time to time, exhibit reasonable care in the use, operation, maintenance, general upkeep and storage of the product. Failure to comply with these requirements will void any applicable warranty.

LIST OF APPLICABLE WARRANTY PERIODS: The following list contains the applicable Warranty Period for your Craftsman product and is based on a combination of the type of product or component and the intended and actual use of the product or component:

1. **90 DAYS:** Craftsman products intended for use or actually used for commercial, institutional, professional or income-producing purposes
2. **2 YEARS:** Craftsman riding lawn mowers, yard and garden tractors, walk behind mowers, tillers, brush cutters, snow blowers, handheld blowers, backpack blowers, hedge trimmers and electrical products for noncommercial, nonprofessional, non-institutional, or non-income-producing use, except for those components which are part of engine systems manufactured by third party engine manufacturers for which the purchase has received a separate warranty with product information supplied at the time of purchase.
3. **1 YEAR:** Craftsman power cutters, stump grinders, pole pruners, gas chain saws, electric chain saws, trimmer attachments, baggers and pole saws for noncommercial, nonprofessional, non-institutional, or non-income-producing use.
4. **90 DAYS:** All defective batteries, which will be replaced during this 90-day Warranty Period.
5. **60 DAYS:** Additional Warranty Period of 60 days will apply to adjustments and worn products or components BUT DOES NOT INCLUDE WEAR OR ADJUSTMENTS for products used for commercial, institutional, professional or income-producing purposes. Wear items include but are not limited to: belts, blades, tires, spark plugs, air filters, chains, shear bolts, skid plates, scraper bars, drift cutters, ropes, tines, collection bags and pulleys.

As the Warranty Period runs from the date of purchase and NOT from the date that a product is delivered, opened, assembled or first used, please ensure during this time period that your product or component has been assembled and tested for correction operation regardless of when you intend to actually use it. Claims made after the Warranty Period has expired will not be honored.

PROOF OF PURCHASE/DOCUMENTATION: Warranty coverage is conditioned upon the original purchaser furnishing SEARS CANADA or its authorized third party service provider if applicable, with the original sales receipt or other adequate written proof of the original purchase date and identification of the product. In the event that the original purchaser is unable to provide a company of the original sales receipt, SEARS CANADA Inc. reserves the right to determine in its sole discretion what other written proof of the original purchase date and identification of the product is acceptable.

Get it fixed, at your home or ours!

Just Call:

1-800-4-MY-HOME[®]

(1-800-469-4663)

24 hours a day, 7 days a week

For the repair of major brand appliances **in your own home...**
no matter who made it, no matter who sold it!

For your nearest **Sears Parts and Service** location,
to bring in products like vacuums, lawn equipment and electronics.

For **Sears Parts & Service**, to order the replacement parts,
accessories and owner's manuals that you need to do-it-yourself.

www.sears.ca

To purchase or inquire about a Sears Maintenance Agreement, call:

1-800-361-6665

9 a.m. – 11 p.m. Mon. – Fri., EST, 9 a.m. – 4 p.m. Sat.

Pour service en français:

1-800-LE-FOYER^{MC}

(1-800-533-6937)

www.sears.ca



® / TM Trademarks of Sears, Roebuck and Co. used under license by Sears Canada

^{MD} Marque déposée / ^{MC} Marque de commerce de Sears, Roebuck and Co. utilisée en vertu d'une licence de Sears Canada