

Repair Parts Manual
Manual De Repuestos
GT52XLSi / 96043017801

Please read the operator's manual carefully and make sure you understand the instructions before using the machine.

Por favor lea cuidadosamente y comprenda estas instrucciones antes de usar esta maquina.



English/Spanish



HOW TO USE THIS MANUAL

This manual is designed to provide the customer with a means to identify the parts on his/her tractor when ordering repair parts. The illustrations may or may not represent the actual assemblies; therefore, it is not recommended to use this manual as a guide to assemble or disassemble the tractor. Some hardware and parts are drawn larger in order to more readily identify them.

Each tractor has its own model number. The model number for your tractor can be found on the fender under the seat.

Support / Help

If you require assistance or have questions concerning the application, operation, maintenance or parts for your product:

- Visit our website: www.husqvarna.com
- Call Us Toll Free: 1-800-487-5951

When ordering parts, always give the following information:

- Product - "TRACTOR"
- MODEL NUMBER - "GT52XLSi" (96043017801)"
- Part Number
- Part Description

TABLE OF CONTENTS

SCHEMATIC	3
ELECTRICAL.....	4-5
CHASSIS	6-7
DRIVE.....	8-9
ENGINE.....	10-11
STEERING	12-13
MOWER DECK.....	14-15
MOWER LIFT.....	16
SEAT	17
DECALS.....	18

COMO UTILIZAR ESTE MANUAL

Este manual está diseñado para brindarle al comprador un medio para identificar las piezas del tractor para cuando necesite hacer el pedido de un repuesto. Las ilustraciones pueden o no representar los ensambles reales; por lo tanto, no se recomienda utilizar este manual como una guía para ensamblar o desarmar el tractor. Algunos accesorios y piezas están dibujados en tamaños más grandes para identificarlos con mayor facilidad.

Cada tractor tiene su propio número de modelo. El número de modelo del tractor se encuentra en el guardabarros debajo del asiento.

Soporte / Ayuda

Si necesita asistencia o tiene alguna pregunta acerca de la aplicación, operación, mantenimiento o piezas de su producto:

- Visite nuestro sitio web: www.husqvarna.com
- Llámenos de manera gratuita al: 1-800-487-5951

Cuando haga el pedido de una pieza, siempre brinde la siguiente información:

- Producto: "TRACTOR"
- NÚMERO DE MODELO: "GT52XLSi" (96043017801)"
- Número de pieza
- Descripción de la pieza

ÍNDICE

DIAGRAMA.....	19
DIAGRAMA ELÉCTRICO.....	20-21
CHASIS	22-23
TRANSMISIÓN	24-25
MOTOR	26-27
DIRECCIÓN	28-29
PLATAFORMA DE LA CORTADORA DE CÉSPED.....	30-31
ELEVACIÓN DE LA CORTADORA DE CÉSPED.....	32
ASIENTO.....	33
CALCOMANÍAS.....	34

TRACTOR - MODEL NO. GT52XLSi (96043017801), PRODUCT NO. 960 43 01-78 SCHEMATIC

SCH29

SMART IGNITION SWITCH (S.I.S.)



-DO NOT OPEN!
-PERMANENT DAMAGE CAN RESULT
IF PROPER DIAGNOSTIC PROCEDURES
ARE NOT FOLLOWED.
-CONTACT YOUR DEALER OR AUTHORIZED
SERVICE CENTER FOR REPAIR.



SENSITIVE ELECTRONIC
COMPONENTS INSIDE!

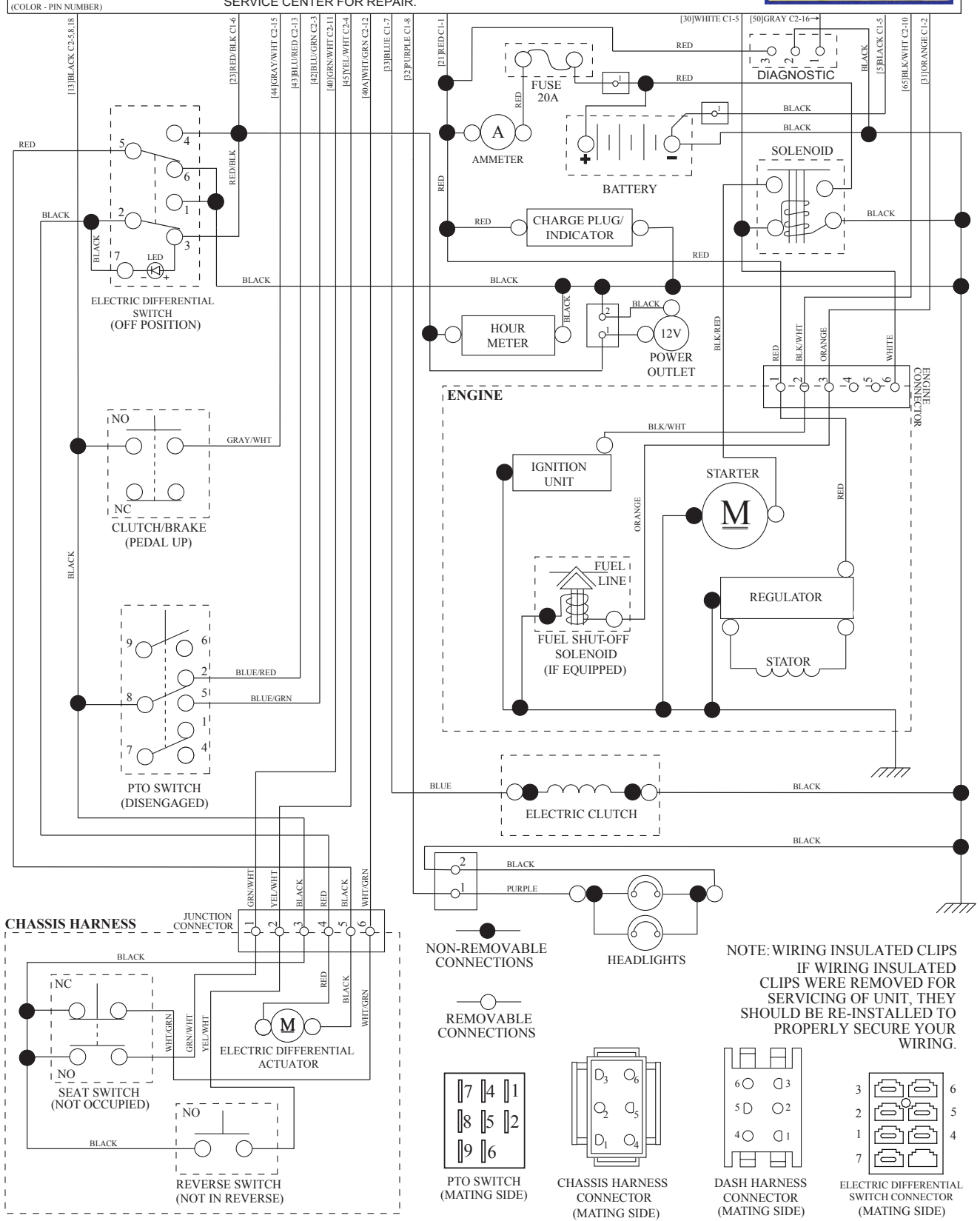

**TRACTOR - MODEL NO. GT52XLSi (96043017801), PRODUCT NO. 960 43 01-78
ELECTRICAL**

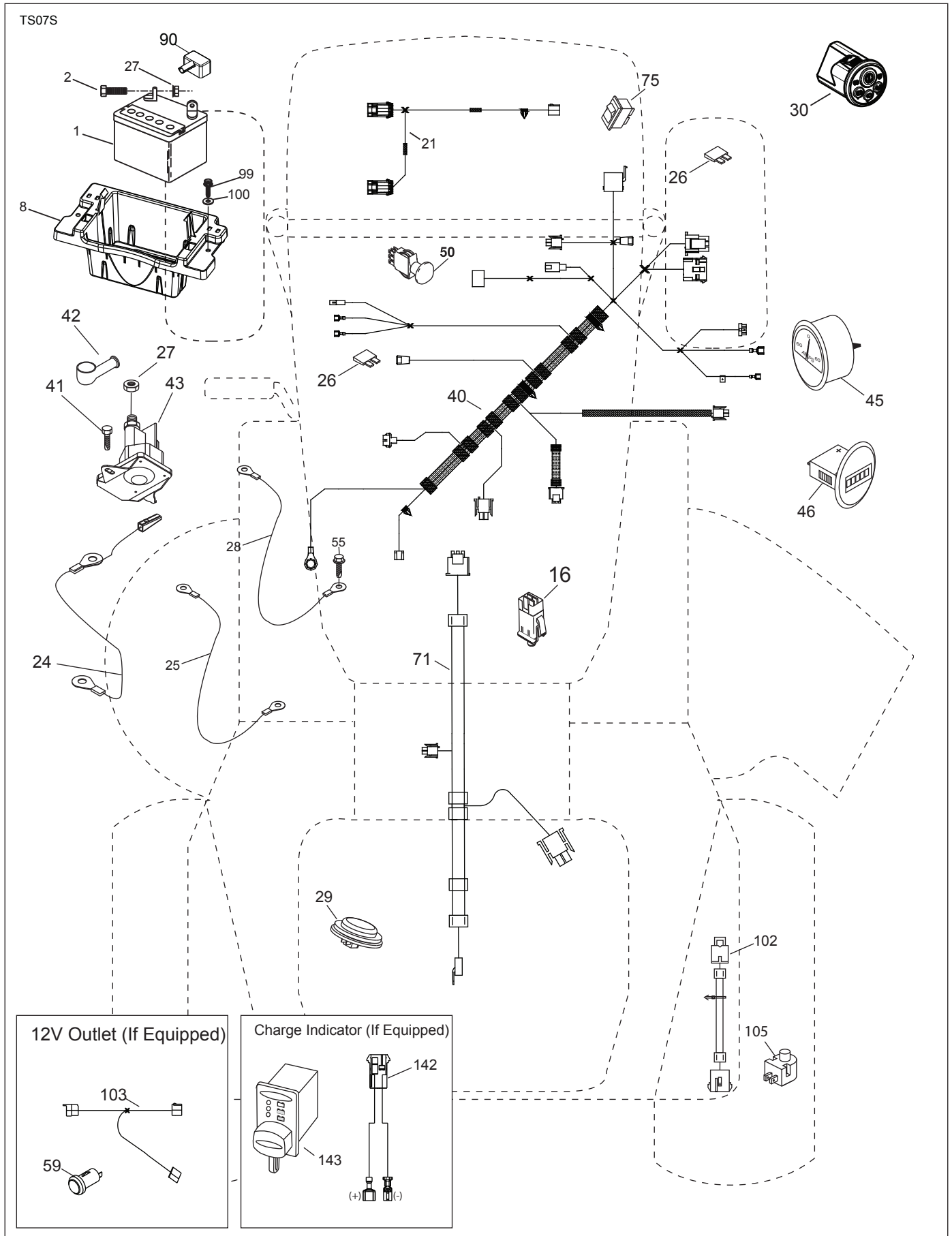

**TRACTOR - MODEL NO. GT52XLSi (96043017801), PRODUCT NO. 960 43 01-78
ELECTRICAL**

KEY NO.	PART NO.	DESCRIPTION
1	532 16 34-65	Battery
2	874 76 04-12	Bolt Hex Hd 1/4-20 unc x 3/4
8	587 20 51-01	Battery Box
16	532 17 61-38	Switch Interlock
21	585 43 64-01	Harness Socket Light
24	585 73 43-01	Cable Battery
25	585 55 55-01	Cable Starter
26	532 17 51-58	Fuse
27	873 51 04-00	Nut Keps Hex 1/4-20 unc
28	585 30 69-01	Cable Ground
29	581 42 93-02	Switch Seat
30	586 83 67-01	Switch Ign Smart
40	585 21 61-02	Harness Ign. Dash
41	817 72 04-08	Screw 1/4-20 unc x 1/2
42	532 13 15-63	Cover Terminal Red
43	582 04 28-01	Solenoid
45	587 55 39-03	Ammeter Round
46	587 55 40-03	Gauge Hourmeter
50	582 10 76-01	Switch PTO
55	817 06 05-12	Screw Thdrol 5/16-18 x 3/4
59	532 40 03-03	Outlet 12-Volt
71	585 21 63-01	Harness chassis
75	580 36 64-01	Switch
90	532 43 53-95	Cover Terminal Battery
99	817 67 04-12	Screw Hexwsh Thdrol 1/4-20 x 3/4
100	819 09 14-16	Washer 9/32 x 7/8 x 16 Ga.
102	532 40 44-54	Harness Pigtail
103	585 13 40-01	Harness Pigtail 12V Outlet
105	532 40 75-68	Switch Reverse
142	583 85 78-01	Pigtail Charge Port
143	532 44 80-59	Charge Port

NOTE: All component dimensions given in U.S. inches
1 inch = 25.4 mm

**TRACTOR - MODEL NO. GT52XLSi (96043017801), PRODUCT NO. 960 43 01-78
CHASSIS**

KEY PART NO.	PART NO.	DESCRIPTION	KEY PART NO.	PART NO.	DESCRIPTION
2	580 43 44-01	Drawbar	205	532 43 97-30	Trim Hood Side RH
3	532 44 44-81	Applique Husq.	206	532 43 97-29	Trim Hood Side LH
5	581 67 41-03	Dash	207	585 42 00-01	Bezel RH
14	532 44 11-77	Hood	208	585 42 01-01	Bezel LH
15	585 42 03-01	Lens LH	214	532 19 91-45	Clip Retainer
18	532 44 06-53	Grille	217	532 40 91-67	Rod Pivot
19	819 13 13-12	Washer 13/32 x 13/16 x 12 Ga.	221	532 19 89-09	Reflector LH
25	585 42 02-01	Lens RH	228	532 19 51-61	Stud Fastener
36	817 06 05-12	Screw 5/16-18 x 3/4	235	532 40 61-29	Spacer Fender
37	532 44 12-08	Fender	236	873 93 05-00	Nut Center Lock 5/16-18 unc
58	532 19 43-14	Bracket Fender	296	585 42 05-01	LED Light LH
68	817 49 05-08	Screw 5/16-18 x 1/2	297	586 18 29-01	Insert Reflect. LH
125	581 68 48-01	Clip Fuel Line	299	585 42 04-01	LED Light RH
130	532 41 63-58	Screw #10 x 0.750 BOS Thread	306	873 90 06-00	Nut Lock
137	532 40 75-90	Bumper Dash	335	532 44 82-04	Cover RH Lower
146	581 85 79-01	Bolt	336	532 44 53-09	Cover LH Lower
150	532 43 97-74	Duct Heat Hood	350	532 44 51-43	Clip X-mas Tree
151	532 43 66-70	Bracket Pivot Hood	351	532 42 17-34	Pin Clevis .375 x 2.125
152	532 43 98-70	Shield Browning	352	532 44 86-34	Clevis .375 x 2.125
159	817 00 06-12	Screw 3/8-16 x 3/4	353	532 17 80-62	Clip Retainer .0375
161	532 43 99-29	Console Fuel Window	354	532 44 86-19	Support Bellcrank
162	532 14 24-32	Screw Hex Wsh Hi-Lo 1/4 x 1/2	355	532 44 86-36	Bellcrank Pivot Lock Diff
165	532 19 43-30	Bracket Support Tank	356	532 44 86-93	Link Lock Diff
175	532 19 63-04	Crossmember	357	532 44 86-84	Spring Compression
176	532 40 07-76	Screw 10-24 x 5/8 Wshd Qdrx	358	580 36 66-01	Swivel Guide
177	532 19 52-28	Bushing Steering	359	584 39 34-01	Actuator Electric
179	532 16 89-37	Nut Push	360	532 44 86-18	Bracket Actuator
180	532 44 55-59	Chassis	361	817 49 06-10	Screw Hxwsh Thdr 3/8-16 x 5/8
182	532 40 68-59	Dash Lower	362	532 44 86-33	Clevis .375 x 2.42
183	874 52 05-20	Bolt 5/16-18 x 1-1/4	365	532 44 73-68	Nylon Spacer .375 x .4375L
189	817 00 05-12	Screw 5/16-18 x 3/4	375	586 90 82-01	Dash Clip-On Bumper
191	586 18 28-01	Insert Reflect. RH	--	586 29 76-01	Plug Light Switch
194	873 90 05-00	Nut Lock Hex Flange 5/16-18	--	532 43 18-82	Kit Guard Brush
196	532 43 96-74	Console Asm. Deck Lift			
199	532 19 82-59	Plate Deck Lift			
202	532 43 97-28	Vent Side Hood RH			
203	532 43 97-27	Vent Side Hood LH			
204	532 43 57-14	Vent Asm Hood Top			

NOTE: All component dimensions given in U.S. inches
1 inch = 25.4 mm

TRACTOR - MODEL NO. GT52XLSi (96043017801), PRODUCT NO. 960 43 01-78 DRIVE

KEY NO.	PART NO.	DESCRIPTION	KEY NO.	PART NO.	DESCRIPTION
1	---	Transaxle, Tufftorq K66ELD (580402201) (Order parts from transaxle manufacturer.)	166	532 42 91-64	Nut Push .625
2	539 91 27-57	Key .25 x 1.25	167	532 40 52-57	Latch Brake Parking
3	532 00 75-63	Washer Thrust Axle Hardened	170	532 19 43-22	Keeper V-Idler Centerspan
7	586 93 54-02	Hub Asm. Wheel	171	872 11 06-16	Bolt Rd Hd Sq NK 3/8-16 unc x 2
9	532 14 00-80	Bolt Hub Wheel	183	587 58 74-01	Spacer Axle
15	819 13 13-16	Washer 13/32 x 13/16 x 16 Ga.	184	587 65 37-01	Handle Parking Brake
17	532 40 10-72	Spring, Brake	185	872 11 06-22	Bolt Rdhd 3/8-16 unc x 2-3/4 G5
26	532 19 96-79	Spring Return Cruise	186	532 19 43-21	Spacer Retainer
29	532 40 72-45	Rod, Brake	187	819 13 32-10	Washer
33	812 00 00-53	Ring E	188	582 21 70-01	Link Clutch Ground Drive Long
35	583 86 45-01	Rod, Brake, Park	189	532 19 43-17	Bellcrank Ground Drive
42	532 12 48-72	Cover, Foot Pedal	190	532 19 43-18	Keeper Bellcrank Ground Drive
43	874 18 04-12	Screw Mach. CR. 1/4-20 x 3/4	196	817 00 06-16	Screw 3/8-16 x 1
49	872 11 06-14	Bolt	197	585 65 86-01	Bracket Clutch Anti-Rotation
50	532 19 43-27	Pulley Idler Flat	206	532 44 85-96	Bracket Mount Latch Cruise
51	873 90 06-00	Lock Nut 3/8-16	207	587 03 14-01	Latch Control Cruise
52	532 19 43-26	Idler V-Groove	208	532 19 78-69	Gear Sector Control Cruise
56	592 85 53-01	V-Belt, Drive	209	532 19 95-92	Rod Control Cruise
64	532 19 78-65	Shaft Asm. Pedal Brake Control	210	532 19 78-60	Rocker Asm. Pedal Control
69	532 12 38-00	Washer 1-1/32 x 1-5/8 x 16 Ga.	211	532 12 01-83	Bearing Nylon
70	532 43 96-61	Console Asm	213	532 40 31-19	Knob Control Cruise
73	874 49 05-44	Bolt Hex Flghd 5/16-18 Gr. 5	214	532 41 68-63	Pedal Forward
74	532 14 24-32	Screw 1/4 x 1/2	215	586 60 65-02	Pedal Reverse
80	589 33 34-02	Strap Torque	220	532 19 89-08	Reflector RH
92	874 76 05-20	Bolt 5/16-18 x 1/2	221	532 40 31-87	Retainer Spring Clip Handle
99	582 40 47-01	Spring Bypass	222	879 21 20-10	Washer 21/32 x 1-1/4 x 10 Ga.
116	873 90 05-00	Nut Lock Hex Flange 5/16-18	225	532 40 73-11	Keeper Belt
125	817 00 05-12	Screw 5/16-18 x 3/4	226	532 40 71-09	Bracket Mount Torque
153	532 12 47-88	Retainer Spring	282	874 49 05-48	Bolt 5/16-18 x 3.0 G5
159	876 02 04-12	Pin Cotter 1/8 x 3/4	284	532 41 76-93	Nut U-Chnl. 1/4-20
160	532 16 94-84	Retainer Clip	304	532 42 33-03	Hair Pin Soft Zinc .059 x 1.125
161	532 10 57-09	Spring, Return, Clutch	366	580 62 62-01	Bracket Reinforcement
163	532 40 72-46	Rod Pedal Control			

NOTE: All component dimensions given in U.S. inches
1 inch = 25.4 mm

TRACTOR - MODEL NO. GT52XLSi (96043017801), PRODUCT NO. 960 43 01-78
ENGINE

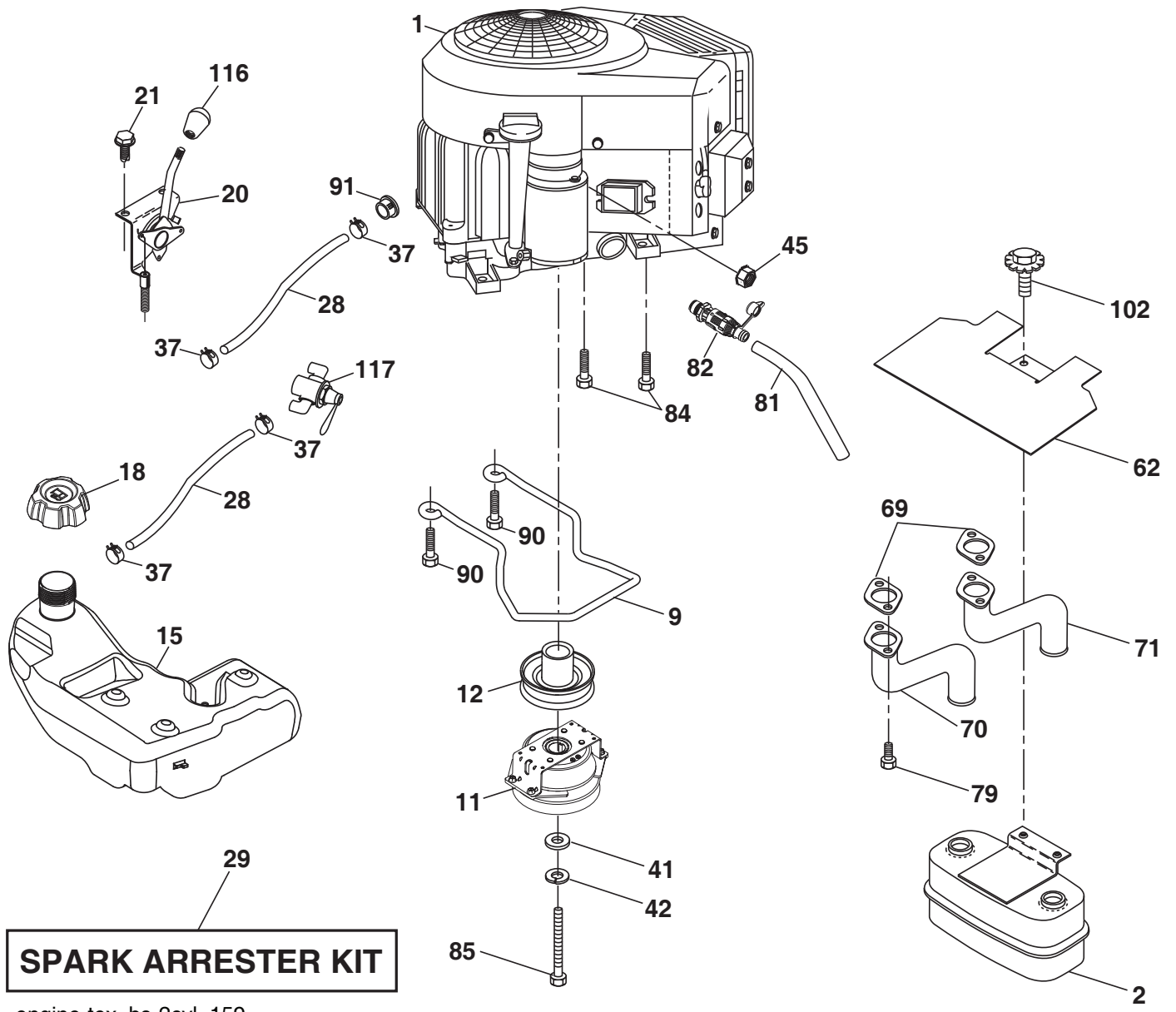

TRACTOR - MODEL NO. GT52XLSi (96043017801), PRODUCT NO. 960 43 01-78 ENGINE

KEY PART NO.	PART NO.	DESCRIPTION
1	-----	Engine B&S Model No. 44N877-0005-G1 (501260101) (Order parts from engine manufacturer.)
2	532 44 59-62	Muffler
9	501 83 26-02	Keeper Belt Engine
11	587 24 14-01	Clutch Electric
12	532 19 43-43	Pulley Engine
15	532 43 80-21	Tank Fuel 4R
18	585 12 48-01	Cap Asm
20	587 24 27-01	Control Throttle
21	532 41 63-58	Screw #10 x 0.750 BOS Thread
28	532 40 11-35	Fuel Line
29	532 13 71-80	Spark Arrester Kit
37	532 12 34-87	Clamp Hose
41	532 12 61-97	Washer 1-1/2 OD x 15/32 ID x .250
42	539 99 02-47	Washer 7/16
45	873 51 04-00	Nut Keps Hex 1/4-20 unc
62	532 43 40-17	Shield Heat Muffler
69	532 16 53-91	Gasket
70	581 88 11-01	Tube Exhaust LH
71	581 88 10-01	Tube Exhaust RH
79	532 18 39-06	Screw Socket HD 5/16-18 x 1
81	532 14 84-56	Tube, Oil Drain
82	532 42 82-87	Valve, Oil Drain
84	817 06 06-20	Screw 3/8-16 x 1-1/4
85	501 60 69-01	Bolt 7/16-20 x 3.0 x Gr. 5
90	817 00 06-16	Screw 3/8-16 x 1
91	532 18 74-95	Bushing
102	817 00 05-12	Screw 5/16-18 x 3/4
116	539 13 26-24	Knob Soft Touch
117	532 42 08-28	Valve Fuel Reserve

NOTE: All component dimensions given in U.S. inches
1 inch = 25.4 mm

For engine service and replacement parts, call the toll free number for your engine manufacturer listed below:

Briggs & Stratton 1-800-233-3723

Engine Power Rating Information

The gross power rating for individual gas engine models is labeled in accordance with SAE (Society of Automotive Engineers) code J1940 (Small Engine Power & Torque Rating Procedure), and rating performance has been obtained and corrected in accordance with SAE J1995 (Revision 2002-05). Torque values are derived at 3060 RPM; horsepower values are derived at 3600 RPM. Actual gross engine power will be lower and is affected by, among other things, ambient operating conditions and engine-to-engine variability. Given both the wide array of products on which engines are placed and the variety of environmental issues applicable to operating the equipment, the gas engine will not develop the rated gross power when used in a given piece of power equipment (actual "on-site" or net power). This difference is due to a variety of factors including, but not limited to, accessories (air cleaner, exhaust, charging, cooling, carburetor, fuel pump, etc.), application limitations, ambient operating conditions (temperature, humidity, altitude), and engine-to-engine variability. Due to manufacturing and capacity limitations, Briggs & Stratton may substitute an engine of higher rated power for this Series engine.

TRACTOR - MODEL NO. GT52XLSi (96043017801), PRODUCT NO. 960 43 01-78
STEERING ASSEMBLY

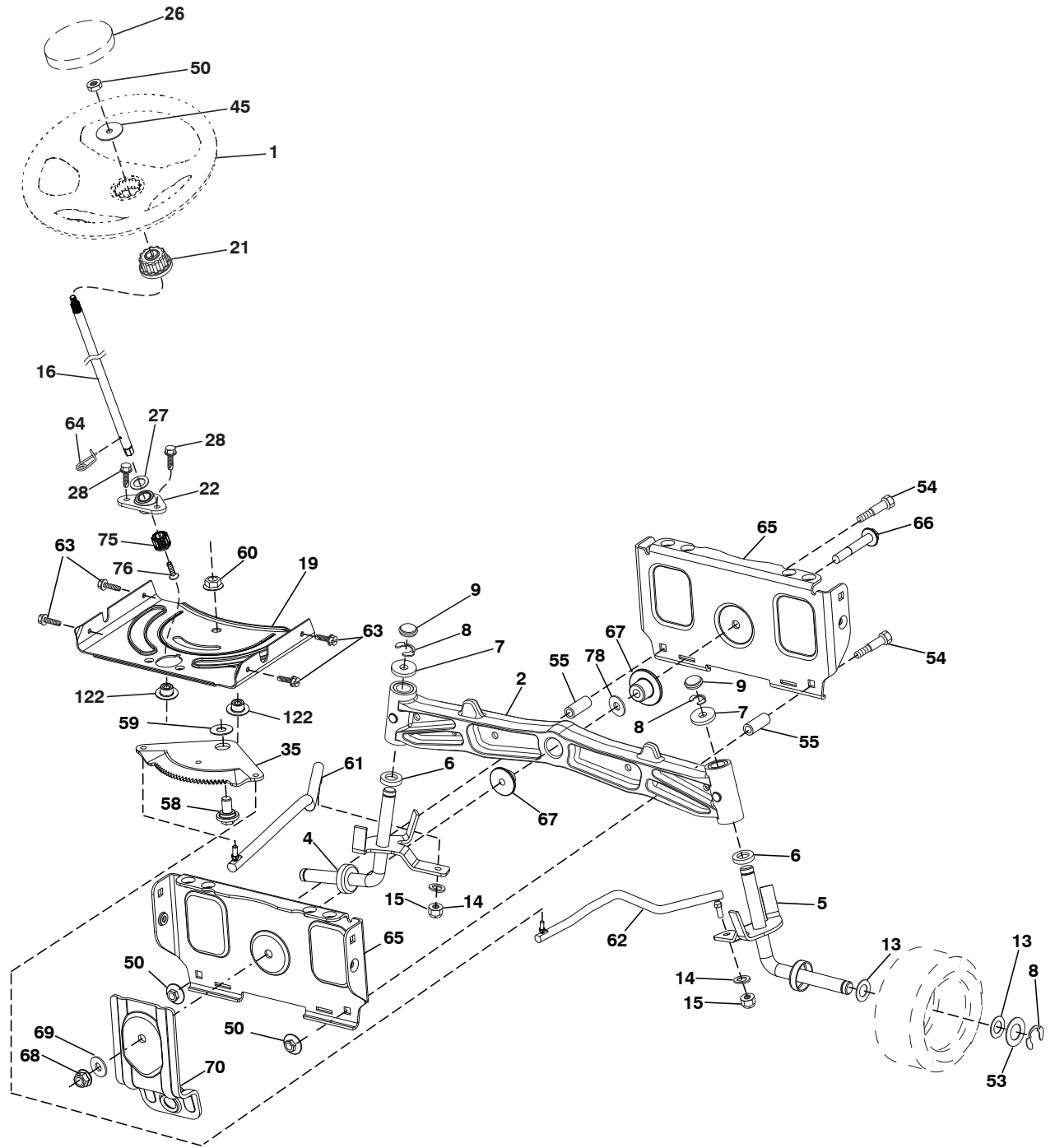

Steering-tex_LEGND2_58

**TRACTOR - MODEL NO. GT52XLSi (96043017801), PRODUCT NO. 960 43 01-78
STEERING ASSEMBLY**

KEY NO.	PART NO.	DESCRIPTION
1	532 43 97-40	Wheel, Steering
2	532 19 59-68	Axle Asm., Front
4	532 40 30-89	Spindle Asm. LH
5	532 40 30-90	Spindle Asm. RH
6	532 12 49-31	Bearing, Race Thrust Harden
7	532 12 17-48	Washer 25/32 x 1-5/8 x 16 Ga.
8	812 00 00-29	Ring, Clip #T5304-75
9	532 12 12-32	Cap, Spindle
13	532 12 17-49	Washer 25/32 x 1-1/4 x 16 Ga.
14	539 99 01-18	Washer, SLW ZD 3/8
15	873 54 06-00	Nut, Crown Lock 3/8-24 unf
16	587 01 60-02	Shaft Steering
19	532 19 47-29	Plate Steering
21	586 84 02-01	Adapter Wheel Steering
22	585 02 98-02	Bearing
26	532 43 97-43	Insert, Wheel Steering
27	819 21 16-16	Washer
28	817 00 06-12	Screw 3/8-16 x 3/4
35	532 19 47-32	Gear, Sector Plate
45	587 01 64-01	Washer 3/8 ID 2-3/8 OD 12 Ga. PLTD
50	873 90 06-00	Nut Lock Flg 3/8-16 unc
53	532 18 89-67	Washer Hardened .793 x 1.637 x .060
54	874 76 06-36	Bolt Hex 3/8-16 unc x 2-1/4
55	532 41 47-36	Spacer
58	532 19 47-47	Bolt Shoulder Sector Pivot CFM
59	532 19 47-48	Washer Thrust Sector Steering
60	873 97 10-00	Nut Flange Lock 5/8-11
61	532 19 47-40	Draglink, LH
62	532 19 47-41	Draglink, RH
63	817 00 05-12	Screw 5/16-18 x 3/4
64	532 19 98-49	Retainer Clip Spring Steering
65	532 19 47-34	Brace Axle Front
66	871 02 07-48	Bolt Hex Fghd 7/16-14 x 3 Serr
67	532 19 47-37	Bushing PM Front Axle
68	873 90 07-00	Nut Lock Flange 7/16-14 Gr. 5
69	532 19 91-62	Washer 1.5 x .505 x .118
70	585 33 88-01	Bracket Deck Susp. Front
75	580 68 37-01	Pinion
76	580 68 36-01	Screw Head Sock
78	532 05 70-79	Washer Thrust
122	532 44 49-62	Cap Gear Sector

NOTE: All component dimensions given in U.S. inches
1 inch = 25.4 mm

**TRACTOR - MODEL NO. GT52XLSi (96043017801), PRODUCT NO. 960 43 01-78
MOWER DECK**

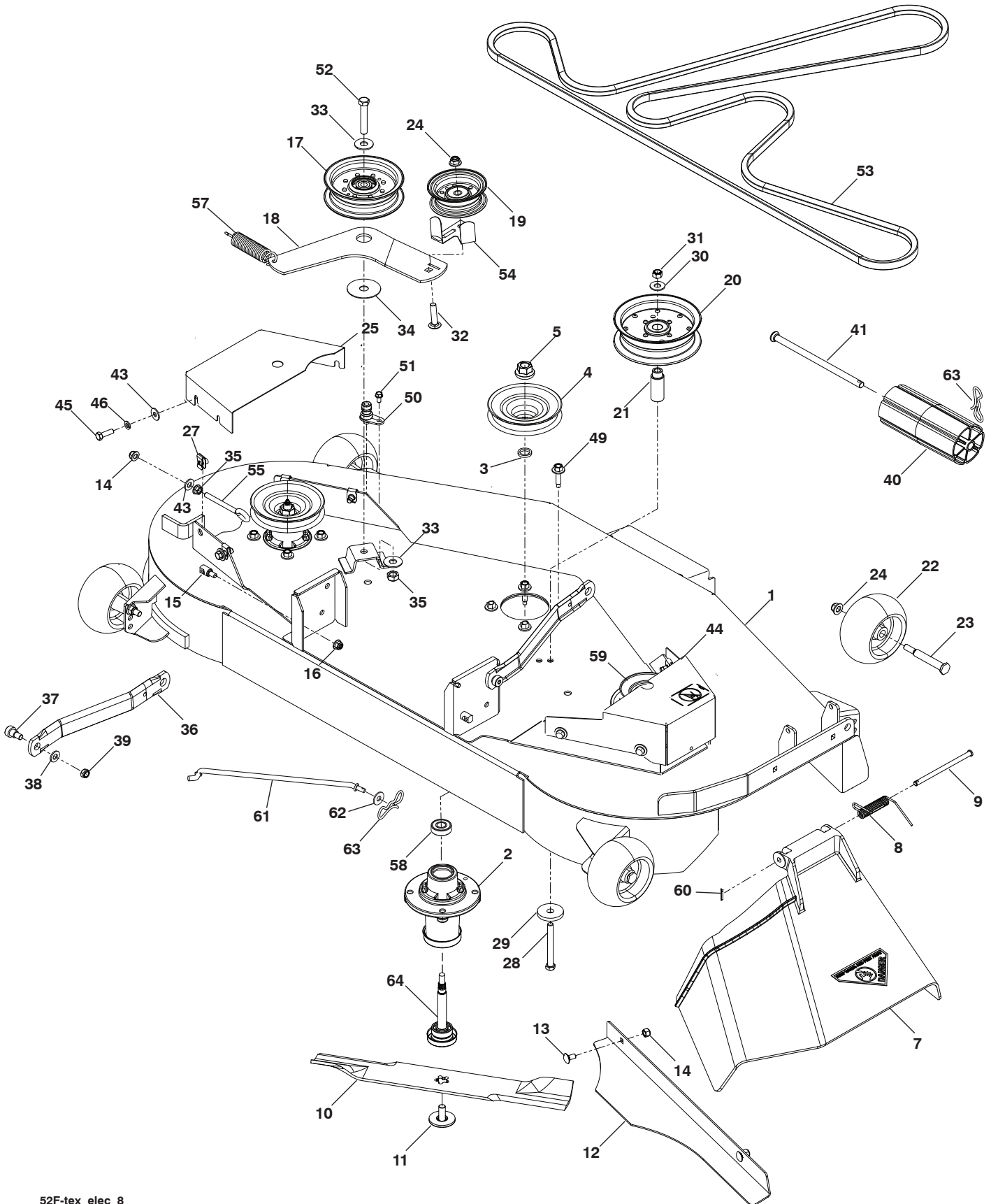

**TRACTOR - MODEL NO. GT52XLSi (96043017801), PRODUCT NO. 960 43 01-78
MOWER DECK**

KEY NO.	PART NO.	DESCRIPTION	KEY NO.	PART NO.	DESCRIPTION
1	574 80 44-02	Deck 52"	36	532 19 51-85	Arm, Susp., Rear
2	539 13 18-98	Housing Assembly	37	539 11 36-21	Sb 3/8-16 x 3/8 Skt Hd
3	539 18 76-90	Washer-Spacer	38	819 13 13-16	Washer, 13/32 x 13/16 x 16 Ga.
4	532 17 43-75	Pulley, Mandrel	39	539 20 02-82	Nut, 3/8-16 Hex Jam Nyloc
5	539 40 02-34	Nut, 9/16 Top Center Lock	40	532 17 60-66	Roller Nose
7	539 11 07-33	Discharge Chute, 52"	41	532 17 91-27	Rod Roller Nose
8	539 11 07-35	Spring - Torsion	43	819 12 14-14	Washer 3/8 x 7/8 14 Ga.
9	539 11 07-36	Pin, Clevis 5/16 x 5.19	44	575 96 73-02	Shield, Belt RH
10	574 87 08-01	Blade, 16-1/4"	45	874 78 05-16	Bolt 5/16-18 x 1
11	532 19 30-03	Bolt, 7/16, Assy Blade	46	539 99 01-87	Washer 5/16 Slw
12	574 87 50-02	Confinement Plate	49	584 95 39-01	Bolt Hex Wsh Rhd 313-18 x 1.19
13	872 11 05-05	Bolt Carr 5/16-18 x 5/8 Short	50	532 41 55-98	Washout Port
14	873 80 05-00	Nut 5/16-18 Hex Nyloc	51	817 49 04-08	Bolt, 1/4-20 x 1/2
15	532 19 51-61	Stud, Fasten w/ Anti- Rotate	52	874 78 07-40	Hcs 7/16-14 x 2-1/2 Gr 5
16	873 90 06-00	Nut Lock Flange 7/16-14 Gr. 5	53	574 84 56-03	Belt, Deck
17	532 19 61-04	Pulley, Idler Spec. Hub	54	532 14 10-43	Guard, Belt
18	574 84 18-02	Arm, Idler, Blk	55	539 11 55-74	Eyebolt 5/16 x 3-1/2
19	532 17 79-68	Pulley, Idler	57	539 10 68-50	Spring
20	539 13 27-28	Pulley, Idler	58	532 11 04-85	Ball Bearing
21	575 22 45-01	Idler Bushing	59	575 35 29-01	Pulley
22	532 13 39-57	Wheel, Gauge	60	532 16 94-84	Clip Retainer
23	532 19 34-06	Bolt, Shoulder	61	532 40 03-37	Rod Anti-Sway
24	521 99 65-01	Nut 3/8-16 Hex Flg Nyloc	62	819 13 13-12	Washer 13/32 x 13/16 x 12 Ga.
25	575 22 47-02	Shield, Belt LH	63	532 19 42-08	Pin Cotter 5/16 Bow Tie Lock
27	539 10 47-63	Retainer 5/16c U Type	64	532 18 72-91	Shaft Asm Mandrel
28	539 10 82-71	Hcs 3/8-16 x 3-1/2 Gr 5	--	532 41 64-05	Coupling Quick Connect
29	539 10 65-04	Heavy Washer	--	501 69 86-01	Mower Deck Complete
30	819 14 16-14	Washer, 3/8 Flat Std			
31	539 97 69-79	Nut 3/8-16 Hex Nyloc			
32	539 99 09-23	Rhsnb 3/8-16 x 1-3/4 Gr 5			
33	539 10 48-64	Washer, 7/16 Flat			
34	532 17 85-15	Washer, Flat Hardened			
35	873 90 07-00	Nut, 7/16-14 Gr. 5			

NOTE: All component dimensions given in U.S. inches
1 inch = 25.4 mm

**TRACTOR - MODEL NO. GT52XLSi (96043017801), PRODUCT NO. 960 43 01-78
MOWER LIFT**

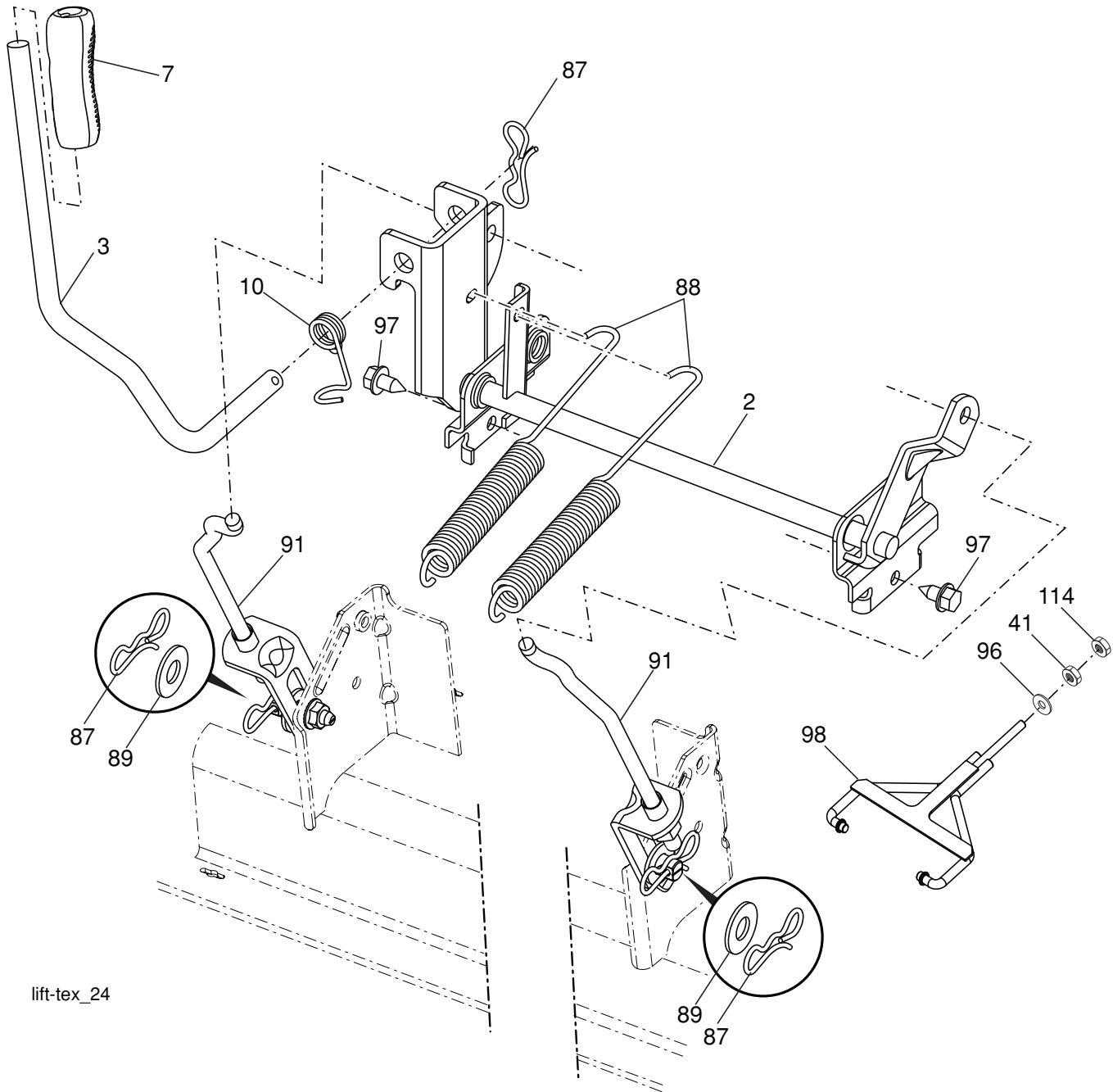

lift-tex_24

KEY NO.	PART NO.	DESCRIPTION
2	532 42 20-27	Shaft Asm., Lift
3	532 19 52-30	Lever Asm., Lift RH
7	580 96 23-01	Grip, Lever
10	532 19 63-14	Spring Torsion
41	532 17 59-94	Nut Lift Link
87	532 19 42-09	Pin Cotter 7/16 Bow Tie Lock
88	532 19 53-04	Spring Lift Assist
89	819 19 19-12	Washer Clear Zinc

KEY NO.	PART NO.	DESCRIPTION
91	532 40 34-07	Link Lift Susp Mower Rear
96	532 19 52-63	Bushing Spherical
97	817 00 06-12	Screw 3/8-16 x .75
98	574 82 25-01	Link Lift Susp. Front Mower
114	873 36 07-00	Nut Jam 7/16-20

NOTE: All component dimensions given in U.S. inches
1 inch = 25.4 mm

**TRACTOR - MODEL NO. GT52XLSi (96043017801), PRODUCT NO. 960 43 01-78
SEAT ASSEMBLY**

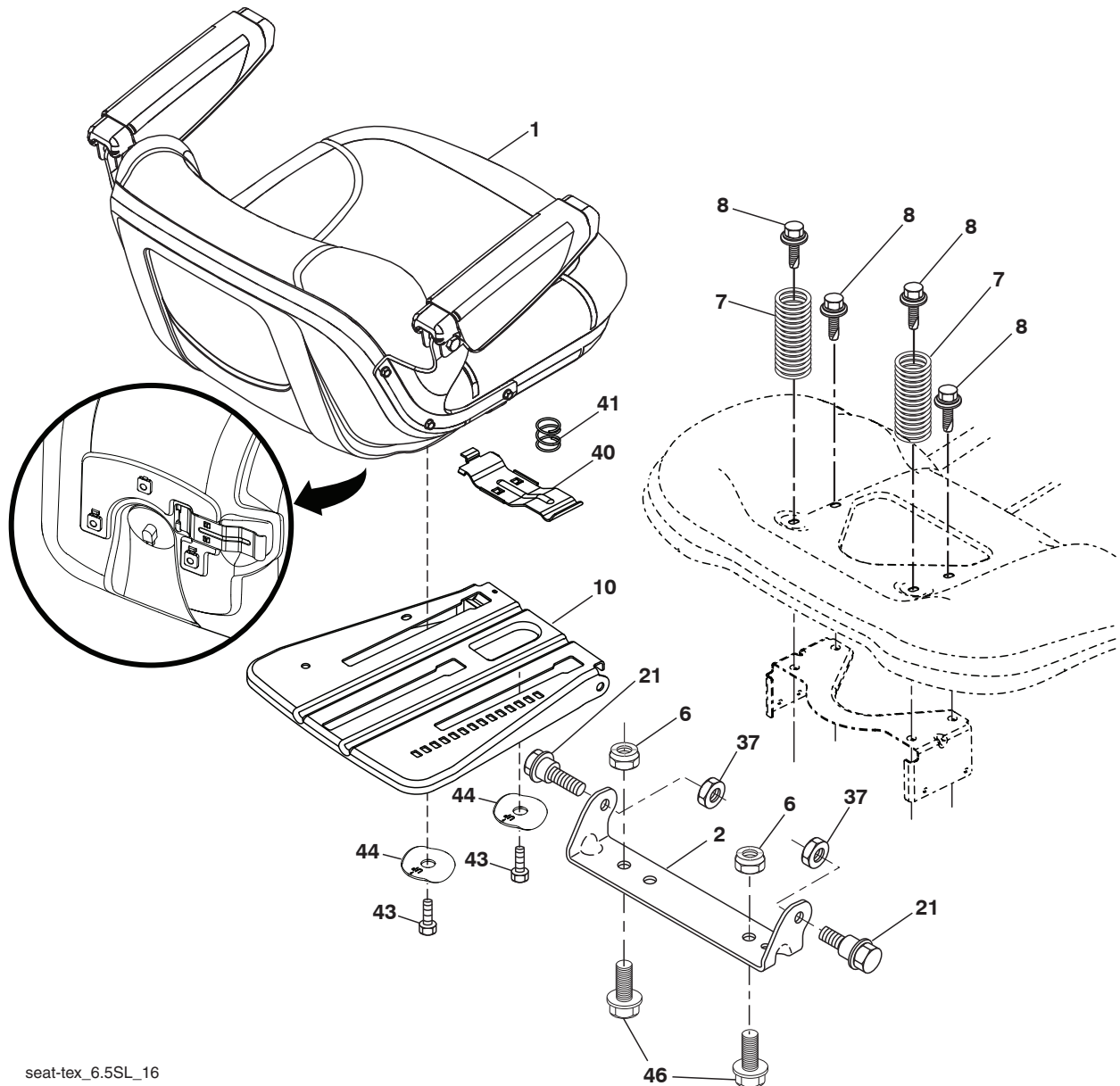

seat-tex_6.5SL_16

KEY NO.	PART NO.	DESCRIPTION
1	588 55 67-01	Seat
2	532 18 01-66	Bracket Pivot Fender
6	873 80 06-00	Nut, Lock w/Ins. 3/8-16 unc
7	589 48 35-01	Spring, Seat Cprsn
8	532 17 18-77	Bolt 5/16-18 unc x 3/4 w/Sems
10	587 23 20-02	Pan, Seat
21	587 90 78-01	Bolt, Shoulder 5/16-18 X 5/8
37	873 80 05-00	Nut, Lock 5/16-18 unc

KEY NO.	PART NO.	DESCRIPTION
40	532 43 98-71	Handle Slide Seat
41	532 19 82-00	Spring Latch Seat
43	874 76 06-12	Bolt Fin Hex 3/8-16 unc x 3/4
44	501 05 18-01	Washer Winged
46	588 09 04-01	Bolt 3/8-16 x 1; 1.25 OD Wshr SEMS

NOTE: All component dimensions given in U.S. inches
1 inch = 25.4 mm

**TRACTOR - MODEL NO. GT52XLSi (96043017801), PRODUCT NO. 960 43 01-78
DECALS**

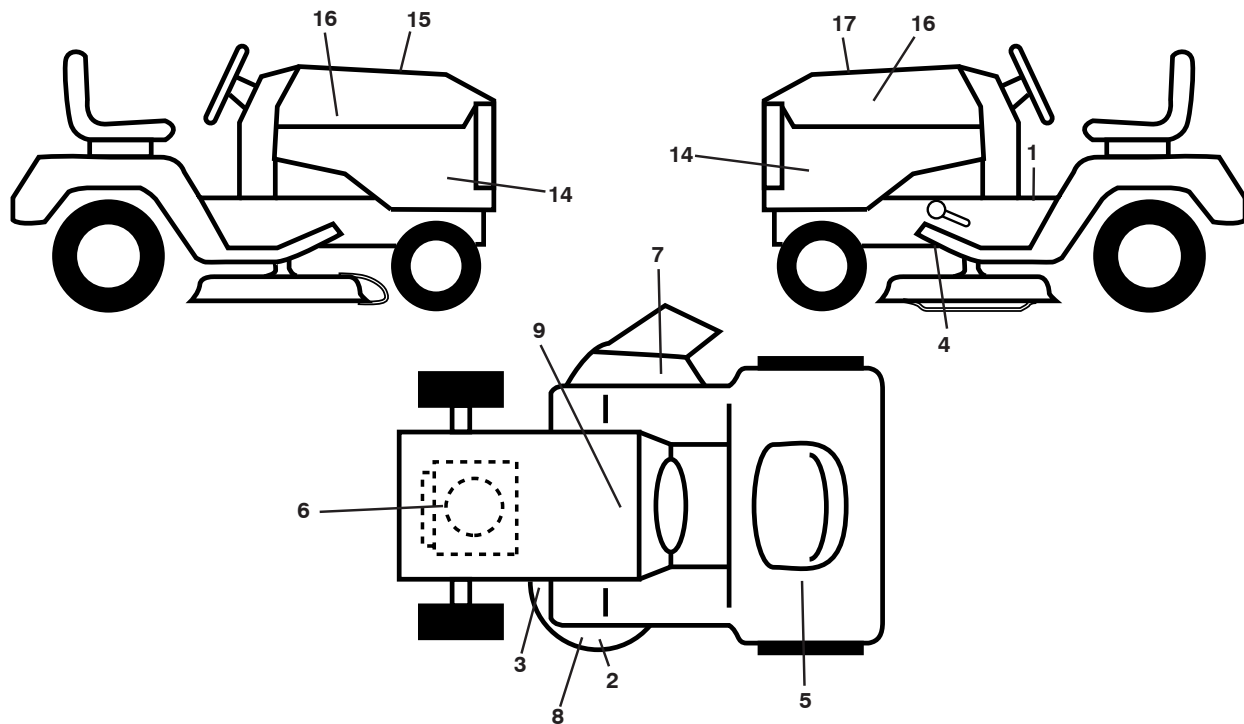

**KEY PART
NO. NO.**

KEY PART NO.	NO.	DESCRIPTION
1	583 83 44-01	Decal, Operator's
2	581 72 43-01	Decal, No Step
3	581 58 00-02	Decal, Mower Schematic
4	532 41 86-00	Decal, FWD Pedal
5	587 01 51-01	Decal, Warning Reserve
6	586 00 07-01	Decal, Eng. H.P.
7	584 90 46-01	Decal, Deflect. Warning
8	532 44 81-21	Decal, HV
9	532 14 50-05	Decal, Battery Dnge/Poi
14	585 68 15-01	Decal, Panel Side
15	532 42 38-29	Decal, Cust. Resp.

**KEY PART
NO. NO.**

KEY PART NO.	NO.	DESCRIPTION
16	581 62 73-01	Decal, Hood Logo
17	586 06 70-01	Decal, Replacement
--	501 74 90-01	Decal, Drawbar Locking Differential
--	581 72 48-01	Decal, Bypass
--	532 43 98-82	Pad, Footrest, LH
--	532 43 98-81	Pad, Footrest, RH
--	115 78 87-26	Manual, Operator's (English/Spanish)
--	115 78 88-27	Manual, Parts (English/Spanish)
--	587 71 00-26	Manual, Quick Start Guide (English/Spanish)

WHEELS AND TIRES

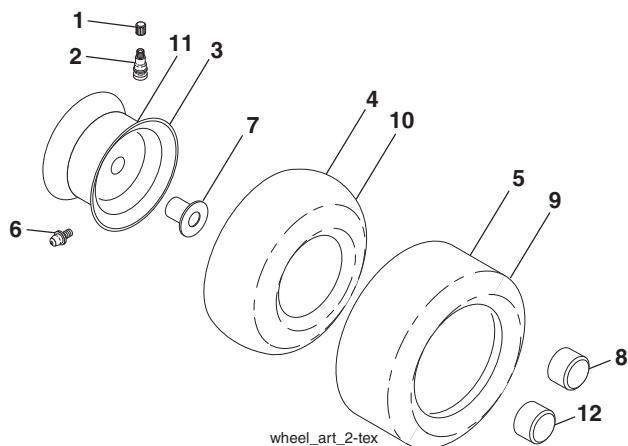

**KEY PART
NO. NO.**

KEY PART NO.	NO.	DESCRIPTION
1	532 05 91-92	Cap, Valve, Tire
2	532 06 51-39	Stem, Valve
3	532 18 18-39	Rim Assembly, Front
4	532 00 81-34	Tube, Front (Service Item Only)
5	532 16 10-24	Tire, Front 16 x 6.5-8
6	532 12 49-57	Fitting, Grease (Front Wheel Only)
7	532 12 49-59	Bearing, Flange (Front Wheel Only)
8	532 17 50-39	Cap, Axle, Front
9	532 17 04-53	Tire, Rear 23 x 10.5-12
10	532 00 71-54	Tube, Rear (Service Item Only)
11	532 14 45-10	Rim Assembly, Rear
12	501 50 31-01	Cap, Hub, GT, PM, Black, Rear
--	532 14 43-34	Sealant, Tire (10 oz. Tube)

NOTE: All component dimensions given in U.S. inches
1 inch = 25.4 mm

TRACTOR - - MODELO NO. GT52XLSi (96043017801), PRODUCT NO. 960 43 01-78

DIAGRAMA

SCH29-s

SMART IGNITION SWITCH (S.I.S.)

NO CONTIENE PARTES REPARABLES POR EL USUARIO

- ¡NO ABRIR!
- PUEDE OCURRIR UN DAÑO PERMANENTE SI NO SE SIGUEN LOS PROCEDIMIENTOS DE DIAGNÓSTICO APROPIADOS.
- CONTACTE A SU DISTRIBUIDOR O CENTRO DE SERVICIO AUTORIZADO PARA LA REPARACIÓN.



¡CONTIENE COMPONENTES ELECTRÓNICOS SENSIBLES!

ADVERTENCIA:
RESPETE LAS PRECAUCIONES PARA EL MANEJO DE DISPOSITIVOS ELECTROESTÁTICOS SENSIBLES

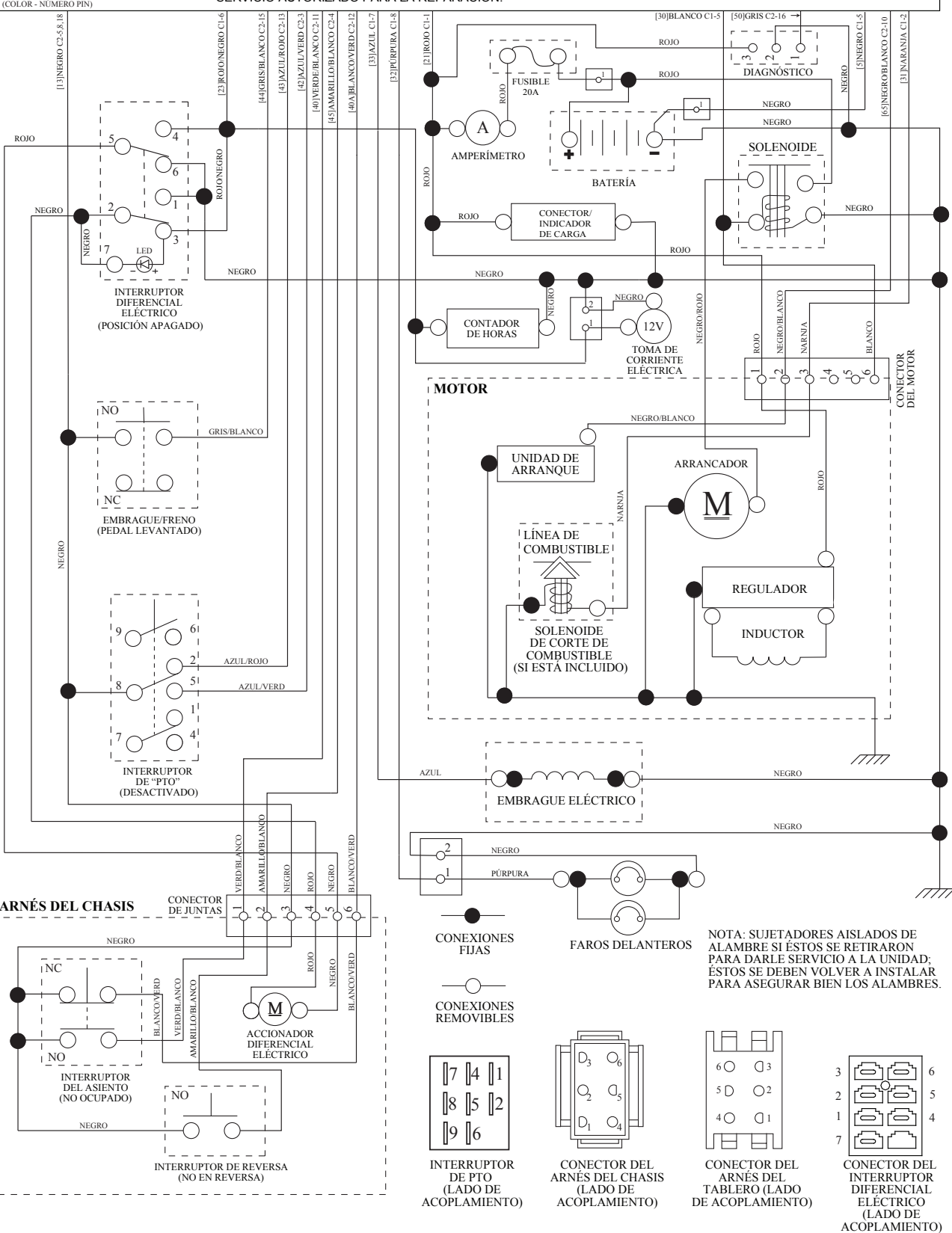

NOTA: SUJETADORES AISLADOS DE ALAMBRE SI ÉSTOS SE RETIRARON PARA DARLE SERVICIO A LA UNIDAD; ÉSTOS SE DEBEN VOLVER A INSTALAR PARA ASEGURAR BIEN LOS ALAMBRES.

TRACTOR - - MODELO NO. GT52XLSi (96043017801), PRODUCT NO. 960 43 01-78
DIAGRAMA ELÉCTRICO

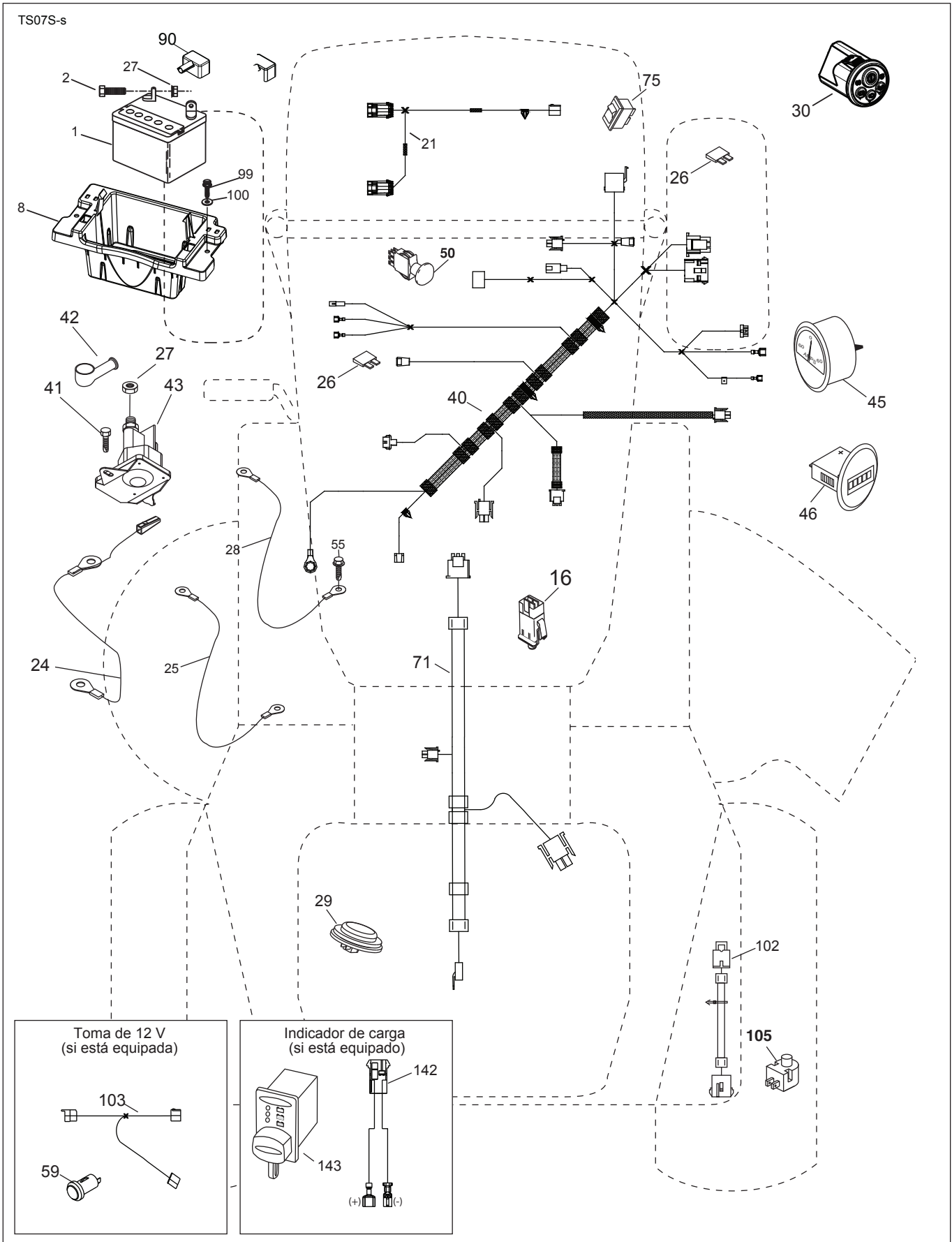

**TRACTOR - - MODELO NO. GT52XLSi (96043017801), PRODUCT NO. 960 43 01-78
DIAGRAMA ELÉCTRICO**

CÓDIGO No.	PIEZA No.	DESCRIPCIÓN
1	532 16 34-65	Batería
2	874 76 04-12	Perno de cabeza hexagonal de 1/4-20 x 3/4
8	587 20 51-01	Caja de la batería
16	532 17 61-38	Interruptor corta corriente a presión
21	585 43 64-01	Cableado del enchufe para la luz
24	585 73 43-01	Cable de Batería
25	585 55 55-01	Cable
26	532 17 51-58	Fusible
27	873 51 04-00	Tuerca 1/4-20 unc
28	585 30 69-01	Cable a tierra
29	581 42 93-02	Interruptor del asiento
30	586 83 67-01	interruptor inteligente
40	585 21 61-02	Cableado del tablero de encendido
41	817 72 04-08	Tornillo 1/4-20 unc x 1/2
42	532 13 15-63	Cubierta de la terminal
43	582 04 28-01	Solenoides
45	587 55 39-03	Indicador amperímetro
46	587 55 40-03	Indicador cronómetro
50	582 10 76-01	Interruptor PTO
55	817 06 05-12	Tornillo 5/16-18 x 3/4
59	532 40 03-03	Salida 12-V
71	585 21 63-01	Cableado de encendido
75	580 36 64-01	Interruptor
90	532 43 53-95	Tapa de los bornes de la batería
99	817 67 04-12	Tornillo 1/4-20 x 3/4
100	819 09 14-16	Arandela 9/32 x 7/8 x calibre 6
102	532 40 44-54	Cableado
103	585 13 40-01	Cableado
105	532 40 75-68	Interruptor
142	583 85 78-01	Cableado
143	532 44 80-59	Conector de carga

NOTA: Las dimensiones de todos los componentes están expresadas en pulgadas americanas. 1 pulgada = 25,4 mm

TRACTOR - - MODELO NO. GT52XLSi (96043017801), PRODUCT NO. 960 43 01-78 CHASIS

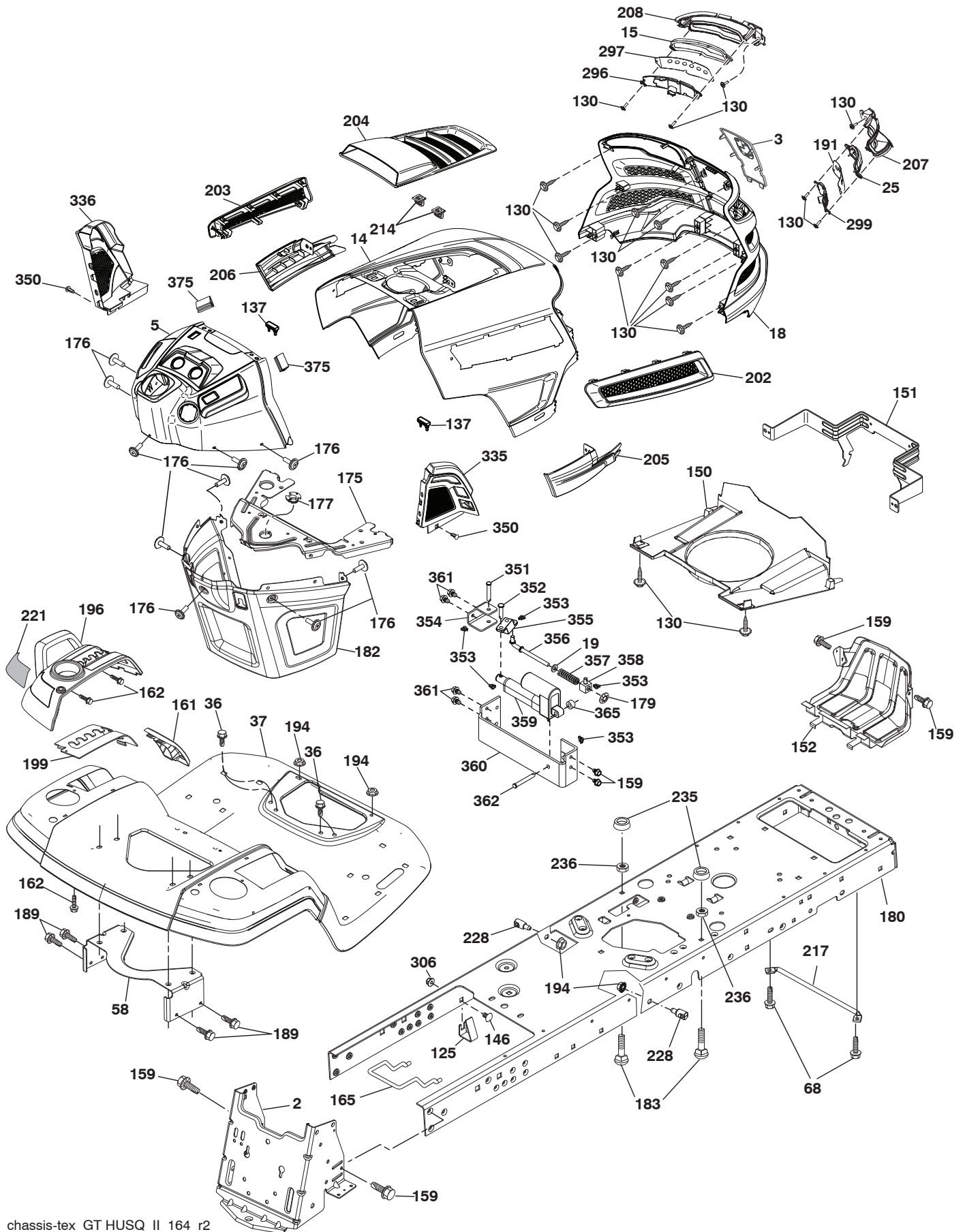

chassis-tex_GT HUSQ_II_164_r2

TRACTOR - - MODELO NO. GT52XLSi (96043017801), PRODUCT NO. 960 43 01-78 CHASIS

CÓDIGO No.	PIEZA No.	DESCRIPCIÓN	CÓDIGO No.	PIEZA No.	DESCRIPCIÓN
2	580 43 44-01	Barra de tracción	206	532 43 97-29	Camisa de Capota (LI)
3	532 44 44-81	Aplica	207	585 42 00-01	Bisel derecho
5	581 67 41-03	Tablero	208	585 42 01-01	Bisel izquierdo
14	532 44 11-77	Capota	214	532 19 91-45	Cierre
15	585 42 03-01	Lente izquierdo de la parrilla	217	532 40 91-67	Varilla giratoria
18	532 44 06-53	Parrilla	221	532 19 89-09	Reflector (LI)
19	819 13 13-12	Arandela de 13/32 x 13/16 x 12 calibre 16	228	532 19 51-61	Sujetador del travesaño
25	585 42 02-01	Lente derecho de la parrilla	235	532 40 61-29	Separador del guardabarros
36	817 06 05-12	Tornillo 5/16-18 x 3/4	236	873 93 05-00	Tuerca 5/16-18 unc
37	532 44 12-08	Guardabarros	296	585 42 05-01	LED faro (LI)
58	532 19 43-14	Soporte	297	586 18 29-01	Parrilla reflector (LI)
68	817 49 05-08	Tornillo 5/16-18 x 1/2	299	585 42 04-01	LED faro (LD)
125	581 68 48-01	Soporte	306	873 90 06-00	Tuerca
130	532 41 63-58	Tornillo #10 x 0.750	335	532 44 82-04	Cubierta (LD)
137	532 40 75-90	Cubierta Tablero	336	532 44 53-09	Cubierta (LI)
146	581 85 79-01	Perno	350	532 44 51-43	Clip del árbol de navidad
150	532 43 97-74	Cubierta térmica del conducto	351	532 42 17-34	Clavija de horquilla .375 x 2.125
151	532 43 66-70	Soporte	352	532 44 86-34	Clavija .375 x 2.125
152	532 43 98-70	Protector contra oscurecimiento	353	532 17 80-62	Pinzas de retención .0375
159	817 00 06-12	Tornillo 3/8-16 x 3/4	354	532 44 86-19	Soporte
161	532 43 99-29	Ventana	355	532 44 86-36	Mecanismo
162	532 14 24-32	Tornillo 1/4 x 1/2	356	532 44 86-93	Acoplamiento
165	532 19 43-30	Soporte	357	532 44 86-84	Resorte
175	532 19 63-04	Travesaño	358	580 36 66-01	Guía
176	532 40 07-76	Tornillo 10-24 x 5/8	359	584 39 34-01	Accionador
177	532 19 52-28	Buje de soporte del guardabarros de carga	360	532 44 86-18	Soporte del accionador
179	532 16 89-37	Tuerca de presión	361	817 49 06-10	Tornillo 3/8-16 x 5/8
180	532 44 55-59	Chasis	362	532 44 86-33	Clavija .375 x 2.42
182	532 40 68-59	Tablero	365	532 44 73-68	Separador .375 x .4375L
183	874 52 05-20	Perno 5/16-18 x 1-1/4	375	586 90 82-01	Cubierta Capota
189	817 00 05-12	Tornillo 5/16-18 x 3/4	--	586 29 76-01	Tapon, Interruptor de luz
191	586 18 28-01	Parrilla reflector (LD)	--	532 43 18-82	Kit del protector del cepillo
194	873 90 05-00	Tuerca 5/16-18			
196	532 43 96-74	Ensamble de la consola de la plataforma de elevación			
199	532 19 82-59	Plataforma de elevación			
202	532 43 97-28	Salida de Ventilación (LD)			
203	532 43 97-27	Salida de Ventilación (LI)			
204	532 43 57-14	Salida de Ventilación superior			
205	532 43 97-30	Camisa de Capota (LD)			

NOTA: Las dimensiones de todos los componentes están expresadas en pulgadas americanas. 1 pulgada = 25,4 mm

TRACTOR - - MODELO NO. GT52XLSi (96043017801), PRODUCT NO. 960 43 01-78
TRANSMISIÓN

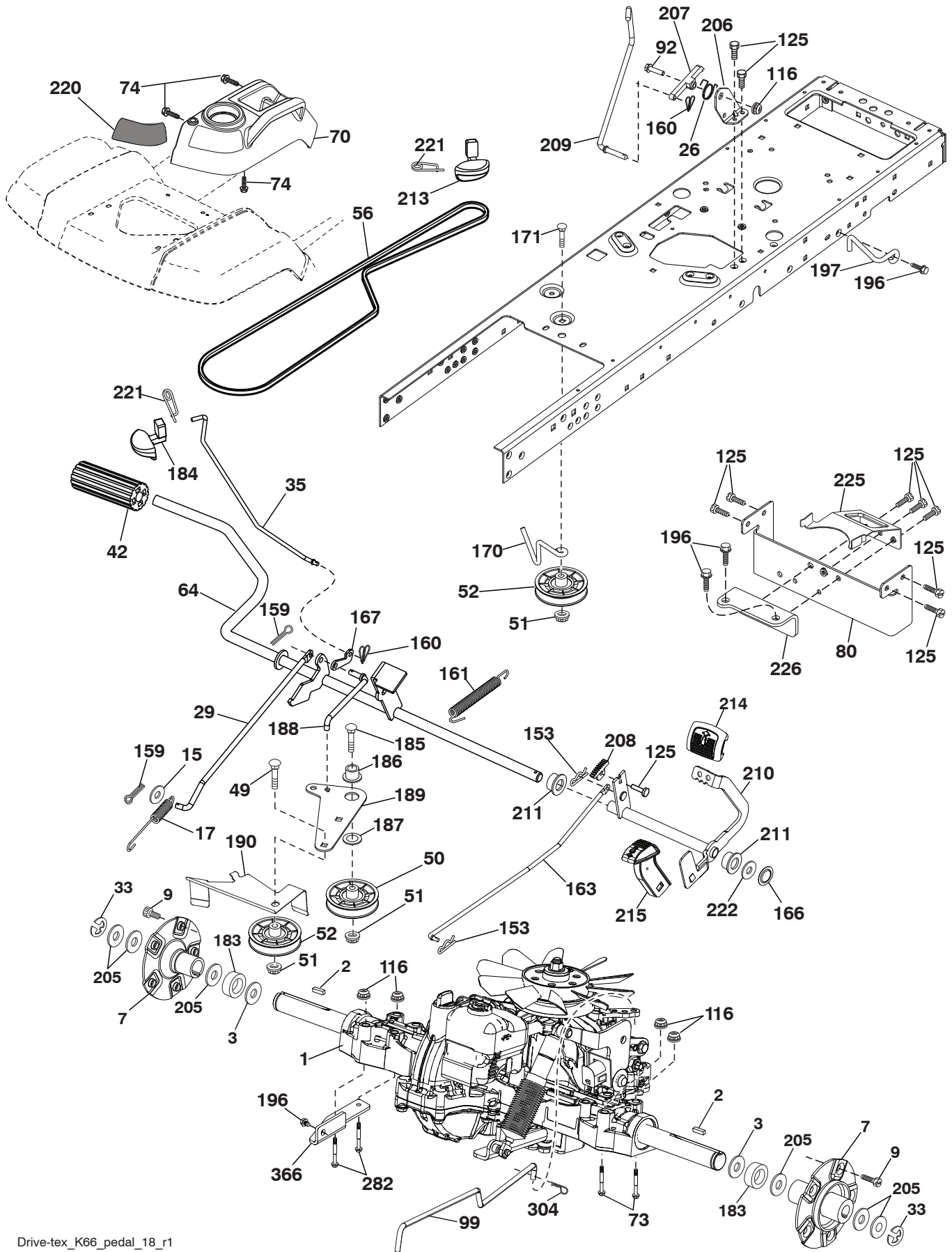

**TRACTOR - - MODELO NO. GT52XLSi (96043017801), PRODUCT NO. 960 43 01-78
TRANSMISIÓN**

CÓDIGO No.	PIEZA No.	DESCRIPCIÓN	CÓDIGO No.	PIEZA No.	DESCRIPCIÓN
1	-----	Transeje, Tufftorq K66ELD (580402201) (Haga el pedido de las piezas al fabricante del transeje.)	184	587 65 37-01	Manija del freno de mano
			185	872 11 06-22	Perno 3/8-16 unc x 2-3/4 Gr 5
			186	532 19 43-21	Espaciador de retención
			187	819 13 32-10	Arandela
			188	582 21 70-01	Mecanismo de desplazamiento de la varilla de mando del embrague
2	539 91 27-57	Cuña .25 x 1.25	189	532 19 43-17	Palanca acodada del mecanismo de desplazamiento
3	532 00 75-63	Arandela	190	532 19 43-18	Sujetador de la palanca acodada del mecanismo de desplazamiento
7	586 93 54-02	Rueda eje la asamblea	196	817 00 06-16	Tornillo 3/8-16 x 1
9	532 14 00-80	Perno	197	585 65 86-01	Bracket Clutch Anti-Rotation
15	819 13 13-16	Arandela 13/32 x 13/16 x Calibre 16	206	532 44 85-96	Soporte
17	532 40 10-72	Resorte de freno	207	587 03 14-01	Bloqueo del control del crucero
26	532 19 96-79	Crucero con retorno de muelle	208	532 19 78-69	Engranaje del sector de control del crucero
29	532 40 72-45	Varilla del freno	209	532 19 95-92	Varilla de control del crucero
33	812 00 00-53	Aro "E"	210	532 19 78-60	Ensamble del balancín del control del pedal
35	583 86 45-01	Varilla del freno de mano	211	532 12 01-83	Rodamiento de nylon
42	532 12 48-72	Cubierta del pedal	213	532 40 31-19	Perilla de control del crucero
43	874 18 04-12	Tornillo 1/4-20 x 3/4	214	532 41 68-63	Forro del pedal para avanzar
49	872 11 06-14	Perno	215	586 60-65-02	Forro del pedal para retroceder
50	532 19 43-27	Polea loca plana	220	532 19 89-08	Reflector (LD)
51	873 90 06-00	Tuerca 3/8-16	221	532 40 31-87	Abrazadera de retención del resorte de la manija
52	532 19 43-26	Polea loca con ranura en V con un desplazamiento	222	879 21 20-10	Arandela 21/32 x 1-1/4 x Calibre 10
56	592 85 53-01	Correa trapezoidal de la transmisión	225	532 40 73-11	Sujetador de la correa
64	532 19 78-65	Ensamble del eje Control del pedal de freno	226	532 40 71-09	Soporte de montaje
69	532 12 38-00	Arandela 1-1/32 x 1-5/8 x Calibre 16	282	874 49 05-48	Perno 5/16-18 x 3.0 Gr 5
70	532 43 96-61	Ensamble del console	284	532 41 76-93	Tuerca 1/4-20
73	874 49 05-44	Perno 5/16-18 x 3 Gr. 5	304	532 42 33-03	Horquilla para el cabello suave Zonc .059 x 1.125
74	532 14 24-32	Tornillo 1/4 x 1/2	366	580 62 62-01	Soporte
80	589 33 34-02	Correa de torsión			
92	874 76 05-20	Perno 5/16-18 x 1/2			
99	582 40 47-01	Resorte			
116	873 90 05-00	Tuerca 5/16-18			
125	817 00 05-12	Tornillo 5/16-18 x 3/4			
153	532 12 47-88	Retén del resorte			
159	876 02 04-12	Pasador de chaveta de 1/8 x 3/4			
160	532 16 94-84	Abrazadera de retención			
161	532 10 57-09	Resorte de retorno del embrague			
163	532 40 72-46	Varilla de control del pedal			
166	532 42 91-64	Tuerca .625			
167	532 40 52-57	Pestillo del freno de mano			
170	532 19 43-22	Sujetador de la correa			
171	872 11 06-16	Perno 3/8-16 unc x 2			
183	587 58 74-01	Separador del eje			

NOTA: Las dimensiones de todos los componentes están expresadas en pulgadas americanas. 1 pulgada = 25,4 mm

TRACTOR - - MODELO NO. GT52XLSi (96043017801), PRODUCT NO. 960 43 01-78
MOTOR

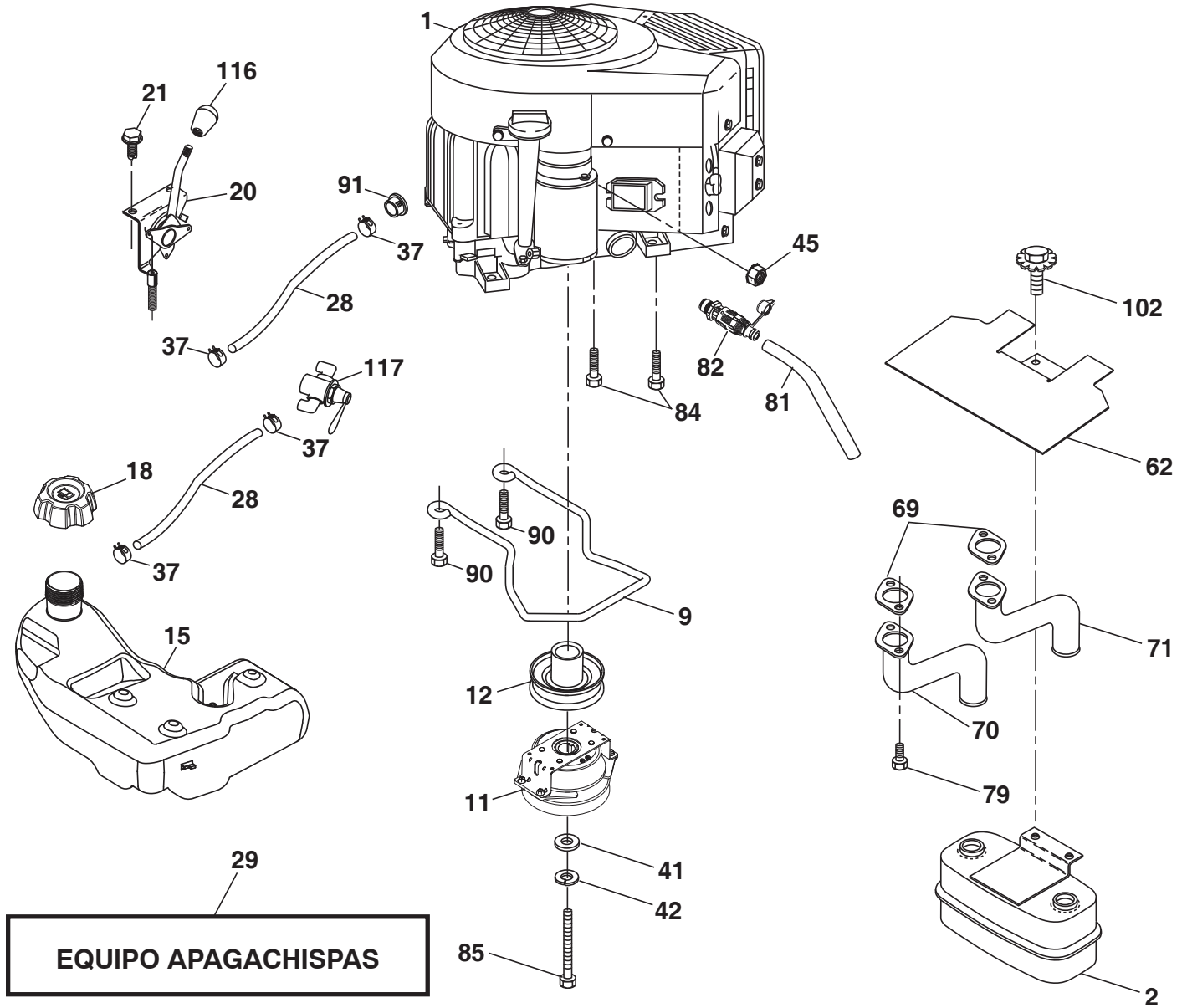

engine-tex_bs-2cyl_159

TRACTOR - - MODELO NO. GT52XLSi (96043017801), PRODUCT NO. 960 43 01-78 MOTOR

CÓDIGO No.	PIEZA No.	DESCRIPCIÓN
1	- - - - -	Motor B&S Modelo No. 44N877-0005-G1 (501260101) (Haga el pedido de las piezas al fabricante del motor.)
2	532 44 59-62	Silenciador
9	501 83 26-02	Ensamble del sujetador de la correa del motor
11	587 24 14-01	Embrague eléctrico
12	532 19 43-43	Polea del motor
15	532 43 80-21	Tanque de combustible de 4,0R
18	585 12 48-01	Ensamble de la tapa
20	587 24 27-01	Control de aceleración
21	532 41 63-58	Tornillo #10 x 0.750
28	532 40 11-35	Línea de combustible
29	532 13 71-80	Equipo apagachispas
37	532 12 34-87	Abrazadera de la manguera
41	532 12 61-97	Arandela 1-1/2 OD x 15/32 ID x .250
42	539 99 02-47	Arandela
45	873 51 04-00	Tuerca 1/4-20 unc
62	532 43 40-17	Silenciador con pantalla térmica
69	532 16 53-91	Junta
70	581 88 11-01	Tubo de escape izquierdo
71	581 88 10-01	Tubo de escape derecho
79	532 18 39-06	Tornillo 5/16-18 x 1
81	532 14 84-56	Tubo de drenaje
82	532 42 82-87	Drenaje del aceite
84	817 06 06-20	Tornillo 3/8-16 x 1-1/4
85	501 60 69-01	Perno 7/16-20 x 3.0 x Gr. 5
90	817 00 06-16	Tornillo 3/8-16 x 1
91	532 18 74-95	Buje
102	817 00 05-12	Tornillo 5/16 x 3/4
116	539 13 26-24	Perilla
117	532 42 08-28	Abastecza de combustible válvula

NOTA: Las dimensiones de todos los componentes están expresadas en pulgadas americanas. 1 pulgada = 25,4 mm

Para el servicio de motor y repuestos, llame el número de llamada gratuita para su fabricante de motor listó abajo:
Briggs & Stratton 1-800-233-3723

Información de Clasificación de Potencia del Motor

La clasificación de potencia para un modelo de motor a gas en particular se designa de acuerdo al código J1940 de SAE (Sociedad de Ingenieros Automotrices) (Procedimiento de Clasificación de Potencia & Torque del Motor Pequeño), y la clasificación de desempeño ha sido obtenida y corregida de acuerdo con el código J1995 de SAE (Revisión 2002-05). Los valores de torque se obtienen a 3060 RPM; los valores de potencia se obtienen a 3600 RPM. La potencia bruta actual del motor será inferior y está afectada, entre otras cosas, por las condiciones ambientales operativas y la variabilidad de motor a motor. Dado ambos un amplio conjunto de productos en los cuales son puestos nuestros motores, y la variedad de emisiones ambientales aplicables al operar el equipo, el motor a gas no desarrollará la potencia nominal cuando sea usado en una parte del equipo acoplado (potencia real "en el-sitio" o potencia neta). Esta diferencia se debe a una variedad de factores que incluyen, pero que no están limitados a, accesorios (filtro de aire, sistema de escape, sistema de carga, sistema de enfriamiento, carburador, bomba de combustible, etc.) limitaciones de la aplicación, condiciones ambientales de operación (temperatura, humedad, altitud), y la variabilidad de motor a motor. Debido a las limitaciones, Briggs & Stratton puede sustituir este motor con clasificación de potencia más alta por esta serie de motor.

TRACTOR - - MODELO NO. GT52XLSi (96043017801), PRODUCT NO. 960 43 01-78
ENSAMBLE DE LA DIRECCIÓN

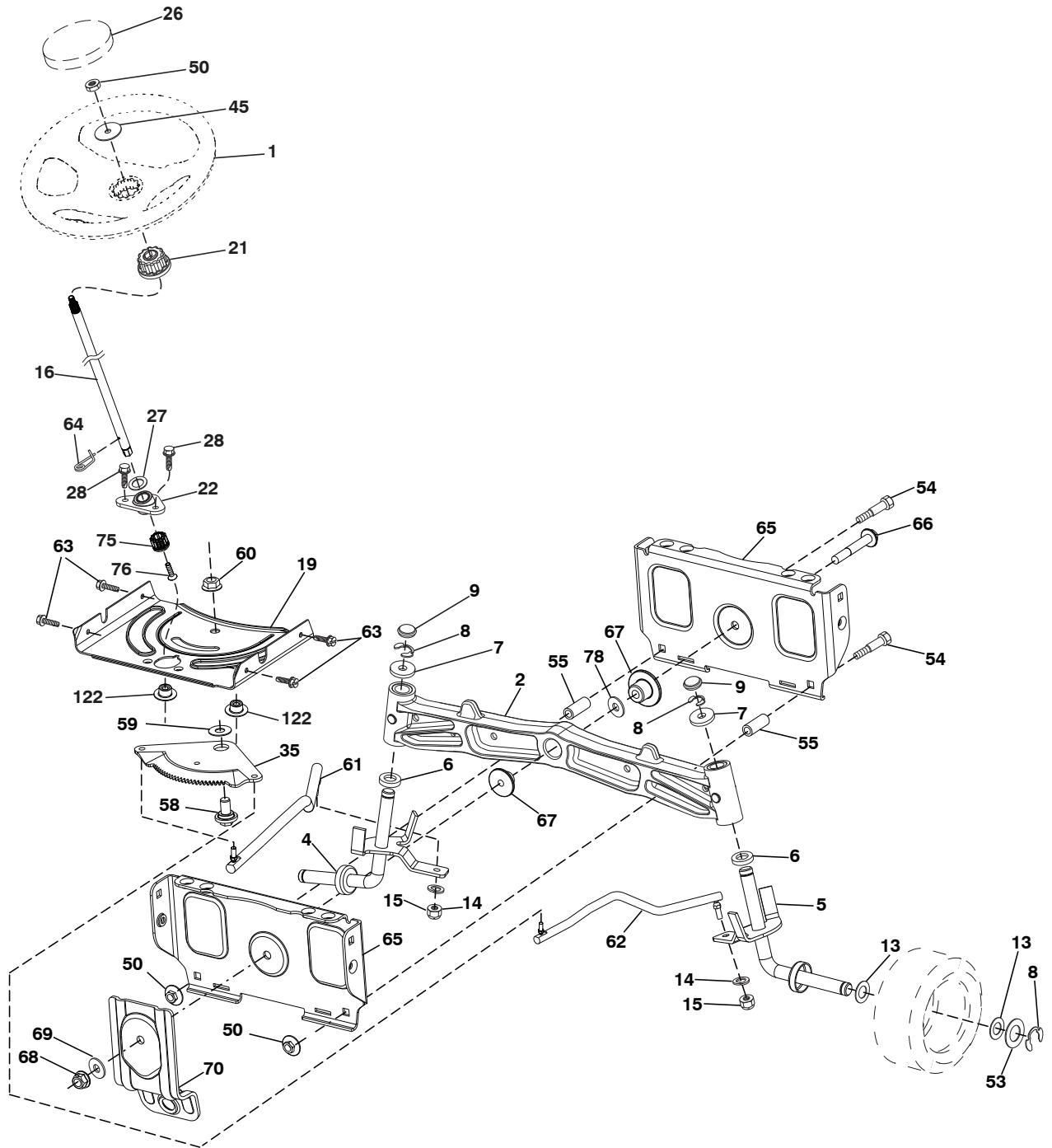

Steering-tex_LEGND2_58

**TRACTOR - - MODELO NO. GT52XLSi (96043017801), PRODUCT NO. 960 43 01-78
ENSAMBLE DE LA DIRECCIÓN**

CÓDIGO No.	PIEZA No.	DESCRIPCIÓN
1	532 43 97-40	Volante de dirección
2	532 19 59-68	Ensamble del eje delantero
4	532 40 30-89	Ensamble del husillo izquierdo
5	532 40 30-90	Ensamble del husillo derecho
6	532 12 49-31	Pista del rodamiento para reforzar el impulso
7	532 12 17-48	Arandela 25/32 x 1-5/8 x calibre 16
8	812 00 00-29	Abrazadera del aro No. T5304-75
9	532 12 12-32	Tapa del husillo
13	532 12 17-49	Arandela 25/32 x 1-1/4 x calibre 16
14	539 99 01-18	Arandela 3/8
15	873 54 06-00	Tuerca 3/8-24 unf
16	587 01 60-02	Eje de dirección
19	532 19 47-29	Placa de dirección
21	586 84 02-01	Adaptador del volante de dirección
22	585 02 98-02	Rodamiento
26	532 43 97-43	Inserto del volante de dirección
27	819 21 16-16	Arandela
28	817 00 06-12	Tornillo 3/8-16 x 3/4
35	532 19 47-32	Engranaje del sector de la placa
45	587 01 64-01	Arandela 3/8 ID 2-3/8 OD calibre 12 PLTD
50	873 90 06-00	Tuerca 3/8-16 unc
51	873 94 08-00	Tuerca 1/2-20 unf
53	532 18 89-67	Arandela .793 x 1.637 x .060
54	874 76 06-36	Perno 3/8-16 unc x 2-1/4
55	532 41 47-36	Espaciador
58	532 19 47-47	Perno
59	532 19 47-48	Arandela
60	873 97 10-00	Tuerca 5/8-11
61	532 19 47-40	Barra de acoplamiento izquierda
62	532 19 47-41	Barra de acoplamiento derecha
63	817 00 05-12	Tornillo 5/16-18 x 3/4
64	532 19 98-49	Abrazadera de retención del resorte de la dirección
65	532 19 47-34	Soporte delantero del eje
66	871 02 07-48	Perno 7/16-14 x 3
67	532 19 47-37	Buje
68	873 90 07-00	Tuerca 7/16-14 Gr. 5
69	532 19 91-62	Arandela 1.5 x .505 x .118
75	580 68 37-01	Piñón
76	580 68 36-01	Tornillo
70	585 33 88-01	Soporte
78	532 05 70-79	Arandela
122	532 44 49-62	Tapa

NOTA: Las dimensiones de todos los componentes están expresadas en pulgadas americanas. 1 pulgada = 25,4 mm

TRACTOR - - MODELO NO. GT52XLSi (96043017801), PRODUCT NO. 960 43 01-78
PLATAFORMA DE LA CORTADORA DE CÉSPED

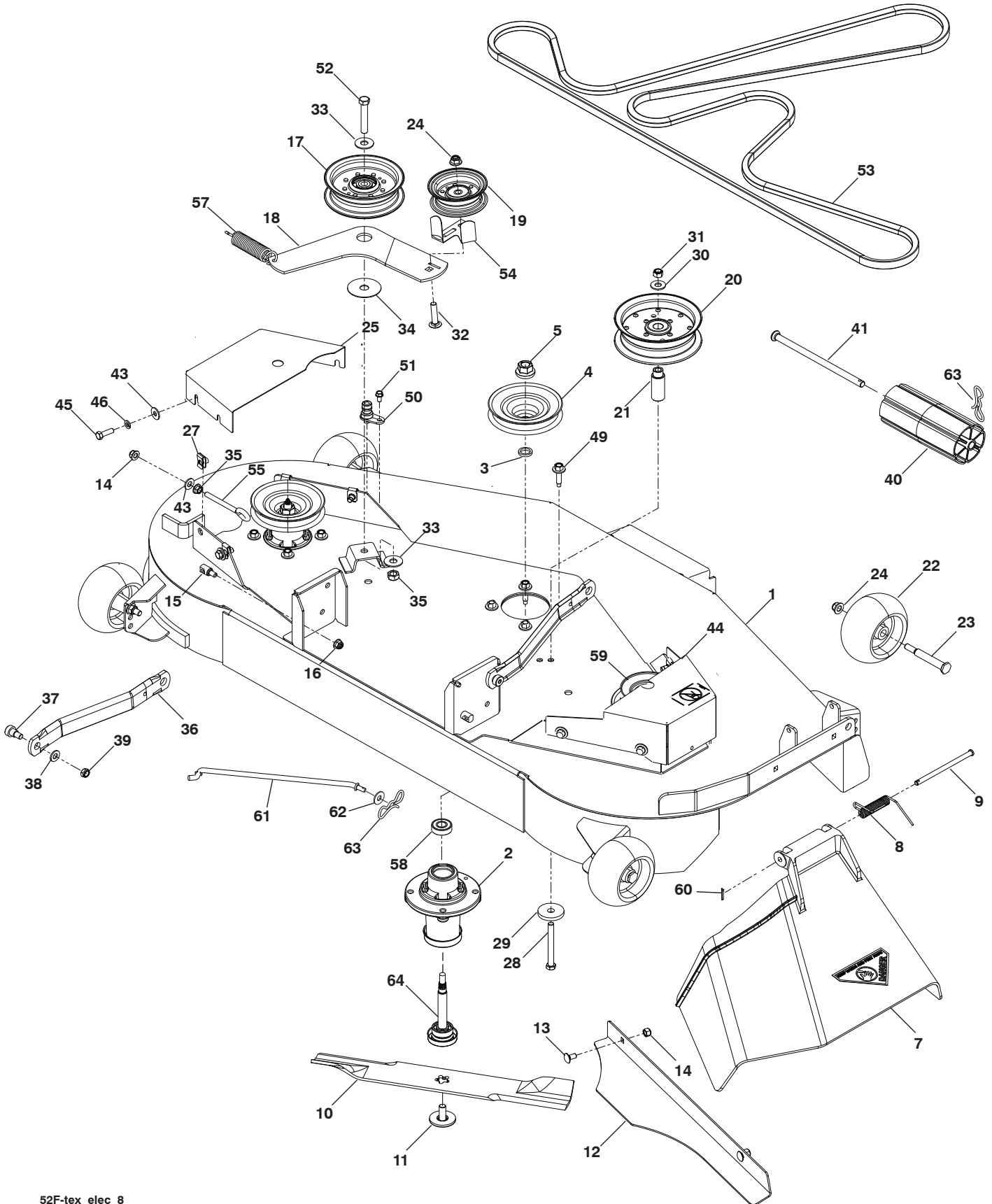

**TRACTOR - - MODELO NO. GT52XLSi (96043017801), PRODUCT NO. 960 43 01-78
PLATAFORMA DE LA CORTADORA DE CÉSPED**

CÓDIGO No.	PIEZA No.	DESCRIPCIÓN	CÓDIGO No.	PIEZA No.	DESCRIPCIÓN
1	574 80 44-02	Cubierta 52"	36	532 19 51-85	Suspensión posterior del brazo
2	539 13 18-98	Ensamble de la cubierta	37	539 11 36-21	Sb 3/8-16 x 3/8 Skt Hd
3	539 18 76-90	Arandela	38	819 13 13-16	Arandela 13/32 x 13/16 x calibre 16
4	532 17 43-75	Polea	39	539 20 02-82	Tuerca 3/8-16
5	539 40 02-34	Tuerca 9/16	40	532 17 60-66	Rodillo de la nariz
7	539 11 07-33	Canal inclinado de la descarga, 52"	41	532 17 91-27	Rod, rodillo de la nariz
8	539 11 07-35	Resorte - torsión	43	819 12 14-14	Arandela 3/8 x 7/8 x grado 14
9	539 11 07-36	Pin, horquilla 5/16 x 5.19	44	575 96 73-02	Protector de la correa LD
10	574 87 08-01	Lámina, 16-1/4"	45	874 78 05-16	Perno 5/16-18 x 1
11	532 19 30-03	Perno, 7/16	46	539 99 01-87	Arandela 5/16
12	574 87 50-02	Placa del confinamiento	49	584 95 39-01	Perno 313-18 x 1.19
13	872 11 05-05	Perno 5/16-18 x 5/8	50	532 41 55-98	Puerto del derrubio
14	873 80 05-00	Tuerca 5/16-18	51	817 49 04-08	Perno 1/4-20 x 1/2
15	532 19 51-61	Fastner del perno prisionero	52	874 78 07-40	Hcs 7/16-14 x 2-1/2
16	873 90 06-00	Tuerca 7/16-14 grado 5	53	574 84 56-03	Correa, cubierta
17	532 19 61-04	Polea más ociosa	54	532 14 10-43	Protector, correa
18	574 84 18-02	Brazo más ocioso	55	539 11 55-74	Perno de argolla 5/16 x 3-1/2
19	532 17 79-68	Polea más ociosa	57	539 10 68-50	Resorte
20	539 13 27-28	Polea más ociosa	58	532 11 04-85	Rodamiento de bolitas
21	575 22 45-01	Buje más ocioso	59	575 35 29-01	Polea
22	532 13 39-57	Rueda, calibrador	60	532 16 94-84	Detenedor del clip
23	532 19 34-06	Perno	61	532 40 03-37	Varilla
24	521 99 65-01	Tuerca 3/8-16	62	819 13 13-12	Arandela 13/32 x 13/16 x calibre 12.
25	575 22 47-02	Protector, correa LI	63	532 19 42-08	Pasador de chaveta de 5/16 con bloqueo en forma de mariposa
27	539 10 47-63	Detenedor 5/16	64	532 18 72-91	Conjunto del eje del mandril
28	539 10 82-71	Hcs 3/8-16 x 3-1/2 grado 5	--	532 41 64-05	Accesorio del conexión
29	539 10 65-04	Arandela	--	501 69 86-01	Cubierta del cortacéspedes completa
30	819 14 16-14	Arandela 3/8			
31	539 97 69-79	Tuerca 3/8-16			
32	539 99 09-23	Rhsnb 3/8-16 x 1-3/4 grado 5			
33	539 10 48-64	Arandela 7/16 Flat			
34	532 17 85-15	Arandela			
35	873 90 07-00	Tuerca 7/16-14 grado 5			

NOTA: Las dimensiones de todos los componentes están expresadas en pulgadas americanas. 1 pulgada = 25,4 mm

TRACTOR - - MODELO NO. GT52XLSi (96043017801), PRODUCT NO. 960 43 01-78
ELEVACIÓN DE LA CORTADORA DE CÉSPED

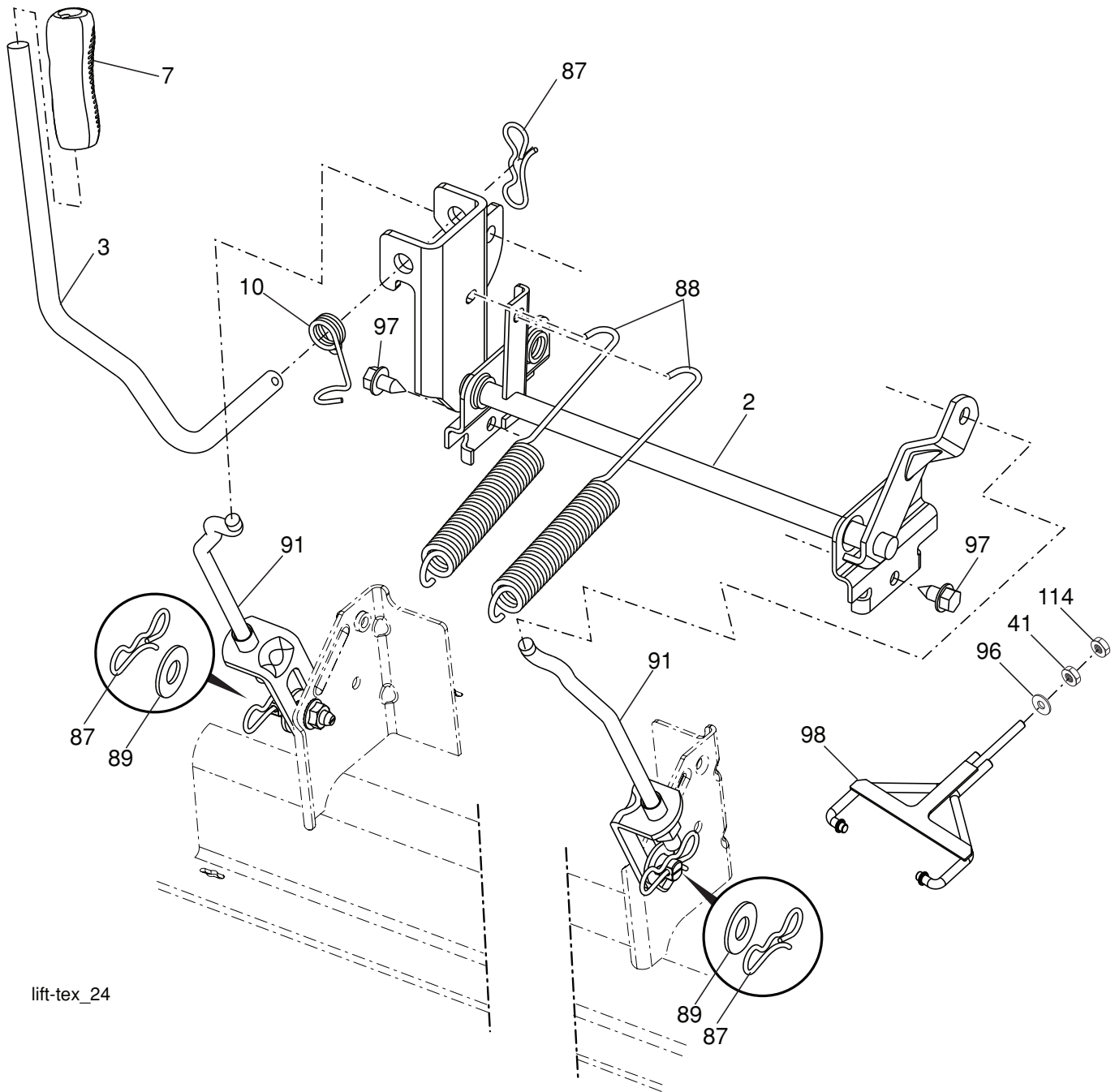

lift-tex_24

CÓDIGO No.	PIEZA No.	DESCRIPCIÓN
2	532 42 20-27	Ensamble del eje de la elevación
3	532 19 52-30	Ensamble de la palanca de elevación derecha
7	580 96 23-01	Mango de la palanca
10	532 19 63-14	Resorte de torsión
41	532 17 59-94	Tuerca
87	532 19 42-09	Pasador de chaveta de 7/16 con bloqueo en forma de mariposa
88	532 19 53-04	Resorte de ayuda de la elevación
89	819 19 19-12	Arandela de zinc transparente
91	532 40 34-07	Soporte

CÓDIGO No.	PIEZA No.	DESCRIPCIÓN
96	532 19 52-63	Buje
97	817 00 06-12	Tornillo 3/8-16 x .75
98	574 82 25-01	Acoplamiento frontal de la elevación de la cortadora de césped
114	873 36 07-00	Tuerca 7/16-20

NOTA: Las dimensiones de todos los componentes están expresadas en pulgadas americanas. 1 pulgada = 25,4 mm

**TRACTOR - - MODELO NO. GT52XLSi (96043017801), PRODUCT NO. 960 43 01-78
ENSAMBLE DEL ASIENTO**

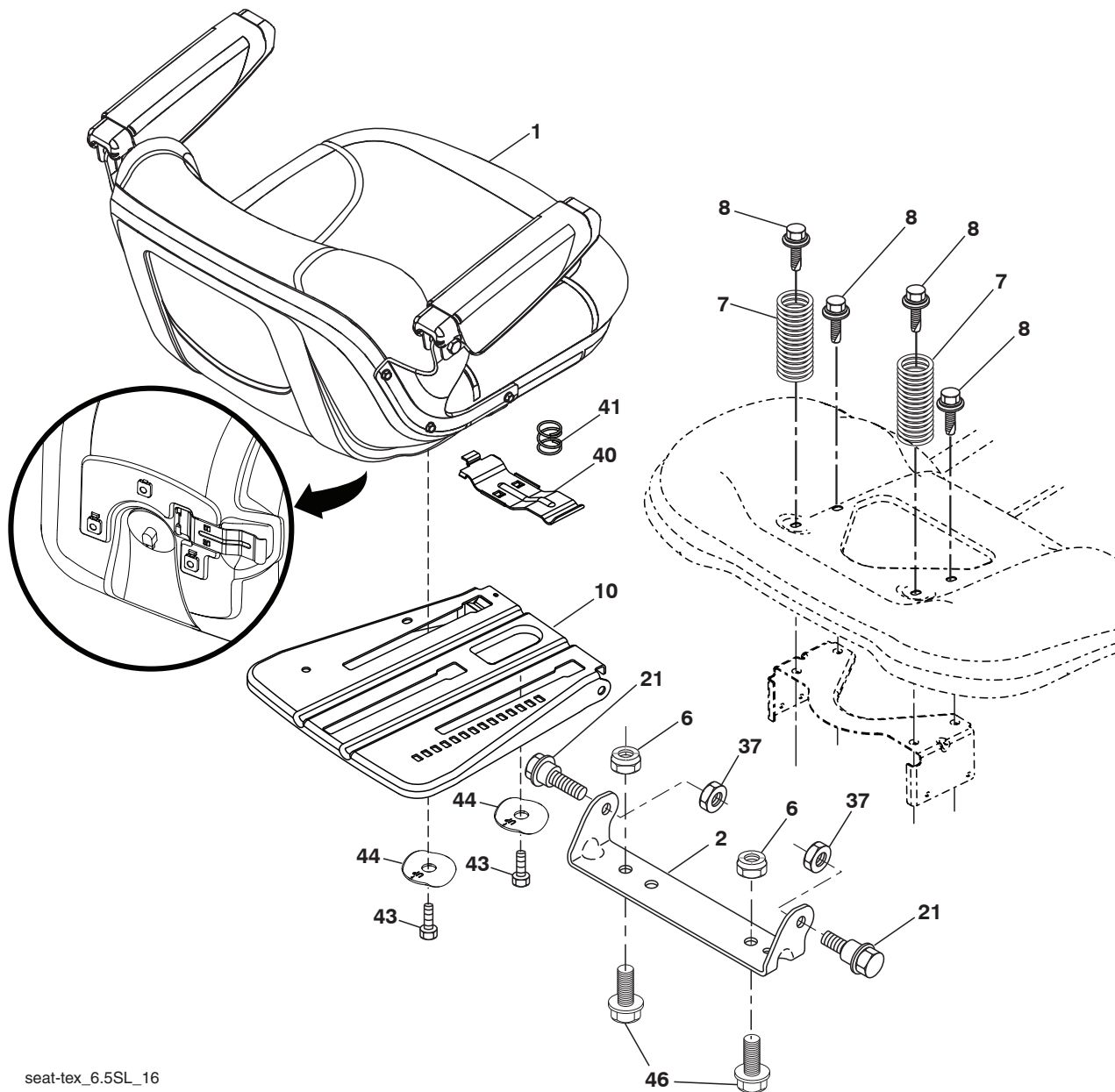

seat-tex_6.5SL_16

CÓDIGO No.	PIEZA No.	DESCRIPCIÓN
1	588 55 67-01	Asiento
2	532 18 01-66	Soporte pivotante del guardabarros
6	873 80 06-00	Tuerca de presión c/aislamiento de 3/8-16 unc
7	589 48 35-01	Resorte del asiento
8	532 17 18-77	Perno 5/16-18 unc x 3/4
10	587 23 20-02	Bandeja del asiento
21	587 90 78-01	Perno 5/16-18 x 5/8
37	873 80 05-00	Tuerca de presión de 5/16-18 unc
40	532 43 98-71	Manija para deslizar el asiento

CÓDIGO No.	PIEZA No.	DESCRIPCIÓN
41	532 19 82-00	Resorte para trabar el asiento
43	874 76 06-12	Perno de cabeza hexagonal con aleta de 3/8-16 unc x 3/4
44	501 05 18-01	Arandela
46	588 09 04-01	Perno 3/8-16 x 1; 1.25 OD

NOTA: Las dimensiones de todos los componentes están expresadas en pulgadas americanas. 1 pulgada = 25,4 mm

**TRACTOR - - MODELO NO. GT52XLSi (96043017801), PRODUCT NO. 960 43 01-78
CALCOMANÍAS**

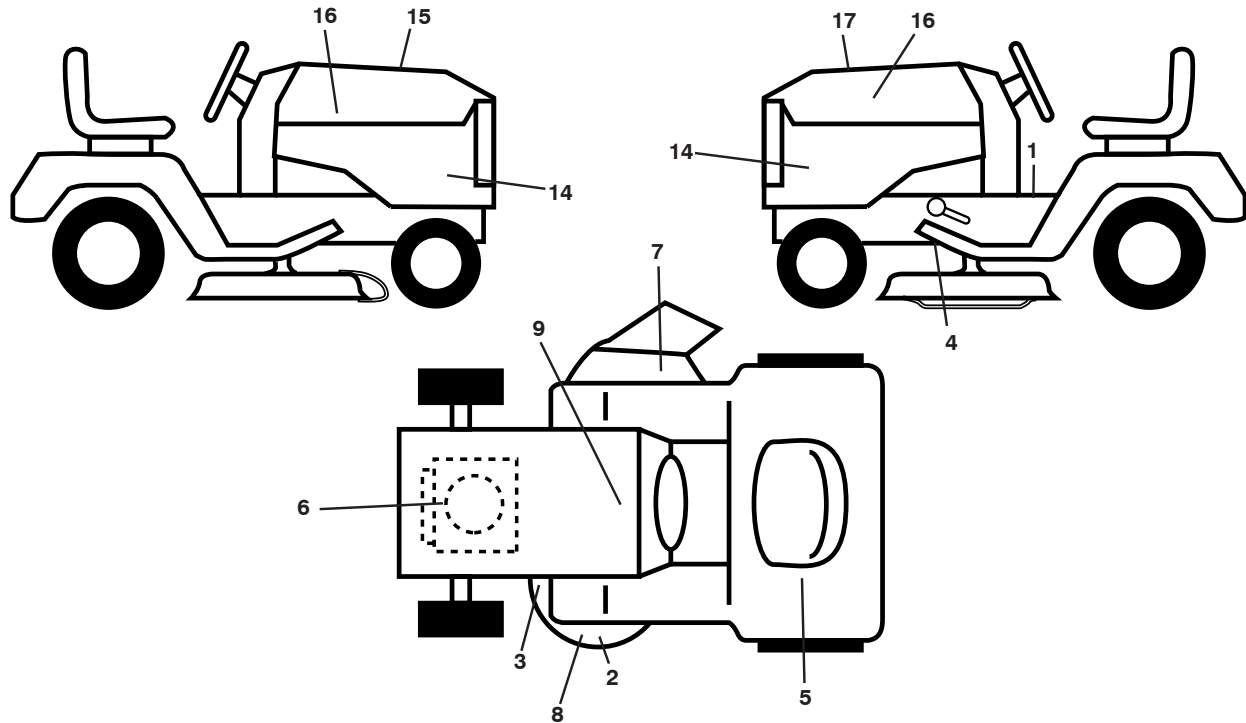

CÓDIGO No.	PIEZA No.	DESCRIPCIÓN	CÓDIGO No.	PIEZA No.	DESCRIPCIÓN
1	583 83 44-01	Calcomanía para el guardabarros del operador	14	585 68 15-01	Calcomanía para el panel lateral
2	581 72 43-01	Calcomanía de ningún paso	15	532 42 38-29	Calcomanía del cliente
3	581 58 00-02	Calcomanía del diagrama de la cortadora de césped	16	581 62 73-01	Calcomanía para la capota
4	532 41 86-00	Calcomanía de pedal	17	586 06 70-01	Calcomanía de reemplazo
5	587 01 51-01	Calcomanía para advertencia	--	501 74 90-01	Calcomanía diferencial de bloqueo
6	586 00 07-01	Calcomanía para el motor	--	581 72 48-01	Calcomanía para la desviación
7	584 90 46-01	Calcomanía para advertencia	--	532 43 98-82	Forro del apoyo para los pies (LI)
8	532 44 81-21	Calcomanía	--	532 43 98-81	Forro del apoyo para los pies (LD)
9	532 14 50-05	Calcomanía de peligro/punto de interconexión	--	115 78 87-26	Manual del operario (Inglés/Español)
			--	115 78 88-27	Manual de repuestos (Inglés/Español)
			--	587 71 00-26	Guía de inicio rápido (Inglés/Español)

RUEDAS Y NEUMÁTICOS

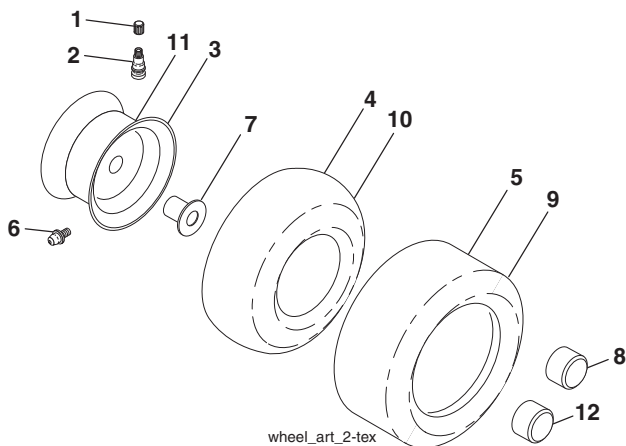

CÓDIGO No.	PIEZA No.	DESCRIPCIÓN
1	532 05 91-92	Tapa de la válvula del neumático
2	532 06 51-39	Vástago de la válvula
3	532 18 18-39	Ensamble de las llantas delanteras
4	532 00 81-34	Cámara delantera (Mantenimiento sólo)
5	532 16 10-24	Neumático delantero 16 x 6.5-8
6	532 12 49-57	Accesorio para engrasar (solo para la rueda delantera)
7	532 12 49-59	Rodamiento de la brida (solo para la rueda delantera)
8	532 17 50-39	Tapa del eje frente
9	532 17 04-53	Neumático trasero 23 x 10.5-12
10	532 00 71-54	Cámara trasera (Mantenimiento sólo)
11	532 14 45-10	Ensamble trasero de la llanta
12	501 50 31-01	Tapa del eje trasero negro
--	532 14 43-34	Sellador para neumáticos (tubo de 10 onzas [283 gr])

NOTA: Las dimensiones de todos los componentes están expresadas en pulgadas americanas. 1 pulgada = 25,4 mm

NOTES/AVISO



www.husqvarna.com