

Repair Parts Manual
Manual De Repuestos
YTH18K46/96043023200

Please read the operator's manual carefully and make sure you understand the instructions before using the machine.

Por favor lea cuidadosamente y comprenda estas instrucciones antes de usar esta maquina.



English/Spanish

115 86 30-26 Rev. 4



HOW TO USE THIS MANUAL

This manual is designed to provide the customer with a means to identify the parts on his/her tractor when ordering repair parts. The illustrations may or may not represent the actual assemblies; therefore, it is not recommended to use this manual as a guide to assemble or disassemble the tractor. Some hardware and parts are drawn larger in order to more readily identify them.

Each tractor has its own model number. The model number for your tractor can be found on the fender under the seat.

Support / Help

If you require assistance or have questions concerning the application, operation, maintenance or parts for your product:

- Visit our website: www.husqvarna.com
- Call Us Toll Free: 1-800-487-5951

When ordering parts, always give the following information:

- Product - "TRACTOR"
- MODEL NUMBER - "YTH18K46" (96043023200)"
- Part Number
- Part Description

TABLE OF CONTENTS

SCHEMATIC	3
ELECTRICAL.....	4-5
CHASSIS	6-7
DRIVE.....	8-9
ENGINE.....	10-11
STEERING	12-13
MOWER DECK.....	14-15
MOWER LIFT.....	16
SEAT	17
DECALS.....	18

COMO UTILIZAR ESTE MANUAL

Este manual está diseñado para brindarle al comprador un medio para identificar las piezas del tractor para cuando necesite hacer el pedido de un repuesto. Las ilustraciones pueden o no representar los ensambles reales; por lo tanto, no se recomienda utilizar este manual como una guía para ensamblar o desarmar el tractor. Algunos accesorios y piezas están dibujados en tamaños más grandes para identificarlos con mayor facilidad.

Cada tractor tiene su propio número de modelo. El número de modelo del tractor se encuentra en el guardabarros debajo del asiento.

Soporte / Ayuda

Si necesita asistencia o tiene alguna pregunta acerca de la aplicación, operación, mantenimiento o piezas de su producto:

- Visite nuestro sitio web: www.husqvarna.com
- Llámenos de manera gratuita al: 1-800-487-5951

Cuando haga el pedido de una pieza, siempre brinde la siguiente información:

- Producto: "TRACTOR"
- NÚMERO DE MODELO: "YTH18K46" (96043023200)"
- Número de pieza
- Descripción de la pieza

ÍNDICE

DIAGRAMA.....	19
DIAGRAMA ELÉCTRICO.....	20-21
CHASIS	22-23
TRANSMISIÓN	24-25
MOTOR.....	26-27
DIRECCIÓN	28-29
PLATAFORMA DE LA CORTADORA DE CÉSPED.....	30-31
ELEVACIÓN DE LA CORTADORA DE CÉSPED.....	32
ASIENTO.....	33
CALCOMANÍAS.....	34

TRACTOR - MODEL NO. YTH18K46 (96043023200), PRODUCT NO. 960 43 02-32 SCHEMATIC

SCH10

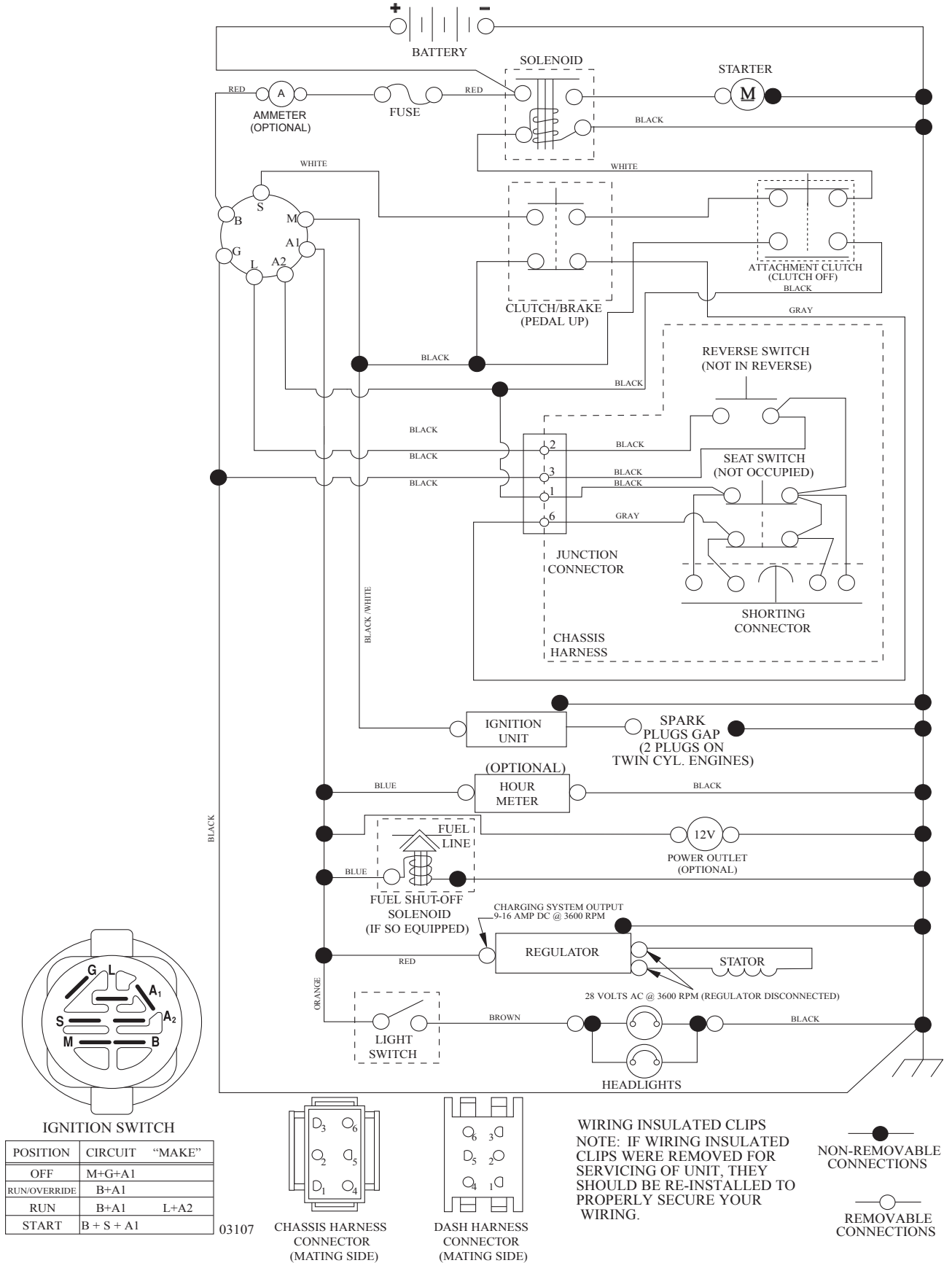

**TRACTOR - MODEL NO. YTH18K46 (96043023200), PRODUCT NO. 960 43 02-32
ELECTRICAL**

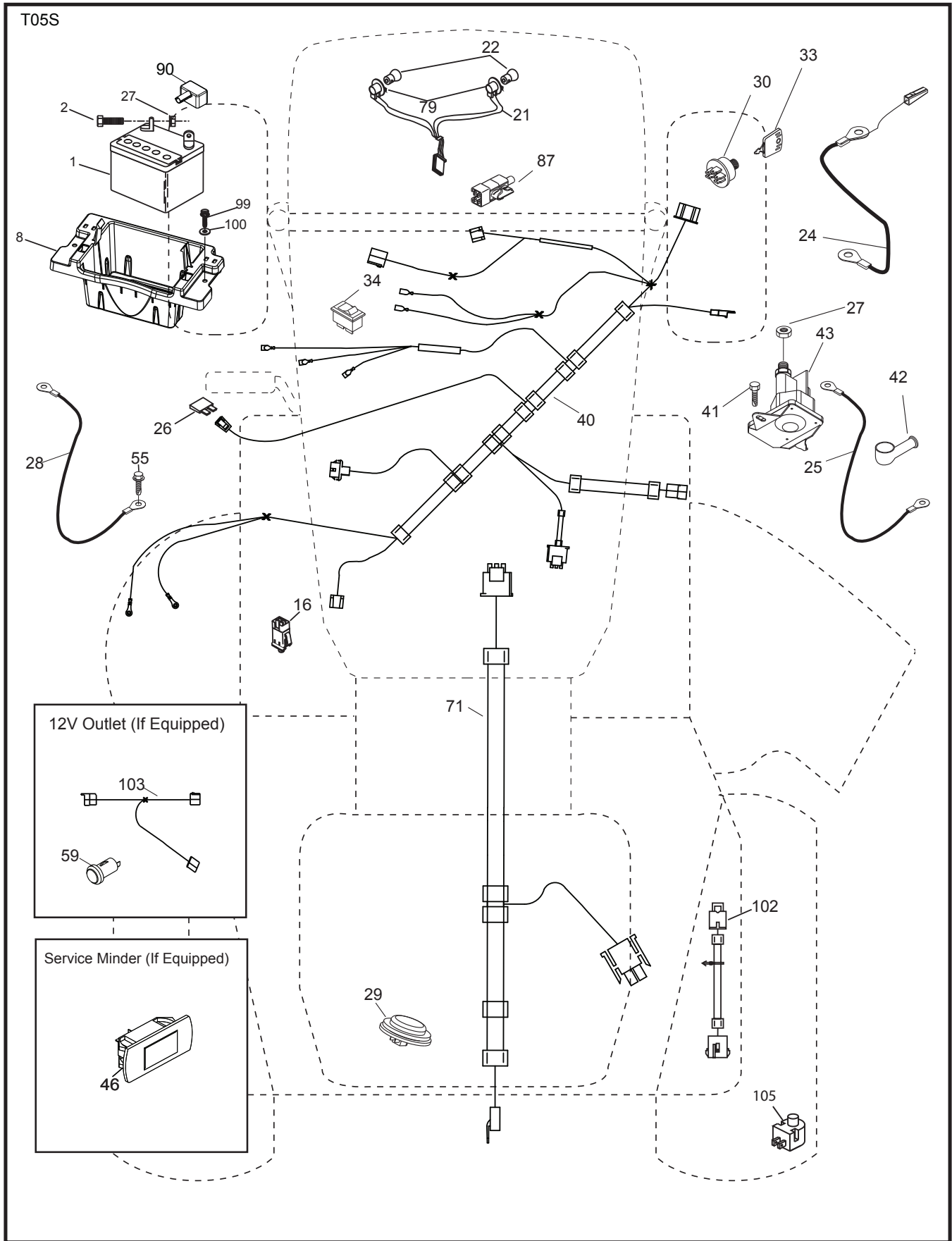

**TRACTOR - MODEL NO. YTH18K46 (96043023200), PRODUCT NO. 960 43 02-32
ELECTRICAL**

KEY NO.	PART NO.	DESCRIPTION
1	532 16 34-65	Battery
2	874 76 04-12	Bolt Hex Head 1/4-20 x 3/4
8	532 41 41-26	Box Battery
16	532 17 61-38	Switch Interlock Push-In
21	532 40 02-52	Harness Socket Light w/4152J
22	532 00 41-52	Bulb Light
24	585 55 56-01	Cable Frt Battery w/Wire
25	585 55 55-01	Cable Starter
26	532 17 51-58	Fuse
27	873 51 04-00	Nut Keps Hex 1/4-20 unc
28	532 41 65-88	Cable, Ground
29	532 40 15-45	Switch, Seat
30	532 19 33-50	Switch, Ign
33	532 41 19-33	Key/Chain
34	532 11 07-12	Switch Light/Reset
40	501 13 30-01	Harness Ign. Dash
41	817 72 04-08	Screw THD Cut 1/4-20 x 1/2 TY23
42	532 13 15-63	Cover Terminal
43	582 04 28-01	Solenoid Starter
46	586 16 18-01	Gauge Serviceminder Hrmtr
55	817 06 05-12	Screw Thdrol 5/16-18 x 3/4 TYTT
71	532 19 42-76	Harness Chassis
79	532 17 52-42	Socket Asm. Bulb
87	532 19 78-02	Switch Interlock Clutch
90	532 43 53-95	Cover Terminal
99	817 67 04-12	Screw Hx Wsh THDRL 1/4-20 x 3/4
100	819 09 14-16	Washer 9/32 x 7/8 x 16 Ga.
102	532 40 44-54	Harness Pigtail
105	532 40 75-68	Switch Reverse

NOTE: All component dimensions given in U.S. inches
1 inch = 25.4 mm

**TRACTOR - MODEL NO. YTH18K46 (96043023200), PRODUCT NO. 960 43 02-32
CHASSIS**

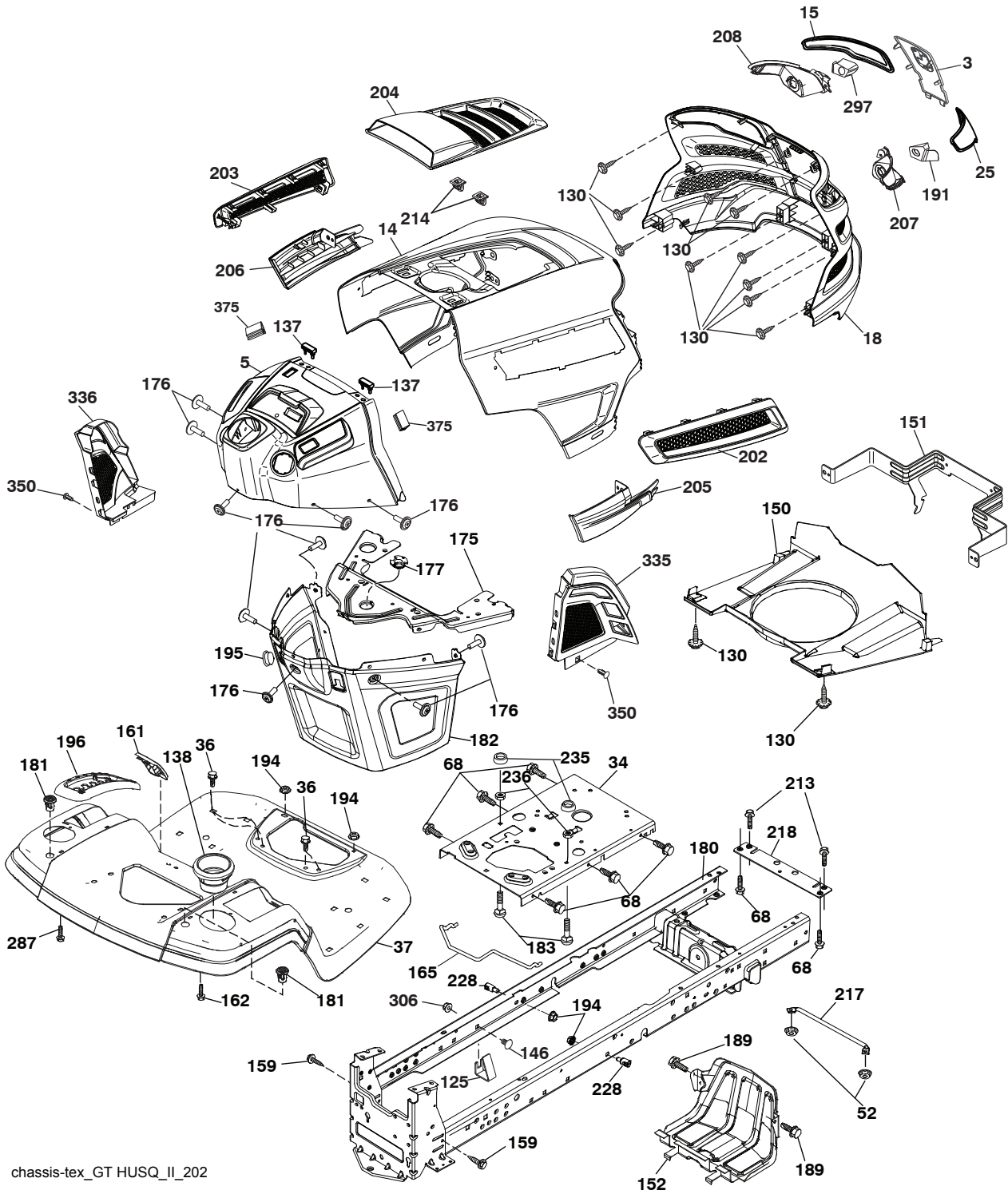

chassis-tex_GT HUSQ_II_202

**TRACTOR - MODEL NO. YTH18K46 (96043023200), PRODUCT NO. 960 43 02-32
CHASSIS**

KEY NO.	PART NO.	DESCRIPTION	KEY NO.	PART NO.	DESCRIPTION
3	532 44 44-81	Applique Sub Asm.	189	817 00 05-12	Screw 5/16-18 x 3/4 THDRL Black
5	589 34 34-01	Dash	191	532 43 74-55	Insert Reflective RH
14	532 44 11-77	Hood	194	873 90 05-00	Nut Lock Hex Flange 5/16-18
15	532 43 97-33	Lens LH	195	532 40 41-37	Plug Hole Dash Lower
18	532 44 06-53	Grille	196	532 43 96-47	Console Asm. Deck Lift
25	532 44 33-85	Lens RH	202	532 43 97-28	Vent Side Hood RH
34	580 91 08-01	Plate Engine	203	532 43 97-27	Vent Side Hood LH
36	817 06 05-12	Screw 5/16-18 x 3/4	204	532 44 44-84	Vent Top Hood
37	532 44 12-69	Fender	205	532 43 97-30	Skirt Hood Side RH
52	873 68 05-00	Nut Lock 5/16-18	206	532 43 97-29	Skirt Hood Side LH
68	817 49 05-08	Screw Thdrol 5/16-18 x 1/2	207	532 43 97-34	Bezel RH
125	581 68 48-01	Clip Fuel Line	208	532 43 97-35	Bezel LH
130	532 41 63-58	Screw #10 x 0.750	213	874 76 05-12	Bolt 5/16-18 x 3/4
137	532 40 75-90	Bumper Dash	214	532 19 91-45	Clip Retainer Tinner
138	532 43 97-47	Cupholder	217	532 40 91-67	Rod Pivot
146	581 85 79-01	Bolt	218	532 19 63-95	X-Piece Hood Stop
150	532 43 97-31	Air Duct	228	532 19 51-61	Stud Fastner
151	532 43 66-70	Bracket Pivot	235	532 40 61-29	Spacer Fender
152	532 43 98-70	Shield Browning	236	873 93 05-00	Nut Lock 5/16-18 unc
159	817 00 06-12	Screw Hexwsh Thrd 3/8-16 x 3/4	287	817 60 04-06	Screw 1/4-20 x 3/8
161	532 43 97-81	Console Fuel Window	297	532 43 74-56	Insert Reflective LH
162	532 14 24-32	Screw	306	873 90 06-00	Nut Lock
165	532 19 68-26	Support Tank Rear	335	532 44 82-04	Cover RH
175	532 19 63-04	Crossmember	336	532 44 53-09	Cover LH
176	532 40 07-76	Screw 10-24 x 5/8	350	532 44 51-43	Clip X-mas Tree
177	532 19 52-28	Bushing Steering	375	586 90 82-01	Bumper Dash
180	532 19 54-57	Chassis			
181	532 43 97-46	Bushing Mtg. Fender Crgo			
182	532 40 68-59	Dash Lower			
183	874 52 05-20	Bolt 5/16-18 x 1-1/4			

NOTE: All component dimensions given in U.S. inches
1 inch = 25.4 mm

TRACTOR - MODEL NO. YTH18K46 (96043023200), PRODUCT NO. 960 43 02-32 DRIVE

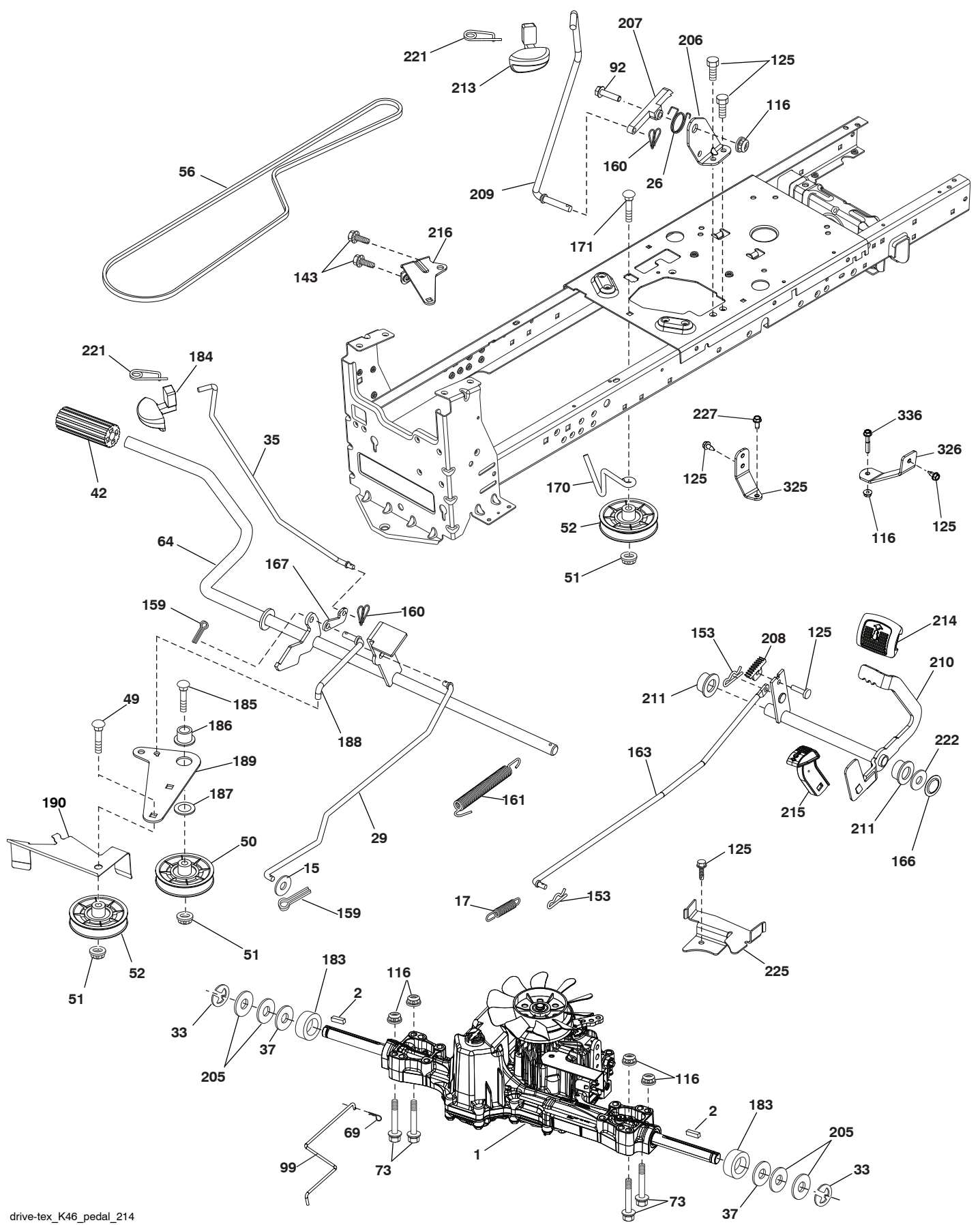

drive-tex_K46_pedal_214

**TRACTOR - MODEL NO. YTH18K46 (96043023200), PRODUCT NO. 960 43 02-32
DRIVE**

KEY NO.	PART NO.	DESCRIPTION	KEY NO.	PART NO.	DESCRIPTION
1	---	Transaxle, Tufftorq K46BT (426120) (Order parts from transaxle manufacturer.)	170	532 19 43-22	Keeper V-Idler
2	532 12 35-83	Key Square	171	872 11 06-16	Bolt 3/8-16 unc x 2
15	819 13 13-16	Washer 13/32 x 13/16 x 16 Ga.	183	532 13 70-57	Spacer Axle
17	532 41 36-78	Spring, Brake	184	587 65 37-01	Handle Parking Brake
26	532 19 96-79	Spring Return Cruise	185	872 11 06-22	Bolt
29	532 40 38-06	Rod, Brake	186	532 19 43-21	Spacer Retainer
33	812 00 00-01	Ring E	187	819 13 32-10	Washer
35	583 86 45-01	Rod, Brake, Park	188	582 21 70-01	Link Clutch Ground Drive, Long
37	532 18 89-67	Washer .793 x 1.637 x 060	189	532 19 43-17	Bellcrank Ground Drive
42	532 12 48-72	Cover, Foot Pedal	190	532 19 43-18	Keeper Bellcrank Ground Drive
49	872 11 06-14	Bolt	205	532 12 17-48	Washer 25/32 x 1-5/8 x 16 Ga.
50	532 19 43-27	Pulley Idler Flat	206	532 44 85-96	Bracket Mount Latch Cruise
51	873 90 06-00	Lock Nut 3/8-16	207	587 03 14-01	Latch Control Cruise
52	532 19 43-26	Idler V-Groove	208	532 19 78-69	Gear Sector Control Cruise
56	532 13 09-69	V-Belt, Drive	209	532 19 95-92	Rod Control Cruise
64	532 19 78-65	Shaft Asm. Pedal Brake Control	210	532 40 09-80	Rocker Asm. Pedal Control
69	532 42 33-03	Hairpin Soft Zink .059 x 1.125	211	532 12 01-83	Bearing Nylon
73	874 49 05-40	Bolt Hex 5/16-18 x 2 1/2 G.5	213	532 40 31-19	Knob Control Cruise
92	874 76 05-20	Bolt Fin Hex 5/16-18 unc x 1.25	214	532 42 12-63	Pedal Forward
99	582 40 45-01	Rod Spring Bypass	215	586 60 65-02	Pedal Reverse
116	873 90 05-00	Nut Lock Hex Flange 5/16-18	216	532 19 61-31	Bracket Pulley Idler
125	817 00 05-12	Screw 5/16-18 x 3/4	221	532 40 31-87	Retainer Spring Clip Handle
143	817 49 05-08	Screw 5/16-18 x 1/2	222	879 21 20-10	Washer 21/32 x 1-1/4 10 Ga.
153	532 12 47-88	Retainer Spring 1"	225	532 40 33-19	Keeper Belt Transaxle
159	876 02 04-12	Pin Cotter 1/8 x 3/4	227	817 49 05-12	Screw 5/16-18 x 3/4
160	532 16 94-84	Retainer Clip	325	585 66 85-02	Torque Strap K46 LT RH
161	532 10 57-09	Spring, Return, Clutch	326	585 67 08-02	Bracket TRQ STP 46 20" Tire RH
163	532 44 82-75	Rod Control	336	587 25 96-01	Bolt 5/16 - 18 x 1-3/4 Flanged
166	532 42 91-64	Nut Push			
167	532 40 52-57	Latch Brake Parking			

NOTE: All component dimensions given in U.S. inches
1 inch = 25.4 mm

**TRACTOR - MODEL NO. YTH18K46 (96043023200), PRODUCT NO. 960 43 02-32
ENGINE**

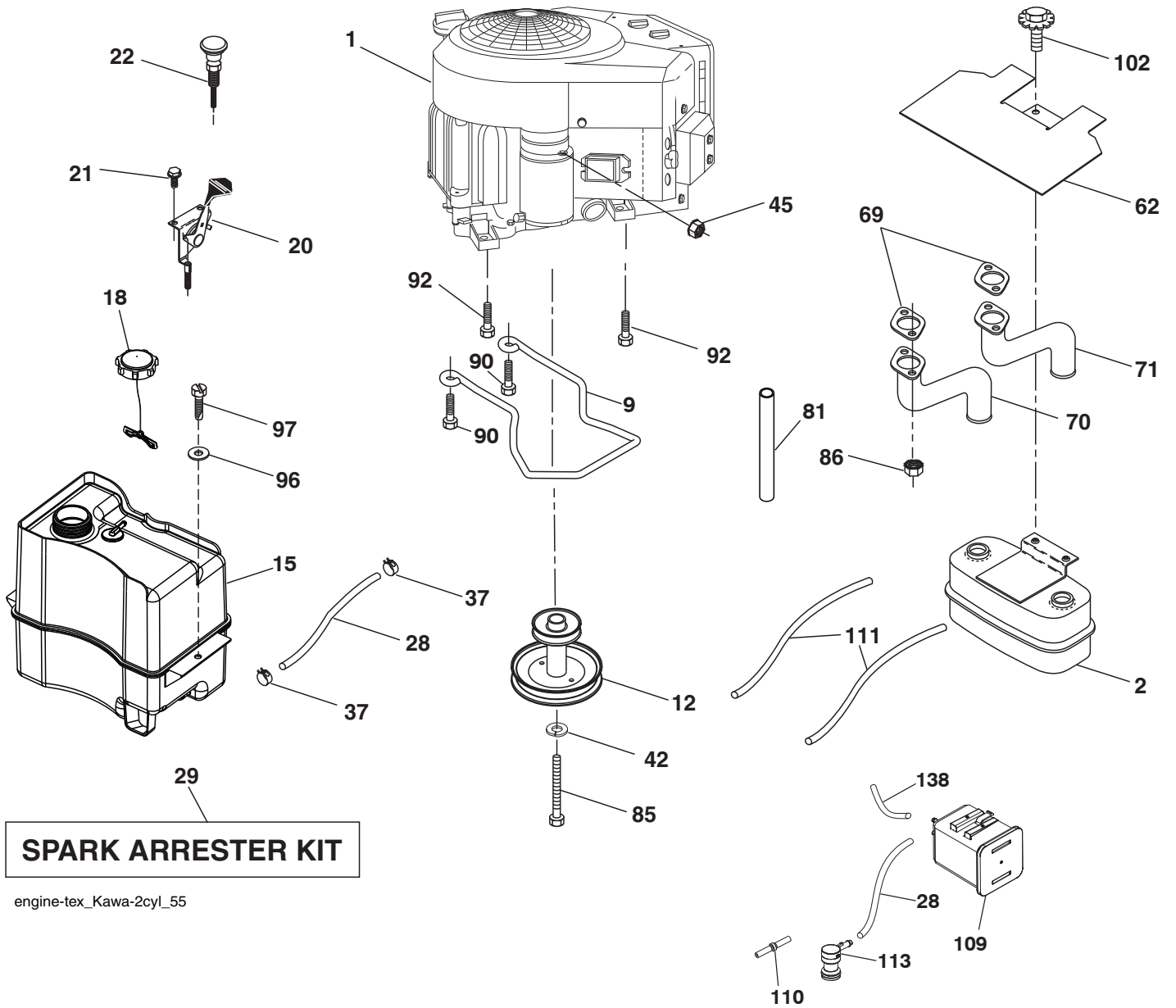

**TRACTOR - MODEL NO. YTH18K46 (96043023200), PRODUCT NO. 960 43 02-32
ENGINE**

KEY NO.	PART NO.	DESCRIPTION
1	-----	Engine Kawa Model No. FR600V-AS11 (581477001) (Order parts from engine manufacturer.)
2	589 81 87-01	Muffler
9	501 83 26-02	Keeper Belt Engine
12	586 72 89-01	Pulley Engine
15	539 90 05-01	Tank Fuel
18	585 12 48-01	Cap Asm
20	532 41 21-65	Control Throttle
21	532 41 63-58	Screw # 10 x 0.750
22	532 18 95-41	Choke Control
28	532 40 11-35	Fuel Line
29	532 13 71-80	Spark Arrester Kit
37	532 12 34-87	Clamp Hose
42	810 04 07-00	Washer Lock 7/16
45	873 51 04-00	Nut Keps Hex 1/4-20 unc
62	532 43 40-17	Shield Heat Muffler
69	532 17 81-51	Gasket
70	583 95 57-01	Tube Exhaust RH
71	583 95 56-01	Tube Exhaust LH
81	532 14 84-56	Tube Drain Oil
85	501 60 65-01	Bolt Hex 7/16-20 x 4 Gr 5-1.5
86	532 18 43-62	Nut Hex Flange Toplock M8-1.25
90	817 00 06-16	Screw 3/8-16 x 1
92	817 12 06-16	Screw 3/8-16 x 1
96	819 09 14-16	Washer 9/32 x 7/8 x 16 Ga.
97	817 67 04-12	Screw 1/4-20 x 3/4
102	817 00 05-12	Screw 5/16-18 x 3/4
109	532 41 41-14	Canister Carbon Filter
110	532 41 41-18	Valve Asm. Anti-Slosh
111	532 41 41-19	Purge Line Carb 3/16
113	532 41 41-27	Valve Slant
138	532 42 07-18	Purge Line 36" Rear

NOTE: All component dimensions given in U.S. inches
1 inch = 25.4 mm

For engine service and replacement parts, call the toll free number for your engine manufacturer listed below:

Kawasaki 1-949-460-5688

TRACTOR - MODEL NO. YTH18K46 (96043023200), PRODUCT NO. 960 43 02-32
STEERING ASSEMBLY

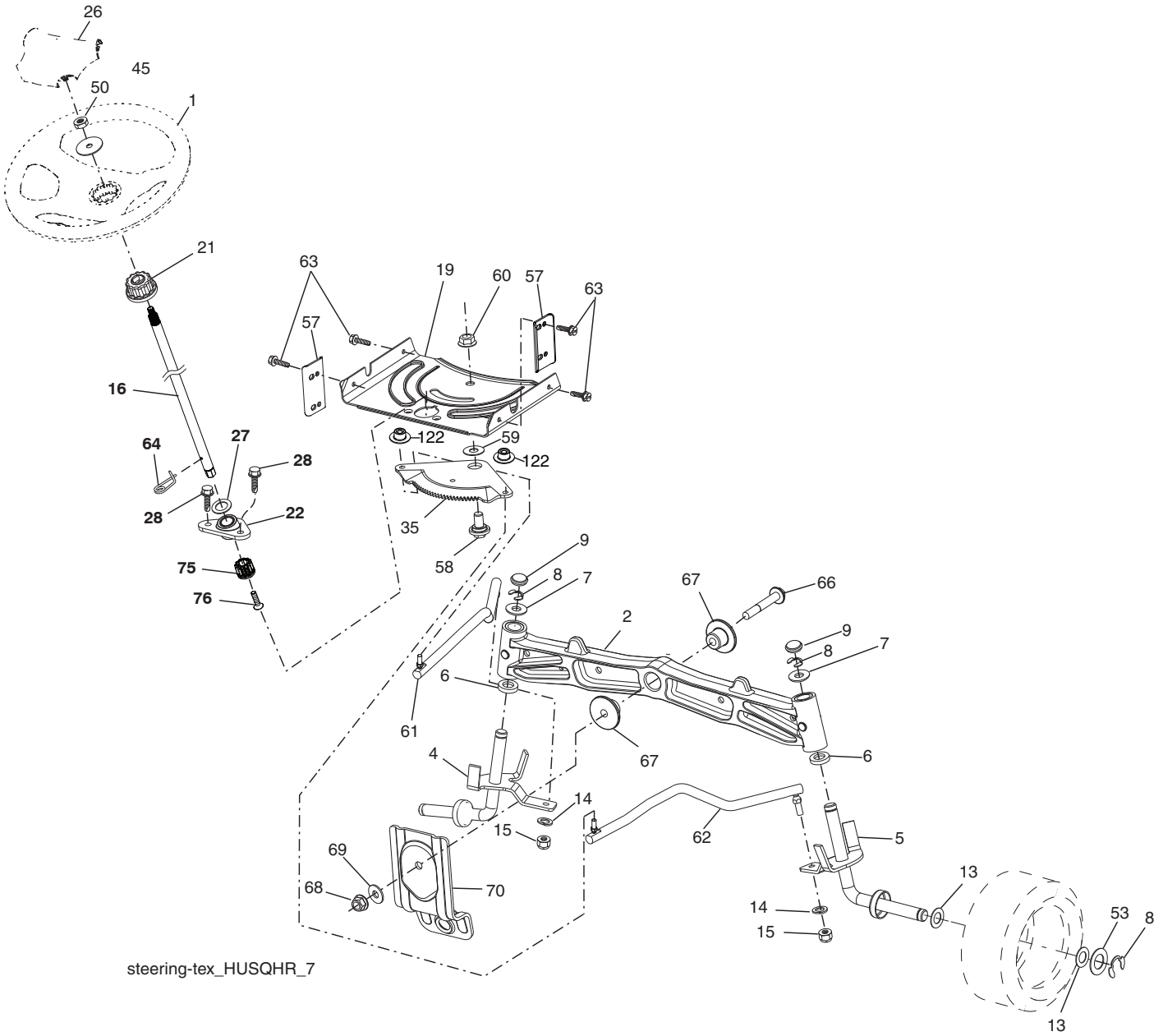

steering-tex_HUSQHR_7

**TRACTOR - MODEL NO. YTH18K46 (96043023200), PRODUCT NO. 960 43 02-32
STEERING ASSEMBLY**

KEY NO.	PART NO.	DESCRIPTION
1	532 43 97-40	Wheel, Steering
2	532 19 59-68	Axle Cast Iron
4	532 40 30-87	Spindle Asm., LH
5	532 40 30-88	Spindle Asm., RH
6	532 12 49-31	Washer, Thrust
7	532 12 17-48	Washer 25/32 x 1-5/8 x 16 Ga.
8	812 00 00-29	Ring, Klip #T5304-75
9	532 12 12-32	Cap, Spindle
13	532 12 17-49	Washer 25/32 x 1-1/4 x 16 Ga.
14	810 04 06-00	Washer, Lock Hvy Hlcl Spr 3/8
15	873 54 06-00	Nut, Crown Lock 3/8-24 unf
16	587 01 60-02	Steering Shaft
19	532 19 47-29	Plate Steering
21	586 84 02-01	Adapter Wheel Steering
22	585 02 98-02	Bearing
26	532 43 97-43	Insert, Wheel Steering
27	819 21 16-16	Washer
28	817 00 06-12	Screw 3/8-16 x 3/4
35	532 19 47-32	Gear, Sector Plate
45	587 01 64-01	Washer 3/8 ID 2-3/8 OD 12 Ga. PLTD
50	873 90 06-00	Nut Lock Flg 3/8-16 unc
53	532 18 89-67	Washer Hardened .793 x 1.637 x .060
57	532 40 74-65	Bracket Upstop
58	532 19 47-47	Bolt Shoulder Sector Pivot CFM
59	532 19 47-48	Washer Thrust Sector Steering
60	873 97 10-00	Nut Flange Lock 5/8-11
61	532 19 47-40	Draglink, LH
62	532 19 47-41	Draglink, RH
63	817 00 05-12	Screw 5/16-18 x 3/4
64	532 19 98-49	Retainer Clip Spring Steering
66	871 02 07-48	Bolt Hex Fghd 7/16-14 x 3 Serr
67	532 19 47-37	Bushing PM Front Axle
68	873 90 07-00	Nut Lock Flange 7/16-14 Gr. 5
69	532 19 91-62	Washer 1.5 x .505 x .118
70	585 33 88-01	Bracket Deck Susp. Front
75	580 68 37-01	Pinion
76	580 68 36-01	Screw Head Sock
122	532 44 49-62	Cap Gear

NOTE: All component dimensions given in U.S. inches
1 inch = 25.4 mm

TRACTOR - MODEL NO. YTH18K46 (96043023200), PRODUCT NO. 960 43 02-32
MOWER DECK

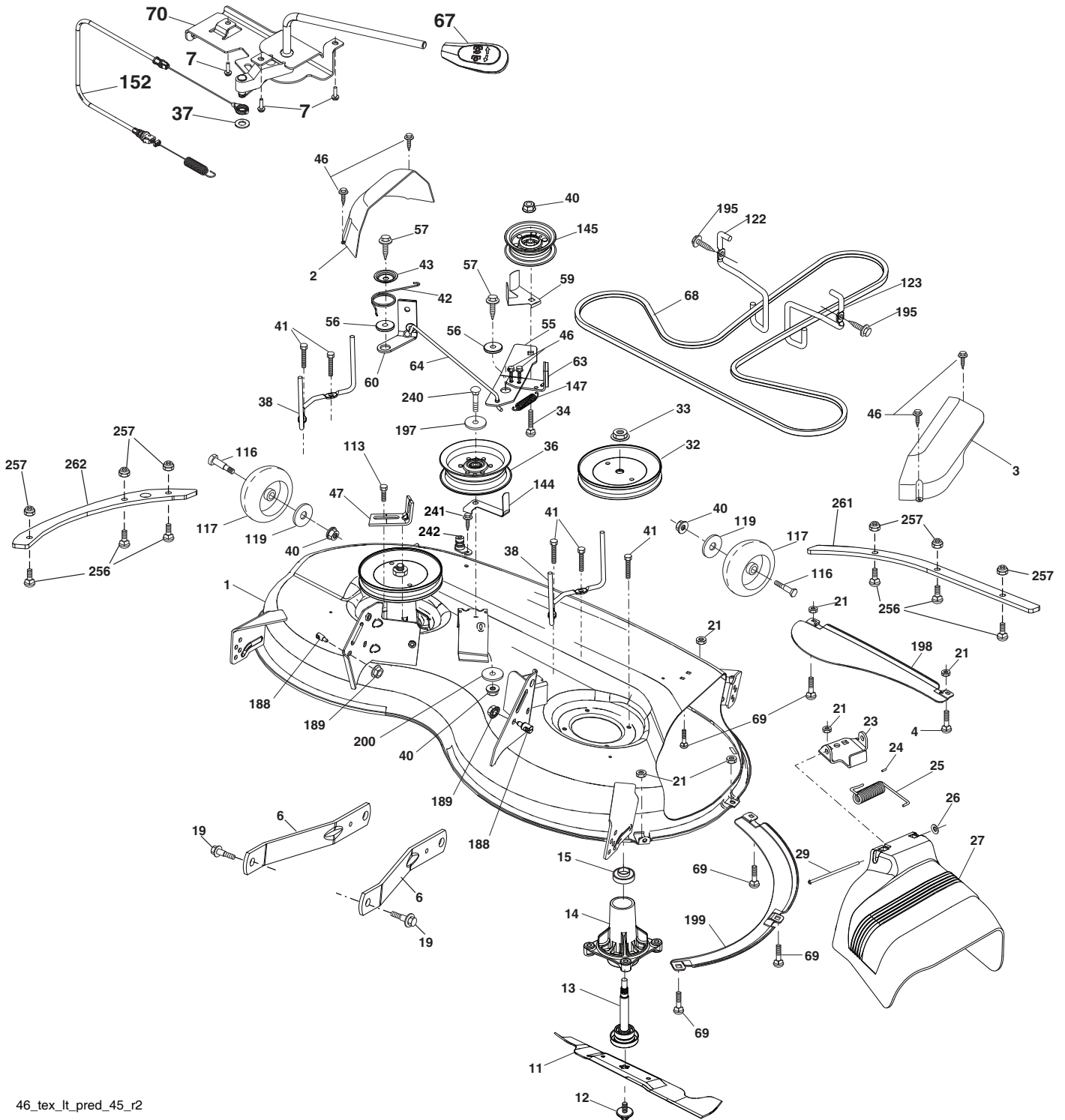

46_tex_lt_pred_45_r2

**TRACTOR - MODEL NO. YTH18K46 (96043023200), PRODUCT NO. 960 43 02-32
MOWER DECK**

KEY NO.	PART NO.	DESCRIPTION	KEY NO.	PART NO.	DESCRIPTION
1	589 53 53-03	Mower Housing	67	532 40 30-12	Handle, Clutch Cable
2	532 40 55-07	Cover Mandrel LH	68	532 40 51-43	V-Belt
3	532 40 55-06	Cover Mandrel RH	69	872 14 05-05	Bolt
4	874 76 05-12	Bolt Hex Hd 5/16-18 unc	70	532 19 99-72	Clutch Asm. Cable
6	532 19 51-86	Arm Suspension	113	817 00 05-10	Screw 5/16-18
7	532 41 63-58	Screw # 10 x 0.750	116	532 19 34-06	Bolt, Shoulder
11	532 40 53-80	Blade Mower Hi Lift	117	532 17 48-73	Wheel, Gauge
12	584 30 93-01	Screw Sems 7/16-20 x 1 Hx Hd	119	819 13 20-12	Washer 13/32 x 1-1/4 x 12 Ga.
13	587 25 65-01	Shaft Assembly, Mandrel	122	532 19 72-58	Keeper Belt Eng. LH
14	532 18 72-81	Housing, Mandrel	123	532 19 72-59	Keeper Belt Eng. RH
15	585 32 39-01	Bearing, Ball, Mandrel	144	532 19 92-04	Keeper Belt
19	532 19 65-39	Bolt, Shoulder	145	532 19 31-97	Pulley Idler
21	873 68 05-00	Nut Crownlock 5/16-18	147	532 40 18-72	Spring Return
23	532 19 25-57	Bracket, Deflector	152	584 24 35-01	Cable Clutch Manual w/Spr.
24	532 10 53-04	Cap, Sleeve	188	532 19 51-61	Stud Fastener
25	532 19 70-26	Spring, Torsion, Deflector	189	873 90 05-00	Nut Lock Hex Flange
26	532 11 04-52	Nut, Push	195	817 00 06-12	Screw 3/8-16 x 3/4
27	532 40 53-57	Shield, Deflector	197	819 13 13-12	Washer 13/32 x 13/16 x 12 Ga.
29	532 13 14-91	Rod, Hinge	198	532 40 31-49	Baffle Center Front
32	532 19 74-73	Pulley, Mandrel	199	532 40 31-50	Baffle Front RH
33	532 40 02-34	Nut, Toplock, Flanged	200	532 41 35-24	Washer 13/32 x 1 x 1/2 11 Ga.
34	872 11 06-12	Bolt Carr Sh. 3/8-16 x 1-1/2 Gr. 5	240	874 52 06-36	Bolt 3/8-16 unc x 2-1/4 Gr. 5
36	532 19 73-79	Pulley, Idler, Flat	241	532 15 29-27	Screw
37	819 13 13-16	Washer 13/32 x 13/16 x 16 Ga.	242	532 41 55-98	Washout Port
38	532 43 25-20	Keeper Belt LH Mandrel	256	539 10 98-00	Carriage Bolt 1/4-20 x 1 Gr. 5
40	873 90 06-00	Nut, Lock Flg. 3/8-16 unc	257	873 90 04-00	Nut Hex Flng 1/4-20 unc
41	584 95 39-01	Bolt Hex Washer hd. 3/16-18 x 1.19	261	589 48 18-05	Plate Reinforcement Front
42	532 19 84-10	Spring Torsion Brake	262	589 48 20-05	Plate Reinforcement Side
43	532 19 72-56	Spring Torsion Retainer	--	532 41 64-05	Quick Connect Coupling
46	532 13 77-29	Screw	--	587 25 33-01	Mandrel Assembly (Includes housing (Key#14), shaft assembly (Key#13), and bearing only (Key#15) - pulley/nut/washer and blade bolt/washers not included)
47	532 19 72-50	Bracket Clutch Cable			
55	532 19 72-49	Arm, Idler			
56	532 19 90-92	Spacer, Retainer			
57	817 00 06-16	Screw Hexwsh Thd 3/8-16 x 1			
59	532 14 10-43	Guard, Tuv Idler (94)	--	586 05 90-01	Replacement Mower, Complete
60	532 19 94-71	Arm Brake Mower LH			
63	532 19 94-77	Arm Brake Mower			
64	532 40 51-38	Linkage Brake			

NOTE: All component dimensions given in U.S. inches
1 inch = 25.4 mm

**TRACTOR - MODEL NO. YTH18K46 (96043023200), PRODUCT NO. 960 43 02-32
MOWER LIFT**

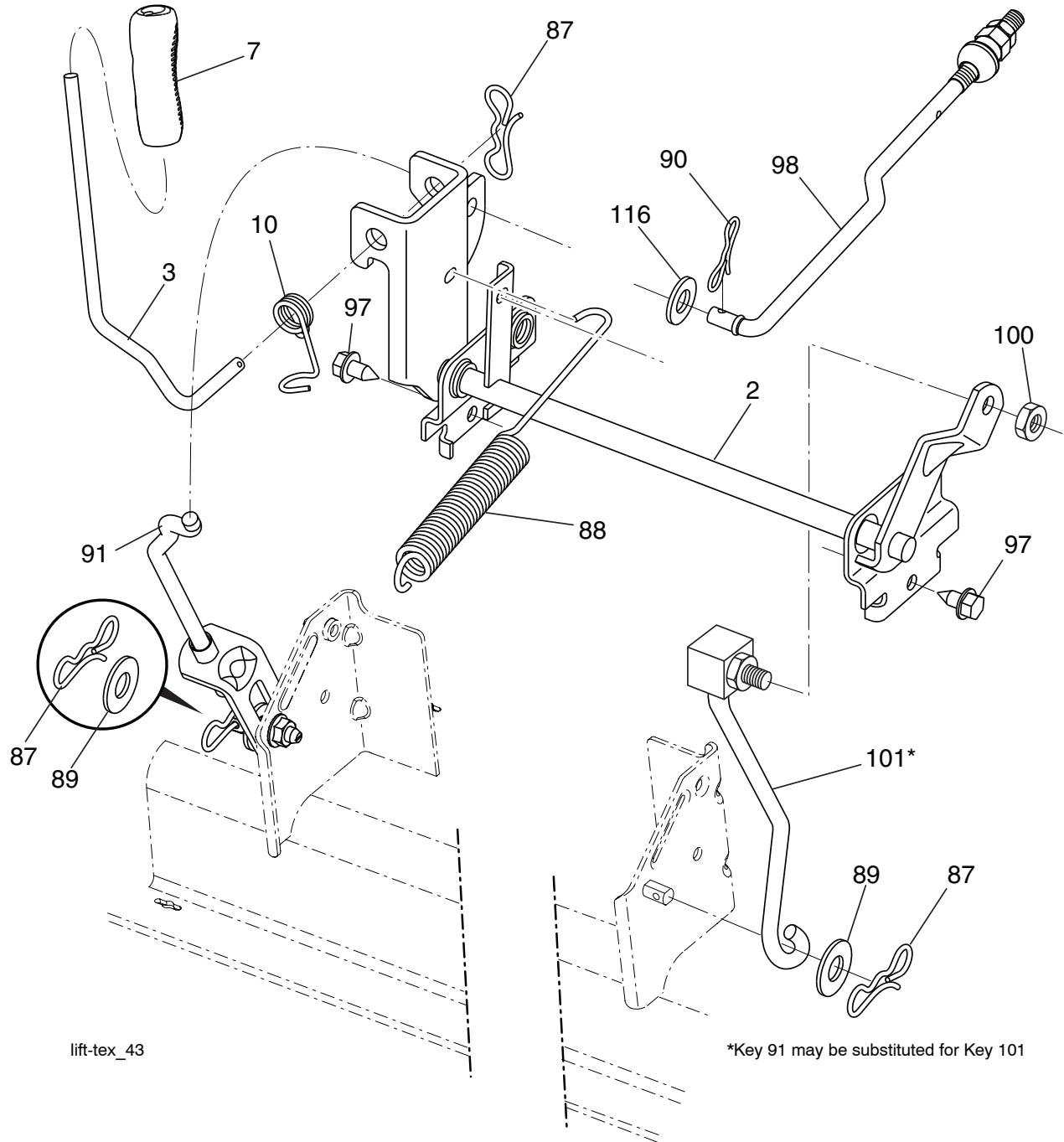

lift-tex_43

*Key 91 may be substituted for Key 101

KEY NO.	PART NO.	DESCRIPTION
2	532 42 20-27	Shaft Asm., Lift
3	532 19 52-31	Lever Asm., Lift RH
7	580 96 23-01	Grip, Lever
10	532 19 63-14	Spring Torsion
87	532 19 42-09	Pin Cotter 7/16 Bow Tie Lock
88	532 41 07-10	Spring Lift Assist
89	819 19 19-12	Washer Clear Zinc
90	532 19 42-08	Pin Cotter 5/16 Bow Tie Lock
91	532 19 51-81	Link Lift Susp Mower Rear

KEY NO.	PART NO.	DESCRIPTION
97	817 00 06-12	Screw 3/8-16 x .75 Smgml Tap/R.Z
98	532 19 52-70	Link Lift Susp. Front Mower
100	873 93 06-00	Nut Center Lock 3/8-16 unc
101	532 40 70-03	Link Asm Lift Fixed
116	819 15 15-16	Washer 15/32 x 15/16 x 16 Ga.

NOTE: All component dimensions given in U.S. inches
1 inch = 25.4 mm

TRACTOR - MODEL NO. YTH18K46 (96043023200), PRODUCT NO. 960 43 02-32 SEAT ASSEMBLY

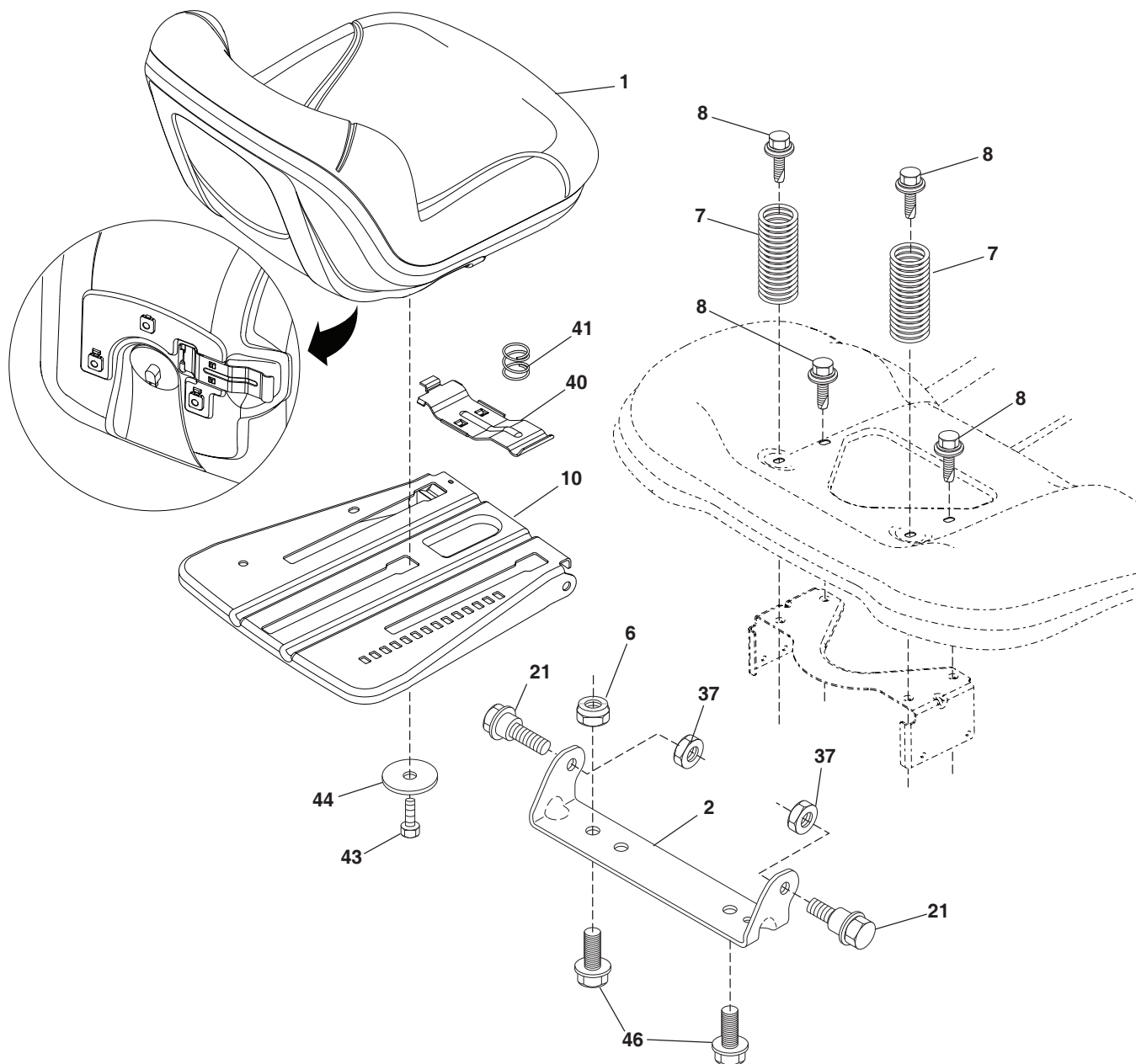

seat-tex_6.5SL_9

KEY NO.	PART NO.	DESCRIPTION
1	532 43 98-22	Seat
2	532 18 01-66	Bracket Pivot Fender
6	873 80 06-00	Nut, Lock W/Ins. 3/8-16 unc
7	587 61 33-01	Spring, Seat Cprsn
8	532 17 18-77	Bolt 5/16-18 unc x 3/4 w/Sems
10	532 19 69-77	Pan, Seat
21	587 90 78-01	Bolt, Shoulder 5/16-18 x 5/8
37	873 80 05-00	Nut, Lock 5/16-18 unc

KEY NO.	PART NO.	DESCRIPTION
40	532 19 76-61	Handle Slide Seat
41	532 19 82-00	Spring Latch Seat
43	874 76 06-12	Bolt 3/8-16 x 3/4
44	819 13 38-12	Washer 13/32 x 2-3/8 x 12 Ga.
46	588 09 04-01	Bolt 3/8-16 x 1, 1 25 OD

NOTE: All component dimensions given in U.S. inches
1 inch = 25.4 mm

**TRACTOR - MODEL NO. YTH18K46 (96043023200), PRODUCT NO. 960 43 02-32
DECALS**

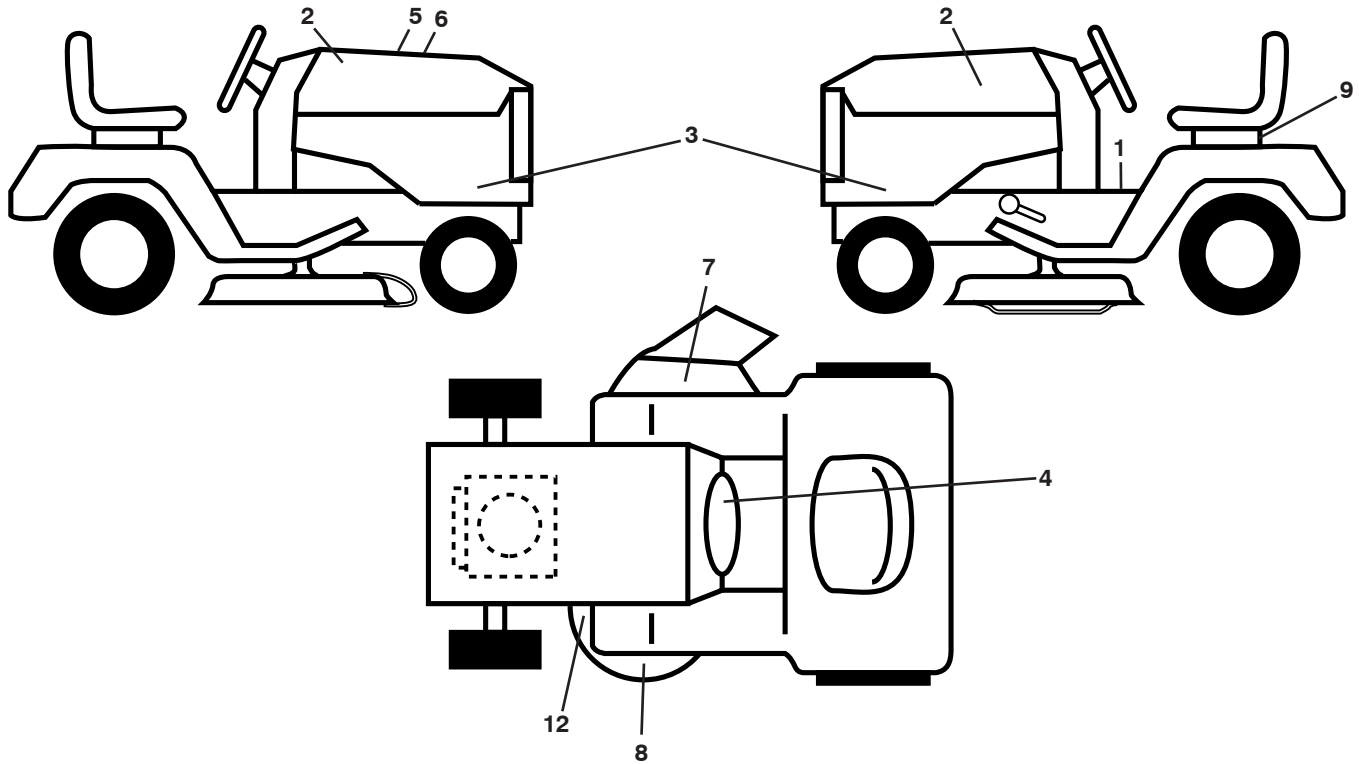

KEY NO.	PART NO.	DESCRIPTION	KEY NO.	PART NO.	DESCRIPTION
1	581 57 89-01	Decal, Fender Warning	12	581 58 00-01	Decal, Mower V-Belt Schematic
2	581 62 73-01	Decal, Hood	--	581 72 48-01	Decal, Bypass
3	581 51 04-01	Decal, Hood Panel SD	--	532 43 96-81	Pad, Footrest, LH
4	532 42 41-02	Decal, Warning Spark	--	532 43 96-82	Pad, Footrest, RH
5	532 42 38-29	Decal, Customer Respons.	--	115 86 29-26	Manual Operator's (English/Spanish)
6	579 67 86-01	Decal, Replacement	--	115 86 30-26	Manual Part's (English/Spanish)
7	584 90 46-01	Decal, Deflect. Warning	--	587 71 00-26	Quick Start Guide (English/Spanish)
8	585 71 44-01	Decal Pop Armored			
9	532 14 50-05	Decal, Battery Dnge/Poi			

WHEELS AND TIRES

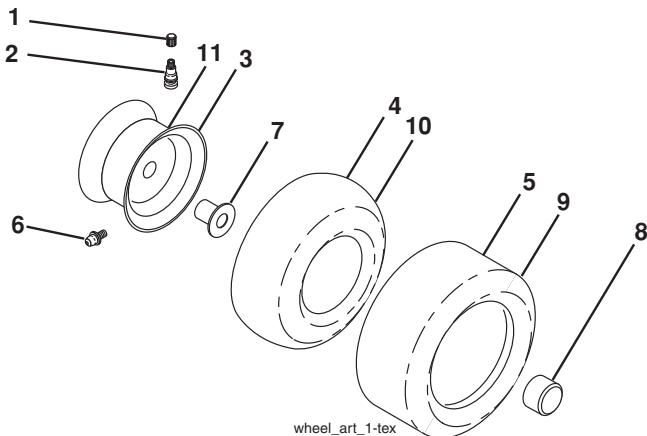

KEY NO.	PART NO.	DESCRIPTION
1	532 05 91-92	Cap Valve Tire
2	532 06 51-39	Stem Valve
3	532 13 83-36	Rim Front
4	532 05 99-04	Tube Front (Service Item Only)
5	532 10 62-22	Tire Front 15 x 6-6
6	532 12 49-57	Fitting Grease (Front Wheel Only)
7	532 12 49-59	Bearing Flange (Front Wheel Only)
8	532 17 50-39	Cap Axle Blk 1 50 x 1 00
9	532 13 84-68	Tire Rear 20 x 8-8
10	532 12 49-26	Tube Rear (Service Item Only)
11	532 13 83-37	Rim Asm 8" Rear
--	532 14 43-34	Sealant, Tire (10 oz. Tube)

NOTE: All component dimensions given in U.S. inches
1 inch = 25.4 mm

TRACTOR - MODELO NO. YTH18K46 (96043023200), PRODUCTO NO. 960 43 02-32 DIAGRAMA

SCH10-s

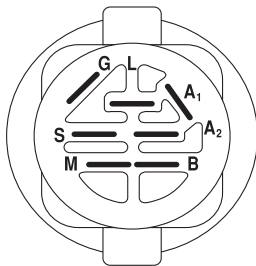
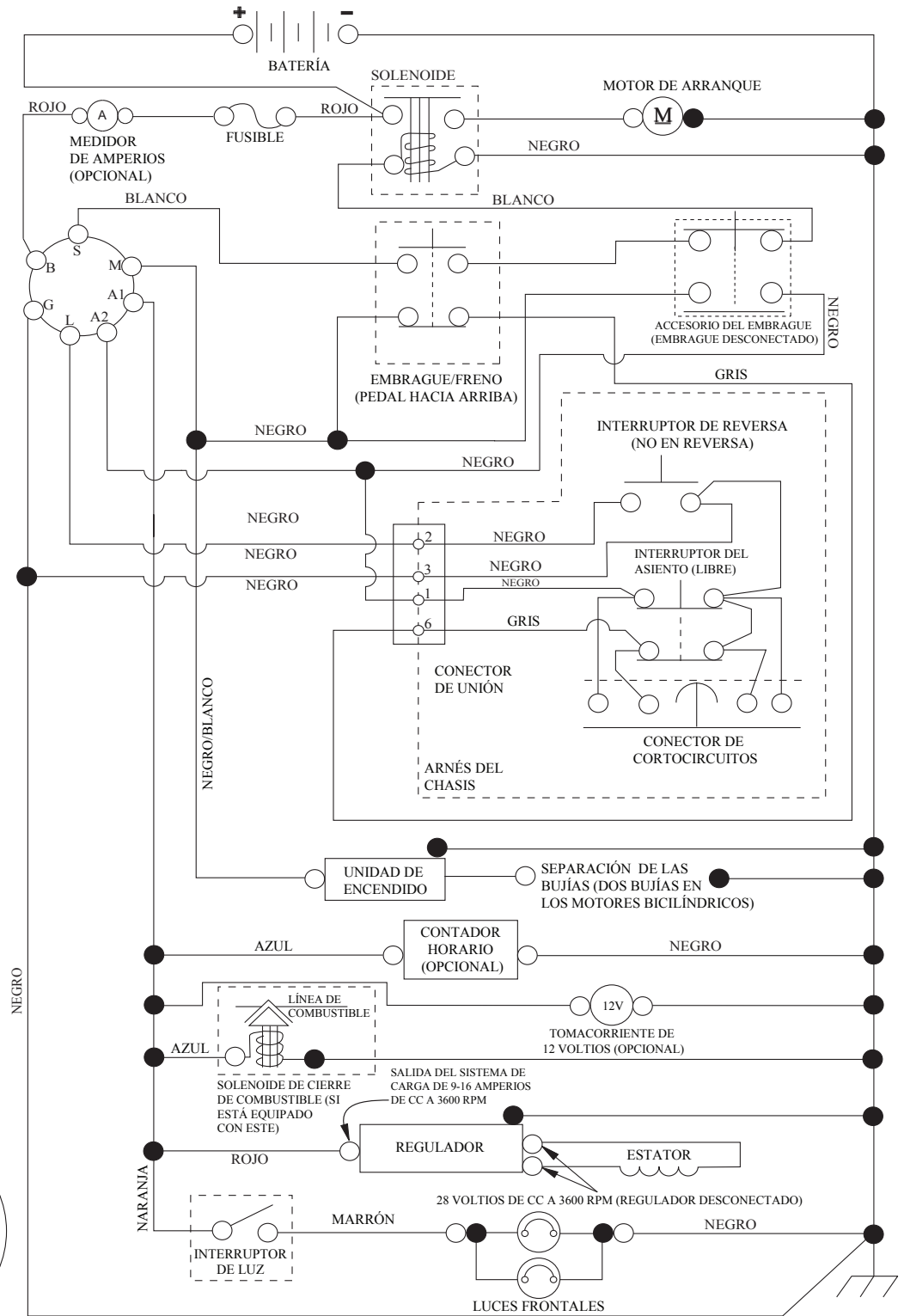

INTERRUPTOR DE ENCENDIDO

POSICIÓN	CIRCUITO «MARCA»
APAGADO	M+G+A1
PONER EN FUNCIONAMIENTO/ANULAR	B+A1
PONER EN FUNCIONAMIENTO	B+A1 L+A2
ARRANCAR	B + S + A1

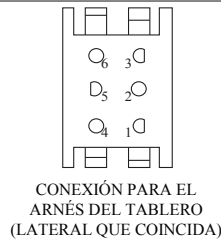

NOTA SOBRE LAS ABRAZADERAS DE AISLAMIENTO DEL CABLEADO: SI SE QUITAN LAS ABRAZADERAS DE AISLAMIENTO DEL CABLEADO PARA HACER EL MANTENIMIENTO DE LA UNIDAD, SE LAS DEBERÁ INSTALAR NUEVAMENTE PARA PROTEGER EL CABLEADO ADECUADAMENTE.



TRACTOR - MODELO NO. YTH18K46 (96043023200), PRODUCTO NO. 960 43 02-32
DIAGRAMA ELÉCTRICO

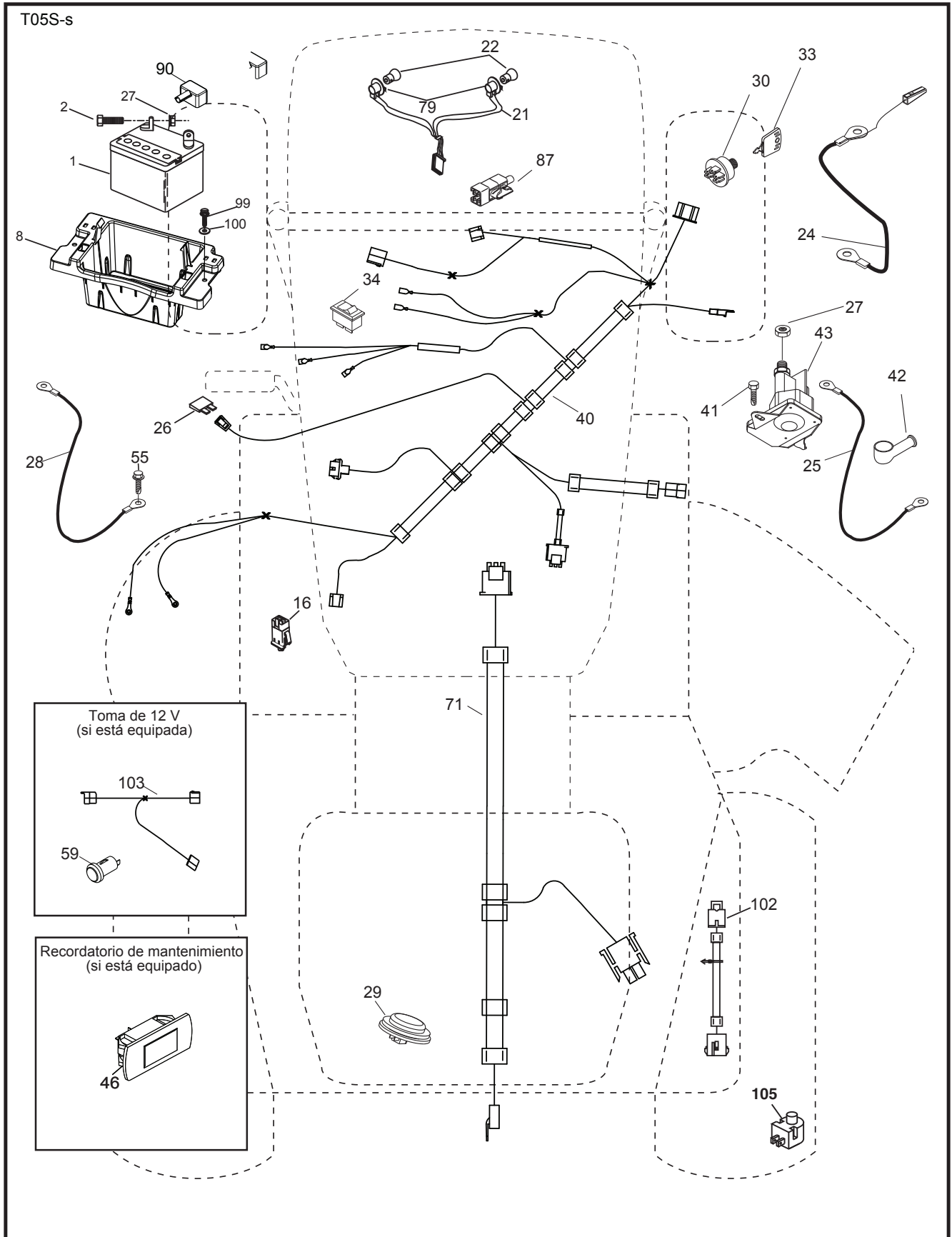

**TRACTOR - MODELO NO. YTH18K46 (96043023200), PRODUCTO NO. 960 43 02-32
DIAGRAMA ELÉCTRICO**

CÓDIGO PIEZA		DESCRIPCIÓN
No.	No.	
1	532 16 34-65	Batería
2	874 76 04-12	Perno de cabeza hexagonal de 1/4-20 x 3/4
8	532 41 41-26	Caja de la batería
16	532 17 61-38	Interruptor corta corriente a presión
21	532 40 02-52	Cableado del enchufe para la luz c/4152J
22	532 00 41-52	Bombilla de luz
24	585 55 56-01	Cable
25	585 55 55-01	Cable
26	532 17 51-58	Fusible
27	873 51 04-00	Tuerca hexagonal Keps de 1/4-20 unc
28	532 41 65-88	Cable a tierra
29	532 40 15-45	Interruptor del asiento
30	532 19 33-50	Interruptor de encendido
33	532 41 19-33	Llave/cadena
34	532 11 07-12	Interruptor de luz/de restauración
40	501 13 30-01	Relé de arnés de encendido eléctrico
41	817 72 04-08	Tornillo 1/4-20 x 1/2
42	532 13 15-63	Cubierta
43	582 04 28-01	Solenoide
46	586 16 18-01	Indicador SRVCMNDR HRMTR
55	817 06 05-12	Tornillo de 5/16-18 x 3/4
71	532 19 42-76	Cableado de encendido Chasis
79	532 17 52-42	Enchufe de cierre por torsión del ensamble de la bombilla
87	532 19 78-02	Interruptor
90	532 43 53-95	Tapa de los bornes de la batería
99	817 67 04-12	Tornillo 1/4-20 x 3/4
100	819 09 14-16	Washer 9/32 x 7/8 x calibre 16
102	532 40 44-54	Cableado
105	532 40 75-68	Interruptor

NOTA: Las dimensiones de todos los componentes están expresadas en pulgadas americanas. 1 pulgada = 25,4 mm

TRACTOR - MODELO NO. YTH18K46 (96043023200), PRODUCTO NO. 960 43 02-32
CHASIS

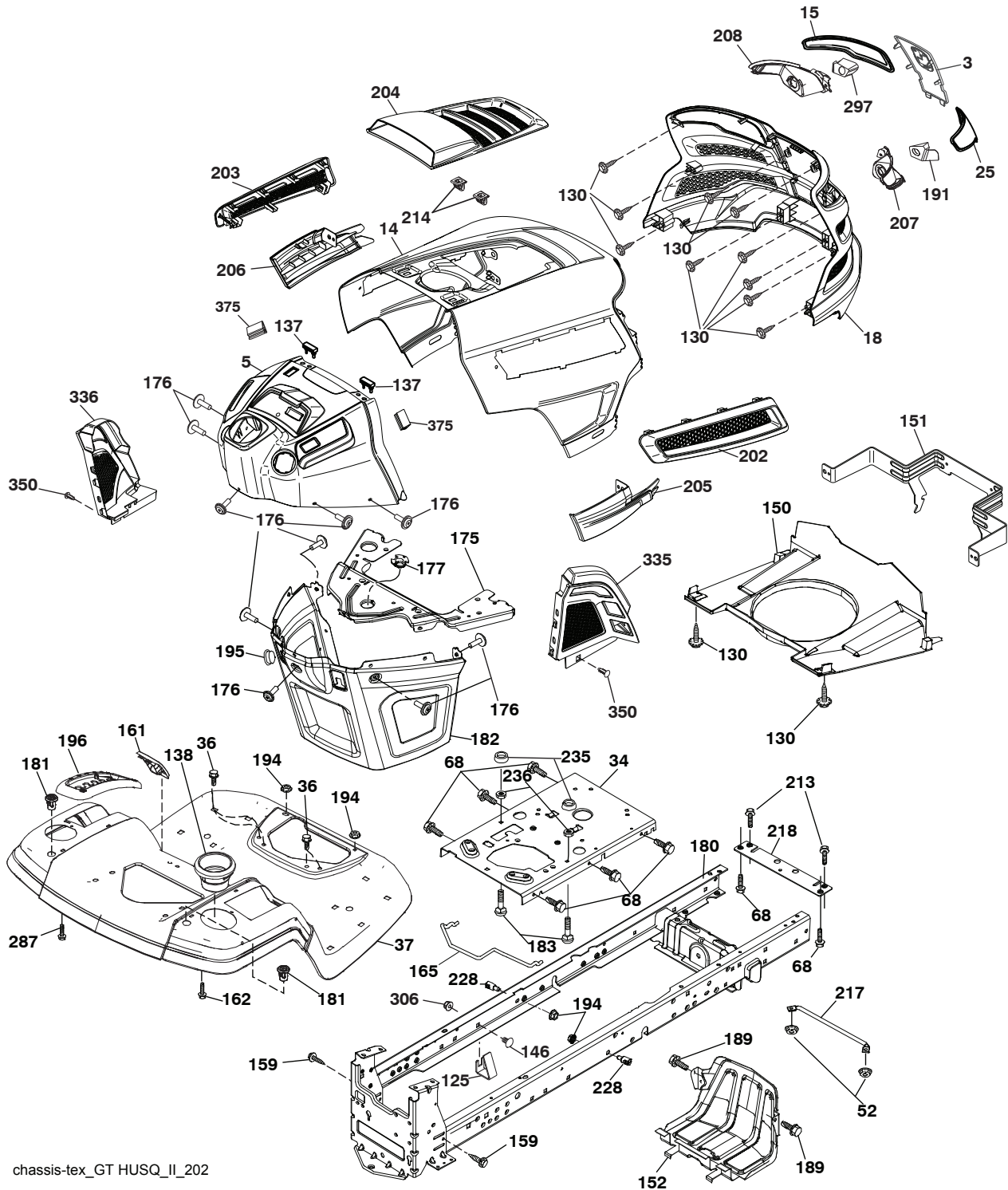

chassis-tex_GT HUSQ_II_202

TRACTOR - MODELO NO. YTH18K46 (96043023200), PRODUCTO NO. 960 43 02-32 CHASIS

CÓDIGO PIEZA			CÓDIGO PIEZA		
No.	No.	DESCRIPCIÓN	No.	No.	DESCRIPCIÓN
3	532 44 44-81	Aplica Submontaje	189	817 00 05-12	Tornillo 5/16-18 x 3/4
5	589 34 34-01	Tablero	191	532 43 74-55	Inserto LD
14	532 44 11-77	Capota	194	873 90 05-00	Tuerca de presión de 5/16-18
15	532 43 97-33	Lente izquierdo de la parrilla	195	532 40 41-37	Tapón
18	532 44 06-53	Parrilla	196	532 43 96-47	Ensamble de la consola de la plataforma de elevación
25	532 44 33-85	Lente derecho de la parrilla	202	532 43 97-28	Salida de Ventilación (LD)
34	580 91 08-01	Chapa Motor	203	532 43 97-27	Salida de Ventilación (LI)
36	817 06 05-12	Tornillo de 5/16-18 x 3/4	204	532 44 44-84	Salida de Ventilación superior
37	532 44 12-69	Guardabarros	205	532 43 97-30	Camisa de Capota (LD)
52	873 68 05-00	Tuerca de presión 5/16-18	206	532 43 97-29	Camisa de Capota (LI)
68	817 49 05-08	Tornillo de 5/16-18 x 1/2	207	532 43 97-34	Bisel derecho
125	581 68 48-01	Soporte	208	532 43 97-35	Bisel izquierdo
130	532 41 63-58	Tornillo No. 10 x 0,75	213	874 76 05-12	Perno
137	532 40 75-90	Cubierta Tablero	214	532 19 91-45	Cierre
138	532 43 97-47	Portavasos	217	532 40 91-67	Varilla giratoria
146	581 85 79-01	Perno	218	532 19 63-95	Tope
150	532 43 97-31	Cubierta térmica del conducto	228	532 19 51-61	Sujetador del travesaño
151	532 43 66-70	Soporte	235	532 40 61-29	Separador del guardabarros
152	532 43 98-70	Protector contra oscurecimiento	236	873 93 05-00	Tuerca de presión 5/16-18 unc
159	817 00 06-12	Tornillo 3/8-16 x 3/4	287	817 60 04-06	Tornillo 1/4 - 20 x 3/8
161	532 43 97-81	Ventana de combustible	297	532 43 74-56	Inserto LI
162	532 14 24-32	Tornillo	306	873 90 06-00	Tuerca
165	532 19 68-26	Soporte	335	532 44 82-04	Cubierta LD
175	532 19 63-04	Travesaño	336	532 44 53-09	Cubierta LI
176	532 40 07-76	Tornillo de 10-24 x 5/8	337	532 44 51-43	Cierre del árbol de navidad
177	532 19 52-28	Buje de dirección	375	586 90 82-01	Parachoques
180	532 19 54-57	Chasis			
181	532 43 97-46	Buje de soporte del guardabarros de carga			
182	532 40 68-59	Tablero inferior			
183	874 52 05-20	Perno 5/16-18 x 1-1/4			

NOTA: Las dimensiones de todos los componentes están expresadas en pulgadas americanas. 1 pulgada = 25,4 mm

TRACTOR - MODELO NO. YTH18K46 (96043023200), PRODUCTO NO. 960 43 02-32
TRANSMISIÓN

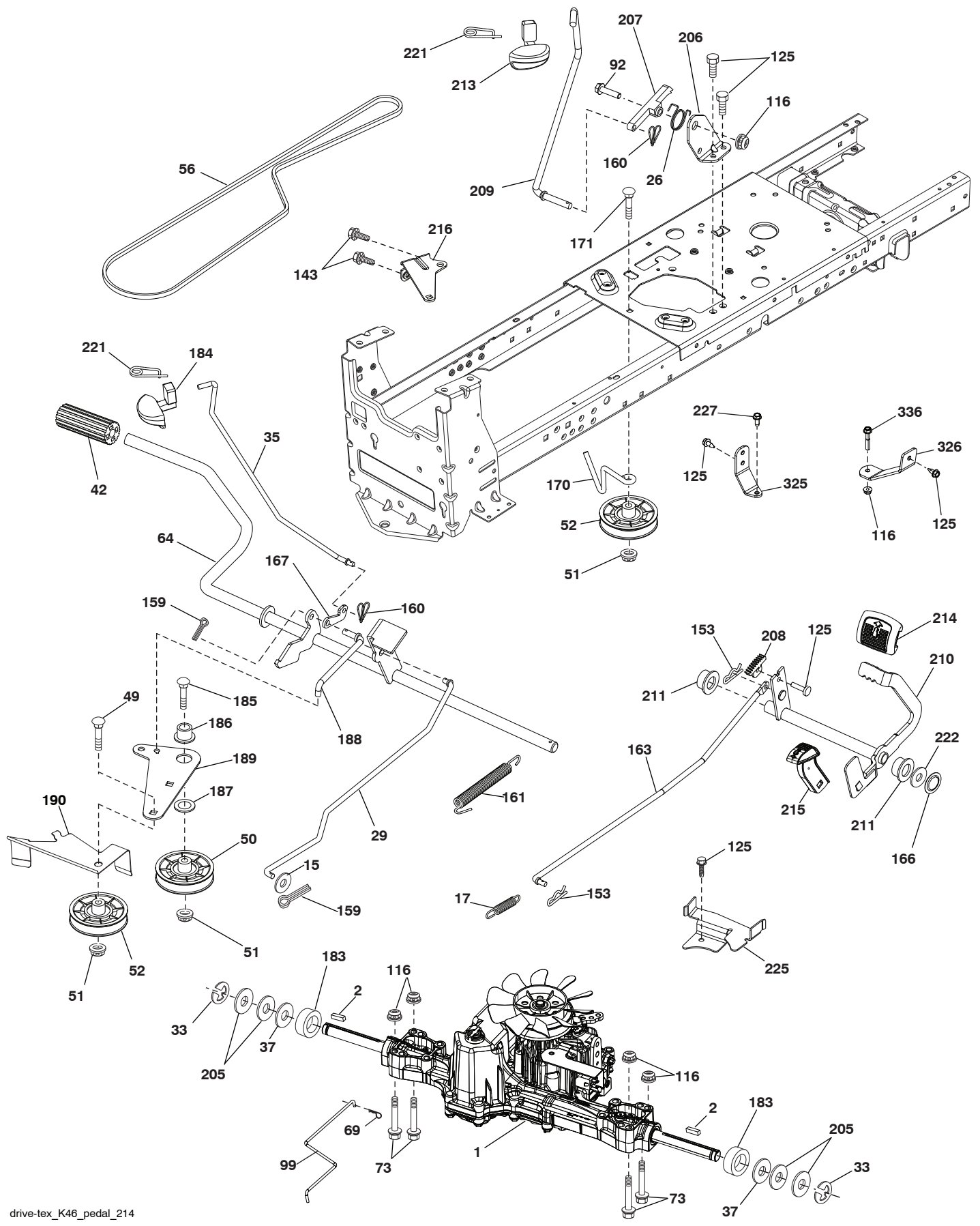

drive-tex_K46_pedal_214

TRACTOR - MODELO NO. YTH18K46 (96043023200), PRODUCTO NO. 960 43 02-32 TRANSMISIÓN

CÓDIGO No.	PIEZA No.	DESCRIPCIÓN	CÓDIGO No.	PIEZA No.	DESCRIPCIÓN
1	---	Transeje, TUFFTORQ K46BT (426120) (Haga el pedido de las piezas al fabricante del transeje.)	171	872 11 06-16	Perno
2	532 12 35-83	Cuña	183	532 13 70-57	Separador del eje
15	819 13 13-16	Arandela de 13/32 x 13/16 x calibre 16	184	587 65 37-01	Manija del freno de mano
17	532 41 36-78	Resorte de freno	185	872 11 06-22	Perno
26	532 19 96-79	Crucero con retorno de muelle	186	532 19 43-21	Espaciador de retención
29	532 40 38-06	Varilla del freno	187	819 13 32-10	Arandela
33	812 00 00-01	Aro E	188	582 21 70-01	Mecanismo de desplazamiento de la varilla de mando del embrague del largo
35	583 86 45-01	Varilla del freno de mano	189	532 19 43-17	Palanca acodada del mecanismo de desplazamiento
37	532 18 89-67	Arandela	190	532 19 43-18	Sujetador de la palanca acodada del mecanismo de desplazamiento
42	532 12 48-72	Cubierta del pedal	205	532 12 17-48	Arandela de 25/32 x 1-5/8 calibre 16
49	872 11 06-14	Perno	206	532 44 85-96	Soporte de montaje del bloqueo del crucero
50	532 19 43-27	Polea loca plana	207	587 03 14-01	Bloqueo del control del crucero
51	873 90 06-00	Tuerca de presión de 3/8-16	208	532 19 78-69	Engranaje del sector de control del crucero
52	532 19 43-26	Polea loca con ranura en V con un desplazamiento	209	532 19 95-92	Varilla de control del crucero
56	532 13 09-69	Correa trapezoidal de la transmisión	210	532 40 09-80	Ensamble del control del pedal
64	532 19 78-65	Ensamble del eje Control del pedal de freno	211	532 12 01-83	Rodamiento de nylon
69	532 42 33-03	Clavija	213	532 40 31-19	Perilla de control del crucero
73	874 49 05-40	Perno de 5/16-18 x 2 1/2 G.5	214	532 42 12-63	Forro del pedal para avanzar
92	874 76 05-20	Perno de cabeza hexagonal con aleta de 5/16-18 unc x 1,25	215	586 60 65-02	Forro del pedal para retroceder
99	582 40 45-01	Varilla del ensamble con resorte de desviación	216	532 19 61-31	Soporte del Polea
116	873 90 05-00	Tuerca de presión hexagonal con brida de 5/16-18	221	532 40 31-87	Abrazadera de retención del resorte de la manija
125	817 00 05-12	Tornillo de 5/16-18 x 3/4	222	879 21 20-10	Arandela de 21/32 x 1-1/4 calibre 10
143	817 49 05-08	Tornillo de 5/16-18 x 1/2	225	532 40 33-19	Sujetador de la correa
153	532 12 47-88	Retén del resorte	227	817 49 05-12	Tornillo
159	876 02 04-12	Pasador de chaveta de 1/8 x 3/4	325	585 66 85-02	Soporte
160	532 16 94-84	Abrazadera de retención	326	585 67 08-02	Soporte
161	532 10 57-09	Resorte de retorno del embrague	336	587 25 96-01	Perno 5/16 - 18 x 1-3/4
163	532 44 82-75	Varilla de control			
166	532 42 91-64	Tuerca de presión			
167	532 40 52-57	Pestillo del freno de mano			
170	532 19 43-22	Sujetador de la correa			

NOTA: Las dimensiones de todos los componentes están expresadas en pulgadas americanas. 1 pulgada = 25,4 mm

**TRACTOR - MODELO NO. YTH18K46 (96043023200), PRODUCTO NO. 960 43 02-32
MOTOR**

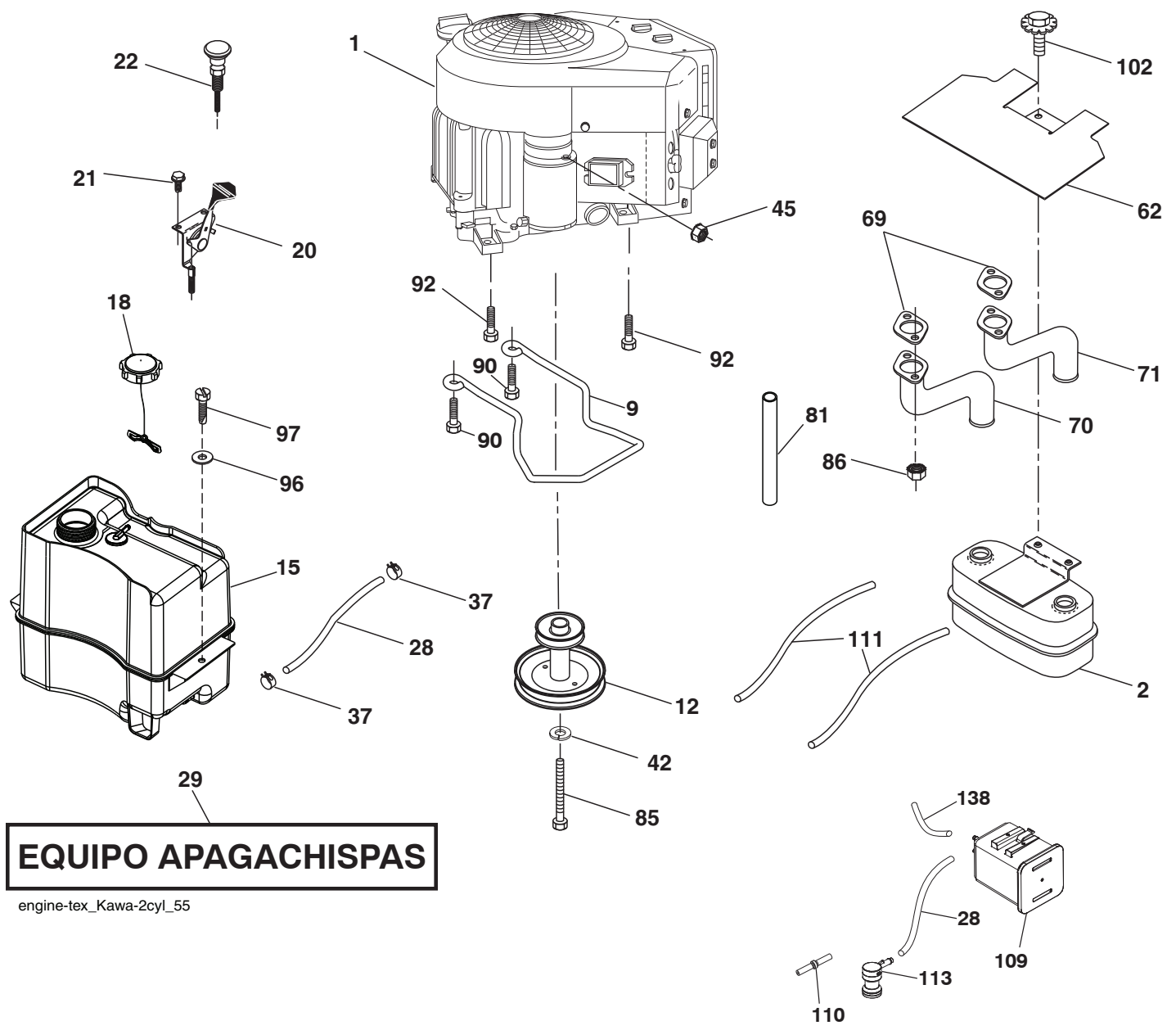

EQUIPO APAGACHISPAS

engine-tex_Kawa-2cyl_55

TRACTOR - MODELO NO. YTH18K46 (96043023200), PRODUCTO NO. 960 43 02-32 MOTOR

CÓDIGO No.	PIEZA No.	DESCRIPCIÓN
1	-----	Motor Kawa modelo No. FR600V-AS11 (581477001) (Haga el pedido de las piezas al fabricante del motor.)
2	589 81 87-01	Silenciador
9	501 83 26-02	Ensamble del sujetador de la correa del motor
12	586 72 89-01	Polea del motor
15	539 90 05-01	Tanque de combustible
18	585 12 48-01	Ensamble de la tapa
20	532 41 21-65	Control del regulador
21	532 41 63-58	Tornillo No. 10 x 0,75
22	532 18 95-41	Control del obturador
28	532 40 11-35	Línea de combustible
29	532 13 71-80	Equipo apagachispas
37	532 12 34-87	Abrazadera de la manguera
42	810 04 07-00	Arandela de presión de 7/16
45	873 51 04-00	Tuerca
62	532 43 40-17	Silenciador con pantalla térmica
69	532 17 81-51	Junta
70	583 95 57-01	Tubo de escape derecho
71	583 95 56-01	Tubo de escape izquierdo
81	532 14 84-56	Tubo
85	501 60 65-01	Perno de 7/16-20 x 4 grado 5-1.5
86	532 18 43-62	Contratuerca hexagonal de seguridad de M8-1.25
90	817 00 06-16	Tornillo 3/8-16 x 1
92	817 12 06-16	Tornillo 3/8-16 x 1
96	819 09 14-16	Arandela de 9/32 x 7/8 x calibre 16
97	817 67 04-12	Tornillo 1/4-20 x 3/4
102	817 00 05-12	Tornillo 5/16-18 x 3/4
109	532 41 41-14	Bote
110	532 41 41-18	Válvula
111	532 41 41-19	Línea de purga 3/16
113	532 41 41-27	Válvula
138	532 42 07-18	Ligne De Purge

NOTA: Las dimensiones de todos los componentes están expresadas en pulgadas americanas. 1 pulgada = 25,4 mm

Para realizar el mantenimiento del motor y para obtener repuestos, llame al número gratuito del fabricante de su motor que se enumera a continuación:

Kawasaki 1-949-460-5688

TRACTOR - MODELO NO. YTH18K46 (96043023200), PRODUCTO NO. 960 43 02-32
ENSAMBLE DE LA DIRECCIÓN

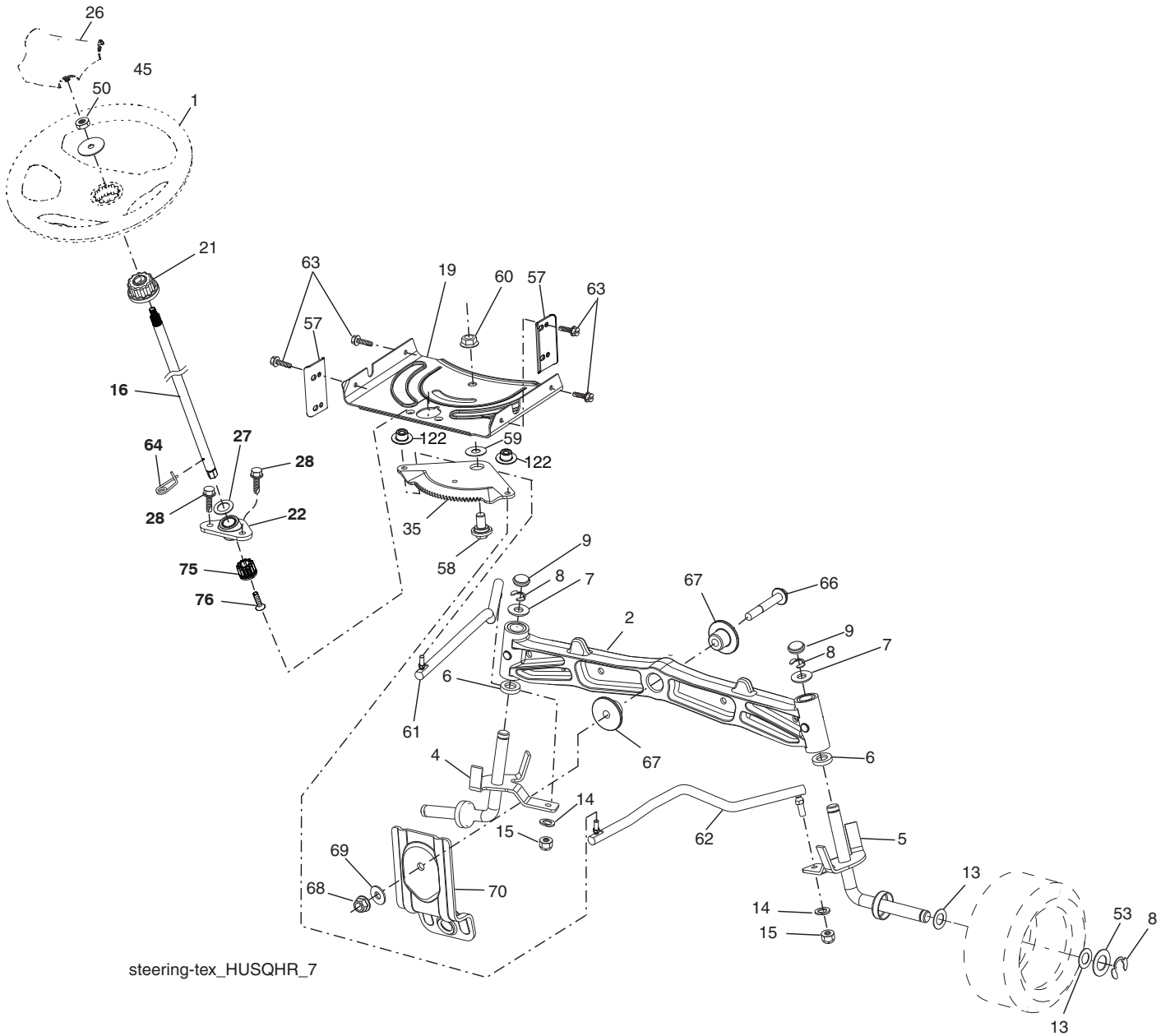

steering-tex_HUSQHR_7

**TRACTOR - MODELO NO. YTH18K46 (96043023200), PRODUCTO NO. 960 43 02-32
ENSAMBLE DE LA DIRECCIÓN**

CÓDIGO No.	PIEZA No.	DESCRIPCIÓN
1	532 43 97-40	Volante de dirección
2	532 19 59-68	Eje
4	532 40 30-87	Ensamble del husillo izquierdo
5	532 40 30-88	Ensamble del husillo derecho
6	532 12 49-31	Arandela
7	532 12 17-48	Arandela de 25/32 x 1-5/8 calibre 16
8	812 00 00-29	Abrazadera del aro No. T5304-75
9	532 12 12-32	Tapa del husillo
13	532 12 17-49	Arandela de 25/32 x 1-1/4 calibre 16
14	810 04 06-00	Arandela de presión de 3/8
15	873 54 06-00	Tuerca corona de presión de 3/8-24 unf
16	587 01 60-02	Eje de dirección
19	532 19 47-29	Placa de dirección
21	586 84 02-01	Adaptador del volante de dirección
22	585 02 98-02	Rodamiento
26	532 43 97-43	Inserto del volante de dirección
27	819 21 16-16	Arandela
28	817 00 06-12	Tornillo de 3/8-16 x 3/4
35	532 19 47-32	Engranaje del sector de la placa
45	587 01 64-01	Arandela 3/8 ID 2-3/8 OD calibre 12 PLTD
50	873 90 06-00	Tuerca 3/8-16 unc
53	532 18 89-67	Arandela reforzada de 793 x 1637 x 0,060
57	532 40 74-65	Tope superior del soporte
58	532 19 47-47	Perno de tope del sector del pivote CFM
59	532 19 47-48	Arandela de empuje del sector de dirección
60	873 97 10-00	Tuerca de presión con brida de 5/8-11
61	532 19 47-40	Barra de acoplamiento izquierda
62	532 19 47-41	Barra de acoplamiento derecha
63	817 00 05-12	Tornillo de 5/16-18 x 3/4
64	532 19 98-49	Abrazadera de retención del resorte de la dirección
66	871 02 07-48	Perno de cabeza 7/16-14 x 3
67	532 19 47-37	Buje PM del eje delantero
68	873 90 07-00	Tuerca de presión con brida de 7/16-14 grado 5
69	532 19 91-62	Arandela de 1,5 x 0,505 x 0,118
70	585 33 88-01	Soporte de la plataforma delantera
75	580 68 37-01	Piñón
76	580 68 36-01	Tornillo
122	532 44 49-62	Tapa

NOTA: Las dimensiones de todos los componentes están expresadas en pulgadas americanas. 1 pulgada = 25,4 mm

TRACTOR - MODELO NO. YTH18K46 (96043023200), PRODUCTO NO. 960 43 02-32
PLATAFORMA DE LA CORTADORA DE CÉSPED

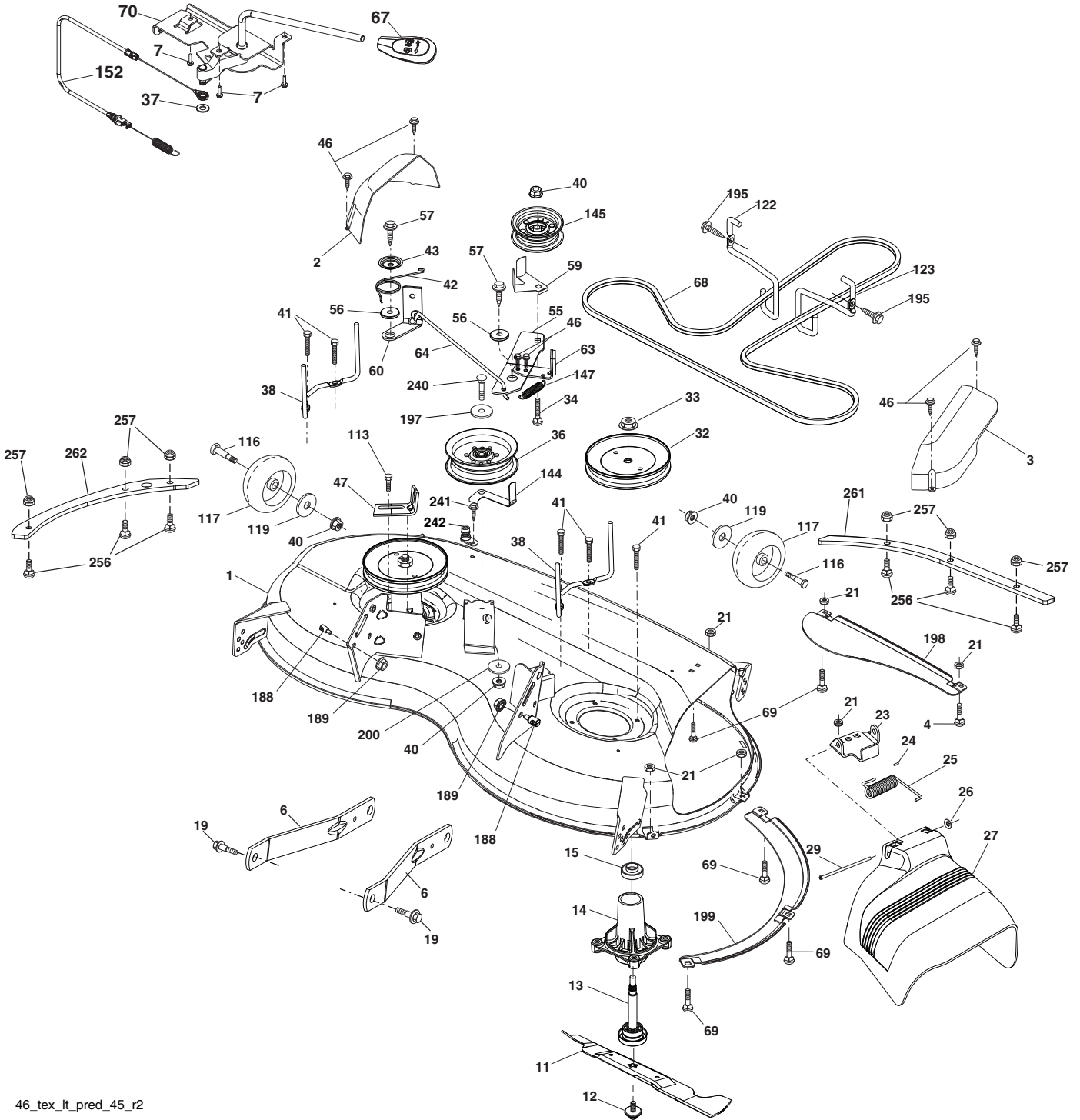

46_tex_lt_pred_45_r2

TRACTOR - MODELO NO. YTH18K46 (96043023200), PRODUCTO NO. 960 43 02-32 PLATAFORMA DE LA CORTADORA DE CÉSPED

CÓDIGO PIEZA		DESCRIPCIÓN	CÓDIGO PIEZA		DESCRIPCIÓN
No.	No.		No.	No.	
1	589 53 53-03	Carcasa de la cortadora de césped	67	532 40 30-12	Manija del cable de embrague
2	532 40 55-07	Cubierta izquierda del mandril	68	532 40 51-43	Correa trapezoidal
3	532 40 55-06	Cubierta derecha del mandril	69	872 14 05-05	Perno
4	874 76 05-12	Perno 5/16-18 unc	70	532 19 99-72	Ensamble del embrague Manual
6	532 19 51-86	Brazo de la suspensión	113	817 00 05-10	Tornillo de 5/16-18
7	532 41 63-58	Tornillo No. 10 x 0,750	116	532 19 34-06	Perno de tope
11	532 40 53-80	Cuchilla de la cortadora	117	532 17 48-73	Calibrador de la rueda
12	584 30 93-01	Tornillo 7/16-20 x 1	119	819 13 20-12	Arandela de 13/32 x 1-1/4 x calibre 12
13	587 25 65-01	Ensamble del eje del mandril	122	532 19 72-58	Sujetador izquierdo de la correa del motor
14	532 18 72-81	Carcasa del mandril			
15	585 32 39-01	Rodamiento de bolas del mandril	123	532 19 72-59	Sujetador derecho de la correa del motor
19	532 19 65-39	Perno de tope	144	532 19 92-04	Sujetador de la correa
21	873 68 05-00	Tuerca 5/16-18	145	532 19 31-97	Polea loca
23	532 19 25-57	Soporte del deflector	147	532 40 18-72	Retorno del resorte
24	532 10 53-04	Tapa de la manga	152	584 24 35-01	Cable de embrague manual con resorte
25	532 19 70-26	Resorte de torsión del deflector	188	532 19 51-61	Sujetador del travesaño
26	532 11 04-52	Tuerca de presión	189	873 90 05-00	Tuerca de presión hexagonal con brida
27	532 40 53-57	Protector del deflector	195	817 00 06-12	Tornillo de 3/8-16 x 3/4
29	532 13 14-91	Varilla de la bisagra	197	819 13 13-12	Arandela de 13/32 x 13/16 x calibre 12
32	532 19 74-73	Polea del mandril	198	532 40 31-49	Deflector delantero central
33	532 40 02-34	Tuerca de seguridad con brida	199	532 40 31-50	Deflector delantero derecho
34	872 11 06-12	Perno de 3/8-16 x 1-1/2 grado 5	200	532 41 35-24	Arandela de 13/32 x 1 x 1/2 calibre 11
36	532 19 73-79	Polea loca	240	874 52 06-36	Perno 3/8-16 unc x 2-1/4
37	819 13 13-16	Arandela de 13/32 x 13/16 x calibre 16	241	532 15 29-27	Tornillo
38	532 43 25-20	Sujetador de la correa izquierda del mandril	242	532 41 55-98	Puerto de Lavado de la Cubierta
			256	539 10 98-00	Perno de acarreo, m 1/4-20 x 1 Gr. 5
40	873 90 06-00	Tuerca de presión con brida de 3/8-16 unc	257	873 90 04-00	Tuerca 1/4-20 unc
41	584 95 39-01	Perno 3/8-16 x 1.19	261	589 48 18-05	Plaque de reinforcement delantero
42	532 19 84-10	Resorte de torsión del freno	262	589 48 20-05	Plaque de reinforcement lado
43	532 19 72-56	Resorte de torsión de retención	--	532 41 64-05	Enganche
46	532 13 77-29	Tornillo	--	587 25 33-01	Ensamble del Mandril (solo incluye la carcasa (#14), el ensamble del eje (#13) y el rodamiento (#15); no incluye la polea/tuerca/arandela ni los pernos/arandelas de la cuchilla)
47	532 19 72-50	Soporte del cable de embrague	--	586 05 90-01	Reemplazo de la cortadora de césped, completa
55	532 19 72-49	Brazo de la polea			
56	532 19 90-92	Espaciador de retención			
57	817 00 06-16	Tornillo hexagonal con arandela de 3/8-16 x 1			
59	532 14 10-43	Dispositivo de protección de la polea (94)			
60	532 19 94-71	Brazo izquierdo del freno de la cortadora de césped			
63	532 19 94-77	Brazo del freno de la cortadora de césped			
64	532 40 51-38	Varillaje del freno			

NOTA: Las dimensiones de todos los componentes están expresadas en pulgadas americanas. 1 pulgada = 25,4 mm

TRACTOR - MODELO NO. YTH18K46 (96043023200), PRODUCTO NO. 960 43 02-32
ELEVACIÓN DE LA CORTADORA DE CÉSPED

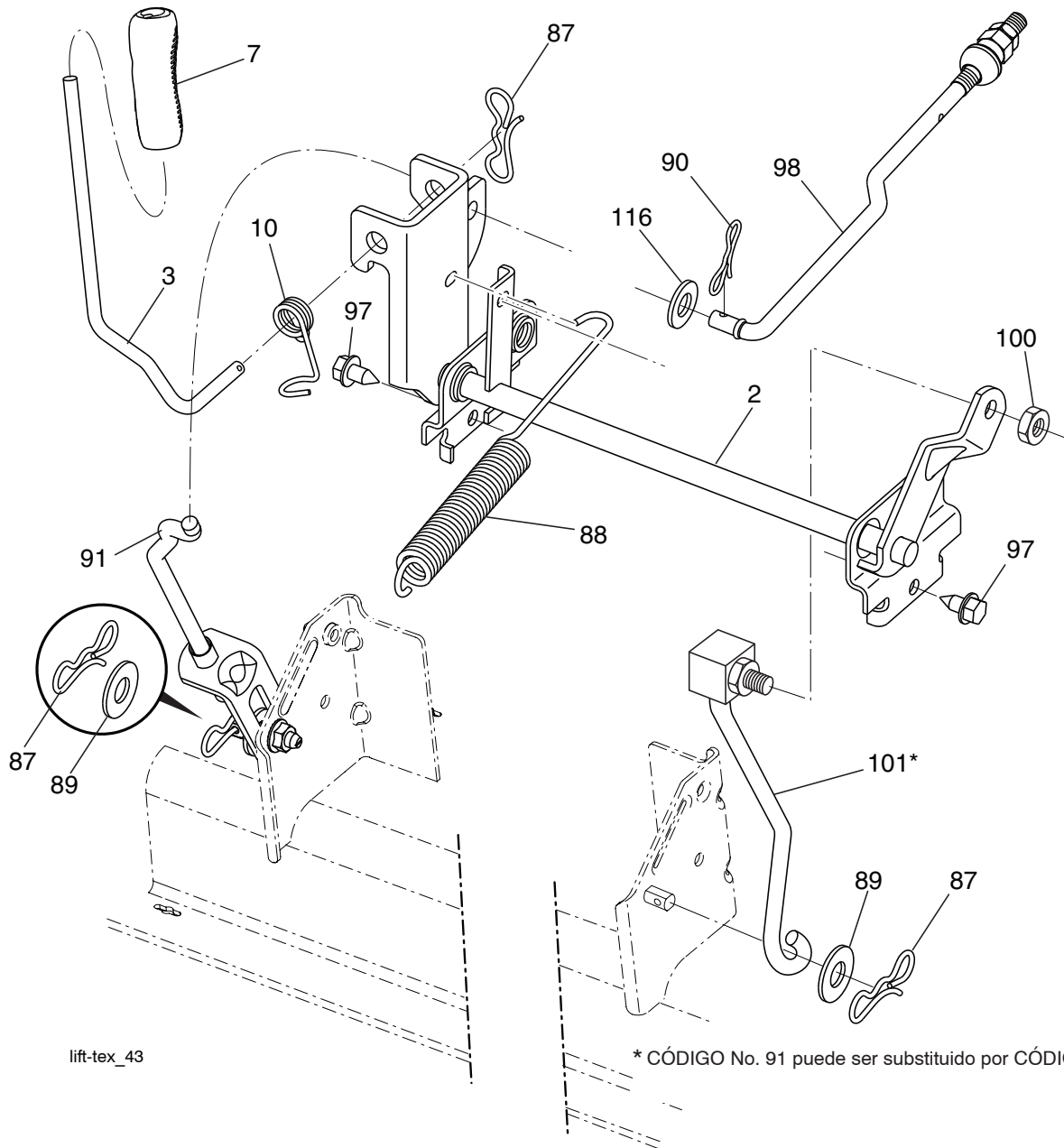

lift_tex_43

* CÓDIGO No. 91 puede ser substituido por CÓDIGO No. 101

CÓDIGO No.	PIEZA No.	DESCRIPCIÓN
2	532 42 20-27	Ensamble del eje de la elevación
3	532 19 52-31	Ensamble de la palanca de elevación derecha
7	580 96 23-01	Mango de la palanca
10	532 19 63-14	Resorte de torsión
87	532 19 42-09	Pasador de chaveta de 7/16 con bloqueo en forma de mariposa
88	532 41 07-10	Resorte de ayuda de la elevación
89	819 19 19-12	Arandela de zinc transparente
90	532 19 42-08	Pasador de chaveta de 5/16 con bloqueo en forma de mariposa

CÓDIGO No.	PIEZA No.	DESCRIPCIÓN
91	532 19 51-81	Ensamble del acoplamiento
97	817 00 06-12	Tornillo de 3/8-16 x 0,75
98	532 19 52-70	Acoplamiento frontal de la elevación de la cortadora de césped
100	873 93 06-00	Tuerca de 3/8-16 unc
101	532 40 70-03	Ensamble del acoplamiento elevación
116	819 15 15-16	Arandela 15/32 x 15/16 x calibre16

NOTA: Las dimensiones de todos los componentes están expresadas en pulgadas americanas. 1 pulgada = 25,4 mm

TRACTOR - MODELO NO. YTH18K46 (96043023200), PRODUCTO NO. 960 43 02-32 ENSAMBLE DEL ASIENTO

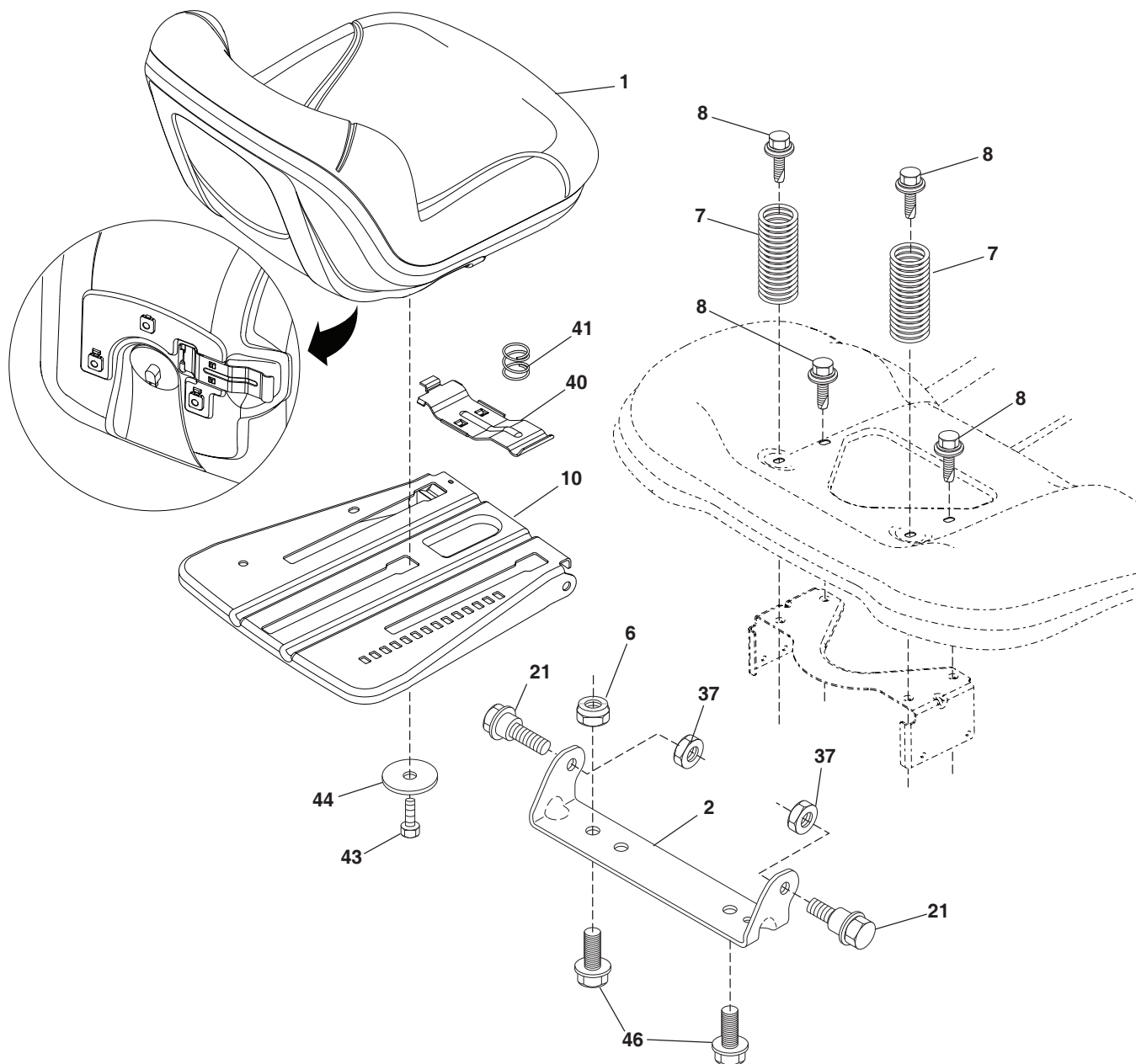

seat-tex_6.5SL_9

CÓDIGO No.	PIEZA No.	DESCRIPCIÓN
1	532 43 98-22	Asiento
2	532 18 01-66	Soporte pivotante del guardabarros
6	873 80 06-00	Tuerca de presión c/aislamiento de 3/8-16 unc
7	587 61 33-01	Resorte del asiento
8	532 17 18-77	Perno 5/16-18 unc x 3/4
10	532 19 69-77	Bandeja del asiento
21	587 90 78-01	Perno 5/16-18 x 5/8
37	873 80 05-00	Tuerca 5/16-18 unc

CÓDIGO No.	PIEZA No.	DESCRIPCIÓN
40	532 19 76-61	Manija para deslizar el asiento
41	532 19 82-00	Resorte para trabar el asiento
43	874 76 06-12	Perno 3/8-16 x 3/4
44	819 13 38-12	Arandela 13/32 x 2-3/8 x calibre 12
46	588 09 04-01	Perno 3/8-16 x 1, 1 25

NOTA: Las dimensiones de todos los componentes están expresadas en pulgadas americanas. 1 pulgada = 25,4 mm

**TRACTOR - MODELO NO. YTH18K46 (96043023200), PRODUCTO NO. 960 43 02-32
CALCOMANÍAS**

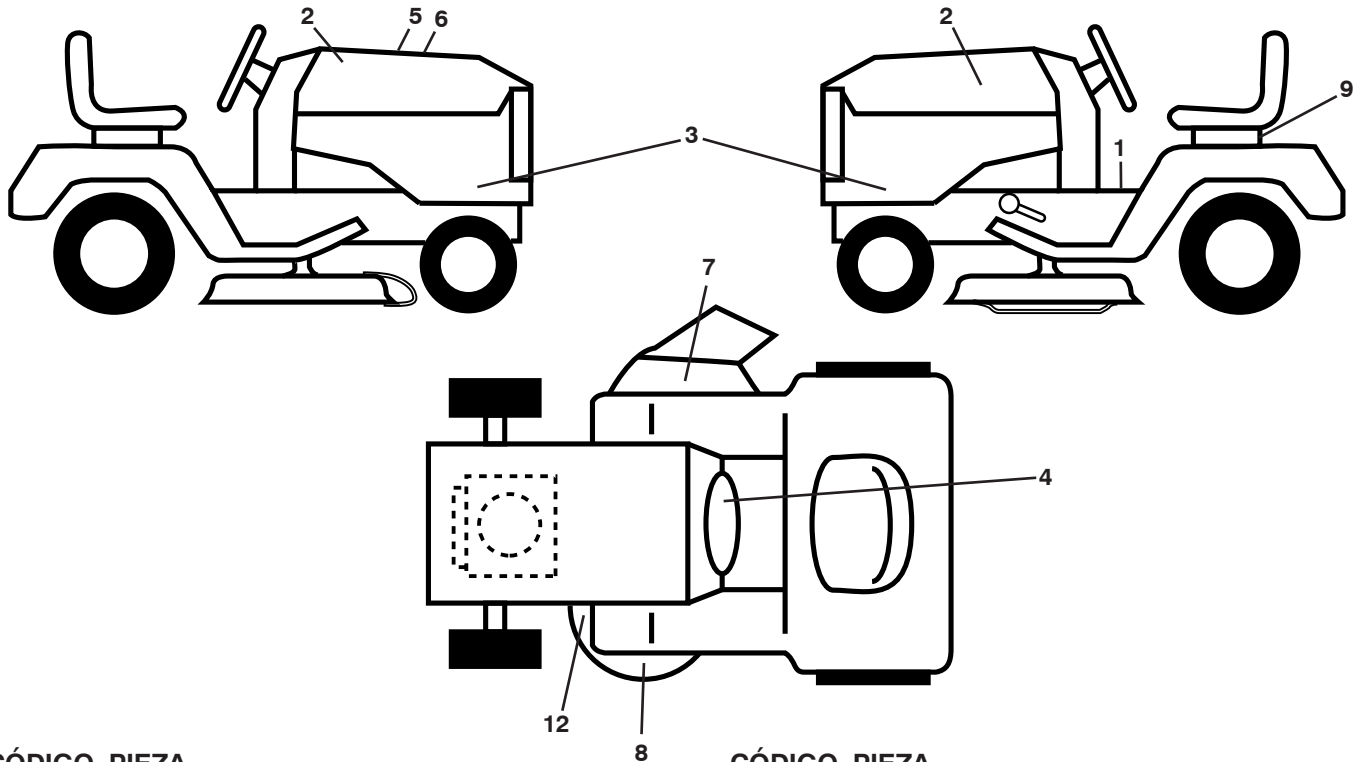

CÓDIGO No.	PIEZA No.	DESCRIPCIÓN
1	581 57 89-01	Calcomanía para el guardabarros
2	581 62 73-01	Calcomanía para la capota
3	581 51 04-01	Calcomanía para el panel capota
4	532 42 41-02	Calcomanía
5	532 42 38-29	Calcomanía del operador
6	579 67 86-01	Calcomanía de reemplazo
7	584 90 46-01	Calcomanía
8	585 71 44-01	Calcomanía
9	532 14 50-05	Calcomanía de Peligro/Punto de interconexión

CÓDIGO No.	PIEZA No.	DESCRIPCIÓN
12	581 58 00-01	Calcomanía del diagrama de la cortadora de césped
--	581 72 48-01	Calcomanía para la desviación
--	532 43 96-81	Forro del apoyo para los pies (LI)
--	532 43 96-82	Forro del apoyo para los pies (LD)
--	115 86 29-26	Manual del Operario (Inglés/Español)
--	115 86 30-26	Manual de Repuestos (Inglés/Español)
--	587 71 00-26	Guía rápida (Inglés/Español)

RUEDAS Y NEUMÁTICOS

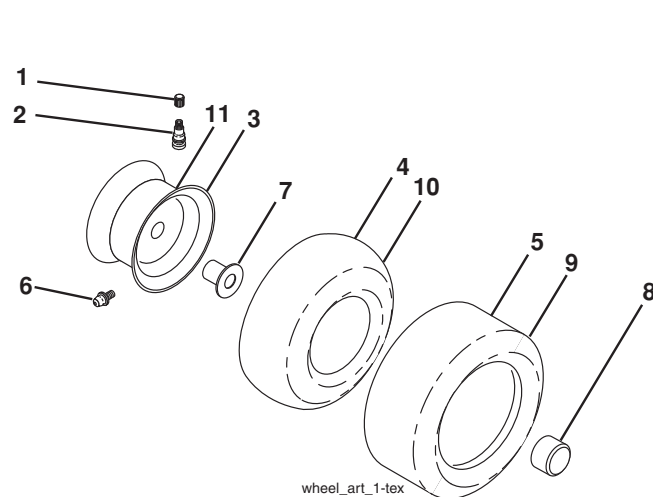

CÓDIGO No.	PIEZA No.	DESCRIPCIÓN
1	532 05 91-92	Tapa de la válvula del neumático
2	532 06 51-39	Vástago de la válvula
3	532 13 83-36	Ensamble de las llantas delanteras
4	532 05 99-04	Cámara delantera (Mantenimiento sólo)
5	532 10 62-22	Neumático delantero 15 x 6-6
6	532 12 49-57	Accesorio para engrasar (solo para la rueda delantera)
7	532 12 49-59	Rodamiento de la brida (solo para la rueda delantera)
8	532 17 50-39	Tapa del eje 1 50 x 1 00
9	532 13 84-68	Neumático 20 x 8-8
10	532 12 49-26	Cámara trasera (Mantenimiento sólo)
11	532 13 83-37	Ensamble trasero de la llanta 8"
--	532 14 43-34	Sellador para neumáticos (tubo de 10 onzas [283 gr])

NOTA: Las dimensiones de todos los componentes están expresadas en pulgadas americanas. 1 pulgada = 25,4 mm

SERVICE NOTES/AVISO



www.husqvarna.com