

Repair Parts Manual
Manual De Repuestos
YTH1942 / 96043026700

Please read the operator's manual carefully and make sure you understand the instructions before using the machine.

Por favor lea cuidadosamente y comprenda estas instrucciones antes de usar esta maquina.



English/Spanish

115 94 98-49 Rev. 8



HOW TO USE THIS MANUAL

This manual is designed to provide the customer with a means to identify the parts on his/her tractor when ordering repair parts. The illustrations may or may not represent the actual assemblies; therefore, it is not recommended to use this manual as a guide to assemble or disassemble the tractor. Some hardware and parts are drawn larger in order to more readily identify them.

Each tractor has its own model number. The model number for your tractor can be found on the fender under the seat.

Support / Help

If you require assistance or have questions concerning the application, operation, maintenance or parts for your product:

- Visit our website: www.husqvarna.com
- Call Us Toll Free: 1-800-487-5951

When ordering parts, always give the following information:

- Product - "TRACTOR"
- MODEL NUMBER - "YTH1942" (96043026700)"
- Part Number
- Part Description

TABLE OF CONTENTS

SCHEMATIC	3
ELECTRICAL	4-5
CHASSIS	6-7
DRIVE	8-9
ENGINE	10-11
STEERING	12-13
MOWER DECK	14-15
MOWER LIFT	16
SEAT	17
DECALS	18

COMO UTILIZAR ESTE MANUAL

Este manual está diseñado para brindarle al comprador un medio para identificar las piezas del tractor para cuando necesite hacer el pedido de un repuesto. Las ilustraciones pueden o no representar los ensambles reales; por lo tanto, no se recomienda utilizar este manual como una guía para ensamblar o desarmar el tractor. Algunos accesorios y piezas están dibujados en tamaños más grandes para identificarlos con mayor facilidad.

Cada tractor tiene su propio número de modelo. El número de modelo del tractor se encuentra en el guardabarros debajo del asiento.

Soporte / Ayuda

Si necesita asistencia o tiene alguna pregunta acerca de la aplicación, operación, mantenimiento o piezas de su producto:

- Visite nuestro sitio web: www.husqvarna.com
- Llámenos de manera gratuita al: 1-800-487-5951

Cuando haga el pedido de una pieza, siempre brinde la siguiente información:

- Producto: "TRACTOR"
- NÚMERO DE MODELO: "YTH1942" (96043026700)"
- Número de pieza
- Descripción de la pieza

ÍNDICE

DIAGRAMA	19
DIAGRAMA ELÉCTRICO	20-21
CHASIS	22-23
TRANSMISIÓN	24-25
MOTOR	26-27
DIRECCIÓN	28-29
PLATAFORMA DE LA CORTADORA DE CÉSPED	30-31
ELEVACIÓN DE LA CORTADORA DE CÉSPED	32
ASIENTO	33
CALCOMANÍAS	34

TRACTOR - - MODEL NUMBER YTH1942 (96043026700), PRODUCT NO. 960 43 02-67 SCHEMATIC

SCH10

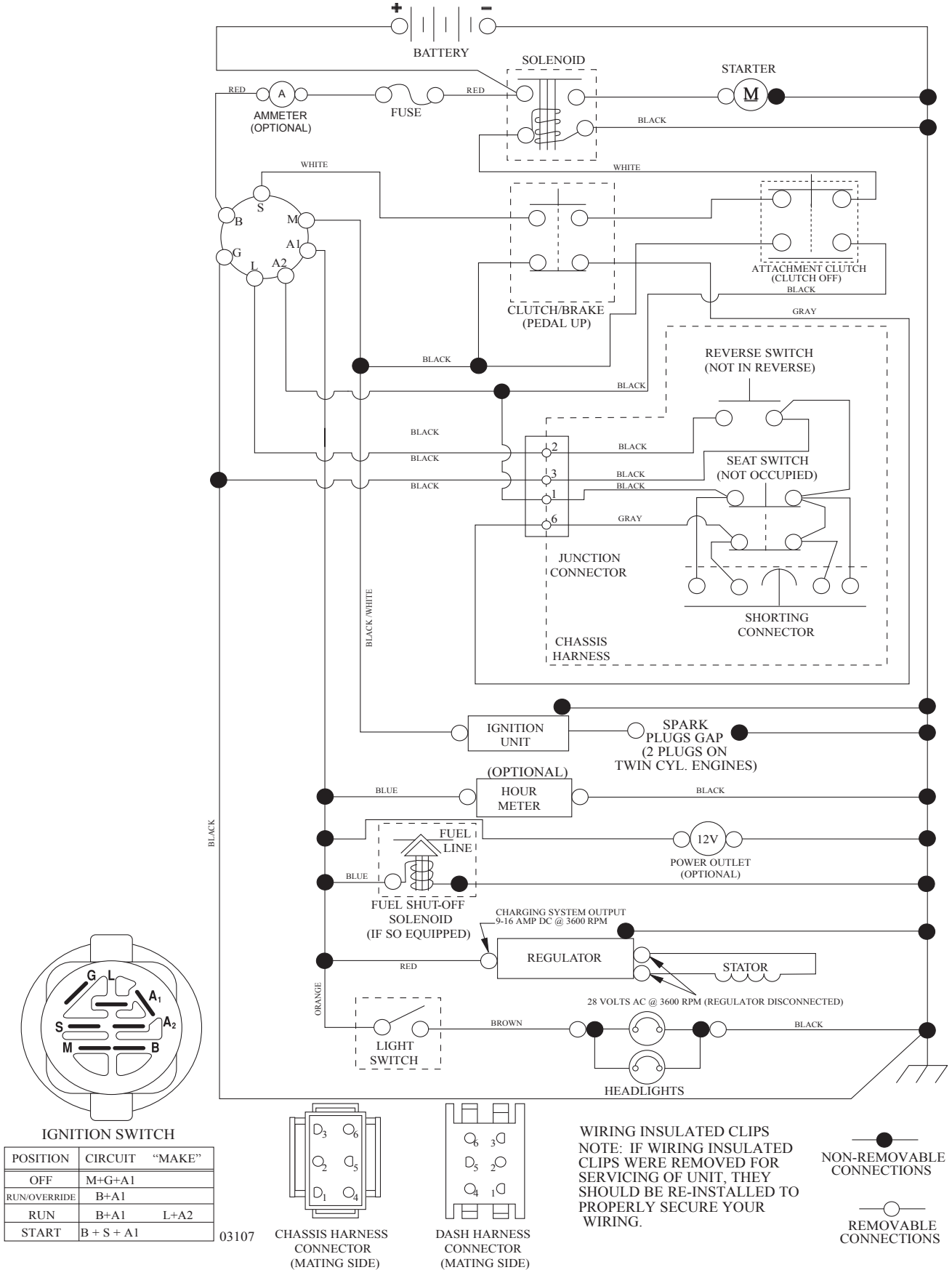

**TRACTOR -- MODEL NUMBER YTH1942 (96043026700), PRODUCT NO. 960 43 02-67
ELECTRICAL**

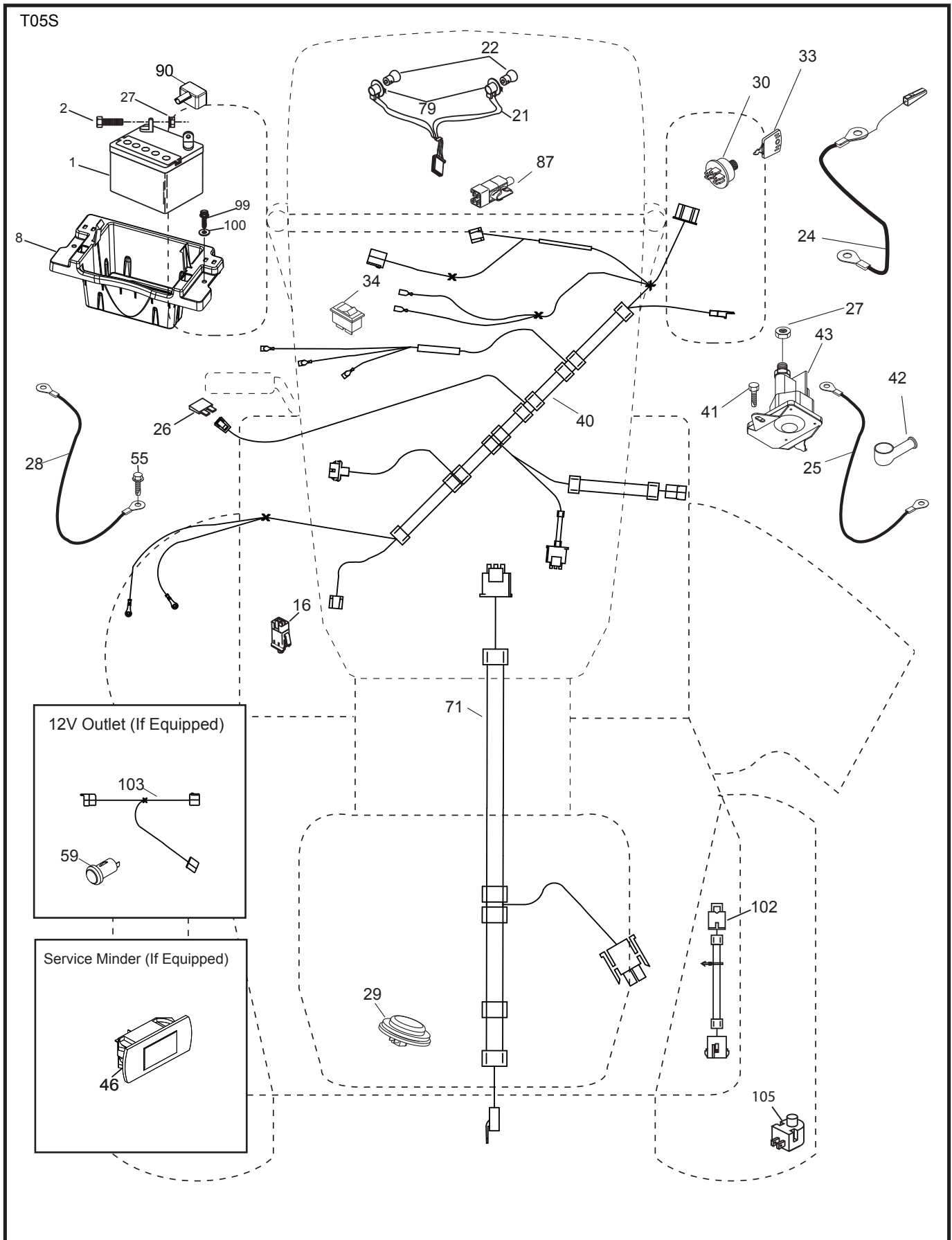

**TRACTOR - - MODEL NUMBER YTH1942 (96043026700), PRODUCT NO. 960 43 02-67
ELECTRICAL**

KEY NO.	PART NO.	DESCRIPTION
1	532 16 34-65	Battery
2	874 76 04-12	Bolt Hex Head 1/4-20 x 3/4
8	532 41 41-26	Box Tray
16	532 17 61-38	Switch Interlock Push-In
21	532 40 02-52	Harness Socket Light w/4152J
22	532 00 41-52	Bulb Light
24	585 55 56-01	Cable Fr. Batt.
25	585 55 55-01	Cable Starter
26	532 17 51-58	Fuse
27	596 13 36-01	Locknut, Keps. 1/4-20
28	532 41 65-88	Cable, Ground
29	532 40 15-45	Switch, Seat
30	532 19 33-50	Switch, Ign
33	532 41 19-33	Key/Chain
34	532 11 07-12	Switch Light/Reset
40	501 13 30-01	Harness Ign. Dash
41	817 72 04-08	Screw 1/4-20 x 1/2
42	532 13 15-63	Cover Terminal
43	582 04 28-02	Solenoid, W/Brass, Plunger, ZN
55	817 06 05-12	Screw Thdrol 5/16-18 x 3/4
71	532 19 42-76	Harness Chassis
79	532 17 52-42	Socket Asm Bulb Twistlock
87	532 19 78-02	Switch Interlock Clutch Cable
90	532 43 53-95	Cover, Terminal Battery
99	817 67 04-12	Screw
100	596 13 53-01	Washer, Plain 9/32 x 7/8 Clr. Zn.
102	532 40 44-54	Harness Pigtail
105	532 40 75-68	Switch Reverse

NOTE: All component dimensions given in U.S. inches
1 inch = 25.4 mm

TRACTOR -- MODEL NUMBER YTH1942 (96043026700), PRODUCT NO. 960 43 02-67
CHASSIS

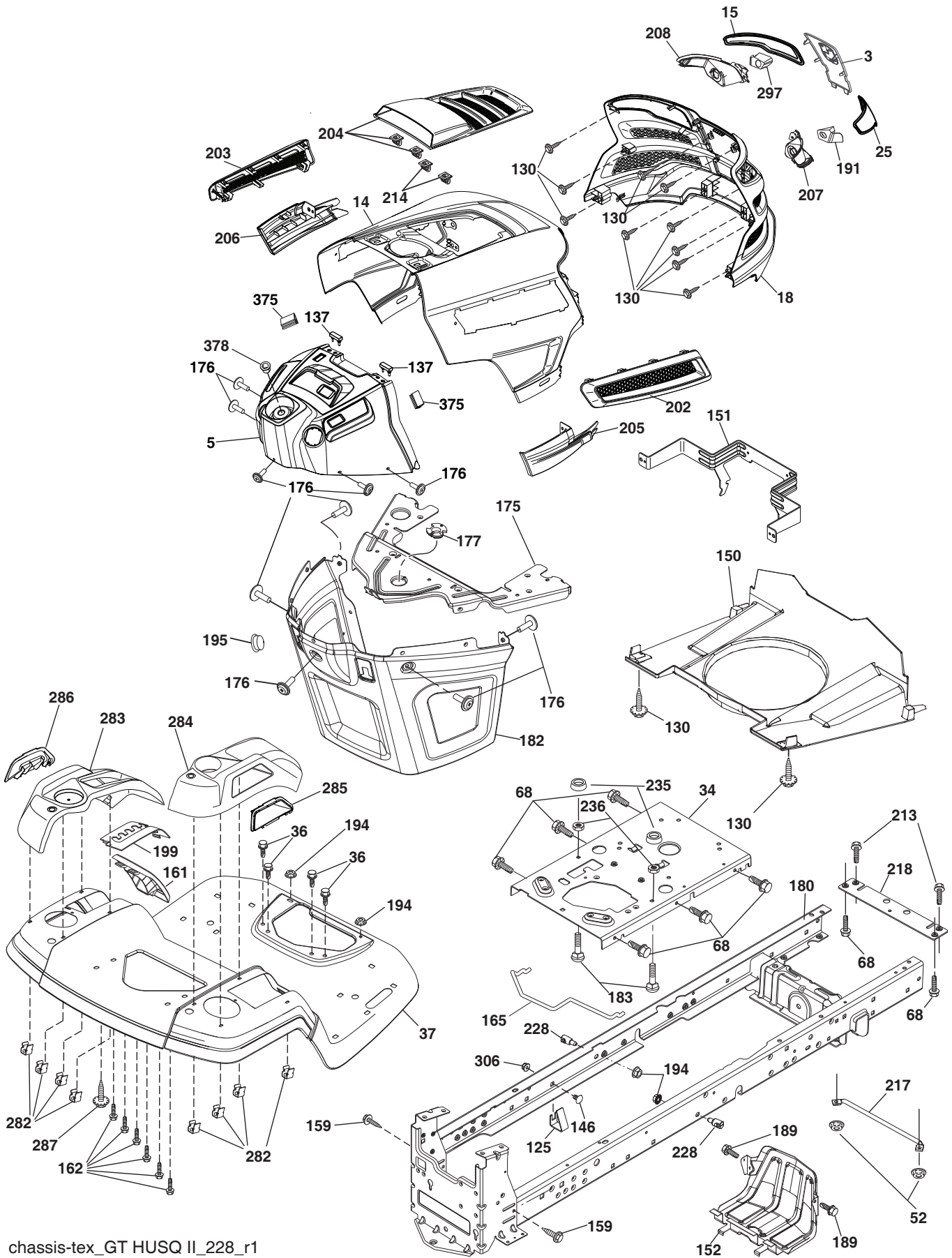

chassis-tex_GT HUSQ II_228_r1

**TRACTOR - - MODEL NUMBER YTH1942 (96043026700), PRODUCT NO. 960 43 02-67
CHASSIS**

KEY NO.	PART NO.	DESCRIPTION	KEY NO.	PART NO.	DESCRIPTION
3	532 44 44-81	Applique	202	532 43 97-28	Vent Side Hood RH
5	590 74 88-18	Dashboard, Upper, Asm. Gt2 x498	203	532 43 97-27	Vent Side Hood LH
14	532 44 11-77	Hood	204	587 48 58-01	Vent, Top, Asm.
15	532 43 97-33	Lens LH	205	532 43 97-30	Side Trim RH
18	587 52 34-01	Grille, Husqavarna, Gray, GT2	206	532 43 97-29	Side Trim LH
25	532 44 33-85	Lens RH	207	587 46 48-01	Headlight, Cup, Bezel, Hus, RH
34	580 91 08-01	Plate Engine	208	587 46 45-01	Headlight, Cup, Bezel, Hus, LH
36	817 06 05-12	Screw 5/16-18 x 3/4	213	596 03 05-01	Bolt, Hex. Hd. 5/16-18 unc x 3/4
37	532 44 11-78	Fender	214	532 19 91-45	Clip Retainer Tinner
52	596 04 05-01	Nutlock, Hex. Prvl. 5/16-18	217	532 40 91-67	Rod Pivot
68	596 03 07-01	Screw, Hexagon, 5/16-18 x 1/2	218	532 19 63-95	X-Piece Hood Stop
125	581 68 48-01	Clip Fuel Line	228	593 82 40-01	Stud, W/"D" Anti-rotation
130	596 32 17-01	Screw, #10 x 0.750 BOS Thread	235	596 56 42-01	Spacer, Fender, Clr. Zn
137	532 40 75-90	Bumper Dash	236	873 93 05-00	Nut Lock 5/16-18 unc
146	581 85 79-01	Bolt	282	532 41 41-10	Clip Retainer Console
150	532 43 97-31	Air Duct	283	532 43 98-61	Console Deck Lift
151	532 43 66-70	Bracket Pivot Hood	284	532 43 98-23	Console Shift
152	532 43 98-70	Shield Browning	285	532 41 63-15	Console Insert RH
159	817 00 06-12	Screw 3/8-16 x 3/4	286	532 41 63-17	Console Insert LH
161	532 43 97-81	Fuel Window Console	287	817 60 04-06	Screw 1/4-20 x 3/8
162	596 13 41-01	Screw, Hex. Tap. 1/4-15 x 1/2	297	532 43 74-56	Insert Reflective LH
165	532 19 68-26	Support Rear Tank	306	873 90 06-00	Nut Lock
175	590 60 77-02	Crossmember	375	586 90 82-01	Dash Clip-On Bumper
176	532 40 07-76	Screw 10-24 x 5/8	378	590 84 98-01	Bushing, Flange, Plastic
177	532 19 52-28	Bushing Steering	--	532 43 99-76	Dash Plug reminder
180	532 19 54-57	Chassis			
182	586 73 86-02	Dash Lower			
183	595 30 57-01	Screw, Hexagon, 5/16-18 x 1-1/4			
189	817 00 05-12	Screw 5/16-18 x 3/4			
191	532 43 74-55	Insert Reflective RH			
194	596 13 57-01	Nutlock, Prvl, Torq. 5/16-18 x .68			
195	532 40 41-37	Plug Dash			
199	532 41 34-85	Plate Deck Lift			

NOTE: All component dimensions given in U.S. inches
1 inch = 25.4 mm

TRACTOR - - MODEL NUMBER YTH1942 (96043026700), PRODUCT NO. 960 43 02-67
DRIVE

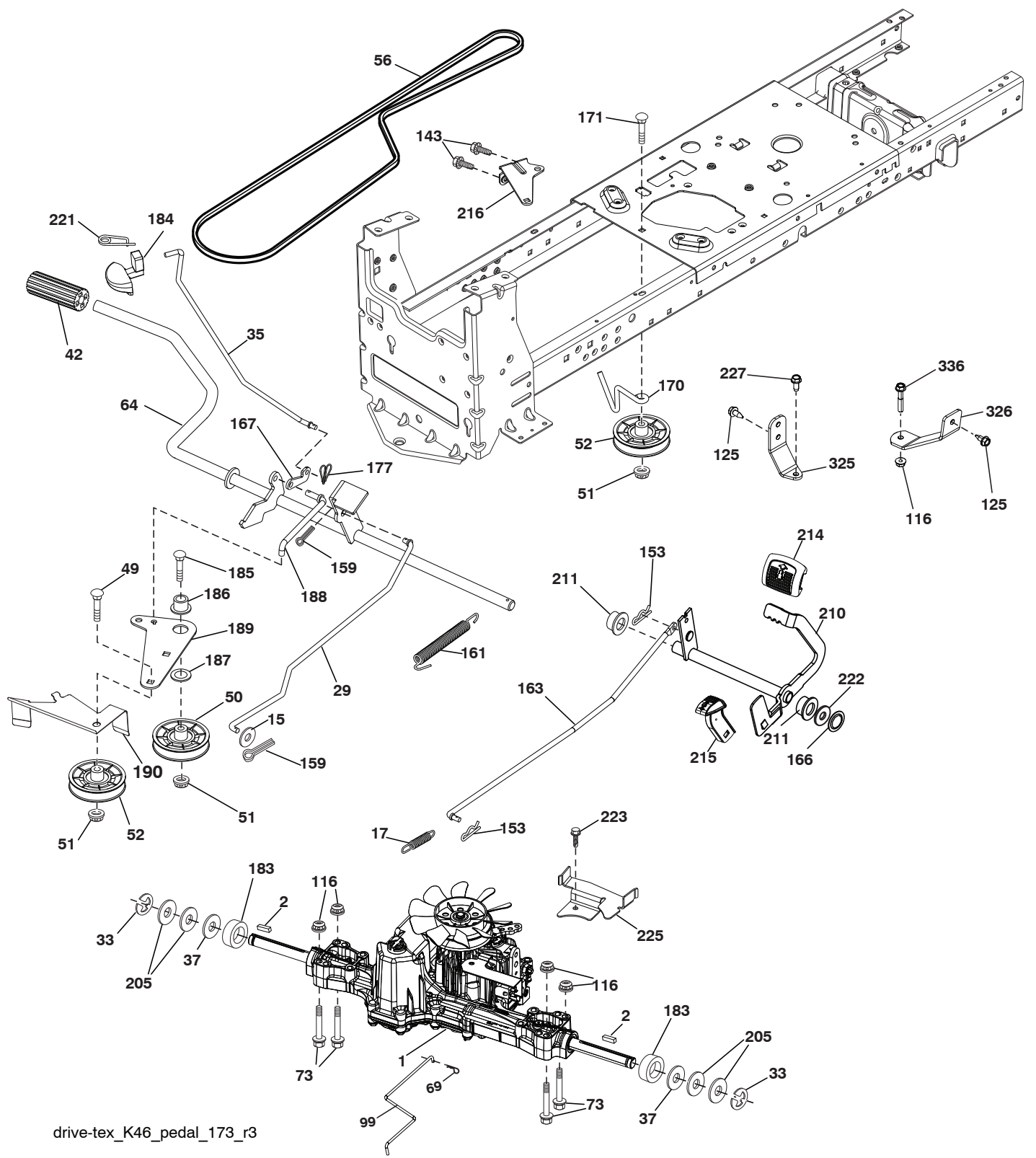

drive-tex_K46_pedal_173_r3

TRACTOR - - MODEL NUMBER YTH1942 (96043026700), PRODUCT NO. 960 43 02-67 DRIVE

KEY NO.	PART NO.	DESCRIPTION	KEY NO.	PART NO.	DESCRIPTION
1	---	Transaxle, Tufftorq K46BT (532426120) (Order parts from transaxle manufacturer)	171	596 13 63-01	Bolt, Cup, head 3/8-16 x 2
2	532 12 35-83	Key Square	177	587 22 53-01	Pin, Cotter, Locking, Bowtie, 1 In.
15	596 56 53-01	Washer, 3/8 x 0.08 in. St. Clr. Zinc	183	532 13 70-57	Spacer Axle
17	532 41 36-78	Spring, Brake	184	587 65 37-01	Handle Parking Brake
29	532 40 38-06	Rod, Brake	185	872 11 06-22	Bolt
33	812 00 00-01	Ring E	186	532 19 43-21	Spacer Retainer
35	590 60 59-02	Rod, Brake, Park	187	596 13 55-01	Washer, 13/32 x 2 Clear, Zinc
37	532 18 89-67	Washer .793 x 1.637 x 060	188	582 21 70-01	Link Clutch Ground Drive, Long
42	532 00 88-83	Cover, Pedal, Blk. Round	189	532 19 43-17	Bellcrank Ground Drive
49	596 13 62-01	Bolt, Cup Head, 3/8-16 x 3/4	190	532 19 43-18	Keeper Bellcrank Ground Drive
50	532 19 43-27	Pulley Idler Flat	205	532 12 17-48	Washer 25/32 x 1-5/8 x 16 Ga.
51	873 90 06-00	Lock Nut 3/8-16	210	532 40 09-80	Rocker Asm. Pedal Control
52	532 19 43-26	Idler V-Groove	211	532 12 01-83	Bearing Nylon
56	592 85 52-01	Belt, Drive, Tex. K46	214	532 42 12-63	Pedal Forward
64	532 19 78-65	Shaft Asm. Pedal Brake Control	215	586 60 65-02	Pedal Reverse
69	532 42 33-03	Hairpin Soft Zinc	216	532 19 61-31	Bracket Pulley Idler
73	596 13 65-01	Bolt, Hex. Head, 5/16-18 x 1-1/2	221	532 40 31-87	Retainer Spring Clip Handle
99	582 40 45-01	Rod Bypass	222	879 21 20-10	Washer 21/32 x 1-1/4 10 Ga.
116	596 13 57-01	Nutlock, Prvl. Torq. 5/16-18 x .68	223	598 66 26-01	Bolt, T45. 5/16-18 x .75 Hexhd Blk
125	817 00 05-12	Screw 5/16-18 x 3/4	225	532 40 33-19	Keeper Belt Transaxle
143	596 03 07-01	Screw, Hexagon, 5/16-18 x 1/2	227	596 13 59-01	Bolt, Hex. 5/16-18 x 3/4 Clr. Znc.
153	532 00 44-97	Retainer, Spring, 1" Zinc/CAD	325	585 66 85-02	Torque Strap K46 LT RH
159	596 02 95-01	Pin, Cotter, 1/8 Dia. X 3/4	326	585 67 08-02	Bracket TRQ STP 46 20" Tire RH
161	532 10 57-09	Spring, Return, Clutch	336	587 25 96-02	Bolt 5/16-18 x 1-3/4 Flanged
163	593 86 10-01	Rod, Control, K46/K57R			
166	532 42 91-64	Nut Push			
167	532 40 52-57	Latch Brake Parking			
170	532 19 43-22	Keeper V-Idler			

NOTE: All component dimensions given in U.S. inches
1 inch = 25.4 mm

**TRACTOR - - MODEL NUMBER YTH1942 (96043026700), PRODUCT NO. 960 43 02-67
ENGINE**

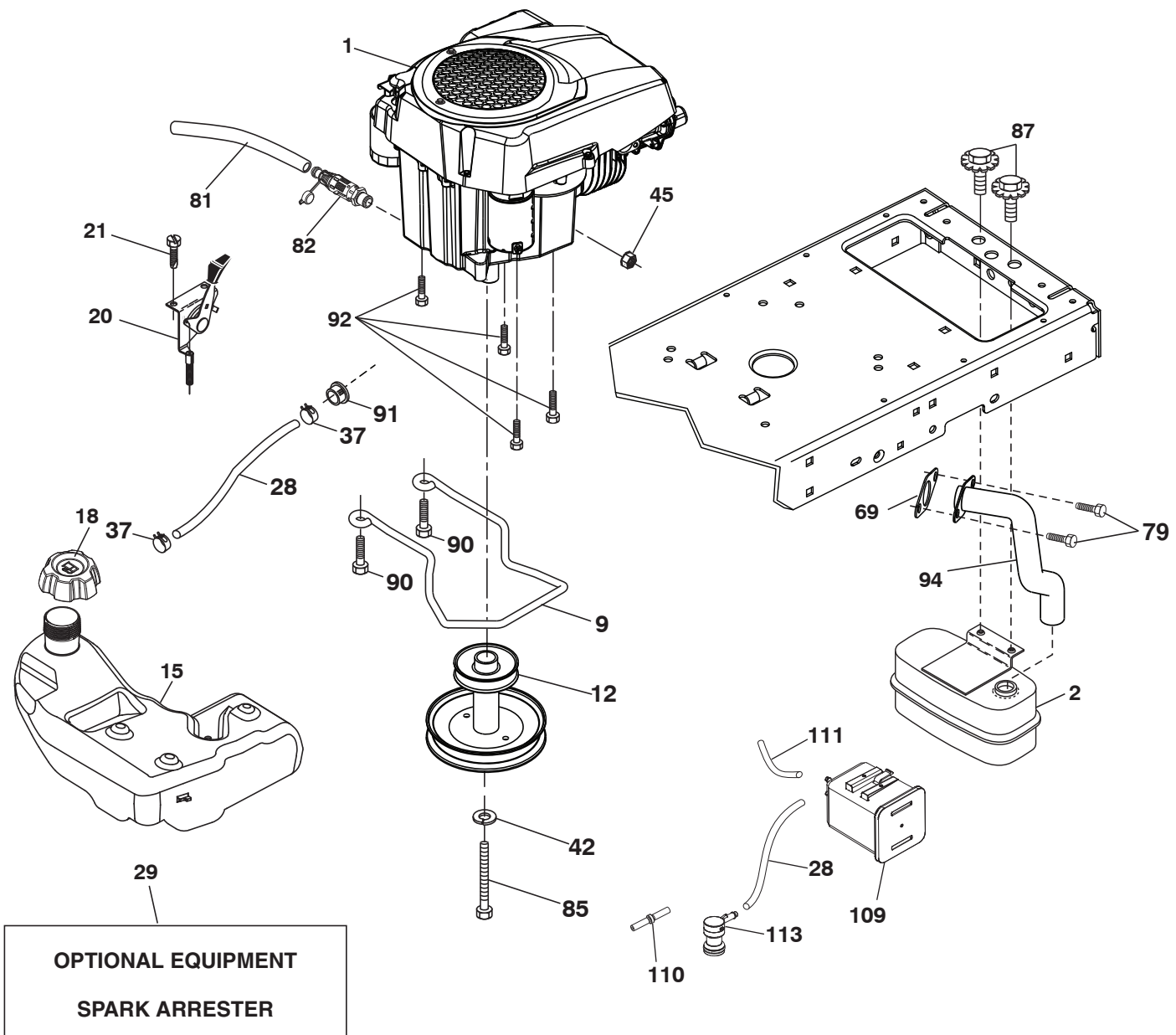

engine-tex_loncin_6_r1

**TRACTOR - - MODEL NUMBER YTH1942 (96043026700), PRODUCT NO. 960 43 02-67
ENGINE**

KEY NO.	PART NO.	DESCRIPTION
1	593 23 01-01	Engine, Husqvarna Model No. HV 608CC Engine IPL Available Separately.
2	590 64 53-01	Muffler
9	501 83 26-02	Keeper Belt Engine
12	586 47 85-01	Pulley Engine
15	599 83 76-01	Fuel, Tank, Asm. 3 Gal. Rr 2020
18	599 50 22-01	Fuel, Cap, Asm. 3" W/Grease
20	532 18 38-97	Control Throttle
21	596 32 17-01	Screw, #10 x 0.750 BOS Thread
28	532 40 11-37	Fuel Line
29	532 13 71-80	Spark Arrester Kit
37	532 12 34-87	Clamp Hose
42	596 23 89-01	Washer, 7/16 in. Clr. Zn
45	593 35 64-01	Nut Hexgaon Flanged
69	590 86 36-01	Gasket
79	596 13 42-02	Screw, Hex. Socket, 5/16-18 x 1 Clr. Zn
81	532 14 84-56	Tube Drain Oil Easy
82	532 42 82-87	Valve Drain Oil
85	501 60 65-01	Bolt Hex 7/16-20 x 4 Gr. 5
87	532 17 18-77	Bolt 5/16-18 unc x 3/4 w/sems
90	817 00 06-16	Screw 3/8-16 x 1
91	532 18 74-95	Bushing
92	817 12 06-16	Screw 3/8 x 1
94	590 86 48-01	Exhaust Tube
109	532 41 41-14	Canister Carbon
111	596 94 15-01	Tube, Purge, Fuel .1875"
110	532 41 41-18	Valve Asm Anit Slosh
113	532 41 41-27	Valve Slant Cartridge

NOTE: All component dimensions given in U.S. inches
1 inch = 25.4 mm

TRACTOR - - MODEL NUMBER YTH1942 (96043026700), PRODUCT NO. 960 43 02-67
STEERING ASSEMBLY

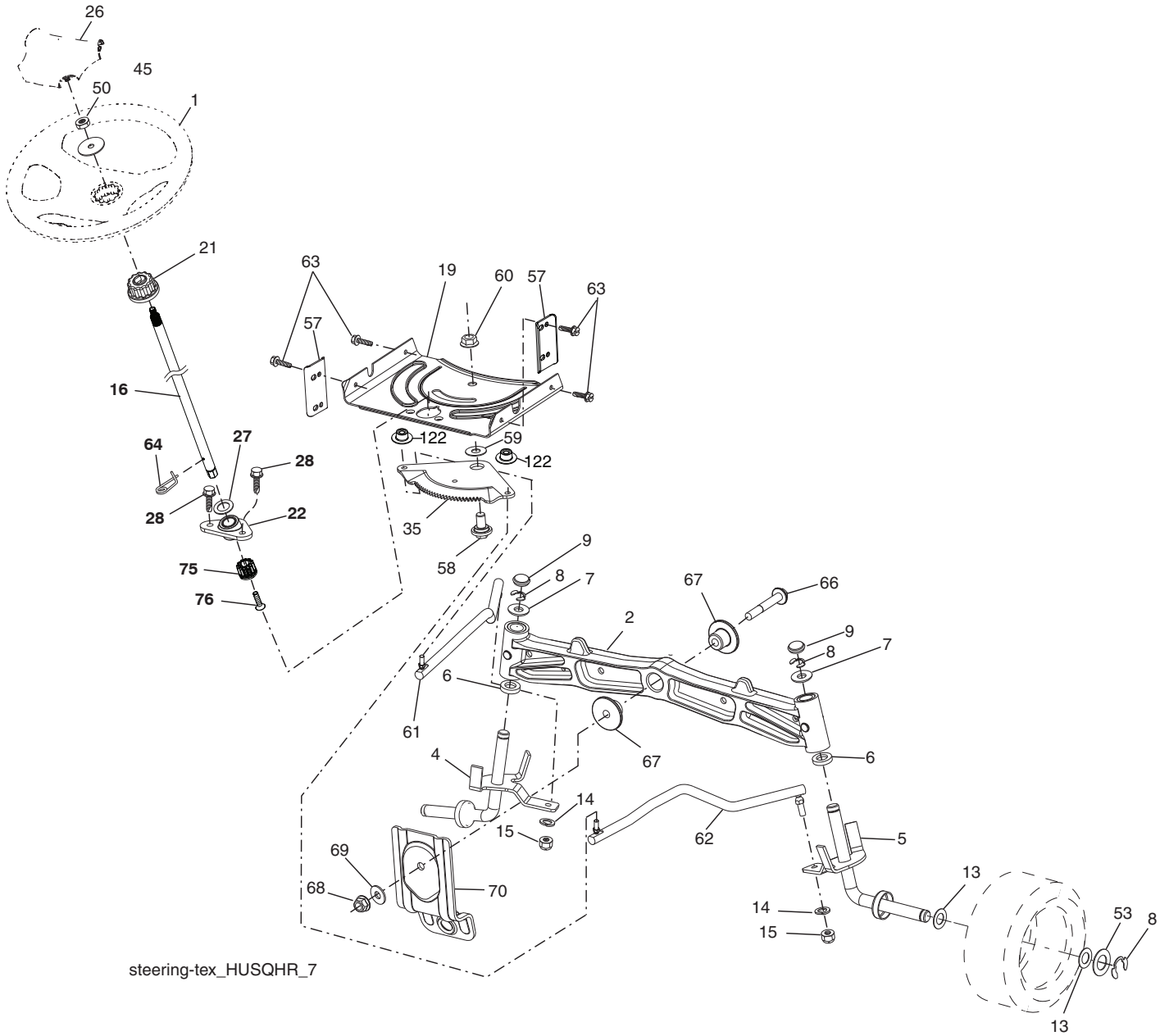

steering-tex_HUSQHR_7

**TRACTOR - - MODEL NUMBER YTH1942 (96043026700), PRODUCT NO. 960 43 02-67
STEERING ASSEMBLY**

KEY NO.	PART NO.	DESCRIPTION
1	532 43 97-40	Wheel, Steering
2	532 19 59-68	Axle Asm., Front
4	532 40 30-87	Spindle Asm., LH
5	532 40 30-88	Spindle Asm., RH
6	532 00 62-66	Washer, Thrust, .75 x 1.230
7	532 12 17-48	Washer 25/32 x 1-5/8 x 16 Ga.
8	812 00 00-29	Ring, Klip #T5304-75
9	532 12 12-32	Cap, Spindle
13	532 12 17-49	Washer 25/32 x 1-1/4 x 16 Ga.
14	596 23 87-01	Washer, Spring, Lock, .381 ID x .680
15	873 54 06-00	Nut, Crown Lock 3/8-24 unf
16	587 01 60-02	Shaft Steering
19	532 19 47-29	Plate Steering
21	586 84 02-01	Adapter Wheel Steering
22	585 02 98-02	Bearing
26	532 43 97-43	Insert, Wheel Steering
27	596 93 34-01	Washer, Plain
28	817 00 06-12	Screw 3/8-16 x 3/4
35	532 19 47-32	Gear, Sector Plate
45	587 01 64-01	Washer 3/8 ID 2-3/8 OD 12 Ga. PLTD
50	873 90 06-00	Nut Lock Flg 3/8-16 unc
53	532 18 89-67	Washer Hardened .793 x 1.637 x .060
57	532 40 74-65	Bracket Upstop
58	532 19 47-47	Bolt Shoulder Sector Pivot CFM
59	532 19 47-48	Washer Thrust Sector Steering
60	873 97 10-00	Nut Flange Lock 5/8-11
61	597 07 02-02	Draglink, LH. Adj. Std. Clrzn.
62	597 07 03-02	Draglink, RH. Adj. Std. Clrzn.
63	817 00 05-12	Screw 5/16-18 x 3/4
64	532 19 98-49	Retainer Clip Spring Steering
66	871 02 07-48	Bolt Hex Fghd 7/16-14 x 3 Serr
67	532 19 47-37	Bushing PM Front Axle
68	873 90 07-00	Nut Lock Flange 7/16-14 Gr. 5
69	532 19 91-62	Washer 1.5 x .505 x .118
70	585 33 88-01	Bracket Deck Susp. Front
75	580 68 37-01	Pinion
76	580 68 36-01	Screw Head Sock
122	532 44 49-62	Cap Gear Sector

NOTE: All component dimensions given in U.S. inches
1 inch = 25.4 mm

**TRACTOR - - MODEL NUMBER YTH1942 (96043026700), PRODUCT NO. 960 43 02-67
MOWER DECK**

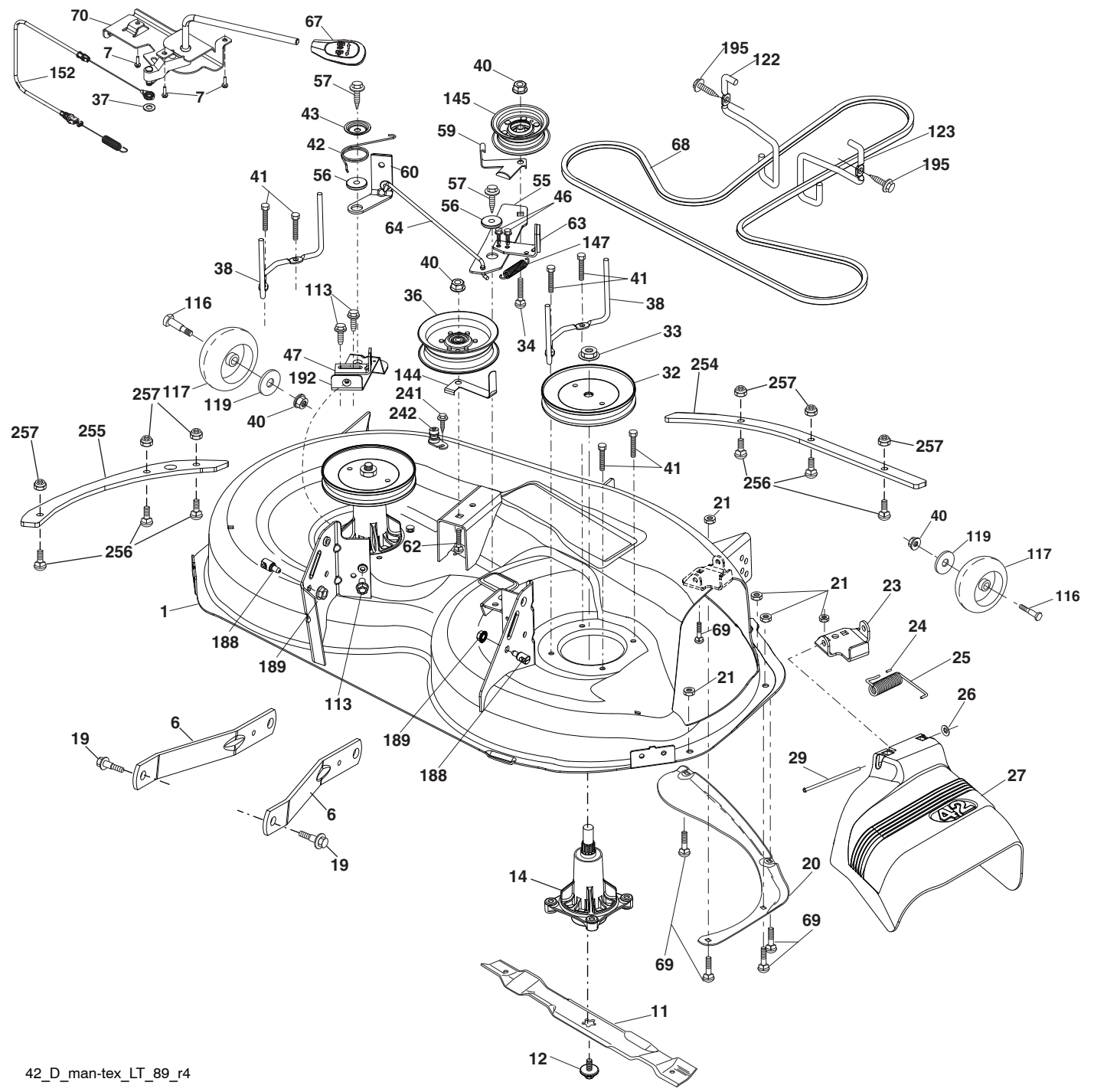

42_D_man-tex_LT_89_r4

**TRACTOR - - MODEL NUMBER YTH1942 (96043026700), PRODUCT NO. 960 43 02-67
MOWER DECK**

KEY NO.	PART NO.	DESCRIPTION	KEY NO.	PART NO.	DESCRIPTION
1	532 44 78-95	Kit, Svc. Deck, Weldment 42B. Cable X668	60	532 19 72-61	Arm Brake Mower
6	532 19 51-86	Arm Suspension	62	596 13 63-01	Bolt, Cup Head, 3/8-16 x 2
7	596 32 17-01	Screw, #10 x 0.750 BOS Thread	63	532 19 94-77	Arm Brake Mower
11	532 13 89-71	Blade, 42" Hi-Lift (For bagging or discharge)	64	532 19 99-18	Link Brake
12	584 30 93-01	Screw	67	532 40 30-12	Handle Clutch Cable
14	587 81 97-01	Kit, Mandrel, Nongrease, Tall (includes shaft and bolt)	68	532 42 96-36	V-Belt
19	532 19 65-39	Bolt, Shoulder	69	596 13 64-01	Bolt, Cup Head, 5/16-18 x 5/8
20	532 15 97-70	Baffle, Vortex	70	532 19 99-72	Clutch Asm Manual
21	596 04 05-01	Nutlock, Hex. Prvl. 5/16-18	113	817 00 05-10	Screw 5/16-18
23	532 19 25-57	Bracket, Deflector	116	596 43 44-02	Bolt, Shldr. 2.41 x 1.66 x 5" Clr. Zn.
24	532 10 53-04	Cap, Sleeve	117	589 52 74-01	Wheel, Gauge
25	532 19 70-26	Spring, Torsion, Deflector	119	596 13 49-01	Washer, Plain 3/8 x 7/8
26	532 11 04-52	Nut, Push	122	532 19 72-58	Keeper Belt Engine LH
27	532 40 30-04	Shield, Deflector	123	532 19 72-59	Keeper Belt Engine RH
29	595 29 70-01	Rod, Hinge	144	532 19 92-04	Keeper Belt
32	532 19 74-73	Pulley, Mandrel	145	532 19 31-97	Pulley Idler
33	596 13 48-01	Nut, Hex. 9/16-18 x 1.010	147	532 40 19-71	Spring Return
34	596 13 61-01	Bolt, Cup Head, 3/8-16 x 1-1/2	152	584 24 35-01	Manual Clutch Cable
36	532 19 73-79	Pulley, Idler, Flat	188	593 82 40-01	Stud, W/"D" Anti-rotation
37	596 56 53-01	Washer, 3/8 x 0.08 in. St. Clr. Zinc	189	596 13 57-01	Nutlock, Prvl. Torq. 5/16-18 x .68
38	589 67 61-02	Keeper, Blt. Pnt. Mndrl. Pull, 6.25	192	532 19 72-60	Bracket Brake Stand LH
40	873 90 06-00	Nut, Lock Flg. 3/8-16 unc	195	817 00 06-12	Screw 3/8-16 x 3/4
41	584 95 39-01	Bolt Hex Wshrhd 3/8-18 x 1.19	241	532 15 29-27	Screw TT #10-32 5 3/8 Flange
42	532 19 84-10	Spring Torsion Brake	242	532 41 55-98	Port Washout
43	532 19 72-56	Spring Torsion Retainer	254	585 31 68-05	Plate Reinforcement Front
46	532 13 77-29	Screw Thd Roll 1/4-20 x 5/8	255	585 31 70-05	Plate Reinforcement 42"
47	532 19 72-50	Bracket Clutch Cable	256	592 80 78-01	Bolt 1/4-20 x 1" Zn, Square, Neck
55	532 43 71-10	Arm, Idler	257	873 90 04-00	Nut Hex Flange 1/4-20 x 1
56	532 19 90-92	Spacer, Retainer	--	532 41 64-05	Coupling Quick connect
57	817 00 06-16	Screw 3/8-16 x 1	--	532 44 78-93	Replacement Mower, Complete
59	532 14 10-43	Guard, Tuv Idler			

NOTE: All component dimensions given in U.S. inches
1 inch = 25.4 mm

**TRACTOR - - MODEL NUMBER YTH1942 (96043026700), PRODUCT NO. 960 43 02-67
MOWER LIFT**

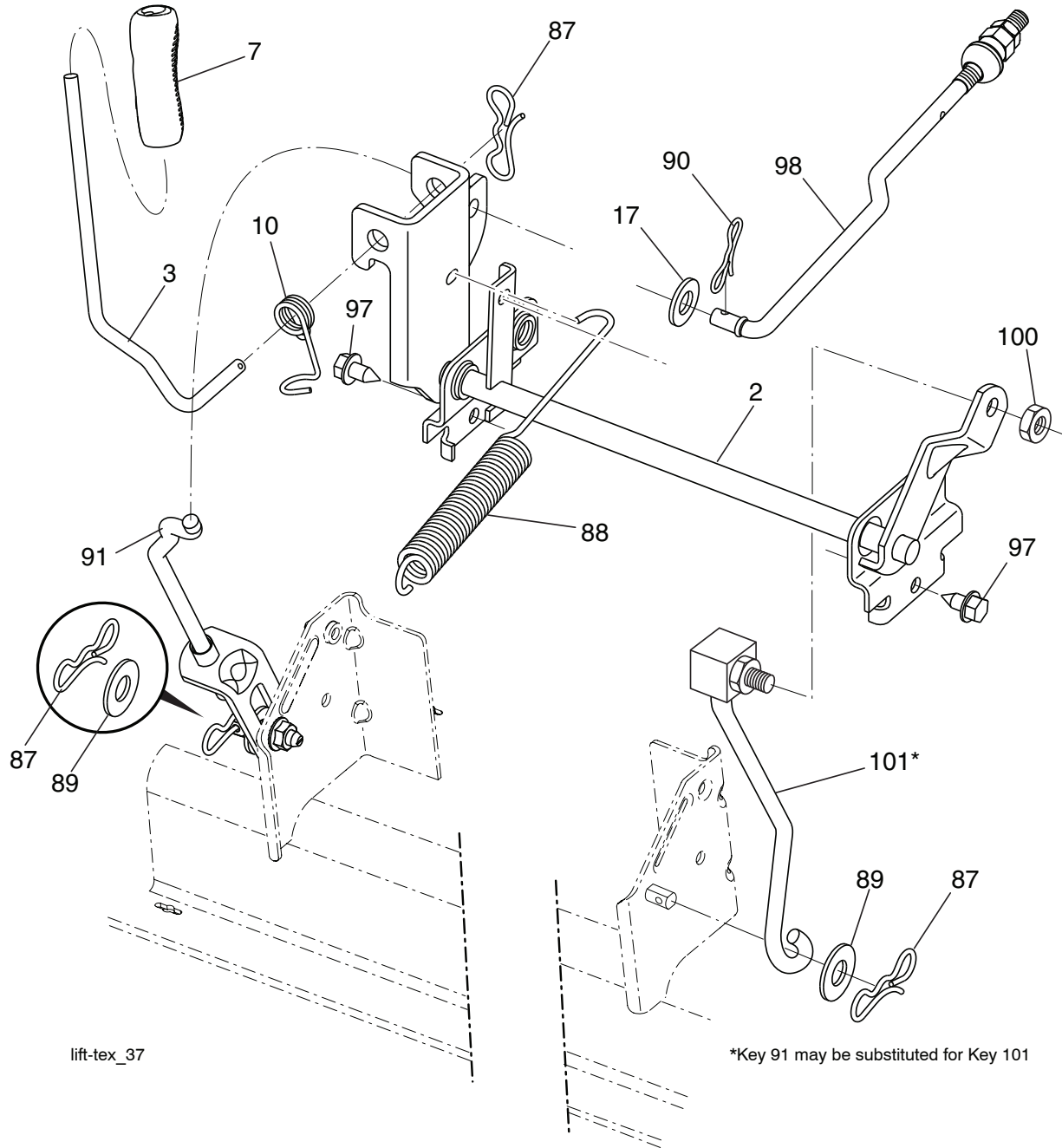

KEY NO.	PART NO.	DESCRIPTION
2	532 42 20-27	Shaft Asm., Lift
3	594 01 80-01	Handle, Lifter, Lt, Std, Wide
7	580 96 23-01	Grip, Lever
10	532 19 63-14	Spring Torsion
17	594 97 65-01	Washer, Round 15/32x 15/16 x .065
87	532 19 42-09	Pin Cotter 7/16 Bow Tie Lock
88	532 41 07-10	Spring Lift Assist
89	819 19 19-12	Washer Clear Zinc
90	532 19 42-08	Pin Cotter 5/16 Bow Tie Lock

KEY NO.	PART NO.	DESCRIPTION
91	589 46 48-03	Link, Assy. Lift, Rear
97	817 00 06-12	Screw Hex Wsh. THDR 3/8-16 x 3/4
98	581 50 69-03	Link, Assy. Mwr. Front, Suspension
100	595 30 59-01	Nut, Hex. Locknut, 3/8-16
101	532 40 70-03	Link Asm. Fixed

NOTE: All component dimensions given in U.S. inches
1 inch = 25.4 mm

**TRACTOR - - MODEL NUMBER YTH1942 (96043026700), PRODUCT NO. 960 43 02-67
SEAT ASSEMBLY**

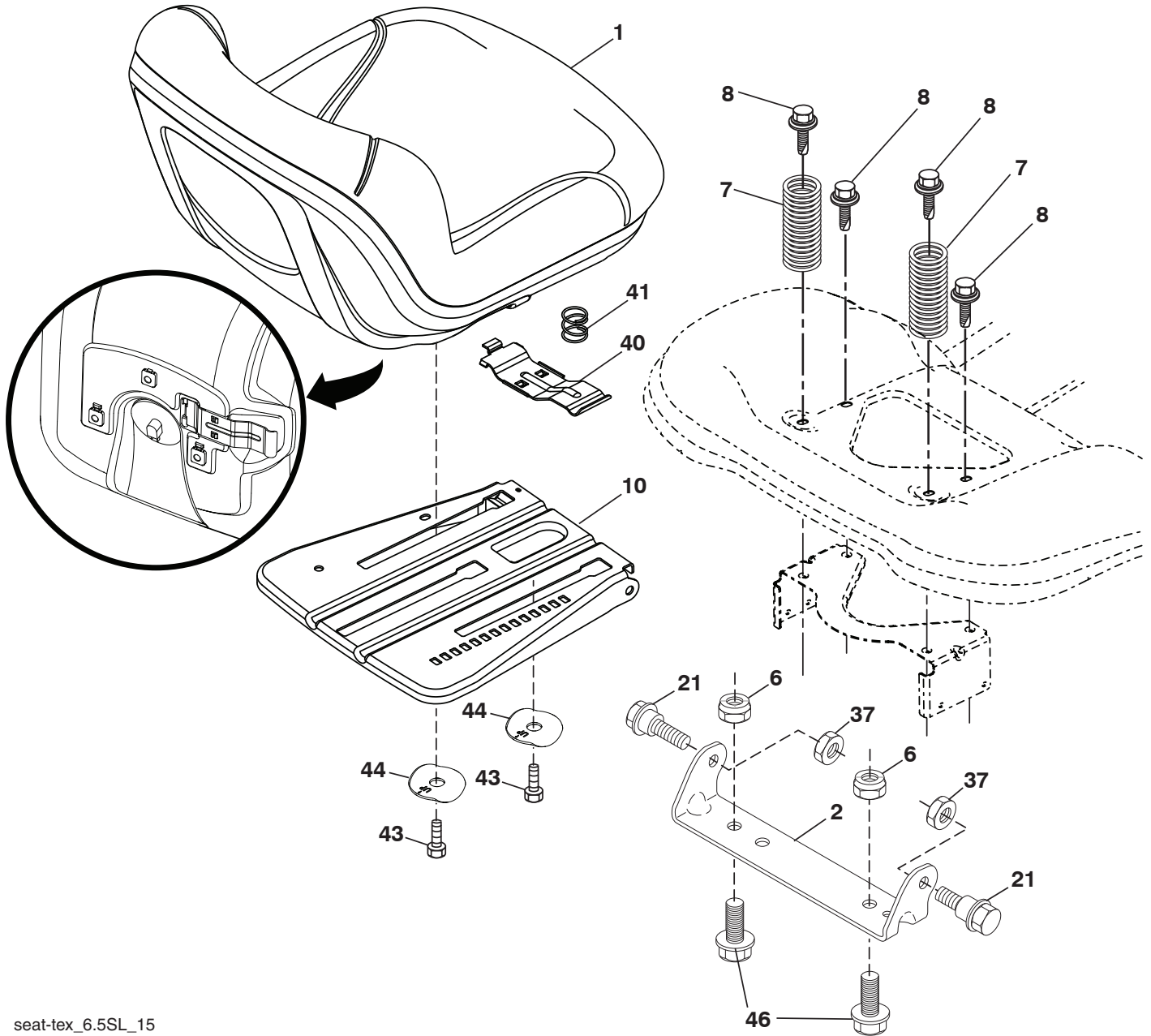

seat-tex_6.5SL_15

KEY NO.	PART NO.	DESCRIPTION
1	532 43 98-19	Seat
2	532 18 01-66	Bracket Pivot Fender
6	873 80 06-00	Nut, Lock w/Ins. 3/8-16 unc
7	589 48 35-01	Spring, Seat Cprsn
8	532 17 18-77	Bolt 5/16-18 unc x 3/4 w/Sems
10	596 65 74-02	Seat, Plate, Slide
21	587 90 78-01	Bolt, Shoulder 5/16-18 x 5/8
37	596 58 37-02	Nut, Hex 5/16-18 unc

KEY NO.	PART NO.	DESCRIPTION
40	595 08 81-02	Handle Slide Seat
41	532 19 82-00	Spring Latch Seat
43	874 76 06-12	Bolt Fin Hex 3/8-16 unc x 3/4
44	501 05 18-01	Washer Winged
46	588 09 04-01	Bolt 3/8-16 x 1, 1.25

NOTE: All component dimensions given in U.S. inches
1 inch = 25.4 mm

**TRACTOR - - MODEL NUMBER YTH1942 (96043026700), PRODUCT NO. 960 43 02-67
DECALS**

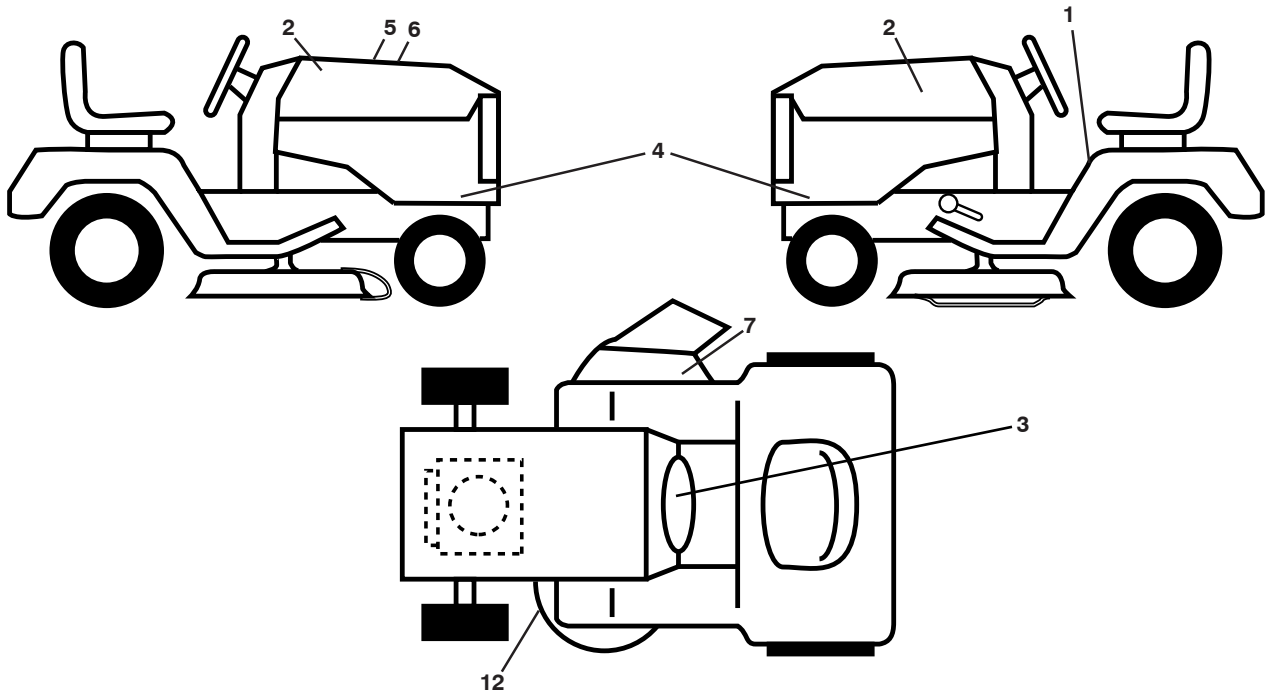

KEY NO.	PART NO.	DESCRIPTION
1	581 57 89-01	Decal, Fender Warn./Instructions
2	501 13 14-01	Decal, Hood Logo
3	596 02 42-01	Decal, Warn. Spark
4	592 88 89-01	Decal, Panel Side
5	532 42 38-29	Decal, Customer Respons.
6	592 87 71-01	Decal, Replacement
7	584 90 46-01	Decal, Deflect. Warning
12	581 58 00-01	Decal, Mower V-Belt Schematic

KEY NO.	PART NO.	DESCRIPTION
--	581 72 48-01	Decal, Bypass
--	532 43 96-81	Pad, Footrest, LH
--	532 43 96-82	Pad, Footrest, RH
--	115 94 97-49	Manual, Operator's (English/Spanish)
--	115 94 98-49	Manual, Parts (English/Spanish)
--	587 71 00-26	Manual, Quick Start Guide (English/Spanish)

WHEELS AND TIRES

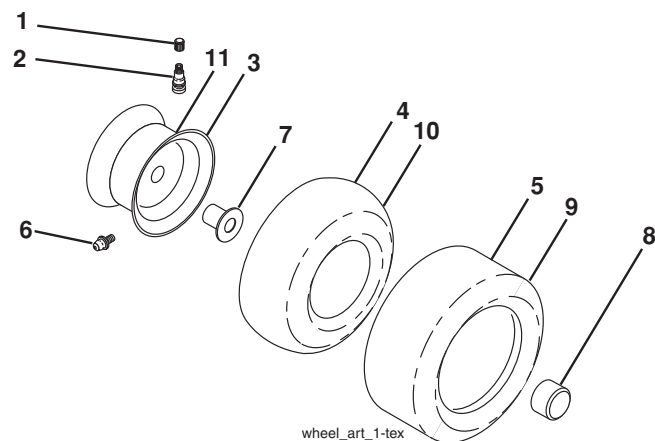

KEY NO.	PART NO.	DESCRIPTION
1	532 05 91-92	Cap Valve Tire
2	532 06 51-39	Stem Valve
3	532 13 83-36	Rim Asm 6" Front
4	532 05 99-04	Tube Front (Service Item Only)
5	532 10 62-22	Tire Front 15 x 6-6
6	532 00 02-78	Fitting, Grease
7	532 00 90-40	Bearing, Flange
8	532 17 50-39	Cap Axle
9	532 13 84-68	Tire Rear 20 x 8-8
10	532 00 71-52	Tube Rear (Service Item Only)
11	532 13 83-37	Rim Asm 8" Rear
--	532 14 43-34	Sealant, Tire (10 oz. Tube)

NOTE: All component dimensions given in U.S. inches
1 inch = 25.4 mm

TRACTOR - - MODELO NO. YTH1942 (96043026700), PRODUCTO NO. 960 43 02-67 DIAGRAMA

SCH10-s

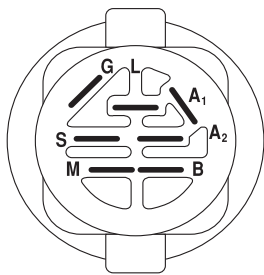
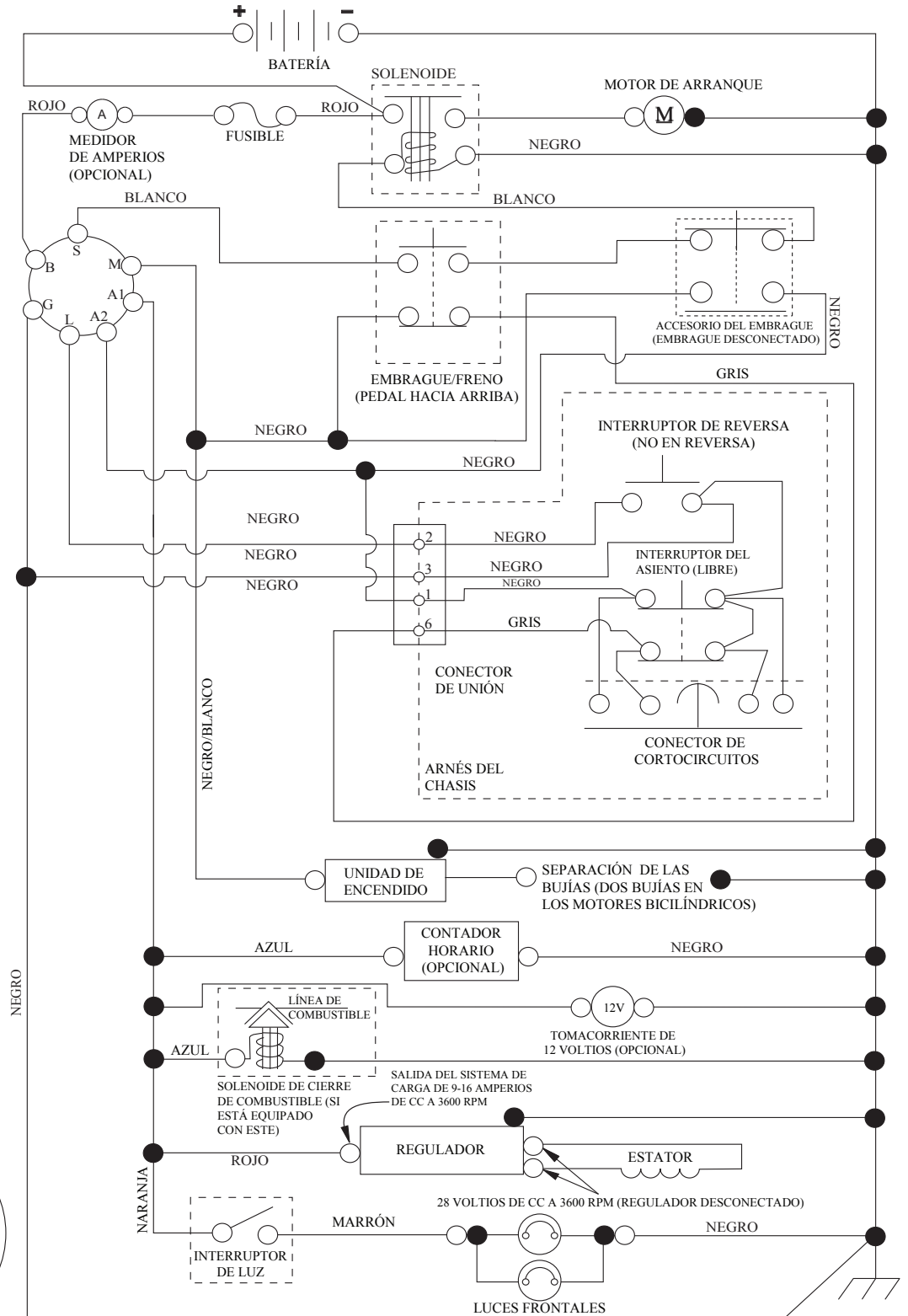

INTERRUPTOR DE ENCENDIDO

POSICIÓN	CIRCUITO «MARCA»
APAGADO	M+G+A1
PONER EN FUNCIONAMIENTO/ANULAR	B+A1
PONER EN FUNCIONAMIENTO	B+A1 L+A2
ARRANCAR	B + S + A1

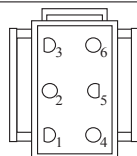

CONEXIÓN DEL ARNÉS DEL CHASIS (LATERAL QUE COINCIDA)

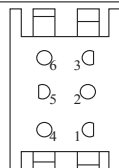

CONEXIÓN PARA EL ARNÉS DEL TABLERO (LATERAL QUE COINCIDA)

NOTA SOBRE LAS ABRAZADERAS DE AISLAMIENTO DEL CABLEADO: SI SE QUITAN LAS ABRAZADERAS DE AISLAMIENTO DEL CABLEADO PARA HACER EL MANTENIMIENTO DE LA UNIDAD, SE LAS DEBERÁ INSTALAR NUEVAMENTE PARA PROTEGER EL CABLEADO ADECUADAMENTE.

● CONEXIONES NO DESMONTABLES

○ CONEXIONES DESMONTABLES

TRACTOR -- MODELO NO. YTH1942 (96043026700), PRODUCTO NO. 960 43 02-67
DIAGRAMA ELÉCTRICO

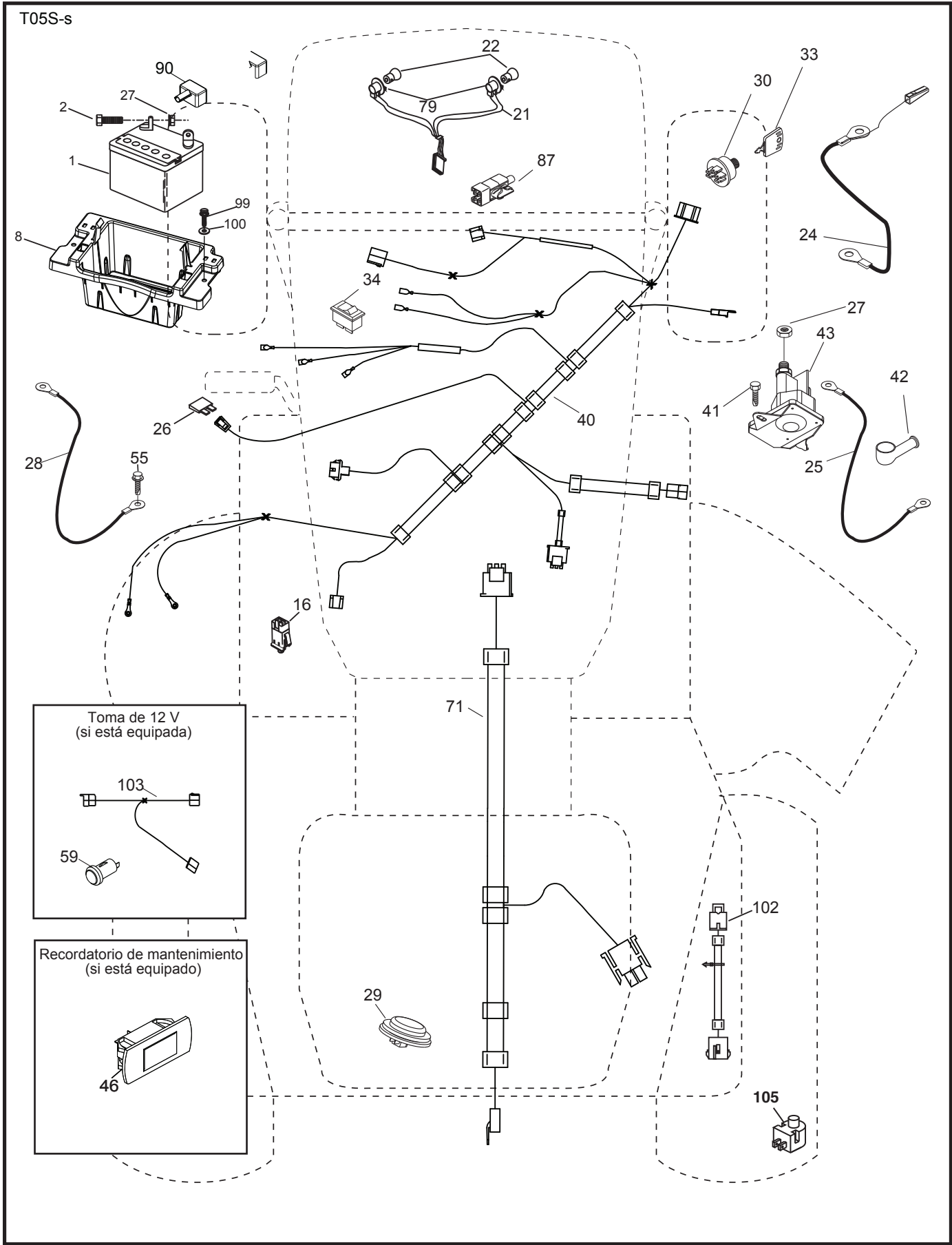

**TRACTOR - - MODELO NO. YTH1942 (96043026700), PRODUCTO NO. 960 43 02-67
DIAGRAMA ELÉCTRICO**

CÓDIGO PIEZA		DESCRIPCIÓN
No.	No.	
1	532 16 34-65	Batería
2	874 76 04-12	Perno de cabeza hexagonal de 1/4-20 x 3/4
8	532 41 41-26	Caja de la batería
16	532 17 61-38	Caja de la batería Interruptor corta corriente a presión
21	532 40 02-52	Cableado del enchufe para la luz c/4152J
22	532 00 41-52	Bombilla de luz
24	585 55 56-01	Cable
25	585 55 55-01	Cable
26	532 17 51-58	Fusible
27	596 13 36-01	Tuerca de 1/4-20
28	532 41 65-88	Cable a tierra
29	532 40 15-45	Interruptor del asiento
30	532 19 33-50	Interruptor de encendido
33	532 41 19-33	Llave/cadena
34	532 11 07-12	Interruptor de luz/de restauración
40	501 13 30-01	Cableado del tablero de encendido
41	817 72 04-08	Tornillo 1/4-20 x 1/2
42	532 13 15-63	Tapa de los bornes de la batería
43	582 04 28-02	Solenoides
55	817 06 05-12	Tornillo de 5/16-18 x 3/4
71	532 19 42-76	Cableado de encendido
79	532 17 52-42	Enchufe de cierre por torsión del ensamble de la bombilla
87	532 19 78-02	Enchufe de cierre por torsión del ensamble de la bombilla
90	532 43 53-95	Tapa de los bornes de la batería
99	817 67 04-12	Tornillo
100	596 13 53-01	Arandela de 9/32 x 7/8
102	532 40 44-54	Cableado
105	532 40 75-68	Interruptor

NOTA: Las dimensiones de todos los componentes están expresadas en pulgadas americanas. 1 pulgada = 25,4 mm

**TRACTOR - - MODELO NO. YTH1942 (96043026700), PRODUCTO NO. 960 43 02-67
CHASIS**

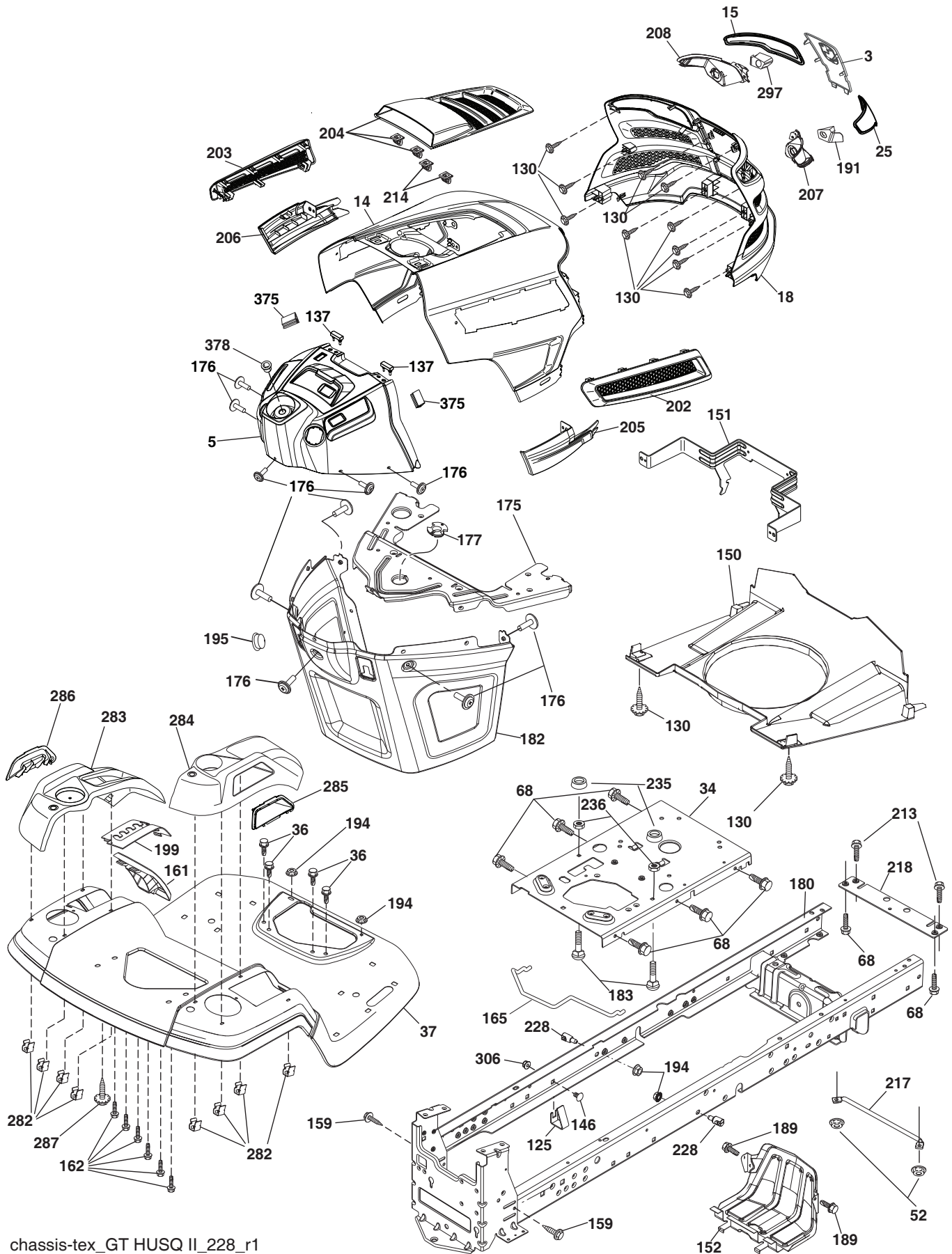

chassis-tex_GT HUSQ II_228_r1

TRACTOR - - MODELO NO. YTH1942 (96043026700), PRODUCTO NO. 960 43 02-67 CHASIS

CÓDIGO NO.	PIEZA NO.	DESCRIPCIÓN	CÓDIGO NO.	PIEZA NO.	DESCRIPCIÓN
3	532 44 44-81	Aplica	203	532 43 97-27	Salida de Ventilación (LI)
5	590 74 88-18	Tablero del tractor el montaje superior	204	587 48 58-01	Salida de Ventilación superior
14	532 44 11-77	Capota	205	532 43 97-30	Camisa (LD)
15	532 43 97-33	Lente izquierdo de la parrilla	206	532 43 97-29	Camisa (LI)
18	587 52 34-01	Parrilla	207	587 46 48-01	Bisel derecho
25	532 44 33-85	Lente derecho de la parrilla	208	587 46 45-01	Bisel izquierdo
34	580 91 08-01	Placa	213	596 03 05-01	Perno de 5/16-18 unc x 3/4
36	817 06 05-12	Tornillo de 5/16-18 x 3/4	214	532 19 91-45	Cierre
37	532 44 11-78	Guardabarros	217	532 40 91-67	Varilla giratoria
52	596 04 05-01	Tuerca de presión de 5/16-18 x .18	218	532 19 63-95	Tope
68	596 03 07-01	Tornillo de 5/16-18 x 1/2	228	593 82 40-01	Perno prisionero con anti rotación
125	581 68 48-01	Soporte	235	596 56 42-01	Separador del guardabarros
130	596 32 17-01	Tornillo de #10 x 0.750	236	873 93 05-00	Tuerca de presión 5/16-18 unc
137	532 40 75-90	Cubierta Tablero	282	532 41 41-10	Pinzas de retención
146	581 85 79-01	Perno	283	532 43 98-61	Consola de la plataforma de elevación
150	532 43 97-31	Cubierta	284	532 43 98-23	Consola cambio
151	532 43 66-70	Soporte de Capota	285	532 41 63-15	Consola inserto (LD)
152	532 43 98-70	Protector contra oscurecimiento	286	532 41 63-17	Consola inserto (LI)
159	817 00 06-12	Tornillo 3/8-16 x 3/4	287	817 60 04-06	Tornillo 1/4-20 X 3/8
161	532 43 97-81	Ventana de combustible	297	532 43 74-56	Parte movable reflexivo (LI)
162	596 13 41-01	Tornillo de 1/4-15 x 1/2	306	873 90 06-00	Tuerca
165	532 19 68-26	Trasero apoyo de tanque	375	586 90 82-01	Cubierta Capota
175	590 60 77-02	Travesaño	378	590 84 98-01	Buje de brida, plástico
176	532 40 07-76	Tornillo de 10-24 x 5/8	--	532 43 18-82	Protector del cepillo
177	532 19 52-28	Buje de dirección	--	532 43 99-76	Enchufe dash recordatorio
180	532 19 54-57	Chasis			
182	586 73 86-02	Tablero inferior			
183	595 30 57-01	Tornillo de 5/16-18 x 1-1/4			
189	817 00 05-12	Tornillo			
191	532 43 74-55	Parte movable reflexivo (LD)			
194	596 13 57-01	Tuerca de presión de 5/16-18 x .68			
195	532 40 41-37	Enchufe Dash			
199	532 41 34-85	Chapa			
202	532 43 97-28	Salida de Ventilación (LD)			

NOTA: Las dimensiones de todos los componentes están expresadas en pulgadas americanas. 1 pulgada = 25,4 mm

TRACTOR - - MODELO NO. YTH1942 (96043026700), PRODUCTO NO. 960 43 02-67
TRANSMISIÓN

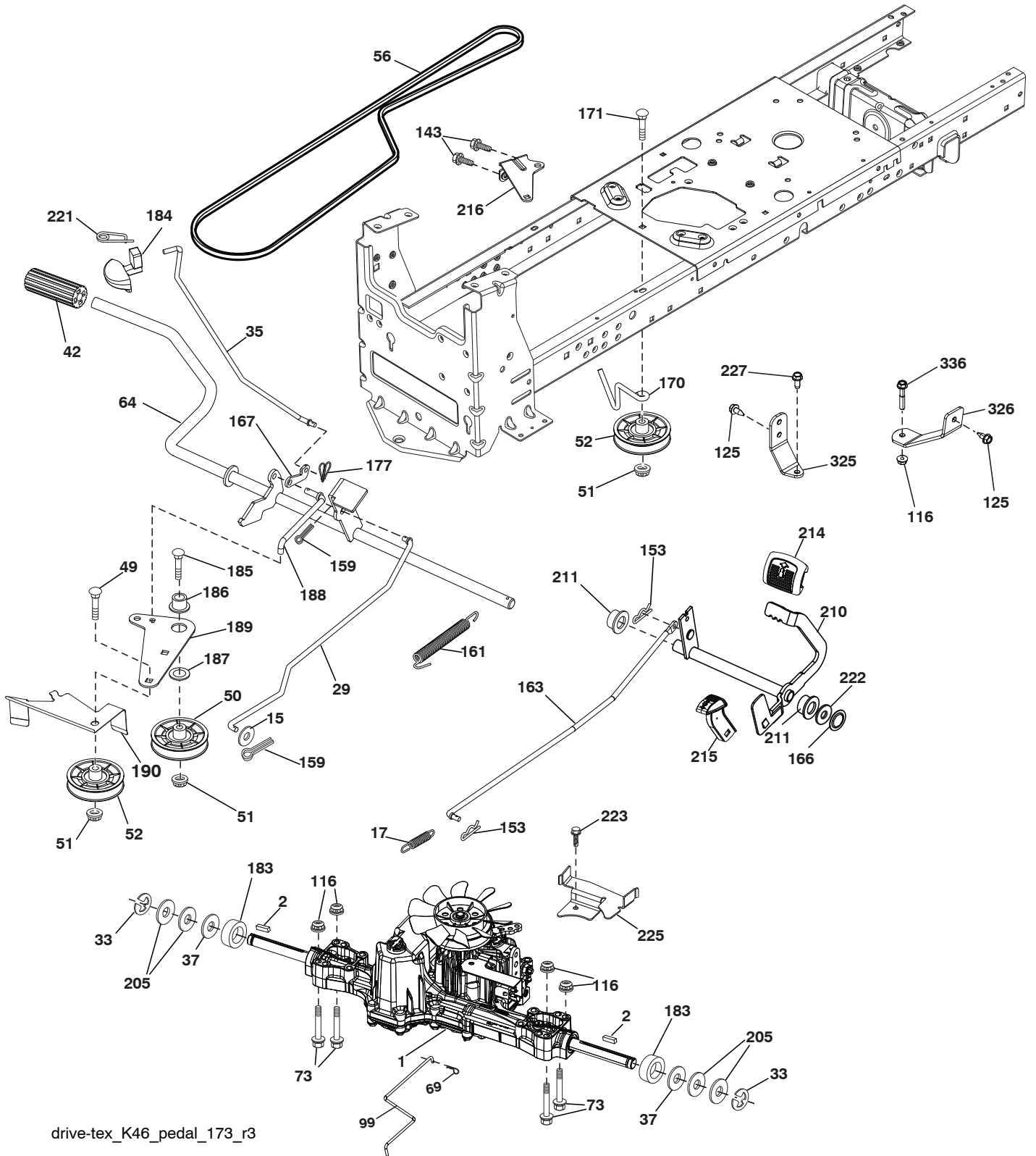

drive-tex_K46_pedal_173_r3

TRACTOR - - MODELO NO. YTH1942 (96043026700), PRODUCTO NO. 960 43 02-67 TRANSMISIÓN

CÓDIGO No.	PIEZA No.	DESCRIPCIÓN	CÓDIGO No.	PIEZA No.	DESCRIPCIÓN
1	---	Transeje, TuffTorq K46BT (532426120) (Haga el pedido de las piezas al fabricante del transeje)	183	532 13 70-57	Separador del eje
2	532 12 35-83	Cuña	184	587 65 37-01	Manija del freno de mano
15	596 56 53-01	Arandela de 3/8 x 0.08	185	872 11 06-22	Perno
17	532 41 36-78	Resorte de freno	186	532 19 43-21	Espaciador de retención
29	532 40 38-06	Varilla del freno	187	596 13 55-01	Arandela de 13/32 x 2
33	812 00 00-01	Aro E	188	582 21 70-01	Mecanismo de desplazamiento de la varilla de mando del embrague del largo
35	590 60 59-02	Varilla del freno de mano	189	532 19 43-17	Palanca acodada del mecanismo de desplazamiento
37	532 18 89-67	Arandela	190	532 19 43-18	Sujetador de la palanca acodada del mecanismo de desplazamiento
42	532 00 88-83	Cubierta del pedal	205	532 12 17-48	Arandela de 25/32 x 1-5/8 calibre 16
49	596 13 62-01	Perno de 3/8-16 x 3/4	210	532 40 09-80	Ensamble del control del pedal
50	532 19 43-27	Polea loca plana	211	532 12 01-83	Rodamiento de nylon
51	873 90 06-00	Tuerca de presión de 3/8-16	214	532 42 12-63	Forro del pedal para avanzar
52	532 19 43-26	Polea loca con ranura en V	215	586 60 65-02	Forro del pedal para retroceder
56	592 85 52-01	Correa, transmisión	216	532 19 61-31	Soporte del Polea
64	532 19 78-65	Ensamble del eje Control del pedal de freno	221	532 40 31-87	Abrazadera de retención del resorte de la manija
69	532 42 33-03	Horquilla de Zinc suave	222	879 21 20-10	Arandela de 21/32 x 1-1/4 calibre 10
73	596 13 65-01	Perno de 5/16-18 x 1-1/2	223	598 66 26-01	Perno de T45. 5/16-18 x .75
99	582 40 45-01	Varilla del ensamble con resorte de desviación	225	532 40 33-19	Sujetador de la correa
116	596 13 57-01	Tuerca de 5/16-18 x .68	227	596 13 59-01	Perno de 5/16-18 x 3/4
125	817 00 05-12	Tornillo de 5/16-18 x 3/4	325	585 66 85-02	Soporte
143	596 03 07-01	Tornillo de 5/16-18 x 1/2	326	585 67 08-02	Soporte
153	532 00 44-97	Pince d' arrêtoir 1"	336	587 25 96-02	Perno de 5/16-18 x 1-3/4
159	596 02 95-01	Pasador de chaveta de 1/8 x 3/4			
161	532 10 57-09	Resorte de retorno del embrague			
163	593 86 10-01	Tige, K46/K57R			
166	532 42 91-64	Tuerca de presión			
167	532 40 52-57	Pestillo del freno de mano			
170	532 19 43-22	Sujetador de la correa			
171	596 13 63-01	Perno de 3/8-16 x 2			
177	587 22 53-01	Abrazadera de retención 1 In.			

NOTA: Las dimensiones de todos los componentes están expresadas en pulgadas americanas. 1 pulgada = 25,4 mm

TRACTOR - - MODELO NO. YTH1942 (96043026700), PRODUCTO NO. 960 43 02-67
MOTOR

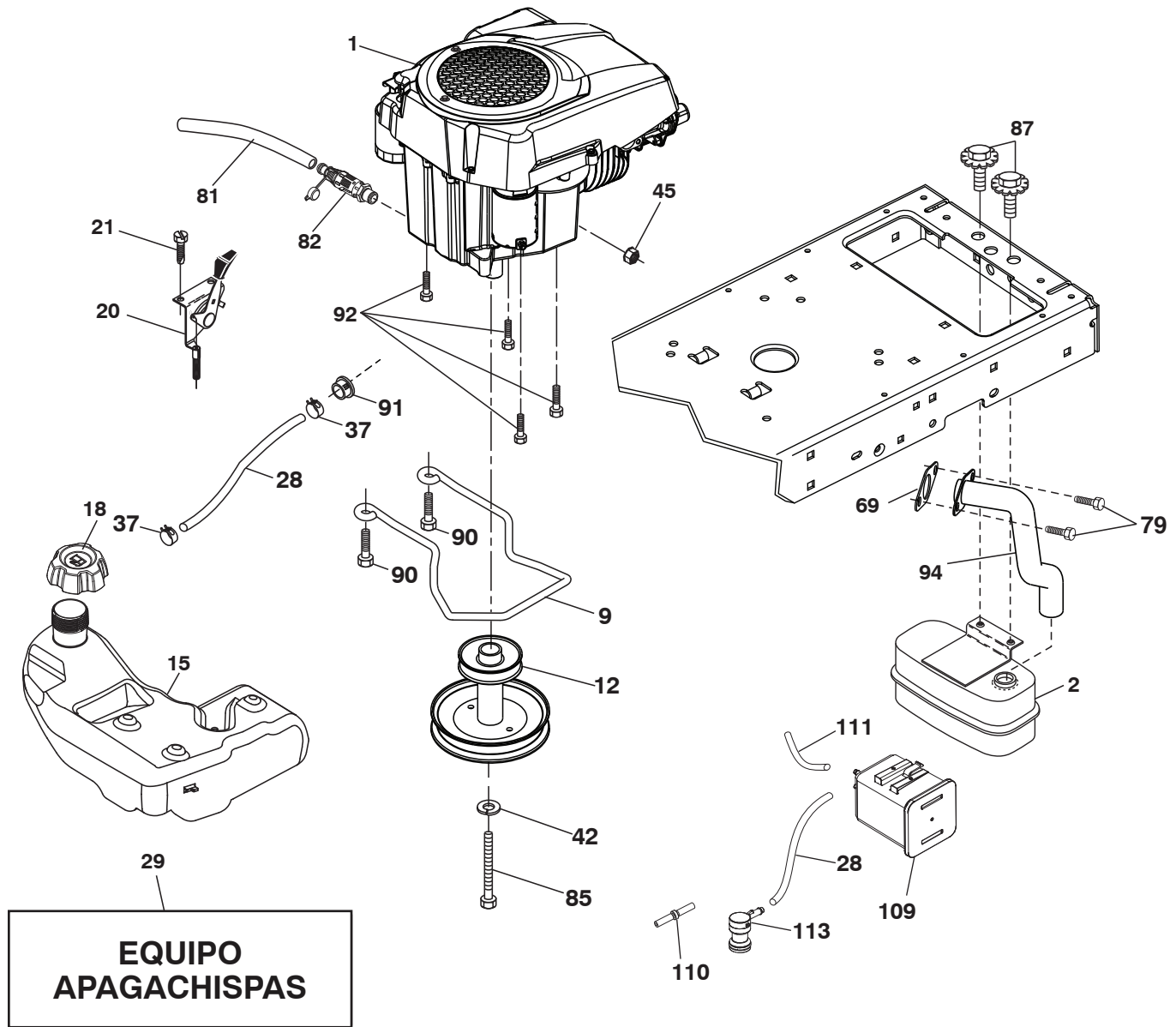

engine-tex_loncin_6_r1

**TRACTOR - - MODELO NO. YTH1942 (96043026700), PRODUCTO NO. 960 43 02-67
MOTOR**

CÓDIGO PIEZA		DESCRIPCIÓN
No.	No.	
1	593 23 01-01	Motor Husqvarna modelo No. HV 608CC Motor IPL disponible por separado.
2	590 64 53-01	Silenciador
9	501 83 26-02	Ensamble del sujetador de la correa del motor
12	586 47 85-01	Polea del motor
15	599 83 76-01	Depósito de combustible 3 galón
18	599 50 22-01	Ensamble de la tapa 3"
20	532 18 38-97	Control del regulador
21	596 32 17-01	Tornillo de #10 x 0.750
28	532 40 11-37	Línea de combustible
29	532 13 71-80	Equipo apagachispas
37	532 12 34-87	Abrazadera de la manguera
42	596 23 89-01	Arandela de 7/16"
45	593 35-64-01	Tuerca hexagonal con bridas
69	590 86 36-01	Junta
79	596 13 42-02	Tornillo de 5/16-18 x 1
81	532 14 84-56	Tubo de fácil drenaje de aceite
82	532 42 82-87	Conector del drenaje de aceite
85	501 60 65-01	Perno de 7/16-20 x 4 grado 5
87	532 17 18-77	Perno de 5/16-18 unc x 3/4 w/sems
90	817 00 06-16	Tornillo de 3/8-16 x 1
91	532 18 74-95	Buje
92	817 12 06-16	Tornillo de 3/8-16 x 1
94	590 86 48-01	Tubo de escape
109	532 41 41-14	Bote
110	532 41 41-18	Válvula
111	596 94 15-01	Línea de purga .1875"
113	532 41 41-27	Válvula

NOTA: Las dimensiones de todos los componentes están expresadas en pulgadas americanas. 1 pulgada = 25,4 mm

TRACTOR - - MODELO NO. YTH1942 (96043026700), PRODUCTO NO. 960 43 02-67
ENSAMBLE DE LA DIRECCIÓN

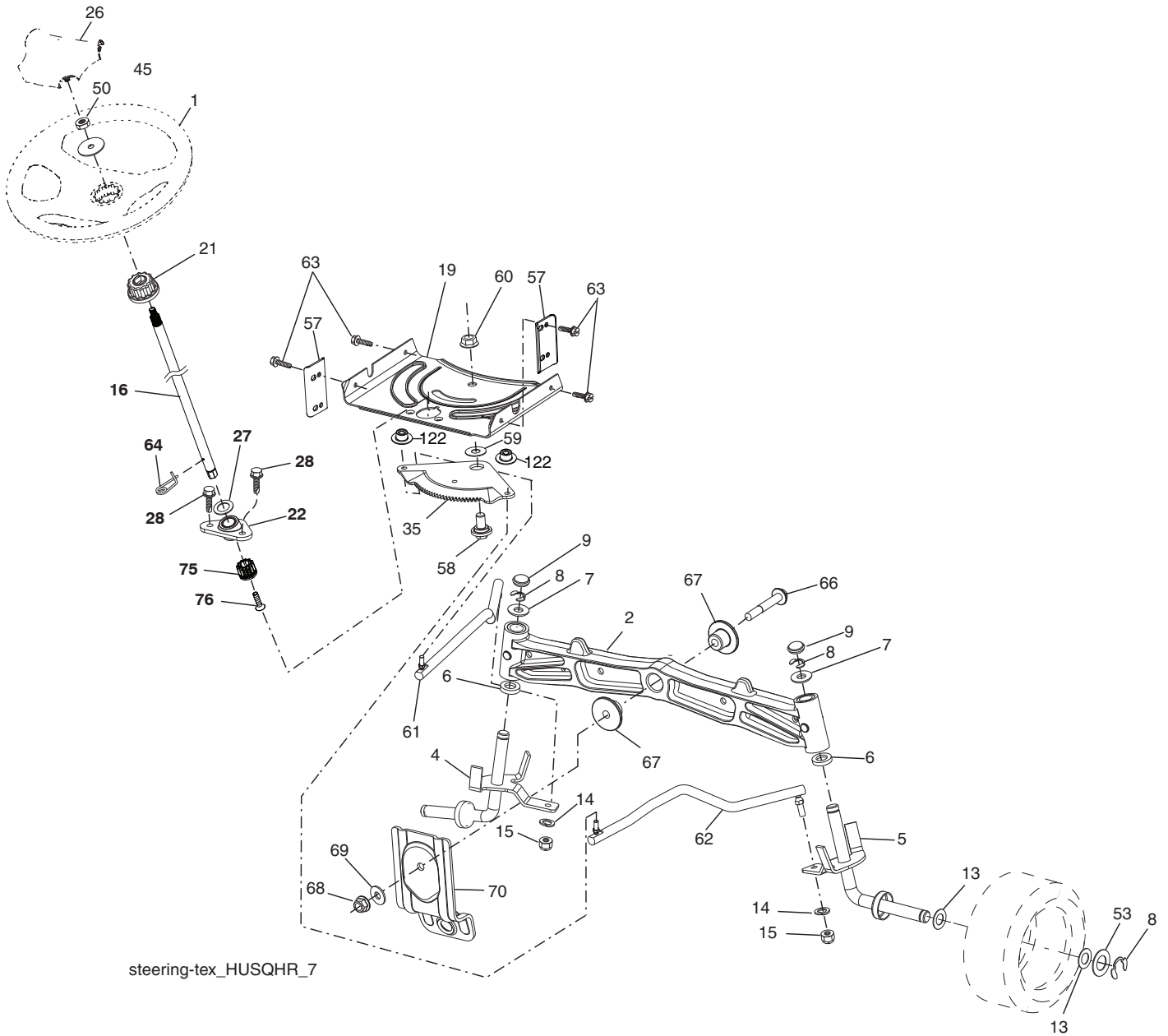

steering-tex_HUSQHR_7

**TRACTOR - - MODELO NO. YTH1942 (96043026700), PRODUCTO NO. 960 43 02-67
ENSAMBLE DE LA DIRECCIÓN**

CÓDIGO No.	PIEZA No.	DESCRIPCIÓN
1	532 43 97-40	Volante de dirección
2	532 19 59-68	Ensamble del eje delantero
4	532 40 30-87	Ensamble del husillo izquierdo
5	532 40 30-88	Ensamble del husillo derecho
6	532 00 62-66	Arandela de .75 x 1.230
7	532 12 17-48	Arandela de 25/32 x 1-5/8 calibre 16
8	812 00 00-29	Abrazadera del aro No. T5304-75
9	532 12 12-32	Tapa del husillo
13	532 12 17-49	Arandela de 25/32 x 1-1/4 calibre 16
14	596 23 87-01	Arandela de .381 x .680
15	873 54 06-00	Tuerca corona de presión de 3/8-24 unf
16	587 01 60-02	Eje de dirección
19	532 19 47-29	Placa de dirección
21	586 84 02-01	Adaptador del volante de dirección
22	585 02 98-02	Rodamiento
26	532 43 97-43	Inserto del volante de dirección
27	596 93 34-01	Arandela
28	817 00 06-12	Tornillo de 3/8-16 x 3/4
35	532 19 47-32	Engranaje del sector de la placa
45	587 01 64-01	Arandela 3/8 ID 2-3/8 OD calibre 12 PLTD
50	873 90 06-00	Tuerca 3/8-16 unc
53	532 18 89-67	Arandela reforzada de .793 x 1.637 x .060
57	532 40 74-65	Tope superior del soporte
58	532 19 47-47	Perno de tope del sector del pivote CFM
59	532 19 47-48	Arandela de empuje del sector de dirección
60	873 97 10-00	Tuerca de presión con brida de 5/8-11
61	597 07 02-02	Barra de acoplamiento izquierda
62	597 07 03-02	Barra de acoplamiento derecha
63	817 00 05-12	Tornillo de 5/16-18 x 3/4
64	532 19 98-49	Abrazadera de retención del resorte de la dirección
66	871 02 07-48	Perno de cabeza hexagonal con brida acanalada de 7/16-14 x 3
67	532 19 47-37	Buje PM del eje delantero
68	873 90 07-00	Tuerca de presión con brida de 7/16-14 grado 5
69	532 19 91-62	Arandela de 1.5 x .505 x .118
70	585 33 88-01	Soporte de la plataforma delantera
75	580 68 37-01	Piñón
76	580 68 36-01	Tornillo
122	532 44 49-62	Tapas

NOTA: Las dimensiones de todos los componentes están expresadas en pulgadas americanas. 1 pulgada = 25,4 mm

TRACTOR - - MODELO NO. YTH1942 (96043026700), PRODUCTO NO. 960 43 02-67
PLATAFORMA DE LA CORTADORA DE CÉSPED

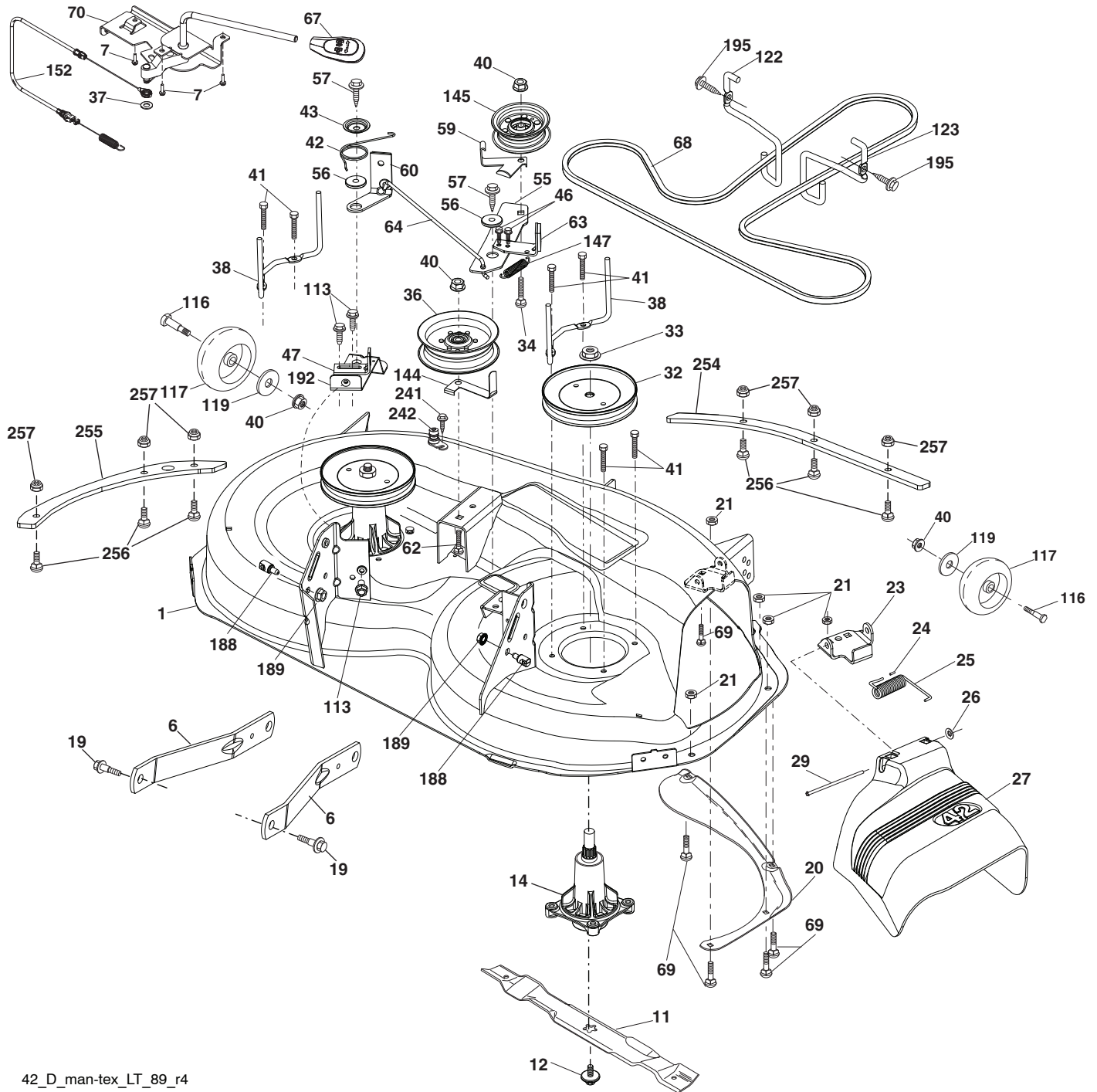

42_D_man-tex_LT_89_r4

**TRACTOR - - MODELO NO. YTH1942 (96043026700), PRODUCTO NO. 960 43 02-67
PLATAFORMA DE LA CORTADORA DE CÉSPED**

CÓDIGO PIEZA			CÓDIGO PIEZA		
No.	No.	DESCRIPCIÓN	No.	No.	DESCRIPCIÓN
1	532 44 78-95	Equipo de Carcasa de la cortadora de césped	62	596 13 63-01	Perno de 3/8-16 x 2
6	532 19 51-86	Brazo de la suspensión	63	532 19 94-77	Brazo del freno de la cortadora de césped
7	596 32 17-01	Tornillo de #10 x 0.750	64	532 19 99-18	Varillaje del freno
11	532 13 89-71	Cuchilla, 42" Hi-Lift (para empaquetar o descarga)	67	532 40 30-12	Manija del cable de embrague
12	584 30 93-01	Tornillo 7/16-20 x 1	68	532 42 96-36	Correa trapezoidal
14	587 81 97-01	Conjunto del mandril (incluye eje y perno)	69	596 13 64-01	Perno de 5/16-18 x 5/8
19	532 19 65-39	Perno de tope	70	532 19 99-72	Ensamble del embrague Manual
20	532 15 97-70	Deflector	113	817 00 05-10	Tornillo de 5/16-18
21	596 04 05-01	Tuerca de presión de 5/16-18	116	596 43 44-02	Perno de 2.41 x 1.66 x 5"
23	532 19 25-57	Soporte del deflector	117	589 52 74-01	Calibrador de la rueda
24	532 10 53-04	Tapa de la manga	119	596 13 49-01	Arandela de 3/8 x 7/8
25	532 19 70-26	Resorte de torsión del deflector	122	532 19 72-58	Sujetador izquierdo de la correa del motor
26	532 11 04-52	Tuerca de presión	123	532 19 72-59	Sujetador derecho de la correa del motor
27	532 40 30-04	Protector del deflector	144	532 19 92-04	Sujetador de la correa
29	595 29 70-01	Varilla de la bisagra	145	532 19 31-97	Polea loca primaria
32	532 19 74-73	Polea del mandril	147	532 40 19-71	Retorno del resorte
33	596 13 48-01	Tuerca de 9/16-18 x 1.010	152	584 24 35-01	Embrague Manual cable
34	596 13 61-01	Perno de 3/8-16 x 1-1/2	188	593 82 40-01	Perno prisionero con anti rotación
36	532 19 73-79	Polea loca	189	596 13 57-01	Tuerca de presión de 5/16-18 x .68
37	596 56 53-01	Rondelle 3/8 x 0.08	192	532 19 72-60	Soporte
38	589 67 61-02	Sujetador de la correa izquierda de mandril	195	817 00 06-12	Tornillo de 3/8-16 x 3/4
40	873 90 06-00	Tuerca de presión con brida de 3/8-16 unc	241	532 15 29-27	Tornillo No.10-32 5 3/8 con brida
41	584 95 39-01	Perno 313-18 x 1.19	242	532 41 55-98	Puerto De Lavado De La Cubierta
42	532 19 84-10	Resorte de torsión del freno	254	585 31 68-05	Placa frontal de refuerzo
43	532 19 72-56	Resorte de torsión del freno	255	585 31 70-05	Refuerzo de la placa 42"
46	532 13 77-29	Tornillo de 1/4-20 x 5/8	256	592 80 78-01	Perno de 1/4-20 x 1"
47	532 19 72-50	Soporte del cable de embrague	257	873 90 04-00	Tuerca de brida hexagonal 1/4-20 x 1
55	532 43 71-10	Brazo de la polea	--	532 41 64-05	Accesorio del conexión
56	532 19 90-92	Espaciador de retención	--	532 44 78-93	Reemplazo de la cortadora de césped, completa
57	817 00 06-16	Tornillo de 3/8-16 x 1			
59	532 14 10-43	Dispositivo de protección de la polea			
60	532 19 72-61	Brazo del freno de la cortadora de césped			

NOTA: Las dimensiones de todos los componentes están expresadas en pulgadas americanas. 1 pulgada = 25,4 mm

**TRACTOR - - MODELO NO. YTH1942 (96043026700), PRODUCTO NO. 960 43 02-67
ELEVACIÓN DE LA CORTADORA DE CÉSPED**

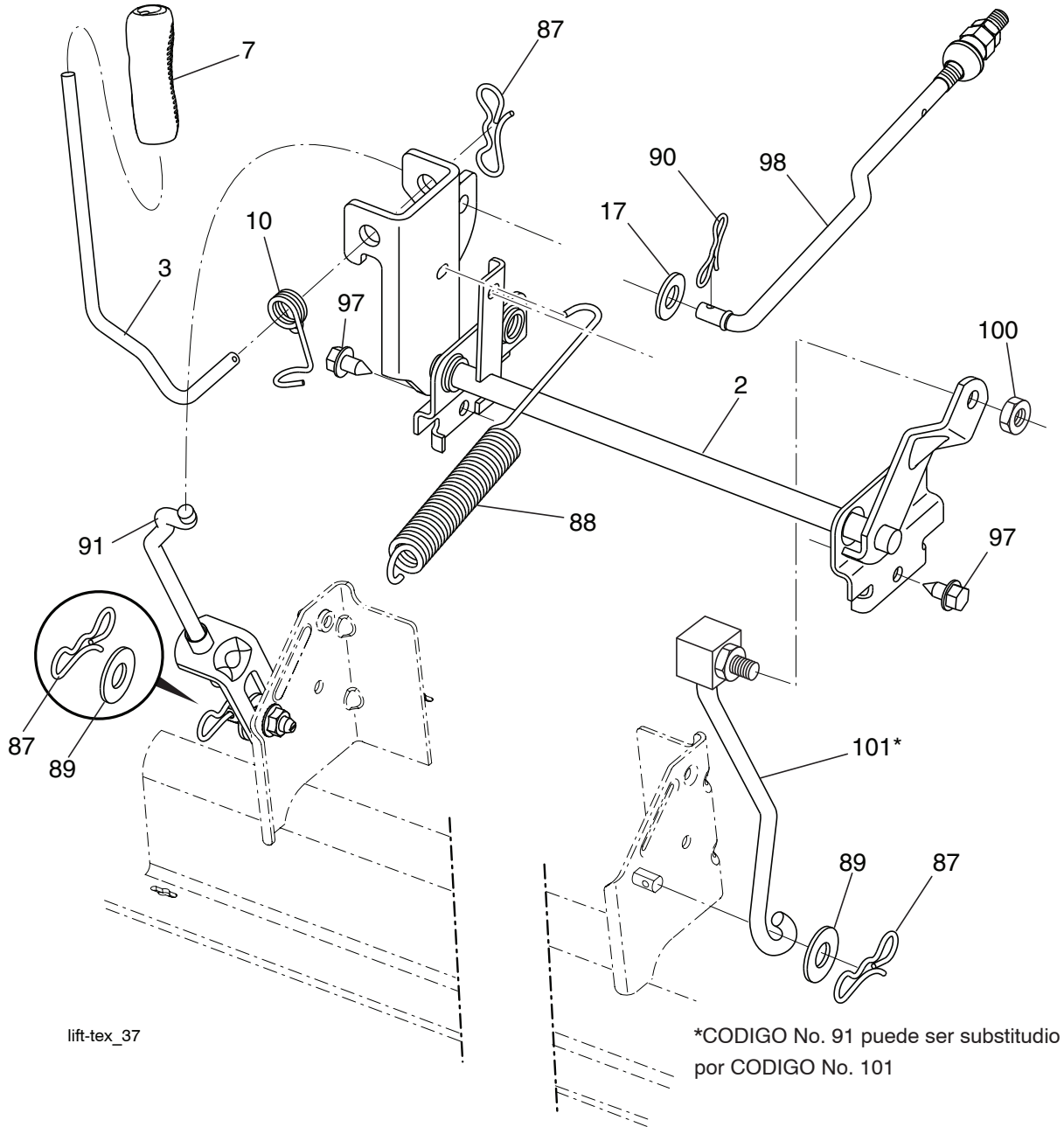

CÓDIGO No.	PIEZA No.	DESCRIPCIÓN
2	532 42 20-27	Ensamble del eje de la elevación
3	594 01 80-01	Ensamble de la palanca de elevación
7	580 96 23-01	Mango de la palanca
10	532 19 63-14	Resorte de torsión
17	594 97 65-01	Arandela de 15/32 x 15/16 x .065
87	532 19 42-09	Pasador de chaveta de 7/16 con bloqueo en forma de mariposa
88	532 41 07-10	Resorte de ayuda de la elevación
89	819 19 19-12	Arandela de zinc transparente
90	532 19 42-08	Pasador de chaveta de 5/16 con bloqueo en forma de mariposa

CÓDIGO No.	PIEZA No.	DESCRIPCIÓN
91	589 46 48-03	Ensamble del acoplamiento Elevación trasera
97	817 00 06-12	Tornillo de 3/8-16 x 3/4
98	581 50 69-03	Ensamble del acoplamiento Elevación Frente
100	595 30 59-01	Tuerca 3/8-16
101	532 40 70-03	Ensamble del acoplamiento Elevación fijo

NOTA: Las dimensiones de todos los componentes están expresadas en pulgadas americanas. 1 pulgada = 25,4 mm

**TRACTOR - - MODELO NO. YTH1942 (96043026700), PRODUCTO NO. 960 43 02-67
ENSAMBLE DEL ASIENTO**

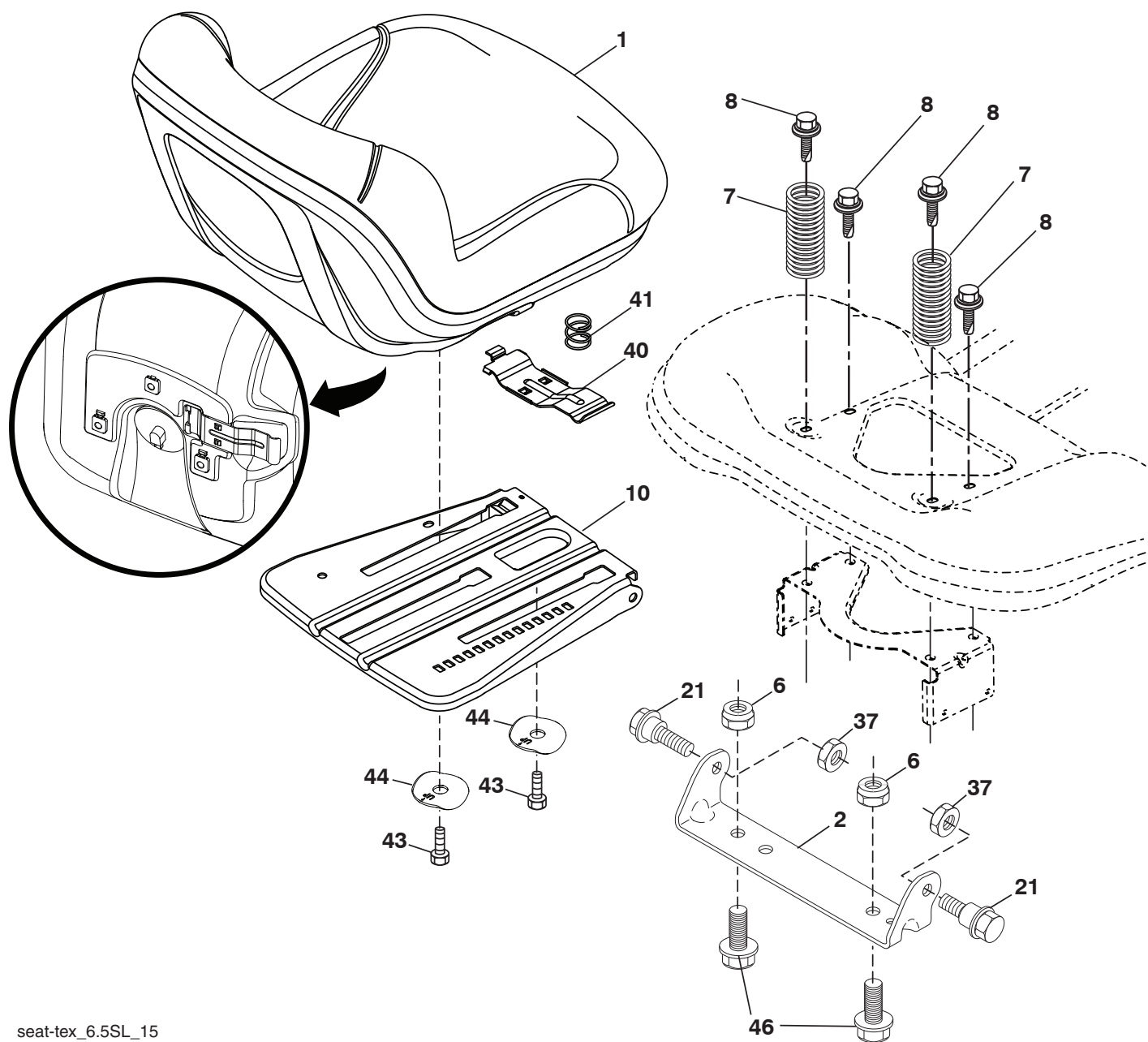

seat-tex_6.5SL_15

CÓDIGO PIEZA		DESCRIPCIÓN
No.	No.	
1	532 43 98-19	Asiento
2	532 18 01-66	Soporte pivotante del guardabarros
6	873 80 06-00	Tuerca de presión c/aislamiento de 3/8-16 unc
7	589 48 35-01	Resorte del asiento
8	532 17 18-77	Perno de 5/16" unc x 3/4"
10	596 65 74-02	Diapositiva de la placa de asiento
21	587 90 78-01	Perno de 5/16-18 x 5/8
37	596 58 37-02	Tuerca hexagonal 5/16-18

CÓDIGO PIEZA		DESCRIPCIÓN
No.	No.	
40	595 08 81-02	Manija para deslizar el asiento
41	532 19 82-00	Resorte para trabar el asiento
43	874 76 06-12	Perno de cabeza hexagonal con aleta de 3/8-16 unc x 3/4
44	501 05 18-01	Arandela
46	588 09 04-01	Perno 3/8-16 x 1, 1.25

NOTA: Las dimensiones de todos los componentes están expresadas en pulgadas americanas. 1 pulgada = 25,4 mm

**TRACTOR - - MODELO NO. YTH1942 (96043026700), PRODUCTO NO. 960 43 02-67
CALCOMANÍAS**

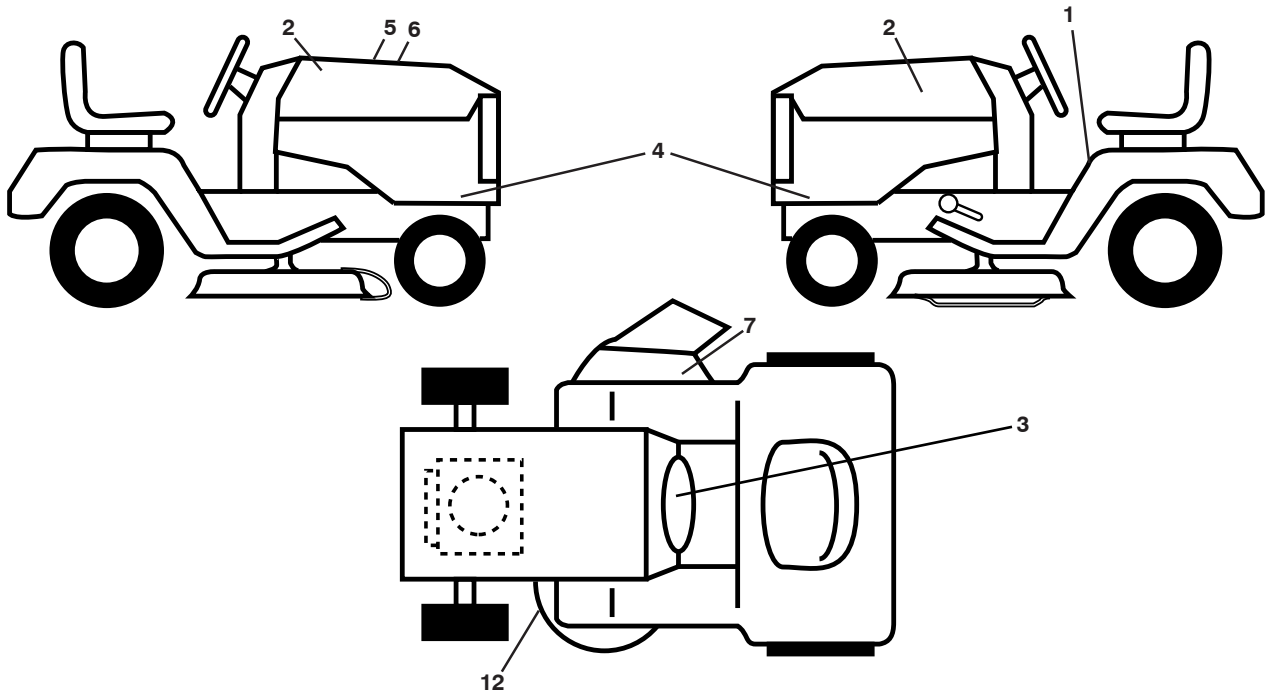

**CÓDIGO PIEZA
No. No.**

DESCRIPCIÓN

1	581 57 89-01	Calcomanía para el guardabarros del operador
2	501 13 14-01	Calcomanía para la capota logotipo
3	596 02 42-01	Calcomanía advertencia equipo apagachispas
4	592 88 89-01	Calcomanía tablero lateral
5	532 42 38-29	Calcomanía del cliente
6	592 87 71-01	Calcomanía de reemplazo
7	584 90 46-01	Calcomanía, Advertencia
12	581 58 00-01	Calcomanía del diagrama de la cortadora de césped correa trapezoidal

**CÓDIGO PIEZA
No. No.**

DESCRIPCIÓN

--	581 72 48-01	Calcomanía para la desviación
--	532 43 96-81	Forro del apoyo para los pies (LI)
--	532 43 96-82	Forro del apoyo para los pies (LD)
--	115 94 97-49	Manual de Operario (Español/ Inglés)
--	115 94 98-49	Manual De Repuestos (Español/ Inglés)
-	587 71 00-26	Guía de inicio rápido (Español/ Inglés)

RUEDAS Y NEUMÁTICOS

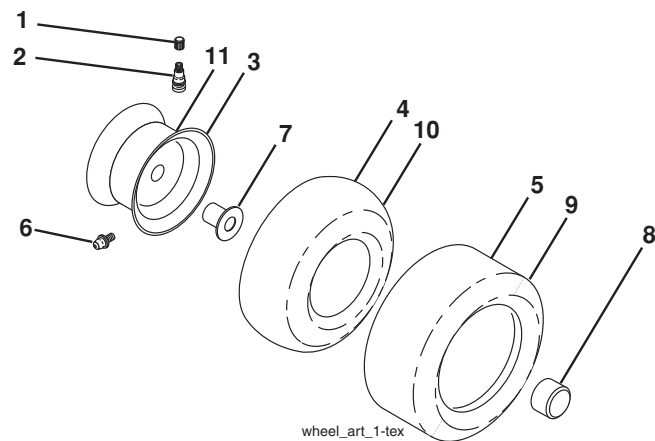

**CÓDIGO PIEZA
No. No.**

DESCRIPCIÓN

1	532 05 91-92	Tapa de la válvula del neumático
2	532 06 51-39	Vástago de la válvula
3	532 13 83-36	Ensamble de las llantas delanteras 6 pulgada
4	532 05 99-04	Cámara delantera (Mantenimiento sólo)
5	532 10 62-22	Neumático delantero de 15 x 6-6
6	532 00 02-78	Accesorio para engrasar
7	532 00 90-40	Rodamiento de la brida
8	532 17 50-39	Tapa del eje
9	532 13 84-68	Neumático trasero de 20 x 8-8
10	532 00 71-52	Cámara trasera (Mantenimiento sólo)
11	532 13 83-37	Ensamble trasero de la llanta 8 pulgada
--	532 14 43-34	Sellador para neumáticos (tubo de 10 onzas [283 gr])

NOTA: Las dimensiones de todos los componentes están expresadas en pulgadas americanas. 1 pulgada = 25,4 mm

NOTES/AVISO



www.husqvarna.com