

Repair Parts Manual
Manual De Repuestos
TS354XD / 96043024500

Please read the operator's manual carefully and make sure you understand the instructions before using the machine.

Por favor lea cuidadosamente y comprenda estas instrucciones antes de usar esta maquina.



English/Spanish

115 99 44-49 Rev. 13



HOW TO USE THIS MANUAL

This manual is designed to provide the customer with a means to identify the parts on his/her tractor when ordering repair parts. The illustrations may or may not represent the actual assemblies; therefore, it is not recommended to use this manual as a guide to assemble or disassemble the tractor. Some hardware and parts are drawn larger in order to more readily identify them.

Each tractor has its own model number. The model number for your tractor can be found on the fender under the seat.

Support / Help

If you require assistance or have questions concerning the application, operation, maintenance or parts for your product:

- Visit our website: www.husqvarna.com
- Call Us Toll Free: 1-800-487-5951

When ordering parts, always give the following information:

- Product - "TRACTOR"
- MODEL NUMBER - "TS354XD" (96043024500)"
- Part Number
- Part Description

TABLE OF CONTENTS

SCHEMATIC	3
ELECTRICAL	4-5
CHASSIS	6-7
DRIVE	8-9
ENGINE	10-11
STEERING	12-13
MOWER DECK	14-15
MOWER LIFT	16
SEAT	17
DECALS	18

COMO UTILIZAR ESTE MANUAL

Este manual está diseñado para brindarle al comprador un medio para identificar las piezas del tractor para cuando necesite hacer el pedido de un repuesto. Las ilustraciones pueden o no representar los ensambles reales; por lo tanto, no se recomienda utilizar este manual como una guía para ensamblar o desarmar el tractor. Algunos accesorios y piezas están dibujados en tamaños más grandes para identificarlos con mayor facilidad.

Cada tractor tiene su propio número de modelo. El número de modelo del tractor se encuentra en el guardabarros debajo del asiento.

Soporte / Ayuda

Si necesita asistencia o tiene alguna pregunta acerca de la aplicación, operación, mantenimiento o piezas de su producto:

- Visite nuestro sitio web: www.husqvarna.com
- Llámenos de manera gratuita al: 1-800-487-5951

Cuando haga el pedido de una pieza, siempre brinde la siguiente información:

- Producto: "TRACTOR"
- NÚMERO DE MODELO:"TS354XD" (96043024500)"
- Número de pieza
- Descripción de la pieza

ÍNDICE

DIAGRAMA	19
DIAGRAMA ELÉCTRICO	20-21
CHASIS	22-23
TRANSMISIÓN	24-25
MOTOR	26-27
DIRECCIÓN	28-29
PLATAFORMA DE LA CORTADORA DE CÉSPED	30-31
ELEVACIÓN DE LA CORTADORA DE CÉSPED	32
ASIENTO	33
CALCOMANÍAS	34

TRACTOR - MODEL NO. TS 354XD (96043024500), PRODUCT NO. 960 43 02-45 SCHEMATIC

SCH27

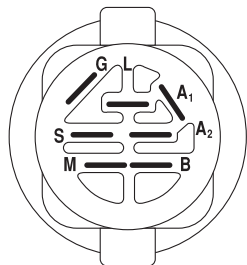
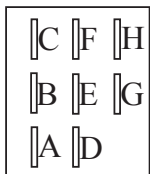
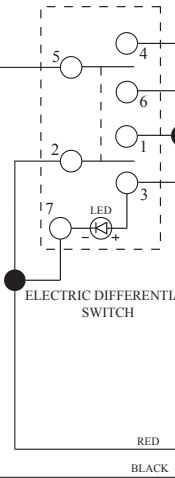
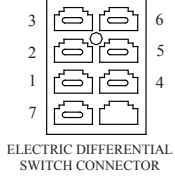
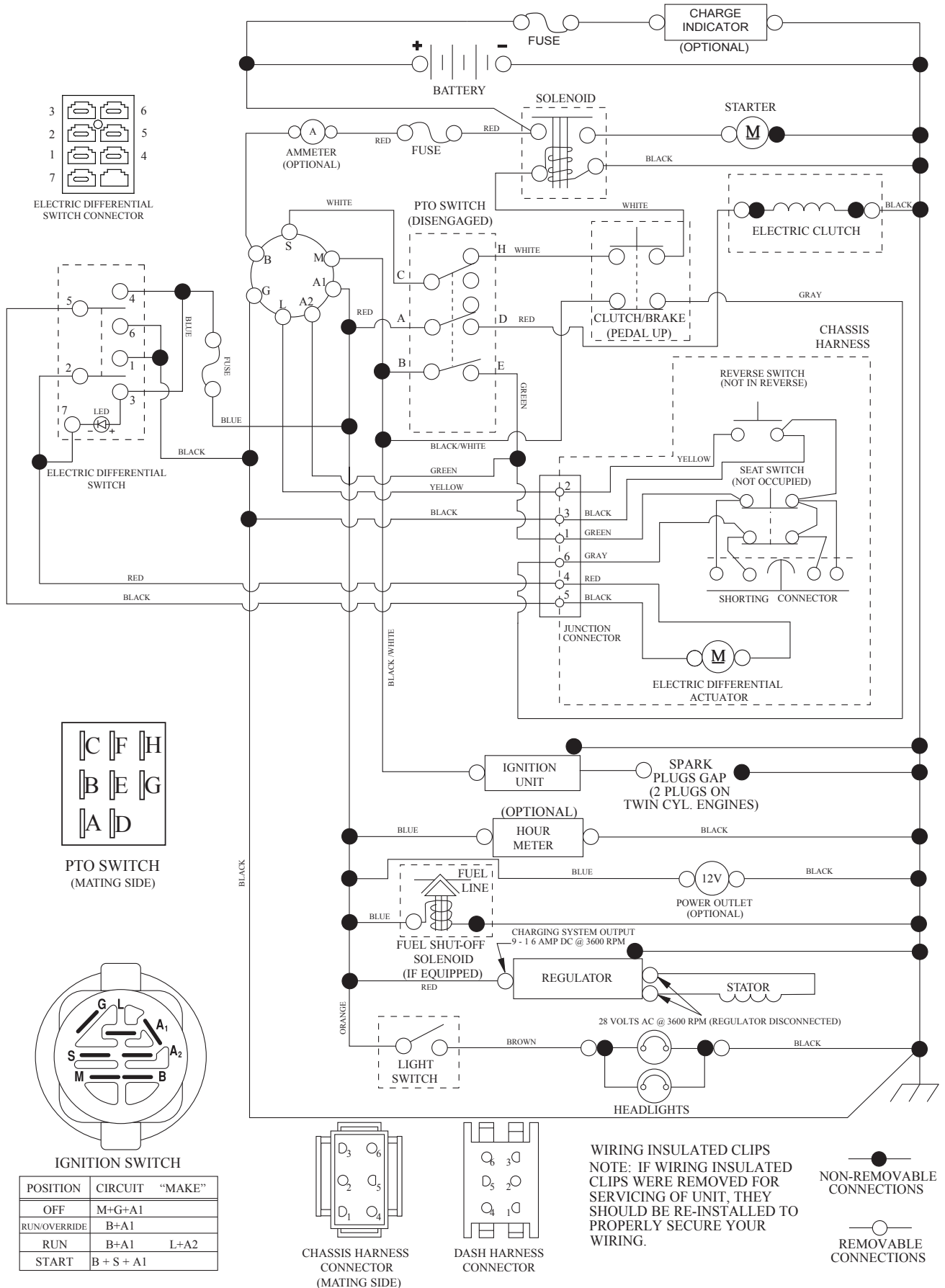

POSITION	CIRCUIT "MAKE"
OFF	M+G+A1
RUN/OVERRIDE	B+A1
RUN	B+A1 L+A2
START	B + S + A1

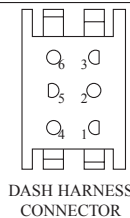

**TRACTOR - MODEL NO. TS 354XD (96043024500), PRODUCT NO. 960 43 02-45
ELECTRICAL**

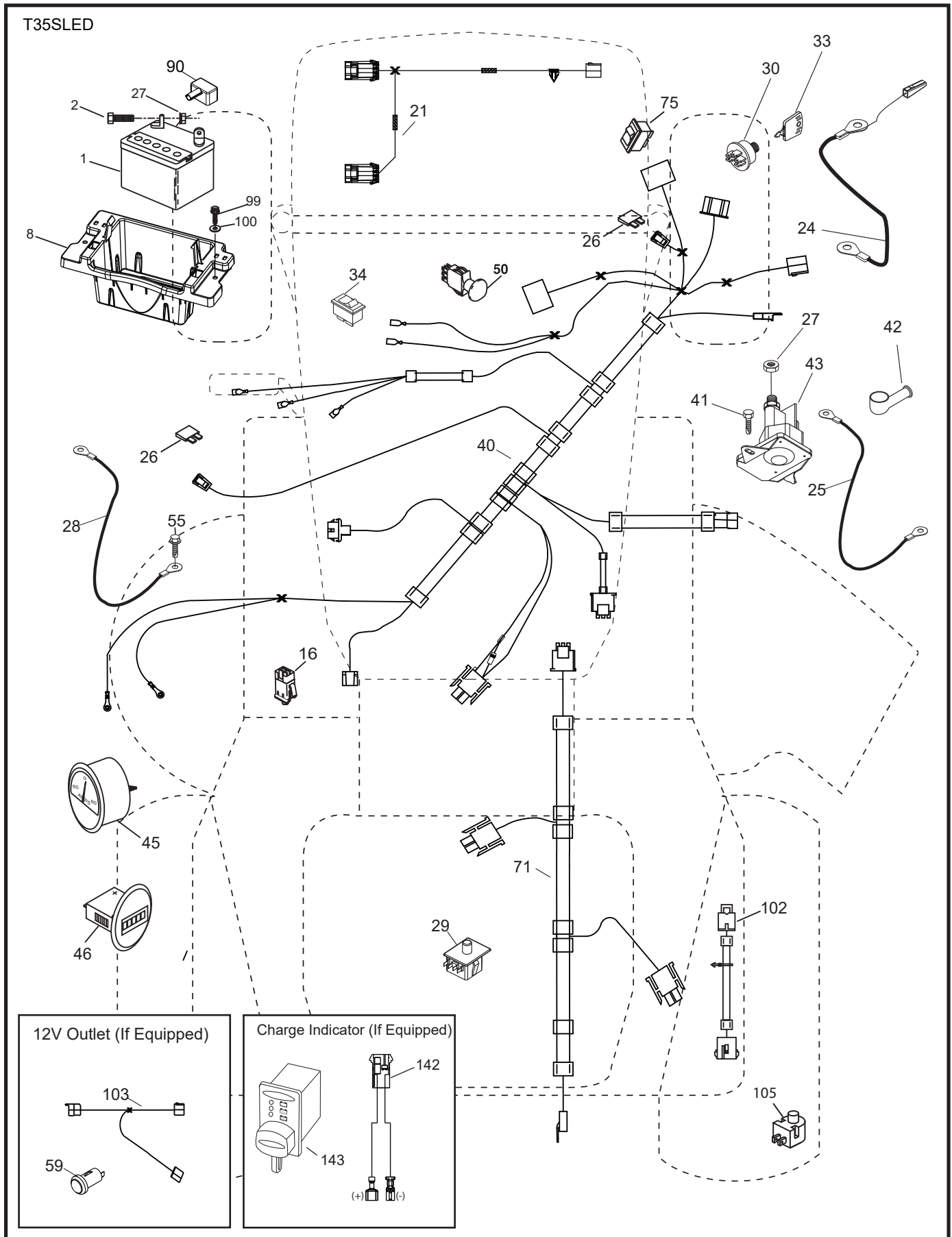

**TRACTOR - MODEL NO. TS 354XD (96043024500), PRODUCT NO. 960 43 02-45
ELECTRICAL**

KEY NO.	PART NO.	DESCRIPTION
1	532 16 34-65	Battery
2	874 76 04-12	Bolt Hex Hd 1/4-20 unc x 3/4
8	587 20 51-01	Battery Box
16	532 17 61-38	Switch Interlock
21	585 43 64-01	Harness Light
24	585 55 56-01	Cable Battery
25	585 55 55-01	Cable Starter
26	532 17 51-58	Fuse
27	873 51 04-00	Nut Keps Hex 1/4-20 unc
28	532 41 65-88	Cable Ground 21" Blk
29	532 19 27-49	Switch Seat
30	532 19 33-50	Switch Ign
33	532 41 19-35	Key/Chain
34	532 11 07-12	Switch Light/Reset
40	501 13 36-01	Harness Ign. Dash
41	817 72 04-08	Screw 1/4-20 unc x 1/2
42	532 13 15-63	Cover Terminal Red
43	582 04 28-01	Solenoid
45	587 55 39-03	Gauge Ammeter
46	587 55 40-03	Hourmeter
50	582 10 76-01	Switch PTO
55	817 06 05-12	Screw Thdrol 5/16-18 x 3/4
71	580 51 30-01	Harness Ign Chassis
75	580 36 64-01	Switch On/On
90	532 43 53-95	Cover Terminal Battery
99	817 67 04-12	Screw Hexwsh Thdrol 1/4-20 x 3/4
100	819 09 14-16	Washer 9/32 x 7/8 x 16 Ga.
102	532 40 44-54	Harness Pigtail
105	532 40 75-68	Switch Reverse
142	583 85 78-01	Charge Port Plgtail
143	532 44 80-59	Charge Port

NOTE: All component dimensions given in U.S. inches
1 inch = 25.4 mm

**TRACTOR - MODEL NO. TS 354XD (96043024500), PRODUCT NO. 960 43 02-45
CHASSIS**

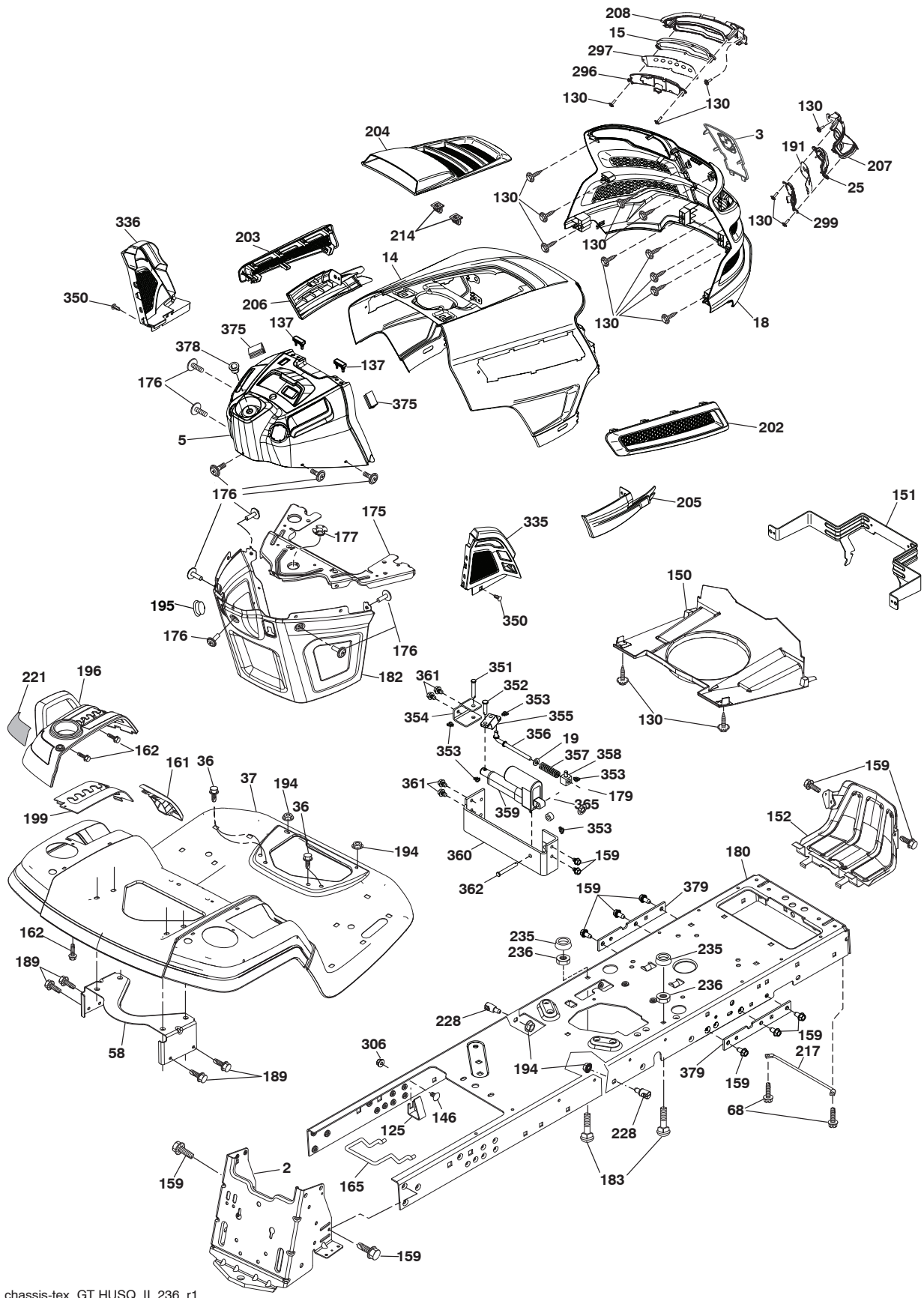

chassis-tex_GT HUSQ_II_236_r1

**TRACTOR - MODEL NO. TS 354XD (96043024500), PRODUCT NO. 960 43 02-45
CHASSIS**

KEY NO.	PART NO.	DESCRIPTION
2	580 43 44-01	Drawbar
3	532 44 44-81	Logo Husq.
5	590 74 00-22	Dash
14	532 44 11-77	Hood
15	585 42 03-01	Lens LH
18	587 52 34-01	Grille
19	819 13 13-12	Washer 13/32 x 13/16 x 12 Ga.
25	585 42 02-01	Lens RH
36	817 06 05-12	Screw 5/16-18 x 3/4
37	532 44 12-08	Fender
58	532 19 43-14	Bracket Fender
68	539 99 08-58	Screw 5/16-18 x 1/2
125	581 68 48-01	Clip Fuel Line
130	532 41 63-58	Screw #10 x 0.750 BOS Thread
137	532 40 75-90	Bumper Dash
146	581 85 79-01	Bolt
150	532 43 97-74	Duct Heat Hood
151	532 43 66-70	Bracket Pivot Hood
152	532 43 98-70	Shield Browning
159	817 00 06-12	Screw 3/8-16 x 3/4
162	532 14 24-32	Screw Hex Wsh Hi-Lo 1/4 x 1/2
161	532 43 99-29	Fuel Window
165	532 19 43-30	Bracket Support Tank
175	590 60 77-02	Crossmember
176	532 40 07-76	Screw 10-24 x 5/8 Wshd Qdrx
177	532 19 52-28	Bushing Steering
179	532 16 89-37	Nut Push
180	593 34 63-01	Chassis
182	532 40 68-59	Dash Lower
183	874 52 05-20	Bolt 5/16-18 x 1-1/4
189	817 00 05-12	Screw 5/16-18 x 3/4
191	586 18 28-01	Insert Reflect. RH
194	873 90 05-00	Nut Lock Hex Flange 5/16-18
195	532 40 41-37	Plug Hole Dash
196	532 43 96-74	Console Asm. Deck Lift
199	532 19 82-59	Plate Deck Lift
202	532 43 97-28	Vent Side Hood RH
203	532 43 97-27	Vent Side Hood LH

KEY NO.	PART NO.	DESCRIPTION
204	532 44 44-84	Vent Asm Hood Top
205	532 43 97-30	Skirt Hood Side RH
206	532 43 97-29	Skirt Hood Side LH
207	585 42 00-02	Bezel RH
208	585 42 01-02	Bezel LH
214	532 19 91-45	Clip Retainer
217	532 40 91-67	Rod Pivot
221	532 19 89-09	Reflector LH
228	532 19 51-61	Stud Fastener
235	532 40 61-29	Spacer Fender
236	873 93 05-00	Nut Center Lock 5/16-18 unc
296	585 42 05-01	LED Light LH
297	586 18 29-01	Insert Reflect. LH
299	585 42 04-01	LED Light RH
306	873 90 06-00	Nut Lock
335	532 44 82-04	Cover RH Lower
336	532 44 53-09	Cover LH Lower
350	532 44 51-43	Clip X-mas Tree
351	532 42 17-34	Pin Clevis .375 x 2.125
352	532 44 86-34	Clevis .375 x 2.125
353	532 17 80-62	Clip Retainer .0375
354	532 44 86-19	Support Bellcrank
355	532 44 86-36	Bellcrank Pivot Lock Diff
356	532 44 86-93	Link Lock Diff
357	532 44 86-84	Spring Compression
358	580 36 66-01	Swivel Guide
359	584 39 34-01	Actuator Electric
360	532 44 86-18	Bracket Actuator
361	817 49 06-10	Screw Hxwsh Thdr 3/8-16 x 5/8
362	532 44 86-33	Clevis .375 x 2.42
365	532 44 73-68	Nylon Spacer .375 x .4375L
375	586 90 82-01	Dash Clip-On Bumper
378	590 84 98-01	Bushing Flange
379	593 20 69-02	Chassis Plate Reinforcement
--	532 43 18-82	Kit Guard Brush

NOTE: All component dimensions given in U.S. inches
1 inch = 25.4 mm

TRACTOR - MODEL NO. TS 354XD (96043024500), PRODUCT NO. 960 43 02-45
DRIVE

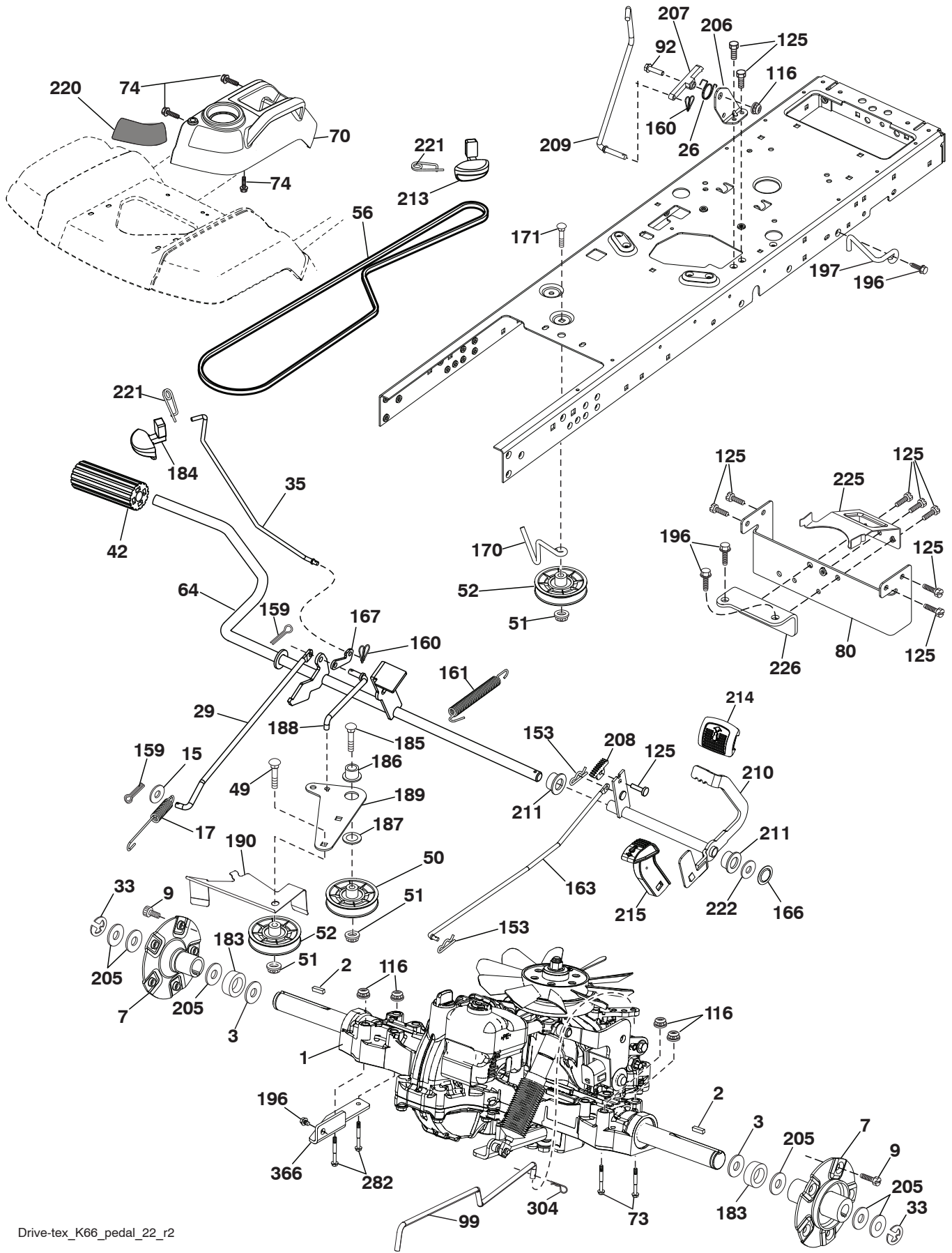

Drive-tex_K66_pedal_22_r2

**TRACTOR - MODEL NO. TS 354XD (96043024500), PRODUCT NO. 960 43 02-45
DRIVE**

KEY NO.	PART NO.	DESCRIPTION	KEY NO.	PART NO.	DESCRIPTION
1	---	Transaxle, Tufftorq K66ELD (580402201)(Order parts from transaxle manufacturer.)	167	532 40 52-57	Latch Brake Parking
2	539 91 27-57	Key .25 x 1.25	170	532 19 43-22	Keeper V-Idler Centerspan
3	532 00 75-63	Washer Thrust Axle Hardened	171	872 11 06-16	Bolt 3/8-16 x 2.00 Carriage
7	586 93 54-02	Hub Asm. Wheel	183	587 58 74-01	Spacer
9	532 14 00-80	Bolt Hub Wheel	184	587 65 37-01	Handle Parking Brake
15	819 13 13-16	Washer 13/32 x 13/16 x 16 Ga.	185	872 11 06-22	Bolt Rdhd 3/8-16 unc x 2-3/4 G5
17	532 40 10-72	Spring, Brake	186	532 19 43-21	Spacer Retainer
26	532 19 96-79	Spring Return Cruise	187	819 13 32-10	Washer
29	532 40 72-45	Rod, Brake	188	582 21 70-01	Link Clutch Ground Drive Long
33	812 00 00-53	Ring E	189	532 19 43-17	Bellcrank Ground Drive
35	590 60 59-01	Rod, Brake, Park	190	532 19 43-18	Keeper Bellcrank Ground Drive
42	532 12 48-72	Cover, Foot Pedal	196	817 00 06-16	Screw 3/8-16 x 1
49	872 11 06-14	Bolt 3/8-16 x 1-3/4 Carriage	197	585 65 86-01	Bracket Clutch Anti-Rotation
50	532 19 43-27	Pulley Idler Flat	205	532 12 38-00	Washer 1-1/32 x 1-5/8 x 16 Ga.
51	873 90 06-00	Lock Nut 3/8-16	206	532 44 85-96	Bracket Mount Latch Cruise
52	532 19 43-26	Idler V-Groove	207	587 03 14-01	Latch Control Cruise
56	592 85 53-01	V-Belt, Drive	208	532 19 78-69	Gear Sector Control Cruise
64	532 19 78-65	Shaft Asm. Pedal Brake Control	209	590 52 78-01	Rod Control Cruise
70	532 43 96-61	Console Asm	210	532 19 78-60	Rocker Asm. Pedal Control
73	874 49 05-44	Bolt Hex Flghd 5/16-18 Gr. 5	211	532 12 01-83	Bearing Nylon
74	532 14 24-32	Screw 1/4 x 1/2	213	532 40 31-19	Knob Control Cruise
80	589 33 34-02	Strap Torque	214	532 42 12-63	Pedal Forward
92	874 76 05-20	Bolt 5/16-18 x 1/2	215	586 60 65-02	Pedal Reverse
99	582 40 47-01	Spring Bypass	220	532 19 89-08	Reflector RH
116	873 90 05-00	Nut Lock Hex Flange 5/16-18	221	532 40 31-87	Retainer Spring Clip Handle
125	817 00 05-12	Screw 5/16-18 x 3/4	222	879 21 20-10	Washer 21/32 x 1-1/4 x 10 Ga.
153	532 12 47-88	Retainer Spring	225	532 40 73-11	Keeper Belt
159	876 02 04-12	Pin Cotter 1/8 x 3/4	226	532 40 71-09	Bracket Mount Torque
160	532 16 94-84	Retainer Clip	282	874 49 05-48	Bolt 5/16-18 x 3.0 G5
161	532 10 57-09	Spring, Return, Clutch	304	532 42 33-03	Pin
163	532 40 72-46	Rod Pedal Control	366	580 62 62-01	Bracket Reinforcement
166	532 42 91-64	Nut Push .625			

NOTE: All component dimensions given in U.S. inches
1 inch = 25.4 mm

**TRACTOR - MODEL NO. TS 354XD (96043024500), PRODUCT NO. 960 43 02-45
ENGINE**

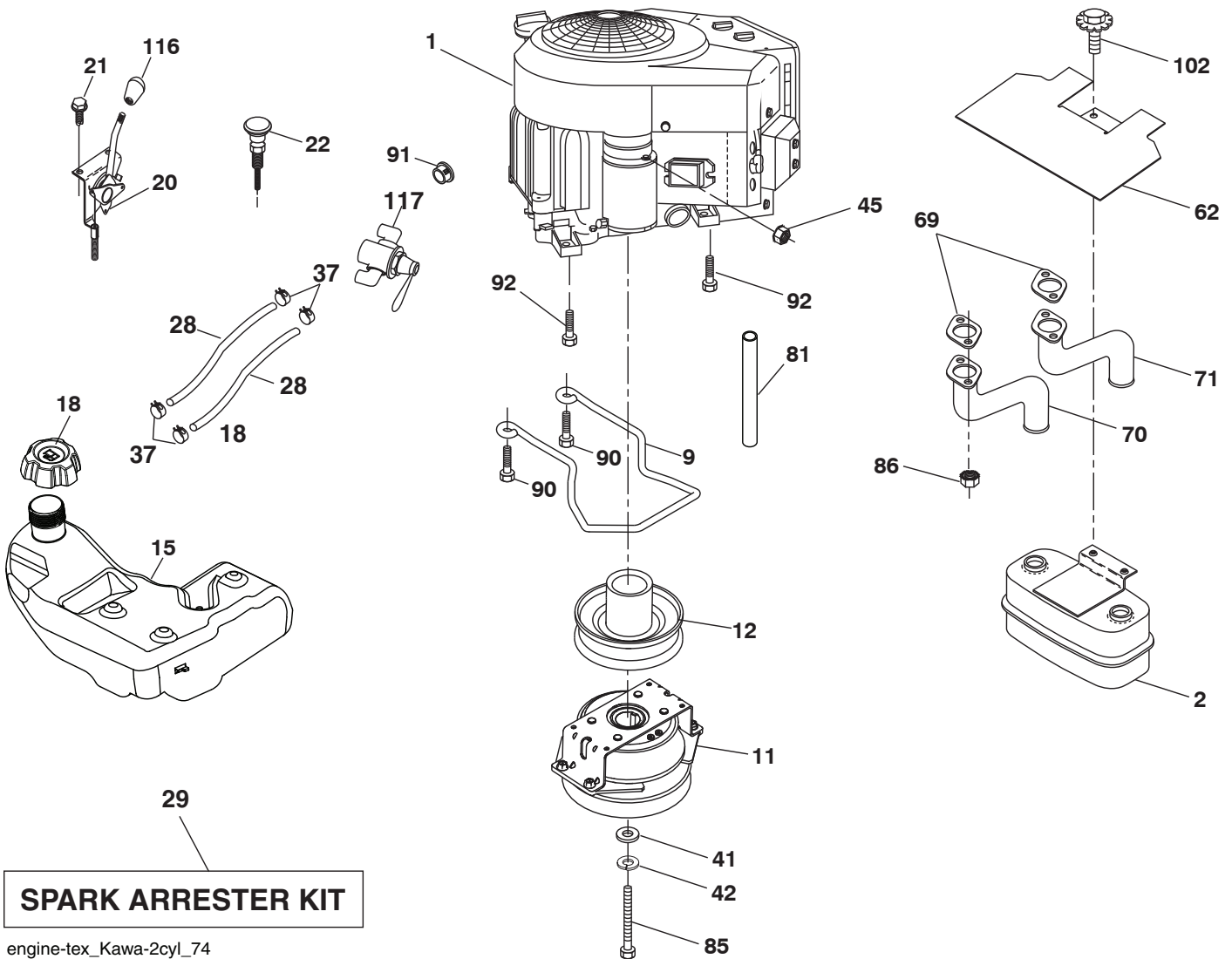

**TRACTOR - MODEL NO. TS 354XD (96043024500), PRODUCT NO. 960 43 02-45
ENGINE**

KEY NO.	PART NO.	DESCRIPTION
1	-- -- -- --	Engine KAWA Model No. FR730V-ES04 (445363)(Order parts from engine manufacturer.)
2	589 81 87-01	Muffler
9	501 83 26-01	Keeper Asm. Belt Engine
11	587 24 14-01	Clutch Electric
12	532 19 43-43	Pulley Engine
15	532 43 80-22	Tank Fuel
18	585 12 48-01	Cap Asm
20	532 42 43-41	Control Throttle
21	532 41 63-58	Screw #10 x 0.750 BOS Thread
22	532 19 15-96	Control Choke
28	587 04 48-61	Fuel Line
29	532 13 71-80	Spark Arrester Kit
37	532 12 34-87	Clamp Hose
41	532 12 61-97	Washer 1-1/2 OD x 15/32 ID x .250
42	539 99 02-47	Washer SLW STD 7/16
45	873 51 04-00	Nut Keps Hex 1/4-20 unc
62	532 43 40-17	Shield Heat Muffler
69	532 17 81-51	Gasket
70	583 95 56-01	Tube Exhaust LH
71	583 95 57-01	Tube Exhaust RH
81	532 14 84-56	Oil Tube Drain
85	501 60 69-01	Bolt 7/16-20 x 3.0 x Gr. 5
86	532 18 43-62	Nut Hex M8-1.25
90	817 00 06-16	Screw 3/8-16 x 1
91	532 18 74-95	Bushing
92	817 12 06-16	Screw 3/8-16 x 1
102	817 00 05-12	Screw 5/16 x 3/4
116	539 13 26-24	Knob Soft Touch
117	532 42 08-28	Valve Fuel Reserve

NOTE: All component dimensions given in U.S. inches
1 inch = 25.4 mm
For engine service and replacement parts, call the toll free number for your engine manufacturer listed below:

Kawasaki 1-949-460-5688

**TRACTOR - MODEL NO. TS 354XD (96043024500), PRODUCT NO. 960 43 02-45
STEERING ASSEMBLY**

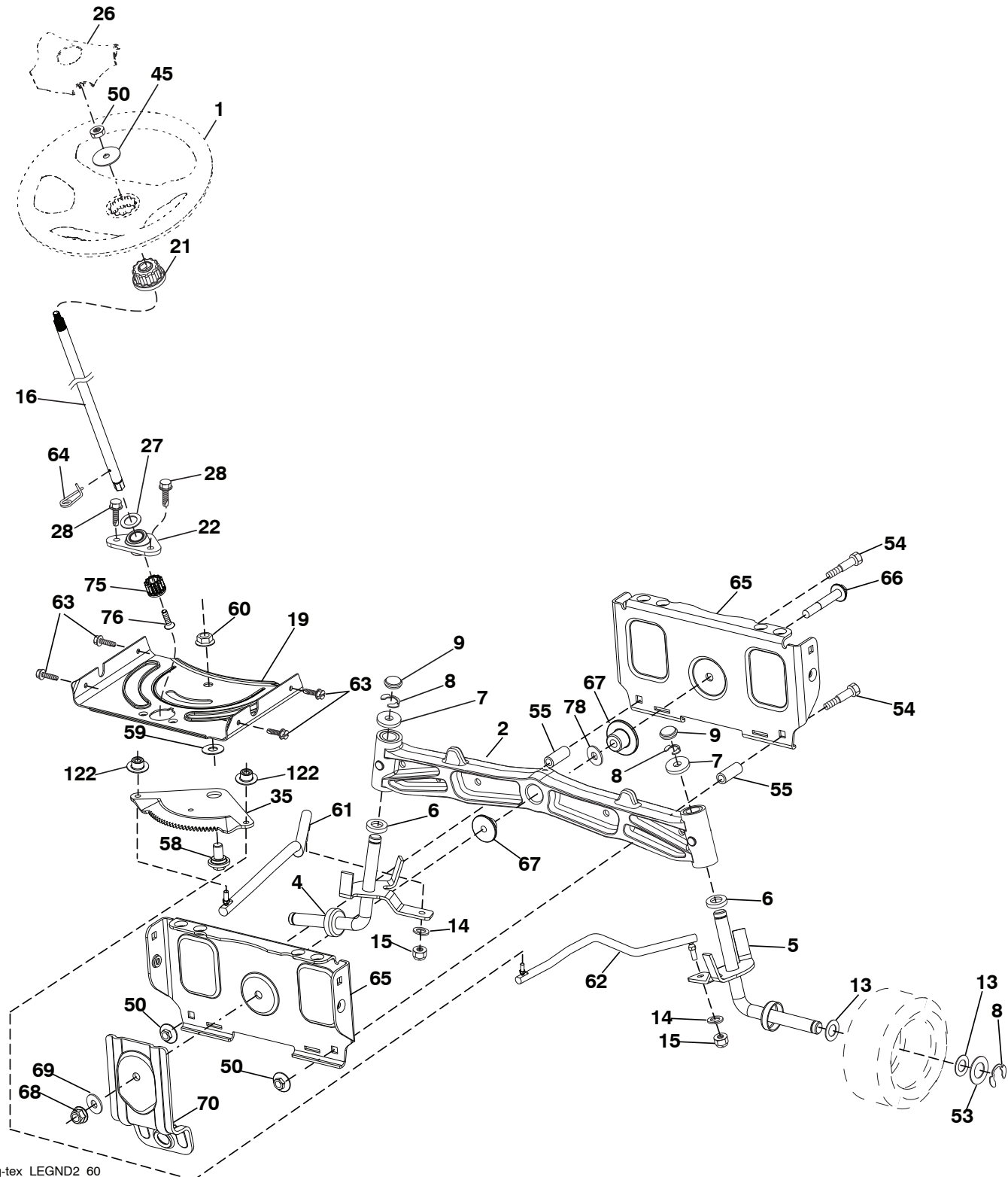

Steering-tex_LEGND2_60

**TRACTOR - MODEL NO. TS 354XD (96043024500), PRODUCT NO. 960 43 02-45
STEERING ASSEMBLY**

KEY NO.	PART NO.	DESCRIPTION
1	532 43 97-40	Wheel, Steering
2	532 19 59-68	Axle Asm., Front
4	532 40 30-89	Spindle Asm. LH
5	532 40 30-90	Spindle Asm. RH
6	532 12 49-31	Bearing, Race Thrust Harden
7	532 12 17-48	Washer 25/32 x 1-5/8 x 16 Ga.
8	812 00 00-29	Ring, Clip #T5304-75
9	532 12 12-32	Cap, Spindle
13	532 12 17-49	Washer 25/32 x 1-1/4 x 16 Ga.
14	539 99 01-18	Washer, SLW STD 3/8
15	873 54 06-00	Nut, Crown Lock 3/8-24 unf
16	587 01 60-02	Steering Shaft
19	532 19 47-29	Plate Steering
21	586 84 02-01	Adapter Wheel Steering
22	585 02 99-01	Bearing
26	532 43 97-43	Insert, Wheel Steering
27	819 21 16-16	Washer
28	817 00 06-12	Screw 3/8-16 x 3/4
35	532 19 47-32	Gear, Sector Plate
45	587 01 64-01	Washer 3/8 ID 2-3/8 OD 12 Ga. PLTD
50	873 90 06-00	Nut Lock Flg 3/8-16 unc
53	532 18 89-67	Washer Hardened .793 x 1.637 x .060
54	874 76 06-36	Bolt Hex 3/8-16 unc x 2-1/4
55	532 41 47-36	Bolt Hex 3/8-16 unc x 2-1/4
58	532 19 47-47	Bolt Shoulder Sector Pivot CFM
59	532 19 47-48	Washer Thrust Sector Steering
60	873 97 10-00	Nut Flange Lock 5/8-11
61	588 79 44-01	Draglink, LH
62	588 79 45-01	Draglink, RH
63	817 00 05-12	Screw 5/16-18 x 3/4
64	532 19 98-49	Retainer Clip Spring Steering
65	532 19 47-34	Brace Axle Front
66	871 02 07-48	Bolt Hex Fghd 7/16-14 x 3 Serr
67	532 19 47-37	Bushing PM Front Axle
68	873 90 07-00	Nut Lock Flange 7/16-14 Gr. 5
69	532 19 91-62	Washer 1.5 x .505 x .118
70	585 33 88-01	Bracket Deck Susp. Front
75	580 68 37-01	Pinion
76	580 68 36-01	Screw Head Sock
78	532 05 70-79	Washer Thrust
122	532 44 49-62	Cap Gear Sector

NOTE: All component dimensions given in U.S. inches
1 inch = 25.4 mm

**TRACTOR - MODEL NO. TS 354XD (96043024500), PRODUCT NO. 960 43 02-45
MOWER DECK**

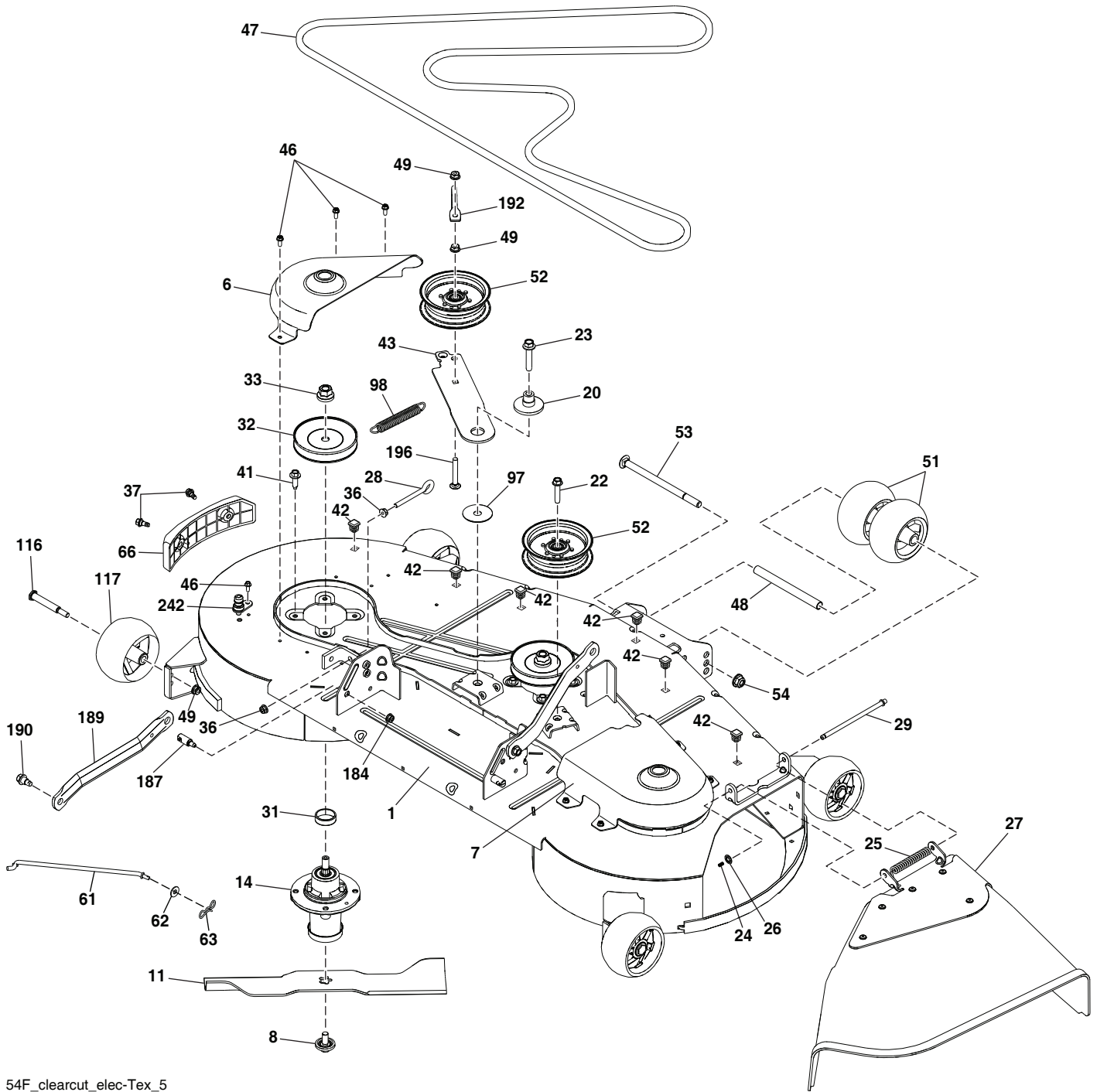

54F_clearcut_elec-Tex_5

**TRACTOR - MODEL NO. TS 354XD (96043024500), PRODUCT NO. 960 43 02-45
MOWER DECK**

KEY NO.	PART NO.	DESCRIPTION
1	588 54 90-02	Deck Weldment Mower
6	590 30 43-03	Cover Mandrel LH
7	590 30 42-03	Cover Mandrel RH
8	532 19 30-03	Bolt/Washer Am 7/16-20
11	582 76 05-08	Blade 54cc
14	539 13 17-67	Housing, Mandrel
20	532 19 72-36	Spacer Idler Pulley
22	817 49 06-28	Screw THDROL 3/8-16 x 1-3/4
23	588 43 83-01	Screw 7/16-14 x 2.125 Washer
24	532 10 53-04	Cap Sleeve
25	587 35 47-01	Spring, Torsion
26	532 11 04-52	Nut, Push
27	590 63 22-01	Deflector Shield
28	539 11 55-74	Bolt Eye 5/16 x 3-1/2
29	532 13 14-91	Rod, Hinge
31	532 18 76-90	Washer Spacer Mandrel
32	532 15 35-35	Pulley, Mandrel
33	532 40 02-34	Nut, Flg. Top Lock
36	539 99 05-85	Nut 5/16-18 Hex
37	532 17 01-65	Bolt Shoulder 5/16-18
41	584 95 39-01	Bolt Hex Wshr .313 - 18 x 1.19
42	596 95 22-01	Plug, Hole, Square
43	582 21 96-02	Arm, Idler
46	532 13 77-29	Screw, Thdroll. 1/4-20 x 5/8
47	582 23 63-01	V-Belt, Mower
48	574 19 65-01	Tube Roller
49	873 90 06-00	Nut, Lock Flg. 3/8-16 unc
51	574 16 96-01	Roller Gauge

KEY NO.	PART NO.	DESCRIPTION
52	532 19 73-79	Pulley Idler 4.50
53	872 14 08-64	RHSNB 1/2-13 x 8 Gr. 5 ZD
54	521 99 11-01	Nut 1/2-13 Hex Flg Nyloc ZD
61	532 40 03-37	Rod Anti-Sway
62	819 13 13-12	Washer 13/32 x 13/16 x 12 Ga.
63	532 19 42-08	Pin Cotter 5/16 Bow Tie Lock
66	590 73 25-01	Bumper Asm 54cc
97	532 17 85-15	Washer Hardened
98	587 35 84-01	Spring Drive
116	532 19 34-06	Bolt, Shoulder
117	532 17 48-73	Gauge Wheel
184	873 90 05-00	Nut Lock Hex Flange 5/16-18
187	532 19 51-61	Stud Fastener w/"D" Anti-Rotation
189	532 19 51-85	Arm Susp. Mower Rear
190	532 19 65-39	Bolt Shoulder
192	532 19 84-68	Keeper Belt Idler
196	872 14 06-20	Bolt Rdhd 3/8-16 unc x 2-1/2 Gr. 5
242	532 41 55-98	Port Washout
--	532 41 64-05	Coupling Quick Connect
--	592 61 89-01	Replacement Mower, Complete

NOTE: All component dimensions given in U.S. inches
1 inch = 25.4 mm

**TRACTOR - MODEL NO. TS 354XD (96043024500), PRODUCT NO. 960 43 02-45
MOWER LIFT**

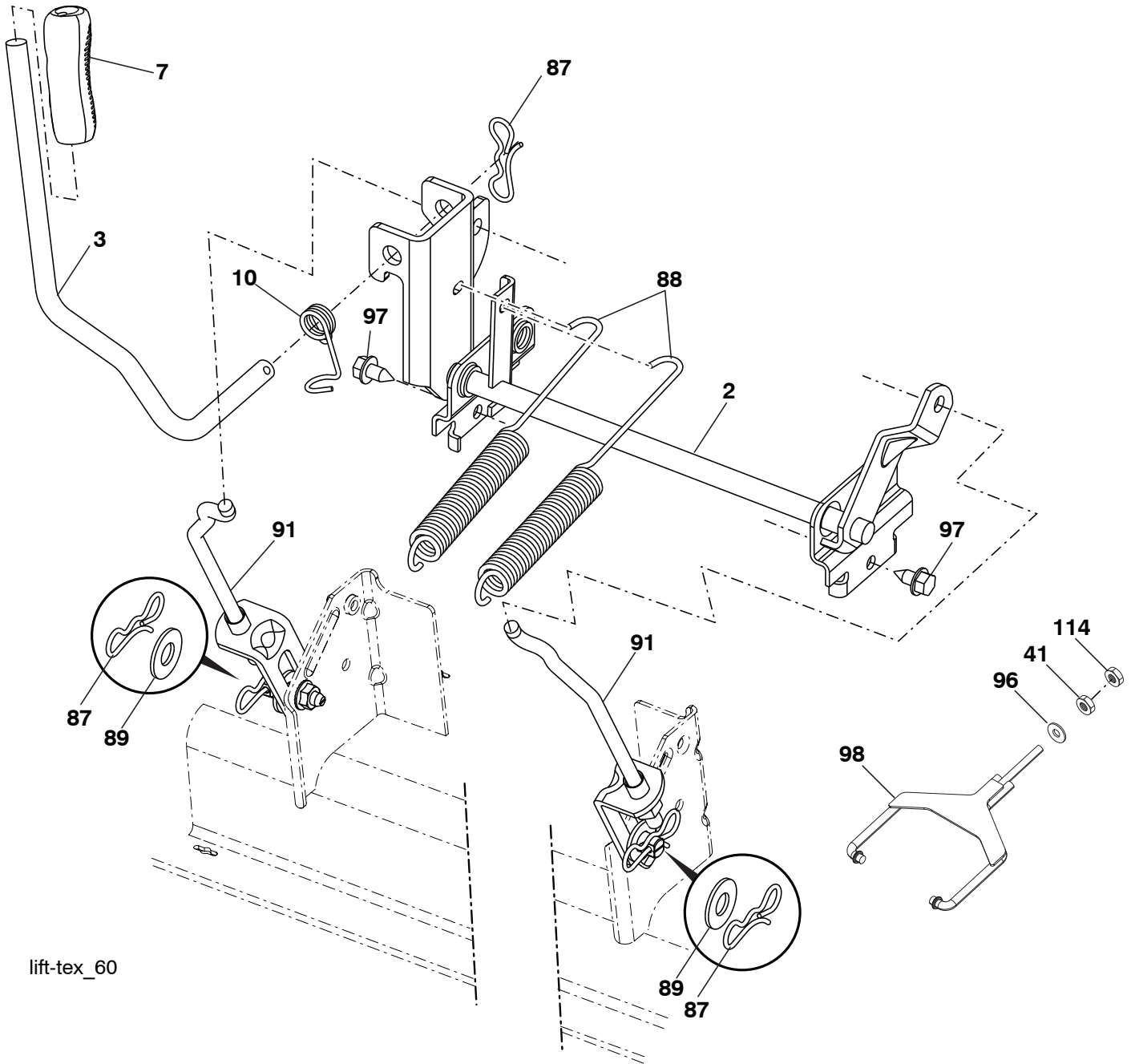

lift-tex_60

KEY NO.	PART NO.	DESCRIPTION
2	532 42 20-27	Shaft Asm., Lift
3	532 19 52-30	Lever Asm., Lift RH
7	580 96 23-01	Grip, Lever
10	532 19 63-14	Spring Torsion
41	532 17 59-94	Nut Lift Link
87	532 19 42-09	Pin Cotter 7/16 Bow Tie Lock
88	532 19 53-04	Spring Lift Assist
89	819 19 19-12	Washer Clear Zinc
91	532 40 34-07	Link Lift Susp Mower Rear

KEY NO.	PART NO.	DESCRIPTION
96	532 19 52-63	Bushing Spherical
97	817 00 06-12	Screw 3/8-16 x .75
98	589 31 87-03	Link Lift Susp. Front Mower
114	873 36 07-00	Nut Jam 7/16-20

NOTE: All component dimensions given in U.S. inches
1 inch = 25.4 mm

**TRACTOR - MODEL NO. TS 354XD (96043024500), PRODUCT NO. 960 43 02-45
SEAT ASSEMBLY**

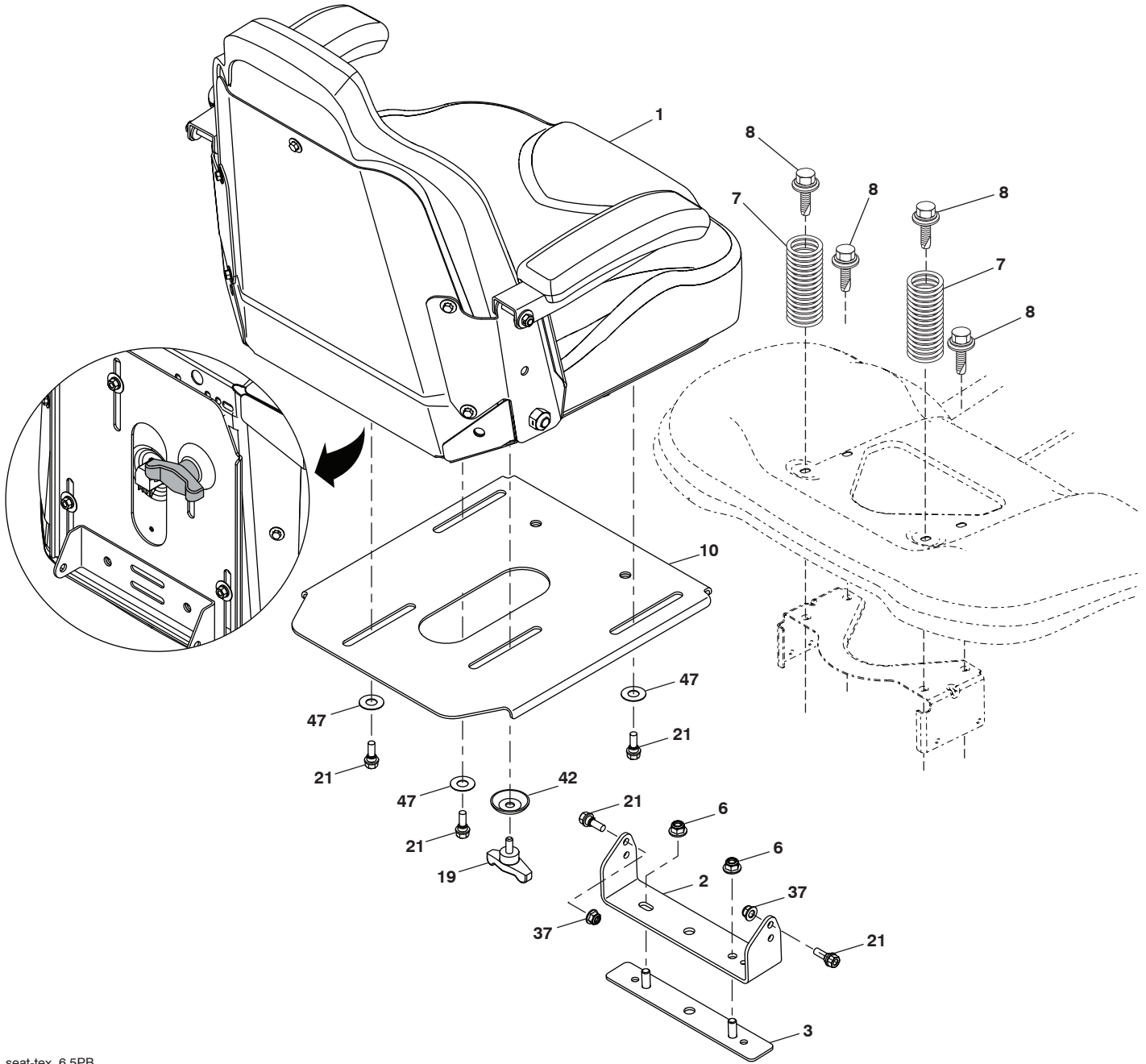

seat-tex_6.5PB

KEY NO.	PART NO.	DESCRIPTION
1	590 33 73-02	Seat
2	590 33 66-02	Bracket Pivot Fender
3	590 77 76-02	Bracket Pivot Seat
6	521 99 65-01	Nut, Lock 3/8-16 unc
7	590 81 23-01	Spring, Seat Cprsn
8	532 17 18-77	Bolt 5/16-18 x 3/4 w/Sems
10	590 48 17-02	Pan, Seat
19	590 69 15-01	Knob Seat
21	532 16 96-12	Bolt, Shoulder 5/16-18 x 5/8

KEY NO.	PART NO.	DESCRIPTION
37	539 11 28-99	Nut, Lock 5/16-18 Hex
42	532 19 93-71	Washer Cup
47	590 35 11-01	Washer Nylon .05 x 1.12 x .033

NOTE: All component dimensions given in U.S. inches
1 inch = 25.4 mm

**TRACTOR - MODEL NO. TS 354XD (96043024500), PRODUCT NO. 960 43 02-45
DECALS**

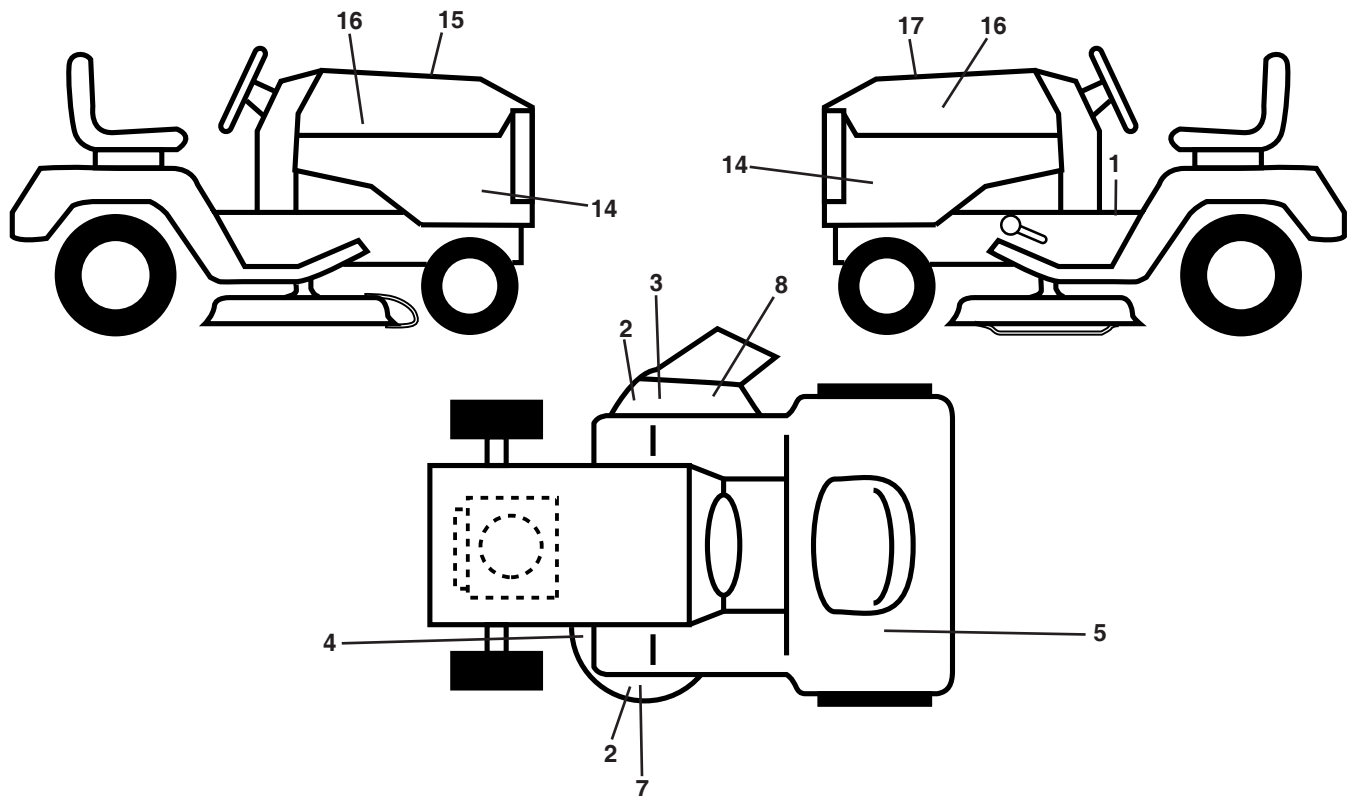

KEY PART NO. NO. DESCRIPTION

1	581 57 89-01	Decal, Warning
2	589 35 79-01	Decal, No Step
3	591 16 47-01	Decal, Mower Beltrouting
4	592 89 83-01	Decal, Deck Warning
5	587 01 51-01	Decal, Fuel Reserve
7	590 88 51-01	Decal, Deck 54CC
8	586 97 88-01	Decal, Deflect. Warning
14	591 44 87-01	Decal, Panel Side
15	532 42 38-29	Decal, Cust. Resp.
16	581 62 73-01	Decal, Hood Logo
17	590 93 74-01	Decal, Replacement
--	581 57 90-01	Decal, Fender Warning (English/French)

KEY PART NO. NO. DESCRIPTION

--	581 72 48-01	Decal, Bypass
--	586 74 22-01	Decal, Fuel Reserve (English/French)
--	532 43 98-82	Pad, Footrest, LH
--	532 43 98-81	Pad, Footrest, RH
--	115 99 43-49	Manual, Operator's (English/Spanish)
--	115 99 46-32	Manual, Operator's (French)
--	115 99 44-49	Manual, Part's (English/Spanish)
--	115 99 45-32	Manual, Part's (French)
--	587 71 00-26	Manual, QSG Husq (English/Spanish)
--	587 71 01-26	Manual, QSG Husq (English/French)

WHEELS AND TIRES

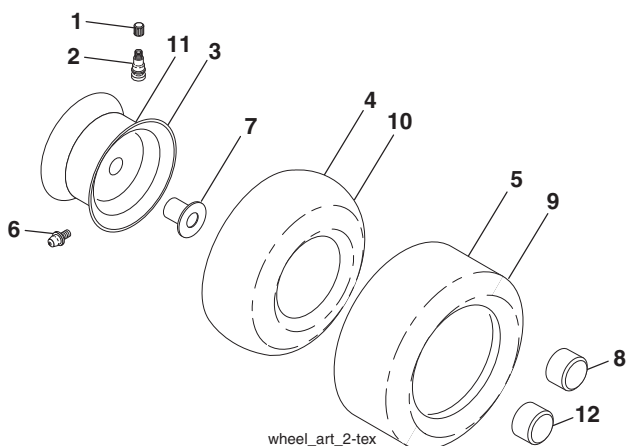

KEY PART NO. NO. DESCRIPTION

1	532 05 91-92	Cap, Valve, Tire
2	532 06 51-39	Stem, Valve
3	532 18 18-39	Rim Assembly, Front
4	532 00 81-34	Tube, Front (Service Item Only)
5	593 14 51-01	Tire, Front 16 x 6.5-8
6	532 12 49-57	Fitting, Grease (Front Wheel Only)
7	532 12 49-59	Bearing, Flange (Front Wheel Only)
8	532 17 50-39	Cap, Axle, Front
9	593 14 52-01	Tire, Rear 23 x 10.5-12
10	532 00 71-54	Tube, Rear (Service Item Only)
11	593 14 48-01	Rim Assembly, Rear
12	501 50 31-01	Cap, Hub, GT, PM, Black, Rear
--	532 14 43-34	Sealant, Tire (10 oz. Tube)

NOTE: All component dimensions given in U.S. inches
1 inch = 25.4 mm

TRACTOR MODELO NO. TS 354XD (96043024500), PRODUCTO NO. 960 43 02-45 DIAGRAMA

SCH27-s

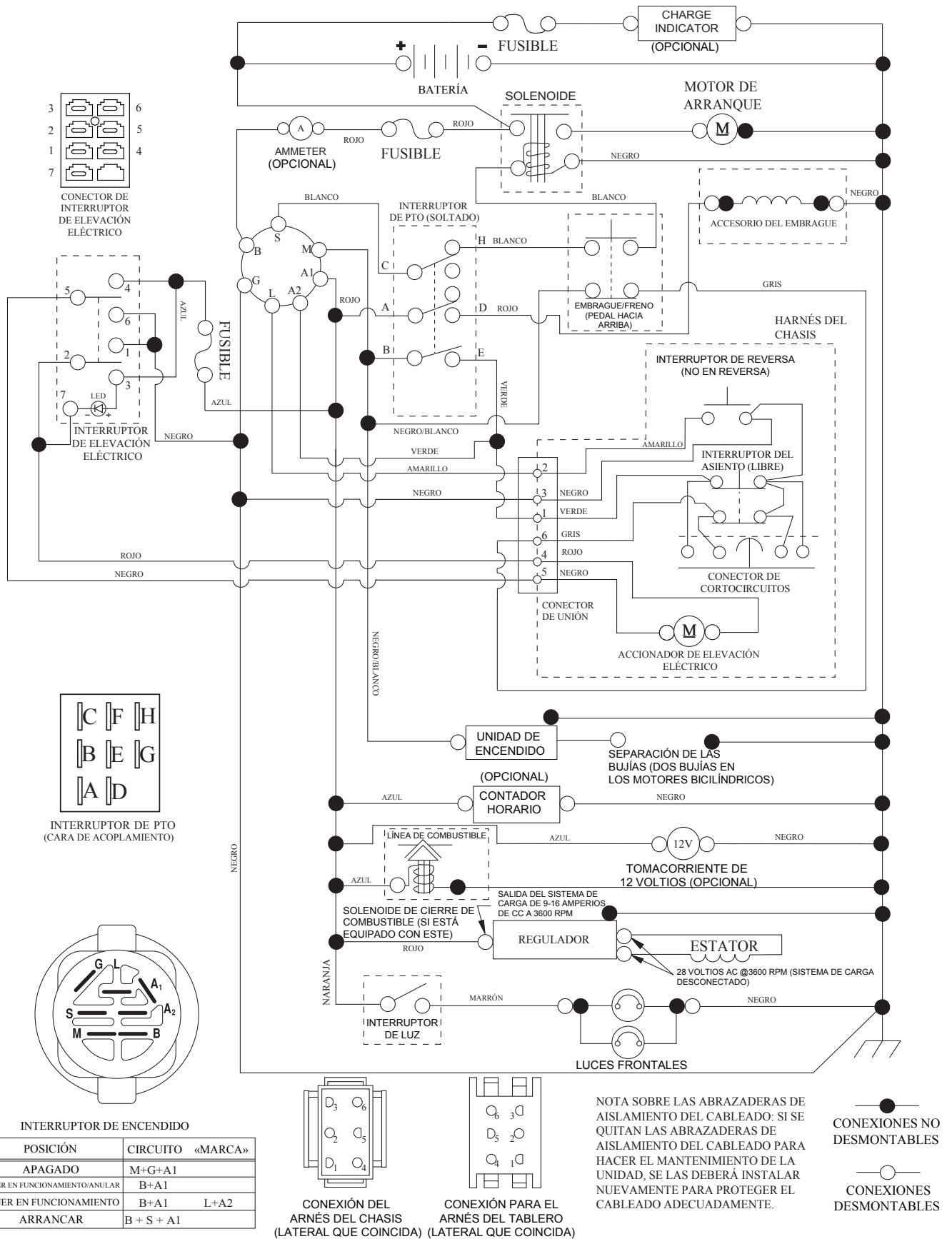

TRACTOR MODELO NO. TS 354XD (96043024500), PRODUCTO NO. 960 43 02-45

DIAGRAMA ELÉCTRICO

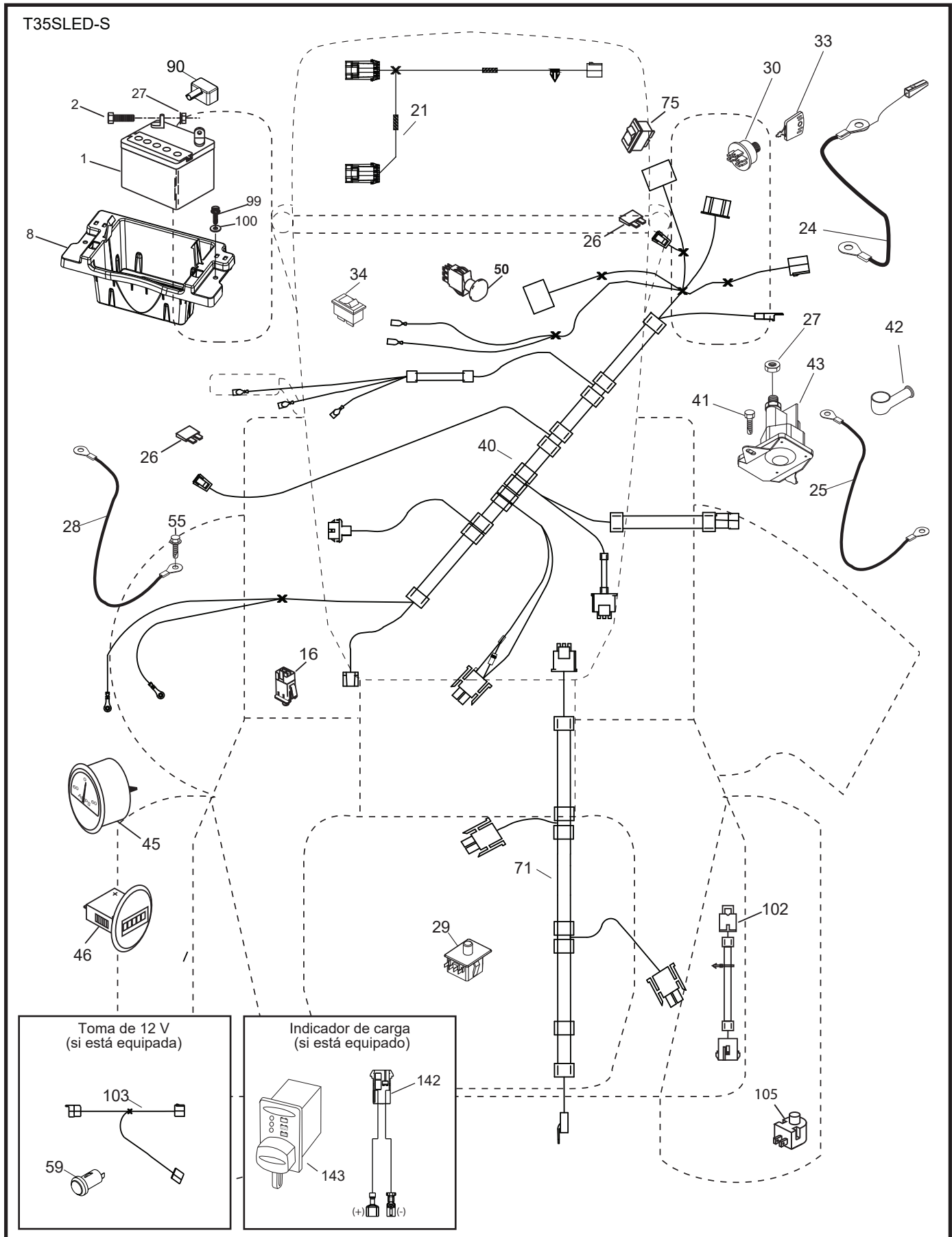

**TRACTOR MODELO NO. TS 354XD (96043024500), PRODUCTO NO. 960 43 02-45
DIAGRAMA ELÉCTRICO**

CÓDIGO No.	PIEZA No.	DESCRIPCIÓN
1	532 16 34-65	Batería
2	874 76 04-12	Perno de cabeza hexagonal de 1/4-20 x 3/4
8	587 20 51-01	Caja de la batería
16	532 17 61-38	Interruptor corta corriente a presión
21	585 43 64-01	Cableado del enchufe para la luz
24	585 55 56-01	Cable
25	585 55 55-01	Cable
26	532 17 51-58	Fusible
27	873 51 04-00	Tuerca hexagonal Keps de 1/4-20 unc
28	532 41 65-88	Cable a tierra
29	532 19 27-49	Interruptor del asiento
30	532 19 33-50	Interruptor de encendido
33	532 41 19-35	Llave/cadena
34	532 11 07-12	Interruptor de luz/de restauración
40	501 13 36-01	Cableado de encendido
41	817 72 04-08	Tornillo
42	532 13 15-63	Cubierta de la terminal
43	582 04 28-01	Solenoides
45	587 55 39-03	Amperímetro
46	587 55 40-03	Cuentahoras
50	582 10 76-01	Interruptor PTO
55	817 06 05-12	Tornillo de 5/16-18 x 3/4
71	580 51 30-01	Cableado de encendido, chasis\
75	580 36 64-01	Interruptor
90	532 43 53-95	Tapa de los bornes de la batería
99	817 67 04-12	Tornillo 1/4-20 x 3/4
100	819 09 14-16	Arandela
102	532 40 44-54	Arnés de cableado
105	532 40 75-68	Interruptor de retroceso
142	583 85 78-01	Coleta del puerto de carga
143	532 44 80-59	Puerto de carg

NOTA: Las dimensiones de todos los componentes están expresadas en pulgadas americanas. 1 pulgada = 25,4 mm

TRACTOR MODELO NO. TS 354XD (96043024500), PRODUCTO NO. 960 43 02-45

CHASIS

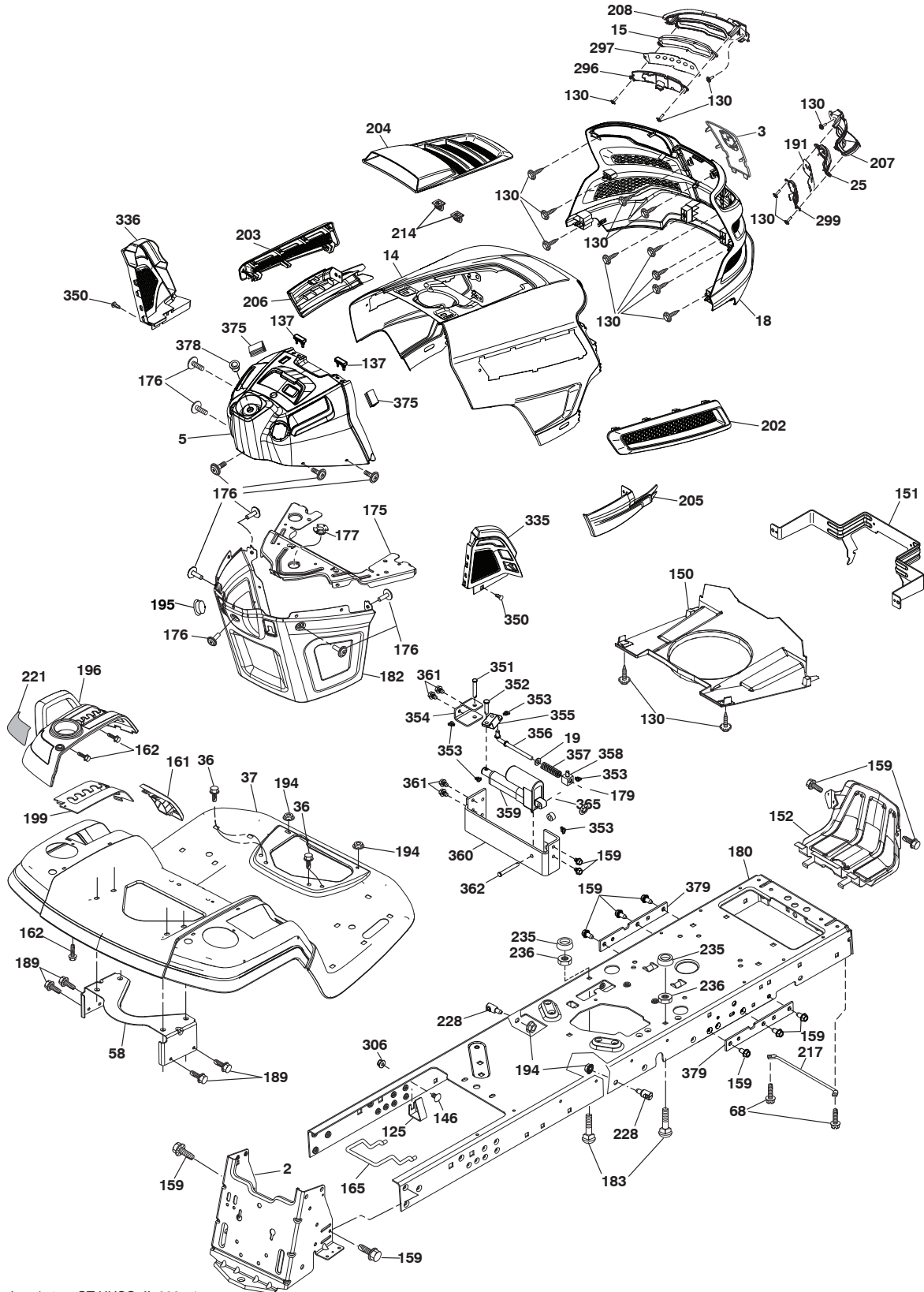

chassis-tex_GT HUSQ_II_236_r1

**TRACTOR MODELO NO. TS 354XD (96043024500), PRODUCTO NO. 960 43 02-45
CHASIS**

CÓDIGO No.	PIEZA No.	DESCRIPCIÓN	CÓDIGO No.	PIEZA No.	DESCRIPCIÓN
2	580 43 44-01	Barra de tracción	205	532 43 97-30	Camisa de Capota (LD)
3	532 44 44-81	Aplica Submontaje	206	532 43 97-29	Camisa de Capota (LI)
5	590 74 00-22	Tablero	207	585 42 00-02	Bisel derecho
14	532 44 11-77	Capota	208	585 42 01-02	Bisel izquierdo
15	585 42 03-01	Lente izquierdo de la parrilla	214	532 19 91-45	Cierre
18	587 52 34-01	Parrilla	217	532 40 91-67	Varilla giratoria
19	819 13 13-12	Tornillo 13/32 x 13/16 x 12	218	532 19 63-95	Tope
25	585 42 02-01	Lente derecho de la parrilla	221	532 19 89-09	Reflector (LI)
36	817 06 05-12	Tornillo de 5/16-18 x 3/4	228	532 19 51-61	Sujetador del travesaño
37	532 44 12-08	Guardabarros	235	532 40 61-29	Separador del guardabarros
58	532 19 43-14	Soporte de Guardabarros	236	873 93 05-00	Tuerca de presión 5/16-18 unc
68	539 99 08-58	Tornillo de 5/16-18 x 1/2	296	585 42 05-01	Luz LED (LI)
125	581 68 48-01	Soporte	297	586 18 29-01	Parte movable reflexivo (LI)
130	532 41 63-58	Tornillo No. 10 x 0,75	299	585 42 04-01	Luz LED(LD)
137	532 40 75-90	Cubierta Tablero	306	873 90 06-00	Tuerca
146	581 85 79-01	Perno	335	532 44 82-04	Cubierta (LD)
150	532 43 97-74	Cubierta	336	532 44 53-09	Cubierta (LI)
151	532 43 66-70	Soporte de Capota	350	532 44 51-43	Cierre del árbol de navidad
152	532 43 98-70	Protector contra oscurecimiento	351	532 42 17-34	Clavija de horquilla .375 x 2.125
159	817 00 06-12	Tornillo 3/8-16 x 3/4	352	532 44 86-34	Clavija .375 x 2.125
161	532 43 99-29	Abastecza de combustible ventana	353	532 17 80-62	Pinzas de retención .0375
162	532 14 24-32	Tornillo	354	532 44 86-19	Soporte
165	532 19 43-30	Soporte de Tanque de Gasolina	355	532 44 86-36	Mecanismo
175	590 60 77-02	Travesaño	356	532 44 86-93	Acoplamiento
176	532 40 07-76	Tornillo de 10-24 x 5/8	357	532 44 86-84	Resorte
177	532 19 52-28	Buje de dirección	358	580 36 66-01	Guía
179	532 16 89-37	Tuerca de presión	359	584 39 34-01	Accionador
180	593 34 63-01	Chasis	360	532 44 86-18	Soporte del accionador
182	532 40 68-59	Tablero inferior	361	817 49 06-10	Tornillo 3/8-16 x 5/8
183	874 52 05-20	Perno 5/16-18 x 1-1/4	362	532 44 86-33	Clavija .375 x 2.42
189	817 00 05-12	Tornillo	365	532 44 73-68	Separador .375 x .4375L
191	586 18 28-01	Parte movable reflexivo (LD)	375	586 90 82-01	Cubierta Capota
194	873 90 05-00	Tuerca de presión de 5/16-18	378	590 84 98-01	Cojinete
195	532 40 41-37	Agujero del tapón inferior de tablero	379	593 20 69-02	Refuerzo de la placa del chasis
196	532 43 96-74	Ensamble de la consola de la plata- forma de elevación	--	532 43 18-82	Protector del cepillo
199	532 19 82-59	Chapa			
202	532 43 97-28	Salida de Ventilación (LD)			
203	532 43 97-27	Salida de Ventilación (LI)			
204	532 44 44-84	Salida de Ventilación superior			

NOTA: Las dimensiones de todos los componentes están expresadas en pulgadas americanas. 1 pulgada = 25,4 mm

TRACTOR MODELO NO. TS 354XD (96043024500), PRODUCTO NO. 960 43 02-45
TRANSMISIÓN

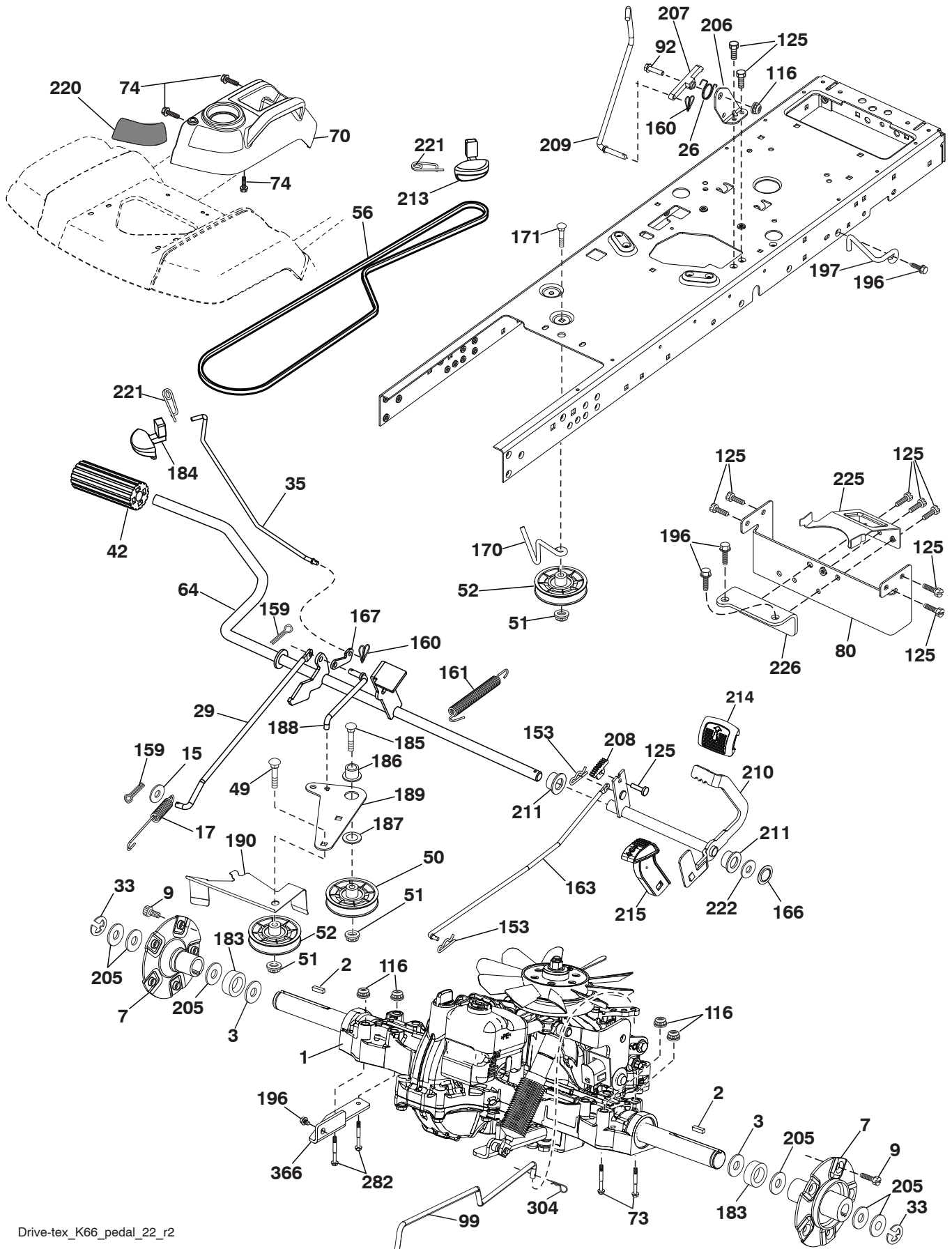

Drive-tex_K66_pedal_22_r2

TRACTOR MODELO NO. TS 354XD (96043024500), PRODUCTO NO. 960 43 02-45

TRANSMISIÓN

CÓDIGO No.	PIEZA No.	DESCRIPCIÓN	CÓDIGO No.	PIEZA No.	DESCRIPCIÓN
1	---	Transeje, Tufftorq K66ELD (580402201) (Haga el pedido de las piezas al fabricante del transeje.)	171	872 11 06-16	Perno 3/8-16 x 2.00
			183	587 58 74-01	Espaciador
			184	587 65 37-01	Manija del freno de mano
2	539 91 27-57	Cuña .25 x 1.25	185	872 11 06-22	Perno 3/8-16 unc x 2-3/4 grado 5
3	532 00 75-63	Arandela	186	532 19 43-21	Espaciador de retención
7	586 93 54-02	Ruede eje la asamblea	187	819 13 32-10	Arandela
9	532 14 00-80	Perno	188	582 21 70-01	Mecanismo de desplazamiento de la varilla de mando del embrague
15	819 13 13-16	Arandela 13/32 x 13/16 x calibre 16			
17	532 40 10-72	Resorte de freno	189	532 19 43-17	Palanca acodada del mecanismo de desplazamiento
26	532 19 96-79	Crucero con retorno de muelle			
29	532 40 72-45	Varilla del freno	190	532 19 43-18	Sujetador de la palanca acodada del mecanismo de desplazamiento
33	812 00 00-53	Aro "E"			
35	590 60 59-01	Varilla del freno de mano	196	817 00 06-16	Tornillo 3/8-16 x 1
42	532 12 48-72	Cubierta del pedal	197	585 65 86-01	Soporte
49	872 11 06-14	Perno 3/8-16 x 1-3/4	205	532 12 38-00	Arandela 1-1/32 x 1-5/8 x calibre 16
50	532 19 43-27	Polea loca plana	206	532 44 85-96	Soporte
51	873 90 06-00	Tuerca 3/8-16	207	587 03 14-01	Bloqueo del control del crucero
52	532 19 43-26	Polea loca con ranura en V con un desplazamiento	208	532 19 78-69	Engranaje del sector de control del crucero
56	592 85 53-01	Correa trapezoidal de la transmisión	209	590 52 78-01	Varilla de control del crucero
64	532 19 78-65	Ensamble del eje control del pedal de freno	210	532 19 78-60	Ensamble del balancín del control del pedal
70	532 43 96-61	Ensamble del console	211	532 12 01-83	Rodamiento de nylon
73	874 49 05-44	Perno 5/16-18 x 3 Gr. 5	213	532 40 31-19	Perilla de control del crucero
74	532 14 24-32	Tornillo 1/4 x 1/2	214	532 42 12-63	Forro del pedal para avanzar
80	589 33 34-02	Correa de torsión	215	586 60 65-02	Forro del pedal para retroceder
92	874 76 05-20	Perno 5/16-18 x 1/2	220	532 19 89-08	Reflector (LD)
99	582 40 47-01	Resorte	221	532 40 31-87	Abrazadera de retención del resorte de la manija
116	873 90 05-00	Tuerca 5/16-18			
125	817 00 05-12	Tornillo 5/16-18 x 3/4	222	879 21 20-10	Arandela 21/32 x 1-1/4 x calibre 10
153	532 12 47-88	Retén del resorte	225	532 40 73-11	Sujetador de la correa
159	876 02 04-12	Pasador de chaveta de 1/8 x 3/4	226	532 40 71-09	Soporte de montaje
160	532 16 94-84	Abrazadera de retención	282	874 49 05-48	Perno 5/16-18 x 3.0 Gr 5
161	532 10 57-09	Resorte de retorno del embrague	304	532 42 33-03	Pasador de chaveta
163	532 40 72-46	Varilla de control del pedal	366	580 62 62-01	Soporte
166	532 42 91-64	Tuerca .625			
167	532 40 52-57	Pestillo del freno de mano			
170	532 19 43-22	Sujetador de la correa			

NOTA: Las dimensiones de todos los componentes están expresadas en pulgadas americanas. 1 pulgada = 25,4 mm

TRACTOR MODELO NO. TS 354XD (96043024500), PRODUCTO NO. 960 43 02-45
MOTOR

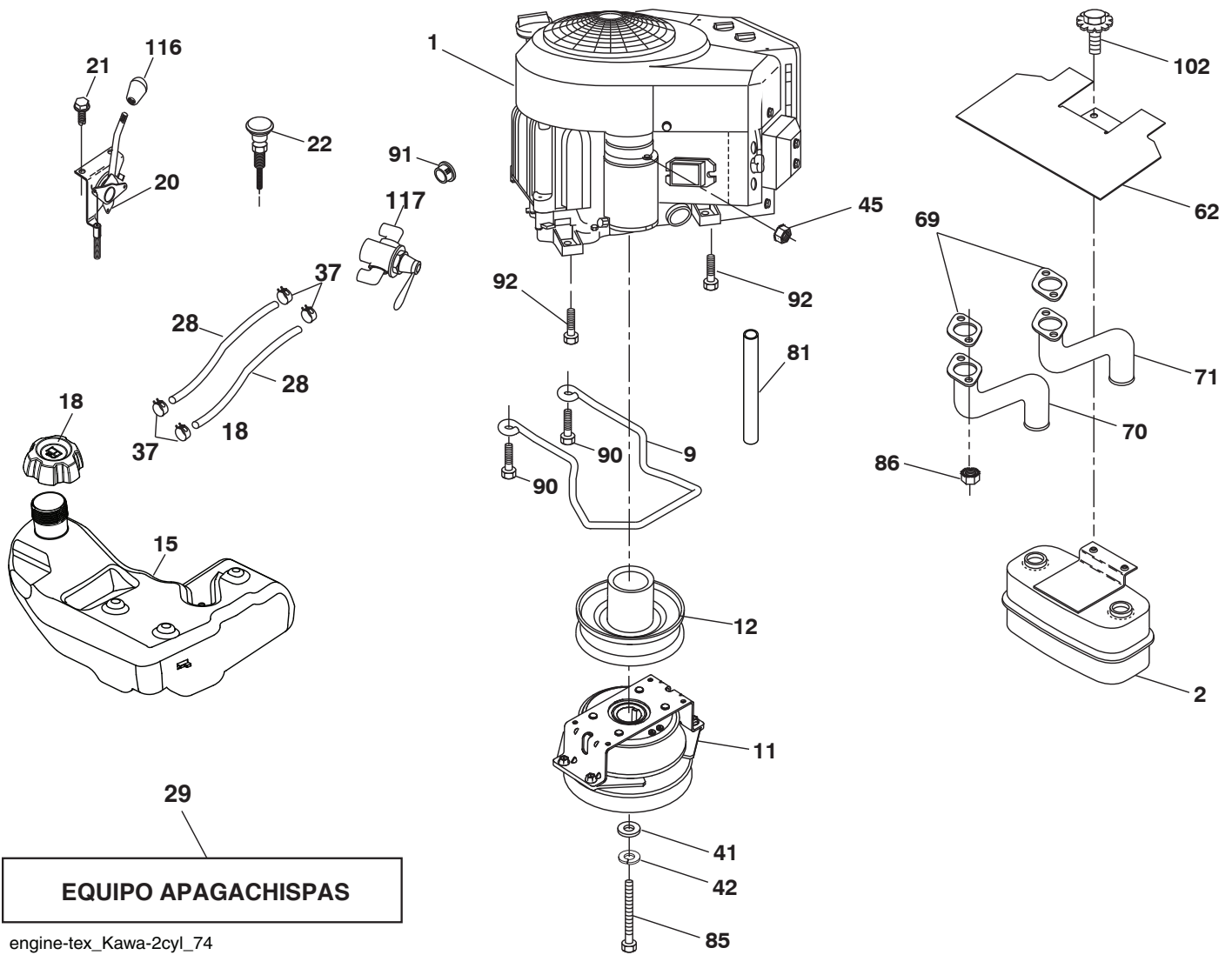

**TRACTOR MODELO NO. TS 354XD (96043024500), PRODUCTO NO. 960 43 02-45
MOTOR**

CÓDIGO No.	PIEZA No.	DESCRIPCIÓN
1	- - - - -	Motor KAWA modelo No. FR730V-ES04 (445363)(Haga el pedido de las piezas al fabricante del motor.)
2	589 81 87-01	Silenciador
9	501 83 26-01	Ensamble del sujetador de la correa del motor
11	587 24 14-01	Embrague de eléctrico
12	532 19 43-43	Polea del motor
15	532 43 80-22	Tanque de Gasolina de 4,0 R
18	585 12 48-01	Tapa
20	532 42 43-41	Control del regulador
21	532 41 63-58	Tornillo No. 10 x 0,75 con rosca reforzada
22	532 19 15-96	Control de la estrangulación del motor
28	587 04 48-61	Línea de combustible
29	532 13 71-80	Equipo apagachispas
37	532 12 34-87	Abrazadera de la manguera
41	532 12 61-97	Arandela 1-1/2 x 15/32 x .250
42	539 99 02-47	Arandela SLW STD 7/16
45	873 51 04-00	Tuerca
62	532 43 40-17	Silenciador con pantalla térmica
69	532 17 81-51	Junta
70	583 95 56-01	Tubo de escape izquierdo
71	583 95 57-01	Tubo de escape derecho
81	532 14 84-56	Tubo de drenaje
85	501 60 69-01	Perno de 7/16-20 x 3.0 x grado 5
86	532 18 43-62	Tuerca
90	817 00 06-16	Tornillo de 3/8-16 x 1
91	532 18 74-95	Buje
92	817 12 06-16	Tornillo 3/8-16 x 1
116	539 13 26-24	Tacto suave de la perilla
117	532 42 08-28	Reserva de combustible de válvula

NOTA: Las dimensiones de todos los componentes están expresadas en pulgadas americanas. 1 pulgada = 25,4 mm
Para las piezas del servicio y de recambio del motor, llame el número gratis para su fabricante del motor enumerado abajo:
Kawasaki 1-949-460-5688

TRACTOR MODELO NO. TS 354XD (96043024500), PRODUCTO NO. 960 43 02-45
ENSAMBLE DE LA DIRECCIÓN

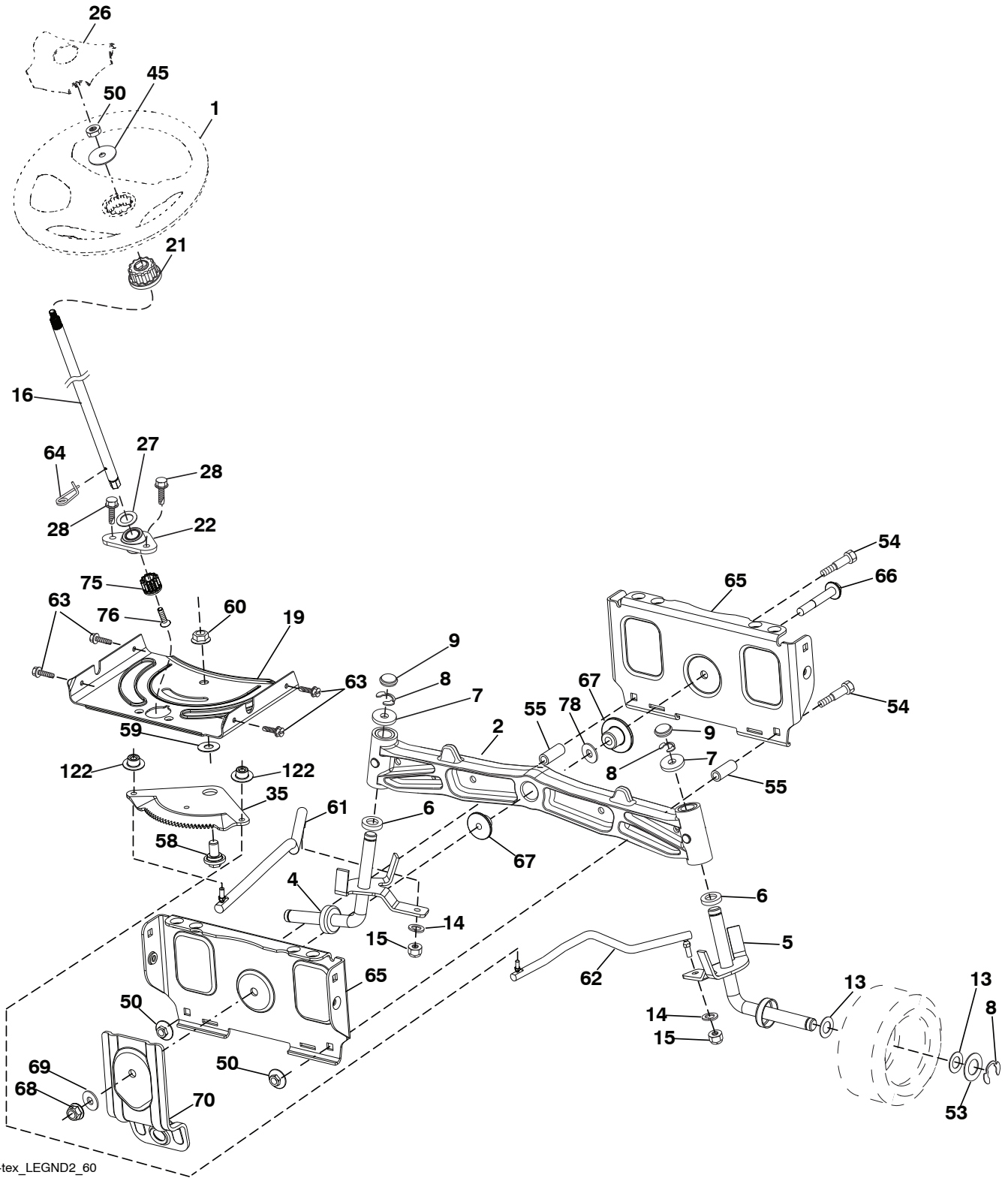

Steering-tex_LEGND2_60

**TRACTOR MODELO NO. TS 354XD (96043024500), PRODUCTO NO. 960 43 02-45
ENSAMBLE DE LA DIRECCIÓN**

CÓDIGO No.	PIEZA No.	DESCRIPCIÓN
1	532 43 97-40	Volante de dirección
2	532 19 59-68	Ensamble del eje delantero
4	532 40 30-89	Ensamble del husillo izquierdo
5	532 40 30-90	Ensamble del husillo derecho
6	532 12 49-31	Pista del rodamiento para reforzar el impulso
7	532 12 17-48	Arandela de 25/32 x 1-5/8 calibre 16
8	812 00 00-29	Abrazadera del aro No. T5304-75
9	532 12 12-32	Tapa del husillo
13	532 12 17-49	Arandela de 25/32 x 1-1/4 calibre 16
14	539 99 01-18	Arandela SLW STD 3/8
15	873 54 06-00	Tuerca de 3/8-24 uní
16	587 01 60-02	Eje de dirección
19	532 19 47-29	Placa de dirección
21	586 84 02-01	Adaptador del volante de dirección
22	585 02 99-01	Rodamiento
26	532 43 97-43	Inserto del volante de dirección
27	819 21 16-16	Arandela
28	817 00 06-12	Tornillo de 3/8-16 x 3/4
35	532 19 47-32	Engranaje del sector de la placa
45	587 01 64-01	Arandela 3/8 ID 2-3/8 OD calibre 12 PLTD
50	873 90 06-00	Tuerca 3/8-16 unc
53	532 18 89-67	Arandela reforzada de, 793 x 1,637 x 0,060
54	874 76 06-36	Tornillo 3/8-16 unc x 2-1/4
55	532 41 47-36	Tornillo 3/8-16 unc x 2-1/4
58	532 19 47-47	Perno de tope del sector del pivote CFM
59	532 19 47-48	Arandela de empuje del sector de dirección
60	873 97 10-00	Tuerca de 5/8-11
61	588 79 44-01	Barra de acoplamiento izquierda
62	588 79 45-01	Barra de acoplamiento derecha
63	817 00 05-12	Tornillo de 5/16-18 x 3/4
64	532 19 98-49	Abrazadera de retención del resorte de la dirección
65	532 19 47-34	Apoyo del árbol delantero
66	871 02 07-48	Perno de cabeza hexagonal con brida acanalada de 7/16-14 x 3
67	532 19 47-37	Buje PM del eje delantero
68	873 90 07-00	Tuerca de 7/16-14 grado 5
69	532 19 91-62	Arandela de 1,5 x 0,505 x 0,118
70	585 33 88-01	Soporte de la plataforma delantera
75	580 68 37-01	Piñón
76	580 68 36-01	Tornillo
78	532 05 70-79	Tuerca
122	532 44 49-62	Tapa

NOTA: Las dimensiones de todos los componentes están expresadas en pulgadas americanas. 1 pulgada = 25,4 mm

TRACTOR MODELO NO. TS 354XD (96043024500), PRODUCTO NO. 960 43 02-45
 PLATAFORMA DE LA CORTADORA DE CÉSPED

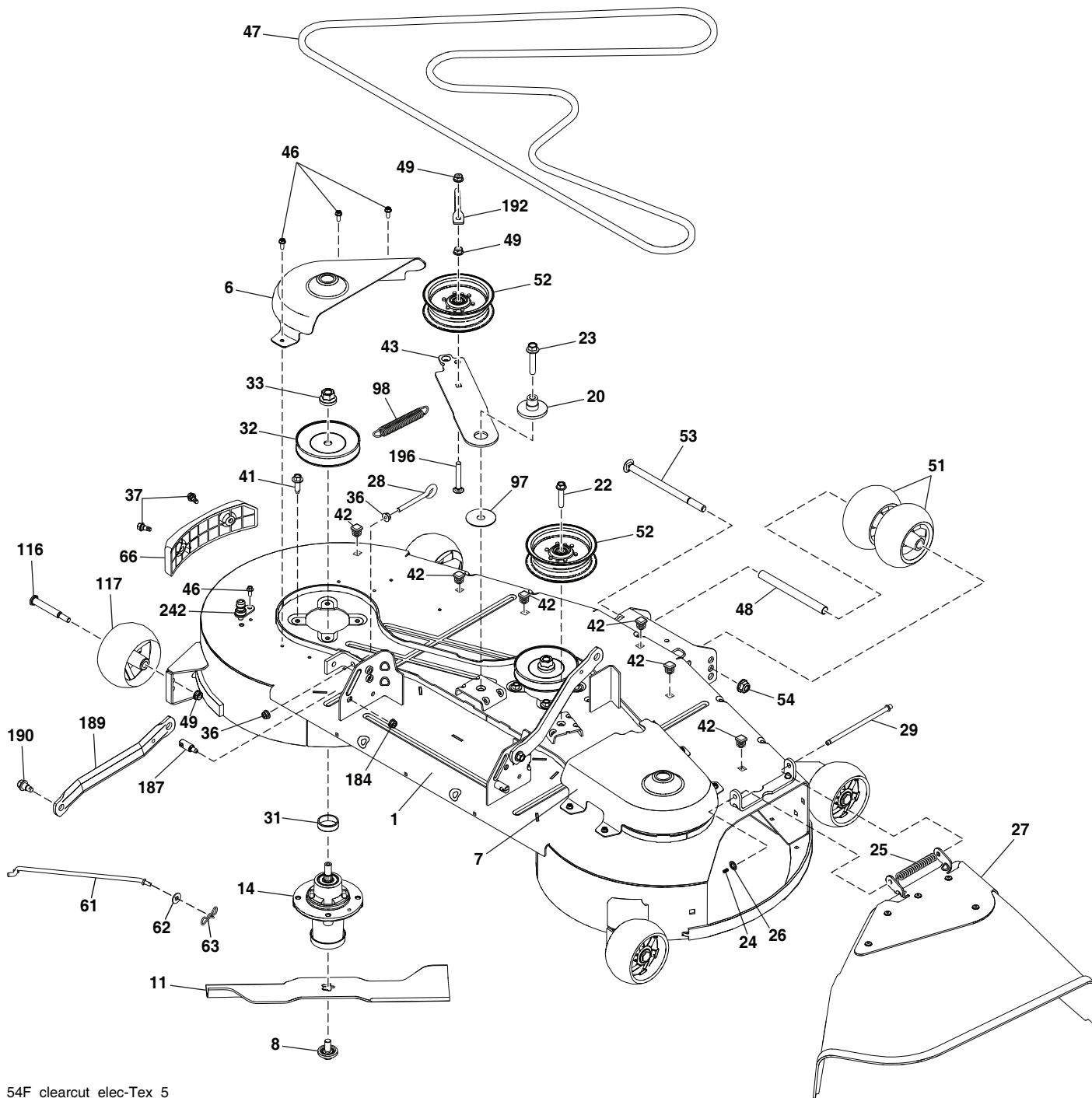

54F_clearcut_elec-Tex_5

**TRACTOR MODELO NO. TS 354XD (96043024500), PRODUCTO NO. 960 43 02-45
PLATAFORMA DE LA CORTADORA DE CÉSPED**

CÓDIGO No.	PIEZA No.	DESCRIPCIÓN	CÓDIGO No.	PIEZA No.	DESCRIPCIÓN
1	588 54 90-02	Carcasa de la cortadora de césped	53	872 14 08-64	RHSNB 1/2--13 x / Gr. 5 ZD
6	590 03 43-03	Brazo de la suspensión	54	521 99 11-01	Tuerca 1/2-13 Hex Flg
7	590 30 42-03	Tornillo #10 x 0.750 BOS	61	532 40 03-37	Barra contra la inclinación lateral
8	532 19 30-03	Perno/arandela del ensamble de 7/16-20	62	819 13 13-12	Arandela 13/32 x 13/16 x calibre 12
11	582 76 05-08	Cuchilla de la cortadora	63	532 19 42-08	Perno de tope
14	539 13 17-67	Carcasa del mandril	66	590 73 25-01	Parachoques 54cc
20	532 19 72-36	Polea loca	97	532 17 85-15	Arandela
22	817 49 06-28	Tornillo 3/8-16 x 1-3/4	98	587 35 84-01	Resorte
23	588 43 83-01	Tornillo 3/8-16 x 1-3/4 arandela	116	532 19 34-06	Perno
24	532 10 53-04	Tapa de la manga	117	532 17 48-73	Calibrador de la rueda
25	587 35 47-01	Resorte de torsión del deflector	184	873 90 05-00	Sujetador del travesaño
26	532 11 04-52	Tuerca de presión	187	532 19 51-61	Perno del perno prisionero
27	590 63 22-01	Protector del deflector	189	532 19 51-85	Tuerca de presión hexagonal con brida
28	539 11 55-74	Perno 5/16-18	190	532 19 65-39	Perno
29	532 13 14-91	Varilla de la bisagra	192	532 19 84-68	Sujetador
31	532 18 76-90	Arandela del separador	196	872 14 06-20	Perno 3/8-16 unc x 2-1/2 grado 5
32	532 15 35-35	Polea del mandril	242	532 41 55-98	Puerto de lavado de la cubierta
33	532 40 02-34	Tuerca de seguridad con brida	--	532 41 64-05	Acoplador
36	539 99 05-85	Tuerca de 5/16-18 Hex	--	592 61 89-01	Reemplazo de la cortadora de césped, completa
37	532 17 01-65	Perno 5/16-18			
41	584 95 39-01	Perno .313 - 18 x 1.19			
42	596 95 22-01	Enchufe cuadrado			
43	582 21 96-02	Resorte de torsión de retención			
46	532 13 77-29	Tornillo			
47	582 23 63-01	Soporte del cable de embrague			
48	574 19 65-01	Rodillo, m			
49	873 90 06-00	Tuerca Flg. 3/8-16 unc			
51	574 16 96-01	Calibradora,			
52	532 19 73-79	Polea			

NOTA: Las dimensiones de todos los componentes están expresadas en pulgadas americanas. 1 pulgada = 25,4 mm

TRACTOR MODELO NO. TS 354XD (96043024500), PRODUCTO NO. 960 43 02-45
ELEVACIÓN DE LA CORTADORA DE CÉSPED

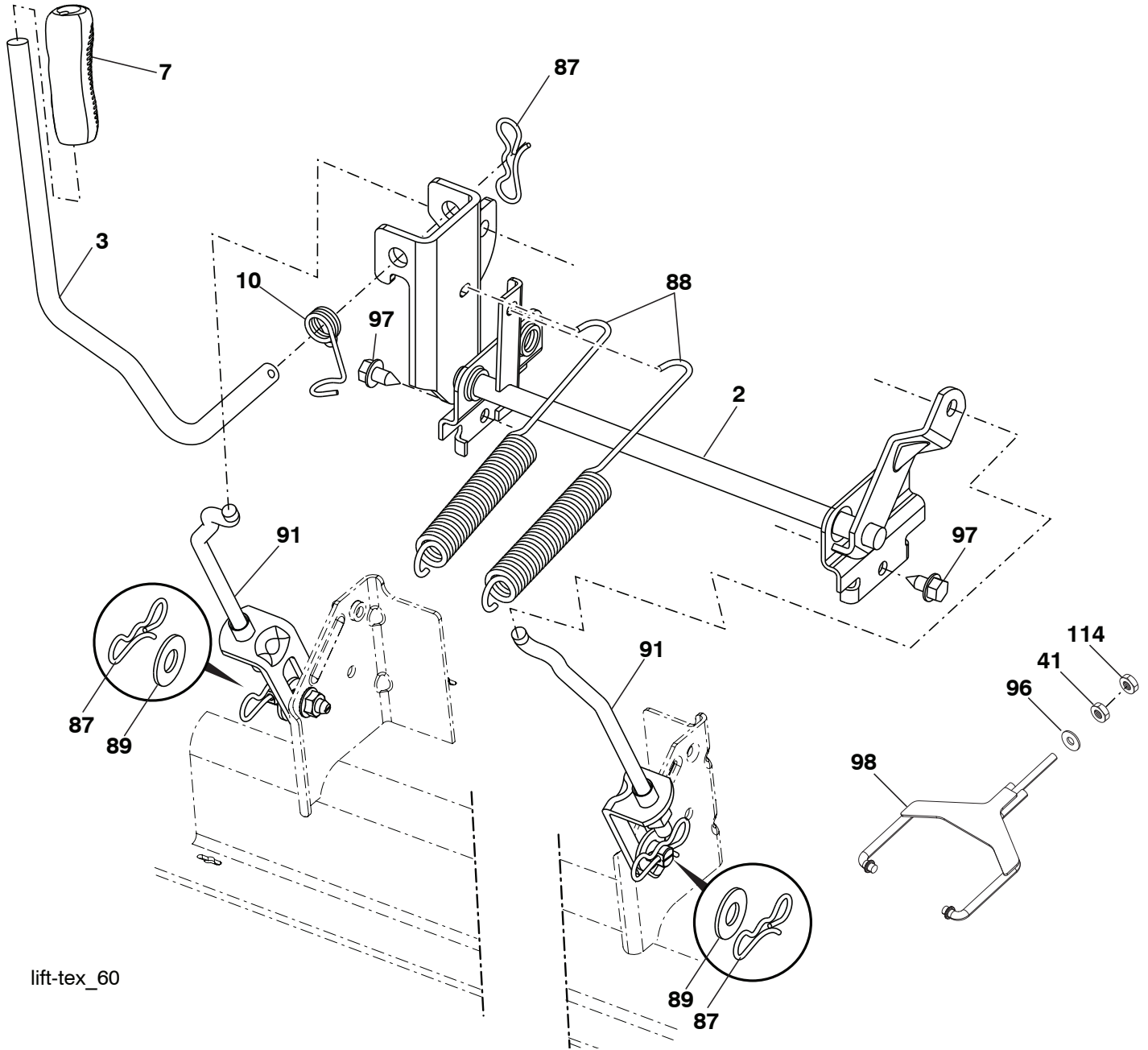

lift-tex_60

CÓDIGO No.	PIEZA No.	DESCRIPCIÓN
2	532 42 20-27	Ensamble del eje de la elevación
3	532 19 52-30	Ensamble de la palanca de elevación derecha
7	580 96 23-01	Mango de la palanca
10	532 19 63-14	Resorte de torsión
41	532 17 59-94	Tuerca
87	532 19 42-09	Pasador de chaveta de 7/16 con bloqueo en forma de mariposa
88	532 19 53-04	Resorte de ayuda de la elevación
89	819 19 19-12	Arandela de zinc transparente

CÓDIGO No.	PIEZA No.	DESCRIPCIÓN
91	532 40 34-07	Ensamble del acoplamiento Elevación trasera
96	532 19 52-63	Buje
97	817 00 06-12	Tornillo de 3/8-16 x 0,75
98	589 31 87-03	Acoplamiento frontal de la elevación de la cortadora de césped
114	873 36 07-00	Tuerca 7/16-20

NOTA: Las dimensiones de todos los componentes están expresadas en pulgadas americanas. 1 pulgada = 25,4 mm

**TRACTOR MODELO NO. TS 354XD (96043024500), PRODUCTO NO. 960 43 02-45
ENSAMBLE DEL ASIENTO**

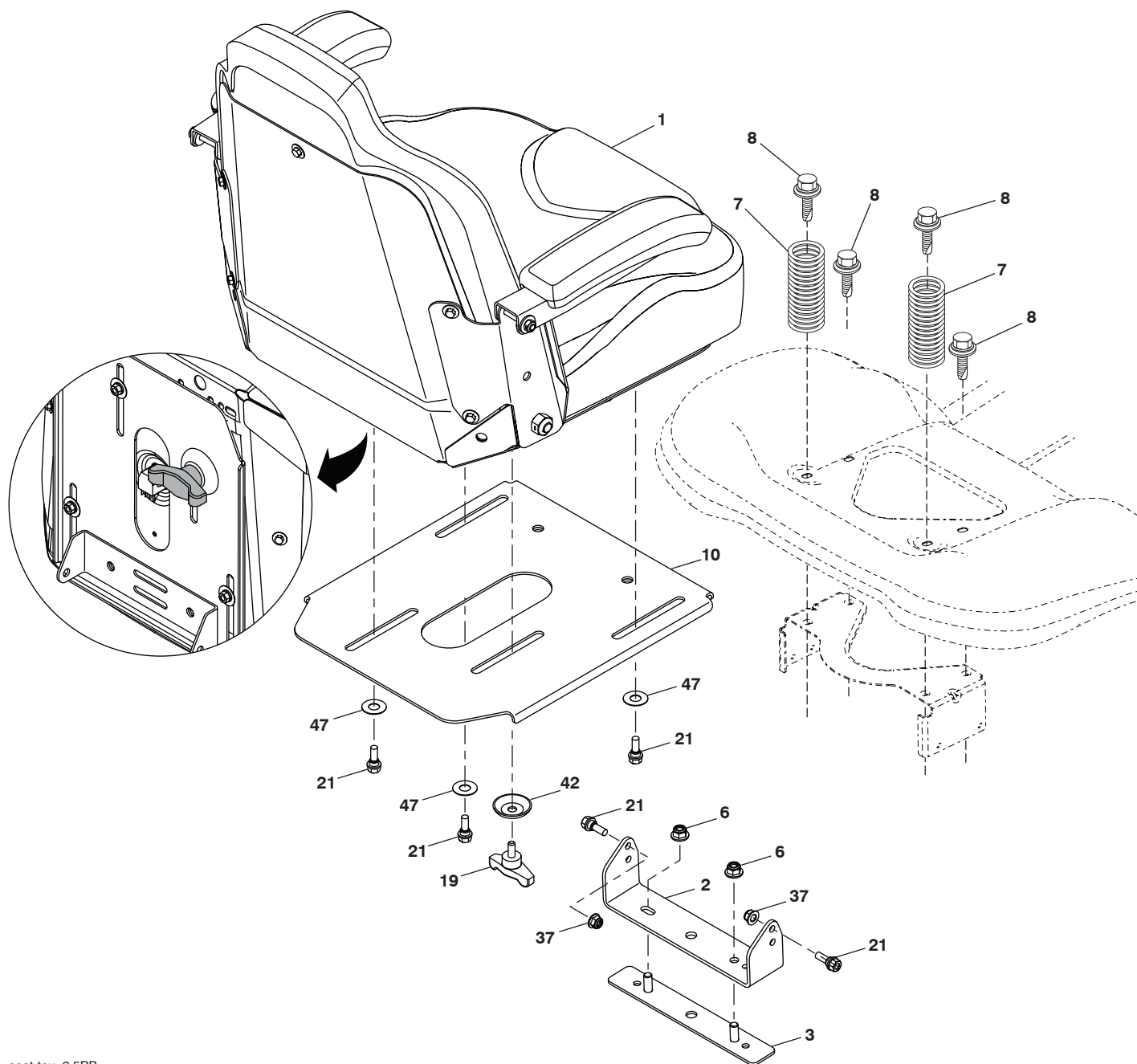

seat-tex_6.5PB

CÓDIGO No.	PIEZA No.	DESCRIPCIÓN
1	590 33 73-02	Asiento
2	590 33 66-02	Soporte pivotante del guardabarros
3	590 77 76-02	Soporte pivotante del Asiento
6	521 99 65-01	Tuerca 3/8-16
7	590 81 23-01	Resorte del asiento
8	532 17 18-77	Perno 5/16-18 unc x 3/4
10	590 48 17-02	Bandeja del asiento
19	590 69 15-01	Perilla
21	532 16 96-12	Perno 5/16-18 x 5/8

CÓDIGO No.	PIEZA No.	DESCRIPCIÓN
37	539 11 28-99	Tuerca 5/16-18 unc
42	532 19 93-71	Arandela
47	590 35 11-01	Arandela de .50 x 1.12 x .033

NOTA: Las dimensiones de todos los componentes están expresadas en pulgadas americanas. 1 pulgada = 25,4 mm

TRACTOR MODELO NO. TS 354XD (96043024500), PRODUCTO NO. 960 43 02-45

CALCOMANÍAS

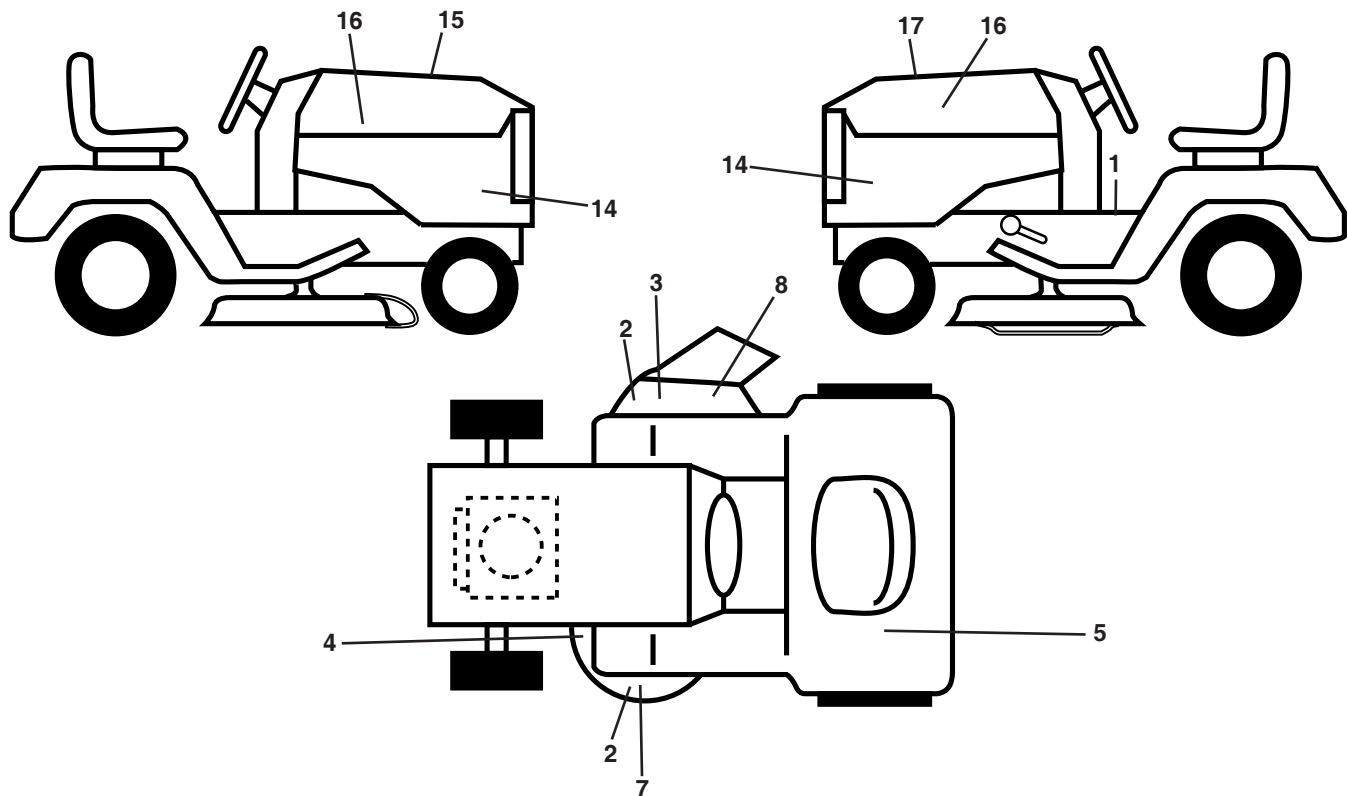

CÓDIGO No.	PIEZA No.	DESCRIPCIÓN
1	581 57 89-01	Calcomanía, Advertencia
2	589 35 79-01	Calcomanía, Ningún paso
3	581 58 00-02	Calcomanía del diagrama de la cortadora de césped
4	592 89 83-01	Calcomanía, Plataforma de la cortadora de césped Garantía
5	587 01 51-01	Calcomanía, Reserva de combustible
7	590 88 50-01	Calcomanía, Plataforma de la cortadora de césped Clearcut
8	586 97 88-01	Calcomanía, Advertencia
14	591 44 85-01	Calcomanía, Panel
15	532 42 38-29	Calcomanía
16	581 62 73-01	Calcomanía para la capota, logo
17	589 62 66-01	Calcomanía de reemplazo

CÓDIGO No.	PIEZA No.	DESCRIPCIÓN
--	581 57 90-01	Calcomanía, Guardabarros Advertencia (Inglés/ Francés)
--	581 72 48-01	Calcomanía para la desviación
--	586 74 22-01	Calcomanía reserva de combustible (Inglés/ Francés)
--	532 43 98-82	Forro del apoyo para los pies izquierdo
--	532 43 98-81	Forro del apoyo para los pies derecho
--	115 99 43-49	Manual del operario (Inglés/Español)
--	115 99 46-32	Manual del operario (Francés)
--	115 99 44-49	Manual de repuestos (Inglés/Español)
--	115 99 45-32	Manual de repuestos (Francés)
--	587 71 00-26	Manual de QSG (Inglés/Español)
--	587 71 01-26	Manual de QSG (Inglés/Francés)

WHEELS AND TIRES

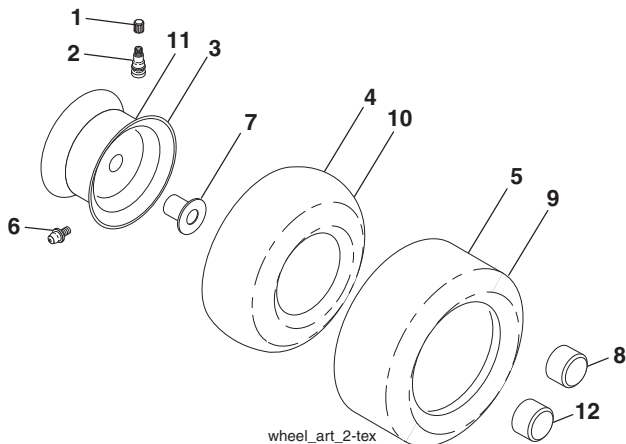

CÓDIGO No.	PIEZA No.	DESCRIPCIÓN
1	532 05 91-92	Tapa de la válvula del neumático
2	532 06 51-39	Vástago de la válvula
3	532 18 18-39	Ensamble de las llantas delanteras
4	532 00 81-34	Cámara delantera
5	593 14 51-01	Neumático delantero 16 x 6.5-8
6	532 12 49-57	Accesorio para engrasar (solo para la rueda delantera)
7	532 12 49-59	Rodamiento de la brida (solo para la rueda delantera)
8	532 17 50-39	Tapa del eje frente
9	593 14 52-01	Neumático trasero 23 x 10.5-12
10	532 00 71-54	Cámara trasera (Mantenimiento sólo)
11	593 14 48-01	Ensamble trasero de la llanta
12	501 50 31-01	Tapa del eje trasero negro
--	532 14 43-34	Sellador para neumáticos (tubo de 10 onzas [283 gr])

NOTA: Las dimensiones de todos los componentes están expresadas en pulgadas americanas. 1 pulgada = 25,4 mm

NOTES/AVISO



www.husqvarna.com