

Repair Parts Manual
Manual De Repuestos
YT48XLS / 96043015600

Please read the operator's manual carefully and make sure you understand the instructions before using the machine.

Por favor lea cuidadosamente y comprenda estas instrucciones antes de usar esta maquina.



English/Spanish

581 53 64-27 Rev. 8



HOW TO USE THIS MANUAL

This manual is designed to provide the customer with a means to identify the parts on his/her tractor when ordering repair parts. The illustrations may or may not represent the actual assemblies; therefore, it is not recommended to use this manual as a guide to assemble or disassemble the tractor. Some hardware and parts are drawn larger in order to more readily identify them.

Each tractor has its own model number.

The model number for your tractor can be found on the fender under the seat.

When ordering parts, always give the following information:

- Product - "TRACTOR"
- MODEL NUMBER - "YT48XLS" (96043015600)"
- Part Number
- Part Description

TABLE OF CONTENTS

SCHEMATIC	3
ELECTRICAL.....	4-5
CHASSIS	6-7
DRIVE.....	8-9
ENGINE.....	10-11
STEERING	12-13
MOWER DECK.....	14-15
MOWER LIFT.....	16
SEAT	17
DECALS.....	18

COMO UTILIZAR ESTE MANUAL

Este manual está diseñado para brindarle al comprador un medio para identificar las piezas del tractor para cuando necesite hacer el pedido de un repuesto. Las ilustraciones pueden o no representar los ensambles reales; por lo tanto, no se recomienda utilizar este manual como una guía para ensamblar o desarmar el tractor. Algunos accesorios y piezas están dibujados en tamaños más grandes para identificarlos con mayor facilidad.

Cada tractor tiene su propio número de modelo.

El número de modelo del tractor se encuentra en el guardabarros debajo del asiento.

Cuando haga el pedido de una pieza, siempre brinde la siguiente información:

- Producto: "TRACTOR"
- NÚMERO DE MODELO: "YT48XLS" (96043015600)"
- Número de pieza
- Descripción de la pieza

ÍNDICE

DIAGRAMA.....	19
DIAGRAMA ELÉCTRICO	20-21
CHASIS.....	22-23
TRANSMISIÓN	24-25
MOTOR	26-27
DIRECCIÓN	28-29
PLATAFORMA DE LA CORTADORA DE CÉSPED.....	30-31
ELEVACIÓN DE LA CORTADORA DE CÉSPED.....	32
ASIENTO.....	33
CALCOMANÍAS.....	34

TRACTOR - MODEL NO. YT48XLS (96043015600), PRODUCT NO. 960 43 01-56 SCHEMATIC

SCH12

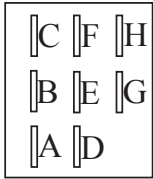
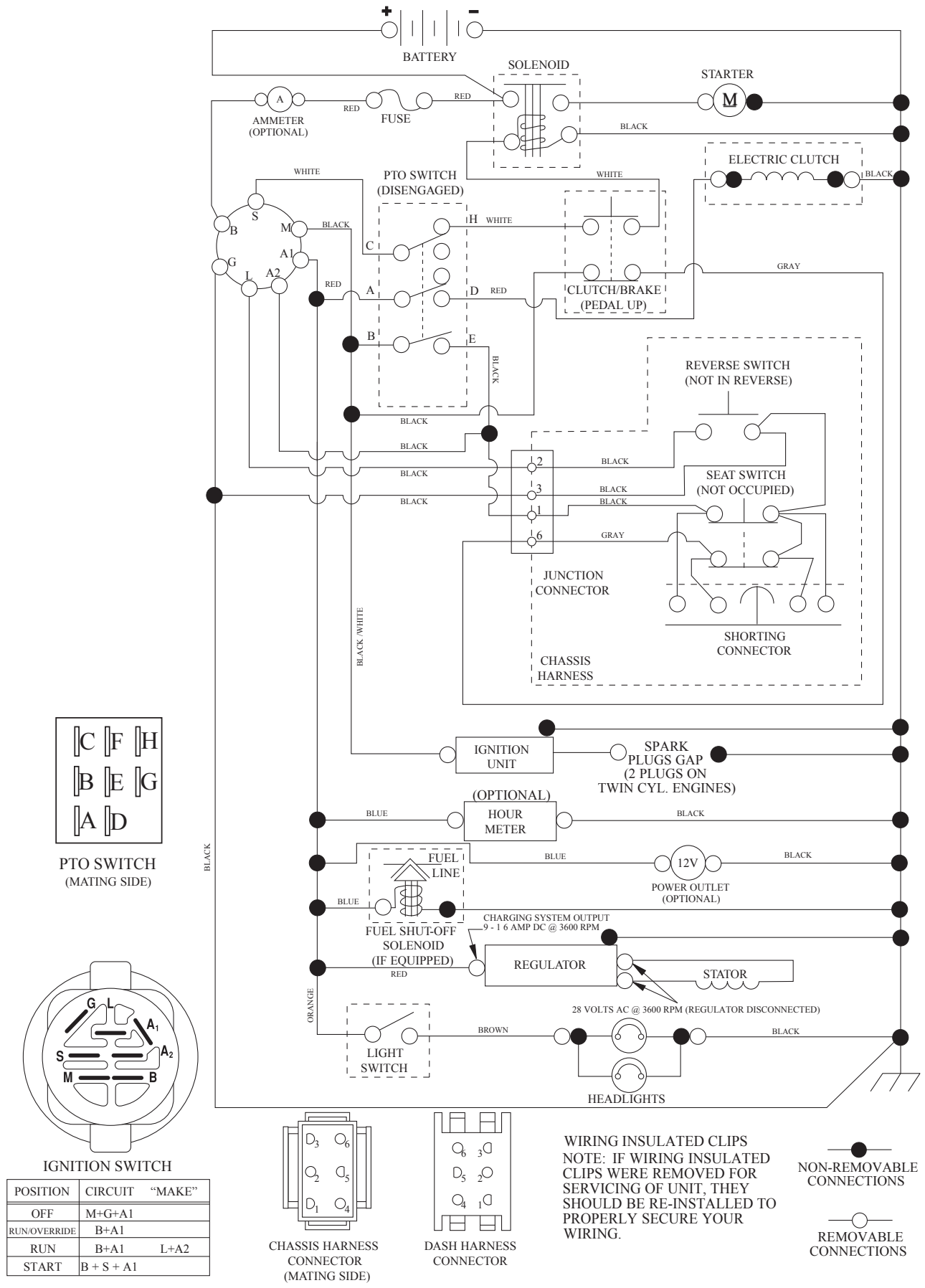

PTO SWITCH
(MATING SIDE)

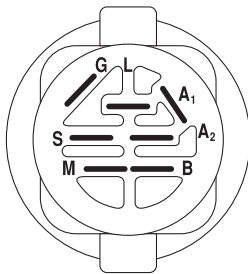

IGNITION SWITCH

POSITION	CIRCUIT	"MAKE"
OFF	M+G+A1	
RUN/OVERRIDE	B+A1	
RUN	B+A1	L+A2
START	B + S + A1	

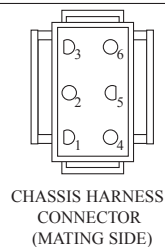

CHASSIS HARNESS
CONNECTOR
(MATING SIDE)

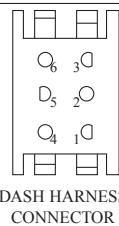

DASH HARNESS
CONNECTOR

WIRING INSULATED CLIPS
NOTE: IF WIRING INSULATED
CLIPS WERE REMOVED FOR
SERVICING OF UNIT, THEY
SHOULD BE RE-INSTALLED TO
PROPERLY SECURE YOUR
WIRING.

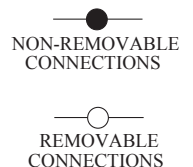

**TRACTOR - MODEL NO. YT48XLS (96043015600), PRODUCT NO. 960 43 01-56
ELECTRICAL**

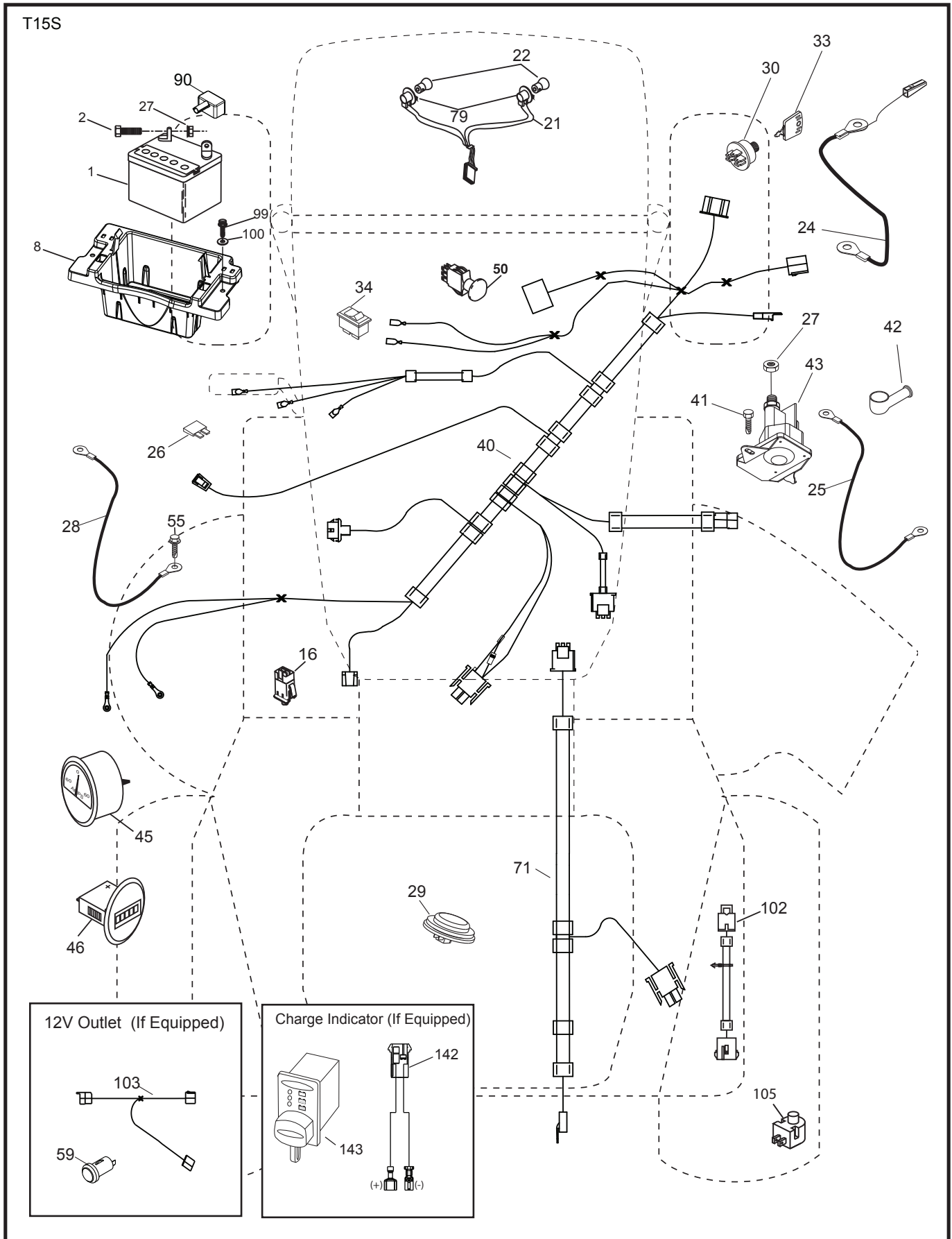

**TRACTOR - MODEL NO. YT48XLS (96043015600), PRODUCT NO. 960 43 01-56
ELECTRICAL**

KEY NO.	PART NO.	DESCRIPTION
1	532 16 34-65	Battery
2	874 76 04-12	Bolt Hex Head 1/4-20 x 3/4
8	532 41 41-26	Box Battery
16	532 17 61-38	Switch Interlock Push-In
21	532 40 02-52	Harness Socket Light w/4152J
22	532 00 41-52	Bulb Light
24	532 40 02-53	Cable Battery
25	532 41 28-95	Cable Starter
26	532 17 51-58	Fuse
27	873 51 04-00	Nut Keps Hex 1/4-20 unc
28	532 14 54-91	Cable, Ground
29	532 40 15-45	Switch, Seat
30	532 19 33-50	Switch, Ign
33	532 41 19-33	Key\Chain
34	532 11 07-12	Switch Light / Reset
40	581 58 35-01	Harness Ign. Dash
41	817 72 04-08	Screw Thd Cut 1/4-20 x 1/2
42	532 13 15-63	Cover, Terminal
43	532 19 25-07	Solenoid
45	532 42 52-70	Ammeter Gauge Round
46	532 42 52-71	Hourmeter
50	532 17 46-51	Switch PTO
55	817 06 05-12	Screw Thdrol 5/16-18 x 3/4 TYTT
59	532 40 03-03	Outlet 12-Volt
71	532 19 42-76	Harness Chassis
79	532 17 52-42	Socket Asm Bulb Twistlock
90	532 43 53-95	Cover Terminal
91	532 19 02-70	Strap Battery Mount
99	817 67 04-12	Screw Hexwsh Thdrol 1/4-20 x 3/4
100	819 09 14-16	Washer 9/32 x 7/8 x 16 Ga.
102	532 40 44-54	Harness Pigtail
103	532 42 17-47	Harness 12-Volt Pigtail
105	532 40 75-68	Switch Reverse TT Pedal Control
142	532 44 80-57	Harness Charge Port

NOTE: All component dimensions given in U.S. inches
1 inch = 25.4 mm

**TRACTOR - MODEL NO. YT48XLS (96043015600), PRODUCT NO. 960 43 01-56
CHASSIS**

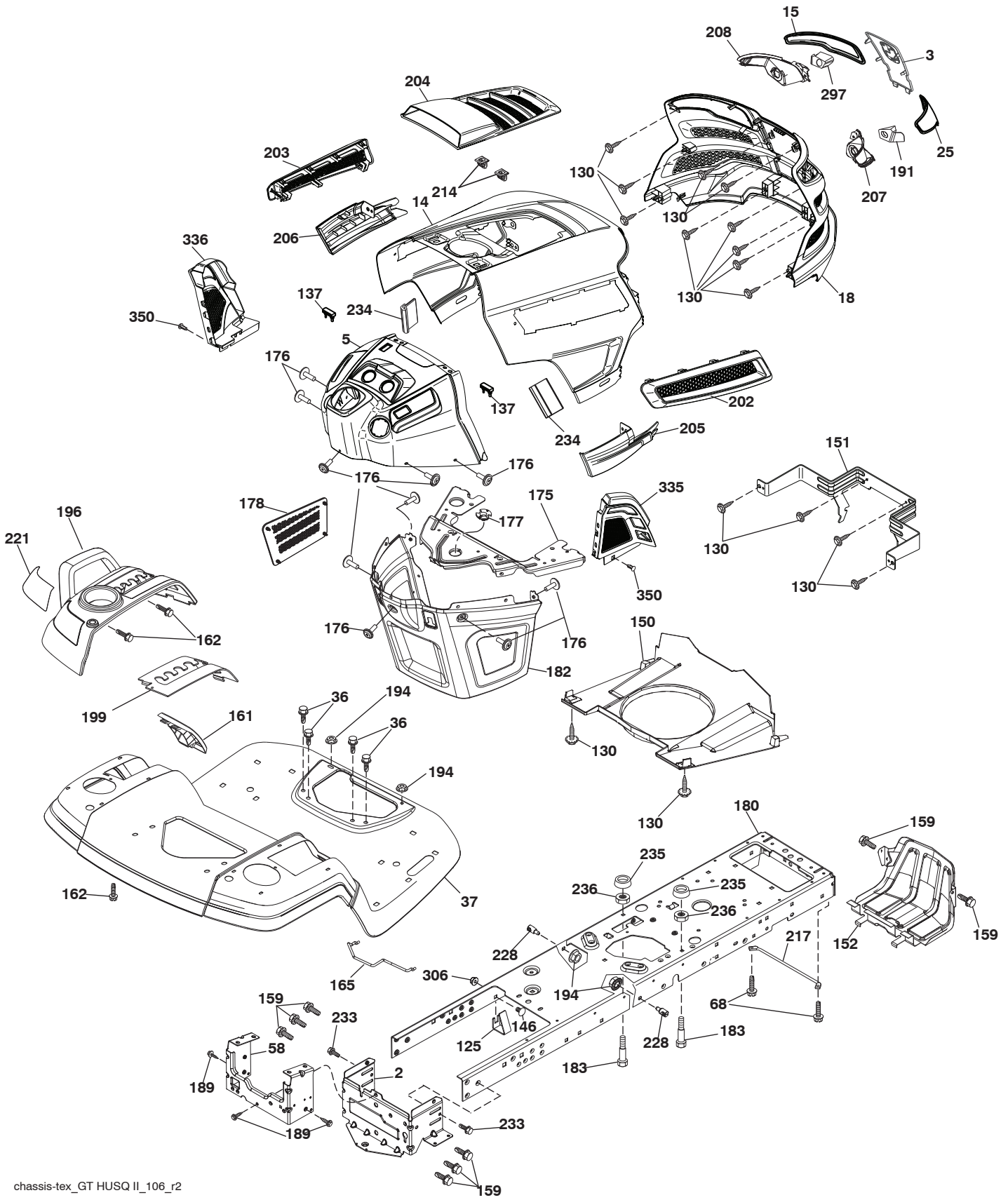

chassis-tex_GT HUSQ II_106_r2

**TRACTOR - MODEL NO. YT48XLS (96043015600), PRODUCT NO. 960 43 01-56
CHASSIS**

KEY NO.	PART NO.	DESCRIPTION
2	532 41 22-82	Drawbar Lower
3	532 44 44-81	Applique
5	532 43 74-90	Dash
14	532 44 11-77	Hood
15	532 43 97-33	Lens LH
18	532 44 06-53	Grille
25	532 44 33-85	Lens RH
36	817 06 05-12	Screw 5/16-18 x 3/4
37	532 44 12-08	Fender
58	532 41 22-81	Drawbar Upper
68	817 49 05-08	Screw Thdrol 5/16-18 x 1/2
125	581 68 48-01	Clip Fuel Line
130	532 41 63-58	Screw 10 x .750 BOS Thread
137	532 40 75-90	Bumper Dash
146	581 85 79-01	Bolt
150	532 43 97-74	Air Duct
151	532 43 66-70	Bracket Pivot Hood
152	532 43 98-70	Shield Browning
159	817 00 06-12	Screw 3/8-16 x 3/4
161	532 43 99-29	Window, Fuel
162	532 14 24-32	Screw Hex Wsh 1/4 x 1/2 unc
165	532 19 43-30	Support Tank Rear
175	532 19 63-04	Crossmember
176	532 40 07-76	Screw 10-24 x 5/8
177	532 19 52-27	Bushing Steering
178	532 19 97-82	Cargo Net Asm.
180	532 44 55-59	Chassis
182	532 40 68-59	Dash Lower
183	874 52 05-20	Bolt 5/16-18 x1-1/4

KEY NO.	PART NO.	DESCRIPTION
189	817 00 05-12	Screw 5/16-18 x 3/4
191	532 43 74-55	Insert Reflective RH
194	873 90 05-00	Nut Lock Hex Flange 5/16-18
196	532 43 96-74	Console Asm. Deck Lift
199	532 19 82-59	Plate Deck Lift
202	532 43 97-28	Vent Side Hood RH
203	532 43 97-27	Vent Side Hood LH
204	532 43 57-14	Vent Top Hood
205	532 43 97-30	Skirt Hood Side RH
206	532 43 97-29	Skirt Hood Side LH
207	532 43 97-34	Bezel RH
208	532 43 97-35	Bezel LH
214	532 19 91-45	Clip Retainer Tinner
217	532 40 91-67	Rod Pivot
221	532 19 89-09	Reflector LH
228	532 19 51-61	Stud Fastner
233	532 19 65-39	Bolt, Shoulder
234	532 40 47-42	Bumper Hood
235	532 40 61-29	Spacer Fender
236	873 93 05-00	Nut Lock 5/16-18 unc
297	532 43 74-56	Insert Reflective LH
306	873 90 06-00	Nut Lock
335	532 44 82-04	Cover RH Lower Close Out
336	532 44 53-09	Cover LH Lower Close Out
350	532 44 51-43	Clip X-mas Tree
--	532 43 18-82	Kit Guard Brush

NOTE: All component dimensions given in U.S. inches
1 inch = 25.4 mm

TRACTOR - MODEL NO. YT48XLS (96043015600), PRODUCT NO. 960 43 01-56 DRIVE

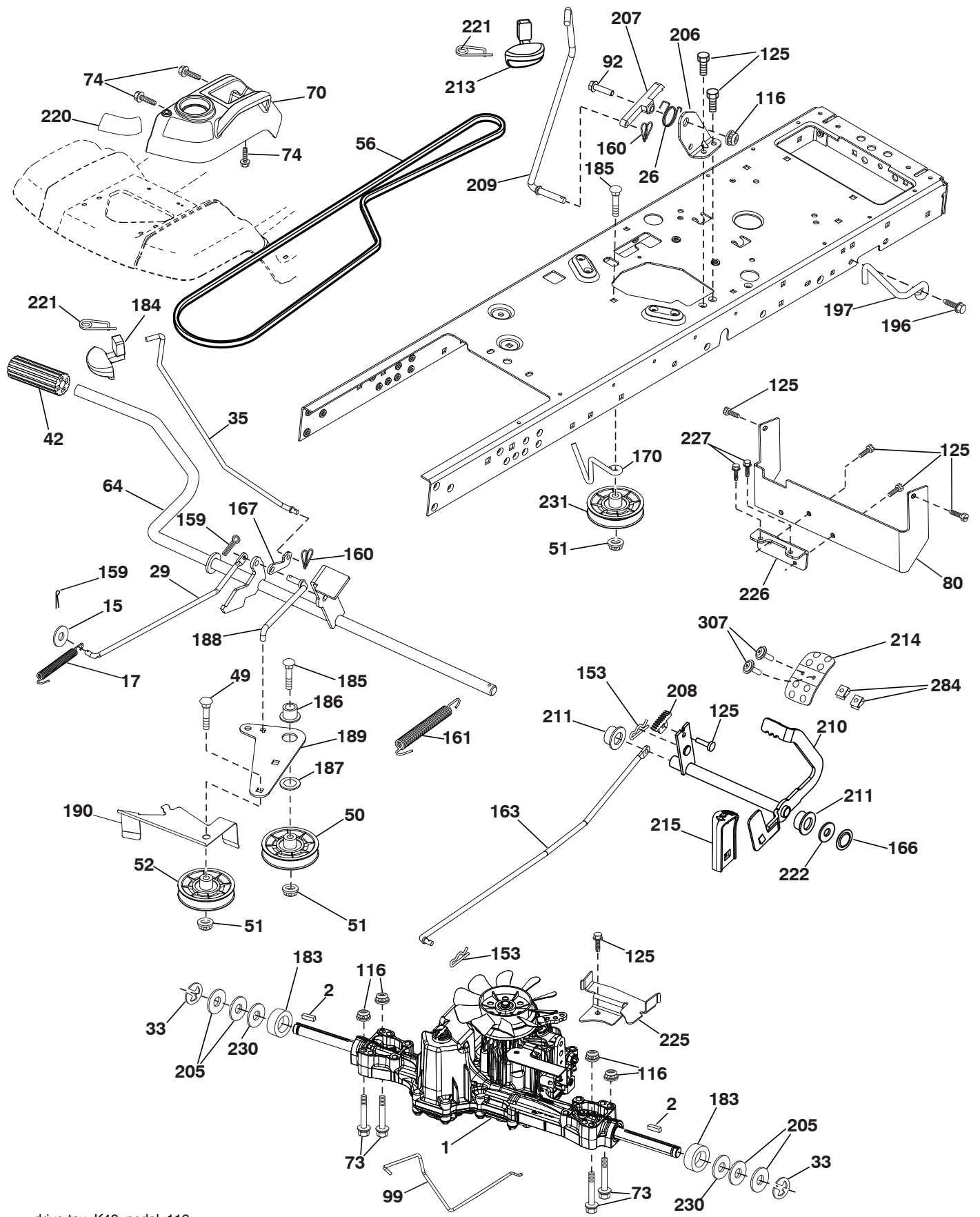

drive-tex_K46_pedal_112

**TRACTOR - MODEL NO. YT48XLS (96043015600), PRODUCT NO. 960 43 01-56
DRIVE**

KEY NO.	PART NO.	DESCRIPTION	KEY NO.	PART NO.	DESCRIPTION
1	---	Transaxle, TUFFTORQ K46 CR/LD (426121) (Order parts from trans-axle manufacturer.)	184	532 44 14-55	Handle Parking Brake
2	532 12 35-83	Key	185	872 11 06-22	Bolt Rdhd Sqnk 3/8-16 x 2-3/4 Gr. 5
15	819 13 13-16	Washer 13/32 x 13/16 x 16 Ga.	186	532 19 43-21	Spacer Retainer
17	532 41 36-78	Spring, Brake	187	819 13 32-10	Washer
26	532 19 96-79	Spring Return Cruise	188	532 19 43-23	Link Clutch Ground Drive
29	532 40 38-06	Rod, Brake	189	532 19 43-17	Bellcrank Ground Drive
33	812 00 00-01	Ring E	190	532 19 43-18	Keeper Bellcrank Ground Drive
35	583 86 45-01	Rod, Brake, Park	196	817 00 06-16	Screw 3/8-16 x 1
42	532 12 48-72	Cover, Foot Pedal	197	585 65 86-01	Bracket Clutch Anti-Rotation
49	872 11 06-14	Bolt	205	532 12 17-48	Washer
50	532 19 43-27	Pulley Idler Flat	206	532 19 78-67	Bracket Mount Latch Cruise
51	873 90 06-00	Lock Nut 3/8-16	207	532 19 78-68	Latch Control Cruise
52	532 19 43-26	Idler V-Groove	208	532 19 78-69	Gear Sector Control Cruise
56	532 13 09-69	V-Belt, Drive	209	532 19 95-92	Rod Control Cruise
64	532 19 78-65	Shaft Asm. Pedal Brake Control	210	532 19 78-60	Rocker Asm. Pedal Control
70	532 43 96-61	Console Asm	211	532 12 01-83	Bearing Nylon
73	874 49 05-40	Bolt 5/16-18 x 2-1/2 Gr. 5	213	532 40 31-19	Knob Control Cruise
74	532 14 24-32	Screw Hex Wsh Hi-Lo 1/4 x 1/2 unc	214	532 41 68-63	Pedal Forward
80	532 44 06-19	Bracket Strap Torque	215	532 40 17-23	Pedal Reverse
92	874 76 05-20	Bolt Fin Hex 5/16-18 unc x 1.25	220	532 19 89-08	Reflector RH
99	532 41 57-42	Rod Spring Bypass	221	532 40 31-87	Retainer Spring Clip Handle
116	873 90 05-00	Nut Lock Hex Flange 5/16-18	222	879 21 20-10	Washer 21/32 x 1-1/4 x 10 Ga.
125	817 00 05-12	Screw 5/16-18 x 3/4	225	532 40 33-19	Keeper Belt Trans.
153	532 12 47-88	Retainer Spring	226	532 40 15-64	Bracket Mount Touque
159	876 02 04-12	Pin Cotter 1/8 x 3/4	227	817 49 05-12	Screw 5/16-18 x 3/4
160	532 16 94-84	Retainer Clip	230	532 18 89-67	Washer Hardened
161	532 10 57-09	Spring, Return, Clutch	231	532 40 72-87	Idler V-Groove
163	532 44 82-75	Rod Pedal Control	284	532 41 76-93	Nut U CHNL 1/4-20 550DP .350 PNL
166	532 42 91-64	Nut Push	307	874 18 04-12	Screw Mach. CR. 1/4-20 x 3/4
167	532 40 52-57	Latch Brake Parking			
170	532 41 34-30	Keeper Belt Centerspan			
183	532 13 70-57	Spacer Split			

NOTE: All component dimensions given in U.S. inches
1 inch = 25.4 mm

**TRACTOR - MODEL NO. YT48XLS (96043015600), PRODUCT NO. 960 43 01-56
ENGINE**

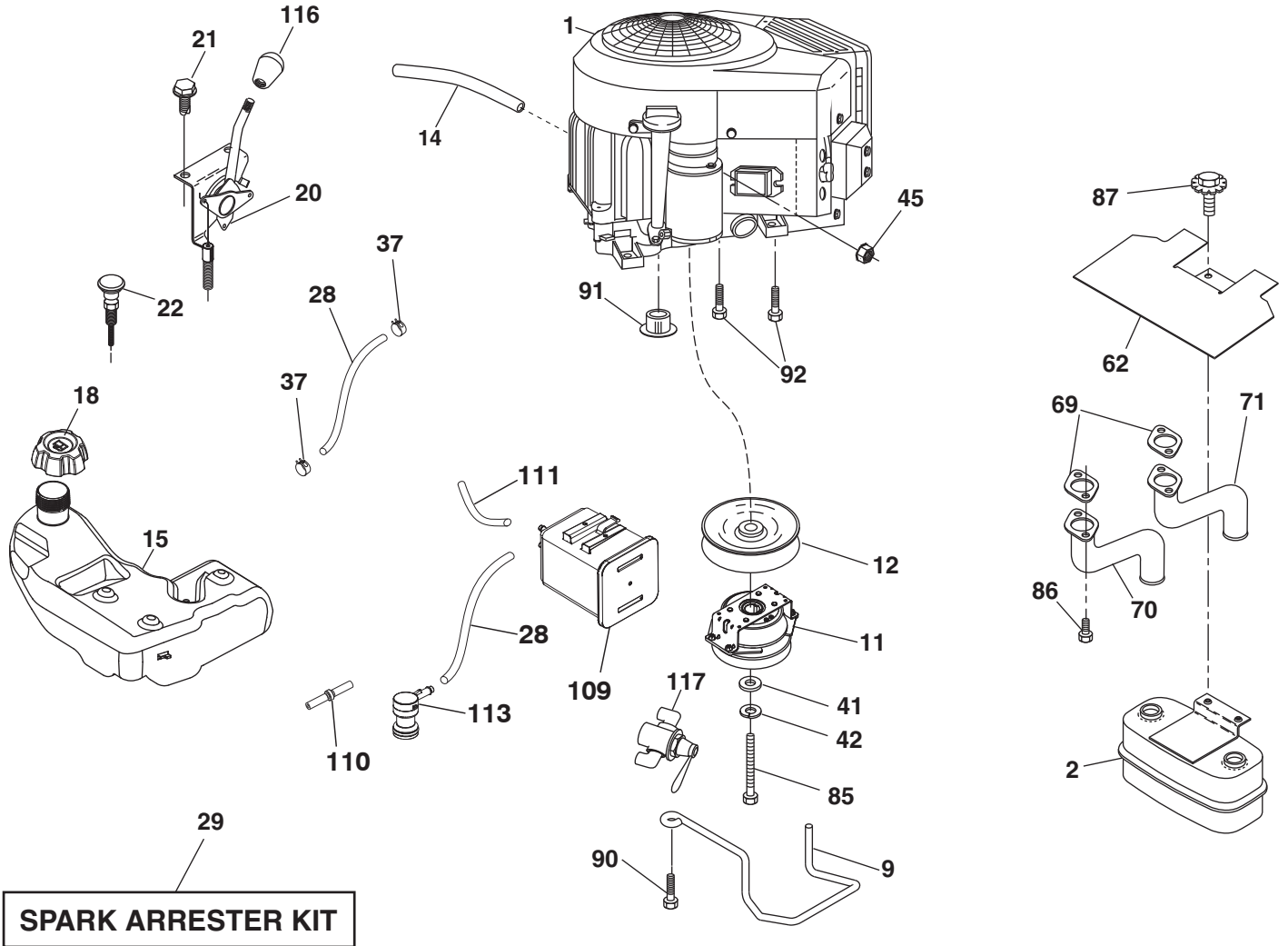

engine-tex_Kawa-2cyl_41

**TRACTOR - MODEL NO. YT48XLS (96043015600), PRODUCT NO. 960 43 01-56
ENGINE**

KEY NO.	PART NO.	DESCRIPTION
1	-----	Engine Kawasaki No. FR730V-AS12 (445364) (Order parts from engine manufacturer.)
2	532 44 59-62	Muffler
9	532 19 43-20	Keeper Belt Engine
11	587 24 16-01	Clutch
12	532 40 50-97	Pulley Engine
14	532 14 84-56	Tube Drain Oil Easy
15	532 42 07-23	Tank Fuel
18	532 43 92-08	Cap Asm
20	532 42 43-41	Control Throttle
21	532 41 63-58	Screw #10 x .750 BOS Thread
22	532 18 77-67	Control Choke
28	532 40 11-35	Fuel Line
29	532 13 71-80	Spark Arrester Kit
37	532 12 34-87	Clamp Hose
41	532 12 61-97	Washer 1-1/2 OD x 15/32 ID x .250
42	810 04 07-00	Washer Lock 7/16
45	873 51 04-00	Nut Keps Hex 1/4-20 unc
62	532 43 40-17	Heat Shield
69	532 17 81-51	Gasket
70	532 42 47-65	Tube Exhaust LH
71	532 42 47-66	Exhaust Tube RH
85	532 17 99-53	Bolt Hex 7/16-20 x 3.75 Gr.
86	532 18 43-62	Nut Hex Flg. Toplock M8-1.25
87	537 17 18-77	Bolt 5/16-18 unc x 3/4 w/Sems
90	817 00 06-16	Screw 3/8-16 x 1
91	532 18 74-95	Bushing
92	817 12 06-16	Screw 3/8-16 x 1
109	532 41 41-14	Canister Carbon Filter
110	532 41 41-18	Valve Asm Anti Slosh
111	532 42 07-18	Purge Line Carb 3/16
113	532 41 41-27	Valve Slant Cartridge
116	539 13 26-24	Knob Soft Touch
117	532 42 08-28	Valve Fuel Reserve

NOTE: All component dimensions given in U.S. inches
1 inch = 25.4 mm

For engine service and replacement parts, call the toll free number for your engine manufacturer listed below:

Kawasaki 1-949-460-5688

TRACTOR - MODEL NO. YT48XLS (96043015600), PRODUCT NO. 960 43 01-56
STEERING ASSEMBLY

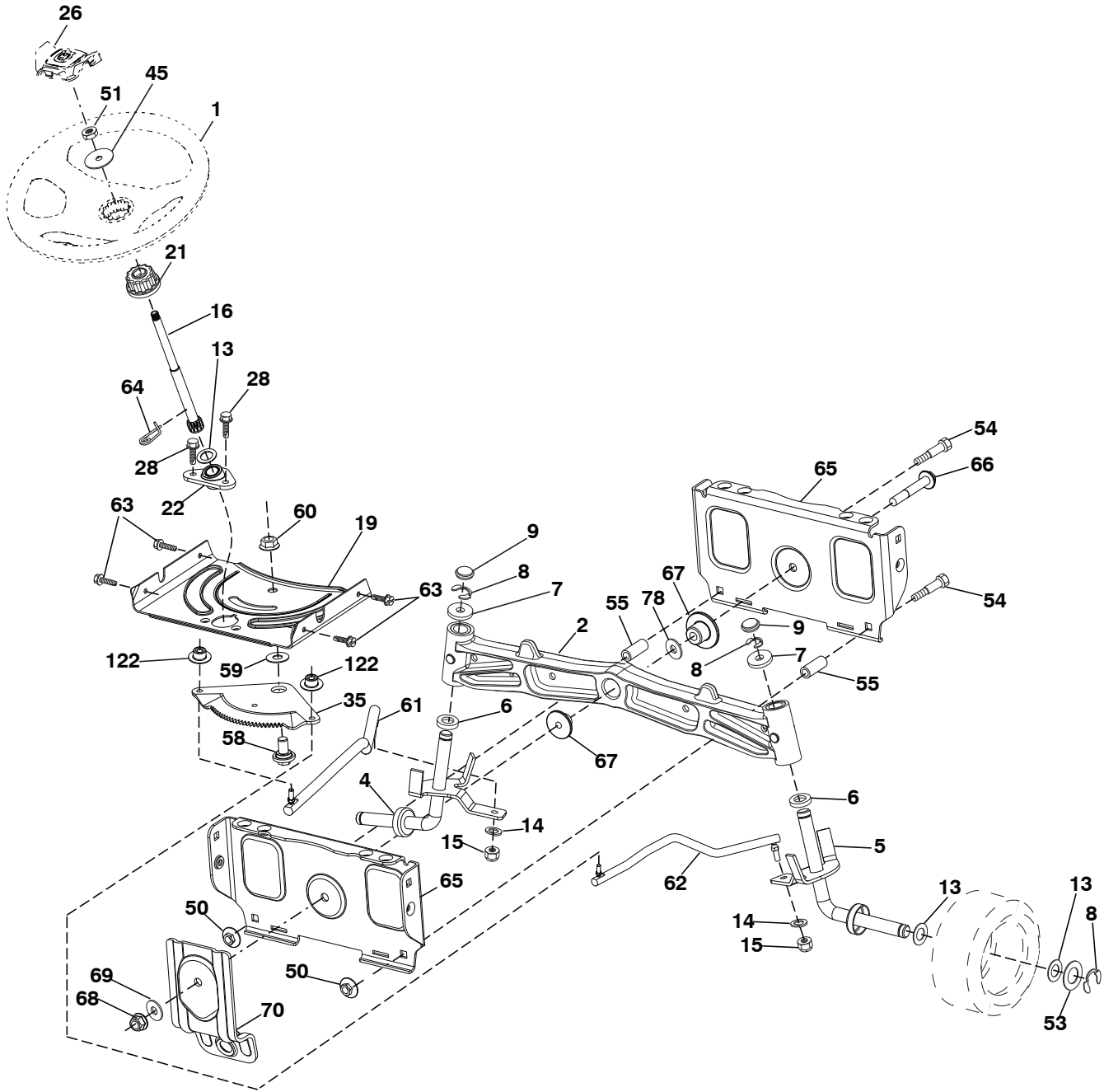

steering-tex_HUSQSR_30

**TRACTOR - MODEL NO. YT48XLS (96043015600), PRODUCT NO. 960 43 01-56
STEERING ASSEMBLY**

KEY NO.	PART NO.	DESCRIPTION
1	532 43 97-40	Wheel, Steering
2	532 19 59-68	Axle Asm., Front
4	532 40 30-89	Spindle Asm., LH
5	532 40 30-90	Spindle Asm., RH
6	532 12 49-31	Bearing, Race Thrust Harden
7	532 12 17-48	Washer 25/32 x 1-5/8 x 16 Ga.
8	812 00 00-29	Ring, Klip #T5304-75
9	532 12 12-32	Cap, Spindle
13	532 12 17-49	Washer 25/32 x 1-1/4 x 16 Ga.
14	810 04 06-00	Washer, Lock Hvy Hlcl Spr 3/8
15	873 54 06-00	Nut, Crown Lock 3/8-24 unf
16	532 40 82-19	Shaft Steering
19	532 19 47-29	Plate Steering
21	532 18 67-37	Adapter, Wheel Steering
22	532 42 05-37	Steering Support Lower
26	532 43 97-43	Insert, Wheel Steering
28	817 00 06-12	Screw 3/8-16 x 3/4
35	532 19 47-32	Gear, Sector Plate
45	819 18 38-12	Washer 9/16 ID x 2-3/8 OD 12 Ga.
50	873 90 06-00	Nut Lock Flg. 3/8-16
51	873 94 08-00	Nut Hex Jam Toplock 1/2-20 unf
53	532 18 89-67	Washer Hardened .793 x 1.637 x .060
54	874 76 06-36	Bolt Hex 3/8-16 x 2-1/4
55	532 41 47-36	Spacer Axle Brace
58	532 19 47-47	Bolt Shoulder Sector Pivot CFM
59	532 19 47-48	Washer Thrust Sector Steering
60	873 97 10-00	Nut Flange Lock 5/8-11
61	532 19 47-40	Draglink LH
62	532 19 47-41	Draglink, RH
63	817 00 05-12	Screw 5/16-18 x 3/4
64	532 19 98-49	Retainer Clip Spring Steering
65	532 19 47-34	Brace Axle Front
66	871 02 07-48	Bolt Hex Fghd 7/16-14 x 3 Serr
67	532 19 47-37	Bushing Front Axle
68	873 90 07-00	Nut Lock Flange 7/16-14 Gr. 5
69	532 19 91-62	Washer 1.5 x .505 x .118
70	532 19 61-97	Bracket Deck Susp. Front
78	532 05 70-79	Washer Thrust
122	532 44 49-62	Cap Gear Sector

NOTE: All component dimensions given in U.S. inches
1 inch = 25.4 mm

**TRACTOR - MODEL NO. YT48XLS (96043015600), PRODUCT NO. 960 43 01-56
MOWER DECK**

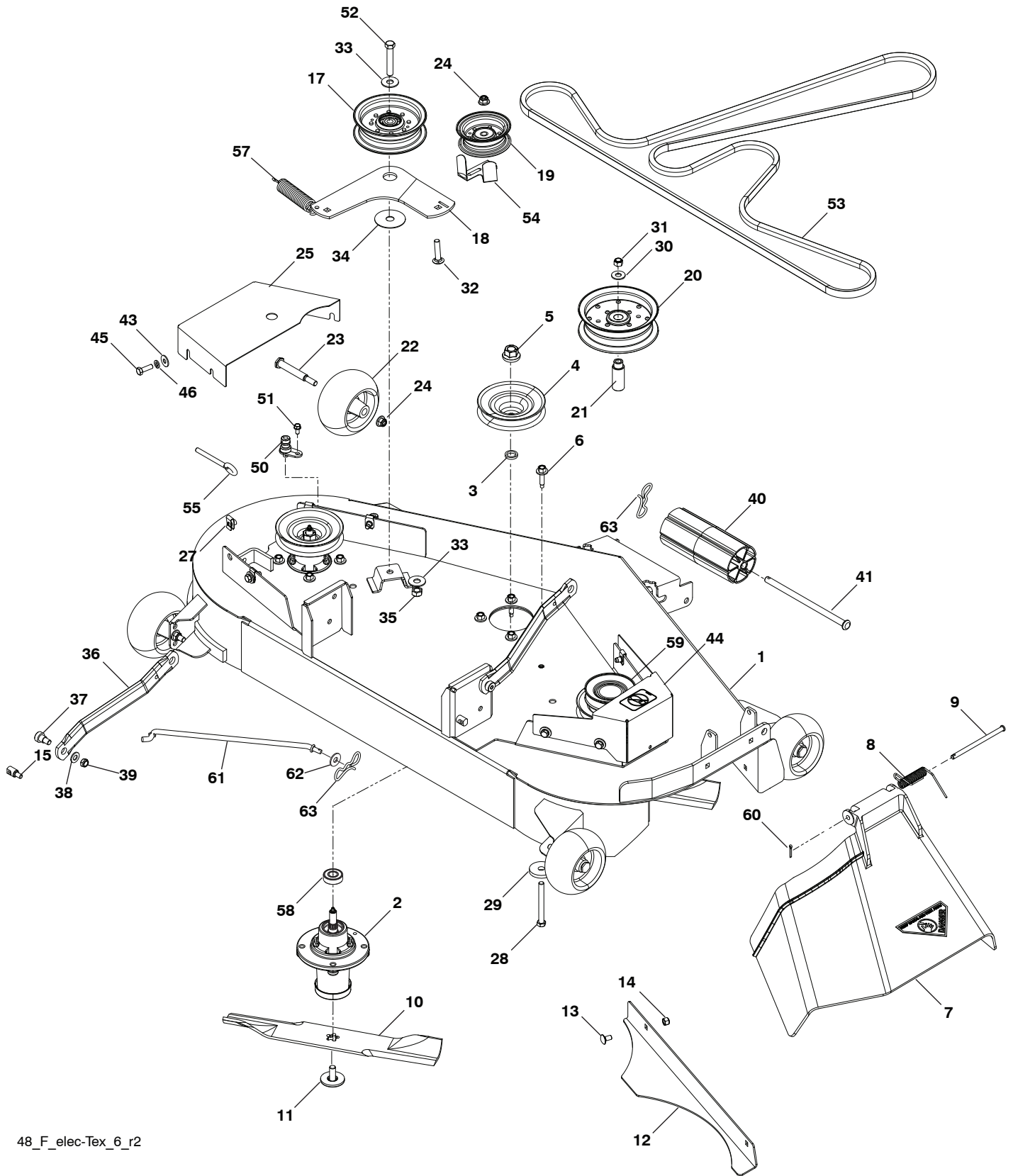

48_F_elec-Tex_6_r2

**TRACTOR - MODEL NO. YT48XLS (96043015600), PRODUCT NO. 960 43 01-56
MOWER DECK**

KEY NO.	PART NO.	DESCRIPTION	KEY NO.	PART NO.	DESCRIPTION
1	594 74 20-01	Deck	36	532 19 51-85	Arm, Susp., Rear
2	539 11 21-70	Housing Assembly	37	539 11 36-21	Sb 3/8-16 x 3/8 Skt Hd
3	532 18 76-90	Washer-Spacer	38	819 13 13-16	Washer 13/32 x 13/16 x 16 Ga.
4	532 17 43-75	Pulley, Mandrel	39	539 20 02-82	Nut, 3/8-16 Hex Jam Nyloc
5	532 40 02-34	Nut Flange Lock Top	40	532 17 60-66	Roller, Nose, 48"
6	532 17 39-84	Screw Thdrol	41	532 17 91-27	Rod, Roller, Nose, Narrow
7	539 11 07-32	Discharge Chute, 48"	43	819 12 14-14	Washer 3/8 x 7/8 x 14 Ga.
8	539 11 07-35	Spring - Torsion	44	575 96 72-02	Shield, Belt RH
9	539 11 07-36	Pin, Clevis 5/16 x 5.19	45	874 78 05-16	Bolt Fin Hex 5/16-18 unc x 1
10	539 11 34-25	Blade, 16-1/4"	46	810 03 05-00	Wash 5/16 Slw
11	532 19 30-03	Bolt Washer Assy 7/16-20	50	532 41 55-98	Washout Port
12	539 11 34-26	Confinement Plate	51	817 49 04-08	Screw Hexwash Thdrol 1/4-20 x 1/2
13	872 11 05-05	Rhsnb 5/16-18 x 5/8 Gr 5	52	874 78 07-40	Hcs 7/16-14 x 2-1/2 Gr 5
14	873 80 05-00	Nut Lock Hex w/ Ins. 5/16-18 unc	53	574 84 56-02	Belt, Deck
15	532 19 51-61	Stud, Fasten w/ Anti- Rotate	54	532 14 10-43	Guard, Belt
17	532 19 61-04	Pulley, Idler Spec. Hub	55	539 11 55-74	Eyebolt 5/16 x 3-1/2
18	574 82 71-01	Arm Idler	57	539 10 68-50	Spring
19	532 17 79-68	Pulley, Idler	58	532 11 04-85	Ball Bearing
20	539 13 27-28	Pulley, Idler	59	575 35 29-01	Pulley
21	575 22 45-01	Idler Bushing	60	532 16 94-84	Clip Retainer Dia. 290
22	532 13 39-57	Wheel, Gauge	61	532 40 48-51	Rod Anti Sway
23	532 19 34-06	Bolt Shoulder 3/8-16 x 3-5/8	62	819 13 13-12	Washer 13/32 x 13/16 x 12 Ga.
24	521 99 65-01	Nut 3/8-16 Hex Flg Nyloc	63	532 19 42-08	Pin Cotter 5/16
25	575 22 47-02	Shield, Belt LH	--	532 41 64-05	Connect Quick Coupling
27	539 10 47-63	Retainer 5/16c U Type	--	594 74 20-01	Service Deck
28	539 10 82-71	Hcs 3/8-16 x 3-1/2 Gr 5			
29	539 10 65-04	Heavy Washer			
30	819 14 16-14	Washer, 3/8 Flat Std			
31	539 97 69-79	Nut 3/8-16 Hex Nyloc			
32	539 99 09-23	Rhsnb 3/8-16 x 1-3/4 Gr 5			
33	539 10 48-64	Washer, 7/16 Flat			
34	532 17 85-15	Washer, Flat Hardened			
35	873 90 07-00	Nut 7/16-14 G5			

NOTE: All component dimensions given in U.S. inches
1 inch = 25.4 mm

**TRACTOR - MODEL NO. YT48XLS (96043015600), PRODUCT NO. 960 43 01-56
MOWER LIFT**

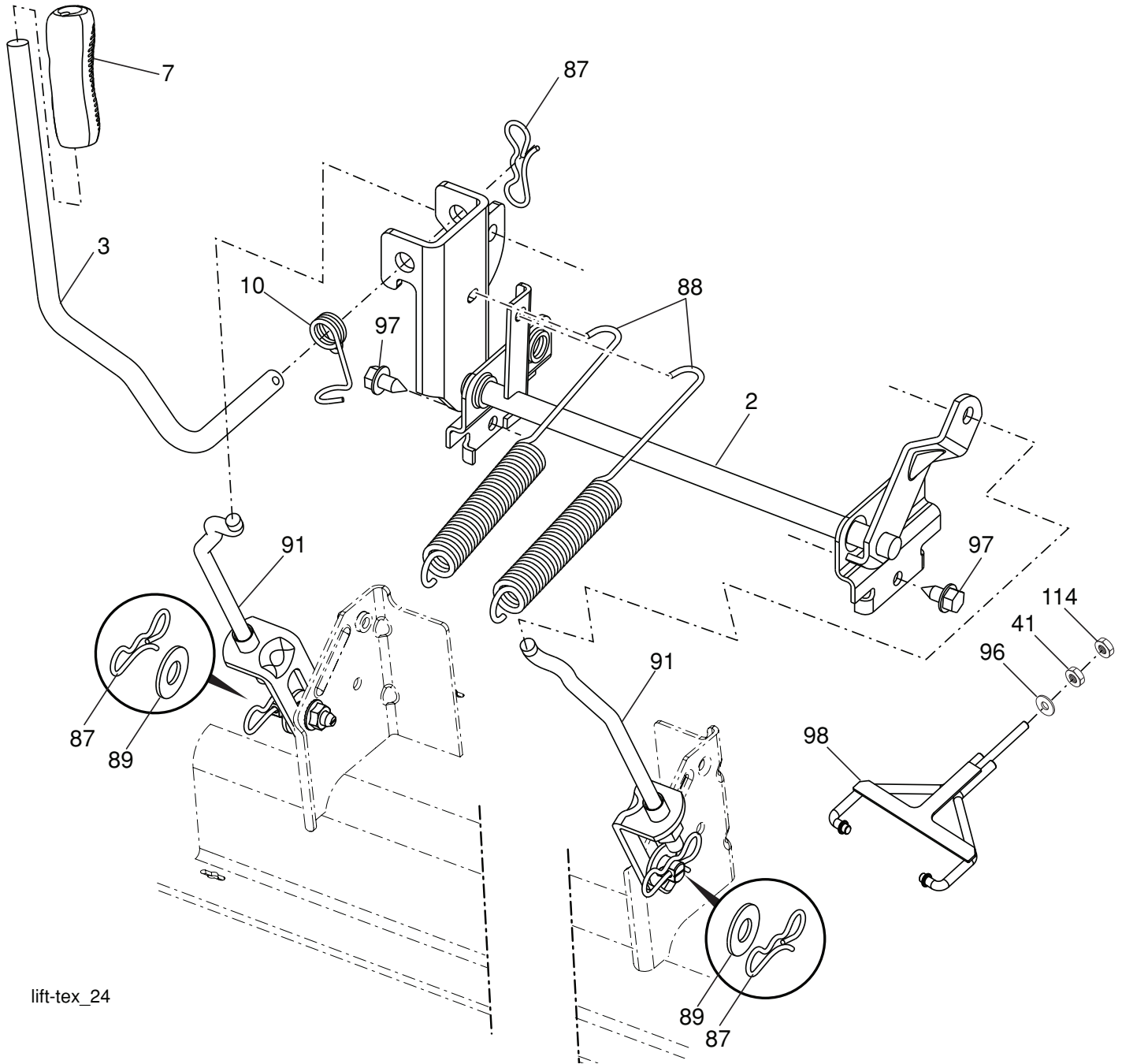

lift-tex_24

KEY NO.	PART NO.	DESCRIPTION
2	532 42 20-27	Shaft Asm., Lift
3	532 19 52-30	Lever Asm., Lift RH
7	580 96 23-01	Grip, Lever
10	532 19 63-14	Spring Torsion
41	532 17 59-94	Nut Lift Link
87	532 19 42-09	Pin Cotter 7/16 Bow Tie Lock
88	532 41 07-10	Spring Lift Assist
89	819 19 19-12	Washer Clear Zinc

KEY NO.	PART NO.	DESCRIPTION
91	532 40 34-07	Link Lift Susp Mower Rear
96	532 19 52-63	Bushing Spherical
97	817 00 06-12	Screw 3/8-16 x 3/4
98	574 82 25-01	Link Asm. Susp. Front Mower
114	873 36 07-00	Nut Jam 7/16-20

NOTE: All component dimensions given in U.S. inches
1 inch = 25.4 mm

**TRACTOR - MODEL NO. YT48XLS (96043015600), PRODUCT NO. 960 43 01-56
SEAT ASSEMBLY**

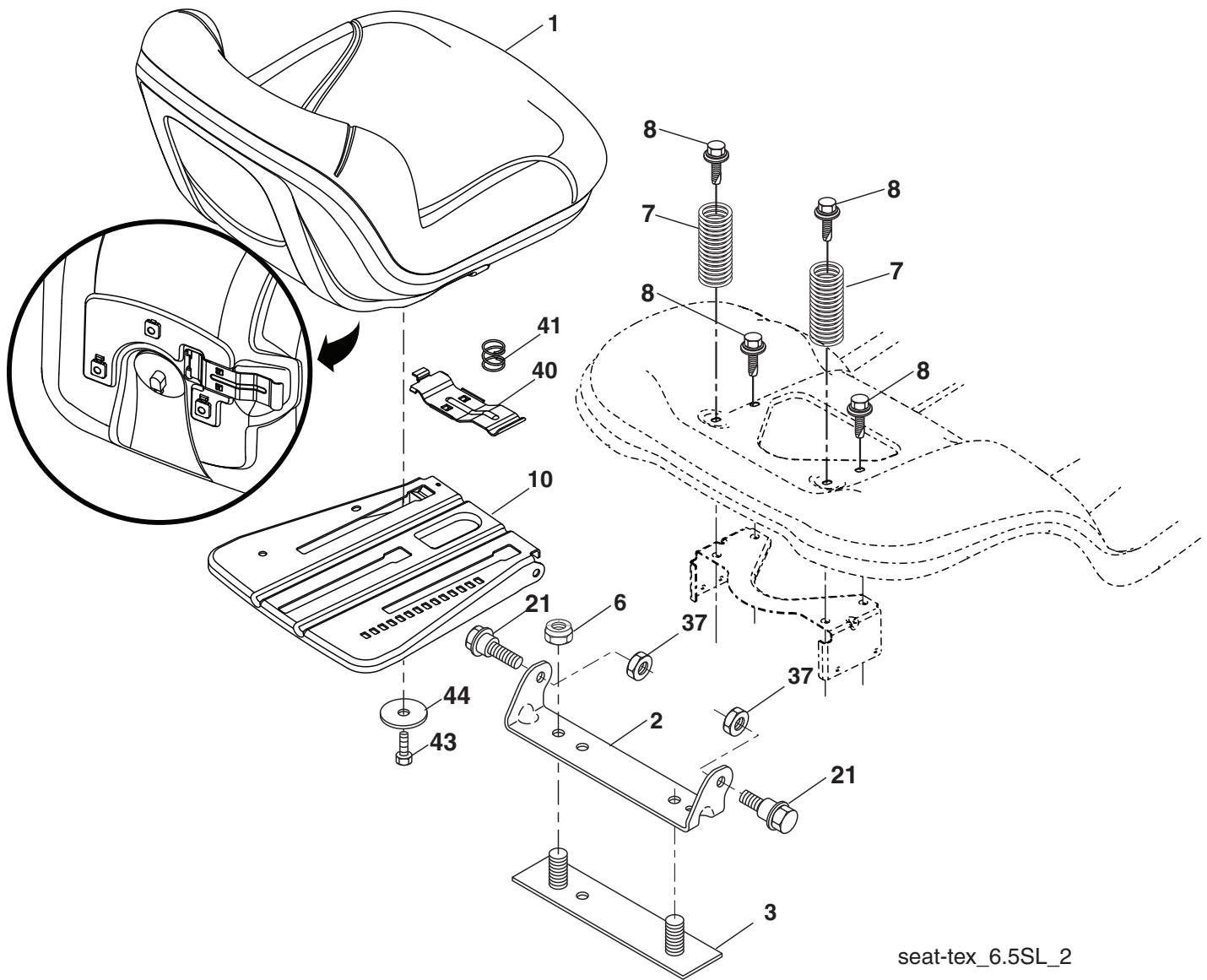

seat-tex_6.5SL_2

KEY NO.	PART NO.	DESCRIPTION
1	532 43 98-22	Seat
2	532 18 01-66	Bracket Pivot Fender
3	532 14 06-75	Strap, Asm Fender
6	873 80 06-00	Nut, Lock W/Ins. 3/8-16 unc
7	532 12 41-81	Spring, Seat Cprsn
8	532 17 18-77	Bolt 5/16-18 unc x 3/4 w/Sems
10	532 19 69-77	Pan, Seat
21	532 17 18-52	Bolt, Shoulder 5/16-18

KEY NO.	PART NO.	DESCRIPTION
37	873 80 05-00	Nut, Lock 5/16-18 unc
40	532 43 98-71	Handle Slide Seat
41	532 19 82-00	Spring Latch Seat
43	874 76 06-12	Bolt Fin Hex 3/8-16 unc x 3/4
44	819 13 38-12	Washer 13/32 x 2-3/8 x 12 Ga.

NOTE: All component dimensions given in U.S. inches
1 inch = 25.4 mm

**TRACTOR - MODEL NO. YT48XLS (96043015600), PRODUCT NO. 960 43 01-56
DECALS**

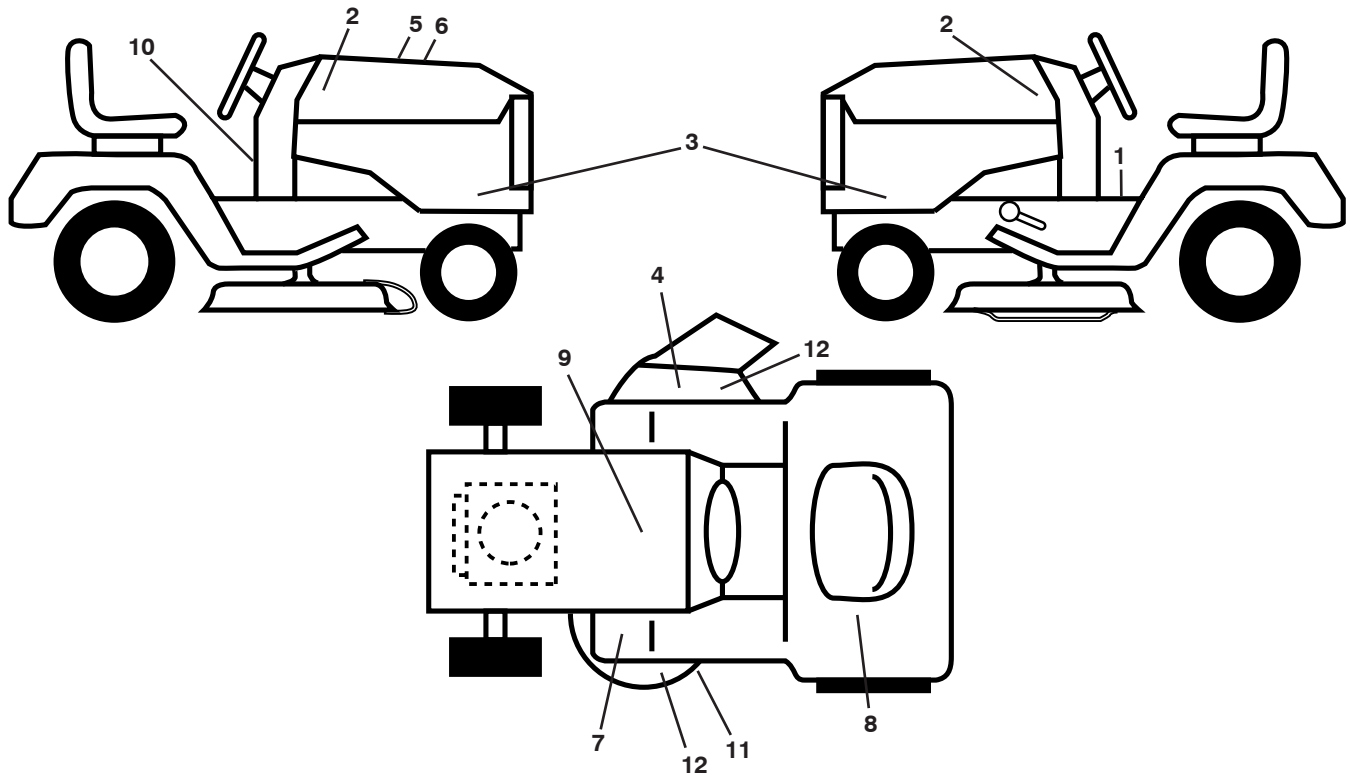

KEY NO.	PART NO.	DESCRIPTION
1	532 41 16-57	Decal, Warning
2	581 62 73-01	Decal, Hood Badge
3	581 54 09-01	Decal, Panel SD
4	539 11 32-24	Decal, Warning
5	532 42 38-29	Decal, Customer Respons.
6	581 48 07-01	Decal, Replacement
7	532 41 86-00	Decal, Pedal Husq. Crown
8	532 42 62-09	Decal, Warning Reserve Fuel
9	532 14 50-05	Decal, Battery Dnge/Poi
10	532 42 41-02	Decal, Warning Spark Arrestor
11	532 19 87-85	Decal, Mower Sch.

KEY NO.	PART NO.	DESCRIPTION
12	581 72 43-01	Decal, No Step
--	532 16 69-60	Decal, Bypass
--	532 43 98-82	Pad, Footrest, LH
--	532 43 98-81	Pad, Footrest, RH
--	539 10 57-46	Decal, Euro
--	539 91 30-10	Decal, Warning
--	581 53 64-26	Manual, Operator's (English/Spanish)
--	581 53 64-27	Manual, Parts (English/Spanish)

WHEELS AND TIRES

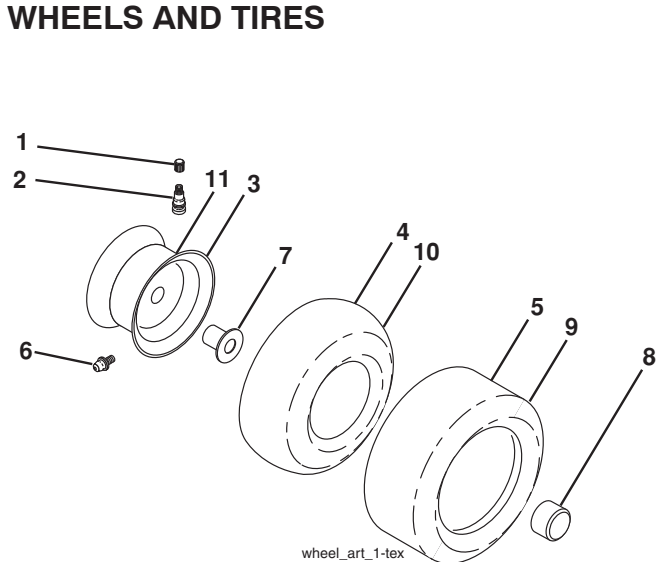

KEY NO.	PART NO.	DESCRIPTION
1	532 05 91-92	Cap Valve Tire
2	532 06 51-39	Stem Valve
3	532 18 18-39	Rim Front Service
4	532 00 81-34	Tube Front (Service Item Only)
5	532 16 10-24	Tire Front
6	532 12 49-57	Fitting Grease (Front Wheel Only)
7	532 12 49-59	Bearing Flange (Front Wheel Only)
8	532 17 50-39	Cap Axle Blk
9	532 17 04-56	Tire Rear
10	532 12 49-26	Tube Rear (Service Item Only)
11	532 13 83-37	Rim Asm 8" rear Service
--	532 14 43-34	Sealant, Tire (10 oz. Tube)

NOTE: All component dimensions given in U.S. inches
1 inch = 25.4 mm

TRACTOR MODELO NO. YT48XLS (96043015600), PRODUCTO NO. 960 43 01-56

DIAGRAMA

SCH12-s

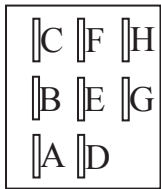
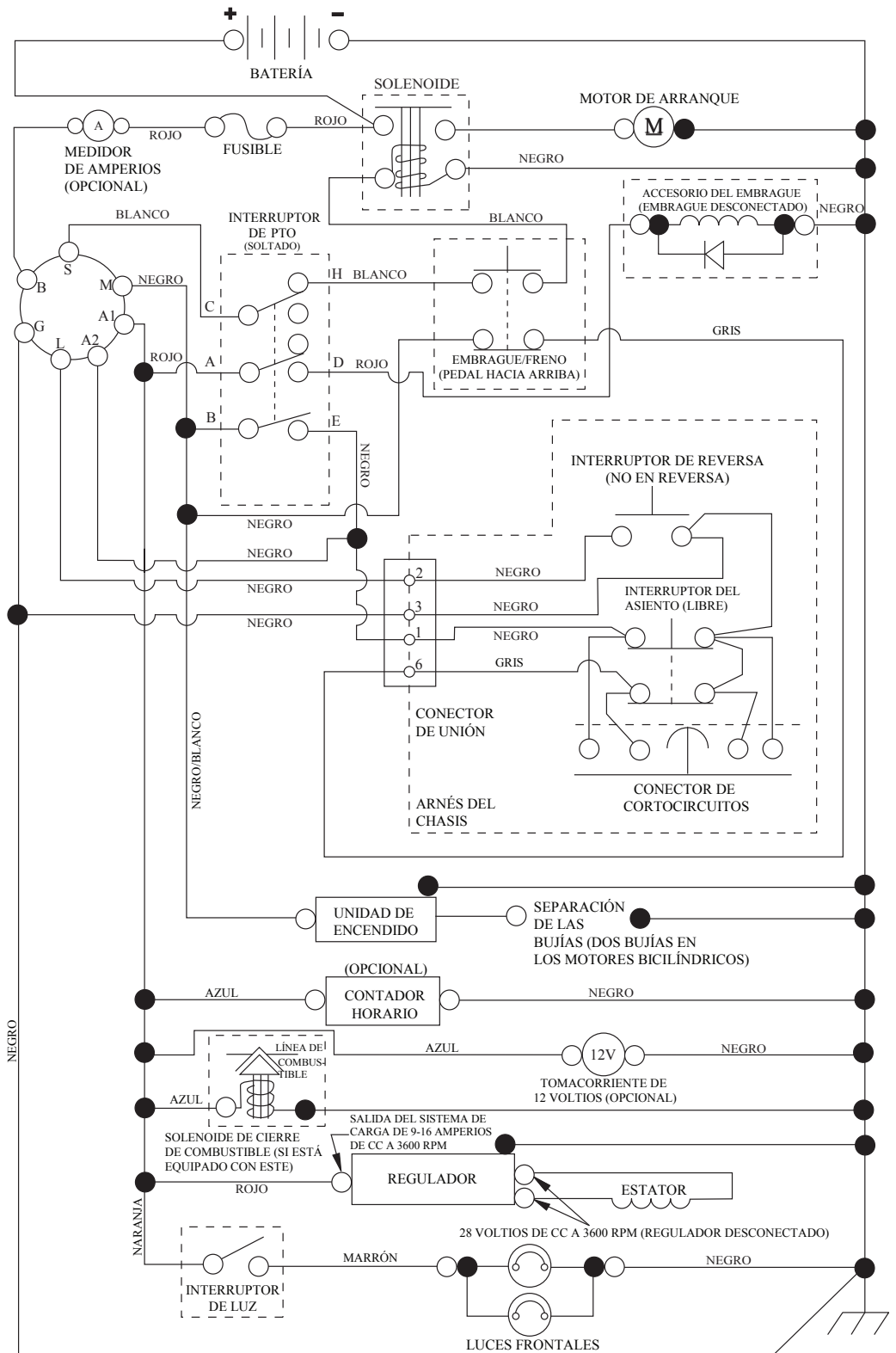

INTERRUPTOR DE PTO (CARA DE ACOPLAMIENTO)

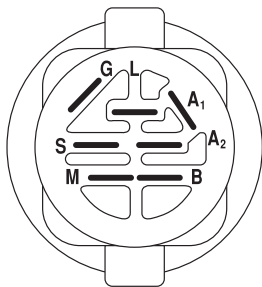

INTERRUPTOR DE ENCENDIDO

POSICIÓN	CIRCUITO «MARCA»
APAGADO	M+G+A1
PONER EN FUNCIONAMIENTO/ANULAR	B+A1
PONER EN FUNCIONAMIENTO	B+A1 L+A2
ARRANCAR	B + S + A1

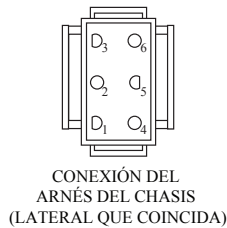

CONEXIÓN DEL ARNÉS DEL CHASIS (LATERAL QUE COINCIDA)



CONEXIÓN PARA EL ARNÉS DEL TABLERO

NOTA SOBRE LAS ABRAZADERAS DE AISLAMIENTO DEL CABLEADO: SI SE QUITAN LAS ABRAZADERAS DE AISLAMIENTO DEL CABLEADO PARA HACER EL MANTENIMIENTO DE LA UNIDAD, SE LAS DEBERÁ INSTALAR NUEVAMENTE PARA PROTEGER EL CABLEADO ADECUADAMENTE.



TRACTOR MODELO NO. YT48XLS (96043015600), PRODUCTO NO. 960 43 01-56

DIAGRAMA ELÉCTRICO

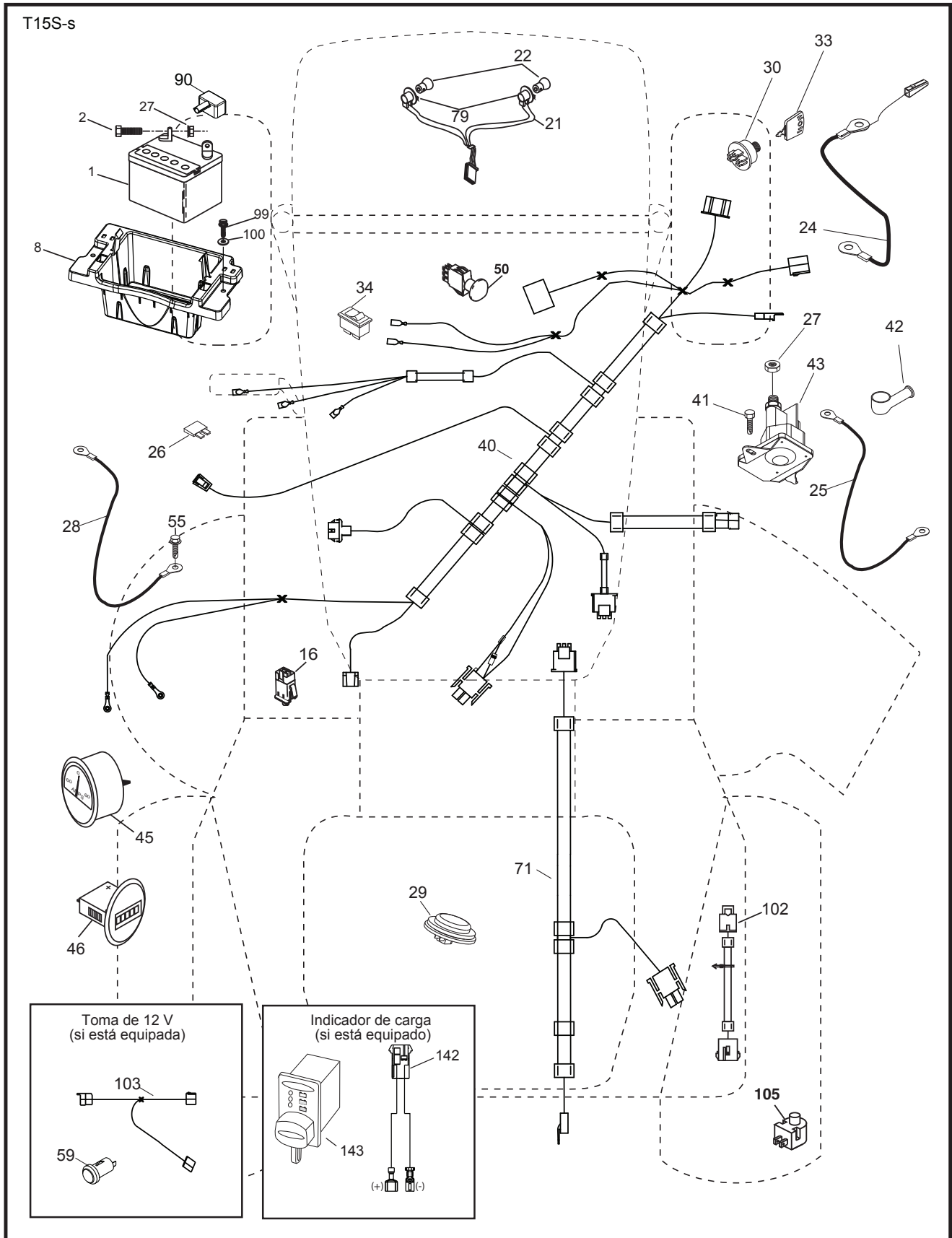

TRACTOR MODELO NO. YT48XLS (96043015600), PRODUCTO NO. 960 43 01-56
DIAGRAMA ELÉCTRICO

CÓDIGO NO.	PIEZA NO.	DESCRIPCIÓN
1	532 16 34-65	Batería
2	874 76 04-12	Perno de cabeza hexagonal de 1/4-20 x 3/4
8	532 41 41-26	Caja de la batería
16	532 17 61-38	Interruptor corta corriente a presión
21	532 40 02-52	Cableado del enchufe para la luz
22	532 00 41-52	Bombilla de luz
24	532 40 02-53	Cable
25	532 41 28-95	Cable
26	532 17 51-58	Fusible
27	873 51 04-00	Tuerca hexagonal Keps de 1/4-20 unc
28	532 14 54-91	Cable a tierra
29	532 40 15-45	Interruptor del asiento
30	532 19 33-50	Interruptor de encendido
33	532 41 19-33	Llave/cadena
34	532 11 07-12	Interruptor de luz/de restauración
40	581 58 35-01	Cableado de encendido
41	817 72 04-08	Tornillo
42	532 13 15-63	Cubierta de la terminal
43	532 19 25-07	Solenoide
45	532 42 52-70	Indicador SRVCMNDR
46	532 42 52-71	Indicador HRMTR
50	532 17 46-51	Interruptor
55	817 06 05-12	Tornillo de 5/16-18 x 3/4
59	532 40 03-03	Enchufe, 12V
71	532 19 42-76	Cableado de encendido, chasis
79	532 17 52-42	Enchufe de cierre por torsión del ensamble de la bombilla
90	532 43 53-95	Tapa de los bornes de la batería
91	532 19 02-70	Correa de la batería
99	817 67 04-12	Tornillo 1/4-20 x 3/4
100	819 09 14-16	Arandela
103	532 42 17-47	Cable 12V
105	532 40 75-68	Interruptor de control del pedal
142	532 44 80-57	Cableado de conector de carga

NOTA: Las dimensiones de todos los componentes están expresadas en pulgadas americanas. 1 pulgada = 25,4 mm

TRACTOR MODELO NO. YT48XLS (96043015600), PRODUCTO NO. 960 43 01-56
CHASIS

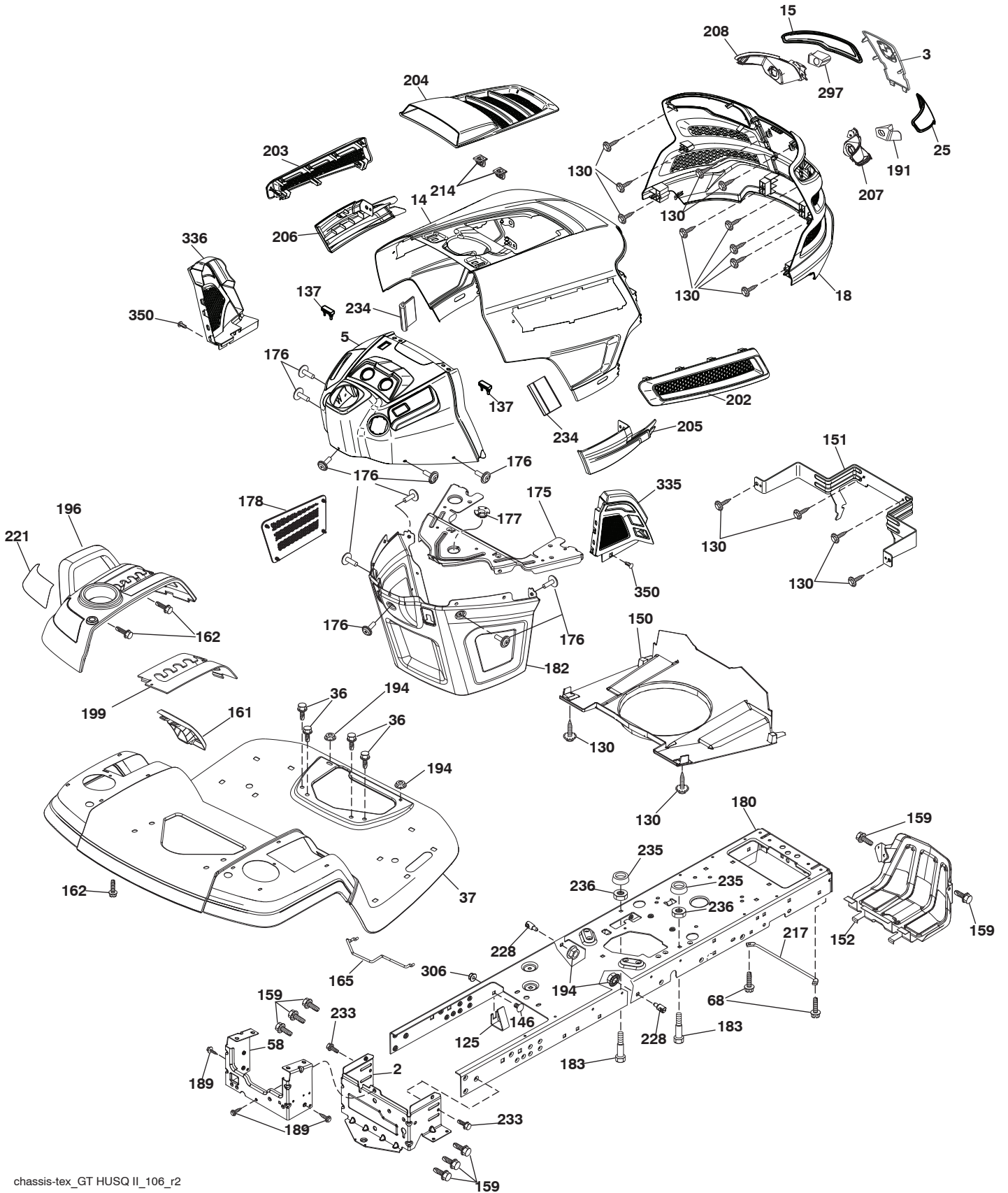

chassis-tex_GT HUSQ II_106_r2

**TRACTOR MODELO NO. YT48XLS (96043015600), PRODUCTO NO. 960 43 01-56
CHASIS**

CÓDIGO NO.	PIEZA NO.	DESCRIPCIÓN	CÓDIGO NO.	PIEZA NO.	DESCRIPCIÓN
2	532 41 22-82	Barra de tracción inferior	191	532 43 74-55	Parte movable reflexivo (LD)
3	532 44 44-81	Aplica Submontaje	194	873 90 05-00	Tuerca de presión de 5/16-18
5	532 43 74-90	Tablero	196	532 43 96-74	Ensamble de la consola de la plata- forma de elevación
14	532 44 11-77	Capota	199	532 19 82-59	Chapa
15	532 43 97-33	Lente izquierdo de la parrilla	202	532 43 97-28	Salida de Ventilación (LD)
18	532 44 06-53	Parrilla	203	532 43 97-27	Salida de Ventilación (LI)
25	532 44 33-85	Lente derecho de la parrilla	204	532 43 57-14	Salida de Ventilación superior
36	817 06 05-12	Tornillo de 5/16-18 x 3/4	205	532 43 97-30	Camisa de Capota (LD)
37	532 44 12-08	Guardabarros	206	532 43 97-29	Camisa de Capota (LI)
58	532 41 22-81	Barra de tracción superior	207	532 43 97-34	Bisel derecho
68	817 49 05-08	Tornillo de 5/16-18 x 1/2	208	532 43 97-35	Bisel izquierdo
125	581 68 48-01	Cierre	214	532 19 91-45	Cierre
130	532 41 63-58	Tornillo No. 10 x 0,75	217	532 40 91-67	Varilla giratoria
137	532 40 75-90	Cubierta Tablero	221	532 19 89-09	Reflector (LI)
146	581 85 79-01	Perno	228	532 19 51-61	Sujetador del travesaño
150	532 43 97-74	Cubierta	233	532 19 65-39	Perno
151	532 43 66-70	Soporte de Capota	234	532 40 47-42	Tope de la capilla
152	532 43 98-70	Protector contra oscurecimiento	235	532 40 61-29	Separador del guardabarros
159	817 00 06-12	Tornillo 3/8-16 x 3/4	236	873 93 05-00	Tuerca de presión 5/16-18 unc
161	532 43 99-29	Ventanilla de combustible	297	532 43 74-56	Parte movable reflexivo (LI)
162	532 14 24-32	Tornillo	306	873 90 06-00	Tuerca
165	532 19 43-30	Soporte de Tanque de Gasolina	335	532 44 82-04	Cubierta (LD)
175	532 19 63-04	Travesaño	336	532 44 53-09	Cubierta (LI)
176	532 40 07-76	Tornillo de 10-24 x 5/8	350	532 44 51-43	Clip del árbol de navidad
177	532 19 52-27	Buje de dirección	--	532 43 18-82	Protector del cepillo
178	532 19 97-82	Red de cargo			
180	532 44 55-59	Chasis			
182	532 40 68-59	Tablero inferior			
183	874 52 05-20	Perno 5/16-18 x 1-1/4			
189	817 00 05-12	Tornillo			

NOTA: Las dimensiones de todos los componentes están expresadas en pulgadas americanas. 1 pulgada = 25,4 mm

TRACTOR MODELO NO. YT48XLS (96043015600), PRODUCTO NO. 960 43 01-56

TRANSMISIÓN

CÓDIGO NO.	PIEZA NO.	DESCRIPCIÓN	CÓDIGO NO.	PIEZA NO.	DESCRIPCIÓN
1	-----	Transeje, TUFFTORQ K46 CR/LD (426121) (Haga el pedido de las piezas al fabricante del transeje.)	187	819 13 32-10	Arandela
2	532 12 35-83	Llave	188	532 19 43-23	Mecanismo de desplazamiento de la varilla de mando del embrague
15	819 13 13-16	Arandela 13/32 x 13/16 x calibre 16	189	532 19 43-17	Palanca acodada del mecanismo de desplazamiento
17	532 41 36-78	Resorte de freno	190	532 19 43-18	Sujetador de la palanca acodada del mecanismo de desplazamiento
26	532 19 96-79	Resorte de travesía	196	817 00 06-16	Tornillo 3/8-16 x 1
29	532 40 38-06	Varilla del freno	197	585 65 86-01	Mecanismo de desplazamiento
33	812 00 00-01	Aro "E"	205	532 12 17-48	Arandela
35	583 86 45-01	Varilla del freno de mano	206	532 19 78-67	Soporte de la travesía
42	532 12 48-72	Cubierta del pedal	207	532 19 78-68	Cierre del control de travesía
49	872 11 06-14	Perno	208	532 19 78-69	Travesía del control del sector
50	532 19 43-27	Polea loca plana	209	532 19 95-92	Travesía del control de Rod
51	873 90 06-00	Tuerca de presión de 3/8-16	210	532 19 78-60	Ensamble del eje de balancín. Control del pedal
52	532 19 43-26	Polea loca con ranura en V con un desplazamiento	211	532 12 01-83	Buje
56	532 13 09-69	Correa trapezoidal de la transmisión	213	532 40 31-19	Travesía del control de la perilla
64	532 19 78-65	Ensamble del eje Control del pedal de freno	214	532 41 68-63	Pedal adelante
70	532 43 96-61	Ensamble de la consola	215	532 40 17-23	Revés del pedal
73	874 49 05-48	Perno 5/16-18 3.75	220	532 19 89-08	Reflector derecho
74	532 14 24-32	Tornillo 1/4 x 1/2	221	532 40 31-87	Abrazadera de retención del resorte de la manija
80	532 44 06-19	Correa de torsión	222	879 21 20-10	Tuerca 21/32 x 1-1/4 x calibre 10
92	874 76 05-20	Tornillo 5/16-18 x 1/2	225	532 40 33-19	Sujetador de la correa
99	532 41 57-42	Varilla de desviación	226	532 40 15-64	Soporte
116	873 90 05-00	Tuerca 5/16-18	227	817 49 05-12	Tornillo 5/16-18 x 3/4
125	817 00 05-12	Tornillo 5/16-18 x 3/4	230	532 18 89-67	Arandela
153	532 12 47-88	Retén del resorte	231	532 40 72-87	Polea loca con ranura V
159	876 02 04-12	Pasador de chaveta de 1/8 x 3/4	284	532 41 76-93	Tuerca U CHNL 1/4-20 550DP .350 PNL
160	532 16 94-84	Abrazadera de retención	307	874 18 04-12	Tornillo 1/4-20 x 3/4
161	532 10 57-09	Resorte de retorno del embrague			
163	532 44 82-75	Control del pedal de la barra			
166	532 42 91-64	Tuerca			
167	532 40 52-57	Pestillo del freno de mano			
170	532 41 34-30	Fijador de la correa			
183	532 13 70-57	Separador			
184	532 44 14 55	Manija del freno de mano			
185	872 11 06-22	Perno 3/8-16 x 2-3/4			
186	532 19 43-21	Espaciador de retención			

NOTA: Las dimensiones de todos los componentes están expresadas en pulgadas americanas. 1 pulgada = 25,4 mm

TRACTOR MODELO NO. YT48XLS (96043015600), PRODUCTO NO. 960 43 01-56
MOTOR

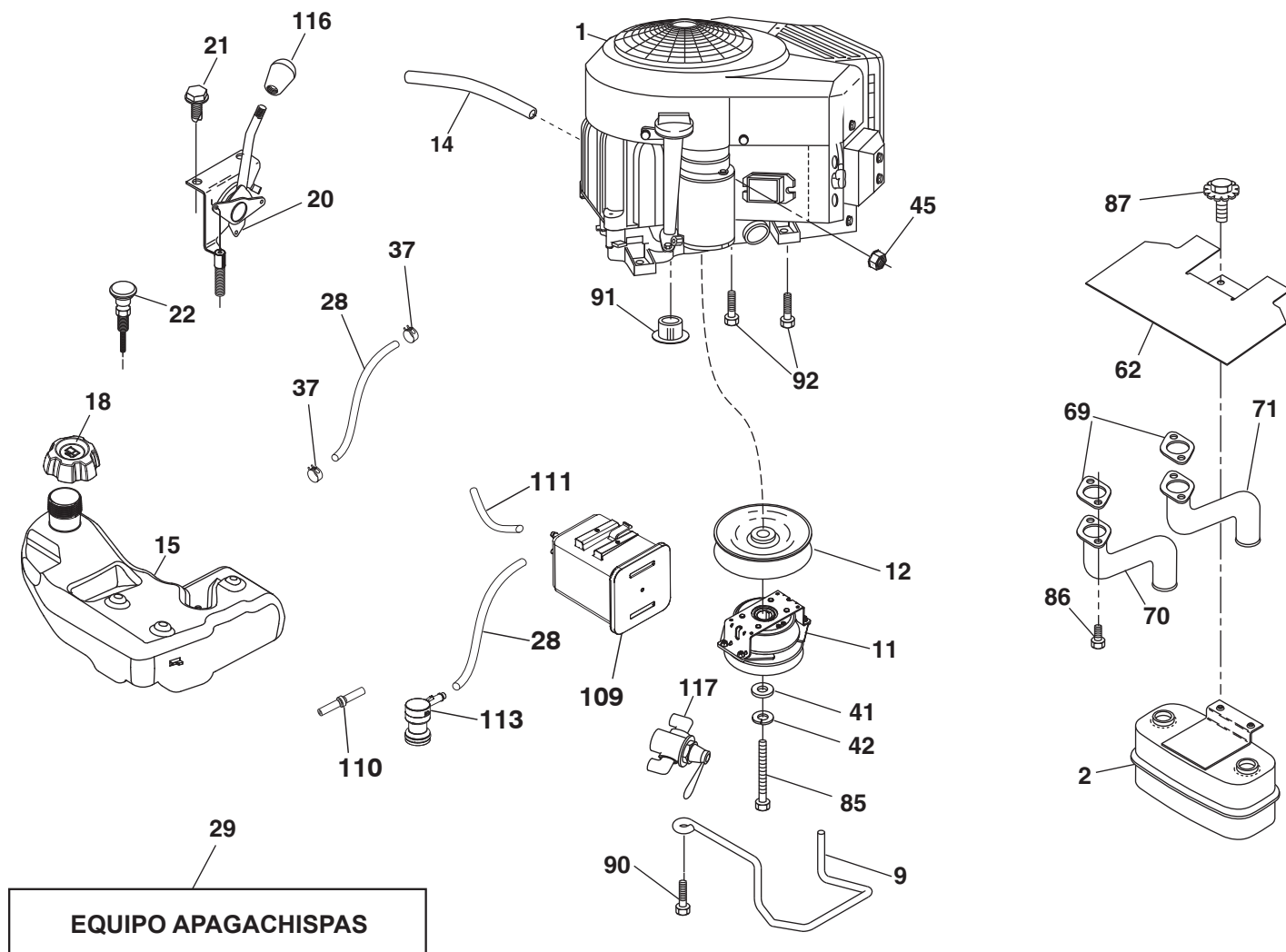

EQUIPO APAGACHISPAS

engine-tex_Kawa-2cyl_41

**TRACTOR MODELO NO. YT48XLS (96043015600), PRODUCTO NO. 960 43 01-56
MOTOR**

CÓDIGO NO.	PIEZA NO.	DESCRIPCIÓN
1	— — — — —	Motor KAWA modelo No. FR730V-AS12 (445364)(Haga el pedido de las piezas al fabricante del motor.)
2	532 44 59-62	Silenciador
9	532 40 86-67	Ensamble del sujetador de la correa del motor
11	587 24 16-01	Embrague de eléctrico
12	532 40 50-97	Polea del motor
14	532 14 84-56	Tubo de fácil drenaje de aceite
15	532 42 07-23	Tanque de Gasolina
18	532 43 92-08	Tapa
20	532 42 43-41	Control del regulador
21	532 41 63-58	Tornillo No. 10 x 0,75 con rosca reforzada
22	532 18 77-67	Control de la estrangulación del motor
28	532 40 11-35	Línea de combustible
29	532 13 71-80	Equipo apagachispas
37	532 12 34-87	Abrazadera de la manguera
41	532 12 61-97	Arandela 1-1/2 x 15/32 x .250
42	810 04 07-00	Arandela de presión de 7/16
45	873 51 04-00	Tuerca
62	532 43 40-17	Silenciador con pantalla térmica
69	532 17 81-51	Junta
70	532 42 47-65	Tubo de escape izquierdo
71	532 42 47-66	Tubo de escape derecho
85	532 17 99-53	Perno de 7/16-20 x 3.75
86	532 18 43-62	Tuerca
87	532 17 18-77	Perno de 5/16-18 unc x 3/4
90	817 00 06-16	Tornillo de 3/8-16 x 1
91	532 18 74-95	Buje
92	817 12 06-16	Tornillo 3/8-16 x 1
109	532 41 41-14	Filtro Le Carbone
110	532 41 41-18	Válvula
111	532 42 07-18	Línea de purge
113	532 41 41-27	Válvula cartucho
116	539 13 26-24	Tacto suave de la perilla
117	532 42 08-28	Válvula de la reserva del combustible

NOTA: Las dimensiones de todos los componentes están expresadas en pulgadas americanas. 1 pulgada = 25,4 mm

Para las piezas del servicio y de recambio del motor, llame el número gratis para su fabricante del motor enumerado abajo:
Kawasaki 1-949-460-5688

TRACTOR MODELO NO. YT48XLS (96043015600), PRODUCTO NO. 960 43 01-56
ENSAMBLE DE LA DIRECCIÓN

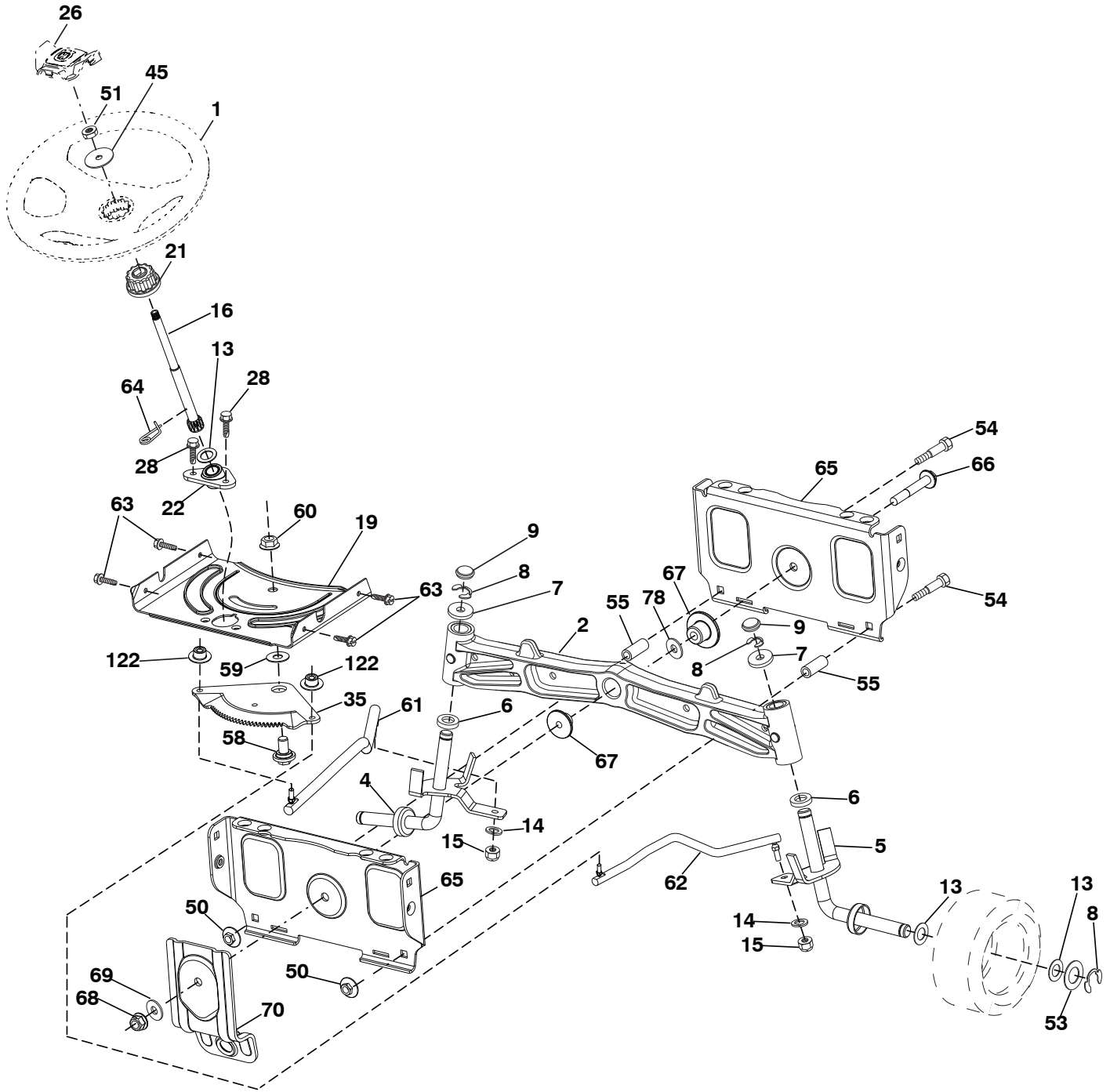

steering-tex_HUSQSR_30

**TRACTOR MODELO NO. YT48XLS (96043015600), PRODUCTO NO. 960 43 01-56
ENSAMBLE DE LA DIRECCIÓN**

CÓDIGO NO.	PIEZA NO.	DESCRIPCIÓN
1	532 43 97-40	Volante de dirección
2	532 19 59-68	Ensamble del eje delantero
4	532 40 30-89	Ensamble del husillo izquierdo
5	532 40 30-90	Ensamble del husillo derecho
6	532 12 49-31	Pista del rodamiento para reforzar el impulso
7	532 12 17-48	Arandela de 25/32 x 1-5/8 calibre 16
8	812 00 00-29	Abrazadera del aro No. T5304-75
9	532 12 12-32	Tapa del husillo
13	532 12 17-49	Arandela de 25/32 x 1-1/4 calibre 16
14	810 04 06-00	Arandela de presión de 3/8
15	873 54 06-00	Tuerca de 3/8-24 unf
16	532 40 82-19	Eje de dirección
19	532 19 47-29	Placa de dirección
21	532 18 67-37	Adaptador del volante de dirección
22	532 42 05-37	Dirección apoyo inferior
26	532 43 97-43	Inserto del volante de dirección
28	817 00 06-12	Tornillo de 3/8-16 x 3/4
35	532 19 47-32	Engranaje del sector de la placa
45	819 18 38-12	Arandela de 9/16 ID x 2-3/8 x calibre 12
50	873 90 06-00	Tuerca 3/8-16 unc
51	873 94 08-00	Contratuerca hexagonal de seguridad de 1/2-20 unf
53	532 18 89-67	Arandela reforzada de, 793 x 1,637 x 0,060
54	874 76 06-36	Tornillo 3/8-16 unc x 2-1/4
55	532 41 47-36	Tornillo 3/8-16 unc x 2-1/4
58	532 19 47-47	Perno de tope del sector del pivote CFM
59	532 19 47-48	Arandela de empuje del sector de dirección
60	873 97 10-00	Tuerca de 5/8-11
61	532 19 47-40	Barra de acoplamiento izquierda
62	532 19 47-41	Barra de acoplamiento derecha
63	817 00 05-12	Tornillo de 5/16-18 x 3/4
64	532 19 98-49	Abrazadera de retención del resorte de la dirección
65	532 19 47-34	Apoyo del árbol delantero
66	871 02 07-48	Perno de cabeza hexagonal con brida acanalada de 7/16-14 x 3
67	532 19 47-37	Buje PM del eje delantero
68	873 90 07-00	Tuerca de 7/16-14 grado 5
69	532 19 91-62	Arandela de 1,5 x 0,505 x 0,118
70	532 19 61-97	Soporte de la plataforma delantera
78	532 05 70-79	Tuerca
122	532 44 49-62	Tapa

NOTA: Las dimensiones de todos los componentes están expresadas en pulgadas americanas. 1 pulgada = 25,4 mm

TRACTOR MODELO NO. YT48XLS (96043015600), PRODUCTO NO. 960 43 01-56
PLATAFORMA DE LA CORTADORA DE CÉSPED

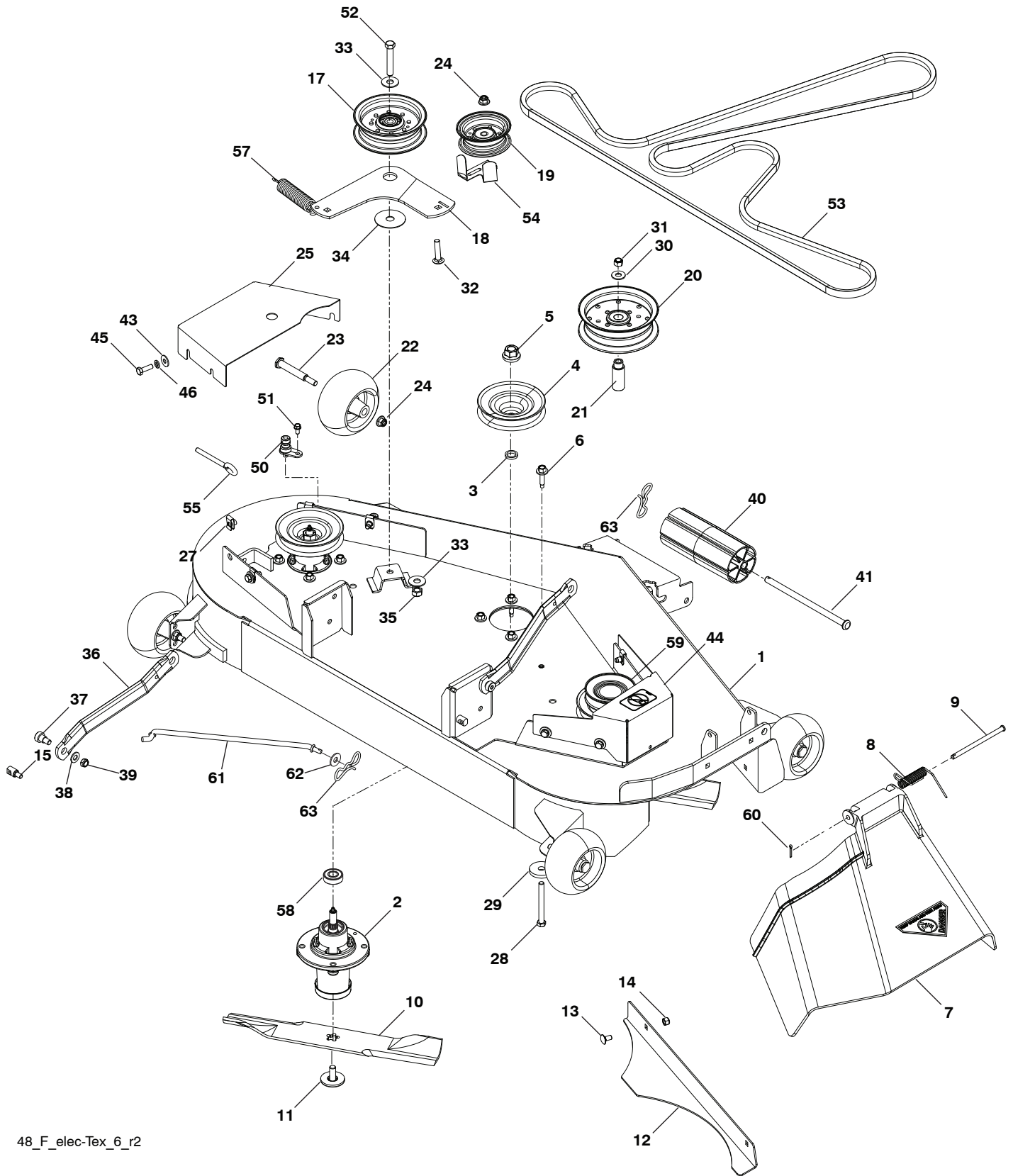

48_F_elec-TEX_6_r2

**TRACTOR MODELO NO. YT48XLS (96043015600), PRODUCTO NO. 960 43 01-56
PLATAFORMA DE LA CORTADORA DE CÉSPED**

CÓDIGO NO.	PIEZA NO.	DESCRIPCIÓN	CÓDIGO NO.	PIEZA NO.	DESCRIPCIÓN
1	594 74 20-01	Carcasa de la cortadora de césped	36	532 19 51-85	Suspensión posterior del brazo
2	539 11 21-70	Ensamble de la cubierta	37	539 11 36-21	Sb 3/8-16 x 3/8 Skt Hd
3	532 18 76-90	Arandela	38	819 13 13-16	Arandela 13/32 x 13/16 x 16
4	532 17 43-75	Polea	39	539 20 02-82	Tuerca 3/8-16
5	539 40 02-34	Tuerca 9/16	40	532 17 60-66	Rodillo de la nariz
6	532 17 39-84	Tornillo	41	532 17 91-27	Rod, rodillo de la nariz
7	539 11 07-33	Canal inclinado de la descarga	43	819 12 14-14	Arandela 3/8 x 7/8 x 14 calibre
8	539 11 07-35	Resorte - torsión	44	575 96 72-02	Protector de la correa LD
9	539 11 07-36	Clavija de horquilla 5/16 x 5.19	45	874 78 05-16	Perno 5/16-18 unc x 1
10	539 11 34-25	Lámina, 16-1/4"	46	810 03 05-00	Arandela 5/16
11	532 19 30-03	Perno, 7/16	50	532 41 55-98	Puerto del derrubio
12	539 11 34-26	Placa del confinamiento	51	817 49 04-08	Perno 1/4-20 x 1/2
13	872 11 05-05	Perno 5/16-18 x 5/8 grado 5	52	874 78 07-40	Hcs 7/16-14 x 2-1/2
14	873 80 05-00	Tuerca 5/16-18	53	574 84 56-02	Correa, cubierta
15	532 19 51-61	Sujetador del perno prisionero	54	532 14 10-43	Protector, correa
17	532 19 61-04	Polea más ociosa	55	539 11 55-74	Perno de argolla 5/16 x 3-1/2
18	574 82 71-01	Brazo más ocioso	57	539 10 68-50	Resorte
19	532 17 79-68	Polea más ociosa	58	532 11 04-85	Rodamiento de bolitas
20	539 13 27-28	Polea más ociosa	59	575 35 29-01	Polea
21	575 22 45-01	Buje más ocioso	60	532 16 94-84	Detenedor del clip
22	532 13 39-57	Rueda, calibrador	61	532 40 48-51	Varilla
23	532 19 34-06	Perno	62	819 13 13-12	Arandela 13/32 x 13/16 x calibre 12
24	521 99 65-01	Tuerca 3/8-16	63	532 19 42-08	Pasador de chaveta de 5/16 con blo- queo en forma de mariposa
25	575 22 47-02	Protector, correa LI	--	532 41 64-05	Accesorio del conexión
27	539 10 47-63	Detenedor 5/16	--	594 74 20-01	Cubierta del cortacéspedes completa
28	539 10 82-71	Hcs 3/8-16 x 3-1/2 grado 5			
29	539 10 65-04	Arandela			
30	819 14 16-14	Arandela 3/8			
31	539 97 69-79	Tuerca 3/8-16			
32	539 99 09-23	Rhsnb 3/8-16 x 1-3/4 grado 5			
33	539 10 48-64	Arandela 7/16 Flat			
34	532 17 85-15	Arandela			
35	873 90 07-00	Tuerca 7/16-14			

NOTA: Las dimensiones de todos los componentes están expresadas en pulgadas americanas. 1 pulgada = 25,4 mm

TRACTOR MODELO NO. YT48XLS (96043015600), PRODUCTO NO. 960 43 01-56
ELEVACIÓN DE LA CORTADORA DE CÉSPED

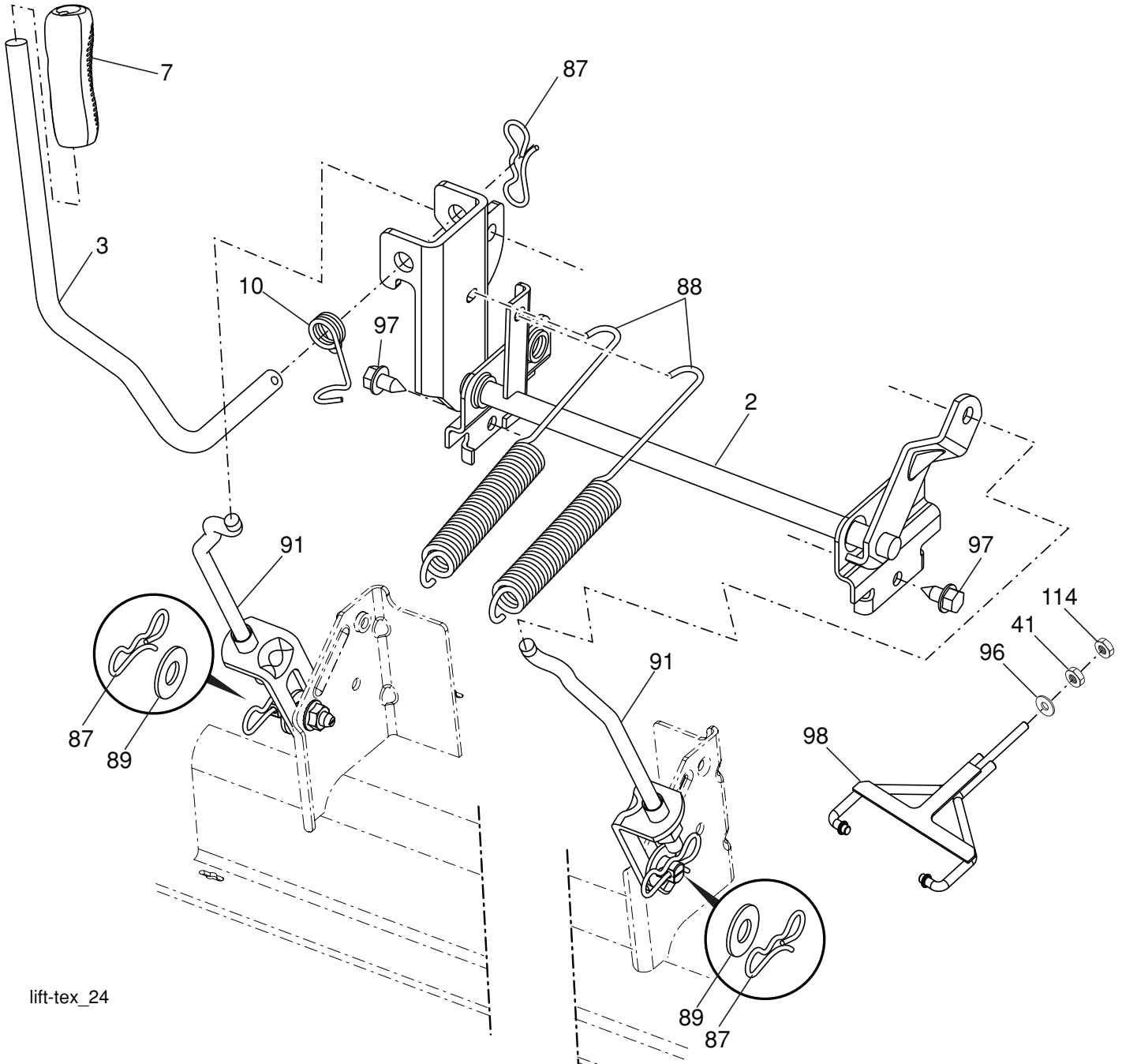

lift-tex_24

CÓDIGO NO.	PIEZA NO.	DESCRIPCIÓN
2	532 42 20-27	Ensamble del eje de la elevación
3	532 19 52-30	Ensamble de la palanca de elevación derecha
7	580 96 23-01	Mango de la palanca
10	532 19 63-14	Resorte de torsión
41	532 17 59-94	Tuerca
87	532 19 42-09	Pasador de chaveta de 7/16 con bloqueo en forma de mariposa
88	532 41 07-10	Resorte de ayuda de la elevación
89	819 19 19-12	Arandela de zinc transparente

CÓDIGO NO.	PIEZA NO.	DESCRIPCIÓN
91	532 40 34-07	Ensamble del acoplamiento Elevación trasera
96	532 19 52-63	Buje
97	817 00 06-12	Tornillo de 3/8-16 x 0,75
98	574 82 25-01	Acoplamiento frontal de la elevación de la cortadora de césped
114	873 36 07-00	Tuerca 7/16-20

NOTA: Las dimensiones de todos los componentes están expresadas en pulgadas americanas. 1 pulgada = 25,4 mm

**TRACTOR MODELO NO. YT48XLS (96043015600), PRODUCTO NO. 960 43 01-56
ENSAMBLE DEL ASIENTO**

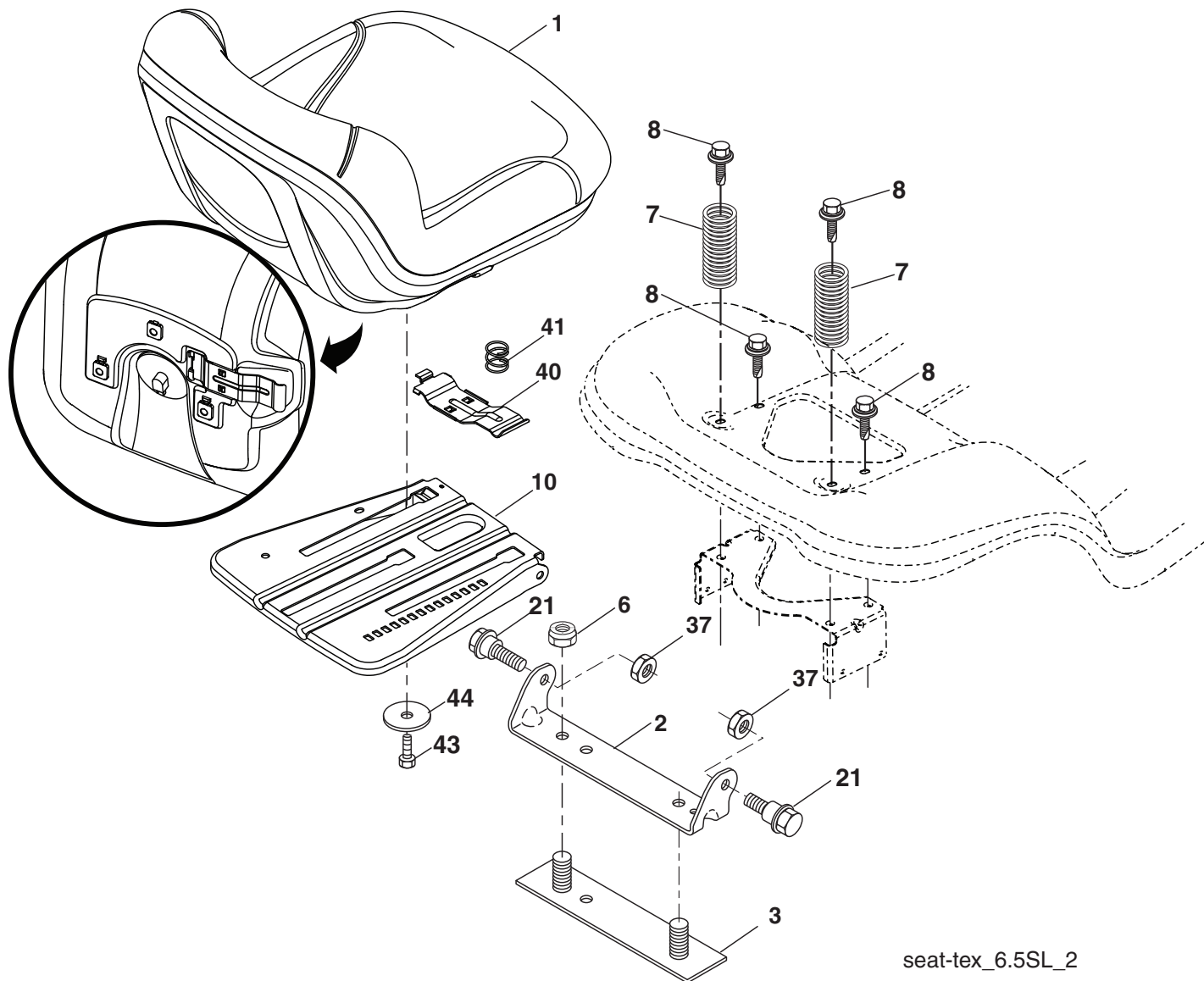

CÓDIGO NO.	PIEZA NO.	DESCRIPCIÓN
1	532 43 98-22	Asiento
2	532 18 01-66	Soporte pivotante del guardabarros
3	532 14 06-75	Conector del ensamble del guardabarros
6	873 80 06-00	Tuerca de presión c/aislamiento de 3/8-16 unc
7	532 12 41-81	Resorte del asiento
8	532 17 18-77	Perno de 5/16" unc x 3/4"
10	532 19 69-77	Bandeja del asiento
21	532 17 18-52	Perno de tope de 5/16-18

CÓDIGO NO.	PIEZA NO.	DESCRIPCIÓN
37	873 80 05-00	Tuerca de presión de 5/16-18 unc
40	532 43 98-71	Manija para deslizar el asiento
41	532 19 82-00	Resorte para trabar el asiento
43	874 76 06-12	Perno de cabeza hexagonal con aleta de 3/8-16 unc x 3/4
44	819 13 38-12	Arandela de 13/32 x 2-3/8 calibre 12

NOTA: Las dimensiones de todos los componentes están expresadas en pulgadas americanas. 1 pulgada = 25,4 mm

TRACTOR MODELO NO. YT48XLS (96043015600), PRODUCTO NO. 960 43 01-56

CALCOMANÍAS

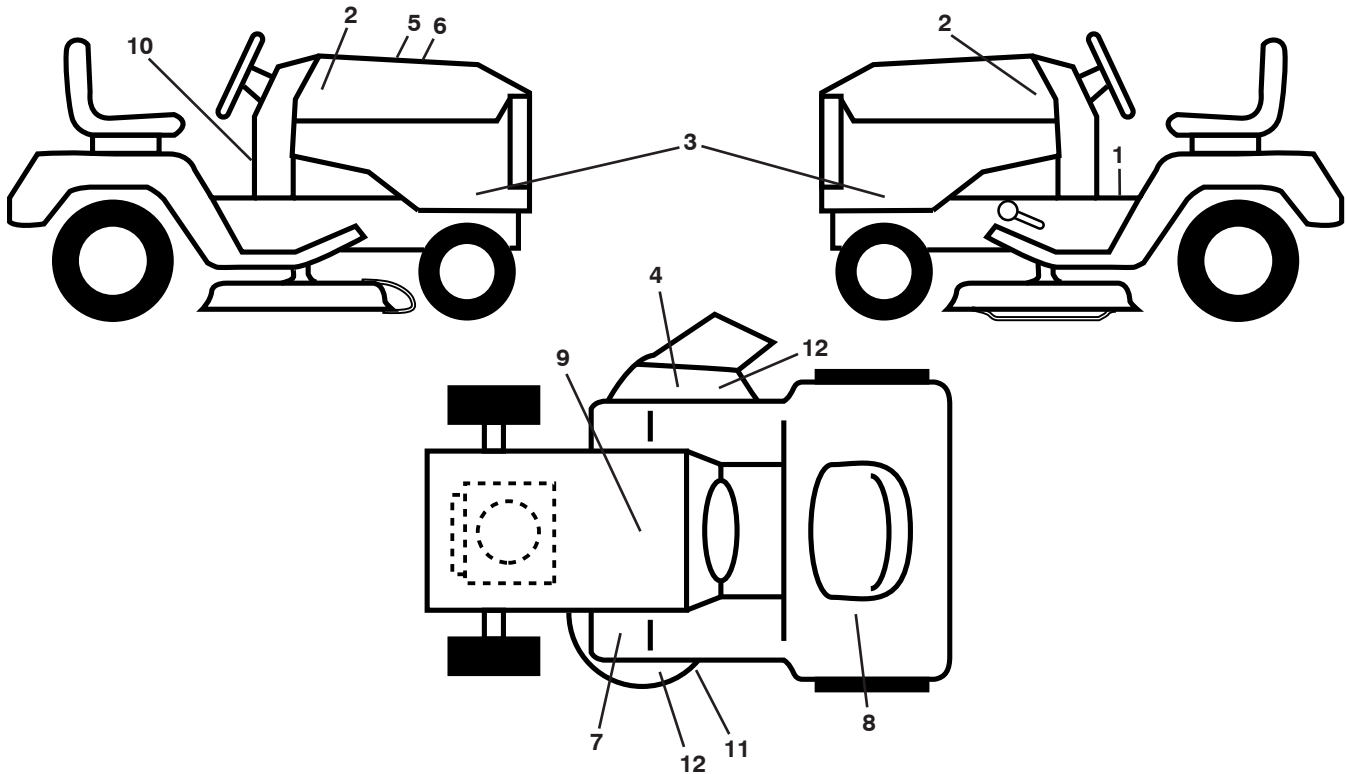

CÓDIGO PIEZA

NO.	NO.	DESCRIPCIÓN
1	532 41 16-57	Calcomanía, Advertencia
2	581 62 73-01	Calcomanía, para la capota
3	581 54 09-01	Calcomanía, panel
4	539 11 32-24	Calcomanía, Advertencia
5	532 42 38-29	Calcomanía del cliente
6	581 48 07-01	Calcomanía de reemplazo
7	532 41 86-00	Calcomanía, Pedal
8	532 42 62-09	Calcomanía, Advertencia de combustible
9	532 14 50-05	Calcomanía, Batería
10	532 42 41-02	Calcomanía, Advertencia apagachispas

CÓDIGO PIEZA

NO.	NO.	DESCRIPCIÓN
11	532 19 87-85	Calcomanía del diagrama de la cortadora de césped
12	581 72 43-01	Calcomanía, no paso
--	532 16 69-60	Calcomanía para la desviación
--	532 43 98-82	Forro del apoyo para los pies izquierdo
--	532 43 98-81	Forro del apoyo para los pies derecho
--	539 10 57-46	Calcomanía, Euro
--	539 91 30-10	Calcomanía, Advertencia
--	581 53 64-26	Manual del operario (Inglês/Espanhol)
--	581 53 64-27	Manual del repuestos (Inglês/Espanhol)

WHEELS AND TIRES

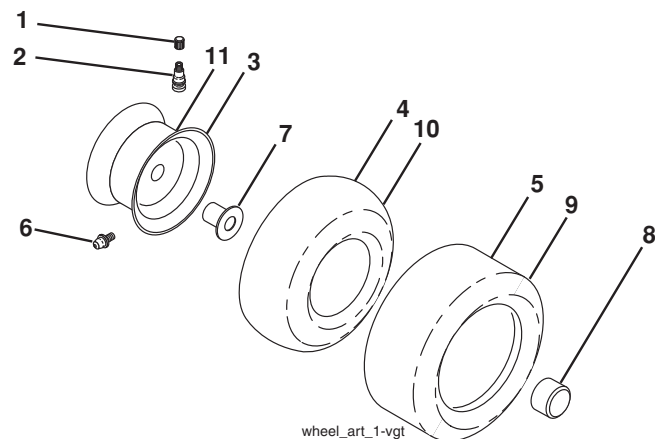

CÓDIGO PIEZA

NO.	NO.	DESCRIPCIÓN
1	532 05 91-92	Tapa de la válvula del neumático
2	532 06 51-39	Vástago de la válvula
3	532 18 18-39	Ensamble de las llantas delanteras
4	532 00 81-34	Cámara delantera
5	532 16 10-24	Neumático delantero
6	532 12 49-57	Accesorio para engrasar (solo para la rueda delantera)
7	532 12 49-59	Rodamiento de la brida (solo para la rueda delantera)
8	532 17 50-39	Tapa del eje
9	532 17 04-53	Neumático trasero
10	532 00 71-54	Cámara trasera (Mantenimiento sólo)
11	532 14 45-10	Ensamble trasero de la llanta
--	532 14 43-34	Sellador para neumáticos (tubo de 10 onzas [283 gr])

NOTA: Las dimensiones de todos los componentes están expresadas en pulgadas americanas. 1 pulgada = 25,4 mm

NOTES/AVISO



www.husqvarna.com